

# A TRIDENT SCHOLAR PROJECT REPORT

NO. 441

---

**A Characterization of the Ship-Effect in a Maritime Environment and Special  
Nuclear Material Detection**

by

Midshipman 1/C Fletcher D. Rydalch, USN

---



**UNITED STATES NAVAL ACADEMY  
ANNAPOLIS, MARYLAND**

This document has been approved for public  
release and sale; its distribution is limited.

**A Characterization of the Ship-Effect in a Maritime Environment and  
Special Nuclear Material Detection**

by

Midshipman 1/C Fletcher D. Rydalch  
United States Naval Academy  
Annapolis, Maryland

---

(signature)

Certification of Advisers' Approval

Assistant Professor Marshall Millett  
Mechanical Engineering  
Department

Professor Martin Nelson  
Mechanical Engineering  
Department

VADM (Ret.) Charles Leidig, USN  
Mechanical Engineering  
Department

---

(signature)

---

(signature)

---

(signature)

---

(date)

---

(date)

---

(date)

Acceptance for the Trident Scholar Committee

Professor Maria J. Schroeder  
Associate Director of Midshipman Research

---

(signature)

---

(date)

# REPORT DOCUMENTATION PAGE

Form Approved  
OMB No. 0704-0188

Public reporting burden for this collection of information is estimated to average 1 hour per response, including the time for reviewing instructions, searching existing data sources, gathering and maintaining the data needed, and completing and reviewing this collection of information. Send comments regarding this burden estimate or any other aspect of this collection of information, including suggestions for reducing this burden to Department of Defense, Washington Headquarters Services, Directorate for Information Operations and Reports (0704-0188), 1215 Jefferson Davis Highway, Suite 1204, Arlington, VA 22202-4302. Respondents should be aware that notwithstanding any other provision of law, no person shall be subject to any penalty for failing to comply with a collection of information if it does not display a currently valid OMB control number. **PLEASE DO NOT RETURN YOUR FORM TO THE ABOVE ADDRESS.**

<b>1. REPORT DATE (DD-MM-YYYY)</b> 05-18-2015		<b>2. REPORT TYPE</b>		<b>3. DATES COVERED (From - To)</b>	
<b>4. TITLE AND SUBTITLE</b> A Characterization of the Ship-Effect in a Maritime Environment and Special Nuclear Material Detection				<b>5a. CONTRACT NUMBER</b>	
				<b>5b. GRANT NUMBER</b>	
				<b>5c. PROGRAM ELEMENT NUMBER</b>	
<b>6. AUTHOR(S)</b> Rydalch, Fletcher Don				<b>5d. PROJECT NUMBER</b>	
				<b>5e. TASK NUMBER</b>	
				<b>5f. WORK UNIT NUMBER</b>	
<b>7. PERFORMING ORGANIZATION NAME(S) AND ADDRESS(ES)</b>				<b>8. PERFORMING ORGANIZATION REPORT NUMBER</b>	
<b>9. SPONSORING / MONITORING AGENCY NAME(S) AND ADDRESS(ES)</b> U.S. Naval Academy Annapolis, MD 21402				<b>10. SPONSOR/MONITOR'S ACRONYM(S)</b>	
				<b>11. SPONSOR/MONITOR'S REPORT NUMBER(S)</b> Trident Scholar Report no. 441 (2015)	
<b>12. DISTRIBUTION / AVAILABILITY STATEMENT</b>  This document has been approved for public release; its distribution is UNLIMITED.					
<b>13. SUPPLEMENTARY NOTES</b>					
<b>14. ABSTRACT</b> Nuclear and radiological materials in the possession of those who intend to use them for malicious purposes are considered to be out of regulatory control. The ability to interdict the movement of special nuclear materials out of regulatory control is of utmost importance in national security. In the maritime environment where such material may be moved on large vessels, detection is complicated. Additionally, the level of the radiation background on and in the immediate vicinity of the ship (where an illicit source might be detected) is affected by the "ship effect." The neutron and radiation ship effect is a phenomenon involving high energy physics where cosmic radiation interacts preferentially with high atomic number materials to produce additional background radiation. This research project's purpose was to advance the ability to identify special nuclear material aboard a maritime vessel by stand-off radiation detection through characterization of the ship effect. The objectives of this project were the completion of the following steps: (1) Integrating a portable and environmentally protected radiation detection system to be used in a mobile situation. (2) Conducting measurements of the background neutron radiation both on land and surrounding a ship on the water. (3) Simulating a radiation signature emitted from nuclear material aboard a ship using radiation transport software. (4) Comparing the measured radiation signatures and modeled source signatures to show the ship effect's impact on detection feasibility of nuclear material in a maritime environment.					
<b>15. SUBJECT TERMS</b> Nuclear detection, ship effect, stand-off radiation detection					
<b>16. SECURITY CLASSIFICATION OF:</b>			<b>17. LIMITATION OF ABSTRACT</b>	<b>18. NUMBER OF PAGES</b>  50	<b>19a. NAME OF RESPONSIBLE PERSON</b>
<b>a. REPORT</b>	<b>b. ABSTRACT</b>	<b>c. THIS PAGE</b>			<b>19b. TELEPHONE NUMBER (include area code)</b>

## **Abstract**

Nuclear and radiological materials in the possession of those who intend to use them for malicious purposes are considered to be out of regulatory control. The ability to interdict the movement of special nuclear materials out of regulatory control is of utmost importance in national security. In the maritime environment where such material may be moved on large vessels, detection is complicated due to the following: the environment, the ship's motion, time constraints, and the large amount of shielding. Additionally, the level of the radiation background on and in the immediate vicinity of the ship (where an illicit source might be detected) is affected by the "ship effect." The neutron and radiation ship effect is a phenomenon involving high energy physics where cosmic radiation interacts preferentially with high atomic number materials to produce additional background radiation. A classic example (for which the effect is named) is that of a ship afloat. This research project's purpose was to advance the ability to identify special nuclear material aboard a maritime vessel by stand-off radiation detection through characterization of the ship effect. Characterizing the radiation ship effect is important because the amount of neutron radiation present may mask special nuclear material. The objectives of this project were the completion of the following steps: (1) Integrating a portable and environmentally protected radiation detection system to be used in a mobile situation. (2) Conducting measurements of the background neutron radiation both on land and surrounding a ship on the water. (3) Simulating a radiation signature emitted from nuclear material aboard a ship using radiation transport software. (4) Comparing the measured radiation signatures and modeled source signatures to show the ship effect's impact on detection feasibility of nuclear material in a maritime environment. Results of the characterization are provided in a contour plot and the impact on detection feasibility for a notional encounter has been determined. It has been found that for a naval vessel, the measurable ship effect extends out approximately 85 meters from the ship while significant impacts reach 50 meters. The background levels along the hull increased up to 50% compared to open water background levels.

## Acknowledgements

The completion of this project would not have been possible without continued efforts and contributions by professors, experts, and supporting organizations. Their contributions have guided me through this process.

Assistant Professor Millett, Professor Nelson, and VADM (Ret.) Leidig, have offered support and expertise at every stop along this research path. They have helped in acquiring resources, giving much needed instruction, and answering many of my countless questions. I am grateful to have worked with such outstanding individuals.

Special thanks are also needed for the support that was given by MAJ Andrew Decker, USA, and the Defense Treat Reduction Agency (DTRA). They have provided funding for my internship at Pacific Northwest National Laboratory and Los Alamos National Laboratory. Their contributions have ignited my desire to help advance radiation detection techniques.

I would also like to individually thank and recognize the material contributions made by SPAWARSCEN-PACIFIC and specifically Mr. Nathan Paradis. The detectors that SPAWAR provided were vital to the success of this project. Mr. Paradis also has taught me how to use these detectors and provided direction throughout the project.

Extra thanks should also be given to the USNA Waterfront Readiness and CDR Raoul J. Bustamante for providing maritime expertise along with maritime equipment. BM2 Blakemore did an outstanding job in driving the boat in nearly all data collection situations.

I express my thanks to Mr. John Welch for securing and providing transportation for the Modular Airborne Neutron Sensor to the Naval Academy.

The following individuals and organizations have also been essential in making this project possible:

CAPT Monte L. Ulmer, Commanding Officer, Naval Support Activity, Washington DC  
LTC Michael Shannon, Director, J9-NSERC, Defense Threat Reduction Agency

## Table of Contents

Abstract.....	II
Acknowledgements .....	III
Table of Contents .....	IV
List of Figures.....	VI
List of Tables .....	VII
List of Symbols and Abbreviations .....	VIII
<b>1 General Overview of Project.....</b>	<b>1</b>
1.1 Background .....	1
1.2 Applicability to the United States Defense .....	2
1.3 Overview of Approach.....	2
<b>2 Background: Radiation and the Ship Effect .....</b>	<b>3</b>
2.1 Special Nuclear Material.....	3
2.2 Maritime Background Radiation.....	3
2.3 Cosmic Radiation and the Radiation Ship Effect.....	3
2.4 Radiation from Special Nuclear Material.....	4
2.5 Ship Effect Determination.....	4
2.6 Statistical Treatment of Data and Accompanying Effect on Detection .....	5
2.7 Currie Criterion and the Application to Statistical Analysis.....	6
<b>3 Approach to Measure and Analyze the Ship Effect.....</b>	<b>8</b>
3.1 Master Schedule .....	8
3.2 Experimental Constraints and Limitations.....	8
3.3 Facilities, Infrastructure, and Devices Used.....	9
3.4 Detectors Used in Data Collection .....	10
<b>4 Data Collecting Process .....</b>	<b>12</b>
4.1 Initial Testing and Detector Validation.....	12
4.2 Experimental Scenarios.....	12
4.3 Challenges to testing process .....	12
<b>5 Measured Results .....</b>	<b>14</b>
5.1 Survey for Sources .....	14
5.2 Location of highest radiation on the USS Barry .....	14
5.3 Radiation vectors out from the USS Barry.....	16
<b>6 Analytical Modeling.....</b>	<b>22</b>
6.1 MCNP Input File.....	22
6.2 SNM Modeled with the Ship Effect.....	23
6.3 Increase in False Positives (False Alarms) from Shifting Mean.....	25
<b>7 Project Outcomes .....</b>	<b>27</b>
7.1 Summary of Measured Results .....	27
7.2 Summary of Detection Feasibility Analysis.....	27
7.3 Future Work .....	27
<b>References.....</b>	<b>29</b>
<b>Appendix A .....</b>	<b>31</b>
<b>Test Plan for the Ship Effect Characterization of the USS Barry at the Washington Navy Yard.....</b>	<b>31</b>
<b>1 Purpose.....</b>	<b>33</b>
1.1 System Description .....	33

<b>2</b>	<b>Operations .....</b>	<b>37</b>
2.1	System Operation .....	37
2.2	Support and Maintenance .....	37
2.3	Go/No Go Criteria .....	37
<b>3</b>	<b>Overall Test Approach .....</b>	<b>38</b>
3.1	Test Schedule .....	38
3.2	Test Design Overview .....	38
<b>4</b>	<b>Data Management .....</b>	<b>43</b>
4.1	Data Logging and Recovery .....	43
<b>5</b>	<b>Other Significant Information .....</b>	<b>45</b>
5.1	Training .....	45
5.2	Logistics and Timeline .....	45
5.3	Test-Day Checklist .....	46
	<b>Bibliography .....</b>	<b>48</b>

## List of Figures

<b>Figure 2-1 USS Barry Moored at the Washington DC Navy Yard in the Anacostia River (image from Google Earth) .....</b>	<b>5</b>
<b>Figure 2-2 A Normal Distribution Curve Percentage of Area.....</b>	<b>5</b>
<b>Figure 3-1 A Schematic of the Radiation Ship Effect Survey System (RSESS).....</b>	<b>10</b>
<b>Figure 4-1 Static locations of actual data collection .....</b>	<b>12</b>
<b>Figure 4-2 Edgewater shown next to the USS Barry collecting data .....</b>	<b>13</b>
<b>Figure 4-3 Static Measurement taken at a specific distance from the USS Barry.....</b>	<b>13</b>
<b>Figure 5-1 Ship effect measured along the hull of the USS Barry.....</b>	<b>15</b>
<b>Figure 5-2 Neutron cps near the hull of the USS Barry (MPS and Modular Systems).....</b>	<b>16</b>
<b>Figure 5-3 Contour plot of ship effect (MPS Systems) .....</b>	<b>17</b>
<b>Figure 5-4 3D plot of ship effect (MPS Systems).....</b>	<b>18</b>
<b>Figure 5-5 Two specific paths used to characterize ship effect.....</b>	<b>19</b>
<b>Figure 5-6 Background neutron radiation detected approaching the ship .....</b>	<b>20</b>
<b>Figure 5-7 Contour plot of ship effect measured by the MANS detector .....</b>	<b>21</b>
<b>Figure 6-1 Visual depiction of the MCNP input .....</b>	<b>23</b>
<b>Figure 6-2 Thresholds for SNM detection with and without the ship effect .....</b>	<b>24</b>
<b>Figure 6-3 Alarm Threshold for SNM Detection Using Smaller Detector .....</b>	<b>25</b>
<b>Figure 6-4 False Alarm Analysis of Ship Effect with MANS detector.....</b>	<b>26</b>
<b>Figure 6-5 False Alarm Analysis with Ship Effect for MPS detectors.....</b>	<b>26</b>
<b>Figure A-1-1 Edgewater Craft.....</b>	<b>35</b>
<b>Figure A-1-2 Edgewater 5 with depicted detectors and connections .....</b>	<b>35</b>
<b>Figure A-3-1 Dynamic motion path and restraints.....</b>	<b>38</b>
<b>Figure A-3-2 Possible data collection route.....</b>	<b>39</b>
<b>Figure A-3-3 Current docking status of the USS Barry .....</b>	<b>39</b>
<b>Figure A-3-4 Current docking of USS Barry with notional dynamic motion path .....</b>	<b>40</b>
<b>Figure A-3-5 Notional path of static collection.....</b>	<b>41</b>



**List of Tables**

<b>Table 2-1 Currie Equation Results.....</b>	<b>7</b>
<b>Table 5-1 Onboard Survey of USS Barry .....</b>	<b>14</b>
<b>Table 5-2 Background measured with associated weather .....</b>	<b>16</b>
<b>Table A-1-1 Specifics for Edgewater Craft .....</b>	<b>35</b>
<b>Table A-1-2 Devices and brief description of role in the testing layout.....</b>	<b>36</b>
<b>Table A-3-1 Overview of test schedule and milestones.....</b>	<b>38</b>
<b>Table A-3-2 Test Objectives and Scenario Correlation.....</b>	<b>42</b>
<b>Table A-5-1 Timeline of move from the Naval Academy to the Washington Navy Yard....</b>	<b>45</b>
<b>Table A-5-2 Planned testing days .....</b>	<b>46</b>
<b>Table A-5-3 Pre-test Checklist.....</b>	<b>47</b>

## List of Symbols and Abbreviations

ITDB	International Atomic Energy Agency's Incident and Trafficking Database
AN/PDR	Army-Navy Portable Radiac designation
CONOPS	Conduct of Operations
DHS	U.S. Department of Homeland Security
DTRA	Defense Threat Reduction Agency (DTRA)
DU	Depleted Uranium
GPS	Global Positioning System
$^3\text{He}$	Helium 3
HDPE	High Density Polyethylene
HPGe	Hyper Pure Germanium
IAEA	International Atomic Energy Agency
INMM	International Nuclear Material Management
ITDB	Incident and Trafficking Database
$^{40}\text{K}$	Potassium-40
MANS	Modular Airborne Neutron Sensor
MCNP	Monte Carlo N-Particle radiation transport software
MPS	Multi-Platform System
NaI	Sodium Iodide
NIST	National Institute of Standards and Technology
NRL	Naval Research Laboratory
RSESS	Radiation Ship Effect Survey System
RSICC	Radiation Safety Information Computational Center
ORTEC	Commercial vendor of radiation detection equipment
SNM	Special Nuclear Material
$^{232}\text{Th}$	Thorium-232
TSD	Technical Services Division, Rickover Hall USNA
$^{238}\text{U}$	Uranium-238
UTM	Universal Transverse Mercator
USCG	US Coast Guard
YP	Yard Patrol Craft

# 1 General Overview of Project

## 1.1 Background

Naturally occurring background neutron radiation around a ship in a maritime environment has not been well characterized in open literature. This background affects the ability to detect nuclear material and must be better understood. The United States must improve its ability to detect nuclear material in the maritime environment because of geographical concerns; 39% of the United States' population lives in counties that make up 95,000 miles of shoreline.<sup>1</sup>

In addition to the maritime vulnerability posed by our long shoreline, the threat from nuclear material is real. The current National Security Strategy<sup>2</sup> states that "Terrorists are determined to buy, build, or steal a nuclear weapon. The threats to our people, our homeland, and our interests have shifted dramatically in the last 20 years. Competition among states endures, but instead of a single nuclear adversary, the United States is now threatened by the potential spread of nuclear weapons to extremists who may not be deterred from using them. Instead of a hostile, expansionist enemy, we now face a diverse array of challenges, from a loose network of violent extremists to states that flout international norms or face internal collapse. The gravest danger to the American people and global security continues to come from weapons of mass destruction, particularly nuclear weapons."

To fulfill this need, different means of interdiction have been considered. Manual inspection is one possibility. Regarding the difficulty of manually inspecting maritime commerce for illicit material, The National Strategy for Maritime Security<sup>3</sup> states that "with as many as 30,000 containers entering the United States every day, physical inspection of all cargo would effectively shut down the entire U.S. economy, with ripple effects far beyond the seaports. Inspections on this scale are prohibitively expensive and often ineffective."

The need to detect nuclear materials is also shown by interdiction experience. The International Atomic Energy Agency's Incident and Trafficking Database (ITDB)<sup>4</sup> is an "information system on incidents of illicit trafficking and other unauthorized activities and events involving nuclear and other radioactive material outside of regulatory control." The 2013 report states that "during 2012, 160 incidents were confirmed to the ITDB. Of these, 17 involved possession and related criminal activities, 24 involved theft or loss and 119 involved other unauthorized activities."<sup>4</sup>

Information reported to the ITDB demonstrates that:

- The availability of unsecured nuclear and other radioactive material persists
- Effective border control measures help to detect illicit trafficking, although effective control is not uniformly implemented at all international border points
- Individuals and groups are prepared to engage in trafficking this material.

These findings indicate that there is both interest and activity in the illicit transport of Special Nuclear Material (SNM). Efforts are underway to improve our ability to prevent illicit trafficking of nuclear material. Over the last several years, studies of both the shipboard radiation (i.e. ship effect)<sup>5,6</sup> and studies of maritime detection systems<sup>7,8</sup> have been conducted. The United States Naval Academy has been involved in some of these studies. Past Trident<sup>9</sup> and other USNA research efforts<sup>10</sup> have been involved in quantifying the ship effect. Although extensive research has been conducted on the effects of naturally occurring background neutron radiation, a search of open literature has not shown any evidence of studies that spatially characterize the ship effect

near a vessel where standoff detection would be conducted, nor studies that consider both the ship effect and the signature from radiological sources onboard a ship in a standoff detection scenario. This current study contributes to our ability to interdict SNM in a maritime environment in two ways: (1) by characterizing the background neutron radiation in the vicinity of a waterborne vessel where standoff detection would be conducted and (2) by combining the effects of this measured neutron background with a simulated source signature from an onboard SNM source using radiation transport software in order to quantify the impact of the ship effect on standoff detection.

## **1.2 Applicability to the United States Defense**

To defend the United States from potential nuclear threats, effective detection systems and effective operational protocols must be developed. Regarding the interception of illicit cargo, this development must include an analytically based understanding of our ability to exploit radiation signature from SNM in the maritime domain. The essence of the question that is being considered in this research is how the detection of radiation emitted from special nuclear material on a monitored ship is affected by the increased radiation background caused by the ship effect. The determination of the ship effect will allow the United States to continue to advance its security measures against possible nuclear threats.

## **1.3 Overview of Approach**

The radiation ship effect is a radiation phenomenon surrounding a large mass of higher atomic number material, compared to surroundings. This condition is met with a large vessel on the water which is considered to be a concentrated amount of iron (generally) surrounded by the lower atomic number materials hydrogen and oxygen. This phenomenon is understood and has been explained in published reports, including a report by three scientists from the Naval Research Lab (NRL)<sup>11</sup> where the authors highlight the fact that the ship effect is observable around all massive objects. Furthermore, the authors have quantified the additional (cosmic-ray sourced) background neutron signature from general massive objects such as buildings and structures at about 20 neutrons per kg of material per second. The additional contribution offered by this current Trident research project is that the phenomenon is spatially measured and characterized on the water, in the immediate vicinity of the suspect ship where standoff detection activities are anticipated whereas prior research has focused on measuring the ship effect's magnitude onboard the vessel<sup>12</sup> the associated neutron energy spectrum<sup>13</sup>, and the dependence on material.<sup>5, 11</sup>

In order to conduct waterborne measurements, the research plan included integrating multiple detection systems. Components and equipment were all brought to USNA; the systems were proven functional on land and were then integrated onto a small 26 foot long open hull boat (provided by the USNA Waterfront Division) that was capable of conducting radiation surveys near ships. The integration accounted for environmental and operational requirements and constraints. The integrated system comprised three different detectors. Data were collected in the Anacostia River from 5 to 25 November, 2014. Based on collected data, a characterization of the ship effect was produced. This characterization was then compared to a modeled notional nuclear source to determine impact on detection feasibility.

## **2 Background: Radiation and the Ship Effect**

### **2.1 Special Nuclear Material**

The reason for characterizing the ship effect is to assist in the advancement of our ability to detect special nuclear materials. SNM are those materials that are the primary ingredients of nuclear weapons. They are defined by Title I of the Atomic Energy Act of 1954<sup>14</sup> as plutonium, uranium-233, or uranium enriched in the isotopes of uranium-233 or uranium-235. The importance of protecting this material has been recognized since nuclear weapons were conceived. The Atomic Energy Act states:

Source and special nuclear material, production facilities, and utilization facilities are affected with the public interest, and regulation by the United States of the production and utilization of atomic energy and of the facilities used in connection therewith is necessary in the national interest to assure the common defense and security and to protect the health and safety of the public.<sup>14</sup>

### **2.2 Maritime Background Radiation**

Ionizing radiation is the propagation of energy and particles from matter and is present everywhere on earth. It nominally comes from four sources: (1) the radioactive decay of primordial (naturally occurring) radioactive isotopes, (2) cosmic radiation from outside our atmosphere, (3) cosmogenic radiation from the decay of isotopes created by cosmic radiation, and (4) radiation from the decay of man-made radioactive isotopes, whether related to weapons, nuclear power, or industrial/medical sources. Each of these four contributors has different magnitudes based on location and altitude. The first two sources are the major contributors in the maritime environment<sup>11</sup>. Background radiation consists primarily of alpha and beta particles, gamma rays and X-rays, and neutrons. Alpha and beta particles have a short range (cm or less) which makes them of little or no utility in the detection of SNM in a maritime environment. Gamma rays and neutrons have longer range<sup>15</sup> and thus have utility for SNM detection. The detection systems used in this project collected both neutron and gamma signatures, though only the neutron signatures were analyzed. The contribution from cosmic radiation is related to the Earth's magnetic field (and so latitude and longitude), altitude above the surface, and the fluence and energy of arriving particles. In general, the potential for cosmic background does not change significantly between land and sea; it is a function of the atmosphere.<sup>11</sup> Neutron radiation background is primarily created by cosmic radiation, and experience has shown that some decrease in neutron background may be evident in the move from land to water.<sup>16</sup> This result is expected because cosmic radiation preferentially interacts with high atomic number materials. High atomic number materials are more often on land and lower atomic number materials make up the sea. This difference follows the ship effect, where background is higher near a ship than on open water.

### **2.3 Cosmic Radiation and the Radiation Ship Effect**

The term cosmic ray describes high energy charged particles that enter the Earth's atmosphere at near the speed of light.<sup>17</sup> These particles may come from events such as supernova explosions, though there are also cosmic rays that come from our sun and from within our solar system. Approximately 90% of galactic cosmic rays are protons. As these particles enter the atmosphere, they collide with nuclei, resulting in spallation, or the ejection of nuclear particles from the target nuclei. The ejected secondary particles include neutrons, protons, and muons as well as other

particles<sup>5</sup>. These secondary particles, in turn, cause additional spallation through collisions, and a particle shower results that continues to the Earth's surface. At the surface, the secondary particles are primarily neutrons and muons, with the neutrons causing a majority of the spallation events<sup>5</sup> that impact detection. At high neutron energies (> 10 MeV), neutron interaction probabilities are related to the atomic number. For example, the total neutron cross section (or reaction probability) at 10 MeV consistently decreases with atomic weight from lead to iron to calcium to silicon to carbon to hydrogen, following the atomic weight from high to low. Due to the nature of neutron interaction probabilities, a higher level of neutron spallation is expected from higher atomic number materials. This has been shown to be the case.<sup>5</sup> When an object of higher atomic number materials is isolated in an environment of lower atomic number materials, the effect of the increased neutron spallation near the massive object is called the ship effect, so called because, anecdotally, this phenomenon was first discovered when U.S. detectors were used to search for nuclear materials on adversary ships during the cold war.<sup>5</sup>

## 2.4 Radiation from Special Nuclear Material

The production of nuclear weapons requires SNM, and all of these materials are radioactive. This limits the materials being sought through surveys, and limits the signatures of interest. For example, the signatures of <sup>235</sup>U and <sup>239</sup>Pu are of interest, whereas the signatures of naturally occurring thorium and potassium are likely not. The signature of <sup>235</sup>U is a lower energy gamma signature while the signature of <sup>239</sup>Pu is a mixed gamma and neutron signature. Beyond fissile materials, other associated materials may also emit a detectable signature, including natural or depleted uranium. Natural uranium contains only 0.7% of fissile <sup>235</sup>U. To support a fission chain reaction in a weapon, uranium is required to be enriched to above 85-90% in <sup>235</sup>U. Depleted Uranium (DU) results after uranium is processed through an enrichment facility. DU contains 99.7% <sup>238</sup>U and by itself is not fissile, though it may be used to maximize the effectiveness of a nuclear weapon by reflecting and containing the energy during the process of a detonation. It may also be used as a shielding material. Due to both the availability of natural or depleted uranium, as well as the association with nuclear weapons, <sup>238</sup>U also provides a signature of interest to interdiction. The signature from <sup>238</sup>U consists of higher energy gammas from its decay products.

## 2.5 Ship Effect Determination

The spatial characterization of the ship effect was determined by measuring radiation background at different locations. As neutron background is generally low compared to gamma background, statistically accurate neutron data required large sensors and long collection times. Data were required to be collected in both dynamic and static measurements. The instrumentation suite included the ability to provide a GPS location tag to all collected data, and the test plan (see Appendix A) was prepared to ensure that the two dimensional space adjacent to the ship was uniformly and thoroughly surveyed in order to develop a two dimensional map of radiation signature that covers the entire space anticipated for standoff radiation surveys. Static measurements provided higher accuracy of background neutron counts, while dynamic measurements provided better coverage of the survey area for gamma signatures.

As shown in Figure 2-1, the USS Barry is moored to a pier on its port side, and adjacent to another pier on its starboard side. The USS Barry is a Forrest Sherman class destroyer, displacing 4000 tons. The ship was decommissioned in 1982 and is used as a museum ship at the Washington Navy Yard. The surveying was conducted on the starboard side of the Barry in a

zone that includes the adjacent pier. The ship effect from the pier was anticipated to be lower than the effect from the ship due to the ship's higher mass and higher atomic weight (iron versus other lower Z asphalt and wood materials). Separate measurements of the pier were conducted with no observable effect on neutron background.



**Figure 2-1 USS Barry Moored at the Washington DC Navy Yard in the Anacostia River (image from Google Earth)**

## 2.6 Statistical Treatment of Data and Accompanying Effect on Detection

The occurrence of radiation in the environment is generally a statistical process. Fortunately, for detection feasibility, radiation from radioactive material follows a Poisson process. One characteristic of the Poisson distribution is that the variance is equal to the mean value, or the standard deviation is simply the square root of the mean value<sup>18</sup>. In other words, if the mean value for the number of radiation events counted by a detector during a certain time period may be determined, then the standard deviation about this mean value is expected to be the square root of the number. Figure 2-2 is a graph of a probability density function for the normal distribution<sup>19</sup> and illustrates the allocation of data by percentages.

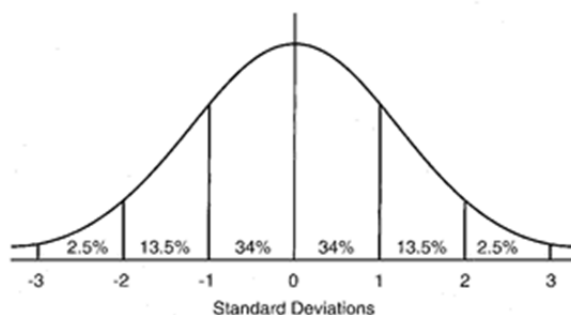

**Figure 2-2 A Normal Distribution Curve Percentage of Area**

Figure 2-2 shows the allocated percentages for each area under the curve after each standard deviation away from the mean. This plot shows that within two standard deviations from the

mean, 95% of the events are expected to occur, while 5% of the events will occur outside of two standard deviations.

Consider the following two cases for examples of how this applies: If the detector's average response during a particular timed counting period is found to be 100 counts, then the standard deviation is expected to be 10 counts, or 10% of the mean value. If the detector's average response during the same timed trial is 10,000 counts, then the standard deviation of this response is expected to be 100 counts, or 1% of the mean value. In either case, the uncertainty associated with a single count is expressed in terms of one standard deviation, so the first count value would be expressed as  $100 \pm 10\%$  and the second as  $10,000 \pm 1\%$ .

Since the measured background radiation level is continually statistically fluctuating (or exhibiting a Poisson distribution), detecting the signature emanating from a particular source within this background requires that the detected signature stand out – or be large relative to the expected standard deviation of the background. Given this condition, two observations can be made from the two examples above. First, in a single counting period, the higher the mean value of the background, the higher the standard deviation, so in order to be distinguishable, the contribution from a specific source must be higher – or the ability to distinguish a source is inversely related to the background level. Second, with a higher mean value, the magnitude of the standard deviation relative to the mean becomes smaller – or by counting for a longer period (and thus raising the mean value), the expected relative fluctuation becomes smaller. The implication of this second observation is that if the mean background level is known to a high degree of accuracy, then by continuing a survey for a long enough periods, the additional contribution from a radiation source will eventually stand out above the expected statistical fluctuation and be distinguishable. Both of these observations lead to the same requirement: in order to maximize the effectiveness of a radiation survey intended to sense the presence of illicit nuclear material, the background radiation levels must be well understood.

## 2.7 Currie Criterion and the Application to Statistical Analysis<sup>20</sup>

Investigation into determining the required instrument response for positive identification with background present lead to finding and applying the Currie Criterion. In this research, the Currie Criterion<sup>18</sup> was used to determine the required source signature strength for detection within a given background and with a given confidence. A derivation of the equation was given by Langan in his report regarding the Currie Criterion.<sup>20</sup> Although the Currie Criterion is not built specifically around a Poisson distribution, at high success levels, a Poisson distribution can be described by a Gaussian distribution,<sup>21</sup> and therefore the Currie equations apply. Because neutron radiation background follows a Poisson distribution, the Currie Criterion applies and a derived relationship may be applied to determine necessary source levels needed for source detection. The Currie equation is found in equation (1),

$$N_D = 2t\sqrt{(2\sigma_{N_B})} + t^2. \quad (1)$$

Where:

$N_D$  = number of counts needed from a source to ensure a false positive and false negative rate with a given %,

$\sigma_{N_B}$  = standard deviation of the background counts,  $\sigma_{N_B} = \sqrt{(N_b)}$ ,

$N_B$  = number of background counts in counting time, and

$t$  = standard deviation from the mean.



The Currie Criterion has different coefficients depending on the level of confidence that is desired, where the level of confidence is one minus the uncertainty. The equations are shown in Table 2-1. As the desired confidence level increases, the required source counts also increases.

**Table 2-1 Currie Equation Results**

Uncertainty	Currie Equation: $N_D = 2t\sqrt{2}\sigma_{N_B} + t^2$
10%	$N_D = 4.653\sigma_{N_B} + 2.706$
5%	$N_D = 5.544\sigma_{N_B} + 3.842$
1%	$N_D = 7.298\sigma_{N_B} + 6.656$
0.3%	$N_D = 8.480\sigma_{N_B} + 9$

Though operational limits may be set far below this value, this analysis assumed a 95% confidence level, or 5% probability of a false positive as an acceptability threshold. The equation used to determine the minimum number of counts needed from the source to ensure a false positive rate no larger than this desired 5%, when the system is operated, is found in equation (2),

$$N_D = 5.544\sigma_{N_B} + 3.842. \quad (2)$$

In the analysis conducted for this research, the Currie Criterion system response levels were determined using equation (2) to provide alarm thresholds used in determining detection feasibility.

### 3 Approach to Measure and Analyze the Ship Effect

#### 3.1 Master Schedule

The project was started in October 2013 and lasted 18 months. An overview of the timeline of events that lead to the completion of the project was as follows:

- Acquired large and sensitive detectors through collaboration with SPAWAR, PNNL, and USNA (June 1, 2014 – September 30, 2014)
- Evaluated and tested the detectors that were used in data collection (August 1, 2014 – October 30, 2014)
- Combined data acquisition and system proof testing through data collection around the Naval Academy Yard. (August 1, 2014-September 16, 2014)
- Determined how best to integrate the detection systems (September 7, 2014 – October 30, 2014)
- Conducted waterborne system mounting, integration, and testing on the Severn River (September 16, 2014-October 30, 2014)
- Collected data on the Anacostia River at the Washington Navy Yard and the USS Barry. (November 1, 2014-December 8, 2014)
- Completed modeling of the SNM signature using MCNP software. (December 8, 2015-April 17, 2015)
- Completed research and analysis, report preparation, and results presented at the Trident Scholar Colloquium (April 24 – 25, 2015)
- Project Presented at the 2015 American Nuclear Society Student Conference in College Station, Texas (April 9-11, 2015)
- Project Presentation at the 2015 Hardened Electronics and Radiation Technology (HEART) - Technical Interchange Meeting, Conference in Chantilly, VA (April 21, 2015)

#### 3.2 Experimental Constraints and Limitations

Characterization of the ship effect required data to be collection on ship on the water near a ship. The following factors affected the execution of this project and were identified as sources of risk.

- Weather
- Sea state
- Temperature stability during data collection
- Watertight integrity and ability to operate system in marine environment
- Availability of ships
- Ability to provide mobile (afloat) power for duration of data collection
- Ability to collect and integrate accurate GPS data
- Ability to transport system to DC Navy Yard
- Availability of personnel to assist with utility boat launching

Successfully completing the project required that each of these risks and limitations be addressed. As a precaution, extra days were planned into the detection schedule so that poor weather or sea state could be addressed by postponing data collection.

The NaI detectors used in the data collection system were insulated so that they could function in varying temperatures. Extra precautions were taken to protect wire connections, including end caps bagging and taping. Over the data collection period there were zero technical difficulties with the detection equipment.

There were also equipment, environment, and time considerations that limited the effectiveness of the data gathering. These limitations were addressed by acquiring the largest and most effective neutron sensors available, acquiring the use of the largest boat available that could be towed to the Washington Navy Yard, and by devoting as much time as possible to on-water data collection. Range finders and other equipment were acquired or made ready to support the data collection process.

### **3.3 Facilities, Infrastructure, and Devices Used**

#### ***3.3.1 Facilities and Infrastructure***

For the waterborne measurements, the system was mounted on a 26 ft. open vessel. Specifics on the boat are included in the test plan, located in Appendix A. The vessel was provided by the Annapolis Naval Station. The Naval Station also provided a boat operator. A generator was used on board the boat to provide electrical power, along with a DC power supply required to support the MANS system. Data collection and signal processing in an exposed maritime environment also required an environmentally protected computer.

After characterizing the ship effect, significant computational processing was required. Modeling of the source signature emanating from a vessel was most effective on computers with parallel processing capability. All necessary hardware and software for modeling was either in place at USNA or was provided by the Department of Energy's Radiation Safety Information Computational Center (RSICC).

#### ***3.3.2 Details of Pre-Experiment Activities***

Before collecting data at the Washington DC Navy Yard, the system was assembled, integrated, and tested. The detectors that were used were originally three separate systems made to function on their own. The three detectors were called the MANS, MPS detectors, and Modular MPS detector. The details of the three detectors are provided in this section. One of the initial tasks was to successfully integrate all three of the detectors into one system that could be used on the boat. Figure 3-1 shows a notional schematic of how the three different detectors were connected together. The MANS detector was solely a  $^3\text{He}$  detector and stood alone. The MPS detectors and Modular MPS detectors were integrated in a single system, producing a single output file. The integrated system is called the Radiation Ship Effect Survey System (RSESS); a schematic of the system is shown in Figure 3-1.

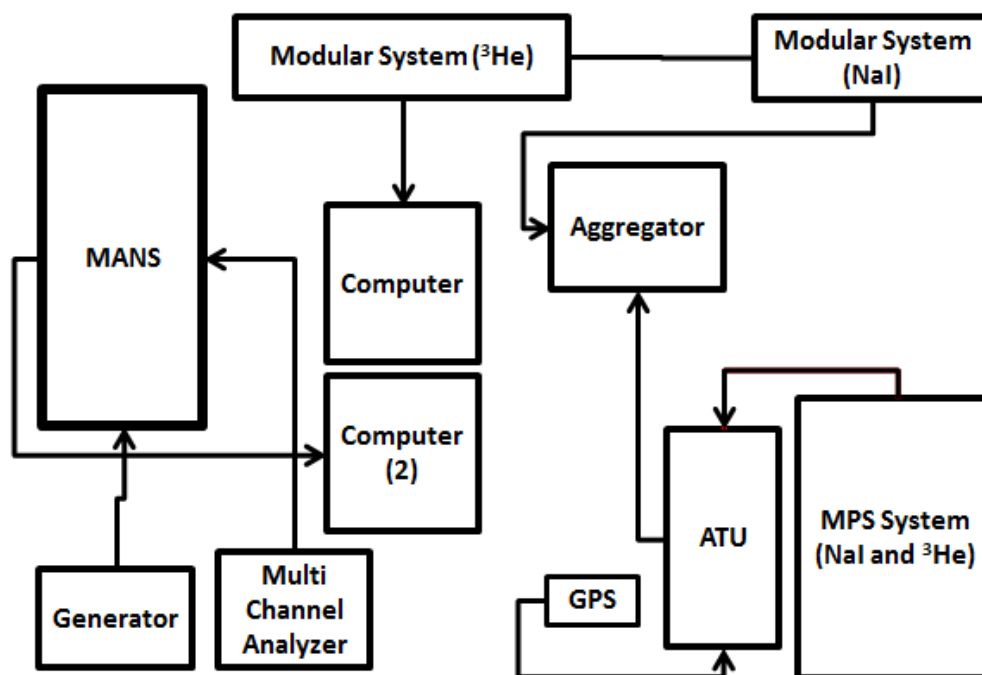

**Figure 3-1 A Schematic of the Radiation Ship Effect Survey System (RSESS)**

Initial testing and integration took place in the Rickover Hall Nucleonics lab. Once RSESS was integrated into an operational configuration, the mobility of the system was addressed. To support waterborne measurements, a mounting structure was built specifically sized to mount on the 26 ft. long vessel made available by the Annapolis Naval Station. With RSESS integrated, combined readings took place at different locations around the academy grounds to ensure data were recordable from all detectors. These readings were similar to the eventual measuring of the ship effect because they measured the naturally occurring radiation from different structures and materials around the yard. Although there were no known sources, there were still differences when readings were taken near buildings, structures and different materials.

Once the system performance capabilities were verified on land, the integrated system was mounted on the watercraft and testing began afloat. Initial waterborne testing involved readings taken from the Severn River near the Naval Academy. During this part of the project, the primary objective was operational testing and equipment familiarization. The data were also used to characterize the local surroundings and to ensure that the ship effect could be measured and identified near structures including the pylons of the Severn River Bridge. During this period, data were collected over the span from open water to the sea wall and the data showed clear evidence of the ship effect. Once RSESS was deemed functional for waterborne use, the focus of the data collection shifted to the Washington DC Navy Yard and the USS Barry.

### **3.4 Detectors Used in Data Collection**

As alluded previously, there were three different detection systems integrated together for creating a characterization of the ship effect. Each system was originally designed to be a stand-alone system, capable of collecting data and providing software interface to read such data. Even though the systems were integrated, the individual properties of each system are important in

data collection. This section shares some of the specifics for the different detectors. The MPS and Modular MPS systems specifics were found in the operating manual. The MANS detectors discussion was found through analysis of the system.

### **3.4.1 Modular MPS Systems $^3\text{He}$ and NaI<sup>22</sup>**

The Modular MPS system consisted of state of both NaI and  $^3\text{He}$  detectors.

The  $^3\text{He}$  Module has one set of three  $^3\text{He}$  filled tubes. Each tube is cylindrical in shape with a two inch diameter and a length of three feet. The  $^3\text{He}$  tubes feed into a neutron pulse monitoring module which outputs a Transistor-Transistor-Logic (TTL) pulse for each neutron detected. Using multiple tubes increases surface area, enabling the module to detect more neutrons. In addition, one side of the module is filled with High Density Polyethylene (HDPE), which acts as a moderator and vastly improves sensitivity to neutrons. The battery door is located on the moderator side of the module, and conventional orientation during data collection was with the battery door away from the ship. No attempt was made to explore directional sensitivity of the detector, but orientations were consistent.

The NaI Module has one 2" x 4" x 16" Sodium Iodide crystal. At the top of the crystal is the Photo-Multiplier Tube (PMT), which converts the energy from detected gamma rays into an electrical pulse that can be quantified with electronics. The crystal's large surface area enables the module to efficiently detect gamma rays. With more gamma rays being detected at a time, the integration time necessary to get desirable identification statistics is decreased. In addition to every module being shielded from electrical noise, the PMT is shielded from magnetic fields. Properly shielding the PMT eliminates calibration issues introduced from nearby magnetic fields (such as Earth's magnetic field, nearby motors, etc.).

### **3.4.2 MPS System (2 PODS)<sup>22</sup>**

The MPS System includes two identical and independent PODs. These PODs are watertight, EMI-shielded containers, which house gamma and neutron sensors and electronics. Each POD contains two 2" X 4" X 16" NaI sensors stacked vertically, with their largest surfaces sharing a common plane. High Voltage/Pre-Amp (HV/PA) caps are mounted on the end of each PMT.

Each MPS POD contains two neutron sensor modules, each comprising three 2" X 34" (active area), 3 atm,  $^3\text{He}$  sensor tubes mounted in a linear arrangement in an air-tight manifold, with a high voltage power supply and pulse shaping circuitry contained within the manifold. The two  $^3\text{He}$  modules are mounted on each side of the NaI gamma detectors, in a parallel orientation. Extensive information on these detectors is found in the operator's manual sited in the references, which will be provided in the final report.

### **3.4.3 MANS Detector**

The MANS (Modular Airborne Neutron Sensor) detector was originally designed for maximum neutron detection efficiency in airborne neutron surveys. The detector is a completely separate detector from the MPS system and the MPS Modular system. The MANS contains four 6" diameter 6-foot long  $^3\text{He}$  tubes. Each neutron sensing tube is pressurized to just above 1 atm. They are surrounded by polyethylene foam and polyethylene sheets. The intrinsic neutron detection efficiency is reported to be close to 30% (exceptionally high) though this efficiency has not been validated.

## 4 Data Collecting Process

### 4.1 Initial Testing and Detector Validation

Appendix A contains the test plan that was prepared to serve as a guide for all pretest activities and testing operations. Included in the test plan are objectives, scenarios, and qualifying results. For extensive details pertaining to the execution of testing at the USS Barry refer to Appendix A. An overview of some of the factors is given in this report.

Testing on land and water initially took place at the Naval Academy and was focused on operational verification, position accuracy, and becoming familiar with the equipment.

### 4.2 Experimental Scenarios

Data collection scenarios included both dynamic and static data collection. The dynamic measurements included slow sweeping motions in the area being surveyed, with the objective of providing spatial coverage of the entire region where detection activities were conducted. Static data collection was conducted at key points spaced throughout the survey zone including end points and points at distinct ranges from the vessel. Figure 4-1 shows approximate lines of approach along which static measurements took place. A line, tied from the ship to an anchor, was used to hold the boat in each position for 10 minute data collection periods.

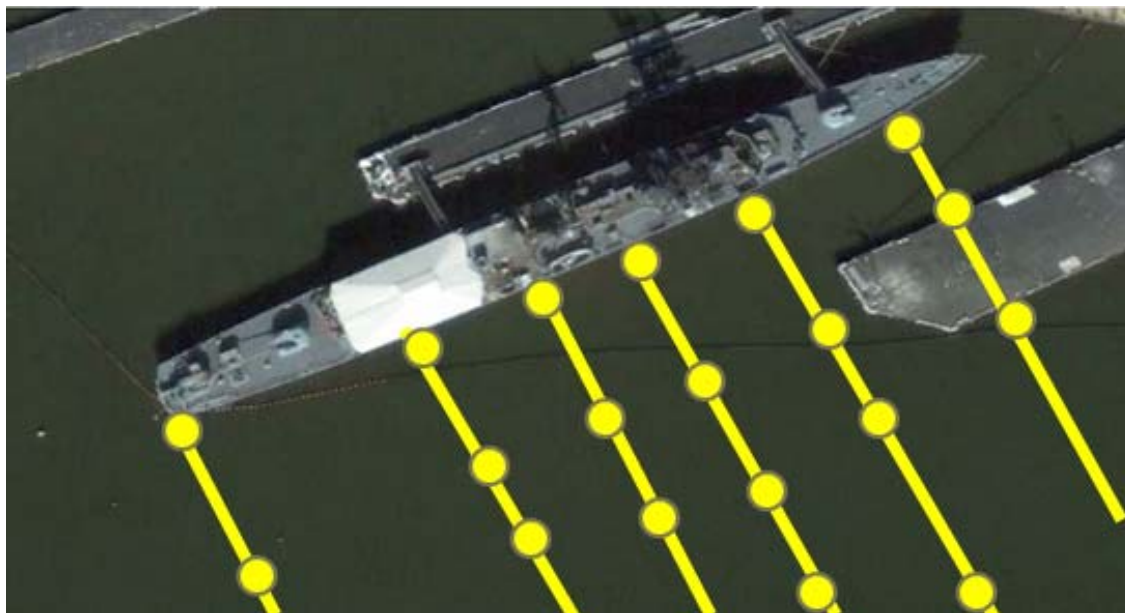

**Figure 4-1 Static locations of actual data collection**

This survey method shown in Figure 4-1 allowed for the generation of a two dimensional map of ship effect using equipotential lines as in a contour map. Daily baseline background measurements were taken from an area in the Anacostia River that was assumed, and later confirmed, to be outside of the effect of the ship's increased background radiation.

### 4.3 Challenges to testing process

The greatest challenges experienced in data collection were in the physical stationing and position keeping during the static collection scenarios. As shown in Appendix A, Figure A-3-5, the original plan included close to 100 data points. Because of challenges involved in

maintaining positions for a ten minute period, and the data that was being collected, this number was reduced. In all, for the static mapping of the area around the USS Barry 56 static readings were taken. Figure 4-2 and Figure 4-3 depict the static data collection taking place.



**Figure 4-2 Edgewater shown next to the USS Barry collecting data**

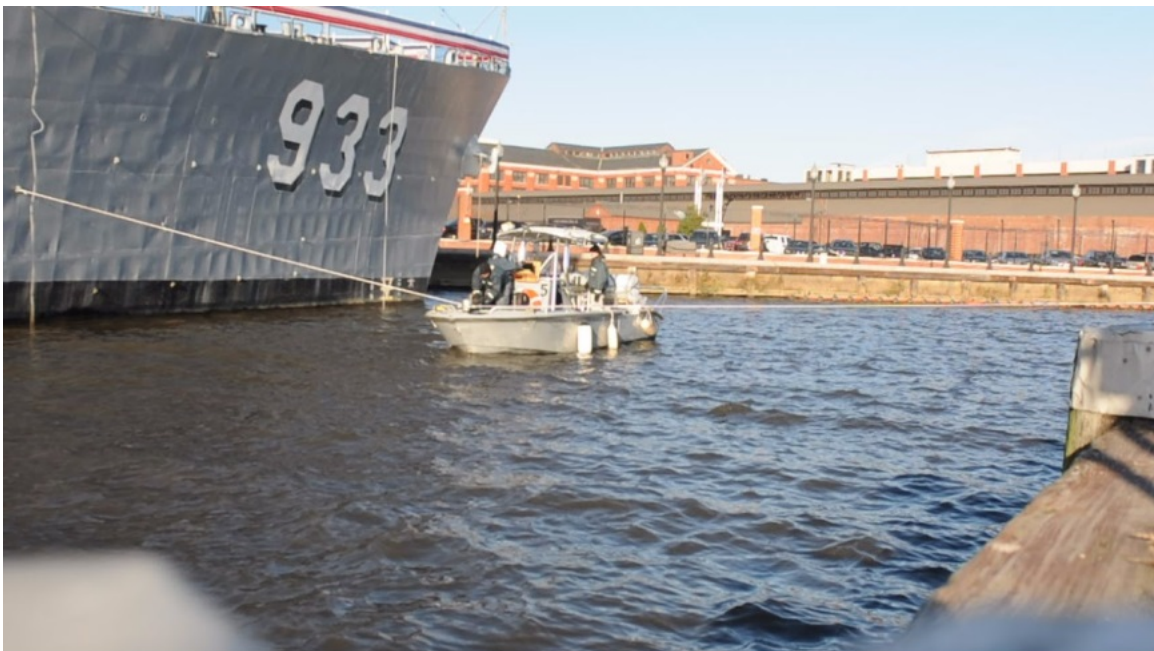

**Figure 4-3 Static Measurement taken at a specific distance from the USS Barry**

## 5 Measured Results

### 5.1 Survey for Sources

Variations in background neutron radiation can be associated with source material or associated with irregularities in the environment. Therefore, to ensure the measurements made were only attributable to the ship effect and not to any source material, an on-board survey was conducted checking for notable variations in the amount of radiation received or a spectral signature indicating source material. The USS Barry was surveyed onboard the ship using the modular MPS Systems and other neutron and gamma radiation detectors. These surveys were meant to identify radiological sources that could influence ship effect measurements. To ensure statistically sound data, each of the surveys was made over a ten minute span. The results of the neutron and gamma spectrometry measurements indicated no sources on board, so the off-hull measurements were a result of the ship effect alone. Gross count results of the on-board measurements are shown in Table 5-1.

**Table 5-1 Onboard Survey of USS Barry**

<b>Location on USS Barry</b>	<b>Gamma Counts per Second</b>	<b>Neutron Counts per Second</b>
<b>Aft (3<sup>rd</sup> Deck)</b>	313	1.15
<b>Mid-Ship (2<sup>nd</sup> Deck)</b>	445	1.49
<b>Forward (3<sup>rd</sup> Deck)</b>	358	0.99

The increase indicated in the Mid-Ship section of the ship is attributed to the ship effect with the greater amount of mass located near that location when compared to the forward and aft portions of the ship. Therefore, data measured both on and off the ship were assumed to be only a function of the ship effect, and not from any irregularity on board the USS Barry.

### 5.2 Location of highest radiation on the USS Barry

Neutron ship effect background radiation is a result of the interactions with higher atomic number material, so it was expected that the greatest observable ship effect would correspond to the ship's center of mass. This was confirmed in the measurements made along the hull of the ship. Figure 5-1 shows the results of measurements taken along the hull. These were taken as depicted in Figure 4-2, and show that there was an increase in the amount of radiation near the superstructure. These results shown are based on data collected with the MANS detector. The data were taken on different days, but were normalized based on the daily background measurements.



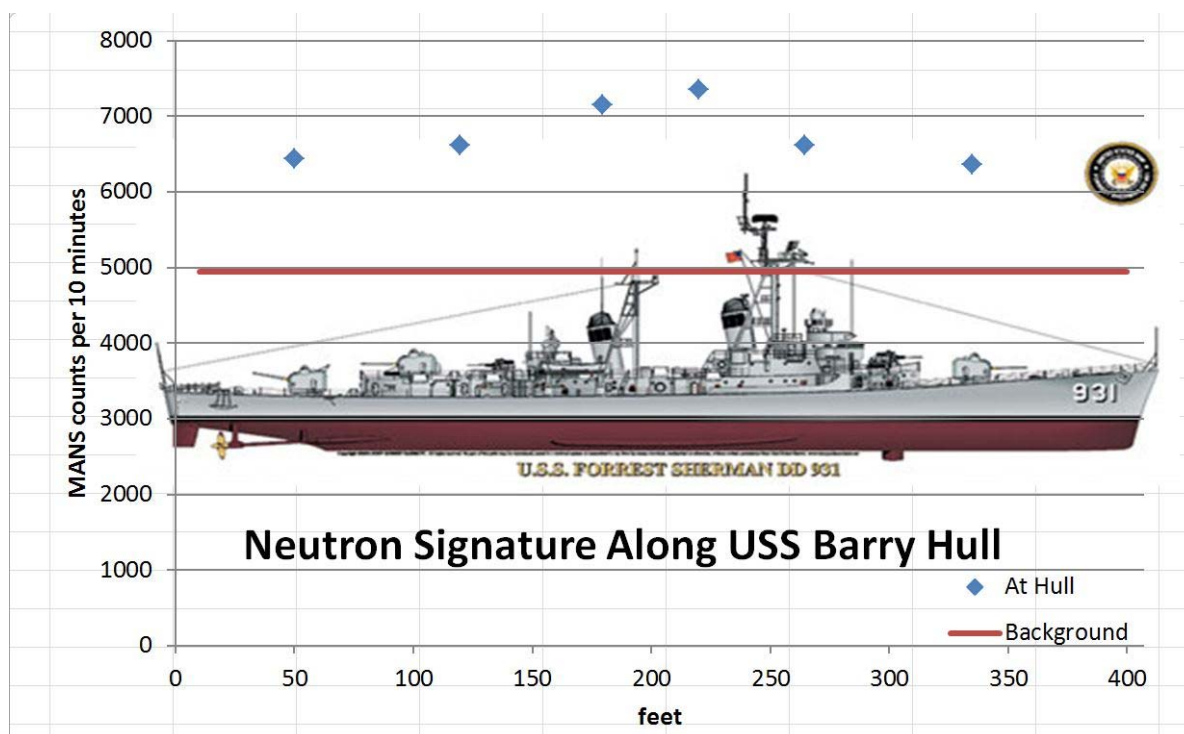

**Figure 5-1 Ship effect measured along the hull of the USS Barry**

These results both confirm and quantify the anticipated ship effect, or natural increase in background radiation associated with massive higher atomic number material. Figure 5-1 and Figure 5-2 both show the ship effect measured around the hull of the USS Barry. Figure 5-2 differs in that it only represents the results measured on the MPS systems, and that the results were averaged over the 10 minute static data collection interval to produce a neutron per-second count rate (cps). Note that the MANS system (Figure 5-1) showed more than twice the count value of the combined MPS and MPS Modular systems (Figure 5-2). Comparing totals as counts per second (Figure 5-2) is useful because it gives a better quantification for how the detectors would immediately respond to being in the area. In addition, many detection systems return readings based on neutron counts per second, so these reduced data are relevant. Since the count rates are based on a ten minute static data collection interval, the total error is still minimal, and therefore even modest variations in count rates per second (cps) shown represent measureable changes in the number of neutrons counted over the ten minute period.

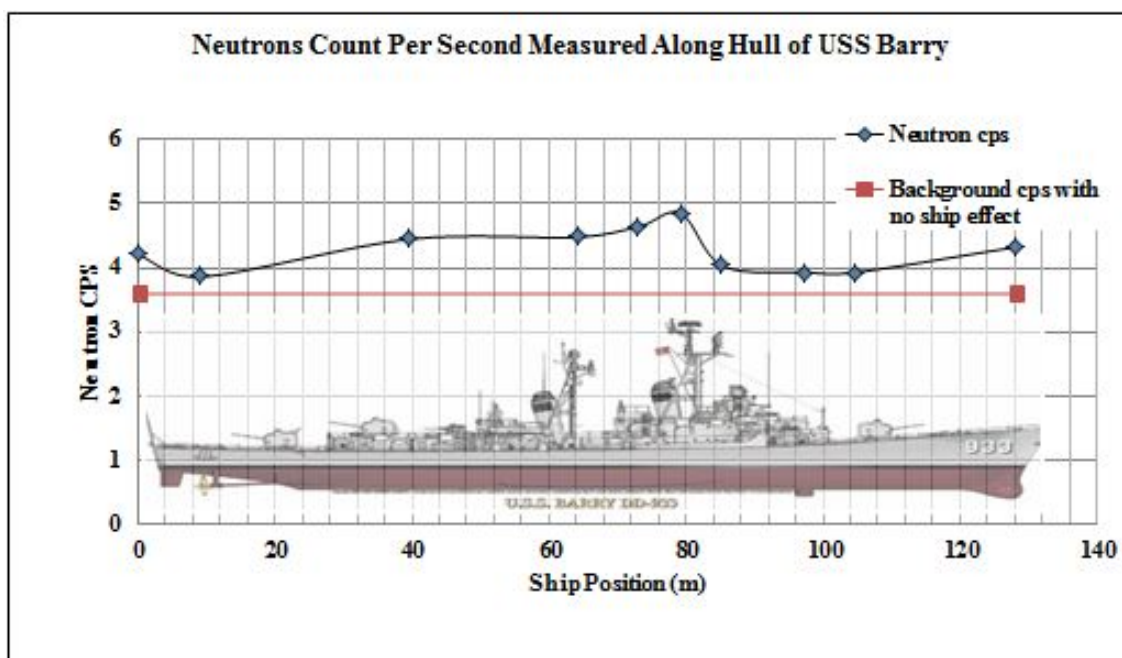

**Figure 5-2 Neutron cps near the hull of the USS Barry (MPS and Modular Systems)**

The forward superstructure was the location with the highest amount of neutron radiation background.

### 5.3 Radiation vectors out from the USS Barry

Once the baseline background was established each day, arrays of survey points were taken between November 5, 2014 and November 25, 2014 in an attempt to characterize the area surrounding the USS Barry. Consistent with the measurements shown in Figure 5-1 and Figure 5-2, the background counts consistently increased on approach and in particular near the center of the USS Barry. The data were normalized to the background measured on each day. The background baselines that were used to both confirm functionality and provide a way to normalize data collected over a one month span are shown in Table 5-2.

**Table 5-2 Background measured with associated weather**

Date	MPS/Modular Systems Neutron cps	MANS Neutron cps	Total	Temperature (°F)	Humidity (%)	Wind (mph)
Nov. 5	3.2	8.2	11.4	68	42	5
Nov. 12	3.5	8.2	11.7	63	39	9
Nov. 19	3.8	8.7	12.5	36	30	8
Nov. 25	3.9	8.7	12.6	56	50	0
Average	3.6	8.5	12.1	N/A	N/A	N/A

An attempt was made to draw subjective correlations between daily baseline background levels and environmental factors through recording and comparing variation of temperature, precipitation, humidity, and wind. Over the data collection period, there was no correlation seen between the variation of background readings and weather. No attempt was made to correlate with solar activity or other factors, and the variations were assumed to be caused by long term (> 1 day) effects, so the measured variations served as the basis for normalizing the daily data collected. Note that the values represented in Table 5-2 are reduced from ten minute values, so the variation seen is far more than that expected due to statistical fluctuation alone.

The normalized data showed good consistency with increased signal on approach of the USS Barry. Figure 5-3 and Figure 5-4 show the results of the data collected using the MPS and modular systems. The data were all collected over ten minute static periods and then reduced to neutron counts per second (cps) in the figures. Note that the apparent contour artifacts along the outer contours are at very low background levels, and may be related to the fit algorithm. All data in the increased background region show a high level of consistency. Also note that an overhead image of the USS Barry has been placed at the ship's location with respect to the collected data; showing how the radiation increased as distance to the ship decreased.

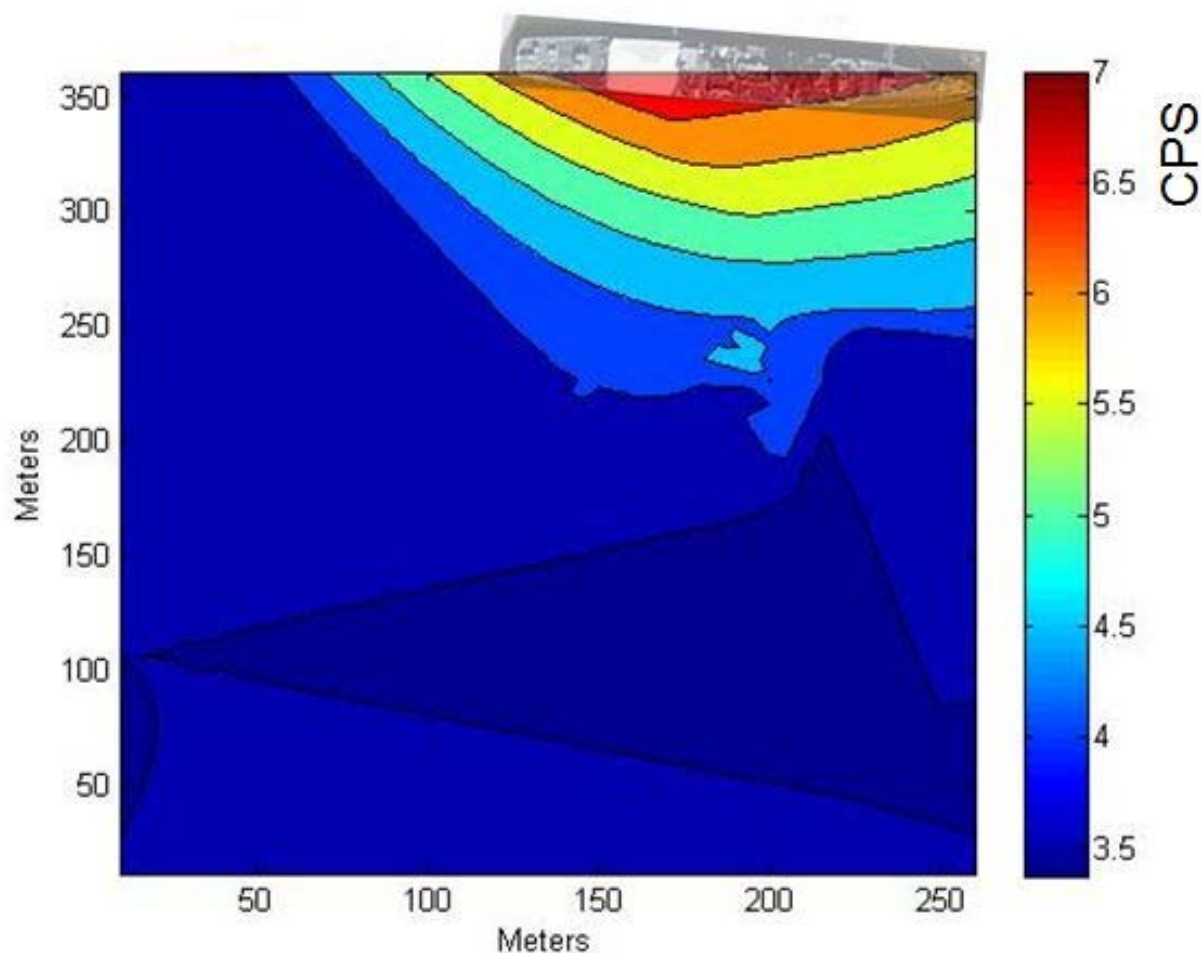

**Figure 5-3 Contour plot of ship effect (MPS Systems)**

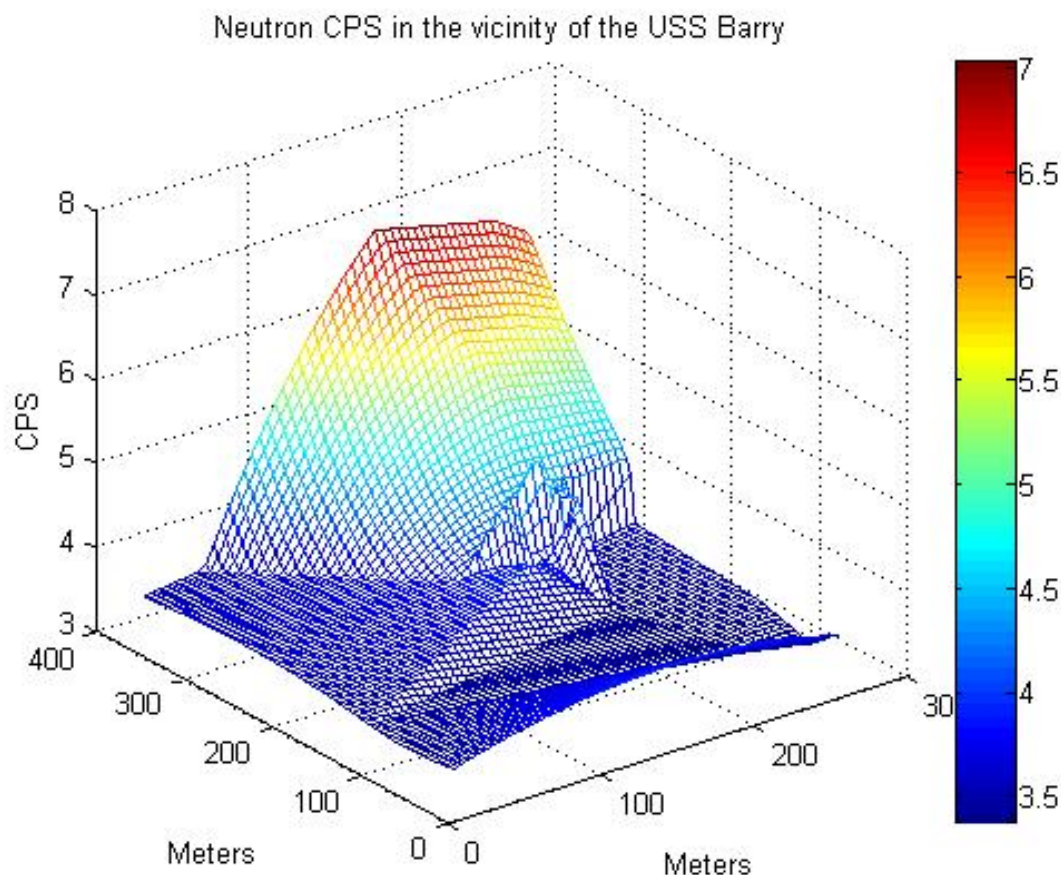
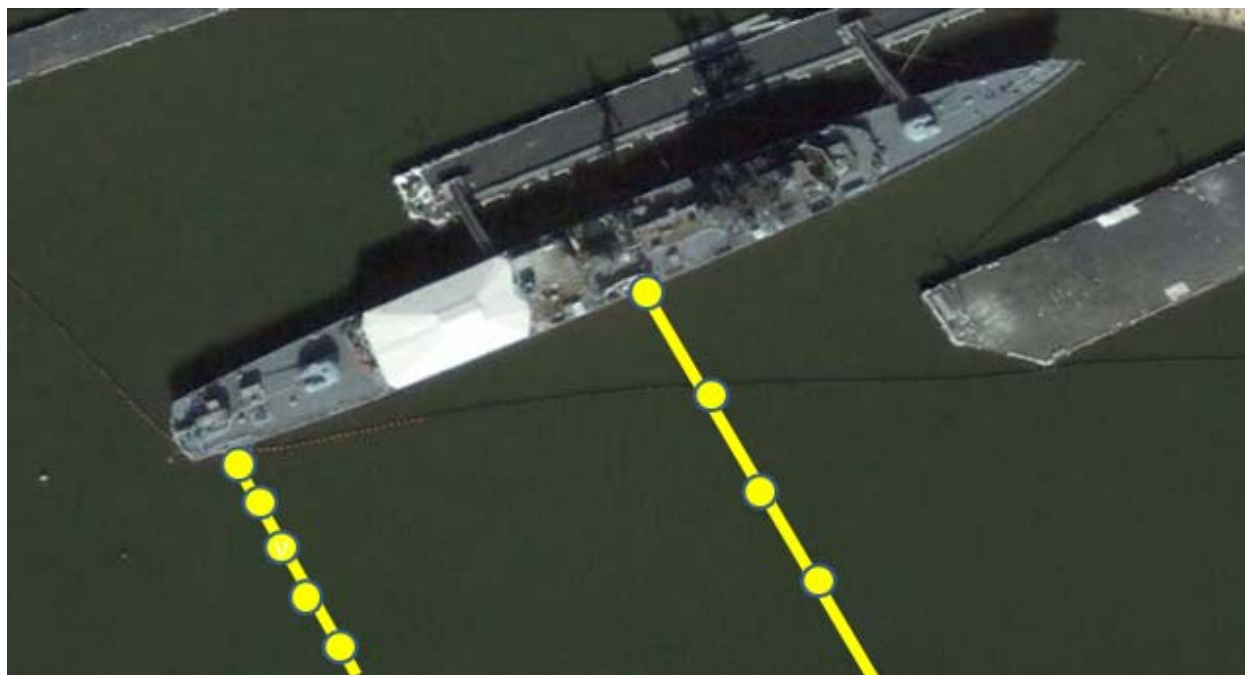

**Figure 5-4 3D plot of ship effect (MPS Systems)**

Figure 5-3 and Figure 5-4 show the same data in two different plot types. In both cases, the peak levels are adjacent to the hull of the USS Barry. In order to combine the data taken over different days, the sensor data were normalized to each day's background. Creating the plotting space required that the corresponding average GPS coordinates be converted to Universal Transverse Mercator (UTM) coordinates to simplify x-y plotting and show spacing. The data were then imported into MATLAB. Within MATLAB, a scattered interpolate function was created so that the whole area could be filled with data points. Once the function was created, the results were plotted. The plotted positions are based on the average GPS fix over the ten minute static interval, with typical GPS variations showing less than 10 feet of movement during the data collection. With the UTM conversion, survey values collected at the furthest south and west points ended up defining the origin of the graphs. Due to the orientation of the ship this point represents the furthest distance from the bow of the ship. The plot includes interpolation and extrapolation, including into space actually inside the ship; so the shown increase up to 6.5 cps is artificial and located inside the ship. The actual highest measured count rate over a ten minute interval was 5.0 cps. Based on a background average of 3.5 cps, the maximum increase in neutron background due to the ship effect was found to be 43% based on MPS and Modular MPS data and 50% based on MANS data for the USS Barry. Other ships may exhibit more or less than this, depending on materials, mass, and surroundings.

Additionally, note that Figure 5-3 and Figure 5-4 indicate the measurable range of the ship effect. There was nominal statistical variation in the data as the ship was approached until approximately 85 meters from the hull. Figure 5-3 illustrates that the increase begins at an area approximately 240 meters from the bottom axis, corresponding to ~85 meters from the hull. Figure 5-3 also shows that it increases continually to the hull's edge; which is depicted to be between 325 meters and 350 meters from the bottom axis. This equates to the characterization that the ship effect was not measurable at further than 110 meters from the ship, but generally, consistent effects were detected out to 85 meters from the ship.

Along with the Modular and MPS systems, the MANS detector was also used to characterize and measure the ship effect. Consistent with other systems, the MANS detector confirmed that there was an increase in the number of neutrons being counted as the approach to the USS Barry was made. This was found while measuring the different vectors when approaching the ship. Two of those vectors are shown in Figure 5-5.



**Figure 5-5 Two specific paths used to characterize ship effect**

The data collected at these approximate locations are shown in Figure 5-6. There exists a noticeable increase from the background levels to the levels detected at less than 10 meters from the hull. The data shown here were collected over 10 minute data collection periods.

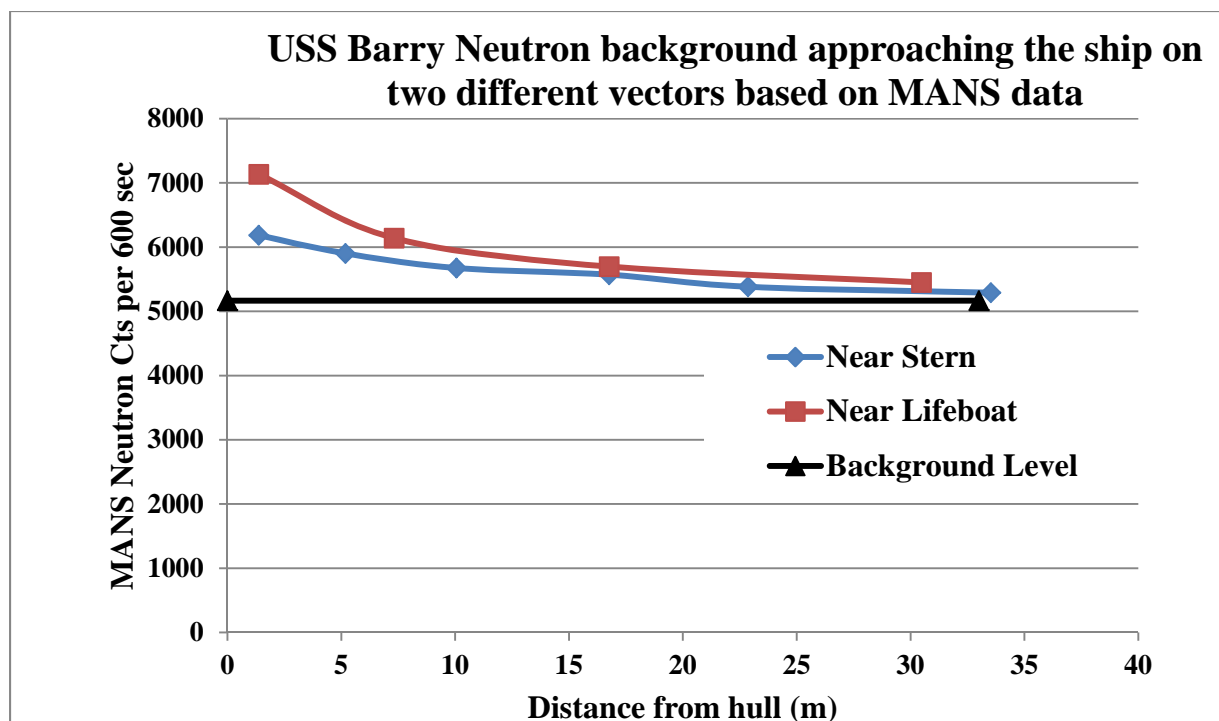

**Figure 5-6 Background neutron radiation detected approaching the ship**

The data collected with the MANS detector was eventually all combined and normalized based on daily varying open water backgrounds. Similar to the MPS Systems, but based on significantly higher response, the MANS detector showed similar ship effect. These results are shown in Figure 5-7, with the ship superimposed over the contour.

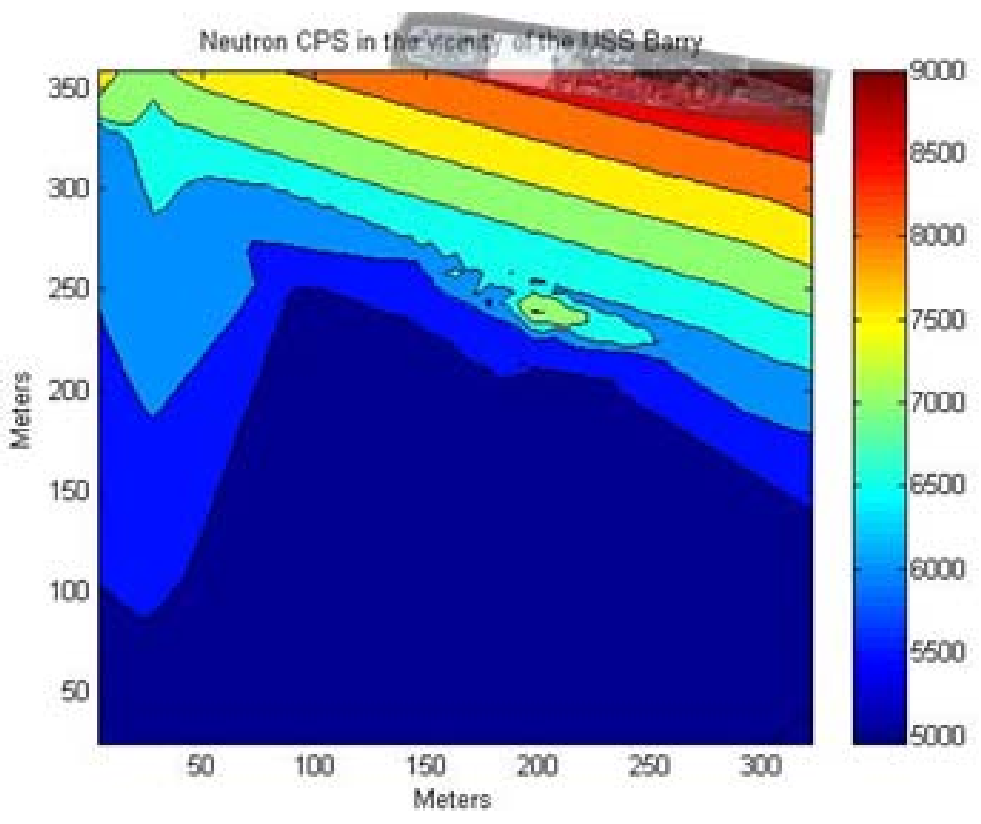

**Figure 5-7 Contour plot of ship effect measured by the MANS detector**  
The increase in the neutron background radiation was found to be consistent in both magnitude and extent for both MANS and the combined MPS systems.

## 6 Analytical Modeling

Since the 1940's software tools for radiation transport analysis have been in use and development. One of the popular computational methods employed is the Monte Carlo method, where numerous individual particle histories are simulated using both random numbers and known reaction data. After an adequate number of histories are tracked, a picture of the radiation transport for a particular problem emerges from the statistical noise (noise that results from the randomness inherent in the approach). One popular tool is Monte Carlo N-Particle (MCNP) developed and maintained by Los Alamos National Laboratory<sup>23</sup>. Using this software, radiation transport simulations were performed to determine the signature emitted by a notional illicit source placed on board the USS Barry. The location, size, material, and shielding was somewhat arbitrarily selected, not necessarily representing anticipated nuclear material or an anticipated stowage location or configuration. Simulated source signature data were generated over the same spatial zone as already characterized with empirical background data. A statistical analysis was conducted, assuming Poisson counting statistics, to determine both feasibility of detection and the role the ship effect plays in this feasibility. By employing the Currie Criterion with simulated source signature data in two scenarios - one with no ship effect and one with measured ship effect – the impact of ship effect on detection range was determined. Note that this determination was based on an alarm algorithm constantly aware of the increase in background due to the ship effect; clearly an unrealistic assumption but necessary to complete the analysis.

### 6.1 MCNP Input File

In order to simulate the signature emitted from a vessel due to a notional illicit nuclear source, a simplified model was constructed. For the SNM, a simple spherical configuration of a significant quantity of SNM (plutonium in this case) was modeled with a radius based on unclassified bare criticality standards and a mass based on IAEA's definition of "significant quantities" of SNM<sup>24</sup>. These models included varying the location of the source; with the source inside of one bulkhead, two bulkheads, and beneath the waterline. The detector was also varied in location and size. Initially the MANS detector was modeled and then a much smaller and more typical <sup>3</sup>He detector was modeled in the same varying locations. These varying detector locations were used to analyze the effect of distance on detection feasibility. The ship model was a highly simplified version of the USS Barry but adequately represented the ship for purposes of radiation transport analysis. Results from the simulations were combined with the measured data to assess the impact of ship effect on detection distance. Figure 6-1 is a depiction of the model that was created for MCNP with the source shown immediately adjacent to and inside the hull. Other source locations were modeled and the analysis reported here is based on results from a model with the source location near the center of the ship at waterline. The only attenuation materials included inside the vessel were air, a steel bulkhead, and the steel hull.



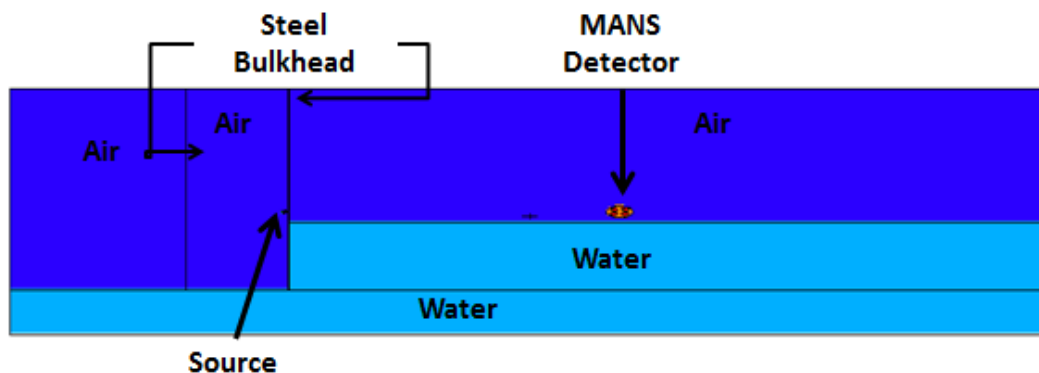
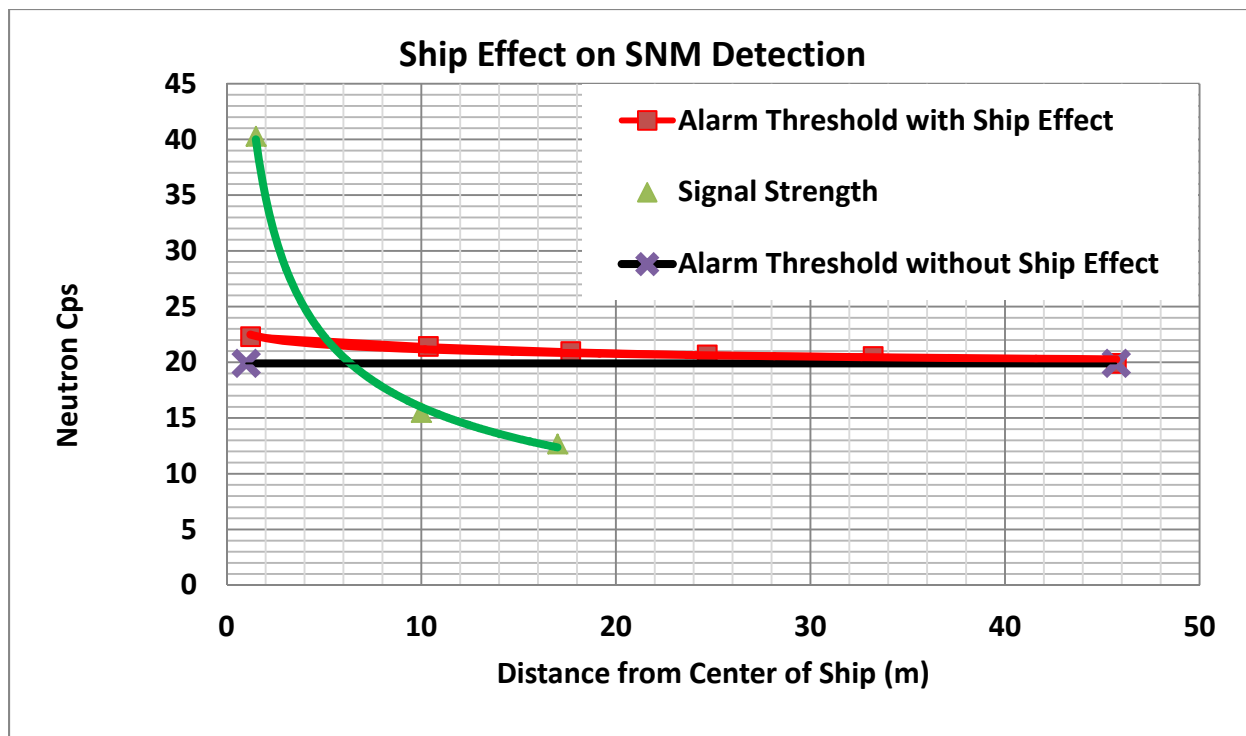

Figure 6-1 Visual depiction of the MCNP input

## 6.2 SNM Modeled with the Ship Effect

The MCNP model simulated the number of neutrons that would be detected by the MANS detector from a source located inside the ship as shown in Figure 6-1. Using the simulated detector response values at varying distances from the ship, Figure 6-2 shows differing alarm thresholds at different distances from the ship in the case where the ship effect background is known and the alarm threshold is based on the varying background. The green line in Figure 6-2 represents the total detector response versus range from the hull. The “Alarm Threshold with Ship Effect” is the response necessary for detection with 95% confidence based on the Currie Criterion and based on foreknowledge of the ship effect. Note that the alarm will occur with the stated confidence at the point where the threshold line intercepts the signal strength line. Also note that the open water background level (not shown on the Figure) is at a value of 12.7 cps. In the case without ship effect, the threshold is constant at approximately 20 cps.

The difference between the intercept points of the “Signal Strength” with the “Alarm threshold with Ship Effect” and the “Signal Strength” with the “Alarm Threshold without Ship Effect” represents the impact that the ship effect would have on detection capability for this nominal scenario. In this case, the point of detection with 95% confidence is decreased from six meters to five meters due to the ship effect. This 20% decrease in the detectable range may be significant if a survey vessel is limited in its ability to maneuver close to an inspected ship. Note that the assumptions made in this analysis limit the direct applicability of the results, but the overall effect of decreased distance at which detection will occur is generally applicable.



**Figure 6-2 Thresholds for SNM detection with and without the ship effect**

### 6.2.1 SNM Modeled with Ship Effect and a Smaller $^3\text{He}$ Detector

Access to a detector the size of the MANS detector is limited. Therefore, another model was built to show the impact of the ship effect and background on off hull detection of SNM. Based on background measurements made at the Naval Academy, the smaller  $^3\text{He}$  detector captured neutrons at 10% of the rate compared to the MANS detector (the MANS detected neutrons at about 8 cps compared to the smaller  $^3\text{He}$  detector's rate of 0.8cps). Using the difference in measured background response as a correlation factor, ship effect data were adjusted for the smaller  $^3\text{He}$  detector. Scaling the measured data at the USS Barry given by the MANS detector provided approximate background data for analysis. Note that with the lower sensitivity, the difference between number of neutrons captured and the number of neutrons needed to reach the alarm prevents an intercept off hull. In other words, the detector's response will not reach the alarm threshold in order to detect SNM on a ship as shown in Figure 6-3. Note that in this case, the inability to detect the notional source applies with or without the ship effect.

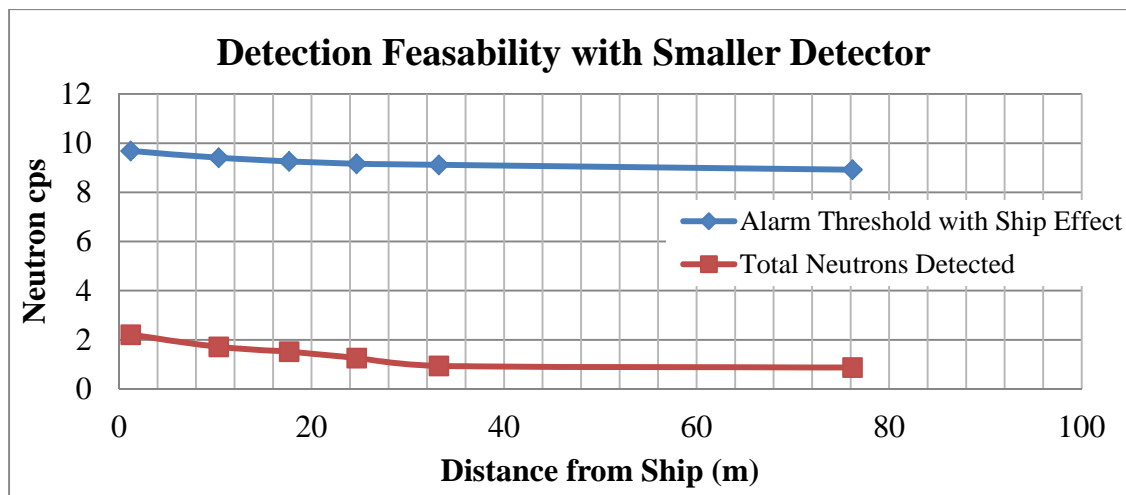

**Figure 6-3 Alarm Threshold for SNM Detection Using Smaller Detector**

Even with the presence of SNM as modeled in MCNP, the alarm threshold caused by the certainty threshold to 95% was never reached off hull. Therefore, if this were an actual scenario, the small  $^3\text{He}$  detector could not be reliable for detecting SNM in an off hull detection situation, regardless of ship effect background.

### 6.3 Increase in False Positives (False Alarms) from Shifting Mean

Data collected confirm the increase in neutrons detected as the ship was approached due to ship effect alone. The MANS detector's average open water background was 8.5 cps. Comparable to the increase in the count rates measured by the MPS Systems, the MANS detector experienced an increase to as high as 12.7 cps; a 50% increase. Implications of this increase of background must be considered in conjunction with the detection algorithm used. One common mode of detector alarm is to trigger a response at a given increase in the count rate received. Often the threshold on the detector is set a certain level above background where the chance of exceeding the threshold without an actual source present (false positive), is small. As discussed earlier, a 95% confidence threshold will result in less than 5% false alarms. While this number may seem low, the implication is that 5 of 100 surveys, or one in 20 surveys can result in a false alarm. If the system is based on one second time intervals, this would be approximately one false alarm in 20 seconds. Such a false alarm rate could make operational surveying impossible. Operational alarm thresholds would likely be set at a much higher level than the 95% threshold.

In the case where the background is increased, but the alarm setting is constant, the ship effect increases the false alarm probability. Figure 6-4 shows the mean distribution of the combined data from the two detectors. It also includes an alarm threshold set at three standard deviations above the mean, resulting in a false alarm probability of 1%. In other words, the area under the blue line and to the right of the green line is 1% of the overall area under the curve. With an upward shift in the mean value due to ship effect, indicated by the red line, the new statistical distribution shows significantly higher area above the fixed alarm threshold, indicating a significant increase in false alarm probability. In this notional case, the increase in false alarm probability is from 1% to 6.5% - again a value that would cause significant difficulty for operational surveys.

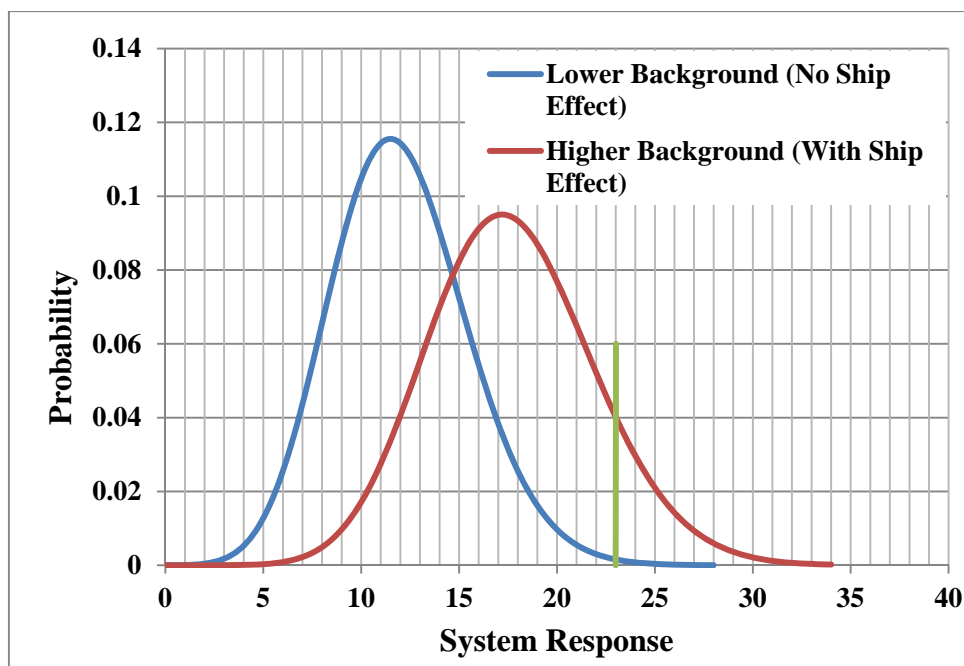

**Figure 6-4 False Alarm Analysis of Ship Effect with MANS detector**

The measured results of the ship effect taken with the MPS and Modular Systems illustrate the same principle but at lower count rates. The effect on false alarm probability is similarly a large increase in false alarms. Similar to Figure 6-4, Figure 6-5 illustrates the impact of the ship effect on false alarms may be unacceptable when applying a constant threshold alarm algorithm.

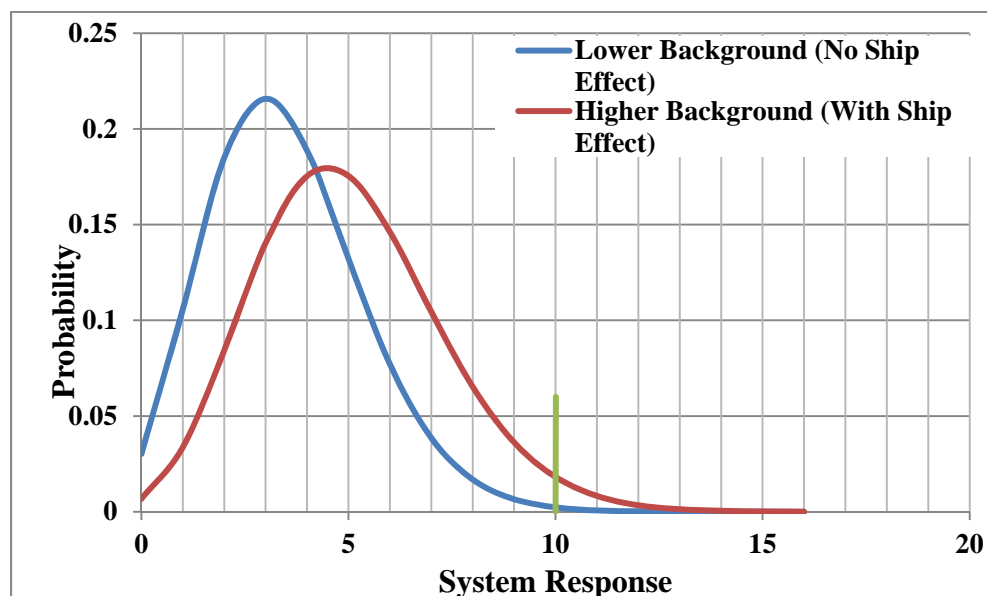

**Figure 6-5 False Alarm Analysis with Ship Effect for MPS detectors**

Analysis made using the mean numbers indicated that at a constant alarm setting at 1% false alarm probability for an unaffected background will increase in a ship effect environment to

approximately 10%. Therefore, from a practicality standpoint, the system would receive ten times the number of false positive readings, making the operational survey more difficult.

## **7 Project Outcomes**

This Trident project has provided the following: a measured spatial characterization of the background radiation surrounding a ship; a simulation of radiation emitted by special nuclear material and transported outside a ship; and an analysis of the feasibility of detection. Outputs provided in plots, tables, and discussion showed that the material differences between the iron of the ship and the elements of the water results in an increase in amount of natural neutron radiation. Information produced in this project will be useful in the analysis of current equipment, the development of future equipment, and the development of Concept of Operations (CONOPS) in the interdiction of nuclear materials out of regulatory control in the maritime domain.

### **7.1 Summary of Measured Results**

It has been shown that for a 4,000 ton warship, the magnitude of the ship effect is an increase in neutron background of 50% compared to open water background levels. Further, the magnitude of the ship effect varies in both distance from the hull and position along the hull. The highest increases were seen near the ships center of mass. The ship effect is seen to drop off with range from the ship with measureable increase scene out to 85 meters from the hull. Note that standoff detection will likely occur well within this range.

### **7.2 Summary of Detection Feasibility Analysis**

The modeling of an SNM source and the placement on board the modeled ship were entirely notional. Therefore, results cannot be applied to any general encounter scenarios, but, the results do provide a general assessment of overall impact of ship effect on detection. Based on the use of the MANS detector and the notional source, detectable distance decreased 20%. In addition, false alarm probability based on an alarm threshold set three standard deviations above the mean increased by a factor of 10 due to the ship effect. Therefore, this will have a major impact on interdiction and survey CONOPS.

### **7.3 Future Work**

This research considered only a single naval vessel. Although results were conclusive, they are restricted in applicability. A more thorough study of different types of vessels, including commercial vessels and different types of cargo, will provide more general characterizations of the ship effect.

Beyond maritime interdiction, the search for SNM is also of interest in the vicinity of venues that may present a target to terrorists; for example, large stadiums. These venues will also exhibit the ship effect. In order to maximize the effectiveness of survey protocols, a thorough understanding of the varying spatial neutron background is needed. With the integration of the equipment already completed, such a survey could be conducted following similar means used in this research.

As noted in this report, gamma and neutron signatures were collected simultaneously but gamma signatures were not analyzed. An analysis of the gamma data could provide useful information in

a consideration of stand-off survey by gamma signature. It is expected that the gamma data will show similar ship effect trends in the vicinity of the vessel.

## References

---

- <sup>1</sup>NOAA. (n.d.). *Ocean Service*. Retrieved February 4, 2014, from NOAA: [oceanservice.noaa.gov/facts/shorelength.html](http://oceanservice.noaa.gov/facts/shorelength.html)
- <sup>2</sup> Strategy, U. N. (n.d.). *White House*. Retrieved January 2014, from [http://www.whitehouse.gov/sites/default/files/rss\\_viewer/national\\_security\\_strategy.pdf](http://www.whitehouse.gov/sites/default/files/rss_viewer/national_security_strategy.pdf), May 2010
- <sup>3</sup> Dhs. (2002). *Maritime Security Strategy*. Retrieved January 2014, from [http://www.dhs.gov/xlibrary/assets/HSPD13\\_MaritimeSecurityStrategy.pdf](http://www.dhs.gov/xlibrary/assets/HSPD13_MaritimeSecurityStrategy.pdf), 2002
- <sup>4</sup> IAEA. (2013, August). *Incident and Trafficking Database*. Retrieved from <http://www-ns.iaea.org/security/itdb.asp>,
- <sup>5</sup> Estanislao Aguayo, R. T.-2. (2013). *Ship Effect Neutron Measurements and Impacts on Low-Background Experiments*. PNNL-22953.
- <sup>6</sup> John D. Dirk, M. E. (December 2003). *Terrestrial Thermal Neutrons, IEEE Transactions on Nuclear Science, Vol. 50*.
- <sup>7</sup>WMD, H.-t. n. (2014, February 3). *PNNL.gov*. Retrieved from <http://www.pnnl.gov/news/release.aspx?id=405>
- <sup>8</sup> Systems, T. o. (2014, February 3). *nist.gov*. Retrieved from <http://www.nist.gov/pml/div682/grp04/radiation-detection.cfm>,
- <sup>9</sup> John D. Dirk, M. E. (December 2003). *Terrestrial Thermal Neutrons, IEEE Transactions on Nuclear Science, Vol. 50*.
- <sup>10</sup> V.D. Scott, P. J. (2009). *Investigation of the “Ship Effect” in Off-Shore Screening for Nuclear WMD*. Senior Design Project Report
- <sup>11</sup> Gary W. Phillips, D. J. (2005, July). *A Primer on the Detection of Nuclear and Radiological Weapons, Gary W. Phillips, David J. Nagel, and Timothy Coffey, Center for Technology and National Security Policy, National Defense University*. Cener for Technology and National Security Policy, National Defense University.
- <sup>12</sup> Cook, B. (2014, February 3). *Gone Fission: MSC ships test radiation detection*. Retrieved from [msc.nav.mil](http://www.msc.navy.mil/sealift/2004/March/radiation.htm): <http://www.msc.navy.mil/sealift/2004/March/radiation.htm>
- <sup>13</sup> Kouzes, R. T., Ely, J. H., Seifert, A., Siciliano, E. R., Weier, D. R., Windsor, L. K., . . . Buc. (2008). *Cosmic-ray-induced ship-effect neutron measurements and implications for cargo scanning at borders*. Richland, WA: Pacific Northwest National Laboratoy.
- <sup>14</sup> EPA. (n.d.). The Atomic Energy Act of 1954., (p. Section 2 iitem e. Page 10 of Act). Retrieved January 11, 2014, from <http://www.epw.senate.gov/atomic54.pdf>
- <sup>15</sup> R. C. Baumann, T. Z. (1995). *Boron compounds as a dominant source of alpha particles in semiconductor devices*. Las Vegas, NV: Proc. 33rd Annu. IEEE IRPS.
- <sup>16</sup> Geelhood, D. B. (2014, January). Personal communication with Dr. Bruce Geelhood. Oak Ridge, TN.

- 
- <sup>17</sup> Mewaldt, R. A. (n.d.). Cosmic Rays. California Institute of Technology. Retrieved January 2014, from [http://www.srl.caltech.edu/personnel/dick/cos\\_encyc.html](http://www.srl.caltech.edu/personnel/dick/cos_encyc.html)
- <sup>18</sup> Glenn F. Knoll, W. (2000). Radiation detection and Measurement. *3rd Edition*.
- <sup>19</sup> Farlex. (2015, April 20). *The Free Dictionary*. Retrieved from <http://medical-dictionary.thefreedictionary.com/normal+distribution>
- <sup>20</sup> Junstin C. Langan, M. J. (October 7, 2009). *Evaluation of Aerial Radiation Detection Identification and Mapping System (ARKIMS) For Detection of Neutron Sources*. Fort Belvoir, VA: Defense Threat Reduction Agency.
- <sup>21</sup> C. S. Blessinge, R. L. (November 2006). *Neutron Detection Algorithm Development*. Oak Ridge National Laboratory, Nuclear Science and Technology Division. Retrieved April 20, 2015, from <http://web.ornl.gov/~webworks/cppr/y2007/rpt/125365.pdf>
- <sup>22</sup> SPAWAR, N. P. (2013). *Modular MPS Manuel*. SPAWAR
- <sup>23</sup> Goorley, J. (2013). Initial MCNP6 Release Overview - MCNP6 version 1.0. *LA-UR-13-22934*.
- <sup>24</sup> IAEA Safeguards Glossary. (2001). Retrieved January 2014, from [http://www-pub.iaea.org/MTCD/publications/PDF/nvs-3-cd/PDF/NVS3\\_prn.pdf](http://www-pub.iaea.org/MTCD/publications/PDF/nvs-3-cd/PDF/NVS3_prn.pdf)



**APPENDIX A**

**Test Plan for the Ship Effect Characterization of the  
USS Barry at the Washington Navy Yard**

(September 2015)

MIDN Fletcher D. Rydalch

## Executive Summary

Neutron radiation is currently being used to indicate the presence of special nuclear material. In the maritime environment, detecting special nuclear material has nominally been accomplished through on-board examinations. Testing at the USS Barry is meant to further the development of being able to detect shipboard special nuclear material by off-hull means. MIDN Fletcher D. Rydalch, USN, has been selected as a Trident Scholar for the United States Naval Academy graduating Class of 2015 and the USS Barry Ship-Effect Test is part of his Trident research.

Testing is scheduled to take place from September 2014 through March 2015. USS Barry testing is built around four testing objectives.

***Test Objective 1:*** Collect radiation background data around the USS Barry

***Test Objective 2:*** Analyze collected data to correctly characterize the neutron and gamma radiation backgrounds around the USS Barry in order to characterize and represent the ship effect for the USS Barry

***Test Objective 3:*** Determine the energy spectrum for the background gamma radiation measured around the USS Barry

***Test Objective 4:*** Quantify the impact on detection feasibility for off-hull measurement of SNM signatures based on the characterized background radiation data

To achieve the objectives, two testing scenarios have been developed and planned: 1) dynamic motion testing, and 2) static testing. Extensive collaboration has taken place with Space and Naval Warfare Systems Command (SPAWAR), Pacific Northwest National Lab (PNNL), and the US Navy to obtain capable detection systems. Three systems will be used: 1) a combined NaI and  $^3\text{He}$  detector known as the MPS system, 2) separate NaI and  $^3\text{He}$  detectors known as the MPS modular system, and 3) the MANS detector, a  $^3\text{He}$  detector. Combined, these detectors are to effectively measure and provide the data to spatially characterize the neutron and gamma radiation backgrounds of the USS Barry.

## 1 Purpose

This test plan is meant to give an overview of the characterization of neutron and gamma radiation signatures and to provide all required information to describe and carry out the USS Barry Test. Initial testing is planned from November 3, 2014 – November 20, 2014. This plan will relate how the USS Barry Test will be conducted and what is necessary for it to be considered a success. Testing will be conducted using two different scenarios: static surveys and dynamic surveys. All data collection will be conducted at the Washington Navy Yard.

**Test Objective 1:** Collect radiation background data around the USS Barry

**Test Objective 2:** Analyze collected data to correctly characterize the neutron and gamma radiation backgrounds around the USS Barry in order to characterize and represent the ship effect for the USS Barry

**Test Objective 3:** Determine the energy spectrum for the background gamma radiation measured around the USS Barry

**Test Objective 4:** Quantify the impact on detection feasibility for off-hull measurement of SNM signatures based on the characterized background radiation data

Data collected and recorded during this test will be neutron counts per second (CPS), gamma CPS, gamma spectroscopy, GPS fixes, and spatial orientation. The watercraft that the detectors will be attached to is the Edgewater 5.

### 1.1 System Description

This section lays out the planned physical components that will be used to collect data. The system comprises 5 radiation detectors with their ancillary equipment, two computers, a LASER range finder, boat, trailer, electrical generator, and DC power supply as listed in Table A-1-2. Four of the detectors, the two Modular Systems and two MPS Systems will be daisy chain connected together using the Aggregator and Acquisition and Telemetry Unit (ATU) units. Therefore, data collected (excluding the MANS detector) will be combined and analyzed together throughout the test.

Each detector's specifications were drawn from information provided by SPAWAR.

#### 1.1.1 Modular System <sup>3</sup>He (Modular MPS Manual SPAWAR)

The <sup>3</sup>He Module has one set of three <sup>3</sup>He filled tubes. Each tube is cylindrical in shape with a two inch diameter and a length of three feet. The <sup>3</sup>He tubes feed into a neutron pulse monitoring module made by Precision Data Technologies (PDT), P/N: 20A, which outputs a Transistor-Transistor-Logic (TTL) pulse for each neutron detected. Using multiple tubes increases surface area, enabling the module to detect more neutrons. In addition, the backside (side that faces away from the area of interest) of the module is filled with High Density Polyethylene (HDPE), which acts as a moderator and vastly improves sensitivity to neutrons. The addition of this moderator makes the operation directional; where the flat side of the <sup>3</sup>He tubes faces the area of interest and the moderator faces away from the area of interest. The battery door is located on the moderator side of the module, thus proper orientation of the detector is to face the battery door away from the area of interest. Orientation during this testing will be horizontal, with the sensitive side facing up.

### ***1.1.2 Modular System NaI (Modular MPS Manual, SPAWAR)***

The NaI Module has one 2" x 4" x 16" Sodium Iodide crystal made by Saint Gobain. At the top of the crystal is the Photo-Multiplier Tube (PMT) made by Hamamatsu, which converts the energy from detected gamma rays into an electrical pulse that can be quantified with electronics. The crystal's large surface area enables the module to efficiently detect gamma rays. With more gamma rays being detected at a time, the integration time necessary to get desirable identification statistics is decreased. In addition to every module being shielded from electrical noise, the PMT is shielded from magnetic fields. Properly shielding the PMT eliminates calibration issues introduced from nearby magnetic fields (such as Earth's magnetic field, nearby motors, etc.).

### ***1.1.3 MPS System (2 PODS) [MPS Operators Manual]***

The MPS System includes two identical and independent PODs. These PODs are watertight, EMI-shielded containers, which house gamma and neutron sensors and electronics. Each POD contains two Saint Gobain 2" X 4" X 16" NaI sensors stacked vertically, with their largest surfaces sharing a common plane. High Voltage/Pre-Amp (HV/PA) caps are mounted on the end of each PMT.

Each MPS POD contains two neutron sensor modules, each comprising three 2" X 34" (active area), 3 atm,  $^3\text{He}$  sensor tubes mounted in a linear arrangement in an air-tight manifold, with a high voltage power supply and pulse shaping circuitry contained within the manifold. The two  $^3\text{He}$  modules are mounted on each side of the NaI gamma detectors, in a parallel orientation. Extensive information on these detectors is found in the operator's manual sited in the references, which will be provided in the final report.

### ***1.1.4 MANS Detector (NaI)***

The MANS (Modular Airborne Neutron Sensor) contains four 6" diameter 6-foot long  $^3\text{He}$  tubes. Each neutron sensing tube is pressurized to just above 1 atm. They are surrounded by poly foam and poly sheets. The intrinsic neutron detection efficiency is reported to be close to 30% (exceptionally high) though this efficiency has not been validated. The detectors were originally designed for maximum neutron detection efficiency in a P-3 bomb bay.

### ***1.1.5 The Edgewater 5***

Figure A-1-1 contains the published specifics for the Edgewater craft which will be used in this test. Table A-1-1 shows the design and layout of the boat Edgewater 5.

**Table A-1-1 Specifics for Edgewater Craft**

Length	24'   7.3m	Transom Height	Single-25"   63.5cm
Beam	8'6"   2.6m	Max Power	350hp   260kw
Draft (Boat Only)	13"   33cm	Cockpit Depth	19"   48.3cm
Boat Weight (approx.)	2700lbs   1225kg	Cockpit Area	79sq.ft.   7.34m <sup>2</sup>
Weight Capacity	3000lbs   1360kg	Approx. Length Boat/Trailer	32'   9.75m
Person Capacity	8	Bridge Clearance w/out Top	5'2"   1.6m
Person Weight	1200lbs   544kg	Bridge Clearance w/T-Top	7'10"   2.4m
Fuel Capacity	70gal   264L	Bridge Clearance w/Upper Station	9'2"   2.8m
		Foam Floatation	Unsinkable/Level

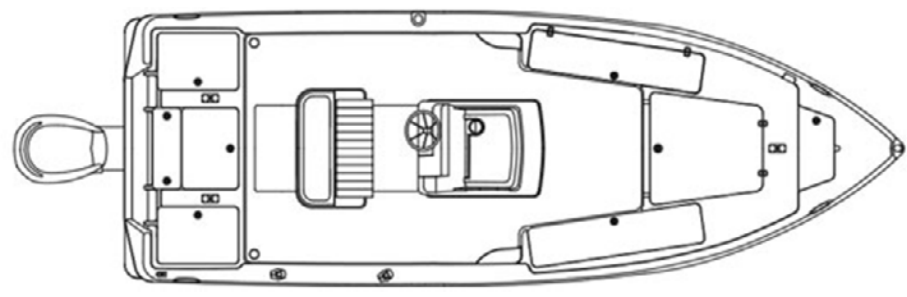

**Figure A-1-1 Edgewater Craft**

The boat layout with the detectors is depicted in Figure A-1-2. This figure shows how the systems are integrated together as well as the connections between the systems.

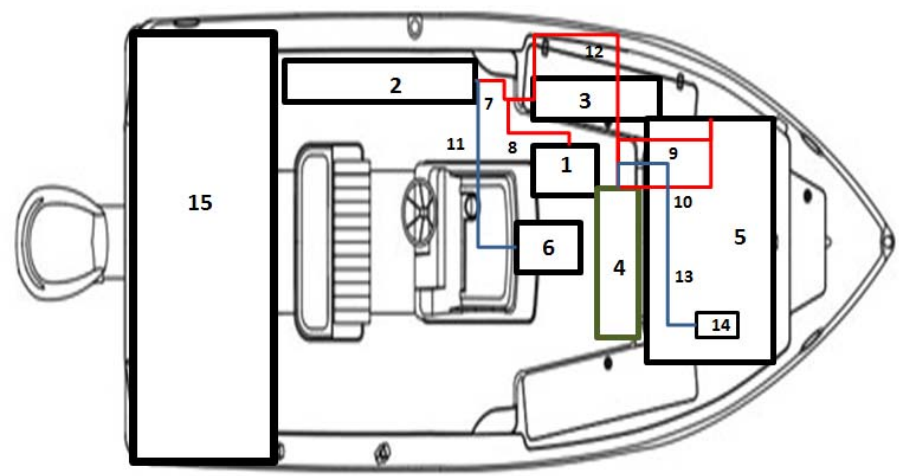

**Figure A-1-2 Edgewater 5 with depicted detectors and connections**

**Table A-1-2 Devices and brief description of role in the testing layout**

1) The Aggregator	<ul style="list-style-type: none"> <li>Modular MPS Hub that receives data from detectors</li> </ul>
2) $^3\text{He}$ Detector (Modular System Detector)	<ul style="list-style-type: none"> <li>Used to provide neutron detection signal</li> <li>Daisy chain connected (7) to NaI detector (3)</li> </ul>
3) NaI Detector (Modular System Detector)	<ul style="list-style-type: none"> <li>Used to count gamma radiation</li> <li>Daisy chain connected using male to female connection (8) to aggregator (1).</li> <li>Receives the Ethernet cord (12) coming from the ATU (4) in order to include the data received on the aggregator</li> </ul>
4) Acquisition and Telemetry Unit (ATU)	<ul style="list-style-type: none"> <li>Data processor for data received from the MPS systems (5)</li> <li>Ethernet cord (12) connects ATU to <math>^3\text{He}</math> detector (2). Connection allows for data from MPS detectors (5) to be included in the aggregator's (1) count data.</li> </ul>
5) MPS System Detectors (There are two of them stacked on top of each other).	<ul style="list-style-type: none"> <li>Data is transmitted through cord (10, 9) to ATU (4)</li> </ul>
6) Computer	<ul style="list-style-type: none"> <li>Receives data through Ethernet cord (11). The cord is shown connected to the <math>^3\text{He}</math> detector (2), but it does not necessarily have to be connected there. It may be plugged into the NaI detector (3) or the Aggregator (1). Aggregator Ethernet connection may be faulty</li> </ul>
7) Male to Female Cord	-
8) Male to Female Cord	-
9) Female to Female Cord (Long)	-
10) Female to Female Cord (Long)	-
11) Ethernet Cord	-
12) Ethernet to 5 prong male connector.	<ul style="list-style-type: none"> <li>Plugs into ATU (4)</li> </ul>
13) GPS goes from ATU (4) to top of MPS System Detectors (5).	-
14) GPS	-
15) MANS Detector	<ul style="list-style-type: none"> <li>Has own set of chords, computer, and multi-channel analyzer</li> </ul>

## **2 Operations**

### **2.1 System Operation**

#### **2.1.1 Off Hull Detection Operations**

System operation will be conducted by MIDN Rydalch and Trident advisors when available. The MANS detector will be used extensively during dwell counts (stationary). The other detection systems will be operated continuously, with data recorded concurrently with the MANS detector for dwell counts.

### **2.2 Support and Maintenance**

#### **2.2.1 Support**

The Naval Station, located in Annapolis, MD, has provided one of their assigned 2<sup>nd</sup> Class Petty Officers to drive and manage the Edgewater. BM2 Ryan Blakemore will be the one responsible for driving the trailer with the boat to the Navy Yard for the test. He is also the primary driver for the boat on the water.

Extensive collaboration has taken place with Space and Naval Warfare Systems Command (SPAWAR), Pacific Northwest National Lab (PNNL), the Defense Threat Reduction Agency and the US Navy to obtain capable detection systems. Technical support is provided directly through communication with SPAWAR when needed.

The Washington Navy Yard has agreed to store the Edgewater 5 between detection days in Washington DC. They also have agreed to protect the boat and the detectors as they are stored at the Washington Navy Yard overnight. The boat will be docked in a slip near the USS Barry.

#### **2.2.2 Maintenance**

Detector calibration for the gamma sensors is automatically conducted. A baseline background will be collected each day before surveys are conducted near the USS Barry. No additional maintenance is anticipated during the testing.

### **2.3 Go/No Go Criteria**

The optimal detection scenario involves all the detectors working together. Ideally all 5 detectors will function. Functioning includes each detector turning on, sensing data, logging data, and allowing the opportunity for data to be retrieved. If a device cannot function it will be deemed unusable.

- Both the modular system and the MPS system must be deemed usable for the test to continue. Therefore, once on, they have to communicate with the computer and the data file covering a five minute span will be taken and reviewed. Currently the detectors measure about 2-4 neutron cps, and approximately 400 gamma cps in open area. Therefore, if those numbers can be reproduced then the systems are usable.
- The MANS detector is separate from both the modular system and the MPS system. The project will not be stopped if the MANS cannot be deemed usable.
- If the modular system and the MPS system are usable the USS Barry testing will follow. If one of the MPS systems is not useable, MIDN Rydalch will consult with his Trident advisers on the best recovery path.

### 3 Overall Test Approach

Testing is planned to be near the Washington Navy Yard (WNY) in Washington DC. Docking of the Edgewater will be near the USS Barry in the WNY's boat slip that runs parallel to Parsons Ave. The boat will be taking by trailer to the marina at the Joint Base Anacostia, where it will be launched and taken to WNY.

#### 3.1 Test Schedule

**Table A-3-1 Overview of test schedule and milestones**

Event	Start	End
Dry Run/Land Testing	9/20/14	10/29/14
Water Testing	10/1/14	10/29/14
Test Run at USNA	10/30/14	10/30/14
Test Run Results Analysis	10/30/14	11/1/14
USS Barry Testing	11/4/14	11/20/14
Future Testing	1/5/2015	3/1/2015

#### 3.2 Test Design Overview

The USS Barry testing design includes two different testing scenarios. This first is dynamic motion data collection. The second is static motion data collection.

##### 3.2.1 Dynamic Motion

Dynamic motion data collection is the process of collecting data while in constant motion. Figure A-3-1 depicts how this is to be conducted.

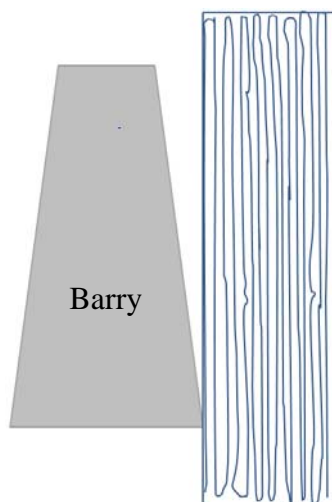
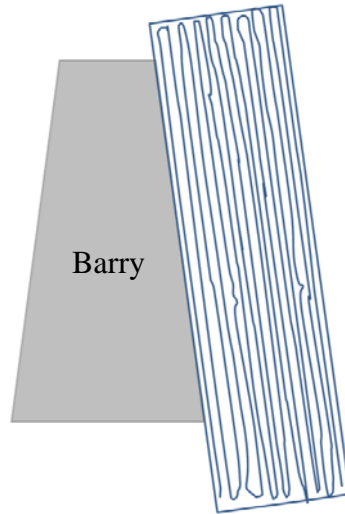

**Figure A-3-1 Dynamic motion path and restraints**

The path requirements are that the data are nominally taken to be in a contiguous rectangular area; it is not detrimental if data are taken outside of the area, but this will make the data interpretation for the contour plots more difficult.



One route that could also yield results is including the LASER range finder and maintaining a constant distance from the hull with each pass. This route is depicted in Figure A-3-2.



**Figure A-3-2 Possible data collection route**

Figure A-3-3 depicts the current location of the USS Barry, depicting how the USS Barry is moored to the pier and accessible.

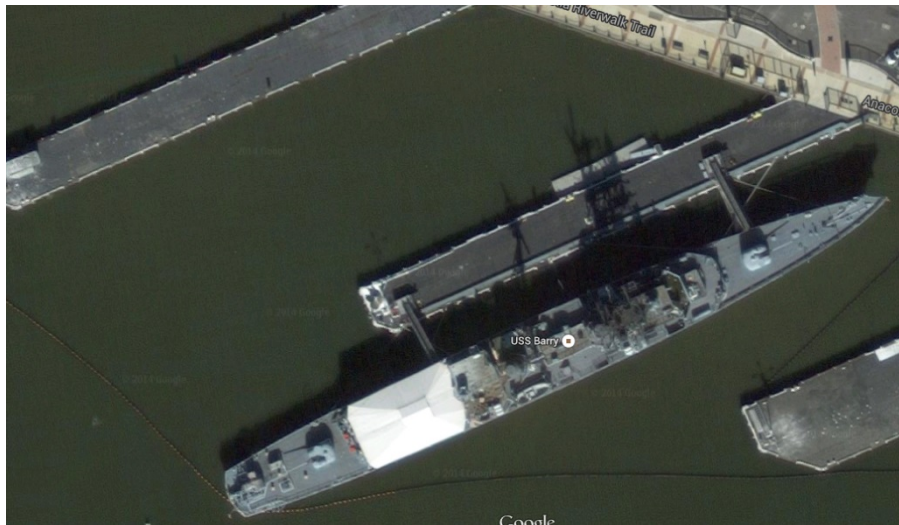

**Figure A-3-3 Current docking status of the USS Barry**

Figure A-3-4 shows the dynamic path for collecting data around the USS Barry.



**Figure A-3-4 Current docking of USS Barry with notional dynamic motion path**

As the test is planned, there is not an exact distance that the data collection will cover. Initial planning and testing suggests that the surveyed area should stretch at least 100 feet from the ship; therefore, testing scenarios plan for that. But the reality of the situation and the project is that the exact distance that the ship effect will be measured to is not known. It may reach as far as 250 ft. To account for varying distances, initial background measurements will be taken at 500ft, 400ft, 300ft, 200ft, and 100ft from the center of the hull. These will show the difference measure ship effect at that point of the ship. Once no statistically significant variation is found then the survey area will cover to that distance.

### **3.2.2 Static Collection**

The process of determining an actual increase of radiation received is a result in the number of detected counts above a base value of background counts. Therefore, a higher number of counts received may lead to more useful data. For radiation detection the higher number of counts received decreases the likelihood of being able to detect special material by masking a change. The static collection scenario provides a way to characterize the ship effect at greater accuracy due to the statistical nature of radiation. Therefore, instead of counts per second, the static collection will result in measuring counts per five minutes (300 seconds) or per ten minutes if test schedule allows. During these static data collection periods, the boat will be held stationary with either an anchor or with lines attached to the Barry and the adjacent pier. Distance from the Barry will be measured with the LASER distance measurer and GPS coordinates will be recorded.

Figure A-3-5 depicts the static collection points. On the figure the space between the docks is about 100 feet. The USS Barry's specifications are as follows; beam: 45 feet (13.72 meters), length: 418.5 feet (127.56 meters), draught: 19.5 feet (5.94 meters), displacement: 4,050 tons ([www.militaryfactory.com](http://www.militaryfactory.com)).



**Figure A-3-5 Notional path of static collection**

In testing and dry runs at the United States Naval Academy, neutron radiation measurements were generally between 3 cps and 5 cps on the open water. Since radiation background on open water is expected to be common, the determination for the static positioning and fix requirements were determined based on data collected in the Severn River. In order to have statistically sound data it is preferred to record above 1000 neutron counts. For open water surveys to reach 1000 counts requires that the detector be sensing for more than 125 seconds. Therefore, to produce a statistically significant result the detection time in each dwell will be 5 minutes, or 10 minutes if time allows. Each dwell will be 15 feet apart from the other dwell points. The area that will be surveyed (depicted by the white circles) is about 50 feet by 420 feet. With each dwell being 15 feet apart from the others, this will require 84 dwell counts, for a grand total of 420 minutes of data collection, or 840 minutes with 10 minute counts. Some dwell locations may be eliminated if it is determined that these are not necessary to the characterization.

### 3.2.3 Test Objective and Scenario Correlation

Dynamic motion and static detection will both contribute to meeting the test objectives. Table A-3-2 shows the test objectives and to which objective each testing scenario will contribute.

**Table A-3-2 Test Objectives and Scenario Correlation**

Test Objective \ Test Scenario		1	2
		Static	Dynamic
1	Collect useful data around the USS Barry	X	X
2	Analyze collected data to correctly characterize the neutron and gamma radiation backgrounds around the USS Barry to correctly characterize and represent the ship effect for the USS Barry in counts received	X	X
3	Determine an energy spectrum from the gamma radiation received around the USS Barry	X	X
4	Quantify the effect of the characterized background radiation on SNM detection feasibility in an off-hull scenario	X	X

## 4 Data Management

### 4.1 Data Logging and Recovery

Each detector is equipped to gather and record data. The Modular MPS system and the MPS system will be combined to log data together. The MANS detection data will be recorded separately and manually.

The modular system plugs into the computer via an Ethernet cable from either the Modular MPS NaI detector or the  $^3\text{He}$  detector. The detectors are connected together with the end piece being the aggregator. Having them connected together with the aggregator results in the counts received being combined so that the systems can work as a larger more capable detector.

The MPS system can also be connected into the daisy chain by Ethernet connection from the ATU to either the NaI detector or the  $^3\text{He}$  detector. In theory, the aggregator Ethernet port should also work as a gateway to the combined system response, but the connection has not been as reliable, so the other connections in the NaI and  $^3\text{He}$  detectors will be used.

On the data collection computer there are multiple logging programs for these two systems. The main program to be used is RaptorX. RaptorX's owner manual describes the basics of RaptorX as a Microsoft Windows-based command and control center. Authorized users anywhere in the world can share a real-time Geographic Information System (GIS) driven interface to control or track devices and to share device data with other RaptorX users. GIS is any system that captures, stores, analyzes and presents data that are linked to location.

All data and events from the user's remote devices are logged and stored for immediate or delayed analysis. User-selectable Devices displaying events, alarms and communication information can be assigned to specific locations anywhere on the three dimensional map of the Earth.

RaptorX is essentially a 3D Geo-browser, meaning a highly intuitive and engaging three-dimensional visualization, graphic-user-interfaces (GUI). This technology enables access to vast archives of GIS data from a network-centric perspective.

RaptorX can operate as a standalone control center, or as part of a network. Security settings allow the user to share devices and data with specific partners, or to hide them from the rest of the RaptorX community.

Despite the power and sophistication of RaptorX, the user interface is simple and intuitive. The 3D Globe is always visible in the main screen, with tools and controls organized in tabs and panels that can be opened when needed. Devices can be placed on the map with the mouse or touchpad.

Everything that occurs during a RaptorX session can be saved as a Project file. Projects can be reopened and played back, and can be copied or moved to other PCs for further analysis.

RaptorX is a powerful yet easy-to-use tool for the management of device and sensor assets, providing real-time, real-world data for tactical decision makers. It is open-architecture, government-owned software requiring no licensing, no fees and no tracking.

One of its great strengths is that it is designed to be customized to meet the needs of a specific program, mission or even a specific user. Plug-ins and extensions designed by 3rd parties are not only allowed but are expected and accommodated” (RaptorX, Owner Manual).

For the Modular MPS system there has been a plug-in written and will be used as an interface with the MPS and Modular MPS systems. The steps for turning on, booting up, and running RaptorX are as follows:

- Opening RaptorX
  - Click the icon on the desktop to open RaptorX
  - Select “create new” to create a new file, unless you want to continue the prior logging file
  - Select the Recon Element
  - At this point, the MPS system should automatically populate the logging screen
    - With the MPS system plugged via the modular system, the logging information will be counting the MPS systems, NaI detector, and <sup>3</sup>He detector
- Running RaptorX
  - To see the modular systems separate logging the modular system can be opened and viewed by clicking the connections icon on the home screen, select add, select ModAggregator plug in, the IP address is 192.168.0.109, the port is 5002.
  - Select connect, and the map will populate with the three different modular system icons which can then be selected and viewed separately.
  - Each connection in the modular system is concurrently logging its own data stream; the NaI and <sup>3</sup>He are separate but the Aggregator combines the two.
  - The MPS system stamped files have all four detectors logged together with MPS attached GPS position. Files are saved in either a “.csv” or a “.n42” format.
- Data Recovery
  - Right click the icon on the map
  - Select the correct exporting file type
  - Select export
  - Exports file as a comma separated variable (csv) file
  - Give it a unique name
- Data Recover (2)
  - The MPS File Downloader is a plug in that logs RaptorX tracked events and saves them as an .n42 file. These files are automatically being kept and are recoverable.
  - On the desktop, click the MPS File Downloader icon and select the files you wish to download.
  - Downloaded files are then saved in MPS File Downloader file on the desktop
  - The purpose of this file is to open the data acquisition set in PeakEasy
  - PeakEasy can analyze certain time periods of the overall detection time
  - PeakEasy is also used to shows the energy spectrum for detected gamma rays

For the USS Barry testing, the csv recovered files and the PeakEasy displays will be most used. The csv files will be loaded into a MATLAB script and coded so that it can produce a contour plot indicative of the fluctuations of background neutron and gamma radiation levels. These will be on a count per second basis. PeakEasy will use the recorded .n42 files to show the measured energy spectrum for the data collected.

## 5 Other Significant Information

### 5.1 Training

There will be different training events that will lead up to testing and official data collection.

#### 5.1.1 Boating Safety Course

In order to be granted use of the Edgewater 5 from the Annapolis Naval Station, MIDN Fletcher Rydalch completed a State Approved Basic Course. This was arranged by MIDN Rydalch and completed in accordance with United States Coast Guard direction.

#### 5.1.2 Detection System Training

Mr. Nathan Paradis, SPAWAR, visited the United States Naval Academy on Tuesday, September 9, 2014. This training was the first official training for MIDN Fletcher Rydalch with both the MPS systems and the modular systems. Training and troubleshooting lasted the entire workday.

### 5.2 Logistics and Timeline

Pre-testing and system verification was completed by November 3, 2014. Following the completion of testing and evaluation, transportation to the Washington Navy Yard from Annapolis, Maryland took place on November 4, 2014.

A time line of the events leading up to the being able to begin collecting data is found in Table A-5-1. These events were made through coordination with LT Scott Neidhold, USN, Washington Navy Yard, and LT Chris Perry, Annapolis Waterfront Readiness.

**Table A-5-1 Timeline of move from the Naval Academy to the Washington Navy Yard**

Date / Time	Event
November 3	
1200	BM2 Blackmore leads out in the transportation of the Edgewater 5 from Santee Basin to the Naval Station to load in a trailer.
November 4	
1155	Meet at Naval Station, Annapolis
1300	Arrive at 928 Giovonalli Way, Washington DC
1330	Put boat into water to drive up to USS Barry, and the slip near by
1400	Situate and stow Edgewater in slip by USS Barry
1500	Return to Annapolis

Each following data collection day will have some variation due to project and testing development. Nominally, the testing days will be as shown in.

**Table A-5-2 Planned testing days**

Date	Time Starting
November 6, 2014	0900
November 12, 2014	1000
November 13, 2014	0900
November 18, 2014	0900
November 20, 2014	0900

### **5.3 Test-Day Checklist**

Table A-5-3 will be used will be used to prepare for each testing day. This sheet will provide information to ensure safety during the USS Barry test. It also will maintain accountability for every object used for data collection and analysis. For each testing day this sheet will be printed and logged.



**Table A-5-3 Pre-test Checklist**

Task/Part/Information	
Humidity (%)	
Precipitation Chances (%)	
Tide Level (m/ft)	
Temperature (°C/°F)	
Wind (mph)	
Detectors Battery Level	
NaI Battery (1-5)	
<sup>3</sup> He Battery (1-5)	
ATU Battery (2) (1-10)	
The Aggregator Battery (2) (1-10)	
Main Computer Battery Level	
MANS Computer Battery Level	
Parts Inventory	
Computer	
Computer Charger	
Ethernet Cable	
NaI Detector	
Short Male to Female Connecting Cable (2)	
<sup>3</sup> He Detector	
The Aggregator	
Network to 5 Prong Cable	
ATU	
Long-Female to Female Connecting Cable (2)	
MPS GPS	
LASER Range Finder	
Inverter	
Generator	
MANS Detector	
Signal Cable	
Power Cable	
MANS MCA	
MANS Computer	
MANS Power Supply	

## Bibliography

- C. S. Blessinge, R. L. (November 2006). *Neutron Detection Algorithm Development*. Oak Ridge National Laboratory, Nuclear Science and Technology Division. Retrieved April 20, 2015, from <http://web.ornl.gov/~webworks/cpppr/y2007/rpt/125365.pdf>
- Cook, B. (2014, February 3). *Gone Fission: MSC ships test radiation detection*. Retrieved from [msc.navy.mil: http://www.msc.navy.mil/sealift/2004/March/radiation.htm](http://www.msc.navy.mil/sealift/2004/March/radiation.htm)
- Dhs. (2002). *Maritime Security Strategy*. Retrieved January 2014, from [http://www.dhs.gov/xlibrary/assets/HSPD13\\_MaritimeSecurityStrategy.pdf](http://www.dhs.gov/xlibrary/assets/HSPD13_MaritimeSecurityStrategy.pdf), 2002
- EPA. (n.d.). The Atomic Energy Act of 1954., (p. Section 2 item e. Page 10 of Act). Retrieved January 11, 2014, from <http://www.epw.senate.gov/atomic54.pdf>
- Estanislao Aguayo, R. T.-2. (2013). *Ship Effect Neutron Measurements and Impacts on Low-Background Experiments*. PNNL-22953.
- Farlex. (2015, April 20). *The Free Dictionary*. Retrieved from <http://medical-dictionary.thefreedictionary.com/normal+distribution>
- Gary W. Phillips, D. J. (2005, July). *A Primer on the Detection of Nuclear and Radiological Weapons*, Gary W. Phillips, David J. Nagel, and Timothy Coffey, Center for Technology and National Security Policy, National Defense University. Center for Technology and National Security Policy, National Defense University.
- Geelhood, D. B. (2014, January). Personal communication with Dr. Bruce Geelhood. Oak Ridge, TN.
- Glenn F. Knoll, W. (2000). *Radiation detection and Measurement. 3rd Edition*.
- Goorley, J. (2013). Initial MCNP6 Release Overview - MCNP6 version 1.0. *LA-UR-13-22934*.
- IAEA. (2013, August). *Incident and Trafficking Database*. Retrieved from <http://www-ns.iaea.org/security/itdb.asp>,
- IAEA Safeguards Glossary. (2001). Retrieved January 2014, from [http://www-pub.iaea.org/MTCD/publications/PDF/nvs-3-cd/PDF/NVS3\\_prn.pdf](http://www-pub.iaea.org/MTCD/publications/PDF/nvs-3-cd/PDF/NVS3_prn.pdf)
- John D. Dirk, M. E. (December 2003). *Terrestrial Thermal Neutrons, IEEE Transactions on Nuclear Science, Vol. 50*.
- John Dirk, J. Z. (2003). *Investigation into Ambient Thermal Neutron Flux*. Annapolis: Trident Research Project Report.
- Justin C. Langan, M. J. (October 7, 2009). *Evaluation of Aerial Radiation Detection Identification and Mapping System (ARKIMS) For Detection of Neutron Sources*. Fort Belvoir, VA: Defense Threat Reduction Agency.
- Kouzes, R. T., Ely, J. H., Seifert, A., Siciliano, E. R., Weier, D. R., Windsor, L. K., . . . Buc. (2008). *Cosmic-ray-induced ship-effect neutron measurements and implications for cargo scanning at borders*. Richland, WA: Pacific Northwest National Laboratory.
- Mewaldt, R. A. (n.d.). *Cosmic Rays*. California Institute of Technology. Retrieved January 2014, from [http://www.srl.caltech.edu/personnel/dick/cos\\_encyc.html](http://www.srl.caltech.edu/personnel/dick/cos_encyc.html)
- NOAA. (n.d.). *Ocean Service*. Retrieved February 4, 2014, from NOAA: [oceanservice.noaa.gov/facts/shorelength.html](http://oceanservice.noaa.gov/facts/shorelength.html)
- R. C. Baumann, T. Z. (1995). *Boron compounds as a dominant source of alpha particles in semiconductor devices*. Las Vegas, NV: Proc. 33rd Annu. IEEE IRPS.
- SPAWAR, N. P. (2013). *Modular MPS Manual*. SPAWAR.
- Strategy, U. N. (n.d.). *White House*. Retrieved January 2014, from [http://www.whitehouse.gov/sites/default/files/rss\\_viewer/national\\_security\\_strategy.pdf](http://www.whitehouse.gov/sites/default/files/rss_viewer/national_security_strategy.pdf), May 2010

- Systems, T. o. (2014, February 3). *nist.gov*. Retrieved from <http://www.nist.gov/pml/div682/grp04/radiation-detection.cfm>,
- V.D. Scott, P. J. (2009). *Investigation of the “Ship Effect” in Off-Shore Screening for Nuclear WMD*. Senior Design Project Report.
- WMD, H.-t. n. (2014, February 3). *PNNL.gov*. Retrieved from <http://www.pnnl.gov/news/release.aspx?id=405>