

# Subarray Beamforming for Reducing the Effect of Flow Noise on Sonar Arrays

James Leader (1), Chaoying Bao (2) and Jie Pan (1)

(1) School of Mechanical and Chemical Engineering, University of Western Australia, Australia

(2) Defence Science and Technology Organisation, Australia

## ABSTRACT

Subarray beamforming has been identified as a signal processing technique to potentially reduce the effect of aerodynamically induced flow noise against a target signal which is difficult to target with full array beamforming due to its near-field and non-stationary nature. Previously the technique had been proposed yet was not fully investigated nor adequately compared to its full array adaptive counterpart. In this study the nature of flow noise and its implications to the effectiveness of the subarray technique have been investigated through an idealised mathematical model. The result demonstrates the potential to achieve considerable array gains against traditional adaptive beamforming, heavily dependent on flow noise characteristics, and the choice of subarray configuration is justified by a trade-off in faster adaptation times against the accuracy of the cross-spectral matrix estimate.

## INTRODUCTION

Flow noise is currently considered to be the limiting performance factor for sonar systems on submarines, ships and towed arrays as recent advances in ship silencing technology have mainly targeted machinery and propeller noise thus leaving the effect more prominent. Musha and Kikuchi (2005) originally proposed the use of a subarray method to target near field flow noise, and showed a successful performance benefit over conventional beamforming under the field testing of what was described to be a very quiet ship. Their study utilized an acoustic holography technique to isolate flow noise sources around a planar array; however an inadequacy in their paper is the lack of comparison to full array adaptive beamforming which is the current state of the art to many military submarines, and an understanding of the mechanisms involved to best exploit the optimal subarray configuration.

The implementation of subarray beamforming as dual stage array signal processing is not new, yet has existed in a form with the objective of reducing the computational complexity associated with adaptive beamforming (Nuttall & Willett 1993). On the contrary, the algorithms that have been shown most effective at targeting flow noise are first stage adaptive and are therefore far more computationally intensive than full array adaptive beamforming. Lee et al. (2004) considered subarray beam-space adaptive beamforming applied to a dynamic towed array in order to recover signal loss under significant manoeuvring, but did not consider specifically the effect of flow noise. Cox and Lai (2004) also investigated subarray beamforming to improve the performance of a long line array, but considered first stage conventional beamforming rather than the first stage adaptive configurations that have best been attributed to reducing the effect of flow noise by our previous work using a point source model of flow noise (Bao et al. 2010).

A model that can adequately simulate flow noise samples in ideal conditions at different array and flow configurations is highly desirable in order to optimise the subarray technique in its pure form, and forming such a model is central to our work. For example, the effectiveness of applying subarray

beamforming to a sparse array is of particular interest for improved efficiency in the presence of fewer sensor elements.

## Subarray Beamforming

Adaptive beamforming (ABF) typically achieves a greater degree of spatial selectivity than its conventional counterpart by an algorithm such as Minimum Variance Distortionless Response (MVDR) which calculates optimum weights to reject interference sources. Frequency domain beamforming is necessary to categorise the target in a military application, and as such there is required a finite sampling time in order to build samples (called beamforming snapshots – each composed of the number of time domain samples required for one FFT period). The propagation delays  $\tau$  corresponding to sensor locations  $\mathbf{d}$  and look direction  $\theta$  are given by equation (1), and the appropriate steering vector  $\mathbf{v}$  by equation (2), where  $\theta$  assumes the discrete values of  $\beta_1$  or  $\beta_2$  corresponding to the stage of beamforming. The first stage steering vector must be taken with an origin at the centre of the subarray, with the second stage steering vector with respect to the sensors physical location in the global coordinate system (figure 1).

$$\tau(\theta) = \mathbf{d} \sin(\theta)/c \quad (1)$$

$$\mathbf{v}(\theta) = e^{-2\pi j f \tau(\theta)} \quad (2)$$

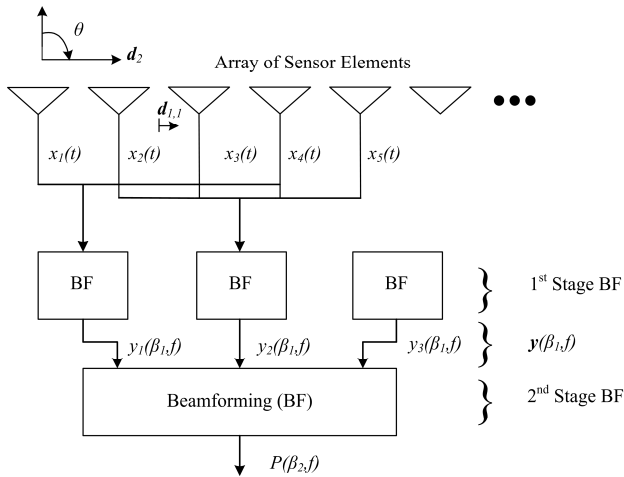
The formula for the MVDR algorithm is given below in equation (3), derived from minimising signal power while keeping the response in the look direction equal to conventional delay and sum beamforming (CBF).  $\mathbf{R}$  is the cross spectral matrix (CSM) estimate,  $\mathbf{v}$  is the steering vector, and  $^H$  represents the Hermitian transpose. These snapshots are averaged to compile  $\mathbf{R}$  given by equation (4) where  $\mathbf{x}$  is the frequency domain sensor outputs.

$$\mathbf{w}_{opt} = (\mathbf{R}^{-1} \mathbf{v}) / (\mathbf{v}^H \mathbf{R}^{-1} \mathbf{v}) \quad (3)$$

$$\mathbf{R} = E\{\mathbf{x} \mathbf{x}^H\} \quad (4)$$

It has been envisioned that the smaller subarrays may improve sonar performance under the non-stationary nature of flow noise as they allow for faster adaptation times since less

snapshots are required to build the non-singular  $\mathbf{R}$ . However, the trade off in CSM accuracy through the number of samples composing the expected value must also be considered, as must the reduction in the effective array aperture.



**Figure 1.** Subarray beamforming schematic

The second stage beams,  $\beta_2$  (figure 1), represent the desired output look direction bearings, and the first stage beams,  $\beta_1$ , must be a subdivision of this desired resolution/beamwidth. Each of the first stage beams have an associated signal value  $y(f, \theta)$  corresponding to the output of the first stage over a number of beamforming snapshots that is the sum of the sensor outputs with their own optimal weightings (equation 5).

$$y(f, \theta) = \mathbf{v}(\theta)^H \mathbf{A} \mathbf{x}(f) = \mathbf{w}(\theta)^H \mathbf{x}(f) \quad (5)$$

To prevent spatial aliasing we choose the subarray configuration of maximum overlap on our uniform linear array. The second stage of beamforming repeats the process with first stage outputs as inputs, and can calculate second stage weightings or simply use CBF (the major difference in the second stage beamforming is that the *input* signal  $\mathbf{y}(\beta_{1,i}, f)$  is now also a function of the look direction, and in our study two adjacent look directions will share the same first stage weightings). These two configurations are named adaptive-adaptive (ABF-ABF) and adaptive-conventional (ABF-CBF) respectively, and will be compared against both ABF and CBF in this study. For a comparison to CBF-ABF the reader is referred to Bao et al. 2010.

## Flow Noise

Flow noise is defined as the fluctuating pressure field created by hydrodynamic flow in the turbulent boundary layer. The presence of flow noise is unavoidable in submarine operation as laminar flow conditions cannot be maintained, not even at low speeds as the flow is disturbed by torpedo hatches and other irregularities. The spectrum of the noise is low frequency and broadband as are the operating frequencies of passive sonar.

The Navier-Stokes equations are widely believed to describe the motion of a fluid completely, including turbulence, and upon rearranging for incompressible flow the pressure can be given by the following Poisson equation (equation 6) from the divergence of momentum equation.

$$\partial^2 p / \partial x_i^2 = -\partial^2 (\rho v_i v_j - \langle \rho v_i v_j \rangle) / \partial x_i^2 \quad (6)$$

Unfortunately there exists no closed form solution, and the integral solution implies that the pressure is a contribution of the velocity at all points in the flow. Computational Fluid Dynamics (CFD) can discretise the Navier-Stokes equations, but closure with a turbulence model is inaccurate for the fluctuating component of pressure in the turbulent boundary layer (TBL), and using a Large Eddy Simulation model which filters out the insignificant scales of turbulence has been reported to be outside the computational domain for predicting TBL of Reynolds numbers greater than 3200 (Peltier & Hambric 2007). In far-field sound prediction applications many authors choose to use a solution to the Lighthill Analogy (Lighthill 1952) such as the Ffowcs Williams-Hawkins solution (1963) and have been readily verified against experimental results. The Lighthill equation (equation 7) is another rearrangement of the Navier-Stokes equations which introduces an approximation whereby the propagations are taken with respect to a medium at rest. Therefore the assumption is made of no back reaction of the flow onto acoustic waves, which is quite accurate since the acoustic perturbations are much smaller of magnitude than the fluctuations in the flow. It is essential to decouple the fluid dynamics and acoustic components on separate meshes to prevent the accumulation of numerical errors that accumulate thus making a wave highly distorted after travelling no more than a few wavelengths (Wagner et al. 2007). One problem is that use of any solution to Lighthill's equation depends on detailed knowledge of the Lighthill stress tensor  $T_{ij}$  which is a complicated problem of fluid dynamics and dependant on both the geometry in question and flow conditions.

$$[\partial^2 / \partial t^2 - c_{ij}^2 \Delta^2] \rho = \partial^2 T_{ij} / (\partial x_i \partial x_j) \quad (7)$$

Near-field prediction of sound in the TBL is much more tedious both experimentally and numerically due to the unambiguity of source terms. Empirical models exist to provide curve fitting to scaled measured data sets to find approximate the flow noise intensity, spectra and cross spectra – the most widely implemented of these is the Corcos model (1964). In our study, we are most interested in the completely idealised case of flow noise for a more fundamental proof to the effectiveness of subarray beamforming, which may later be verified experimentally with the appropriate array configuration and flow properties. As such, a model built on the original acoustic analogy as a point source model has been implemented to generate sampled data. In this paper a more accurate quadrupole model compared to the simple monopole model in Bao et al. 2010 is provided, yielding similar results to the effectiveness of subarray beamforming.

## FLOW NOISE MODEL

The Lighthill equation is also useful as a dimensional relationship, and the double derivative on the right-hand side of the equation places one quadrupole in each average eddy volume due to the shearing of the fluid alone, neglecting the effect of solid boundaries (Lighthill 1952). These eddies are well correlated blobs of fluid in motion with a random phase compared to other eddies - persistent vortices caused for example by separation of the fluid passing over a bluff body. By assuming a regular pattern in the unsteady flow over the array it is possible to form an easy to implement model as a stream of moving quadrupoles of random phase. The random phase of the emissions should be adequate to simulate the chaotic nature of the flow noise and the convective characteristics of dominant vortices. Each quadrupole is given by four closely spaced and appropriately phased monopoles, which from the solution of the wave equation can calculate the pressure contributions at each sensor element (equation 8, 9, 10)

where  $q$  is the sinusoidal function of source strength (mass outflux) for a simple monopole,  $V_x$  is the velocity of the source in the direction parallel to the receiver, and all other symbols have their usual meanings. The formula has been derived from Morse and Ingard (1986).

$$p(r, t) = \frac{(1 - \frac{1}{c} \frac{dR}{dt})q'(t - \frac{R}{c})}{4\pi R_1} - \frac{q(t - \frac{R}{c})}{4\pi R_1^2} \quad (8)$$

$$R_1 = \sqrt{(x - V_x t)^2 + (1 - M^2)(z - z_s)^2} \quad (9)$$

$$q'(t - \frac{R}{c}) = \frac{dq(\tau)}{d\tau} \Big|_{\tau = t - \frac{R}{c}} \quad (10)$$

We also add independent identically distributed (IID) noise to the model for the purpose of simulating electrical sensor noise and other uncertainties.

**OPTIMAL SUBARRAY BEAMFORMING**

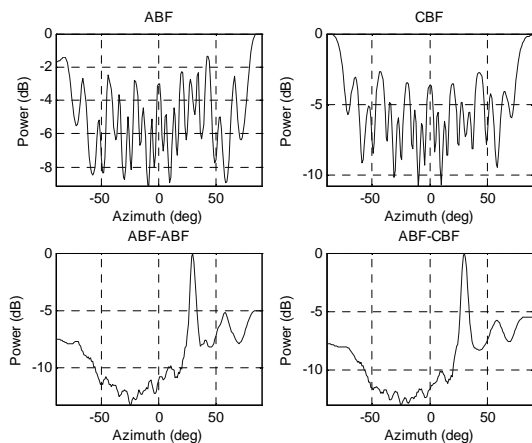
**Parametric Study**

To demonstrate and optimize beamforming configurations in the presence of flow noise (as represented by the moving quadrupole model) a general scenario involving a 64 element uniform linear array (ULA) forms the basis of this study. The spacing between sensor elements is  $d = 0.75$  m and the speed of sound in water is assumed fixed at  $c = 1500$  m/s. Criteria to evaluate the performance of different beamforming configurations will include the array gain and the half power beam width. The signal to noise ratio (SNR) is considered in the look direction of the target signal, and so the array gain, although a useful parameter, does not give an indication of the bearing resolution which is typically greatly improved by adaptive algorithms.

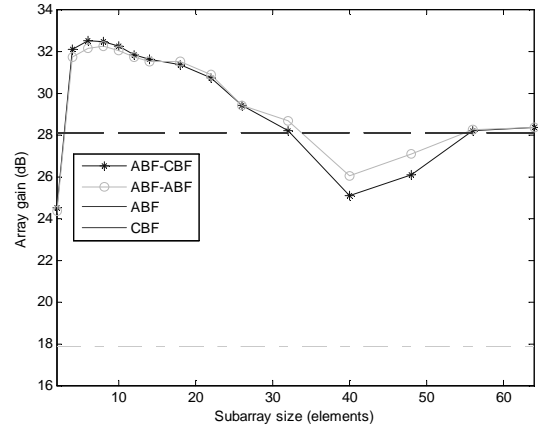
To measure the effectiveness of the subarray technique we consider the array gain (AG) to be most important parameter (equation 11).

$$AG = 10 \log_{10}(SNR_{array}/SNR_{element}) \quad (11)$$

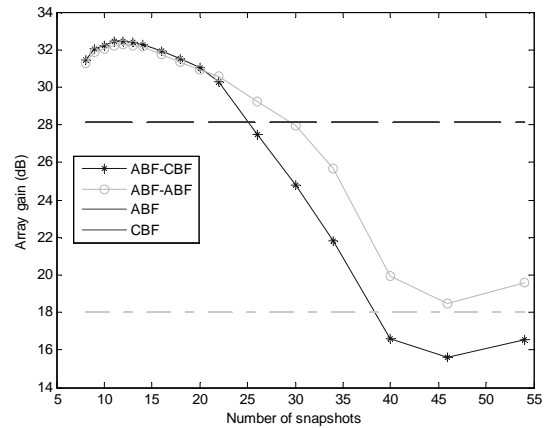
A 64 element uniform linear array is the focus of the study. The optimal configuration is found to be of subarray size 8 and 12 snapshots. The 30° signal stands out against the flow



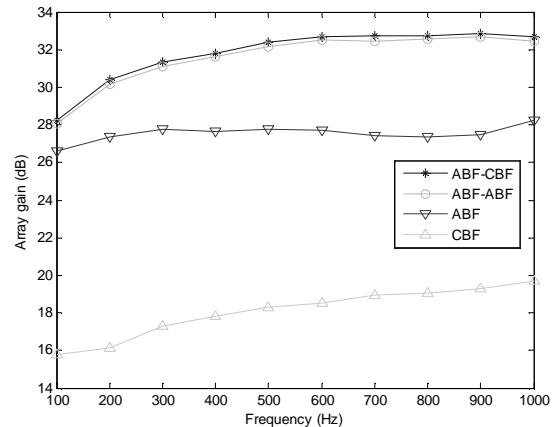
**Figure 2.** Instantaneous beamformer response comparison under flow noise for the weak 30° target signal



**Figure 3.** Full optimisation of subarray beamforming showing the advantage over ABF occurring with small subarrays



**Figure 4.** Array gain with increasing number of snapshots for a subarray size of 8 elements: the performance deteriorates down to CBF levels without the fast adaptation criteria



**Figure 5.** Array gains of the optimal subarray and full array beamformers. The two subarray configurations are nearly identical in terms of array gain over the entire spectrum

noise in the two subarray configurations, and is hidden in the full array's (figure 2). A full optimisation is conducted (figure 3) which shows how the performance peaks with both configurations at small subarray sizes, and then becomes inferior to full array beamforming when the size exceeds that of roughly half the array aperture. The optimisation at a certain subarray size for the number of beamforming snapshots

(figure 4) shows the initial benefit of a greater number of snapshots to improve the array gain via a better CSM estimate, which then declines with further snapshots due to the finite time elapsed making the estimate out-dated compared to the new flow noise characteristics. Figure 5 shows the array gains achieved by the adaptive-conventional and adaptive-adaptive beamformers, respectively, in a scenario where the signal is 30° to the broadside of the array and the flow velocity is 20 knots. Also plotted in the figure are the array gains of a full array adaptive beamformer and a full array conventional beamformer as references. The following observations can be made.

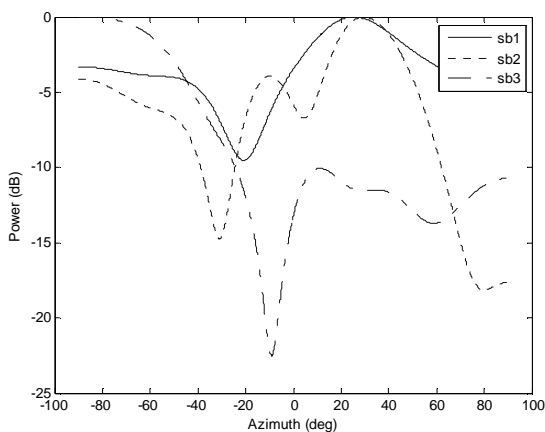
- ◆ The array gain of the full array adaptive beamformer is higher than that of the full array conventional beamformer even in a non-stationary noise environment.
- ◆ The performances of the adaptive-conventional and adaptive-adaptive beamformers are similar, and better than that of the full array adaptive beamformer.

**Mechanisms Involved**

It has been shown that there is an optimal choice of subarray size and snapshots corresponding to the flow conditions and array geometry, but our study has also uncovered the criteria which can predict the effectiveness of the subarray technique in any situation. The need for adaption speed against CSM accuracy can be defined with respect to the dominant pattern of vortices over the array, which allows for the first stage of beamforming to crudely place nulls against the pressure loadings (figure 6).

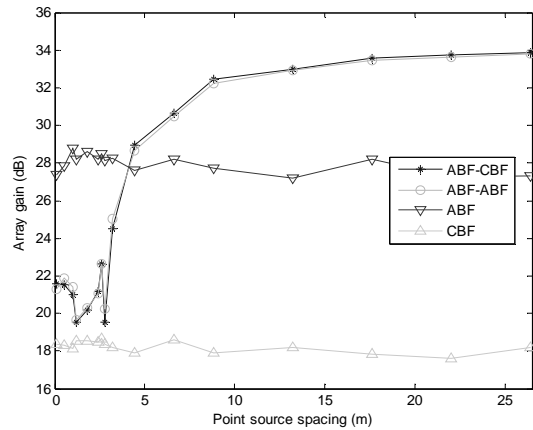
$$\text{FFT period [s]} = 1/\text{frequency resolution} \quad (12)$$

Taking a frequency bin of 50 Hz, this makes the duration of a beamforming snapshot correspond to a time interval of 0.02 seconds. Then consider the flow conditions and array parameters used in figures 3 and 4. Taking 12 snapshots for the first stage of adaptive processing will require a finite time of 0.24 seconds. For the flow speed of 10 m/s this corresponds to a vortex travelling approximately half way over the 5.25 m subarray. For 30 snapshots, the vortex has truly passed over the entire aperture of the subarray and hence offers no benefit over the full array beamformer since the signal is completely smeared in the CSM estimate. Taking further snapshots will not aid in better characterising the signal and will be worse off than the full array beamformer which due to its large aperture has a much narrower main beam and can place better nulls in its beam pattern.

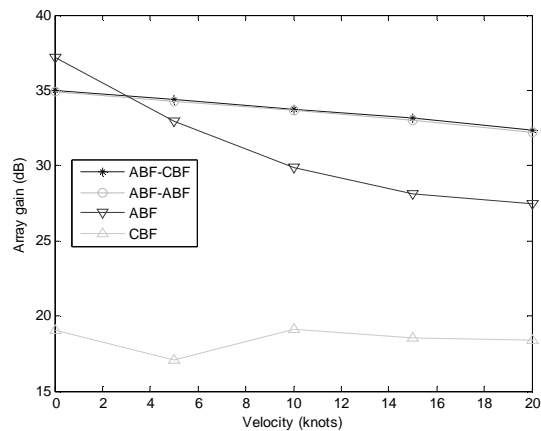


**Figure 6.** Beam patterns at the first stage of processing for a single 8-element subarray, over three consecutive adaptation intervals (sb1, sb2 and sb3), for  $y(f = 500 \text{ Hz}, \theta = 0^\circ)$

To further this theory, if the spacing between dominant vortices in the flow is reduced, the performance benefit of the subarray technique disappears when the spacing is less than the 5.25 m subarray aperture (figure 7). A smaller subarray could be used, but the beamwidth and therefore targeting ability are decreased. Decreasing the flow velocity (figure 8) shows how the full array adaptive beamformer is able to take back its performance through its estimate no longer becoming outdated. A flow velocity approaching 0 m/s is unrealistic for the presence of flow noise, but demonstrates the point that the subarray technique gains its advantage from moving sources only.



**Figure 7.** Deterioration of subarray benefit when the scale of dominant emitters is small relative to the size of the subarray



**Figure 8.** Array gains with velocity. A full array adaptive beamformer reigns superior without the presence of near-field, non-stationary flow noise

**CONCLUSIONS**

A new quadrupole model of flow noise has been given, and the potential of the subarray technique explored through simulated data. The findings show that if there exist large scale turbulent fluctuations akin to vortex shedding along the array surface then the subarray technique is effective with a subarray aperture chosen at this same length scale. The number of snapshots to use for the characterisation of the flow noise has also been found to be dependent on the flow conditions. Our future work will be focused on justifying this model with experimental data in an idealised wind-tunnel like environment. The ABF-ABF and ABF-CBF beamformers offer a similar performance in terms of array gain since there are no far field interference sources for the second stage of

ABF to target, in which case their additional computational complexity will be worthwhile especially in the case of distinguishing two closely placed targets where the bearing resolution will be of importance.

## REFERENCES

- Bao, C, Si, D, Pan, J, 2010, 'On effectiveness of subarray adaptive beamforming for suppressing near-field moving noise', *Proceedings of ISMA2010*, Katholieke Universiteit Leuven, Belgium, Ref. 210.
- Corcos, G.M 1964, 'The structure of the turbulent pressure field in boundary-layer flows', *Journal of Fluid Mechanics*, vol. 18, pp. 353-378
- Cox, H, Lai, H 2004, 'Sub-aperture beam-based adaptive beamforming for large dynamic arrays', *Proceedings of 38<sup>th</sup> ACSSC*, IEEE Press, vol. 2, pp.2355-2358.
- Ffowcs-Williams, J & Hawkings, D 1969, 'Sound Generation by Turbulence and Surfaces in Arbitrary Motion', *Philosophical Transactions of the Royal Society of London. Series A, Mathematical and Physical Sciences*, vol. 264, iss. 1151, pp. 321-342.
- Lee Y, Freese H, Lee W, 2004, 'Subarray beam-space adaptive beamforming for a dynamic long towed- array', *Proceedings of IEEE ASAP 2004*, The 12th Annual Workshop on Adaptive Sensor Array Processing, MIT Lincoln Lab, 16-18 March 2004.
- Lighthill M.J, 1952, 'On Sound Generated Aerodynamically. I. General Theory', *Proceedings of the Royal Society of London. Series A, Mathematical and Physical Sciences*, Vol. 211, No. 1107, pp. 564-587.
- Morse P & Ingard K, 1986, 'Theoretical Acoustics', *Princeton University Press*, McGraw-Hill, Inc. United States.
- Musha T & Kikuchi T, 2005, 'Adaptive signal processing for reducing nearby generated flow noise', *Applied Acoustics*, vol. 66, no.1, pp. 1206-1217.
- Nuttall J, Willett P, 1993, 'Adaptive-adaptive subarray narrowband beamforming', *Proceedings of IEEE ICASSP 1993*, vol. 1, pp. 305-308.
- Peltier, L, Hambric, S, 2007, 'Estimating turbulent-boundary-layer wall-pressure spectra from CFD RANS solutions', *Journal of Fluids and Structures*, vol. 23, pp. 920-937.
- Wagner C, Huttl T, Sagaut P, 2007, 'Large-Eddy Simulation for Acoustics', *Cambridge University Press*, New York, United States.