



# **Implementation of Smart Sensor Interface for Water Quality Monitoring In IoT (Internet of Things) Environment**

D. Sreenivasulu Reddy

Professor, Department of ECE, S V College of Engineering, Tirupati, A.P, India

**ABSTRACT:** Gradual improvement of IoT has lead to a revolution in the wireless communication; this scenario facilitates various application from environmental monitoring to industrial management. Different sensors are available for water quality monitoring which are use to check the quality on following parameters i.e pH, dissolved oxygen concentration, conductivity and temperature etc. Wired networks are mostly used to transfer data by connecting sensor. It is advantageous as it provides reliable communication system for instruments and controls. But connecting the sensors with a wired network will be costly hence low cost wireless technologies are much needed to cut down the cost. In this paper, a method is proposed to design smart sensor interface for water quality monitoring in IoT environment. IoT provide interface to monitor and operate remotely from anywhere and anytime. ATmega(ATMEL 328p) controller is implemented in our proposed system. The proposed system performance is tested on water environment monitoring and improved results are achieved.

**KEYWORDS:** Internet of things (IoT), ATmega328P, Sensors, Cloudcomputing, Zigbee.

## **I. INTRODUCTION**

Data collection about physical phenomena in various applications such as habitat monitoring, and ocean monitoring, and surveillance is a decisive task. IoT has brought rapid advances in modern wireless telecommunication and it is expected that IoT will be beneficial to application areas like healthcare systems manufacturing and industrial systems. Sensor interface device is necessary for detecting various kinds of sensor data of industrial application in IoT environments [1] and we can acquire the sensor data. Hence it will not be complicated for us to understand the outside environment information. To meet the long term industrial environmental requirements data acquisition in IoT, multiple sensor data can be collected at the same time by the acquisition interface device. Nowadays, there are many implementations of IoT devices, like, heart monitoring implants, farm animals equip with biochip transponders, automobiles built-in sensors, field operation device used by fire-fighters for search and rescue. Currently the implementation of smart thermostat systems and washer/dryer for remote monitoring by using Wi-Fi [2] is do ne. It is not a futuristic or aspirational technology trend; rather it already exists in our devices, cloud infrastructure, data, and sensors. Microsoft Corporation has delivered a unique and integrated approach for all enterprises to capitalize on IoT by gathering, processing and storing data. The result of this method was extended from broad product portfolio such as computers, tablets and industrial devices on edge of enterprise network to backend system and services and diverse partner ecosystem. Computer system with specified functions within a bigger mechanical or electrical system, much with real time computing restrictions are known as embedded system. Embedded systems consist of mechanical parts and hardware and it also controls the devices that are common in use. The program instructions written for embedded systems are referred to as firmware and are stored in read-only memory or ash memory chips. The AVR microcontrollers from Atmel are micro-controller with low cost and with C compiler. These controllers costs low, the power consumption is also low i.e. only a few milliamps at 3.3 or 5V. It consists of hardware interrupts that are used to monitor the state of a pin, hardware timers/counters, digital I/O allow interaction with the world of electronics, Analog to Digital Conversion allow communication with dozens of sensors which output analog voltages between 0 and 5V, Serial protocols to allow AVRs to communicate with other high-level chips and computers. [3]It also consists of flash ROM, EEPROM that is byte-addressed which is easily changed at run-time and RAM that stores variables and data at

# International Journal of Innovative Research in Computer and Communication Engineering

(An ISO 3297: 2007 Certified Organization)

Vol. 1, Issue 6, August 2013

run time. There are two main branches of AVR chips and they are ATTINY and ATMEGA branches. This microcontroller will be used as interface device to collect data from sensors and transfer it to monitoring station wirelessly. This provides efficient method to interface sensing devices and monitor through IoT environment. The system proposed is going to monitor various parameters of water to verify its quality, and monitor them for industrial application. The parameters such as temperature, turbidity, light intensity, pH will be sensed by different sensors and then microcontroller will collect the sensed data for processing and will transmit it through internet using IoT. Internet services are expanded as Internet of Things (IoT) and it allows daily needed things to connect with user and provide access remotely from anywhere. In 1998 IoT was began and in 1999[4] Kevin Ashton was the first to put forward the term Internet of Things. The following figure (fig no:1) shows the projected market share of IoT applications[5]. The remainder of this paper is organized as follows. We provide an overview of IoT architectures and water quality monitoring in Section II. Section III describes the architecture of the proposed system and working of the proposed system with the implementation details is explain in Section IV and Conclusion is then given in Section V.

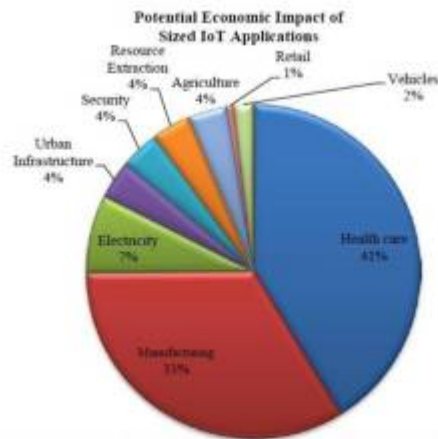

Fig.1 Projected market share of dominant IoT applications by 2025[5].

## II. IOT ARCHITECTURE AND WATER QUALITY MONITORING

One of the major problems with the IoT is that it is too vast and a broad concept that is not proposed and fix architecture. The idea of IoT to work for must comprise of an assortment of sensor, network, communications and computing technologies, amongst others [6]. We have studied following IoT architectures (models) proposed by several researchers and practitioners. [7] Described a three key level architecture of IoT while [8] described a four key level architecture. [9] Proposed a five layered architecture utilizing the best features of the architectures of Internet and Telecommunication management networks based on TCP/IP and TMN models respectively.

### A. ITU ARCHITECTURE

From the recommendations of the International Telecommunication Union (ITU), the communication network, i.e. Architecture of Internet of Things comprises of

- (i) The Sensing Layer
- (ii) The Access Layer
- (iii) The Network Layer
- (iv) The Middleware Layer
- (v) The Application Layers

This shows the Open Systems Interconnection (OSI) referencemodel for network and data communication.

### B. XU CHENG, MINGHUI ZHANG, FUQUAN SUN'S ARCHITECTURE FORUM ARCHITECTURE

With development of IoT, a number of multi-layered security architectures are proposed. Similarly a six-layered architecture was also proposed based on the network hierarchical structure [10]. So basically it's divided into six layers as shown in the Fig. 2.

# International Journal of Innovative Research in Computer and Communication Engineering

(An ISO 3297: 2007 Certified Organization)

Vol. 1, Issue 6, August 2013

## C. WATER QUALITY MONITORING

Water quality monitoring is the major challenge for health and security authorities. Although while leaving the purification plant the quality of drinking water is generally high but the quality drops on its way to the consumers. If the reservoirs are not cleaned periodically they may become the source for degrading the water quality. Water quality is an important factor in many industries and if it's not up to the mark then overall quality of the product being manufactured

will be affected. So a robust, fast and simple sensor system is needed to monitor the quality of water. We have considered pH, dissolved oxygen concentration, conductivity and temperature as main parameters for the water quality assessment.

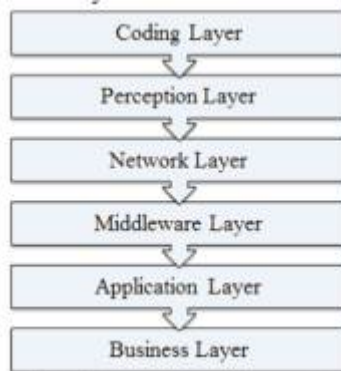

Fig.2 Six Layer IoT Architecture [10]

Electronic tongue [11], [12] ] is also known as artificial tongue, is used to analysis the total complex chemistry of sample. Basically, Electronic tongue is a multi-sensor array system. These system shows the following advantages: (a) requires small sample volume, (b) decreased measurement time, (c) objectivity compared to sensory panel, (d) small size of sensors, (e) easily operated by unskilled personnel and (f) amenability to fully automatic long-term routine application. The schematic diagram of electronic tongue is shown in Fig 3. For testing our simulation which is based on IoT we have considered five parameters whereas in [13] only two parameters are taken in to consideration and the system is based on WSN for transmitting the data.

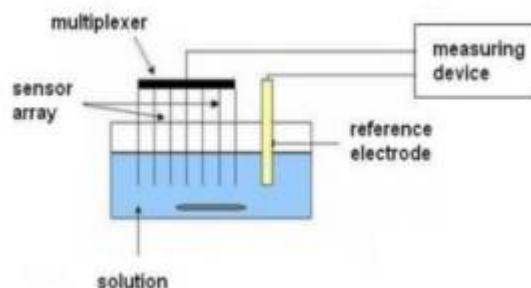

Fig.3 Schematic diagram of Electronic Tongue

## III. PROPOSED SYSTEM

There are various methods used in this process. They are M2M technology, the IoT process and Cloud computing is also used. Machine to Machine (M2M) refers to technologies that allow both wireless and wired systems to communicate with other devices which are of same type. M2M is a broad term as it does not pinpoint specific wireless or wired networking or communications technology. M2M is considered an integral part of the Internet of Things (IoT) and gives various benefits to business and industry as it has a wide range of applications such as automation of industries, Smart Cities, logistics, health, defense, etc for monitoring and control purposes. Cloud computing (also

# International Journal of Innovative Research in Computer and Communication Engineering

(An ISO 3297: 2007 Certified Organization)

Vol. 1, Issue 6, August 2013

called as “the cloud”) focuses on increasing the effectiveness of the shared resources. Cloud resources are usually not just shared by multiple users but are also reallocated dynamically as per user needs. This can work for allocating resources to users. Cloud is of two types, private cloud and public cloud. The scheduling algorithm is used for scheduling the data when the data from the server is accessed by multiple users. The algorithm schedule the data based on the time. We have used Proteus design suite for demonstration of our proposed system as it has the ability to co-simulate high and low-level micro-controller code in the context of a mixedmode SPICE circuit simulation. For sensing the parameters we have used LM35 sensor for temperature, PHE-45P ph sensor, and NQ2 for CO2 sensor, LDR sensor for light intensity and Greenspan TS100 turbidity sensor.

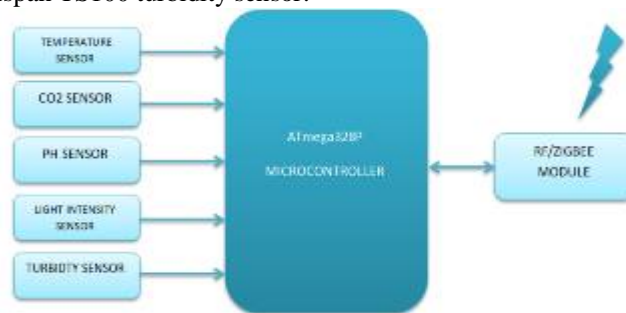

Fig 4: Monitoring unit

The aim of the proposed system is to overcome the drawback of the existing system by using IoT and AVR 32-bit

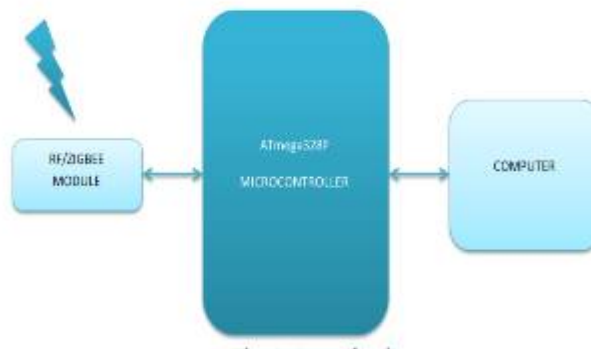

Fig. 5: Control unit

microcontroller. The designed system is by using AVR 32-bit micro controller which supports different features and algorithms for the development of industrial automation systems. Using AVR controller we can connect all types of sensors and sensor network to AVR controller using different wired or wireless technology. Many open source libraries and tools are available for AVR board development and controlling. We can monitor and control the sensor parameters remotely using internet and web server. The system incorporate of two units one is monitoring unit and another is control unit as shown in figures (see fig 4 and fig 5). The system describes the development of a wireless industrial environment measuring temperature, co2, pH level of water, turbidity of water and light detection. Where, the wireless connection is implemented to gain data from the multiple sensors and reducing the setup difficulty. By using Zigbee technology we send the sensors data to authorized person.

# International Journal of Innovative Research in Computer and Communication Engineering

(An ISO 3297: 2007 Certified Organization)

Vol. 1, Issue 6, August 2013

## A. FLOW CHART

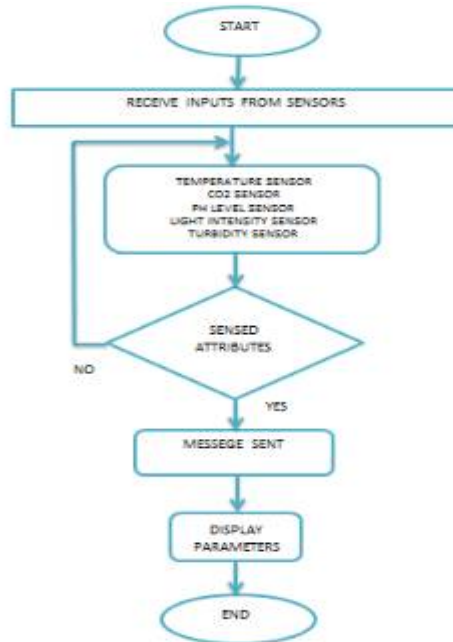

Fig. 6: Flow chart of proposed system

The system receives the inputs from the sensors and then the attributes are sensed, if all attribute are sensed the message is sent and the parameters are displayed on the screen.

## B. HARDWARE DESIGN

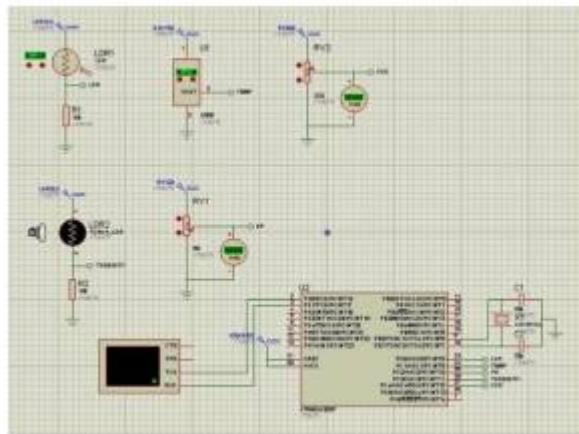

Fig. 7: Schematic circuit diagram of simulation

The interface device which we are using can automatically discover sensors connected to it and collect multiple sets of sensor data accurately & parallel with highspeed. AVR is the core controller of the interface device. It is used to control data acquisition, processing, and transmission perfectly, and make perform preprocessing on collected data. The driver of chips on the interface device is also programmed inside the AVR. Multiple scalable interfaces are designed on the equipment which can be extended to 8-channel analog signal interface & 24 -channel digital signal interface. This ensures that our device guarantees the diverse collection of the information by connecting with a number of sensors among the application of industrial IoT.



# International Journal of Innovative Research in Computer and Communication Engineering

(An ISO 3297: 2007 Certified Organization)

Vol. 1, Issue 6, August 2013

These received parameters can be monitored by other persons on other locations through internet access. This makes the device more flexible and efficient. The database can be maintained using cloud computing and for storing the parameters for future references.

## Temperature Sensor

The LM35 series is temperature sensors and its output voltage is linearly proportional to the Celsius (Centigrade) temperature. Advantage of LM35 is that the user does not required to subtract a big constant voltage from its output to obtain convenient Centigrade scaling.

## pH Sensor

pH is an essential parameter to be measured and controlled in the world of process. The pH of a water indicates how basic (alkaline) or acidic it is. The pH term describes the values of the hydrogen ion concentration which normally range in between 1 and  $10 \times 10^{-14}$  gram-equivalents per litre – into numbers between 0 and 14. PHE-45P ph sensor can perform in the hardest of environments, including applications that poison conventional pH sensors.

## Light Sensor

LDR is use to sense the intensity of light of the atmosphere. The resistance of the light varies as the intensity of light changes.

## Turbidity Sensor

The technology to determine turbidity depends on optical techniques, where water is pass through a tube and a beam of light is transmitted through a cross section of tube. The photons which make up a beam of light pass through the water being tested; few are reflected by the particles suspended in the solution while others pass through unobstructed. Two optical detectors are used to measure the transmitted and scattered light photons simultaneously. If the water is dirtier then less light gets through and light is spread. Water turbidity is determined by analysis of the ratio of the spread out light signal divided by the transmitted light signal. The Greenspan

TS100 Turbidity Sensor utilizes a high gain infrared optical system to detect the back-scatter intensity of debarred particles by transmitting a beam of 880nm wavelength and measuring the received intensity of reflected light.

## IV. RESULTS

As per the proposed system, we have implemented the design in the Proteus design suite and using embedded C coding in Arduino IDE. Fig.8 and Fig. 9 shows the simulation results obtained by processing the data received from different sensors such as LDR, temperature, pH level, turbidity and CO<sub>2</sub> concentration of water. These sensors are sensing the physical parameters and providing them to the connected AVR controller, where all these signals are processed. The values of light intensity of atmosphere, temperature of water are measured directly. But the other parameters like pH, CO<sub>2</sub> and turbidity have to be caliber. PH sensor converts the pHlevel into the corresponding voltage value, thus measuring the proper voltage we have got the actual pH value. From 0 to 6 pH value the water is acidic, from 8 to 14 it is basic and at value 7 it is neutral. Thus according to these ranges we have decided whether the water is acidic, basic or neutral. Similarly, the turbidity can be measured from the voltage level we have received and measured in unit NTU. The received voltage has caliber into NTU and the results has been shown if greater than 400NTU then water is not transparent else it is transparent. The concentration of CO<sub>2</sub> converts the resistance of the device thus changing the value of output voltage, and this voltage value is converted in ppm of CO<sub>2</sub> particles. The obtained result in the below fig. 8 signifies that water quality on the listed parameters, after processing the information received by the sensors conclusion is drawn by on the basis of the values generate for Turbidity level 437NTU indicates that the water is not transparent likewise the other quality parameters are considered such as if the pH value is 7 the water is neutral and the value of co<sub>2</sub> greater than 700ppm shows that water is having high concentration of co<sub>2</sub> particles.

# International Journal of Innovative Research in Computer and Communication Engineering

(An ISO 3297: 2007 Certified Organization)

Vol. 1, Issue 6, August 2013

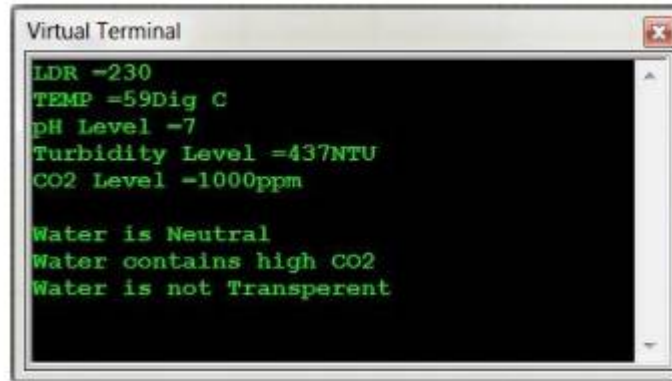

```
Virtual Terminal
LDR =230
TEMP =59Dig C
pH Level =7
Turbidity Level =437NTU
CO2 Level =1000ppm

Water is Neutral
Water contains high CO2
Water is not Transperent
```

Fig. 8: Simulation Result

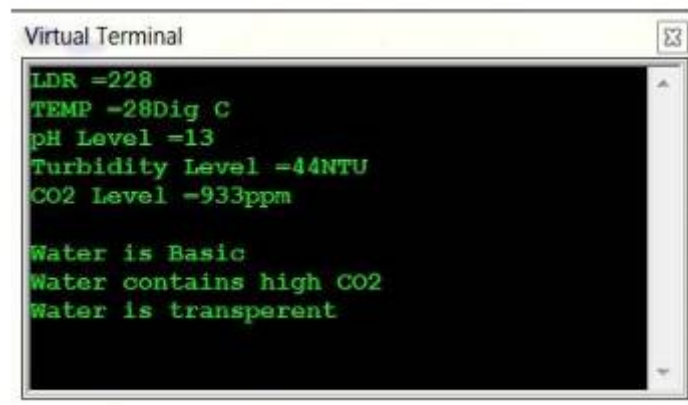

```
Virtual Terminal
LDR =228
TEMP =28Dig C
pH Level =13
Turbidity Level =44NTU
CO2 Level =933ppm

Water is Basic
Water contains high CO2
Water is transparent
```

Fig. 9: Simulation Result

## V. CONCLUSION AND FUTURE SCOPE

In the proposed system ATmega328P is used as core controller overcoming the disadvantages of CPLD. The programming module is implemented using embedded c coding. The performance of the system is tested by doing simulations on Proteus Design suite . Proposed system monitors the various parameters (i.e. temperature, pH level, turbidity of water, co2 and light intensity) of water to verify its quality and monitor them for industrial application. The parameters will be sensed by different sensors and then microcontroller will collect the sensed data for processing and will transmit it via internet using Internet of Things. The application of this smart sensor interfacing device greatly simplifies the design of peripheral circuit, and makes the whole system more extensible. By taking real-time monitoring of water environment in IoT environment as an example, we can verify the system performance in practical application. In future, the work can be extended with more parameters for water quality monitoring.

## REFERENCES

- [1] M. T. Lazarescu, "Design of a WSN platform for long-term environmental monitoring for IoT applications," IEEE J. Emerg. Sel. Topics Circuits Syst., vol. 3, no. 1, pp. 45–54, Mar. 2013.
- [2] L. Xu, "Introduction: Systems science in industrial sectors," Syst. Res. Behav. Sci., vol. 30, no. 3, pp. 211–213, 2013.
- [3] Bharani M., S. Elango, S. M. Ramesh and R. Preetilatha, "An Embedded System Based Monitoring System For Industries By Interfacing Sensors With ATmega", IJARECE 2014.
- [4] Dr. V. Bhuvaneshwari, Dr. R. Porkodi, "The Internet of Things (IoT) Applications and Communication Enabling Technology Standards: An Overview", International Conference on Intelligent Computing Applications, 2014, pp. 324-329
- [5] Al-Fuqaha, A.; Guizani, M.; Mohammadi, M.; Aledhari, M.; Ayyash, M., "Internet of Things: A Survey on Enabling Technologies, Protocols, and Applications," in *Communications Surveys & Tutorials, IEEE* , vol.17, no.4, pp.2347-2376,Fourthquarter 2015 doi: 10.1109/COMST.2015.2444095
- [6] Gigli, M. and Koo, S. (2011) Internet of Things, Services and Applications Categorization. *Advances in Internet of Things*, 1, 27-31.



ISSN(Online): 2320-9801  
ISSN (Print) : 2320-9798

# International Journal of Innovative Research in Computer and Communication Engineering

*(An ISO 3297: 2007 Certified Organization)*

**Vol. 1, Issue 6, August 2013**

- [7] Wang Chen, "AN IBE BASED SECURITY SCHEME OF INTERNET OF THINGS," in Cloud Computing and Intelligent Systems (CCIS), 2012, pp. 1046, 1049
- [8] Hui Suo, Jiafu Wan, Caifeng Zou, Jianqi Liu, "Security in the Internet of Things: A Review," in Computer Science and Electronics Engineering (ICCSEE), 2012, pp. 648-651
- [9] MiaoWu, Ting-lie Lu, Fei-Yang Ling, ling Sun, Hui-Ying Du, "Research on the architecture of Internet of things," in Advanced Computer Theory and Engineering (ICACTE), 2010, pp. 484-487
- [10] Xu Cheng, Minghui Zhang, Fuquan Sun, "Architecture of internet of things and its key technology integration based-on RFID," in Fifth International Symposium on Computational Intelligence and Design, pp. 294-297, 2012
- [11] Y. Sasaki, Y. Kanai, H.Ushida and T. Katsube, "Highly sensitive taste sensor with a new differential LAPS method ", Sensor and Actuators B 25, 819-822, 1995.
- [12] Qingping Chi, Hairong Yan, Chuan Zhang, Zhibo Pang, and Li Da Xu, "A Reconfigurable Smart Sensor Interface for Industrial WSN in IoT Environment ", IEEE Transactions on Industrial Informatics, Vol. 10, NO. 2, MAY 2014, pp. 1417-1425.
- [13] Ruan Yue and Tang Ying, "A water quality monitoring system based on wireless sensor network & solar power supply", International Conference on Cyber Technology in Automation, Control, and Intelligent Systems March 20-23, 2011, Kunming, China.