

System design of a large fuel cell hybrid locomotive

A. R. Miller^{a,1}, K. S. Hess^a, D. L. Barnes^a, and T. L. Erickson^a

^aVehicle Projects LLC, 621 17th Street, Suite 2131, Denver, CO 80293, USA

Abstract

Fuel cell power for locomotives combines the environmental benefits of a catenary-electric locomotive with the higher overall energy efficiency and lower infrastructure costs of a diesel-electric. A North American consortium, a public-private partnership, is developing a prototype hydrogen-fueled fuel cell-battery hybrid switcher locomotive for urban and military-base rail applications. Switcher locomotives are used in rail yards for assembling and disassembling trains and moving trains from one point to another. At 127 tonne (280,000 lb), continuous power of 250 kW from its PEM (proton exchange membrane) fuel cell prime mover, and transient power well in excess of 1 MW, the hybrid locomotive will be the heaviest and most powerful fuel cell land vehicle yet. This fast-paced project calls for completion of the vehicle itself near the end of 2007. Several technical challenges not found in the development of smaller vehicles arise when designing and developing such a large fuel cell vehicle. Weight, center of gravity, packaging, and safety were design factors leading to, among other features, the roof location of the lightweight 350-bar compressed hydrogen storage system. Harsh operating conditions, especially shock loads during coupling to railcars, require component mounting systems capable of absorbing high energy. Vehicle scale-up by increasing mass, density, or power presents new challenges primarily related to issues of system layout, hydrogen storage, heat transfer, and shock loads.

Keywords: Engineering design; Fuel cell hybrid locomotive; Hydrogen storage; Heat transfer; Shock loads

1. Introduction

Fuel cell power for locomotives combines the environmental benefits of a catenary-electric locomotive with the higher overall energy efficiency and lower infrastructure costs of a diesel-electric. Catenary-electric locomotives – when viewed as only one component of a distributed machine that includes an electricity generating plant, transformers, and transmission lines – are the least energy-efficient and most costly locomotive type². Diesel-

¹ Corresponding author. Tel.: + 1 303 296 4218; fax: + 1 303 296 4219.

Email address: arnold.miller@vehicleprojects.com (A.R. Miller)

² The efficiencies of catenary-electric and diesel-electric locomotives are similar; their respective efficiencies depend on the specifics of the application, in particular, the duty cycle. To make a meaningful comparison, consider using a diesel engine as the prime mover in the two types of locomotives.

For a catenary electric, the following are midpoints of the typical range of efficiencies for the various processes in taking the energy of diesel fuel to traction power in the locomotive: Mitsubishi 8 MW diesel engine-alternator for an electricity generating plant (43.5%), voltage conversion (97%), copper transmission from power plant to locomotive (80%), onboard conversion to traction power (85%). The product of these estimates gives the overall efficiency of a catenary-electric locomotive as 29%. Coal-fired steam plants have similar efficiencies to the diesel plant.

electric locomotives, while collectively worse as sources of air pollution than an equal number of catenary-electric locomotives driven by a coal-fired power plant, are more energy efficient and have a less expensive energy infrastructure. Fuel cell locomotives are expected to be slightly more energy efficient than diesel locomotives, and because its fuel infrastructure will be homologous to that of a diesel, it should have similar fuel infrastructure costs. Elimination of high catenary-electric infrastructure costs by fuel cell locomotives is the key to economic viability of electric trains in low population density regions such as the western USA.

Furthermore, fuel cell locomotives can help resolve the related issues of urban air quality and national energy security affecting the US rail industry and transportation sector as a whole. The issues are related by the fact that about 97% of the energy for the transport sector is based on oil, and more than 60% is imported. A North American consortium (see Table I), a public-private partnership, is developing a prototype hydrogen-fueled fuel cell-battery hybrid switcher locomotive (see Fig. 1) for urban and military-base rail applications

Table I
Project consortium

Member	Tasks
Ballard Power Systems	Fuel cell manufacturer
BNSF Railway Company	Industry funder; vehicle integrator; rail-yard demo
Concurrent Technologies Corporation (pending)	Testing of fuel cell power modules
Defense Gen. & Rail Equipment Center (DGRC)	Adviser on military applications; power-to-grid demo
Dynetek Industries	Hydrogen storage manufacturer
General Atomics	Power electronics developer
RailPower Hybrid Technologies	Manufacturer of Green Goat platform
Transportation Technologies Center, Inc	Railway safety regulations interpreter
University of Nevada - Reno	Refueling system
Vehicle Projects LLC	Engineering design; consortium & project management
Washington Safety Management Solutions LLC	Safety analysis

leading to commercial locomotives that have the potential to: (1) reduce air pollution in urban railyards, particularly yards associated with seaports; (2) increase energy security of the rail transport system by using a fuel (hydrogen) independent of imported oil; (3) reduce atmospheric greenhouse-gas emissions; and (4) serve as a mobile backup power source ("power-to-grid") for critical infrastructure on military bases and for civilian disaster relief efforts. Switcher locomotives are used in rail yards for assembling and disassembling trains and moving trains from one point to another.

For a diesel-electric, the midpoint efficiencies are: 3 MW onboard diesel engine (37.5%), engine ancillaries (94%), alternator (96.5%), onboard conversion to traction work (90%). Overall efficiency for a diesel-electric locomotive is therefore 31%.

A catenary-electric is much more costly than an equivalent diesel-electric locomotive because of the higher infrastructure costs (US\$6-8 million per mile). Relatively low infrastructure cost is the reason that diesel-electrics are almost universally used on large land masses with dispersed population centers, such as the USA.

At 127 tonne (280,000 lb), continuous power of 250 kW from its PEM (proton exchange membrane) fuel cell power plant, and transient power well in excess of 1 MW, the hybrid locomotive will be the heaviest and most powerful fuel cell land vehicle yet. The schedule for this fast-paced project calls for completion of the vehicle itself near the end of 2007. Contributing to the fast pace are, (1) the platform of the fuel cell-hybrid locomotive is based on a commercially available diesel-battery hybrid switcher (Green Goat™), and (2) both the fuel cell power plant and roof-mounted lightweight compressed-hydrogen storage system are derived from the Citaro™ fuel cell transit bus. Citaro fuel cell buses, widely used in European cities, have a combined operating experience of more than 1.5 million kilometers.



Fig. 1. Fuel cell-hybrid switcher platform vehicle. As shown, the diesel fuel tank and genset have been removed in preparation for retrofitting the fuel cell power plant and hydrogen storage. (Photo courtesy of RailPower Hybrid Technologies)

Several design and integration challenges arise when implementing such a large hydrogen fuel cell vehicle. Weight, center of gravity, packaging, and safety were design factors leading to, among other features, the roof location of the lightweight compressed hydrogen storage system. Harsh operating conditions, especially shock loads during coupling to railcars, require component mounting systems capable of absorbing high energy. Additionally, system design must address railway-industry regulations governing safety and such events as derailment, side impact from yard traffic, refueling, and maintenance.

Design and development of large fuel cell vehicles (those with weights above 100 tonne or power above 1 MW) encounter technical challenges not found in smaller vehicles. Changes in the properties of physical or chemical processes as a function of scale or size are well-known; for example, the thermodynamic efficiency of heat engines increases with size of the machine. In this paper, we report design challenges based on our experience in developing the largest hydrogen-fuel cell vehicle to-date.

In previous projects, Vehicle Projects LLC and its consortia have developed a fuel cell-powered underground mine locomotive, the world's first fuel cell locomotive [1,2] and a 23-tonne fuel cell-hybrid mine loader [3,4].

2. Results and discussion

2.1. Duty cycle

The rational starting point for engineering design of a fuel cell-hybrid vehicle is the duty cycle [5]. Figure 2 shows a typical duty cycle – that is, function $P(t)$, where P is vehicle power and t is time – recorded from an in-service yard switching locomotive. The

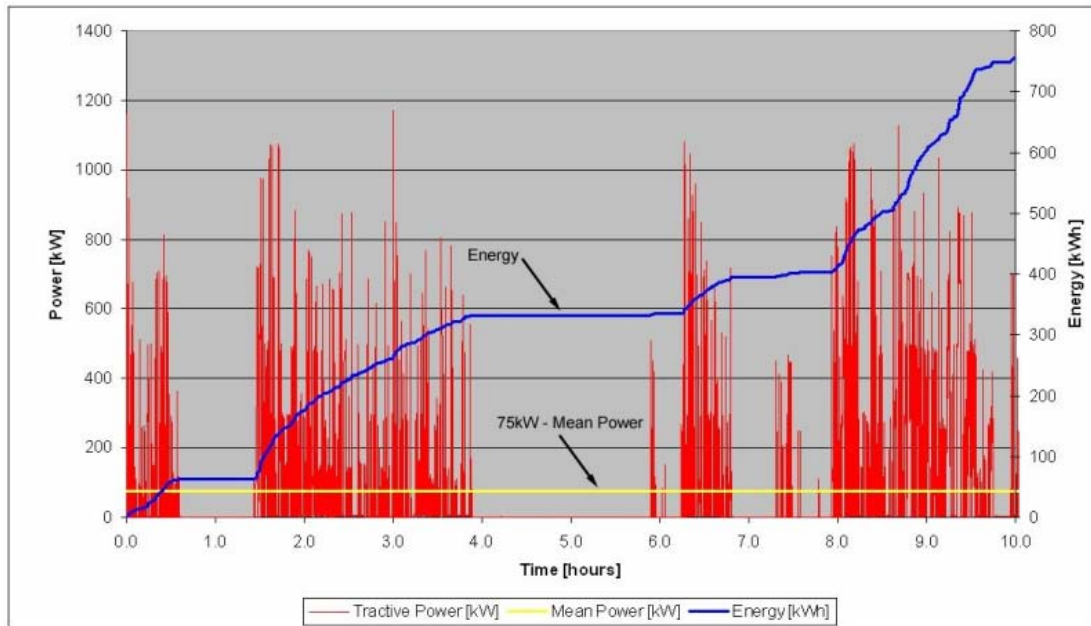

Fig. 2. Example switcher locomotive duty cycle. 75kW mean power is based on 20-h shift.

vehicle's required mean power, maximum power, power response time, and power duration are calculated from function P ; its energy storage requirements are calculated from the integral of P . As shown, peak power commonly reaches 600-1000 kW for durations of no more than several minutes, usually corresponding to acceleration of train cars or uphill movement. Between the peaks, however, the power requirements are minimal when coasting a load, or zero when idling between move operations. The idle time, varying from minutes to hours between operations, usually accounts for 50-90% of the overall operation schedule. Our analysis of multiple duty-cycle data sets from various railyards shows that the short duration of peak power and long periods of idle time result in mean power usage in the range of only 40-100 kW.

For a hybrid vehicle to be self-sustaining, the prime mover, a hydrogen PEM fuel cell in this case, must provide continuously at least the mean power of the duty cycle. The auxiliary power/energy storage device, which are lead acid batteries in this hybrid, must store sufficient energy to provide power in excess of the continuous power rating up to the peak power requirement of the vehicle, which is around 1100 kW in this application. This power and energy must be available while not exceeding a rather shallow depth of discharge, which significantly increases the size of the battery. Allowable depth of discharge is a function of acceptable battery cycle life and recharge rate. With lead-acid batteries, depth of discharge is limited to approximately 80% of full capacity. The relatively large energy capacity of the batteries allows satisfactory load-following by the fuel cell power plant and moreover increases stack life. Because the battery capacity of this vehicle is based on the original 200kW diesel prime mover, it will easily provide the storage required for our 250 kW fuel cell prime mover.

2.2. Vehicle layout and packaging

Integration of the complete fuel cell system in the locomotive is shown in Fig. 3. The rear compartment houses the fuel cell power plant – based in part on the power plant of a Citaro fuel cell transit bus – along with our cooling systems and power converter.

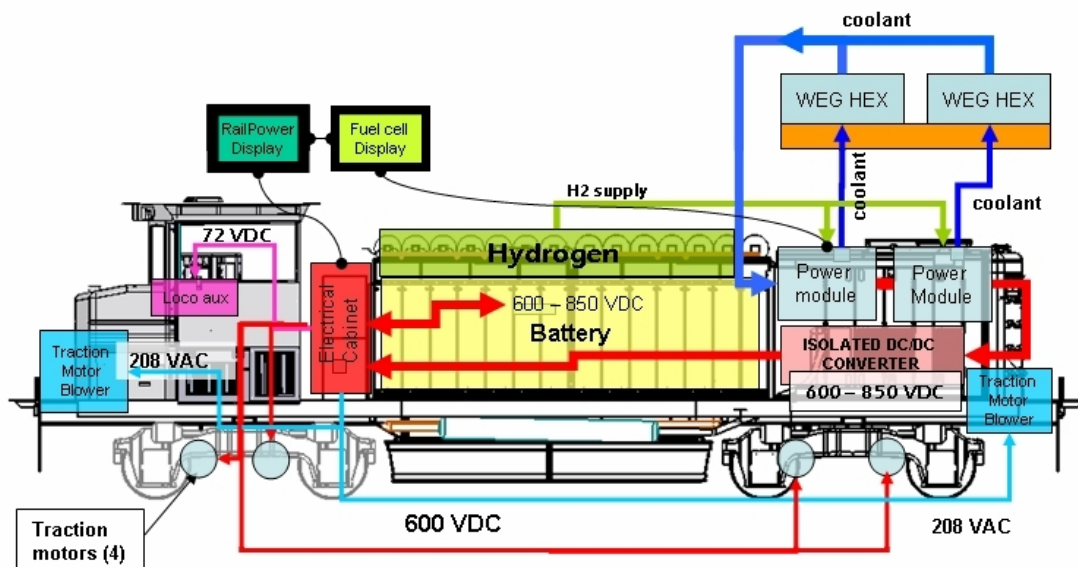

Fig.3. System layout of the fuel cell hybrid locomotive including 250 kW net fuel cell power plant, DC-to-DC converter, hydrogen storage, and control interface.

Fourteen carbon-fiber composite tanks, located above the battery, store a total of 70 kg of hydrogen at 350 bar. Both the fuel cell power converter and the traction battery supply power to a single high-voltage bus that then distributes power to the existing locomotive systems as well as the 600 VDC traction motors.

Integration of the fuel cell system has been influenced by several key factors including safety, base platform packaging constraints of the Green Goat donor chassis, locomotive environmental operating conditions, and serviceability. In addition, there is consistent attention to minimizing system cost, use of off-the-shelf, proven hardware, and consideration of future volume manufacturing. With these factors guiding design, the end product will consist of five bolt-in modules: the fuel cell power plant, DC/DC power converter, cooling module, and two hydrogen storage modules. Each of the five modules will be independently tested, then tested as an integrated system, and finally installed in the locomotive.

The largest of the fuel cell system modules are the hydrogen storage modules. Each module consists of seven carbon fiber/aluminum cylinders that collectively store approximately 35 kg of compressed hydrogen. Given the physical space required for the cylinders, it was only feasible to mount the hydrogen under the chassis or above the existing battery pack. A thorough safety analysis highlighted two factors that led to the packaging of the hydrogen system above the battery pack. First, because of the buoyancy of hydrogen, storing hydrogen below void volumes in the locomotive platform, battery rack, and rear hood could lead to confinement of leaked hydrogen and increase the possibility of detonation. In contrast, roof-line storage allows for harmless upward dissipation of hydrogen in the event of a leak. Second, locating the hydrogen tanks on the roof minimizes the likelihood of damage from common events such as derailment, track debris, and impact from yard traffic, such as fueling trucks. Because of the relatively light weight of the hydrogen storage tanks (about 100 kg each), the roof location has minimal effect on the

vehicle's center of gravity. Indeed, after conversion to hydrogen-fuel cell power, a ballast of approximately 9,000 kg will be placed in the undercarriage to bring the locomotive weight to its specified value of 127 tonne. Locomotives have a specified weight to support required tractive effort, which is limited by wheel adhesion.

Reversible metal-hydride storage, the safe and compact technology we have used in our mine vehicles [4], was also considered for the locomotive; however, it was not selected because of its lack of commercial availability, high cost, and surprisingly for a locomotive, its low gravimetric hydrogen density. The most appealing attribute of a metal hydride system is its ability to store hydrogen at very low pressure and its self-limiting characteristics for rate of hydrogen release. Weight was a limiting factor on this vehicle because of the high weight of the lead-acid battery pack, but it may not be for future locomotives with smaller or lighter batteries or other auxiliary storage systems. Moreover, as metal-hydride technology continues to mature, it will presumably become more readily available and cost effective.

The fuel cell power plant, power converter, and cooling module are housed in the rear compartment. Already housed in the rear compartment are the locomotive air compressor, which is used for brakes and various other locomotive systems, and a blower motor that provides cooling to the rear traction motors located on the locomotive trucks. These two components occupy the lower left side of the rear compartment and were not modified in order to minimize redesign of the existing locomotive systems. Service points of the power plant system greatly influenced the overall component layout in the rear compartment (Fig. 4 illustrates the service points). Each of these service and access points – de-ionized water fill and filter,

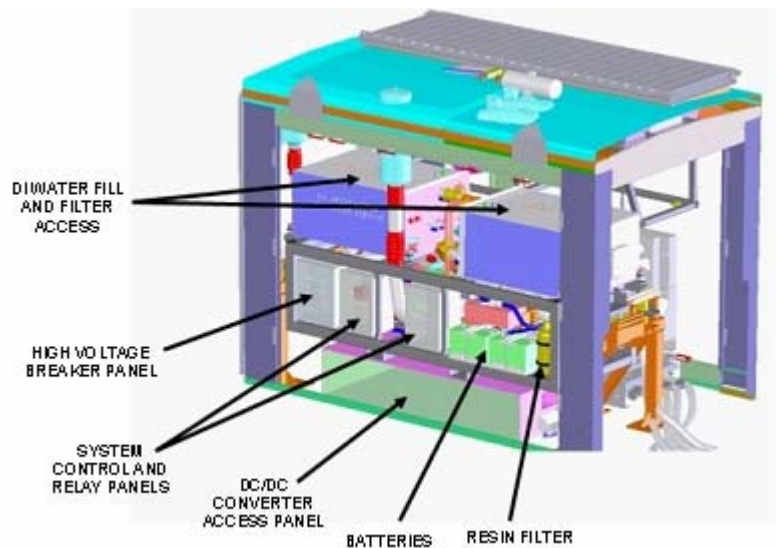

Fig. 4. Exterior accessible service points. The system was packaged to allow for maintenance and service access while on board the locomotive.

electrical panels, DC/DC converter panel, batteries, and resin filter – can be accessed from the outer platform of the locomotive. Longer service-interval components, such as air pre-filter, air compressor belt, and air system lubricant, can be accessed from within the rear compartment. All service points are located on the perimeter of the fuel cell power plant to allow full service without module removal. As shown in Fig. 5, the power plant resides on the right side of the rear compartment. Because the power converter requires minimal access, it is located below the power plant; this allowed the fuel cell stack modules to be oriented symmetrically opposite on the same plane, thus allowing access to the stack module top covers or removal of only the stack panels. This layout also allows symmetric piping of air and coolant to both fuel cell stack modules, and this results in closely balanced

flow for the air and coolant systems, which are driven by a single compressor and pump, respectively.

The cooling module, shown in Fig. 5, consists of the primary and secondary radiators, which reside in the upper left half of the rear compartment. The cooling module will pull air from the lower half of the rear compartment and exhaust it through roof flaps. In addition to providing airflow through the radiators, the cooling system will provide constant airflow in the rear compartment to preclude confinement of accidentally leaked hydrogen.

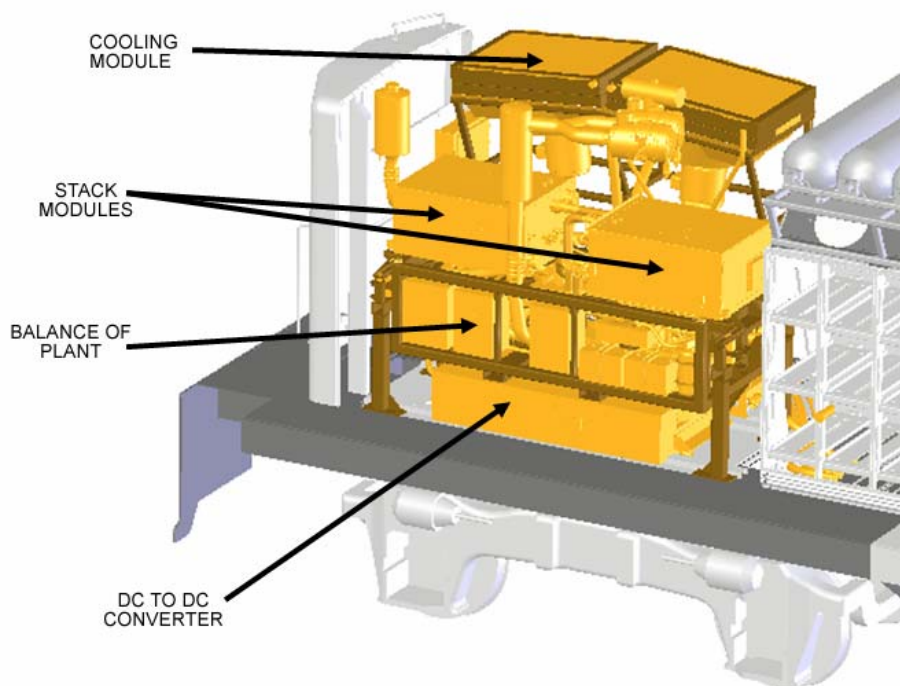

Fig. 5. Rear compartment layout. Systems were designed as bolt in modules, requiring minimal modifications to the locomotive platform. This allows for off line fabrication and testing of modules prior to vehicle installation.

2.3.2. Stack modules

At the heart of the power module are two Ballard Power Systems [6] stack modules. The stack module has been used in a public passenger bus program with combined operational experience of 1.5 million kilometers. The stack modules contain Ballard Mk902 stacks; each stack module is rated at 150 kW gross power at 624 VDC, for a total of 300 kW gross power at 624 VDC. Each stack module includes the auxiliary components for air and hydrogen humidification, water recovery, hydrogen recirculation, and hydrogen purge. Hydrogen is supplied to the stack modules at nominally 12 bara and is pressure-regulated and re-circulated inside the stack module.

2.3.3. Air delivery

The air system operates at a maximum air pressure of ~3 bara, with a maximum mass flow of ~300 g/s. Three bara air pressure is considered "high pressure" for a PEM type fuel cell system. Operating at higher pressure provides higher current density and hence higher power density but results in parasitic losses near 20% of gross power (versus

2.3. Subsystems

The locomotive's energy and power system consists of four major subsystems: power module, hydrogen storage, power electronics, and control.

2.3.1. Power module

The power module, which produces electric power from hydrogen and air, itself consists of three subsystems: stack modules, air delivery, and cooling. The support systems for the stacks, such as the air system, water management, and cooling system, are referred to collectively as the "balance of plant" (BOP).

~10% for a 1.5-1.8 bara air system). Some energy of compression in our system is recovered by exhausting the cathodic air through a turbine.

To attain the 3-bara operating pressure, the air system utilizes two-stage compression. The first stage employs a 55-kW electric motor (360 VDC) driving a twin-screw type compressor, which provides compression up to approximately a 2.7 pressure ratio. The second stage is a variable vane turbo compressor that is driven only by exhaust air. Using closed loop control with an actuator, the turbo's variable vane position is adjusted to change the speed and direction of air that flows into the turbine – thus controlling system backpressure while simultaneously providing additional air pressure boost. The air system also incorporates a liquid-to-air intercooler between compression stages, inlet filtering before compressor, inlet filtering before fuel cell stack, and silencers on both intake and exhaust to manage high noise levels intrinsic to screw type compressors.

2.3.4. Cooling

Cooling for the power module is achieved with two separate cooling loops. The primary cooling loop provides heat rejection for the fuel cell stack and intercooler. Additionally, the primary loop maintains de-ionization of the 50/50 de-ionized water ethylene glycol coolant through use of a mixed bed ion exchange resin. Because overall fuel cell power plant operating efficiency is on the order of 50%, a heat rejection rate of approximately 300 kW must be provided, mostly by the radiators. A 7 kW induction motor (230 VAC) drives a centrifugal pump to provide coolant flow of up to 675 L/min. The pump utilizes closed loop control to maintain a specified difference between the temperatures of the inlet and outlet stack coolant. Maximum operating temperature of the primary coolant loop is 75 C, which is relatively low compared to a pressurized internal-combustion engine system operating at over 100 C.

The secondary cooling loop system provides heat rejection for the air compressor drive motor/controller, fuel cell stack module condenser, DC/DC converter, and oil lube system. Rate of heat rejection is approximately 40 kW, providing coolant to components at 55 C. A centrifugal pump driven by a 1/2 kW motor (24 VDC) provides 80 L/min of coolant at maximum power under maximum ambient conditions.

Because the ability of a radiator to reject heat is proportional to the temperature difference between the coolant and ambient air, the fuel cell cooling system employs a high-efficiency radiator design. The locomotive uses a two-pass cross counter flow arrangement, designed and manufactured by Modine Fuel Cell products group. Unlike a typical multi-pass cross flow automotive radiator, the counter flow arrangement significantly increases the logarithmic mean temperature difference. The heat transfer rate Q between the hot and cold fluids for all single pass radiators is calculated as $Q = AU(LMTD)$, where A is heat transfer area, U is overall heat transfer coefficient, and $LMTD$ is the logarithmic mean temperature difference. Correction factors for multi-pass and cross-flow heat exchangers are then applied to the single-pass heat transfer rate Q . In this locomotive application, the heat exchanger core dimensions are approximately 900 x 1100 mm. In addition to the primary heat exchanger, a radiator for the secondary cooling loop is placed in line with one of the primary radiators to utilize a single air flow path. Each primary heat exchanger is supplied approximately 13,000 CFM of air at maximum operating power at maximum ambient conditions. Air is provided by two 32" fans driven by 15 kW induction motors (230 VAC) at ~1700 rpm. For start up, cool weather operation,

and to regulate stack module inlet temperature, a three-way valve is used to bypass fluid around the primary cooling radiators.

For cold weather protection, the cooling system incorporates a "block heater" with pump that heats and circulates coolant through the primary and secondary cooling loops to prevent stack freezing.

2.4. Hydrogen storage

Hydrogen fuel storage uses readily available hardware and proven safety design measures. Two modules are mounted above the traction battery (see Fig. 6), each consisting of seven carbon fiber/aluminum tanks, measuring 416 mm diameter x 2100 mm length, with a combined storage of 70 kg compressed hydrogen at 350 bar (5100 psi). This storage system provides fuel for a rigorous 8-10 hour switcher duty cycle. Detailed subsystem design and manufacturing of the modules will be executed by Dynetek Industries Ltd.

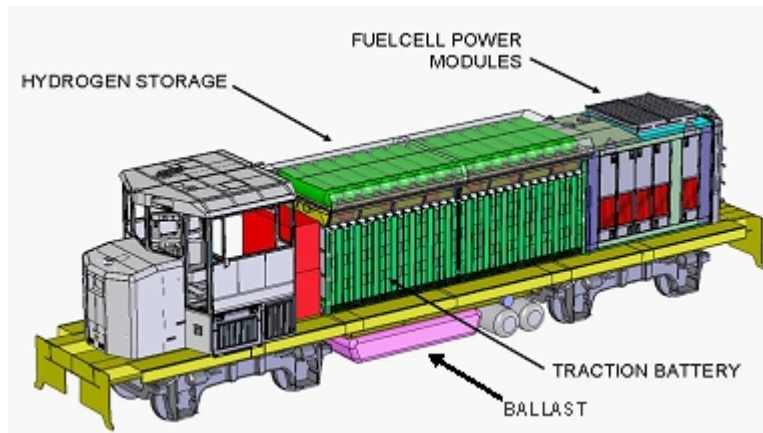

Fig. 6. Compressed hydrogen is stored in fourteen cylinders above the traction battery. A ballast weight will replace the diesel fuel tank to maintain tractive effort and center of gravity.

Each tank incorporates an excess flow valve, two thermally activated pressure relief devices (PRD), temperature sensor, electronically controlled solenoid valve, and manual shut-off valve. In the event of a line rupture between the tank and distribution manifold, the tank excess-flow valve will close. In the event of excessive heat (above 109 C), such as could be caused by a battery fire, the thermally activated PRD's will vent the tank contents through a routed vent line pointing upward and away from the vehicle. The temperature sensors are utilized by the control system to regulate refueling speed as well as indicate any over temperature warnings. The electronic solenoid valve is normally closed, powered open for run and refueling modes, and closed if a high level system fault is detected.

Each module contains a manifold fed by each individual tank. The module manifolds, each with independent pressure sensors, are connected to a primary distribution line that includes an excess-flow valve to control any ruptures in the primary distribution line. The primary distribution line connects to the refueling line, and then continues to a filter, pressure regulator, additional electronic solenoid valve, pressure sensor, and an additional PRD. The additional solenoid valve adds a layer of shutdown capability, while the pressure sensor verifies regulator functionality. As with diesel locomotives, an emergency shutoff device will be located on each side of the vehicle to allow non-operators or refueling personnel to shut down the fuel system.

2.5. Power electronics

In order to effectively use the fuel cell as the prime mover and a battery charging source, the power must be delivered to the locomotive high-voltage bus at the correct power and voltage levels. To do this, a DC/DC boost/buck converter is placed between fuel cell output power and the locomotive high-voltage bus. The system controller receives a power setpoint from the locomotive and in turn controls BOP operation points as well as

the DC/DC converter power output. A transformer in the converter also fully isolates the fuel cell from the high voltage bus.

The fuel cell stacks nominally operate at 600 VDC. In addition to supplying power to the locomotive through the DC/DC converter, the fuel cells must also supply power to all BOP components. The power required to run these components are referred to as "parasitic loads." Depending on the fuel cell type and environmental operating conditions (e.g., ambient air temperature and altitude), parasitic loads can typically range from 20-30%. Voltage and current requirements of the parasitic loads can vary greatly, requiring several different voltage buses as well as DC/AC power conversion. In this locomotive application, the fuel cell power plant uses 600 VDC, 360 VDC, 24 VDC, 12 VDC, and 5 VDC, as well as inverters to provide 230 VAC for both primary coolant pump motor and radiator fan motors. The 600-V bus feeds the traction drive and battery charging, the 360-V bus supplies power for the air compressor motor and inverters, and the 12-V and 24-V buses provide power to valves, actuators, control systems, and sensors. Although power conversion to these various voltages introduces some power losses, in many cases, it is not practical to have components capable of utilizing a single bus due to component cost and/or availability. The power module also incorporates 24 VDC battery backup to ensure constant power to the control system when fuel cell stack power is not available.

2.6. Control

The operation of all fuel cell subsystems must be monitored and coordinated by a central control system, which consists of instrumentation, actuators, motor controllers, and a programmable automation controller (PAC). Several challenges arose when designing the control system for the fuel cell power plant; these include the dependence of vehicle safety on the control system, the sheer number of sensors, controllers, actuators, harsh environmental conditions the control system will be subjected to, and the need for low power consumption. These challenges mandated the following requirements for the PAC, which must (1) be reliable in high vibration and shock situations, (2) operate under a wide temperature range, (3) provide for a large variety of signal conditioning options and actuation, (4) be expandable, and (5) provide for tight control of system operating parameters.

During normal operation, the PAC receives a power setpoint from the locomotive controller via a CAN connection. The PAC relays this power setpoint to the DC/DC converter controller and also establishes the conditions necessary for the fuel cell power plant to generate the requested power. This is accomplished by a combination of open-loop and closed-loop control. First, the mass flow rate of the air needed to produce the requested power is calculated. The air compressor is then controlled to deliver the calculated air mass flow rate. Small corrections to the air mass flow rate are made by measuring the actual air mass flow delivered to the fuel cell. The measured current draw is also used to estimate the amount of cooling needed. Small corrections of the coolant pump speed are made by measuring the coolant temperatures. Assuming sufficient air is provided, the hydrogen supply is dead-ended and consumed at a rate that is proportional to the current drawn from the fuel cells.

The PAC continuously monitors all sensor inputs for abnormal or unsafe conditions in the fuel cell power plant. If an unsafe condition is detected, the appropriate action is taken. In most cases, this results in a power output reduction but could cause a fuel cell power plant shutdown. The status of the fuel cell power plant is summarized on the user-

interface display, including the presence of any system faults. Key fault conditions are also transmitted to the locomotive controller via the CAN connection.

2.7 Mounting and Isolation

Mounting of all fuel cell system modules to the locomotive is of critical importance. Because switcher locomotives are used to move other cars in rail yards, they are constantly coupling to other cars, which can lead to shock loads up to 10 Gs (11 ms saw tooth). Although they are of short duration, shocks of this magnitude could lead to immediate or fatigued failure of components or mounting structures. To mitigate this harsh environment, each module must be isolated from the impact loads; this is effectively done through the use of springs, specifically rubber or synthetic mounts or isolators. Three key factors are involved in choosing the proper isolator to deal with the impact forces. First, the isolator must absorb enough energy to make the loads experienced by the components within acceptable limits, i.e., it must reduce shock loads from 10 G to no more than 3 G. Second, the isolator must absorb this energy through a deflection distance that is acceptable from a physical packaging and system interface standpoint. For example, if a particular isolation

mount requires 30 mm of movement to absorb the required energy, this may be too much movement for the coolant hose that is connected to the particular component. Finally, the mounts' natural frequency should be well below the possible disturbing frequencies of the system. The isolation system must also provide proper shock protection in the horizontal, lateral, and vertical directions. Figure 7 shows the isolation system for the power plant. Note that the mounting system is designed so that it is at the vertical center of gravity, which will minimize any rocking motion of the power plant and

transmit force directly into the mounts. In addition to careful selection of isolation mounts, finite element analysis was used to validate all structural weldment designs.

3.0. Conclusions

The experience of Vehicle Projects LLC in designing and developing the largest fuel cell land vehicle to-date shows that vehicle scale-up by increasing mass, density, or power presents new technical design and development challenges. These relate primarily to issues of system layout, hydrogen storage, heat transfer, and shock loads. While these challenges are by no means insurmountable, they should be anticipated when a design process commences.

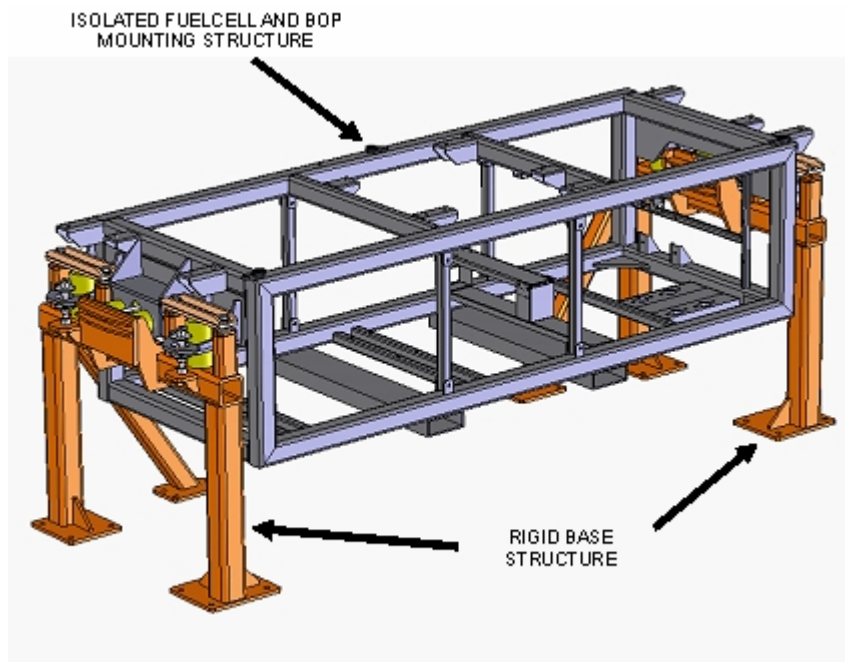

Fig. 7. All fuel cell stacks and balance of plant components mount to an isolated structure. The isolated structure provides protection during the harsh duty of the switcher locomotive.

Acknowledgements

We thank the following funders for their generous support of the projects described in this paper: US Department of Energy (contracts DE-FC36-99GO10458, DE-FC26-01NT41052, DE-FC36-01GO11095, and DE-FC36-05GO85049); Natural Resources Canada (Emerging Technologies Program contracts 23440-991022-001 and EA9730-F01-01); Government of Canada (Action Plan 2000 on Climate Change contract 23440-0310202-001); US Department of Defense (contracts F42620-00-D0036 and F42620-00-D0028); BNSF Railway Company; subcontractors to Vehicle Projects LLC who contributed project cost-share; and the Fuelcell Propulsion Institute. *Disclaimer:* Funding support from the US Department of Energy, US Department of Defense, Natural Resources Canada, Government of Canada, or BNSF Railway Company does not constitute an endorsement by same of the views expressed in this paper. Some results reported in this paper were presented orally at the ASME Fifth International Fuel Cell Science, Engineering & Technology Conference.

References

- [1] A.R. Miller, "Tunneling and Mining Applications of Fuelcell Vehicles," Fuel Cells Bulletin, May 2000.
- [2] A.R. Miller and D. L. Barnes, "Fuel Cell Locomotives," Proceedings of Fuel Cell World, Lucerne, Switzerland, 1-5 July 2002.
- [3] A.R. Miller, D.L. Barnes, B.D. Hoff, O.A. Velev, L. Sheppard, P. Chintawar, and M. Golben, "Fuelcell-Battery Hybrid Mine Loader," Proceedings of 2004 Fuel Cell Seminar, San Antonio, USA, 1-5 November 2004.
- [4] A.R. Miller, D.H. DaCosta, and M. Golben, "Reversible Metal-Hydride Storage for a Fuelcell Mine Loader," Proceedings of the Intertech-Pira Conference 2006 Hydrogen and Storage Forum, Vancouver, Canada, 11-13 September 2006.
- [5] A. R. Miller, J. Peters, B. E. Smith, and O. A. Velev, "Analysis of Fuelcell Hybrid Locomotives," Journal of Power Sources, 157 (2006) 855-861.
- [6] Ballard Power Systems, 2007. See <http://www.ballard.com>.