

# ADVANCED GPS-BASED TIME LINK CALIBRATION WITH PTB'S NEW GPS CALIBRATION SETUP

**Thorsten Feldmann**  
**Physikalisch-Technische Bundesanstalt (PTB)**  
**Bundesallee 100, 38116 Braunschweig, Germany**  
**E-mail: *thorsten.feldmann@ptb.de***

**Andreas Bauch<sup>1</sup>, Dirk Piester<sup>1</sup>, Michael Rost<sup>1</sup>,  
Elizabeth Goldberg<sup>2</sup>, Stephen Mitchell<sup>2</sup>, and Blair Fonville<sup>2</sup>**

**<sup>1</sup> Physikalisch-Technische Bundesanstalt (PTB)**  
**<sup>2</sup> U.S. Naval Observatory (USNO)**

## Abstract

*The PTB has assembled an easy-to-use GPS calibration set-up intended for relative time link calibrations, consisting of a GTR50 time and frequency GPS receiver and an SR620 time-interval counter integrated in a small rack together with a monitor and a keyboard.*

*Usually, locally available time interval counters are used to measure the offset  $\delta_0$  between the 1 PPS signal representing the local time scale and the signal that is connected to the traveling receiver in each visited laboratory. In each time-interval counter, a distinct error for time-interval measurement shows up. If only one single counter is used at all participating laboratories, this error cancels out, assuming that the properties of this counter do not change during the travel, as it is assumed for the properties of the traveling receiver as well.*

*The calibration setup was shipped to USNO in mid June 2010 and was used to calibrate the time transfer links between USNO and PTB, in total 16. This large number reflects the multitude of fixed receivers involved and the different kinds of data processing. For all cases, the calibration uncertainty is at the level of 2 ns and below. The results have been used to validate an ad-hoc calibration adjustment made earlier by the BIPM to the Ku-band TWSTFT link. A deviation of 3.7 ns compared to the 2008 result was found.*

## INTRODUCTION

UTC generation and dissemination is one of the tasks of the BIPM Time, Frequency, and Gravimetry Department. It is comprised of the computation of UTC-UTC (k) and the estimation of its uncertainty, which is related to the knowledge of the internal delays in the time transfer equipment involved. Organizing and maintaining the calibration of this equipment is also among the responsibilities of the BIPM, but part of the work has been delegated to the Regional Metrology Organizations such as EURAMET. In view of this, PTB has assembled an easy-to-use GPS calibration setup.

## Report Documentation Page

*Form Approved*  
*OMB No. 0704-0188*

Public reporting burden for the collection of information is estimated to average 1 hour per response, including the time for reviewing instructions, searching existing data sources, gathering and maintaining the data needed, and completing and reviewing the collection of information. Send comments regarding this burden estimate or any other aspect of this collection of information, including suggestions for reducing this burden, to Washington Headquarters Services, Directorate for Information Operations and Reports, 1215 Jefferson Davis Highway, Suite 1204, Arlington VA 22202-4302. Respondents should be aware that notwithstanding any other provision of law, no person shall be subject to a penalty for failing to comply with a collection of information if it does not display a currently valid OMB control number.

1. REPORT DATE <b>2010</b>		2. REPORT TYPE		3. DATES COVERED <b>00-00-2010 to 00-00-2010</b>	
4. TITLE AND SUBTITLE <b>Advanced GPS-Based Time Link Calibration With PTB's New GPS Calibration Setup</b>				5a. CONTRACT NUMBER	
				5b. GRANT NUMBER	
				5c. PROGRAM ELEMENT NUMBER	
6. AUTHOR(S)				5d. PROJECT NUMBER	
				5e. TASK NUMBER	
				5f. WORK UNIT NUMBER	
7. PERFORMING ORGANIZATION NAME(S) AND ADDRESS(ES) <b>U.S. Naval Observatory, 3450 Massachusetts Avenue, N.W., Washington, DC, 20392</b>				8. PERFORMING ORGANIZATION REPORT NUMBER	
9. SPONSORING/MONITORING AGENCY NAME(S) AND ADDRESS(ES)				10. SPONSOR/MONITOR'S ACRONYM(S)	
				11. SPONSOR/MONITOR'S REPORT NUMBER(S)	
12. DISTRIBUTION/AVAILABILITY STATEMENT <b>Approved for public release; distribution unlimited</b>					
13. SUPPLEMENTARY NOTES <b>PTTI proceedings 2010, pages 509-526</b>					
14. ABSTRACT <b>The PTB has assembled an easy-to-use GPS calibration set-up intended for relative time link calibrations, consisting of a GTR50 time and frequency GPS receiver and a SR620 time interval counter integrated in a small rack together with a monitor and a keyboard. Usually locally available time interval counters are used to measure the offset dt0 between the 1 PPS signal representing the local time scale and the signal that is connected to the traveling receiver in each visited laboratory. In each time interval counter a distinct error for time interval measurement shows up. If only one single counter is used at all participating laboratories this error cancels out, assuming that the properties of this counter do not change during the travel, as it is assumed for the properties of the traveling receiver as well. The calibration set-up was shipped to USNO in mid June 2010 and was used to calibrate the time transfer links between USNO and PTB, in total 16. This large number reflects the multitude of fixed receivers involved and the different kinds of data processing. For all cases the calibration uncertainty is at the level of 2 ns and below. The results have been used to validate an ad-hoc calibration adjustment made earlier by the BIPM to the Ku-band TWSTFT link. A deviation of 3.7 ns compared to the 2008 result was found.</b>					
15. SUBJECT TERMS					
16. SECURITY CLASSIFICATION OF:			17. LIMITATION OF ABSTRACT	18. NUMBER OF PAGES	19a. NAME OF RESPONSIBLE PERSON
a. REPORT <b>unclassified</b>	b. ABSTRACT <b>unclassified</b>	c. THIS PAGE <b>unclassified</b>			

In relative calibration campaigns, the offset  $\delta t_0$  between the 1 PPS signal representing the local realization of UTC that is connected to the traveling receiver and the local UTC reference point has to be measured in each laboratory. Usually time-interval counters are used for that purpose. Unfortunately, the internal delays between their two input channels vary from unit to unit. If a time-interval counter (TIC) is shipped together with the receiver and  $\delta t_0$  is measured using exactly this device at all participating laboratories, the overall uncertainty would be reduced. If the properties of this counter do not change during the travel, the uncertainties associated with the use of different TICs at each site will be avoided. For this purpose, PTB has integrated a GTR50 time and frequency GPS receiver and an SR620 TIC together with a monitor and a keyboard in a small transportable rack. The measured offset  $\delta t_0$  is automatically applied to the GPS data by the software that controls the complete calibration procedure.

The calibration setup was used to calibrate the time links between USNO and PTB in the same way as it was done in previous campaigns involving ROA [1] and METAS [2]. The calibration setup was put into operation at PTB in the beginning of June 2010. After having collected enough data for the computation of the common-clock difference (CCD), it was shipped to USNO in mid June 2010. There, it was operated by the local staff and data were collected in July 2010. A second closure measurement was conducted at PTB in September 2010 after the calibration setup had been shipped back.

First, we briefly review the differential GPS link calibration procedure. Then we give an introduction to PTB's new calibration setup. Finally, we present the results of the USNO-PTB calibration campaign.

In the past, the time link between USNO and PTB stood out against other transatlantic links. In addition to GPS-based time transfer, two independent links through Two-Way Satellite Time and Frequency Transfer (TWSTFT) were in operation, with signals exchanged in X-band and in Ku-band, respectively. The links were repeatedly calibrated using a fly-away X-band TWSTFT terminal [3]. Thus, the current campaign can be considered as a recalibration of the TWSTFT time link and of the standard GPS link both used by the BIPM. In view of this, the uncertainty estimation is discussed in detail.

## DESCRIPTION OF THE CALIBRATION PROCEDURE

In a relative GPS link calibration campaign between two timing laboratories LAB1 and LAB2, a traveling receiver (TR) is first operated at LAB1 together with all the fixed GPS receivers in a common-clock, very-short-baseline (a few meters distance between the antennas) setup for several days. Then it is shipped to LAB2 together with its antenna and antenna cable and operated there again for several days in a very-short-baseline setup together with the equipment in LAB2. In order to ensure that the internal delays have not changed during the travel, the measurement at LAB1 is repeated after the TR was shipped back to LAB1.

As depicted in Figure 1, the devices are connected to the local UTC realization by 1 PPS signals with offsets relative to the local UTC reference point. Figure 1 shows the setup at two labs operating GPS as well as TWSTFT equipment. FR denotes all fixed GPS receivers at LAB1 and LAB2, respectively.

Normally, at the fixed equipment, the 1 PPS signal delays with respect to the local reference points are known with a low uncertainty, as well as equipment internal delays and antenna cable delays. However, in terms of a relative calibration, these delays do not have to be taken into account, if the goal is to calibrate the entire link, including the complete chain of signal distribution, cables, and antennas in both laboratories. The only important value is the offset  $\delta t_0$  of the temporary connection between the TR and the local reference point in both labs. It should be measured as accurately as possible.

To ensure that potential short-term variations average out in the common-clock difference (CCD) between the TR and the FRs, the TR should be operated at least 1 week in each laboratory. The CCD values then represent the difference of the sums of the delays in the antenna, antenna cable, receiver, and connection to the reference point.

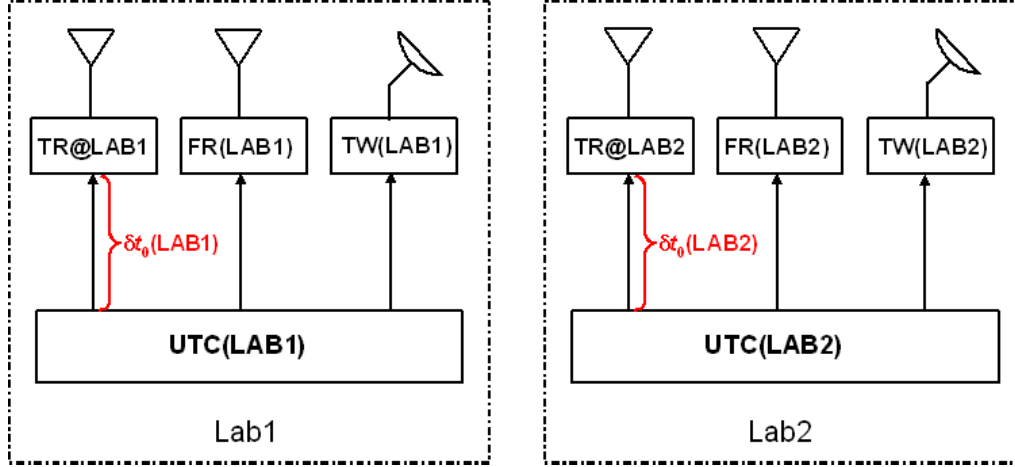

Figure 1. Schematic of the link calibration setup at two labs equipped with GPS and TWSTFT.

By differencing the CCD results of both labs, the contributions of the TR cancel out and we get the calibration value for the links between FRs (one pair or multiple combinations). This statement is valid to the extent that the properties of the TR are unchanged during the campaign. In mathematical terms, it reads as follows:

$$\langle \text{TR@LAB1} - \text{FR(LAB1)} \rangle - \langle \text{TR@LAB2} - \text{FR(LAB2)} \rangle = C_1 - C_2 = C_{\text{GPS}}, \quad (1)$$

where  $\langle \dots \rangle$  stands for the mean value of measurements over a certain period. We note that the sign of the calibration value  $C_{\text{GPS}}$  is arbitrarily defined by (1). With this convention, the results of comparisons between the two UTC realizations UTC(LAB2) and UTC(LAB1) have to be corrected according to

$$[\text{UTC(LAB2)} - \text{UTC(LAB1)}]_{\text{GPS}} = \text{FR(LAB2)} - \text{FR(LAB1)} - C_{\text{GPS}}. \quad (2)$$

We use the mean of both CCDs at LAB1 before and after the trip to LAB2 to calculate the value  $C_1$  in order to include small changes of the TR's internal delays in the uncertainty estimation. The difference between the two CCDs obtained in LAB1 is then part of the uncertainty budget, which is explained later.

If the two labs maintain a TWSTFT link, as shown in Figure 1, a calibration value for the TWSTFT link can be calculated by comparing it to the calibrated GPS link:

$$\langle [\text{UTC(LAB2)} - \text{UTC(LAB1)}]_{\text{GPS}} - [\text{UTC(LAB2)} - \text{UTC(LAB1)}]_{\text{TWSTFT}} \rangle = C_{\text{TWSTFT}}. \quad (3)$$

## PTB'S NEW CALIBRATION SETUP

To measure the offset  $\delta t_0$  between the local UTC reference point and the 1 PPS signal connected to the TR, usually a time-interval counter (TIC) is used at each lab. The delay between the start and stop channels of different TICs are unequal, also for TICs of the same type. The time-interval measurement with the Stanford Research System SR620 TIC, which is well known and extensively used in the timing community, is affected by a systematic error of 500 ps, according to the manufacturer's specifications. This error would have to be considered in the uncertainty budget.

To reduce the overall uncertainty of a relative link calibration, a traveling TIC can be shipped together with the receiver, and  $\delta t_0$  would then be measured using exactly this device at all participating laboratories involved in the calibration campaign. The systematic error of the travelling TIC cancels out as well as the delays related to the TR. In order to accomplish this, PTB has integrated a GTR50 time and frequency transfer GPS receiver with an SR620 TIC in a small transportable rack together with a monitor and a keyboard (Figure 2). This new calibration station was used to calibrate the links between PTB and USNO in 2010.

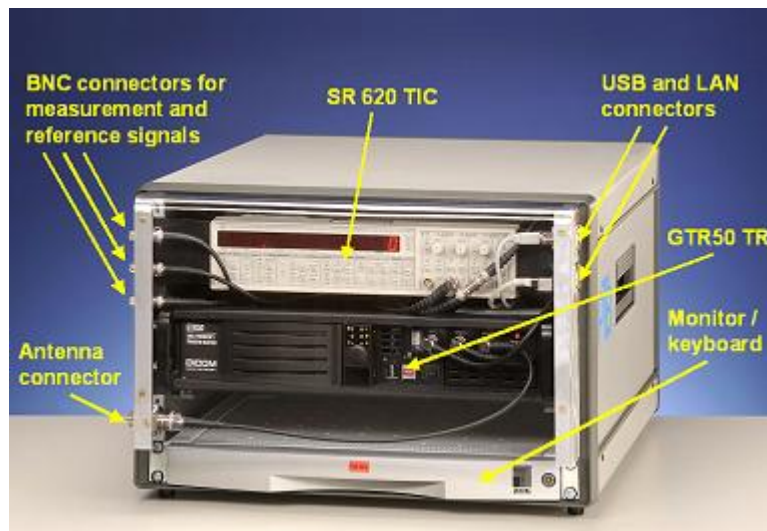

Figure 2. Front view of the calibration setup.

Beyond the reduction of the uncertainty, the new calibration setup offers further advantages, because it is easy to use for the local staff at the involved laboratories due to a text-based software that controls the complete calibration procedure, including the TIC measurement as well as the GPS measurement, and thus minimizes the risk of unintended errors. Furthermore, the remote labs neither need to allocate additional equipment like keyboards and monitor for the control of the TR nor to care about documentation of the TIC measurement and its uncertainty.

Figure 2 shows the front side of the calibration setup. All connectors are easily accessible along the side, except the connection for power supply, which is located on the rear side. This avoids cable mess in the laboratory. The LAN connector is only designated for maintenance purposes at PTB and is deactivated in the remote labs.

In Figure 3, on the left the signal connectors are visible, and on the right the cable layout plan inside the

rack is depicted.

At the REF IN connector, the setup is provided with a 5 MHz or 10 MHz external reference frequency. This frequency need not to be the local UTC frequency and can be derived from any atomic standard, because it is just the reference for the SR620 TIC. The GTR50 compares an external 1 PPS signals to a 1 PPS generated by its receiver board, which is synchronized to the GPS system time and applies this value to the output CGGTTS and RINEX data. Detailed descriptions of the GTR50 receiver can be found, for example, in [4,5].

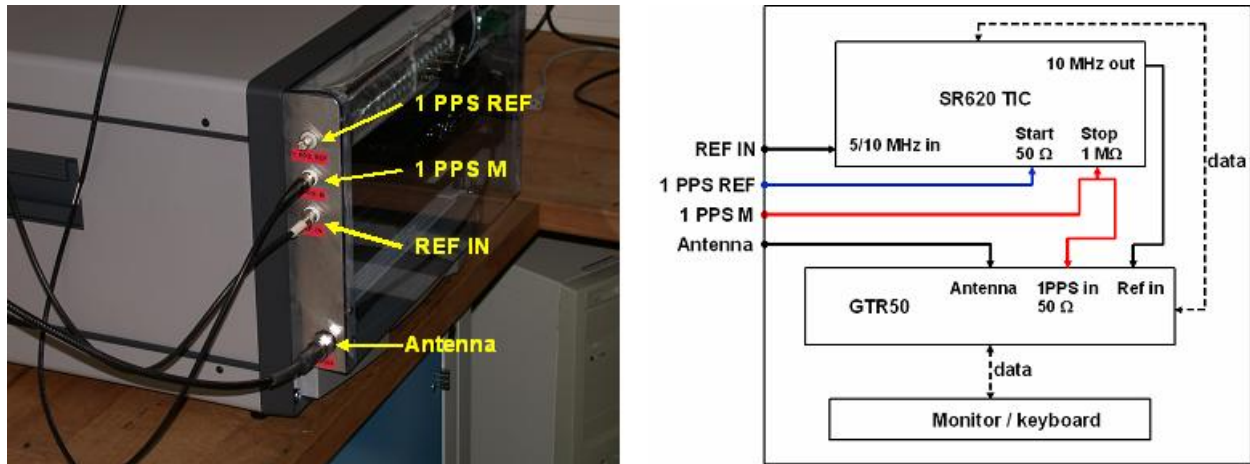

Figure 3. Signal connectors (left picture) and internal cable layout (right picture).

The 1 PPS M connector provides the receiver with the local 1 PPS UTC signal. The offset of this signal with respect to the local UTC is measured by the TIC before the GPS measurement starts. For this purpose, a 1 PPS signal with known delay to UTC has to be connected to the 1 PPS REF connector. The software can be configured in such a way that a cable representing the local UTC with a known uncertainty at its connector is permanently used at 1 PPS M without the delay measurement being made.

The delay induced by the internal cables, labeled red and blue in Figure 3, cancels out in (2). In case a laboratory wishes to use the TR's measurement data for an absolute calibration of its receivers, this delay could be measured with a TIC and applied to the internal software. However, the uncertainty of such corrections would be more than 500 ps due to the specifications of the TIC. A verification of the absolute calibration of the TR implemented in the calibration setup can be found in [6].

## MEASUREMENT PROCEDURE AT A REMOTE LABORATORY

After setting up the calibration setup in the laboratory's measurement room and connecting it to the power supply, the operating system of the TR boots up and the calibration software starts automatically without asking for a username or password. The required AC input voltage is adjusted before leaving PTB to the anticipated conditions abroad. In Figure 4 (left picture), the calibration setup with pulled-out monitor and keyboard is shown.

The first program screen requests the user to wait until the internal SR620 TIC is warmed up. The right plot in Figure 4 shows that the TIC needs approximately 1 hour to reach a stable state after turning on.

For this test, we have provided the same 1 PPS signal to both the start and stop channel by using a power splitter and cables of arbitrary lengths. To ensure that the TIC is in the stable state in any case under the unknown environmental conditions in a remote lab, the waiting time is set to 2 hours. The remaining time is displayed on the monitor. Of course, it is possible to exit the program and to shut down the system during the warm-up period, as it is also possible in all following program steps, but then the warm-up time is reset to 2 hours, even though the device is immediately restarted.

After the warm-up period, the operator is asked for the precise antenna position in ITRF Cartesian coordinates. This information is needed by the TR's internal processing software to generate the CCGTTS C/A code and L3P files correctly. If the antenna position is unknown in a remote lab, an arrangement could be made with this lab to modify the software in order to enable collecting RINEX data for 1 or 2 days, to send it to PTB, and to input the position later after estimating it from the RINEX data using the precise point positioning method (PPP) [7] at PTB.

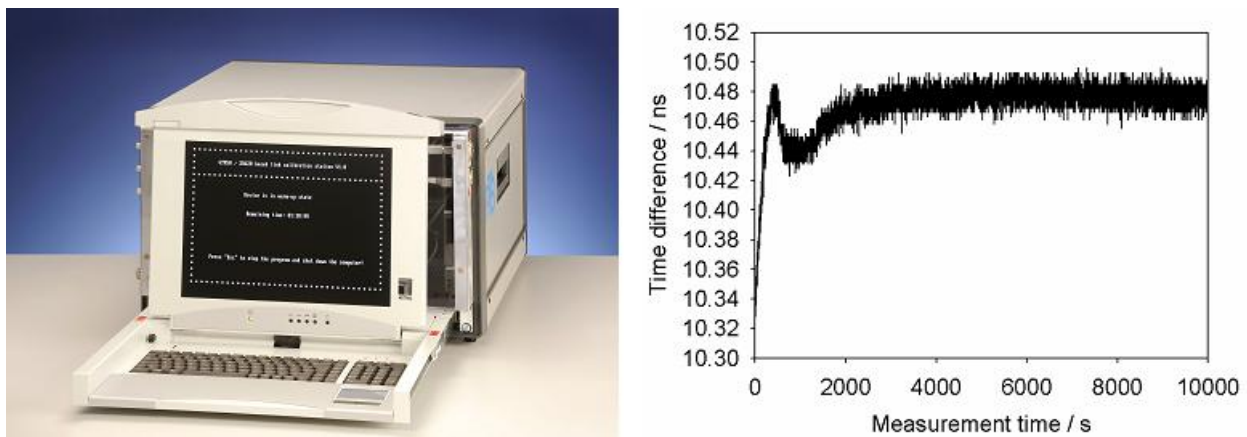

Figure 4. The calibration setup with pulled-out monitor and keyboard (left) and warm-up characteristics of the internal SR620 TIC (right).

The next step is to input the acronym of the laboratory, so that confusion with the measurement data is impossible. Then the reference frequency at the REF IN connector and the measurement 1 PPS at the 1 PPS M connector are checked. It is impossible to proceed with the procedure until both signals are correctly detected by the TIC. The operator has to decide whether the reference frequency is 5 MHz or 10 MHz. Normally, a trigger level of 1 V is used for the 1 PPS M signal, but if arrangements are made with the remote lab, this level can be changed between 0 V and 2 V. This level is then used by the TIC as well as by the TR.

If the reference and measurement signals are correctly connected and the adjustment is finished, the local UTC reference signal has to be connected to 1 PPS REF. Here, it is also possible to change the trigger level that is used by the TIC. If a reference cable with measured offset to the local UTC is needed, it should be used at the same trigger level as was used to determine this offset. Otherwise, it should also be 1 V. The software also asks for the delay of the reference signal and its uncertainty, if there is any.

After this, the SR620 TIC automatically starts to measure the delay between 1 PPS REF and 1 PPS M. The software takes 100 single measurements and calculates the mean value, the jitter, and the rate. The measurement can be repeated in case of problems with the signals, e.g. if a significantly high jitter or rate is observed (Figure 5). The measured delay of the reference signal and the internal cable delay are

applied to the measurement values by the software.

The reference cable can be removed after the delay measurement and used for other purposes in the lab. The mean measurement result is used in the TR's software and applied to the CGGTTS and to the RINEX data.

Due to the internal TIC used inside the GTR50, no additional measurements are needed. The internal temperature stabilization inside the GTR50 needs about 20 minutes to warm up the receiver board and the TIC card to 45°C [4]. Then the receiver starts to collect the first measurement data. At the end, after about one week taking GPS measurement data, the reference delay measurement can be repeated to check the stability of the environmental conditions in the lab.

```

*****
*
*          GTR50 / SR620 based link calibration station V1.0
*
*****
*
*          Averaging 100 measurements:
*
* 91:      22.926 ns      Mean:      22.936 ns
* 92:      22.937 ns
* 93:      22.937 ns      Jitter:    0.004 ns
* 94:      22.934 ns
* 95:      22.934 ns      Rate:     0.000 ns/s
* 96:      22.934 ns
* 97:      22.931 ns
* 98:      22.948 ns      Press "s" to start the GPS measurement
* 99:      22.934 ns
* 100:     22.934 ns      Press "r" to repeat the delay measurement
*
*
*
*****

```

Figure 5. The calibration software's screen after the reference delay measurement.

## CALIBRATION OF THE TIME LINKS BETWEEN USNO AND PTB

In June 2010, the calibration setup was operated at PTB for 9 days between MJD 55350 and MJD 55358. Then it was shipped to USNO and operated there for 12 days within the interval MJD 55400 to MJD 55411 in July and August 2010. After it was sent back, the second operation at PTB was done between MJD 55448 MJD 55456 in August 2010.

Table 1 specifies the types of receivers involved at PTB and USNO and the related data output. The nomenclature is according to the conventions used on the BIPM data server (C/A, P3, RINEX) and by the IGS tracking network (RINEX), respectively, if the data are provided to these institutes. Otherwise, the name used by the receiver software that produces the files is used. An exception is the TTS-3 receiver: Since this receiver outputs both C/A code and P3 code measurements in one file, we followed a PTB internal convention for better distinction as in previous campaigns [1,2]. The TTS-3 RINEX data were found not to be useful for the purpose here [2].

In the following, we will refer to the nomenclature of fixed receivers (FR), as given in Table 1, which takes into account that one receiver produces different kinds of data.



Table 1. Receivers at PTB and USNO and their designation when providing data of different kind.

Institute	Receiver	C/A	P3	RINEX
PTB	Ashtech Z12-T	---	PT02	PTBB
	Ashtech Z12-T	---	PT03	PTBG
	AOS TTS-3	PT05	PT06	---
USNO	Ashtech Z12-T	---	USNO	USNO
	AOS TTS-2	US01	---	---
	Ashtech Z12-T	---	US03	USN3
	NovAtel ProPak	---	NOV1	NOV1

As Table 1 shows, nine P3 links, six combined code and carrier-phase links using the PPP method [7], and one C/A code link can be evaluated.

### UNCERTAINTY ESTIMATION

The overall uncertainty of the GPS link calibration is given by

$$U = \sqrt{u_a^2 + u_b^2}. \quad (4)$$

In order to get the statistical uncertainty  $u_a$ , we first calculate the time deviation (TDEV) of all CCD measurements at USNO and at PTB before and after the trip to USNO. From the minimum of the log plot of the TDEV, we estimate the period we can use to average the data. Then we calculate the mean value and the standard deviation (SD) of the averaged data. At USNO, the SD is directly the relevant  $u_a$ -contribution. Since CCD data were taken at PTB before and after the trip to USNO, we choose the higher SD as the relevant contribution. If the difference of the mean values of the two CCD measurements (dCCD) is smaller than this SD, the SD is taken as the uncertainty contribution. Otherwise, the absolute value of dCCD is used, because equipment delay changes apparently exceed the other noise components. The contributions of USNO and PTB are added in quadrature.

The systematic uncertainty is given by

$$u_b = \sqrt{\sum_n u_{b,n}^2} \quad (5)$$

and explained in detail in Table 2 and the text below.

The TIC measurement was repeated at PTB after each CCD measurement and at USNO after the CCD measurement, so we got four measurements at PTB and two at USNO. Only the measurement before each CCD was used. The second one was used for control only. The jitter values are included in the uncertainty estimation ( $u_{b,5}$ ,  $u_{b,6}$ ). The difference between the TIC measurements before and after collecting CCD data did not exceed 0.05 ns, which supports the estimate of a 0.1 ns uncertainty of the connection to the local UTC at both sites ( $u_{b,1}$ ,  $u_{b,2}$ ) [2]. The significantly higher jitter at USNO is due to the fact that the 1 PPS M signal appeared before the 1 PPS REF signal. The TIC measurements (1 PPS REF -1 PPS M) become more noisy for such long time intervals (approaching 1 s).

Table 2. Systematic uncertainty contributions. Values are determined either by measurements or by estimation and rounded to the second decimal. The contributions marked with an asterisk are only applied to special measurements (see text).

Uncertainty	Value / ns	Description
$u_{b,1}$	0.10	Instability of the connection to UTC(PTB)
$u_{b,2}$	0.10	Instability of the connection to UTC(USNO)
$u_{b,3}$	0.06	TIC trigger level timing error at PTB [8]
$u_{b,4}$	0.06	TIC trigger level timing error at USNO [8]
$u_{b,5}$	0.01	Jitter of the TIC after 100 measurements at PTB
$u_{b,6}$	0.05	Jitter of the TIC after 100 measurements at USNO
$u_{b,7}$	0.02	TR trigger level timing error at PTB [9]
$u_{b,8}$	0.02	TR trigger level timing error at USNO [9]
$u_{b,9}$	0.10	TIC nonlinearities PTB
$u_{b,10}$	0.10	TIC nonlinearities USNO
$u_{b,11}$	0.02	Determination of the UTC reference point at PTB
$u_{b,12}$	0.30	Multipath [11]
$u_{b,13}$	0.18	Antenna cable and antenna [4]
$u_{b,14}^*$	0.26	Position error at PTB
$u_{b,15}^*$	0.30	Position error at USNO
$u_{b,16}^*$	0.30	Uncertainty of the ambiguity estimation [12]

In a previous study during which different TICs were used, the uncertainty of the TICs was accounted for by 0.5 ns [2]. The error of the TR's internal TIC was neglected. Since the same TIC is used in both labs here, the systematic uncertainty of the TIC cancels out. The remaining part is the trigger level timing error ( $u_{b,3}$ ,  $u_{b,4}$ ), given by

$$\text{Trigger level timing error} = \frac{15 \text{ mV} + 0.5\% \text{ of trigger level}}{1 \text{ PPS slew rate}} \quad (6)$$

for start and stop channel, respectively, according to the manufacturer specifications [8]. With a trigger level of 1 V at one channel and an estimated signal slew rate of 0.5 V/ns, the error is 0.04 ns per channel and 0.06 ns for the measurement after adding the start and stop error in quadrature. The trigger level timing error of the TR's internal TIC ( $u_{b,7}$ ,  $u_{b,8}$ ) is estimated, according to information given by the manufacturer [9], as 10 mV / (1 PPS slew rate) per channel. The error of the stop channel cancels out, because it is always provided with the signal of the receiver board.

The uncertainty contributions  $u_{b,9}$  and  $u_{b,10}$  are related to nonlinearities in the TIC in conjunction with the external reference frequency. We connected the traveling TIC to frequencies generated by different clocks at PTB (masers, commercial cesium clocks) and used 5 MHz and 10 MHz, respectively, while the start and stop channel were provided with 1 PPS signals of one clock, as in the 1 PPS REF - 1 PPS M measurements. We also changed the length of the reference cable. After averaging 50 single measurements in each setup, we found that slightly different results were obtained, but the difference was always below 0.1 ns. We verified the results by repeating all measurements with other TICs available at PTB. This effect has not yet been studied in detail, but we suppose that it is related to interpolation processes in the TIC. We account for it by 0.1 ns at each laboratory.

The TR's internal TIC uses a surface acoustic wave (SAW) filter as interpolator, similar to the TIC analyzed in [10], but with less precision [9]. For TICs based on this principle, the nonlinearity effect is negligible, because it is of the order of magnitude of a few ps [9,10].

In contrast to USNO, where the local UTC is defined at the endpoints of female BNC connectors, a reference cable with a male BNC connector is used at PTB. The delay of this cable with respect to UTC (PTB) was checked before the TIC measurement. In order to get equal conditions at USNO and PTB, an additional reference cable was used to connect the USNO local reference points to the calibration setup. At PTB, this cable was interconnected between the setup and the fixed reference cable using a male-to-male BNC adapter. At USNO, this cable was used to establish the connection between the reference point and the setup. Its delay cancels out in (3). The checking of PTB's fixed reference cable and the estimation of the delay of the adapter yield the uncertainty  $u_{b,11}$ .

In the case of a GPS link calibration, the propagation of the satellite signals is only affected by multipath effects [11] ( $u_{b,12}$ ), because in a quasi-zero-baseline setup, in which the CCDs are measured, the atmospheric and site-dependent effects like displacement of the solid earth by the tidal potential of the moon can be neglected.

We cannot assume that the average outside temperature at PTB and USNO was the same for the three measurement periods, and thus the length of the antenna cable of the TR and the electrical delay of the antenna was not exactly the same. We assume a maximum difference between the CCD measurements of 20°C. The cable we used is a FSJ1 cable with an approximate electrical delay of 224 ns. The cable manufacturer indicates a value of 400 parts per million (ppm) for the electrical delay change per degree. Thus, we would get 0.09 ns. The temperature sensitivity of the NovAtel GPS 702GG antenna is unknown. Therefore, we use a temperature coefficient of 0.01 ns/°C for the complete system cable and antenna according to CCD measurements performed at ROA in 2008 between two GTR50 receivers connected to the same type of antenna with cables of comparable lengths [4]. The uncertainty contribution  $u_{b,13}$  is accounted for by 0.18 ns. An evaluation of the temperature sensitivity using the code-phase residuals according to [13] is not possible for the GTR50 receiver, since the 1 PPS signal measured by the internal TIC versus the external 1 PPS is derived from the code. This measurement is applied to all data. Hence, the temperature sensitivity of the code is transferred to the phase data.

For the generation of the CGGTTS data, the TR's position is entered into the processing software manually before the measurement. We have compared two FRs at PTB and two FRs at USNO with CGGTTS P3 data generated from RINEX files using the RINEX-CGGTTS conversion software developed at ORB [14] and shifted fictitiously the position of one of the two receivers at each lab by steps of several centimeters up to 30 m in latitude, longitude, and height from the original position. We found that the time error is linear, dominating in the height, and can be estimated as  $e_h(\text{USNO}) = 2.13 \text{ ns/m}$  at USNO and  $e_h(\text{PTB}) = 2.22 \text{ ns/m}$  at PTB. Thus, we use the absolute value of the difference between the "true" position and the manually entered position and multiply it with  $e_h(\text{USNO})$  and  $e_h(\text{PTB})$ , respectively, to get  $u_{b,14}$  and  $u_{b,15}$ . The "true" position is taken from the position estimates of the NRCan-PPP software [7] during the calibration campaign. The position error of the FRs is not matter of the relative calibration campaign. A wrong FR position leads to errors related to the troposphere estimation (and ionosphere estimation, if C/A code is used) and increases the noise level, but the offset introduced to the data becomes part of the calibration value.

An additional uncertainty contribution  $u_{b,16}$  of 0.3 ns is applied to all PPP calibrations, because the initial phase of the carrier frequency is *a priori* unknown and has to be estimated by the PPP software from the P3 code [12]. In [12], a typical phase discontinuity of 0.15 ns per receiver was found for PPP batch processing with the NRCan-PPP software [7], independent of the length of the processed batch. This

adds up geometrically to 0.21 ns for a CCD comparison between a pair of receivers and to 0.3 ns for the two CCD measurements at USNO and PTB.

In contrast to a previous study [2], we have not applied a special uncertainty contribution related to phase drifts of the Ashtech Z12-T receivers, because in the meantime we found indications that the performance of this receiver type could be different in various laboratories.

## RESULTS

Figure 6 shows the CCD measurements at PTB. For better visibility, offsets have been introduced to some of the data. The code-based CCDs are evaluated with the common-view (CV) method. One result of study [2] was that the values obtained with CV are valid for links evaluated with CV as well as for links evaluated with the all-in-view (AV) method, due to the quasi-zero-baseline setup, but CV results are less noisy.

For the evaluation of the carrier phase, the NRCan-PPP software [7] was used with IGS satellite clock and ephemeris data built in. Corrections for the antenna phase center were applied according to the IGS.

In Figure 7, the CCD measurements at USNO are depicted. Figure 8 shows exemplarily the TDEV of the USNO measurements to clarify how this function is used to estimate the best averaging period.

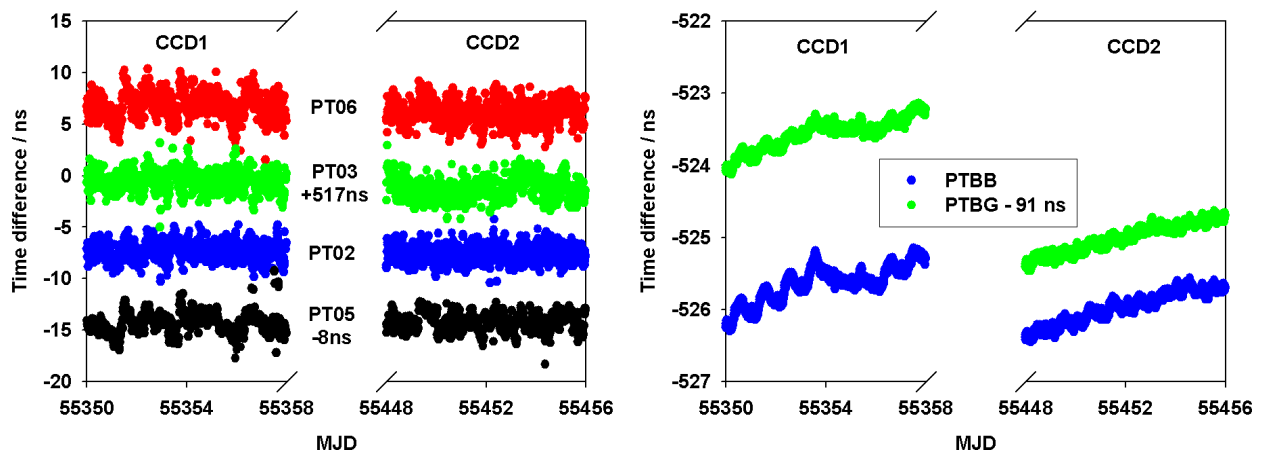

Figure 6. Code (left) and PPP (right) CCD measurement at PTB before and after the calibration trip to USNO.

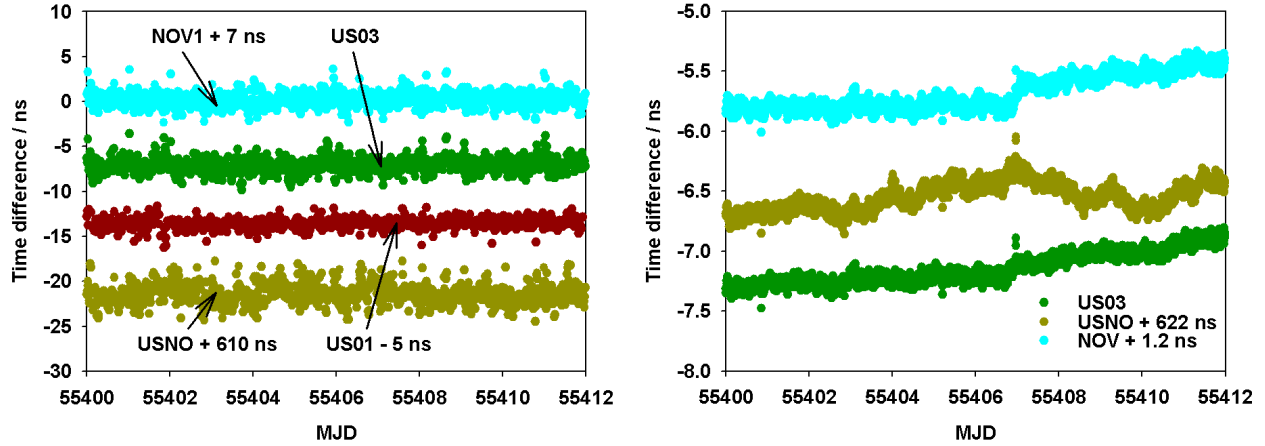

Figure 7. Code (left) and PPP (right) CCD measurement at USNO.

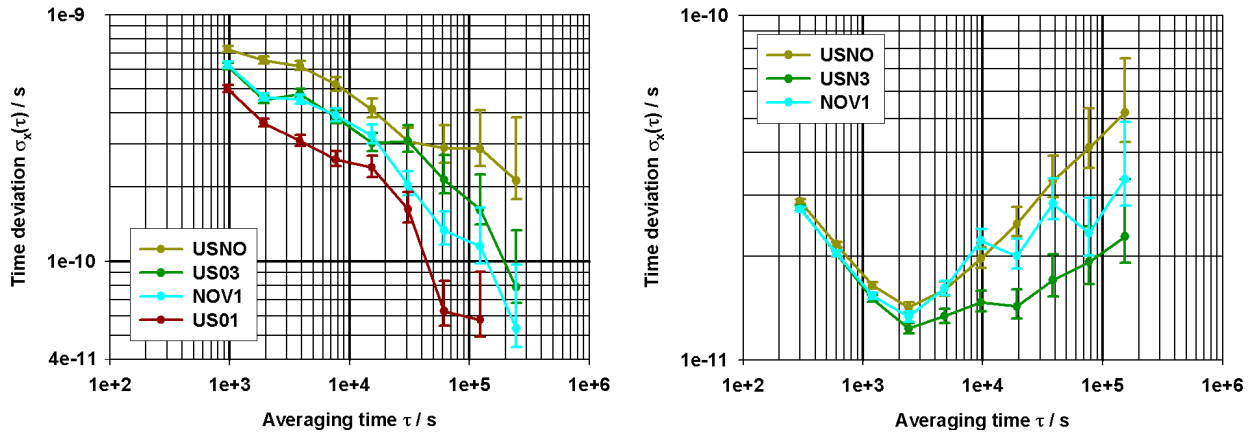

Figure 8. Log plot of the time deviations of the CCD measurements at USNO for code (left plot) and carrier phase (right plot).

For all code measurements, the TDEV indicates that the data can be averaged to about  $10^5$  s, also if we distrust the last point of the calculation. To account for the fact that at PTB each CCD measurement period was 8 days, we decided to limit the averaging period to 1 day in order to get at least eight new data points. For the PPP carrier-phase data, the averaging period has to be shorter, for example at about 2000 s for all FR at USNO, as depicted in Figure 8. In this case, we have taken the average of eight 300 s spaced data, which leads to an averaging time of 2400 s.

In Table 3, the results at PTB are listed. CCD1 and CCD2 denote the mean value of the averaged CCD measurements TR-FR before and after the travel, respectively. AVT1 and AVT2 are the averaging periods estimated from the corresponding TDEV. The value  $C_1$  is the mean value of CCD1 and CCD2. The values in brackets for PTBB and PTBG are the PPP results after adding the internal delays taken from the CGGTTS files in order to show the consistency with the P3 results. The PPP results are in good agreement with the P3 results. The underlined value is the contribution to the statistical uncertainty.

Table 3. Results of the CCD measurement at PTB. Values are rounded to the second decimal.

Type	FR	AVT1	CCD1 / ns	AVT2	CCD2 / ns	C <sub>1</sub> / ns	dCCD / ns	SD1 / ns	SD2 / ns
P3	PT02	1 day	-7.32	1 day	-7.65	-7.49	<u>0.33</u>	0.17	0.09
P3	PT03	1 day	-517.57	7680 s	-518.36	-517.96	<u>0.79</u>	0.15	0.78
C/A	PT05	No avg.	-6.33	1920 s	-6.18	-6.25	-0.15	<u>1.05</u>	0.82
P3	PT06	7680 s	6.79	3840 s	6.19	6.49	0.59	<u>0.98</u>	0.92
PPP	PTBB	1200 s	-525.65 (-7.21)	2400 s	-525.98 (-7.53)	-525.81 (-7.37)	<u>0.33</u>	0.25	0.22
PPP	PTBG	1200 s	-432.58 (-516.78)	2400 s	-434.03 (-518.23)	-433.30 (-517.50)	<u>1.45</u>	0.28	0.33

Table 4 summarizes the results at USNO. Here, the internal delay of the receivers is applied to both code and phase measurements, as for the TR of type GTR50. AVT stands for the averaging period. The value C<sub>2</sub> is directly the mean value of the averaged CCD data and the SD is the contribution to the statistical uncertainty.

Table 4. Results of the CCD measurements at USNO. Values are rounded to the second decimal.

Type	FR	AVT	C <sub>2</sub> / ns	SD / ns
P3	USNO	1 day	-631.45	0.30
C/A	US01	1 day	-8.59	0.11
P3	US03	1 day	-7.14	0.19
P3	NOV1	1 day	-6.85	0.12
PPP	USNO	2400 s	-628.55	0.11
PPP	USN3	2400 s	-7.15	0.13
PPP	NOV1	2400 s	-6.88	0.14

The values for P3 and PPP are in good agreement for US03/USN3 and NOV1. The discrepancy of about 3 ns for the receiver USNO is due to a position error of about 1.5 m with respect to the “true” position and the other receivers. If the position will be corrected in the future (to decrease the noise), the calibration value C<sub>2</sub> is no longer valid for this receiver. We note that the USNO receiver is not directly connected to UTC (USNO). It is referenced to a different clock that is kept close in frequency to UTC (USNO), but with a large phase offset.

Table 5 shows the calibration values and the corresponding uncertainty for all possible links between USNO and PTB. The uncertainties are below 2 ns, as in previous exercises [1,2].

Table 5. Calibration values and corresponding uncertainties for all possible GPS links. The values are rounded to the second decimal after calculation.

Type	Link	C <sub>GPS</sub> / ns	u <sub>a</sub> / ns	u <sub>b</sub> / ns	U / ns
C/A	US01-PT05	2.27	1.06	0.58	1.21
P3	USNO-PT02	623.97	0.45	0.58	0.73
P3	USNO-PT03	113.49	0.84	0.58	1.02
P3	USNO-PT06	637.94	1.02	0.58	1.18
P3	US03-PT02	-0.35	0.38	0.58	0.69
P3	US03-PT03	-510.82	0.81	0.58	1.00
P3	US03-PT06	13.63	0.99	0.58	1.15
P3	NOV1-PT02	-0.63	0.35	0.58	0.68
P3	NOV1-PT03	-511.11	0.80	0.58	0.99
P3	NOV1-PT06	13.34	0.99	0.58	1.15
PPP	USNO-PTBB	102.57 (621.18)	0.35	0.52	0.63
PPP	USNO-PTBG	195.25 (111.05)	1.46	0.52	1.55
PPP	USN3-PTBB	-518.83 (-0.22)	0.35	0.52	0.63
PPP	USN3-PTBG	-426.16 (-510.36)	1.46	0.52	1.55
PPP	NOV1-PTBB	-519.09 (-0.49)	0.36	0.52	0.63
PPP	NOV1-PTBG	-426.42 (-510.62)	1.46	0.52	1.55

The link which is used by the BIPM for the TAI computation if no TWSTFT data are available is the link USN3-PTBB. The small calibration value correction indicates that the internal delays of the receivers were aligned to another calibration, namely to one of the X-band calibrations mentioned before.

## TWSTFT CALIBRATION

For the validation of our results, we have applied the new calibration value to US03-PT02 P3 data taken during the last 25 days when the TWSTFT X-band link was still used for TAI computation. Due to the very long baseline between USNO and PTB, we decided to evaluate the GPS data in the AV mode. The GPS data were compared to values obtained by a linear interpolation between two adjacent X-band measurements. This double difference data are affected by significant outliers related to the X-band link as well as to the GPS link. To clean the data from all anomalies, a  $3\sigma$  filter is applied iteratively until it had no effect on the remaining data. In this process, about 5% of the data were discarded.

In a second step, we calculated the TDEV, as done for the GPS calibration, and calculated daily averages of the data (Figure 9). According to (3), the mean value of this daily averages is the calibration value for the X-band link, which validates in this special case (the X-band link is no longer operational) the GPS calibration. The uncertainty is calculated by geometrically adding the uncertainty of the GPS calibration and the SD of the single averaged double difference data around the mean. We calculated

$$C_{\text{TWSTFT,X}} = -0.71 \text{ ns} \pm 0.92 \text{ ns},$$

which demonstrates that our calibration campaign was successful and that a TWSTFT link can be calibrated with an uncertainty less than 1 ns in favorable cases.

The calibration of the operational Ku-band link was done the same way described above, but at a period after the calibration campaign. Due to the long period of 32 days, we were able to choose an averaging period of 4 days without violating our limit of at least eight data points (Figure 10).

The calibration constant for the Ku-band link was found to be

$$C_{\text{TWSTFT,Ku}} = 3.67 \text{ ns} \pm 1.26 \text{ ns.}$$

Here, the uncertainty is also well below 2 ns. Discussion of the apparent discrepancy is ongoing among USNO, BIPM, and PTB.

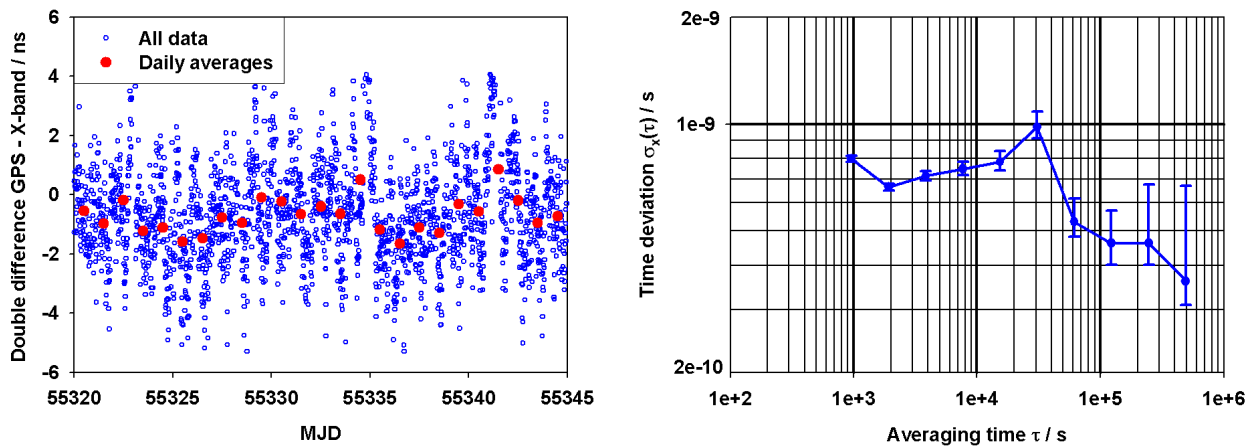

Figure 9. GPS - X-band double differences (left plot) and related TDEV (right plot).

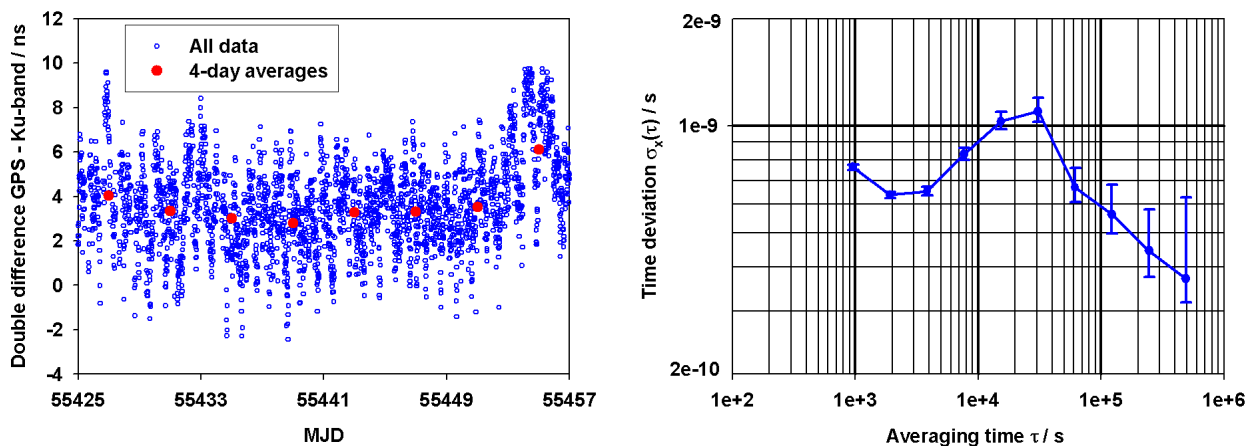

Figure 10. GPS - Ku-band double differences (left plot) and related TDEV (right plot).



## CONCLUSION AND OUTLOOK

We have reviewed the principles of a relative GPS link calibration campaign using a travelling GPS receiver, which could also serve as a cost-effective method to calibrate TWSTFT links, especially in the case of two transponders, where a calibration with one traveling TWSTFT station is not possible [15].

We have introduced PTB's new calibration setup, consisting of a state-of-the-art GTR50 time and frequency receiver, an SR620 time-interval counter, and a monitor and keyboard, everything included in a small transportable rack. Due to the usage of the same SR620 counter at both sites, the systematic uncertainty due the internal delays of this type of counter cancels out, but uncertainty contributions due to the trigger level timing error of the SR620 as well as of the GPS receiver's internal counter and nonlinearities in the SR620 remain. In order to cancel out more error contributions, we consider updating the calibration setup as depicted in Figure 9.

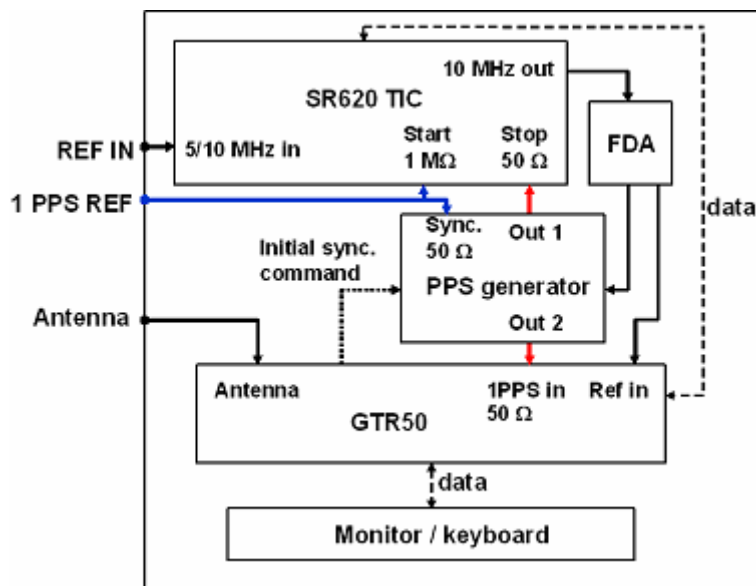

Figure 9. Proposal for a future update of the calibration setup.

If the 1 PPS signal is generated with a PPS generator from the reference frequency, the trigger level timing error of the stop channel of the SR620 as well as the error of the receiver's internal counter will completely cancel out.

The links between USNO and PTB were calibrated utilizing the new setup. The uncertainty estimation and the data handling were optimized and all links are calibrated with an uncertainty well below 2 ns.

The calibration of the operational TWSTFT Ku-band link verified that a TWSTFT can be calibrated using GPS with an uncertainty below 2 ns. The validation of the GPS calibration with calibrated X-band data showed the applicability of GPS-based relative calibration campaigns on long baselines and the potential to reach the sub-nanosecond uncertainty level under good circumstances.

## ACKNOWLEDGMENTS

We wish to thank C. Richter (PTB) and S. Krenauer (PTB) for their help in constructing the calibration setup and D. Matsakis (USNO) for helpful discussions. T. Feldmann acknowledges the support by the Centre for Quantum Engineering and Space-Time Research (QUEST), Leibniz Universität Hannover.

## DISCLAIMER

The involved institutes do not endorse any commercial products which are identified in the text for the purpose of scientific clarity only, nor do they permit any use of this document for marketing or advertisement.

## REFERENCES

- [1] H. Esteban, J. Palacio, F. J. Galindo, T. Feldmann, A. Bauch, and D. Piester, 2010, “*Improved GPS based time link calibration involving ROA and PTB,*” **IEEE Transactions on Ultrasonics, Ferroelectrics, and Frequency Control**, UFFC-57, 714-720.
- [2] T. Feldmann, A. Bauch, D. Piester, A. Stefanov, L.-G. Bernier, C. Schlunegger, and K. Liang, 2010, “*On improved GPS based link calibration of the time links between METAS and PTB,*” in Proceedings of the 24<sup>th</sup> European Frequency and Time Forum (EFTF), 13-16 April 2010, Noordwijk, The Netherlands, Paper 12.3.
- [3] D. Piester, A. Bauch, L. Breakiron, D. Matsakis, B. Blanzano, and O. Koudelka, 2008, “*Time transfer with nanosecond accuracy for the realization of International Atomic Time,*” **Metrologia**, **45**, 185-198.
- [4] H. Esteban, J. Palacio, F.J. Galindo, and J. Garate, 2009, “*GPS receiver performance test at ROA,*” in Proceedings of the 40<sup>th</sup> Precise Time and Time Interval (PTTI) Systems and Applications Meeting, 1-4 December 2008, Reston, Virginia, USA (U.S. Naval Observatory, Washington, D.C.), pp. 349-360.
- [5] T. Feldmann, D. Piester, A. Bauch, and T. Gotoh, 2008, “*GPS carrier phase time and frequency transfer with different versions of precise point positioning software,*” in Proceedings of the 40<sup>th</sup> Precise Time and Time Interval (PTTI) Systems and Applications Meeting, 1-4 December 2008, Reston, Virginia, USA (U.S. Naval Observatory, Washington, D.C.), pp. 403-414.
- [6] A. Proia, G. Cibiel, and L. Yaigre, 2010, “*Time Stability, Electrical Delay and Temperature Sensitivity of Dual Frequency GPS Receivers,*” in Proceedings of the 24<sup>th</sup> European Frequency and Time Forum (EFTF), 13-16 April 2010, Noordwijk, The Netherlands.
- [7] J. Kouba and P. Heroux, 2002, “*Precise Point Positioning Using IGS Orbit and Clock Products,*” **GPS Solutions**, **5**, no. 2, 12-28.
- [8] “*SR620 Operating Manual and Programming Reference*” (Stanford Research Systems, Sunnyvale, Cal.).
- [9] P. Panek, Dicom CZ and UFE, private communication.

- [10] I. Prochazka and P. Panek, 2009, “*Nonlinear effects in the time measurement device based on surface acoustic wave filter excitation,*” **Review of Scientific Instruments**, **80**, 076102.
- [11] W. Lewandowski and C. Thomas, 1991, “*GPS Time transfers,*” in **Proceedings of the IEEE**, **79**, 991-1000.
- [12] G. Petit, 2009, “*The TAIPPP pilot experiment,*” in Proceedings of the European Frequency and Time Forum (EFTF) and IEEE International Frequency Control Symposium Joint Conference, 20-24 April 2009, Besançon, France (IEEE), pp. 116-119.
- [13] D. Matsakis, K. Senior, and P. Cook, 2002, “*Comparison of continuously filtered GPS carrier-phase time and frequency transfer with independent daily GPS carrier-phase solutions and with two-way satellite time transfer,*” in Proceedings of the 33<sup>rd</sup> Precise Time and Time Interval (PTTI) Systems and Applications Meeting, 27-29 November 2001, Long Beach, California, USA (U.S. Naval Observatory, Washington, D.C.), pp. 63-88.
- [14] P. Defraigne and G. Petit, 2004, “*Time Transfer to TAI using geodetic receivers,*” **Metrologia**, **40**, 184-188.
- [15] D. Piester, T. Feldmann, A. Bauch, M. Fujieda, and T. Gotoh, 2009, “*Concept for an Accurate Calibration of Long Baseline Two-Way Satellite Time and frequency Transfer (TWSTFT) Links via Two Separated Transponders on One Telecommunication Satellite,*” in Proceedings of the Joint Conference of the 22<sup>nd</sup> European Frequency and Time Forum (EFTF) and IEEE International Frequency Control Symposium, 20-24 April 2009, Besançon, France (IEEE), pp. 1076-1081.