



ELSEVIER

Contents lists available at ScienceDirect

## Renewable and Sustainable Energy Reviews

journal homepage: [www.elsevier.com/locate/rser](http://www.elsevier.com/locate/rser)

## Performance study of different solar dryers: A review

A.G.M.B. Mustayen<sup>a</sup>, S. Mekhilef<sup>a,\*</sup>, R. Saidur<sup>b,\*\*</sup><sup>a</sup> Power Electronics and Renewable Energy Research Laboratory (PEARL), Department of Electrical Engineering, University of Malaya, 50603 Kuala Lumpur, Malaysia<sup>b</sup> Department of Mechanical Engineering, University of Malaya, 50603 Kuala Lumpur, Malaysia

## ARTICLE INFO

## Article history:

Received 6 August 2012

Received in revised form

23 February 2014

Accepted 9 March 2014

## Keywords:

Solar energy

Convective solar dryer

Indirect solar dryer

Direct solar dryer

## ABSTRACT

Crop drying is essential for preservation in agricultural applications. It is performed either using fossil fuels in an artificial mechanical drying process or by placing the crop under the open sun. The first method is costly and has a negative impact on the environment, while the second method is totally dependent on the weather. By contrast, using a solar dryer is comparatively cheaper and more efficient. Some solar dryers run without electrical grid power or fossil fuels. This paper presents the state of various kinds of solar dryers that are widely used today. The indirect, direct, and mixed mode dryers that have shown potential in drying agricultural products in the tropical and subtropical countries are discussed. Aside from identifying the active and passive mode solar dryers, we also highlight the environmental influence on solar energy (harnessing) that plays a vital role in the solar drying sector. This paper also presents the related technologies that can help improve existing solar dryers.

© 2014 Elsevier Ltd. All rights reserved.

## Contents

1. Introduction.....	463
2. Types of solar dryers.....	465
2.1. Open sun drying.....	465
2.2. Direct solar dryer.....	465
2.3. Indirect solar dryer.....	466
2.4. Mixed-mode solar dryer.....	466
2.5. Natural convection solar dryer (passive mode solar dryer).....	467
2.6. Forced convection solar drier (active mode solar dryer).....	468
3. Applications of different solar dryers.....	469
4. Conclusions.....	469
Acknowledgment.....	469
References.....	469

## 1. Introduction

Most developing countries are unable to solve their food problems for the entire population because of the rapidly increasing number of people in their respective territories. This rapid population increase has a direct impact on food balance. The quality and quantity of food grains are deteriorating because of

poor processing techniques and shortage in storage facilities. To maintain the right balance between food supply and population growth, reducing food losses during production time is mandatory. However, maximizing the food production capabilities of small farmers in rural areas is difficult. To solve the problem, drying has become one of the main processing techniques used to preserve food products in sunny areas.

However, traditional open sun drying has some disadvantages. For the past few years, scientists and researchers have been trying to find the best alternative to overcome this problem. They invented various kinds of solar dryers for agricultural products and have continuously worked to improve these dryers.

\* Corresponding author. Tel.: +60 379677611.

\*\* Corresponding author. Tel.: +60 379677667.

E-mail addresses: [saad@um.edu.my](mailto:saad@um.edu.my) (S. Mekhilef), [saidur@um.edu.my](mailto:saidur@um.edu.my) (R. Saidur).

The Earth has abundant solar radiation. In recent years, the use of solar energy has become more popular. Solar energy can be used in various processes such as drying, heating, cooking, and distilling. In terms of energy application, solar energy is categorized into electrical and thermal applications. In the agricultural sector, the use of solar thermal systems to conserve grains, fruits, and vegetables is feasible, economical, and ideal for farmers in many developing countries.

In the two stages of the drying process, the first phase occurs when heat is applied to the surface of the drying material at a constant rate, and the second process involves decreasing the drying rate [1]. Using a solar dryer is also advantageous for drying foods, vegetables, and grains so that they can be stored for a long time. Comparing solar drying and open sun drying, the former has many advantages compared with the latter. For example, solar drying increases the quality of products. Solar dryers in different sizes and types are used to dry various agricultural materials. Therefore, dryer selection is very important in this sector as the economic aspect should also be considered [2]. At present, researchers are finding ways to reduce the use of fuels in solar drying.

Renewable energy can play an effective role to meet energy demand. Among all, solar energy is most reliable and environmental friendly. We can use it as solar PV, solar thermal for pumping and drying crops in agricultural sectors [3,4]. Drying is an essential process in the conservation of agricultural products. In the drying sector, the supply and demand of energy is an important consideration. Solar energy storage can minimize the gap between supply and demand in this case. At steady state conditions, more efficient and cost-effective dryers play a vital role in substituting for the demand for fuel in many developing countries. Solar drying has very few barriers that can be improved and is already being applied in the agricultural sector with positive results.

Having a solar storage system is important in energy conversion and is responsible for drying many agricultural products even when direct sunlight is not available [5]. Although many agricultural food products, such as fruits, grains, and vegetables are often dried under the open sun, this method can lead to reduced quality and quantity [6]. Among all renewable energy sources, such as air, wind, and water, solar energy has the least impact on the environment. Therefore, in many tropical and subtropical areas in the world, open sun drying is still used. However, despite the fact that it is inexpensive, the final quality of the dried products is not up to international standard. Open sun drying also has other disadvantages. First, it is labor intensive [7–9]. Second, the products being dried can be spoiled because of rain, wind, moisture, and dust. Third, the quantity of the product may be reduced when birds, animals, or insects “attack” the products being dried. Fourth, this process fully depends on excellent weather conditions.

As alternatives, appropriate drying technologies can be used so that the product quality can be improved and product losses can be reduced. Solar drying is the best alternative that can help improve the quality of products [10,11]. One example is presented by Barnwal and Tiwari (2008) [12], who developed a photovoltaic (PV) greenhouse thermal dryer for seedless grapes. In their system, they calculated the evaporation of moisture, surrounding grape temperature, ambient air humidity, and greenhouse temperature to examine heat and mass transfer. They obtained satisfactory results [12].

During the drying period, maximum SR, maximum efficiency, and minimum moisture content at ambient temperature and humidity should be considered. In the previous studies, some AI techniques such as artificial neural network, genetic algorithm, web-based expert system, fuzzy logic and neuro-fuzzy inference systems etc. are used to obtain the optimal range of solar radiation

that can increase the drying rate. Experimentally, it has been proven that such techniques are used in predicting the dryer operation and obtaining excellent output.

In drying system the equilibrium theoretical model does enhance the understanding of the physics of moisture sorption. Purely empirical equations for specific conditions offer better alternatives until fairly accurate theoretical or semi-theoretical models are developed. The models have fallen short of predicting accurately the exact processes involved in drying, due to over implication of assumptions. These models for specific products and conditions offers better predictions. In this study some established moisture equilibrium models are mentioned.

The isothermal moisture equilibrium theory by Langmuir [13] is based on the classical kinetic model of balance of evaporation and condensation rates of vapor for a monolayer of water vapor on the internal surface of materials. This gives the volume of water absorbed by a product isothermally at a vapor pressure  $P_v$  as

$$V_v = V_m \left[ \frac{bP_v}{(1 + bP_v)} \right] \quad (1)$$

A model by Kelvin [14] which considers moisture absorption in a solid based on capillary condensation within the pores of the material. The Kelvin equation expresses the relationship between the vapor pressure over a liquid in a capillary and the saturated vapor pressure at the same temperature as

$$\ln \left( \frac{P_v}{P_{vs}} \right) = \frac{2\sigma V \cos \alpha}{r' R_0 T} \quad (2)$$

Harkins and Jura [15], based on the theory of an existence of a potential field above the material surfaces, considers a balance between the work required to absorb or desorb a molecule of water and the sum of work against the potential field in bringing a vapor molecule to the surface and the energy of condensation.

$$\ln(P_v/P_{vs}) = d - e/V_v^2 \quad (3)$$

Henderson's semi-theoretical model [16] which is the most versatile moisture equilibrium model yet, expresses the relationship between the equilibrium moisture content and equilibrium relative humidity at a given temperature as

$$1 - \phi = e^{-KTM_e} \quad (4)$$

In solar drying system the condition of solar activity is very important. Solar activity depends on many forms of transient behavior of sun, specially its atmosphere, which depends upon magnetism. A deep-seated dynamo mechanism produces the sunspot-scale fields, but in the quiet Sun other effects may play a role as well [17].

Solar activity depends on some phenomena such as sunspots which are magnetic storms on the surface of the sun, solar flares that are intense blooms of radiation, coronal mass ejections that bursts of solar material that shoot off the sun's surface. In 24 h solar cycle, two types of radiations are found: solar minimum cause due to weak solar activity, galactic cosmic ray and solar maximum cause when sun's global magnetic field is about to reverse polarity. In drying sector, the maximum solar gives the maximum efficiency [18].

Application of automatic control system in drying sector can be justified by the possible reduction of manpower as well as by the higher reliability compare to manual control. Basically two types of control system used in dryer such as open-loop control system and closed loop or feedback control system. Open loop control is used when the input parameters should be constant or in case when the feedback control is not good enough. It is also called feed-forward control when one of the input variables is measured and used for adjusting of another input variable. Closed loop control is automatic control system. It is used to comparing a

signal feedback from the output with an input reference. It is also characterized the transient response of the output due to some specific variation in input. The variation is input mainly depends on the uncontrolled flow and temperatures and it also caused in different type of operations [19].

Altas and Sharaf described a fuzzy logic controller for maximum solar radiation. An on-line fuzzy logic based dynamic search, detection and tracking controller is developed to ensure maximum power point operation under excursions in solar insolation, ambient temperature [20].

## 2. Types of solar dryers

### 2.1. Open sun drying

The most common drying method used in tropical and subtropical countries involves spreading the crop into thin layers on trays, covering the mats with shadow, and exposing the product to wind and sun. The classifications of sun drying procedures are created based on the stage of processing, the location of drying, or the apprehension to solar radiation (Fig. 1) [21].

The open drying process is not suitable for large amounts of products processed by large firms. Apart from the disadvantages of higher cost of labor, larger area requirement, and decreased quality of products, it also involves a labor-intensive process before the products can be ready for storage [22]. Open sun drying depends on environmental conditions, such as solar radiation, wind, and other ambient conditions [23]. It usually leads to the deterioration of the products because of many detriments, such as reduced quantity due to the wind, wastage, rainfall, and animal and anthropological impedance. Storing the crop during the night and being subjected to rain under a shelter can lead to remoistening. As the drying process is relatively slow, considerable losses occur, including insect infection, enzymatic reactions, growth of micro-organisms, and augmentation of mycotoxin, which causes an ascertainable reduction in product quality. Non-uniform drying also leads to the degeneration of the agricultural products during storage. Serious drying problems arise, particularly in humid tropics and subtropical areas, where agricultural food products have to be dried during the rainy season.

Its many disadvantages has led sun drying to be replaced with mechanical dryers, which use fossil fuel to heat drying air and electricity to force dry air through the agricultural products. However, the advantageous application of solar energy to high-temperature solar drying systems is neither technically nor circumspcctly feasible without lowering the capacity and the reliability [24].

Jain and Tiwari [25] studied the thermal behavior of open sun drying and developed a mathematical model. They found that the rate of moisture transfer is significantly high for cauliflower and potato slice, and that the prediction of crop temperature, removal of moisture rate, and static condition of air temperature are due to ambient conditions. Open sun drying is a very slow process and can lead to considerably huge losses. Products dried under the open sun drying usually fail to reach international standard quality.

### 2.2. Direct solar dryer

As previously mentioned, solar drying is a good alternative to open sun drying. In on-farm drying of small amount of fruits, crops, and vegetables, the tent and box dryers have been developed, using locally available materials, by the farmers themselves. In this kind of solar dryer, a transparent cover is used to reduce heat losses, and it simultaneously gives the product assertive protection from rain and dust. Aeration required for removing the evaporated water is provided by ascending air forces. However, in this type of process, avoiding infestations is impossible. In many countries, very few numbers of farmers are able to produce 80% of crops during production time [26]. Mühlbauer et al. [27] studied box and tent dryers and described their performance in his work. He found that their low capacity limits their use.

Fig. 2 demonstrates the drying principle of direct solar dryers. The best example of a direct-type solar dryer is a box type or cabinet dryer. A direct-type solar dryer is commonly used in areas that receive direct sunlight for longer periods during the day. Here, the drying cabinet is constructed from 1 cm-thick pressed wood and is fully insulated by glass wool on the inside, back, and bottom walls. The slanted front wall is covered by a thick glass sheet to allow sunlight to pass through. This transparent wall may be covered with an opaque and insulated sheet for an indirect mode of dryer application. The back side of the dryer has exhaust holes through which humid air is sucked out by a fan. The lowest part of the front wall is made in such a way that it can redirect hot air from the solar collector into the chamber using a centrifugal blower [28].

Zomorodian et al. discussed a new method of using a direct solar dryer, i.e., cabinet dryer, in which solar radiation is the main source of energy for drying the products. This type of dryer has three parts: the collector, the drying cabinet, and the air blower. The absorption of solar radiation, crop temperature increase, and discharging of long wave length radiation are the main working phenomena of such dryer. The temperature inside the chamber increases above the crops. Direct convective temperature losses are then reduced to ambient levels using a glass cover, which is advantageous for increasing crop and chamber temperature. However, this type of solar dryer also has some limitations. For

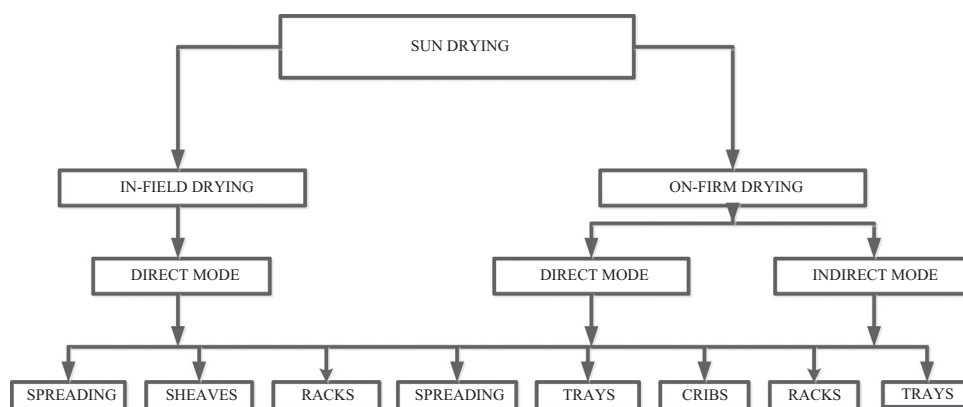

Fig. 1. Classification of sun drying methods.

example, the crops may become discolored because of direct exposure to solar cell radiation. Moisture compression inside the glass cover also decreases its transitivity [29].

A dryer for thin layer samples of rough rice was investigated by Ondier et al. [30]. It needs low temperature and low relative humidity. Experimentally established a study and tested the performance of the air flow inside a solar chimney by Maia et al. [31].

Al-Juamily et al. constructed and tested a cabinet-type solar dryer, which has a solar collector, a cabinet, and a blower. In this dryer, the temperature is the main factor that dries out the crops. The relative humidity is also small. However, its solar drying technology is affected when sunlight is not available [32].

### 2.3. Indirect solar dryer

In an indirect solar dryer, the sun's heat is first collected by the solar collectors and is then passed onto the dryer cabinet, where the drying occurs. Based on this concept, Goyal and Tiwari [33] designed a reverse observer dryer shown in Fig. 3. The solar air that enters the chamber is heated and is then made to pass through over the wet crops. The air heaters are connected. The basic concept of reverse flat plate collector is used to dry food products in a solar cabinet-type dryer. Here, a solar air heater is used to heat the air that enters the chamber [22]. The heated air then turns into warm humid air, which passes through an outlet. This kind of dryer is better than other dryers in terms of solving various equations based on energy balance. It also has better performance than other conventional cabinet type of dryers.

Sharma et al. examined the performance of an indirect-type solar dryer and found that under hostile weather situations, the dryer is still capable of giving good output. Moreover, it is ideal for small farms because of its low-cost requirements. The dryer contains a flat plate collector, a drying chamber, and thermally and acoustically insulated pipes joined between the collector and chamber. Under unfavorable weather situations, this drying unit

can still produce good quality products. It is available mostly for small farms because of its low investment [34].

Sharma et al. also reported the basic construction and overall performance of an indirect-type multi-self-dryer for fruits and vegetables in another study [35]. This study shows that high-quality dried products can be obtained by increasing apparent drying rate and drying efficiency. A mathematical model was established by simplifying Fick's equations, diffusion theory and it resulted in a very satisfactory output. In this kind of drying process, the chamber temperature and thickness of the drying samples are the main factors to be considered [36].

El-Sebaai et al. designed and tested an indirect type of natural convectional dryer that uses an absorber plate. They recorded the solar radiation, distribution of temperature in various parts of the drying system, and relative humidity. They found that drying time is eminently decreased by the storage and chemical pretreatment of drying crops [37].

### 2.4. Mixed-mode solar dryer

The isometric illustration of a mixed-mode dryer is shown in Fig. 4. The mixed-mode solar dryer has no moving parts, which is why it is called the passive dryer. This type of dryer acquires energy from the rays of the sun that enters through the collector lustering. The inside surface of the collector is painted black, and the sun's rays are harnessed by trapping the heat of the air that is collected inside the chamber. A previous study that examined the design and performance of this kind of solar dryer verified the accelerated drying process and its ability to dry agricultural products by quickly reaching better conditional moisture level, thus making it ideal for food preservation [38]. Simate discussed the basic concepts by involving computer modeling for mixed-mode solar dryers [39].

Fig. 5 shows the essential features of the mixed-mode solar dryer. This kind of dryer consists of a separate solar collector and a drying unit. A transparent cover is affixed on top of the dryer, the

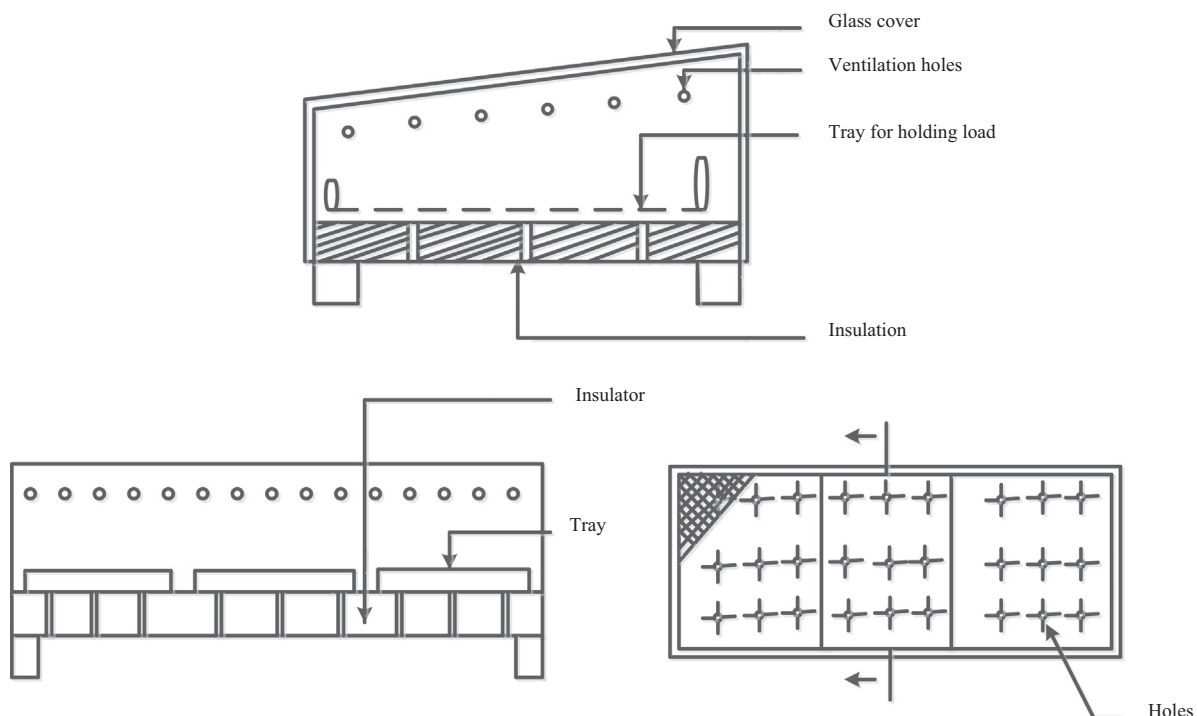

Fig. 2. Direct solar dryer.

solar collector, and the drying unit. The collector receives the solar radiation. Exell and Kornsakoo introduced a cheap and simple mixed-mode dryer for farmers [7]. This kind of dryer is often used for drying crops in the wet season.

Bala and Woods developed a solar dryer using the basic concept of simulation computing method to obtain optimal dimensions [41]. A previous technology for drying grains using solar energy, in which inlet air is heated and then passed through over grains by a fan, has been improved by Brenndorfer et al. [42].

A mixed-mode type, box type, and open floor-type solar drying systems for rough rice have been reported by Zaman and Bala. They also presented some equations on natural air flow, which has a major impact on calculating the values used in this kind of drying system. Drying temperature and moisture constant are the most important variables for controlling the drying rate. Comparing the three kinds of dryers, the mixed-mode dryer is the best of the three because it has the highest drying rate, followed by the box dryer [43].

An active mixed-mode dryer for drying rough rice has been designed, tested, and evaluated by Zomorodian et al. Their drying system features a drying chamber, an inlet and outlet bin, and a plenum chamber. This system consists of two experimental applications. Mass flow rate and discharge interval time were examined by both the first and the second applications. Moisture content was included in the second one. Based on the results, they found that the mass flow rate effect and discharge rate of crop drying are good. Moreover, this system gives satisfactory results in terms of drying efficiency and moisture content. The maximum efficiency of the system was recorded at 21.24%, and the energy consumed during the drying process was 6–8%. Final moisture content was 13% at ambient temperature (25 °C) [44].

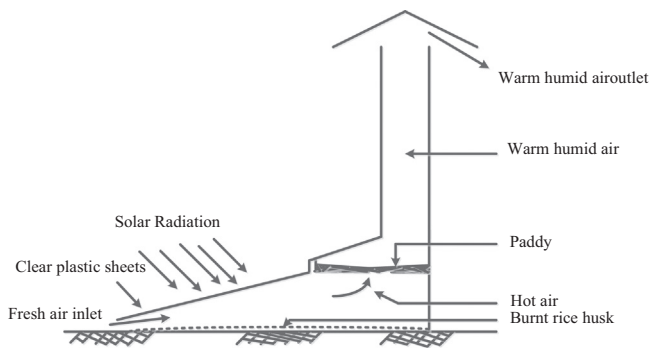

Fig. 3. Indirect solar dryer.

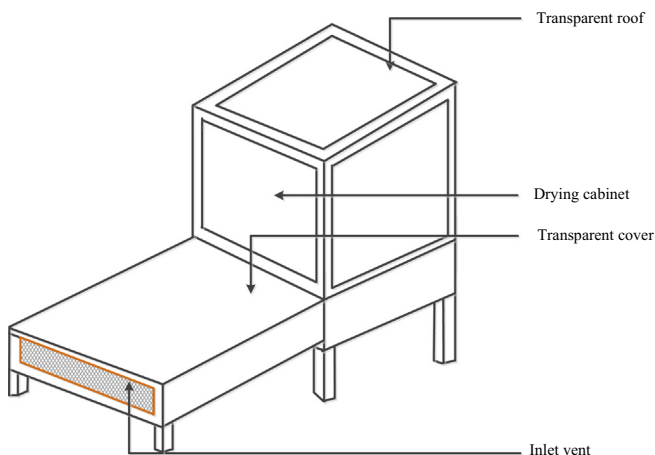

Fig. 4. Isometric illustration of the mixed-mode solar dryer.

A simple mixed-mode solar dryer has been designed and developed in another work. This system is driven by the principle of thermal test procedure and is suitable for indoor drying experiments for cylindrical potato samples. This kind of dryer can be used in upgrading the performance level in terms of gaining the minimum moisture content ratio during drying time [45].

For a solar assisted crop drying system a mathematical design was proposed by Santos et al. [46] which assessing the combination of solar collector area and energy needs that meets the requirement of load.

Bala et al. also discussed the performance study of a solar tunnel dryer for jackfruit bulbs and leather. They used artificial neural network to predict the potentiality of the dryer [47].

## 2.5. Natural convection solar dryer (passive mode solar dryer)

A natural convection solar dryer needs minimum expenditure for controlling the drying temperature. However, its drying rate is limited. This kind of solar dryer obviously plays a vital role in the drying sector because of its low cost. It has also become popular because of its simple maintenance and operation. Between a natural convection solar dryer and a forced convection dryer, the former is more suitable and is one of the oldest types of dryers available. It consists of a collector, a transparent sheet, and a unit for drying; it is covered by a shade on top. These parts are connected in a series, comprising a system that can obtain very satisfactory drying rates. This type of model was first introduced by Oosthuizen [9].

A mathematical model for simulating an indirect natural convection-type solar dryer for rough rice drying has been reported by Bala and Woods [48]. They also developed a technique and discussed the performance for optimizing the dryer. Increasing the capacity of drying using this dryer is possible using a solar air heater, as shown in Fig. 6. For agricultural drying purposes, they investigated the implementation of this system to ensure food preservation in rural areas. They also presented the performances of different kinds of solar dryers and primary HTA [49].

A direct-type natural convection solar dryer is designed and constructed using wood, blades of glass, and locally available metals. This dryer has been experimentally tested for drying agricultural goods. To predict drying effectiveness, it is important to determine some parameters such as ambient temperature, air mass flow of drying system, and incident heat fluxes. Solar incident radiation, air mass flow, and effectiveness have been

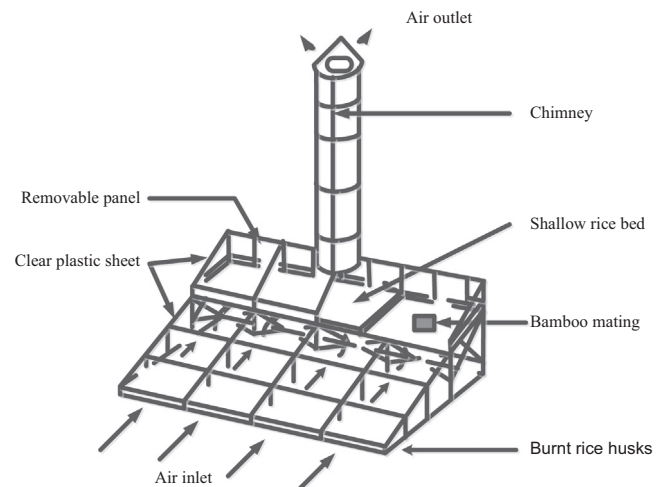

Fig. 5. A mixed-mode solar dryer [40].

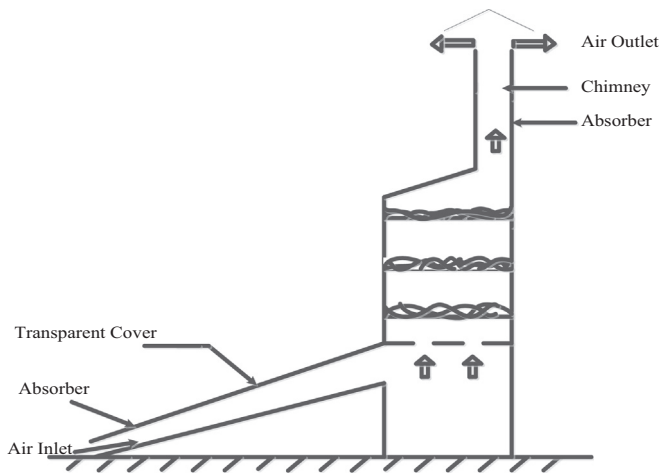

Fig. 6. Indirect natural convection dryer.

analyzed in a previous work to evaluate the thermal (heat and mass transfer) performance of the dryer [40]. Garg and Kumar presented a semi-cylindrical natural convection solar tunnel dryer and estimated its performance under force circulation mode. They found that the flow rate and inlet temperature improve in relation to the length and radius of the collector [50]. A feasible convectional dryer with solar chimney was described by Ferreira et al. [51] which is used for drying all kinds of agricultural products.

However, the natural convection solar drying system has a limited capacity. Moreover, the drying rate is delayed and highly dependent on atmospheric conditions because of a little float for inducing air flow inside the dryer, thus reducing the quality of the drying products especially in adverse weather conditions [52].

A new type of solar dryer has been designed and tested by Later Ezeike. This dryer has a very simple design and provides high efficiency in ambient atmosphere. It consists of a flat plate air collector, a drying cabin, and a dehumidification chamber. It is used in the low-isolation period because of its additional heat gain by two wall collectors in the cabinet in order to contain the desiccant, which is a type of silica gel placed in the dehumidification chamber [53].

#### 2.6. Forced convection solar drier (active mode solar dryer)

Electricity is needed to operate the fans of a forced convection solar dryer. However, many rural areas either have no electricity or have to incur high costs to generate the electricity used to run this type of dryer. Therefore, these types of dryers are not widely applicable in many developing countries. To avoid the above-mentioned disadvantages, a natural convection solar dryer may be used. This type of dryer is not dependent on electricity like a forced convection solar dryer. Its advantages include low energy cost, ideal shrinkage in the drying period, better drying capacity, minimization of mass losses, and good quality of the dried products.

For drying shelled and unshelled pistachio samples, the least square-method has been applied in the solar-assisted drying system. This kind of solar dryer is more appropriate for drying pistachios in ambient temperature. The shelf temperature, weight loss of sample, ambient moisture content, and distribution of solar radiation are accurately measured, and the pistachio samples are perfectly dried in the assisted forced convection dryer [54].

An analytic model of a cabinet-type solar dryer has been designed and evaluated based on its performance in terms of heat and mass

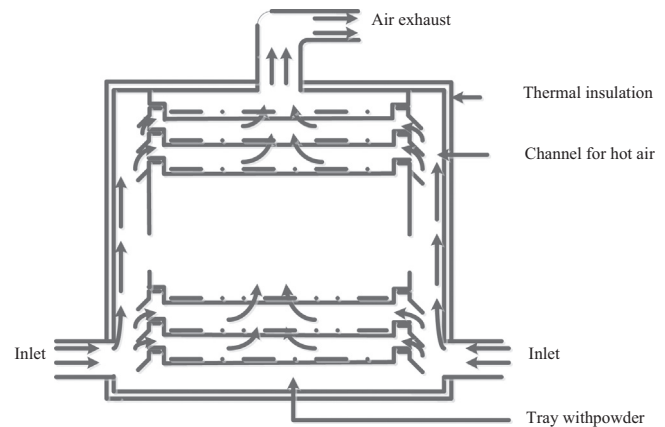

Fig. 7. Schematic diagram of a drying cabinet used for a custard powder drying system [58].

transfer phenomena, wind speed, relative humidity, product thickness, and so on. This model is suitable for predicting the temperature and moisture content under control and constant rate [55].

A batch type-solar drying system has been proposed. Its drying performance is predicted using drying rate, drying temperature, and moisture content, which are time dependent. This system allows for the shrinkage of particles. Air temperature is necessary to complete the drying process, and all its existing parameters are independent [56].

An indirect-type forced convection dryer is integrated to various realistic heat storage metals. The drying system consists of a flat plate-shaped solar air heater with a heating storage unit, a drying chamber, and a centrifugal blower. This type of dryer is used under atmospheric conditions for chili drying [57].

Arata and Sharma developed and investigated a forced convection cabinet solar dryer and found the best suitable low-cost food preservation technology. Very simple tools as well as competitively cheap and locally found materials are used to construct this type of cabinet dryer [58].

Curvelo Santana et al. [59] described an air convective dryer and simulate its kinetic characteristics and drying process for optimization using genetic algorithm. Gupta et al. described on various pre-treatments applied before drying and their influence on drying kinetics as well as product quality [60].

Fig. 7 shows a schematic diagram of the solar force convection dryer designed by Pawar et al. This type of dryer is fuel efficient and yields products with better quality than those processed through open sun drying. It also requires a shorter time period to dry the products, making it suitable for use in food and chemical industries that require huge amounts of processed products [61].

A solar-assisted drying system process that uses the most attractive and cost effective materials is commonly used in the agricultural and marine sectors. Solar-assisted drying systems are highly efficient, with an integrated life span and storage capacity. Two types of collectors, namely, air- and water-based collectors, are used in this system. In the water-based collector, a water-to-air heat exchanger is used. Mumba et al. designed and developed a dryer for grains, and it incorporates PV-powered air circulation. For controlling air temperature, PV-powered air circulation is used. A DC current is also used in the air heater section, and this fan gains power from the PV-powered air circulation [62]. A two dimensional diffusional model was established by De Lima et al. [63] to predict the simultaneous mass transfer and shrinkage during drying of solids.

Table 1 shows the different types of solar dryers which discussed in this article.

**Table 1**  
Findings of different solar dryers.

Name of solar dryer	Name of designers	Findings
Direct solar dryer	Mühlbauer [27] Ondier et al. [30] Al-Juamily et al. [32]	This is one of the simplest solar dryer of low capacity Solar radiation is the main source and overcome the discolorness of the crops Temperature is the main factor on drying rate and in off shine hours the drying technology is affected
Indirect solar dryer	Goyal and Tiwari [33] Sharma et al. [34] Sharma et al. [35] El-Sebaai et al. [37]	Reverse flat plate collector was used and gave best result High quality drying products get by producing higher efficiency It is available for small farms and under bad weather it produces good quality products The drying time is eminently decreased and drying efficiency is good
Mixed mode solar dryer	Exell and Kornsakoo [7] Simate [39] Zaman and Bala [43] Zomorodian et al. [44] Bala et al. [47]	Get optimal value of drying sectors using computer modeling Contains separate collectors and this dryer is used for drying crops in wet season The drying rate was highest and this kind of dryer is used for drying rough rice This dryer gives satisfactory result for best drying efficiency and moisture content Artificial network is used and predicting the potentiality of the dryer
Natural convection solar dryer	Oosthuizen [9] Garg and Kumar [50] Later Ezeike [53]	It is a low cost solar dryer and gives vary satisfactory result It is low cost and its performance is satisfactory Design of this dryer is very simple and gives high efficiency
Forced convection solar dryer	Midilli [54] Sodha et al. [55] Ratti and Mujumdar [56] Arata and Sharma [58] Pawar et al. [61]	Simple, available and locally found materials are used to make this type of dryer Save a large amount of fuel. Product quality is better than any others and keeps products neat and clean In ambient temperature this kind of dryer is more appropriate for drying pistachio and sample is perfectly dried in this dryer This dryer is suitable for prediction the temperature and moisture content under control and constant rate The parameters of drying system are time dependent and it is performed to predict the drying rate

### 3. Applications of different solar dryers

Direct solar drying is mainly used in on-farming sectors. It is also suitable for small farmers in rural areas, where electrical power is not available. This kind of dryer is more efficient in drying small amounts of crops, fruits, and vegetables. A locally made indirect-type natural convection dryer is useful for drying fruits and vegetables in rural areas. A solar tunnel dryer can be used for drying jackfruit bulbs and leather. The mixed-mode dryer is cheap, readily available, and can be easily made by local farmers. Tomatoes, mango slices, and grains can be dried using this dryer, which is driven by a fan. Therefore, agricultural products are dried within a short time at ambient temperature. The natural convection dryer is more advantageous and applicable than other types. Meanwhile, the low-cost indirect-type natural convection solar dryers are used for drying cassava, bananas, and rough rice, among other products. The forced convection solar dryer is used in small firms with limited financial support from large industrial sectors. This efficient dryer requires a short time to dry products and is built to last.

### 4. Conclusions

This paper presents a study on the design, performance, and application of various types of solar dryers available today. The types examined are the direct, indirect, mixed-mode, active, and passive solar dryers. This paper focuses on solar dryer models that are suitable for producing high-quality dried products. The best solutions to solve the issues associated with traditional drying (i.e., open sun drying) are discussed, along with the ways by which to create simple, inexpensive, and low-cost solar dryers. We also discuss some environmental impacts and how these can be mitigated.

### Acknowledgment

The authors would like to thank Ministry of Higher Education of Malaysia and University of Malaya for providing financial support under the research Grant no. UM.C/HIR/MOHE/ENG/16001-00-D000024.

### References

- [1] El-Sebaai A, Shalaby S. Solar drying of agricultural products: a review. *Renew Sustain Energy Rev* 2012;16:37–43.
- [2] Sharma A, Chen C, Vu Lan N. Solar-energy drying systems: a review. *Renew Sustain Energy Rev* 2009;13:1185–210.
- [3] Mekhilef S, Faramarzi S, Saidur R, Salam Z. The application of solar technologies for sustainable development of agricultural sector. *Renew Sustain Energy Rev* 2013;18:583–94.
- [4] Huda AS N, Mekhilef S, Ahsan A. Biomass energy in Bangladesh: Current status and prospects. *Renew Sustain Energy Rev* 2014;30:504–17.
- [5] Bal LM, Satya S, Naik S. Solar dryer with thermal energy storage systems for drying agricultural food products: a review. *Renew Sustain Energy Rev* 2010;14:2298–314.
- [6] Can A. Drying kinetics of pumpkinseeds. *Int J Energy Res* 2000;24:965–75.
- [7] Exell RH, Kornsakoo S. Solar rice/dryer. Bangkok (Thailand): Asian Institute of Technology; 1978.
- [8] Tiwari G, Bhatia P, Singh A, Goyal R. Analytical studies of crop drying cum water heating system. *Energy Convers Manage* 1997;38:751–9.
- [9] Oosthuizen P. The design of indirect solar rice dryers. *J Eng Int Dev* 1995;2:20–7.
- [10] Bala B, Woods J. Simulation of the indirect natural convection solar drying of rough rice. *Solar Energy* 1994;53:259–66.
- [11] Sharma VK, Colangelo A, Spagna G. Experimental investigation of different solar dryers suitable for fruit and vegetable drying. *Renew Energy* 1995;6:413–24.
- [12] Barnwal P, Tiwari G. Grape drying by using hybrid photovoltaic-thermal (PV/T) greenhouse dryer: an experimental study. *Solar Energy* 2008;82:1131–44.
- [13] Langmuir I. The adsorption of gases on plane surfaces of glass, mica and platinum. *J Am Chem Soc* 1918;40:1361–403.
- [14] Gregg SJ, Sing KS W, Salzberg H. Adsorption surface area and porosity. *J Electrochem Soc* 1967;279C.
- [15] Harkins WD, Jura G. Surfaces of solids. XIII. A vapor adsorption method for the determination of the area of a solid without the assumption of a molecular area, and the areas occupied by nitrogen and other molecules on the surface of a solid. *J Am Chem Soc* 1944;66:1366–73.
- [16] Henderson S. A basic concept of equilibrium moisture. *Agric Eng* 1952;33:29–32.
- [17] Hudson H. Solar activity. *Scholarpedia* 2008;3:3967.
- [18] Almanac. The old farmer's Almanac 2013: download iTunes eBook; 2012.
- [19] Mujumdar AS. Handbook of industrial drying. CRC Press; 2006.
- [20] Altas I, Sharaf A. A novel maximum power fuzzy logic controller for photo-voltaic solar energy systems. *Renew Energy* 2008;33:388–99.
- [21] Mühlbauer W, Esper A. Present situation. In: CIGR handbook of agricultural engineering, 1999, p. 53.
- [22] Basunia M, Abe T. Thin-layer solar drying characteristics of rough rice under natural convection. *J Food Eng* 2001;47:295–301.
- [23] Panwar N, Kaushik S, Kothari S. State of the art of solar cooking: an overview. *Renew Sustain Energy Rev* 2012;16:3776–85.
- [24] Wittwer SH. Solar energy and agriculture. *Cell Mol Life Sci* 1982;38:10–3.
- [25] Jain D, Tiwari G. Thermal aspects of open sun drying of various crops. *Energy* 2003;28:37–54.

- [26] Esper A, Mühlbauer W. Solar drying—an effective means of food preservation. *Renew Energy* 1998;15:95–100.
- [27] Mühlbauer W, Hofacker W, Müller H-M, Thaler M. Die Kaltlufttrocknung von Weizen unter energetischem und mikrobiologischem Aspekt. *Grundlagen der Landtechnik* 2013;31.
- [28] Janjai S, Bala B. Solar drying technology. *Food Eng Rev* 2012;4:16–54.
- [29] Zomorodian A, Dadashzadeh M. Indirect and mixed mode solar drying mathematical models for Sultana grape. *J Agric Sci Technol* 2009;11:391–400.
- [30] Ondier GO, Siebenmorgen TJ, Mauromoustakos A. Low-temperature, low-relative humidity drying of rough rice. *J Food Eng* 2010;100:545–50.
- [31] Maia CB, Ferreira AG, Valle RM, Cortez MF. Analysis of the airflow in a prototype of a solar chimney dryer. *Heat Transfer Eng* 2009;30:393–9.
- [32] Al-Juamily KE J, Khalifa AJ N, Yassen TA. Testing of the performance of a fruit and vegetable solar drying system in Iraq. *Desalination* 2007;209:163–70.
- [33] Goyal R, Tiwari G. Parametric study of a reverse flat plate absorber cabinet dryer: a new concept. *Solar Energy* 1997;60:41–8.
- [34] Sharma V, Colangelo A, Spagna G. Experimental performance of an indirect type solar fruit and vegetable dryer. *Energy Convers Manage* 1993;34:293–308.
- [35] Sharma V, Colangelo A, Spagna G. Investigation of an indirect type multi-shelf solar fruit and vegetable dryer. *Renew Energy* 1992;2:577–86.
- [36] Diamante L, Munro P. Mathematical modelling of the thin layer solar drying of sweet potato slices. *Solar Energy* 1993;51:271–6.
- [37] El-Sebaï A, Aboul-Enein S, Ramadan M, El-Gohary H. Experimental investigation of an indirect type natural convection solar dryer. *Energy Convers Manage* 2002;43:2251–66.
- [38] Bolaji BO, Olalusi AP. Performance evaluation of a mixed-mode solar dryer. *AU J Technol* 2008;11:225–31.
- [39] Simate I. Optimization of mixed-mode and indirect-mode natural convection solar dryers. *Renew Energy* 2003;28:435–53.
- [40] Gbaha P, Yobouet Andoh H, Kouassi Saraka J, Kaménan Koua B, Toure S. Experimental investigation of a solar dryer with natural convective heat flow. *Renew Energy* 2007;32:1817–29.
- [41] Bala B, Woods J. Simulation of deep bed malt drying. *J Agric Eng Res* 1984;30:235–44.
- [42] Brenndorfer B, Kennedy L, Mrema G. Solar dryers: their role in post-harvest processing. Commonwealth Secretariat; .
- [43] Zaman M, Bala B. Thin layer solar drying of rough rice. *Solar Energy* 1989;42:167–71.
- [44] Zomorodian A, Zare D, Ghasemkhani H. Optimization and evaluation of a semi-continuous solar dryer for cereals (Rice, etc.). *Desalination* 2007;209:129–35.
- [45] Singh S, Kumar S. New approach for thermal testing of solar dryer: development of generalized drying characteristic curve. *Solar Energy* 2012;86:1981–91.
- [46] Santos B, Queiroz M, Borges T. A solar collector design procedure for crop drying. *Braz J Chem Eng* 2005;22:277–84.
- [47] Bala B, Ashraf M, Uddin M, Janjai S. Experimental and neural network prediction of the performance of a solar tunnel drier for drying jackfruit bulbs and leather. *J Food Process Eng* 2005;28:552–66.
- [48] Bala B, Woods J. Optimization of natural-convection, solar drying systems. *Energy* 1995;20:285–94.
- [49] Sharma V, Sharma S, Ray R, Garg H. Design and performance studies of a solar dryer suitable for rural applications. *Energy Convers Manage* 1986;26:111–9.
- [50] Garg H, Kumar R. Studies on semi-cylindrical solar tunnel dryers: thermal performance of collector. *Appl Thermal Eng* 2000;20:115–31.
- [51] Ferreira AG, Maia CB, Cortez MF, Valle RM. Technical feasibility assessment of a solar chimney for food drying. *Solar Energy* 2008;82:198–205.
- [52] Tiris C, Tiris M, Dincer I. Experiments on a new small-scale solar dryer. *Appl Thermal Eng* 1996;16:183–7.
- [53] Ezeike G. Development and performance of a triple-pass solar collector and dryer system. *Energy Agric* 1986;5:1–20.
- [54] Midilli A. Determination of pistachio drying behaviour and conditions in a solar drying system. *Int J Energy Res* 2001;25:715–25.
- [55] Sodha M, Dang A, Bansal P, Sharman S. An analytical and experimental study of open sun drying and a cabinet tyre drier. *Energy Convers Manage* 1985;25:263–71.
- [56] Ratti C, Mujumdar A. Solar drying of foods: modeling and numerical simulation. *Solar Energy* 1997;60:151–7.
- [57] Mohanraj M, Chandrasekar P. Performance of a forced convection solar drier integrated with gravel as heat storage material for chili drying. *J Eng Sci Technol* 2009;4:305–14.
- [58] Arata A, Sharma VK. Performance evaluation of solar assisted dryers for low temperature drying applications—I. Plants description. *Renew Energy* 1991;1:729–35.
- [59] Curvelo Santana J, Araújo S, Librantz A, Tambourgi E. Optimization of corn malt drying by use of a genetic algorithm. *Drying Technol* 2010;28:1236–44.
- [60] Gupta P, Ahmed J, Shivhare U, Raghavan G. Drying characteristics of red chilli. *Drying Technol* 2002;20:1975–87.
- [61] Pawar R, Takwale M, Bhide V. Solar drying of custard powder. *Energy Convers Manage* 1995;36:1085–96.
- [62] Fudholi A, Sopian K, Ruslan M, Alghoul M, Sulaiman M. Review of solar dryers for agricultural and marine products. *Renew Sustain Energy Rev* 2010;14:1–30.
- [63] De Lima A, Queiroz M, Nebra S. Simultaneous moisture transport and shrinkage during drying of solids with ellipsoidal configuration. *Chem Eng J* 2002;86:85–93.