

ULTRASONIC ATTENUATION MEASUREMENTS OF *IN VIVO* HUMAN MUSCLE

J. Ophir¹, N. F. Maklad¹, and R. H. Bigelow²

Departments of ¹Radiology and ²Neurology
The University of Texas Medical School
Houston, TX 77030

Attenuation measurements were performed on the quadriceps femoris muscle of 10 normal volunteers. The measurements were made using a statistical narrowband pulse echo method operating at 4.3 MHz. The results show a normal range of 4.71 ± 0.44 dB cm⁻¹ (mean \pm S.D.). A one-way analysis of variance was performed on the data which concluded that the populations of attenuation coefficients among the subjects were indeed distinct at the $p < 0.0005$ level.

Key words: Attenuation coefficient; muscle.

I. INTRODUCTION

Attenuation measurements of the *in vivo* human muscle have not received a great deal of attention in the literature. A comprehensive review of the literature [1] shows only one study [2] performed using a pulse transmission method. The difficulties with this method are numerous, including possible errors in the measurement due to the reflectivity of the skin, attenuation in the subcutaneous layers, and nonuniform transducer axial sensitivity profiles.

A modest number of studies have in the past been carried out on human and other mammalian muscle tissues [1]. However, two issues which are largely unresolved apply to these data: the "freshness" of the tissues [3] and the similarity of the general mammalian data to human data. In the absence of comprehensive data which resolve these two issues, the applicability of these studies to *in vivo* human measurements remains in question.

The problem of measuring attenuation coefficients *in vivo* has been addressed in the past by several investigators [4-7]. Their common approach to the problem has been a statistical one, i.e. many measurements must be made on the same target in order to obtain a statistically meaningful result.

At present there are only a few methods for evaluating muscular injury and muscle disease. These methods include electromyography, muscle power testing, biochemical analysis, and soft tissue radiography. In many instances the diagnosis can only be made by muscle biopsy. Ultrasonic evaluation of muscular injuries and diseased muscles could be a potential noninvasive method for diagnosis. In muscular injuries there is usually infiltration of muscle by blood, whereas in many muscle diseases, muscular atrophy is associated with replacement of muscle by fat. Both blood and fat typically exhibit lower ultrasonic absorption than soft tissues and muscle [3]. The present study was performed to establish values of ultrasonic attenuation in normal muscles as a preliminary step towards ultrasonic evaluation of injured and diseased muscle.

ULTRASONIC ATTENUATION OF HUMAN MUSCLE

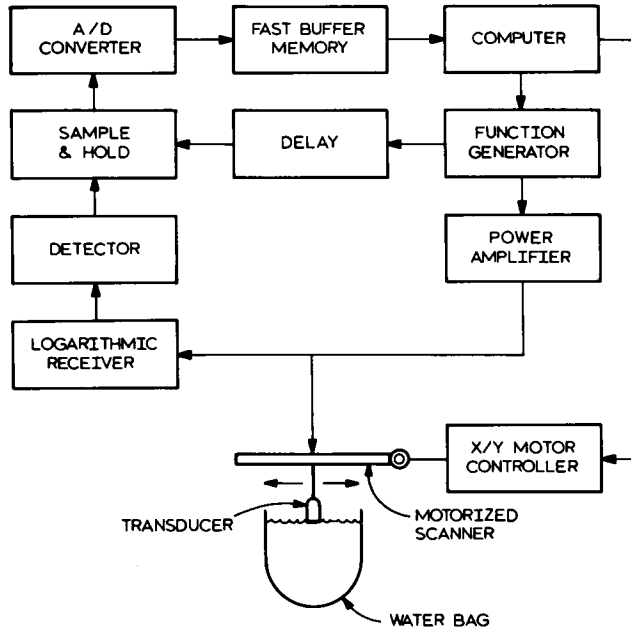

Figure 1. Block diagram of the apparatus used in the measurement of attenuation *in vivo*.

In this study, 10 subjects underwent a pulse echo statistical attenuation measurement of their quadriceps femoris muscle at 4.3 MHz, using the system described in [5]. Each individual was scanned a number of times. A one-way analysis of variance was performed on resulting data. The analysis suggests that there exists no normal value for muscle attenuation, but rather a normal range of values. The resultant range was 4.71 ± 0.44 dB cm^{-1} (mean \pm S.D.).

II. MATERIALS AND METHODS

The measurement of *in vivo* attenuation was performed using a narrow-band statistical C-scan technique [5]. The apparatus is shown in figure 1. The water filled bag rests on the subject's leg. The transducer is scanned in the water under computer control in a rectilinear fashion. The excitation pulse is a long sinusoidal burst generated by the function generator and amplified by the power amplifier. Echoes are received by a precision wideband logarithmic amplifier. A sample of the received signal is held by the sample/hold module at the prescribed delay interval after the initiation of the transmit pulse. The samples are digitized by an 8 bit A/D converter and stored in the buffer memory.

An ensemble of narrowband echoes from a constant range located at the focal spot of the transducer is collected. This is done by moving a transducer contained in a water bag mechanism in a rectilinear fashion over a typically 30 x 50 mm size plane. Echo amplitudes are recorded in spatial intervals which assure that the samples are statistically uncorrelated. The echo amplitudes were acquired using a sample-and-hold circuit operating on the demodulated RF echo signal. Statistical decorrelation was assured by choosing spatial sampling intervals which were greater than or equal to half the half-amplitude spot size of the transducer [8]. The

number of samples taken from the planar region was thus determined for given sample plane dimensions. Typically about 500 samples were taken from the plane. After sufficient samples have been collected from one plane in the tissue, the transducer is moved axially in the water, typically 5 - 20 mm, and the scan is repeated in the second plane which is separated from the first plane by the axial displacement of the transducer. Sample means are computed for data from each plane, and the difference in the population means is computed as

$$\mu_1 - \mu_2 = \bar{X}_1 - \bar{X}_2 \pm k \left(\frac{S_1^2}{n_1} + \frac{S_2^2}{n_2} \right)^{1/2}, \quad (1)$$

where

μ_1, μ_2 = the population means in the respective planes

\bar{X}_1, \bar{X}_2 = the sample means in the respective planes

S_1^2, S_2^2 = the sample variances in the respective planes

n_1, n_2 = the number of samples in the respective planes. Normally
 $n_1 = n_2 = n$.

k = student's t critical point for 95 percent confidence with
 $2n - 2$ degrees of freedom.

The difference in the population means is thus computed as the difference in the sample means plus or minus an error term which is normally computed with k corresponding to the 95 percent confidence interval.

The attenuation coefficient $\alpha_{i,j}$ of the tissue at the operating frequency is computed as

$$\alpha_{i,j}(\text{dB}) = 20 \log \left[\frac{\mu_{1i,j} - \mu_{2i,j}}{2d} \right], \quad (2)$$

where

i = the individual subject

j = the individual scan

d = the separation between the planes.

The mean attenuation coefficient for each individual $\bar{\alpha}_i$, was then computed as

$$\bar{\alpha}_i = \frac{1}{N_i} \sum_{j=1}^{N_i} \alpha_{ij}, \quad (3)$$

where N_i is the number of scans performed on the i th individual.

Ten normal male and female volunteers, age 26 to 36 were scanned during the course of 16 days. Each subject was scanned repetitively, accumulating from 4 to 22 scans per individual. In all cases, the quadriceps femoris muscle was scanned at 4.3 ± 0.1 MHz (center frequency ± 3 dB band-

ULTRASONIC ATTENUATION OF HUMAN MUSCLE

Table A. Means, standard deviations, and number of scans of attenuation coefficient in 10 volunteers. Note that the standard deviations are typically less than ± 10 percent of the means. Typical scan volumes were 15-30 cm³. Typical number of samples per plane was 500.

Individual (i)	Mean ($\bar{\alpha}_i$) dB cm ⁻¹	Standard Deviation* dB cm ⁻¹	Number of Scans (N _i)
1	4.42	0.161	20
2	4.66	0.317	22
3	5.48	0.308	10
4	4.19	0.319	15
5	5.27	0.287	15
6	4.30	0.116	6
7	5.17	0.276	19
8	4.47	0.144	12
9	4.51	0.377	10
10	4.67	0.116	4

Bartlett's test for homogeneity of variance [9], $\chi^2_9 = 24.4$, $p < 0.005$
 Kruskal-Wallis one-way analysis of variance [10], $\chi^2_9 = 93.7$, $p < 0.0005$

* For the ith individual $\bar{\alpha}_i$ is computed as in Eq. (3), and the standard deviation is

$$\left[\frac{\sum_{j=1}^{N_i} (\alpha_{ij} - \bar{\alpha}_i)^2}{(N_i - 1)} \right]^{1/2}$$

width), with special care taken to avoid the septa between muscle bundles. The ultrasonic appearance of the scanned muscle was homogeneously uniform.

III. RESULTS AND DISCUSSION

For each of the ten individuals, a number of independent measurements of the attenuation coefficient $\alpha_{i,j}$ were obtained and $\bar{\alpha}_i$ computed. (See table A). Among these ten individuals we observe significantly different values of attenuation coefficients ($\chi^2_9 = 93.7$, $p < 0.0005$). The plots of $\alpha_{i,j}$ versus time for $j=1, \dots, N_i$ showed no trend in seven individuals, a significant downward trend in two individuals, and a significant upward trend in one individual. Additionally it appears that the precision of the measurement of the attenuation coefficient varies among individuals (testing for homogeneity of within-individual variances gives $\chi^2_9 = 24.4$, $p < 0.005$). Since earlier phantom studies showed a virtually constant attenuation coefficient and precision of its measurement, we conclude that these quantities do indeed vary among individuals. This might be due to individual variations in muscle structure and composition, or the ability of an individual to maintain the same muscle tension throughout the examination. Stated differently, there are in fact distinctly different attenuation coefficients which characterize the subjects, and apparently no universal, "normal" attenuation coefficient exists. A somewhat similar conclusion has been reached by Bamber and Hill [1] in their work on liver attenuation. Rather than a normal value we must think in terms of a normal range of at-

tenuation coefficient values. In this case, we may consider the mean of this range, $\bar{\alpha}$, to be the mean of all the individual means, $\bar{\alpha}_i$ i.e.

$$\bar{\alpha}_i = \frac{1}{10} \sum_{i=1}^{10} \bar{\alpha}_i = 4.71 \text{ dB cm}^{-1} \quad (4)$$

and the standard deviation S of the range to be the standard deviation of the individual means

$$S = \left[\frac{1}{9} \sum_{i=1}^{10} (\bar{\alpha}_i - \bar{\alpha})^2 \right]^{1/2} = 0.44 \text{ dB cm}^{-1}. \quad (5)$$

It is interesting to compare these results with Hueter's data [2] obtained at 4.5 MHz. These data show that for *in vivo* biceps brachii (including skin), the average attenuation in six individuals was $5.133 \pm 0.087 \text{ dB cm}^{-1}$, and that the power law exponent of frequency dependence of attenuation ($\log \alpha / \log f$) was equal to 1.5. Taking these factors into account and nonlinearly interpolating his results for $f = 4.3 \text{ MHz}$, we obtain a mean attenuation coefficient of 4.795 dB/cm , which is within the range of our measurement. On the other hand, Hueter's *in vivo* gastrocnemius measurements (including skin) at 4.5 MHz show $\alpha = 4.5 \text{ dB cm}^{-1}$ and $\log \alpha / \log f = 1.9$. Interpolation results in a mean attenuation value of 4.15 dB cm^{-1} at 4.3 MHz.

IV. CONCLUSION

We have established that (1) the attenuation coefficients in *in vivo* muscle is significantly different among individuals; (2) the range of attenuation coefficients in normal muscle at 4.3 MHz is $4.71 \pm 0.44 \text{ dB/cm}$; and (3) in no event was the standard deviation within a given muscle larger than ± 10 percent of the mean attenuation coefficient. If in the future it is shown that the attenuation coefficient in diseased muscle does vary significantly from the normal range, this technique might have potential for screening and diagnosis.

ACKNOWLEDGEMENTS

The authors wish to acknowledge the help provided by R. E. McWhirt and P. M. Jaeger in conducting the experiments, and by Dr. Stephen A. Goss from the Indianapolis Center for Advanced Research, Inc. in providing us with reference [2].

REFERENCES

- [1] Goss, S. A., Johnston, R. L. and Dunn, F., Comprehensive compilation of empirical ultrasonic properties of mammalian tissues, *J. Acoust. Soc. Am.* 64, 423-457 (1978).
- [2] Hueter, T. F., Viscoelastic Losses in Tissues in the Ultrasonic Range, Wright Air. Dev. Cent. Tech. Rep. WADC - TR, pp. 57-706 (Contract AF 33 (616) - 2976 August, 1958).
- [3] Wells, P. N. T., *Biomedical Ultrasonics* (Academic Press, London, 1977).

ULTRASONIC ATTENUATION OF HUMAN MUSCLE

- [4] Kuc, R., Statistical Estimation of the Acoustic Attenuation Slope for Liver Tissue, Ph.D. Dissertation, Columbia University (1977).
- [5] Ophir, J. and Maklad, N. F., A New Stochastic C-scan Technique of Attenuation Coefficient Measurement in Tissue Equivalent Material, in *Proc. 23rd Ann. Mtg. AIUM*, p. 118, (Amer. Institute for Ultrasound in Medicine, Bethesda, MD, 1978), abstract only.
- [6] Jones, J. P. and Behrens, M., *In vivo* measurement of frequency dependent attenuation in normal liver, pancreas and spleen, *Ultrasonic Imaging* 3, 205 (1981), abstract only.
- [7] Lizzy, F. and Laviola, M. A., Power Spectra Measurements of Ultrasonic Backscatter from Ocular Tissues, in *1975 IEEE Ultrasonics Symp. Proc.*, 29-32 (IEEE Cat. No. 75 CHO 994-4SU).
- [8] Burckhardt, C. B., Speckle in ultrasound b-mode scans, *IEEE Trans. Sonics Ultrasonics SU-25*, 1-6 (1978).
- [9] Snedecor, G. W. and Cochran, W. G., *Statistical Methods*, pp. 296-298 (Iowa State University Press, Ames, IA, 1967).
- [10] Siegel, A., *Nonparametric Statistics for the Behavioral Sciences*, pp. 184-194 (McGraw-Hill, New York, 1956).