

# Path Tracking of dynamics of a Chaotic Memristor Circuit

H. Vazquez-Leal<sup>1\*</sup>, Y. Khan<sup>2</sup>, U. Filobello-Nino<sup>1</sup>, V. M. Jimenez-Fernandez<sup>1</sup>, A. Diaz-Sanchez<sup>3</sup>  
A. Herrera-May<sup>4</sup>, R. Castaneda-Sheissa<sup>1</sup>, L. F. Cisneros-Sinencio<sup>1</sup>, J. Sanchez-Orea<sup>1</sup>

(1) *Electronic Instrumentation and Atmospheric Sciences School, University of Veracruz, Cto. Gonzalo Aguirre Beltrán S/N, Xalapa, Veracruz, México 91000*

(2) *Department of Mathematics, Zhejiang University, Hangzhou 310027, China*

(3) *National Institute for Astrophysics, Optics and Electronics, Luis Enrique Erro No. 1, Sta. María Tonantzintla. Puebla, México, 72840*

(4) *Micro and Nanotechnology Research Center, University of Veracruz, Calzada Ruiz Cortines 455, Boca del Rio 94292, Veracruz, México.*

Copyright 2014 © H. Vazquez-Leal, Y. Khan, U. Filobello-Nino, V. M. Jimenez-Fernandez, A. Diaz-Sanchez, A. Herrera-May, R. Castaneda-Sheissa, L. F. Cisneros-Sinencio and J. Sanchez-Orea. This is an open access article distributed under the Creative Commons Attribution License, which permits unrestricted use, distribution, and reproduction in any medium, provided the original work is properly cited.

## Abstract

Since its recent invention, the Memristor has proven to be a revolutionary device due to the versatility of its applications. Among these, the study of chaotic circuits using Memristors is a fertile area to be explored. However, despite several ways to track the chaotic paths for memristive circuits have been previously proposed, all of these provide merely numeric or qualitatively solutions. As it could be necessary for some applications to have all the possible information about their dynamics, a new methodology to path tracking the chaotic trajectories for memristive circuits using the Multistage Homotopy Perturbation Method is proposed. This methodology provides a straightforward semi-analytic expression to obtain the chaotic path in an iterative way, providing both, the numeric and qualitative behaviour of the circuit.

**Keywords:** Homotopy perturbation method, Chaotic circuits, Memristor

## 1 Introduction

Industrial efforts to push electronics beyond the technological limits has resulted in a vertiginous evolution of electronic devices. As a result of this tendency, new devices like single electron transistors [3, 1, 2] have been developed. Within these, the memristor highlights for being a promising alternative to substitute the MOS transistors in modern circuits [24, 8, 9, 10, 11, 18, 26, 19, 32, 23, 27, 28, 12, 14, 7, 16, 17, 13, 25, 4, 20, 31, 6, 21, 29, 15, 30, 22, 5]; high scale of integration, memory functions and some other attractive characteristics make the memristor to be considered the most revolutionary device since the invention of the transistor [33].

As expected, many research has been carried to find applications to this innovative two-terminal device. At present, the memristor has been proposed to be used in circuits such as:

\*Corresponding author. Email address: hvazquez@uv.mx

1. Artificial neural networks [37, 34, 39, 40, 38, 36, 35].
2. Memories [42, 43, 41].
3. Image encryption [44].
4. Oscillators [45, 47, 46].
5. Chaotic circuits [49, 48, 50, 52, 51].
6. Filters [53].

Due to their nature, one of the most straightforward applications for memristors is in the construction of chaotic circuits, fundamental part of several high-end applications such as random number generators and cryptography for secure communications [54].

Along with the research on the application of memristive circuits, new mathematical and numerical tools to simulate them in the static and dynamic domains have to be proposed. Researchers in the chaos area commonly use numerical methods to path tracking the chaotic trajectories. However, numerical methods strictly provide the quantitative behaviour of the circuit, while in some cases, it is also necessary to know their qualitative behaviour. Nevertheless some other methods provides a purely qualitative solution, a method capable to provide all the information, qualitative and quantitative, of the chaotic trajectories of memristive circuits, based on the Multistage Homotopy Perturbation Method (MuHPM) [55], is proposed. This methodology is capable to deliver a valid semi-analytic expression in the vicinity of specific time instants to iteratively track the chaotic trajectories. A comparison of this method against Runge-Kutta is realized to determine their accuracy.

This article has been organized as follows.

Section 2 provides an introduction to the Multistage HPM Method;

while Section 3 shows how to track the path of a chaotic memristor circuit using the proposed method.

In Section 4, numerical simulations are provided and results will be thoroughly discussed.

Finally, a brief conclusion is given in Section 5.

## 2 Introduction to Multistage HPM Method

Homotopy Perturbation Methods (HPM) [58, 59, 66, 65, 62, 67, 63, 64, 57, 56, 60, 61, 68, 69, 70, 71] are mathematical tools to find an approximate or exact solution of a related problem. Such methods are based on both, perturbation [72, 73] and homotopy methods [85, 74, 75, 76, 77, 78, 79, 80, 81, 82, 83, 84, 86, 87, 88, 89, 90] to provide a set of non-linear differential equations in a systematic and straightforward way. Thereby, the characteristics of Multistage HPM makes this numerical method ideal to track the trajectories of a chaotic circuit. Thus, in this section the basics of Multistage HPM will be explored.

### 2.1 The Homotopy Perturbation Method

The basic idea of HPM is to introduce an homotopy parameter  $p$  which takes values ranging from 0 up to 1. When parameter  $p = 0$ , the equation usually reduces to a simple, or trivial, equation to solve. Then,  $p$  is gradually increased to 1, producing a sequence of deformations where every solution is closer to the last one. Eventually, at  $p = 1$ , the system takes the original form of the equation and the final stage of deformation provides the desired solution. Therefore, only few iterations are needed to achieve good accuracy.

The HPM method considers that a nonlinear differential equation can be expressed as

$$A(u) - f(r) = 0, \quad r \in \Omega, \quad (2.1)$$

having the boundary condition

$$B\left(u, \frac{\partial u}{\partial \eta}\right) = 0, \quad r \in \Gamma, \quad (2.2)$$

where  $A$  is a general differential operator,  $f(r)$  is a known analytic function,  $B$  is a boundary operator, and  $\Gamma$  is the boundary of the  $\Omega$  domain. The  $A$  operator, generally, can be divided into two operators,  $L$  and  $N$ , where  $L$  is the linear operator and  $N$  is the nonlinear operator. Hence, (2.1) can be rewritten as

$$L(u) + N(u) - f(r) = 0. \tag{2.3}$$

Now, the homotopy function is

$$H(v, p) = (1 - p)[L(v) - L(u_0)] + p(L(v) + N(v) - f(r)) = 0, \quad p \in [0, 1] \tag{2.4}$$

where  $u_0$  is the initial approximation solution for (2.3) which satisfies the boundary conditions and  $p$  is known as the perturbation homotopy parameter. Analysing (2.4) can be concluded that

$$H(v, 0) = L(v) - L(u_0) = 0, \tag{2.5}$$

$$H(v, 1) = L(v) + N(v) - f(r) = 0. \tag{2.6}$$

We assume that the solution for (2.4) can be written as a power series of  $p$

$$v = p^0 v_0 + p^1 v_1 + p^2 v_2 + \dots \tag{2.7}$$

Adjusting  $p = 1$  results that the approximate solution for (2.1) is

$$u = \lim_{p \rightarrow 1} v = v_0 + v_1 + v_2 + \dots \tag{2.8}$$

The series (2.8) is convergent on most cases [58, 59, 91, 92].

## 2.2 Basic Procedure of Multistage HPM method

The basic MuHPM [55] process consists of

1. Setup.  $M = (t_f - t_0)/\Delta t$ .  $M$  is defined as the number of path tracking steps or the number of HPM segments,  $t_0$  is considered as the initial time,  $t_f$  the final time, and  $\Delta t$  is the step size of time for path tracking.
2. Apply HPM method to obtain an approximate solution  $y(t)$  to the nonlinear differential equation.
3. Set  $k = 0$ .
4.  $t^* = t_0 + k\Delta t$  and initial condition  $y(t^*) = y_k$  are updated in HPM solution.
5. A prediction is performed for  $t_{k+1} = t_0 + (k + 1)\Delta t$ . That is,  $y_{k+1} = y(t_{k+1})$ .
6. Update  $k = k + 1$ .
7. Repeat steps 4, 5, and 6 until  $t^* > t_f$  or  $k > M$ .

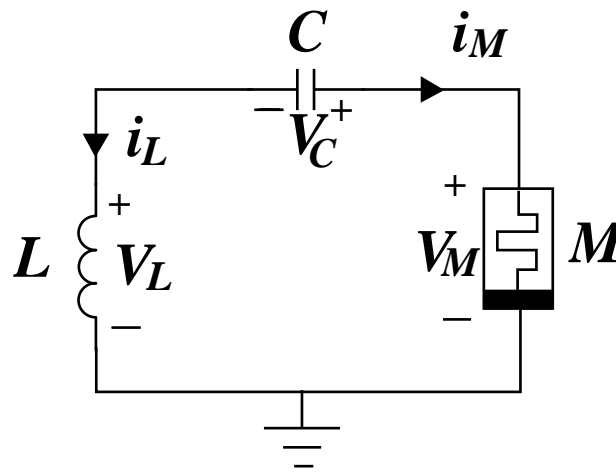

Figure 1: Chaotic circuit containing one Memristor.

### 3 Tracking the Path of Chaotic Memristor Circuits

In order to show the effectiveness of the proposed HPM method, the chaotic circuit in [51] is used as an example of the application of the proposed method to trace the chaotic paths of a memristive circuit. The circuit is composed only by three elements: two energy storage elements (an inductor and a capacitor) and a non-linear active Memristor, as shown in Figure 1. In accordance with [51], the Memristor behaviour can be modelled by

$$\begin{aligned} V_M &= \beta(z^2 - 1)i_M, \\ \frac{dz}{dt} &= i_M - \alpha - i_M z, \end{aligned} \quad (3.9)$$

where  $V_M$  is the potential drop at the Memristor,  $i_M$  represents the current flowing through the Memristor,  $\alpha$  and  $\beta$  are parameters of the device, and  $z(t)$  is the internal state of the memristive system.

The differential equation system representing the dynamic behaviour of the chaotic circuit is derived follows: the first equation is obtained from the capacitor current formulation described by

$$i_C = C \frac{dV_C}{dt}, \quad (3.10)$$

The second equation is obtained applying Kirchoff's voltage law around the closed LCM loop as

$$\begin{aligned} -V_L - V_C + V_M &= 0, \\ -L \frac{di_L}{dt} - V_C + \beta(z^2 - 1)i_M &= 0, \end{aligned} \quad (3.11)$$

Finally, a third equation is established for the variable  $z$  given by (3.9); in order to set the system

$$\begin{aligned} \frac{dx}{dt} &= \frac{y}{C}, & x(0) &= r_1, \\ \frac{dy}{dt} &= -\frac{1}{L} [x + \beta(z^2 - 1)y], & y(0) &= r_2, \\ \frac{dz}{dt} &= -y - \alpha z + yz, & z(0) &= r_3, \end{aligned} \quad (3.12)$$

where, for a simpler notation,  $x = V_C(t)$  is voltage across capacitor  $C$ ,  $y = i_M(t) = -i_L(t)$  is current through the loop,  $\alpha = 0.6$ ,  $\beta = 3/2$ ,  $L = 3$ , and  $C = 1$ .

The homotopy equation (HPM) is formulated as

$$\begin{aligned}
 (1-p) \left( \frac{dv_1}{dt} - \frac{dx_0}{dt} \right) + p \left( \frac{dv_1}{dt} - v_2 \right) &= 0, \\
 (1-p) \left( \frac{dv_2}{dt} - \frac{dy_0}{dt} \right) + p \left( \frac{dv_2}{dt} + \frac{1}{3} \left[ v_1 + \frac{3}{2} (v_3^2 - 1) v_2 \right] \right) &= 0, \\
 (1-p) \left( \frac{dv_3}{dt} - \frac{dz_0}{dt} \right) + p \left( \frac{dv_3}{dt} + v_2 + 0.6v_3 - v_2v_3 \right) &= 0,
 \end{aligned} \tag{3.13}$$

where

$$\begin{aligned}
 v_{1,0}(t) = x_0(t) = x(0) &= r_1, \\
 v_{2,0}(t) = y_0(t) = y(0) &= r_2, \\
 v_{3,0}(t) = z_0(t) = z(0) &= r_3,
 \end{aligned} \tag{3.14}$$

in order to fulfil initial conditions from (3.12).

According to the HPM method and (2.7), every variable in (3.13) can be approximated as

$$\begin{aligned}
 v_1 &= v_{1,0} + pv_{1,1} + p^2v_{1,2} + p^3v_{1,3} + \dots, \\
 v_2 &= v_{2,0} + pv_{2,1} + p^2v_{2,2} + p^3v_{2,3} + \dots, \\
 v_3 &= v_{3,0} + pv_{3,1} + p^2v_{3,2} + p^3v_{3,3} + \dots.
 \end{aligned} \tag{3.15}$$

Substituting (3.15) into (3.13) and arranging coefficients with  $p$  powers, we construct and solve the following system having 12 equations and 12 unknowns

$$\begin{aligned}
 \frac{dv_{11}}{dt} - r_2 = 0, v_{11}(t^*) = 0, \frac{dv_{12}}{dt} - v_{21} = 0, v_{12}(t^*) = 0, \\
 \frac{dv_{13}}{dt} - v_{22} = 0, v_{13}(t^*) = 0, \frac{dv_{14}}{dt} - v_{23} = 0, v_{14}(t^*) = 0, \\
 \frac{dv_{21}}{dt} + \frac{1}{2}r_3^2r_2 + \frac{1}{3}r_1 - \frac{1}{2}r_2 = 0, v_{21}(t^*) = 0, \\
 \frac{dv_{22}}{dt} + r_3v_{31}r_2 + \frac{1}{2}r_3^2v_{21} - \frac{1}{2}v_{21} + \frac{1}{3}v_{11} = 0, v_{22}(t^*) = 0, \\
 \frac{dv_{23}}{dt} + r_3v_{32}r_2 + \frac{1}{3}v_{12} + \frac{1}{2}r_3^2v_{22} + r_3v_{31}v_{21} - \frac{1}{2}v_{22} \\
 + \frac{1}{2}v_{31}^2r_2 = 0, v_{23}(t^*) = 0, \\
 \frac{dv_{24}}{dt} + \frac{1}{3}v_{13} + v_{31}v_{32}r_2 + r_3v_{32}v_{21} + \frac{1}{2}r_3^2v_{23} + \frac{1}{2}v_{31}^2v_{21} - \frac{1}{2}v_{23} + r_3v_{33}r_2 \\
 + r_3v_{31}v_{22} = 0, v_{24}(t^*) = 0, \\
 \frac{dv_{31}}{dt} + 0.6r_3 + r_2 - r_2r_3 = 0, v_{31}(t^*) = 0, \\
 \frac{dv_{32}}{dt} - r_2v_{31} - v_{21}r_3 + .6v_{31} + v_{21} = 0, v_{32}(t^*) = 0, \\
 \frac{dv_{33}}{dt} - r_2v_{32} + 0.6v_{32} - v_{21}v_{31} + v_{22} - v_{22}r_3 = 0, v_{33}(t^*) = 0, \\
 \frac{dv_{34}}{dt} - r_2v_{33} - v_{21}v_{32} + v_{23} + 0.6v_{33} - v_{23}r_3 - v_{22}v_{31} = 0, v_{34}(t^*) = 0.
 \end{aligned}
 \tag{3.16}$$

Following the MuHPM method, the step size is set at  $\Delta t = 0.1$ ,  $t_i = 0$  as initial point, and final tracing point as  $t_f = 100$  and  $M = 1000$ . Next, the first three iterations for the MuHPM method are shown

1. First, we solve (3.16) to obtain the following four order approximation (see equation 3.15)

$$\begin{aligned}
 x(t) &= \lim_{p \rightarrow 1} v_1(t) = \lim_{p \rightarrow 1} \left( \sum_{k=0}^4 p^k v_{1,k}(t) \right), \\
 y(t) &= \lim_{p \rightarrow 1} v_2(t) = \lim_{p \rightarrow 1} \left( \sum_{k=0}^4 p^k v_{2,k}(t) \right), \\
 z(t) &= \lim_{p \rightarrow 1} v_3(t) = \lim_{p \rightarrow 1} \left( \sum_{k=0}^4 p^k v_{3,k}(t) \right).
 \end{aligned}
 \tag{3.17}$$

Expression (3.17) is too cumbersome to be written here, nonetheless, we will show the particular solutions for each segment of MuHPM.

2. For  $k = 0$ . We set  $t^* = 0$ ,  $r_1 = 0.1$ ,  $r_2 = 0.1$ , and  $r_3 = 0$  in (3.17), to obtain segment 0

$$\begin{aligned}
 x_{s0}(t) &= 0.1 + 0.1t + 0.008333333333t^2 - 0.004166666666t^3 \\
 &\quad - 0.000793981481t^4, \\
 y_{s0}(t) &= 0.1 + 0.0166666666667t - 0.0125t^2 - 0.00317592592t^3 \\
 &\quad - 0.000028935185t^4, \\
 z_{s0}(t) &= -0.1t + 0.0166666666667t^2 + 0.0008333333333t^3 \\
 &\quad + 0.00107175925926t^4,
 \end{aligned}
 \tag{3.18}$$

Evaluating (3.18) at  $t = 0.1$ , we obtain the following prediction

$x_{s_0}(0.1) = 0.110079087269$ ,  $y_{s_0}(0.1) = 0.101538487847$ , and  $z_{s_0}(0.1) = -0.009832392824$ . Besides, (3.18) would be the result of applying the standard HPM method [58] to solve (3.12).

3. For  $k = 1$ . We set  $t^* = 0.1$ ,  $r_1 = x_{s_0}(0.1)$ ,  $r_2 = y_{s_0}(0.1)$ , and  $r_3 = z_{s_0}(0.1)$  in (3.17), in order to obtain segment 1

$$\begin{aligned} x_{s_1}(t) &= .100000000111 + 0.09999999951t + 0.008333326655t^2 \\ &\quad - 0.004166543972t^3 - 0.000795168818t^4, \\ y_{s_1}(t) &= 0.016666631327t + .100000000063 - 0.012499302163t^2 \\ &\quad - 0.003182873641t^3 + 0.549591616344E-5t^4, \\ z_{s_1}(t) &= -8.0420E-11 - 0.0999999582585t + 0.01666584134t^2 \\ &\quad + 0.000841521281t^3 + 0.001031474990t^4, \end{aligned} \tag{3.19}$$

Evaluating (3.19) at  $t = 0.2$ , the next prediction is

$x_{s_1}(0.2) = 0.120298728458$ ,  $y_{s_1}(0.2) = 0.102807900043$ , and  $z_{s_1}(0.2) = -0.019324975548$ .

4. For  $k = 2$ . We set  $t^* = 0.2$ ,  $r_1 = x_{s_1}(0.2)$ ,  $r_2 = y_{s_1}(0.2)$ , and  $r_3 = z_{s_1}(0.2)$ . Updating (3.17), we obtain the approximate solution for segment 2. Furthermore, the process is repeated until  $t^* > t_f$  or  $k > M$ .

The initial condition and predictions generated by the MuHPM process traces the trajectory for the differential equation in (3.12); which successfully describes the memristive chaotic circuit.

#### 4 Numerical Simulation and Discussion

As explained in previous sections, MuHPM is a numerical-analytical method that divides the chaotic behaviour into a series of segments to obtain a set of analytical approximations (one by segment) that, as a whole, serve to track the path of the non-linear differential equation of the memristive circuit ((3.18) and (3.19)).

Figures 2(a), 2(b), and 2(c) show how MuHPM accurately trace the curves  $x(t)$ ,  $y(t)$ , and  $z(t)$ . In order to provide a reference point, the obtained results were compared to the numerical solution obtained using the Fehlberg fourth-fifth order Runge-Kutta method with degree four interpolant (RKF45) [93, 94] built-in routine from Maple 13 Software. The routine was configured using an absolute error of  $10^{-7}$  and a relative error of  $10^{-6}$ . According to the results depicted in Figures 3(a) and 3(b), can be seen that the chaotic behaviour of the circuit in Fig. 1 is accurately calculated by the MuHPM method.

Tables 1, 2 and 3 show the dynamic behaviour of variables  $x(t)$ ,  $y(t)$ , and  $z(t)$  respectively to show, quantitatively, a comparison of the MuHPM, the basic HPM (3.18) and the RKF45 methods. From the tables can be noticed that the HPM method rapidly loses accuracy after  $t = 3s$  while MuHPM remains accurate up to  $t = 100s$  (see the relative error column), using as reference the results from applying the RKF45 method. The relative error (RE) increases gradually for all three variables, starting with an error of zero at  $t = 0$  until reaching their maximum value at  $t = 100s$ , that is,  $RE[x(100)] = -0.0185651$ ,  $RE[y(100)] = -0.000446$ , and  $RE[z(100)] = -0.000169$ . This increasing tendency of the error can be diminished by reducing the step size  $t$  or by improving the resultant approximations from the MuHPM method. In this work, the trial function ( $x_0(t)$ ,  $y_0(t)$ , and  $z_0(t)$ ) of the proposed HPM method was based in constants calculated from initial conditions and afterwards by predictive steps. Nevertheless, it is possible to propose a trial function more efficient, giving as result an increase of the path tracking range; this option will be addressed in a future work.

Finally, for a later work, we will improve the methodology in order to significantly decrease the number of segments required to complete the path tracking; this will lead to increase the qualitative understanding about how the circuital parameters affect the chaotic path for longer time segments.

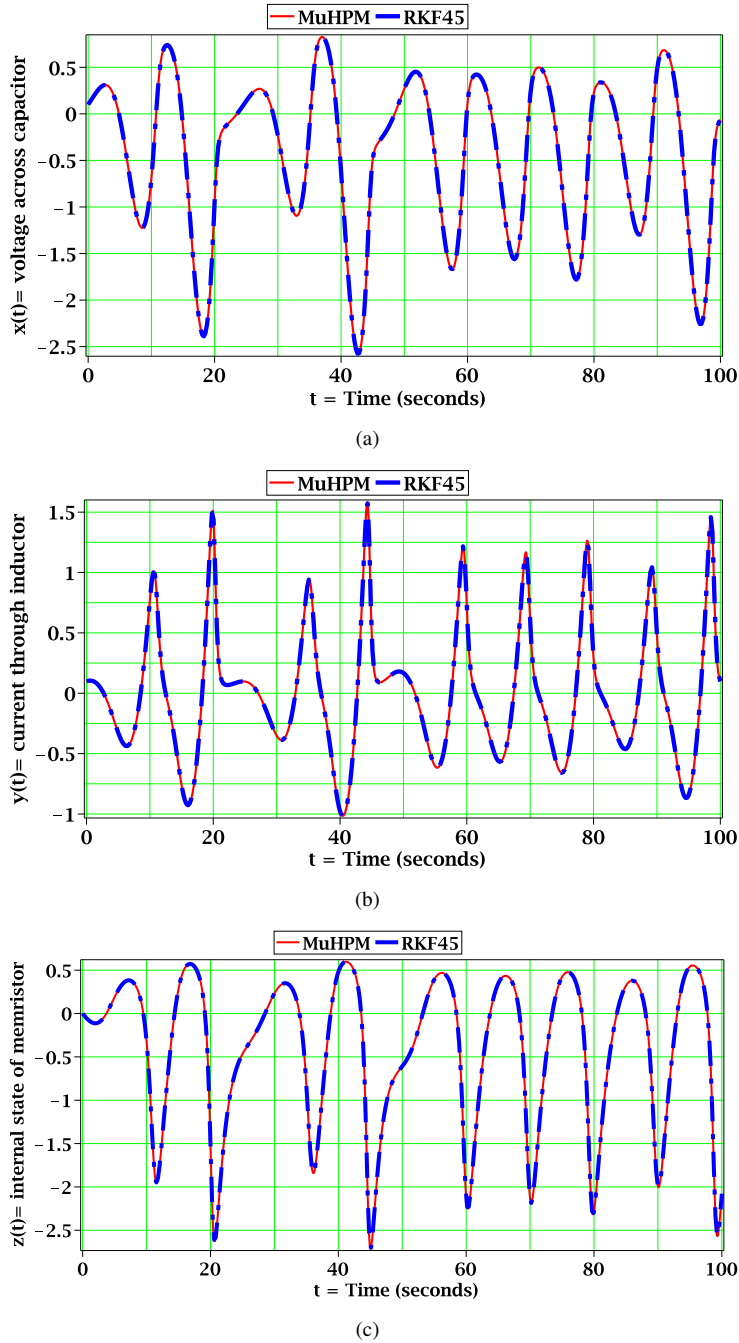
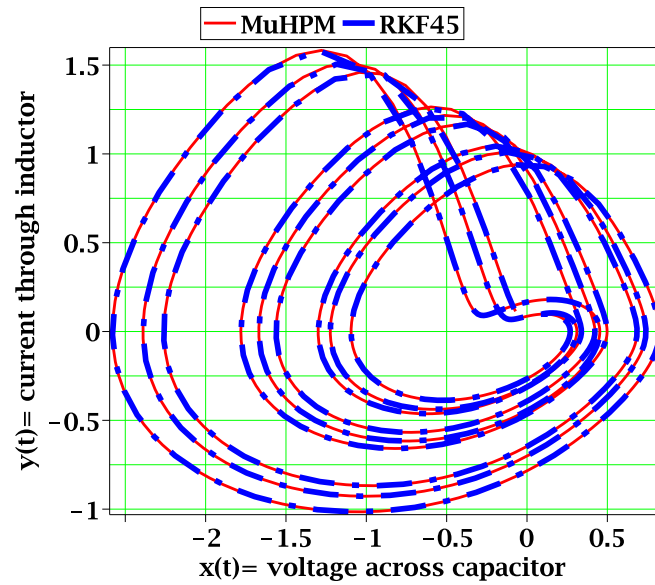
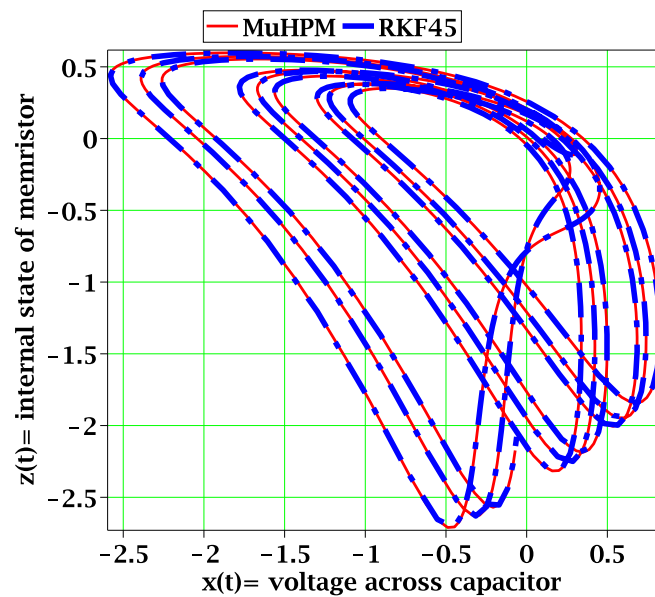

Figure 2: Path tracking for variables a)  $x(t)$ , b)  $y(t)$ , and c)  $z(t)$  from the differential equation of the chaotic memristive circuit. Time, in seconds, is given in the range of  $[0, 100]$ .





(a) Path tracking for  $x(t)-y(t)$



(b) Path tracking for  $x(t)-z(t)$

Figure 3: Paths for the chaotic circuit containing Memristor calculated using MuHPM (continuous line) and RKF45 (dashed line). Time, in seconds, is given in the range of  $[0, 100]$ .

$t$	MuHPM	HPM	RKF45	Relative Error
0.00*	0.100000000000	0.100000000000	0.100000000000	0.000000000000
0.10	0.110079087269	0.110079087269	0.110079086421	0.000000007695
0.20	0.120298728458	0.120298729630	0.120298724155	0.000000035772
0.40	0.141046327958	0.141046340741	0.141046323725	0.000000030010
0.80	0.182875982722	0.182874785185	0.182875974611	0.000000044355
1.00	0.203378837869	0.203372685185	0.203378823527	0.000000070520
3.00	0.305718760880	0.298187500000	0.305718783609	-0.000000074346
4.00	0.206504194694	0.163407407407	0.206504289111	-0.000000457219
5.00	-0.043266596321	-0.2087384259	-0.043266350794	0.000005674747
8.00	-1.170592436579	-3.9521481481	-1.170592466989	-0.000000025978
10.00	-0.695419650446	-10.173148148	-0.695422443741	-0.000004016704
20.00	-0.945002521428	-154.93703703	-0.945017919602	-0.000016294320
30.00	-0.233265692384	-745.02500000	-0.233272243142	-0.000028082816
50.00	0.269375020008	-5457.2842592	0.269392158892	-0.000063624621
70.00	0.254343941220	-20444.7287037	0.254406289432	-0.000245133467
100.00	-0.060559066640	-83471.381481	-0.061683355359	-0.018565159291

Table 1: Numerical path tracking (3.12) for voltage across capacitor  $x(t)$  by using MuHPM, HPM (3.18), and RKF45. The relative error is calculated from MuHPM and RKF45. Time is given in seconds. \*At  $t=0$ , the error is expressed as absolute error.

$t$	MuHPM	HPM	RKF45	Relative Error
0.00*	0.100000000000	0.100000000000	0.100000000000	0.000000000000
0.10	0.101538487847	0.101538487847	0.101538491360	-0.000000034598
0.20	0.102807900043	0.10280787963	0.102807906516	-0.000000062954
0.40	0.104463374390	0.104462666667	0.104463377498	-0.000000029758
0.80	0.103718813856	0.103695407407	0.103718825364	-0.000000110953
1.00	0.101034080285	0.100961805556	0.101034084188	-0.000000038636
3.00	-0.032886721969	-0.05059375000	-0.032886661610	0.000001835387
4.00	-0.171681208941	-0.24400000000	-0.171681107541	0.000000590629
5.00	-0.325990251363	-0.544241898148	-0.325990172567	0.000000241712
8.00	-0.191676695554	-2.31125925926	-0.191677058287	-0.000001892422
10.00	0.771986844312	-4.44861111111	0.771983020391	0.000004953350
20.00	1.476340347896	-34.6037037037	1.476468413169	-0.000086745088
30.00	-0.350692776287	-119.83750000	-0.350681308519	0.000032700325
50.00	0.168182847308	-608.152314815	0.168196427098	-0.000080744202
70.00	0.595184038800	-1844.05972222	0.595278584883	-0.000158851846
100.00	0.097351950300	-6192.67777778	0.097391339729	-0.000404608528

Table 2: Numerical path tracking (3.12) for current through inductor  $y(t)$  by using MuHPM, HPM (3.18), and RKF45. The relative error is calculated from MuHPM and RKF45. Time is given in seconds. \*At  $t=0$ , the error is expressed as absolute error.

$t$	MuHPM	HPM	RKF45	Relative Error
0.00*	0.000000000000	0.000000000000	0.000000000000	0.000000000000
0.10	-0.009832392824	-0.009832392824	-0.009832394654	-0.000000186141
0.20	-0.019324975548	-0.019324951852	-0.019324974914	0.000000032822
0.40	-0.037253399522	-0.037252562963	-0.037253403134	-0.000000096965
0.80	-0.068496653970	-0.068467674074	-0.068496667893	-0.000000203266
1.00	-0.081520266961	-0.081428240741	-0.081520269905	-0.000000036117
3.00	-0.073204466845	-0.040687500000	-0.073204521431	-0.000000745665
4.00	0.039945585312	0.194370370370	0.039945531733	0.000001341289
5.00	0.190476126786	0.690682870370	0.190476108878	0.000000094017
8.00	0.351138007655	5.083259259259	0.351138071694	-0.000000182375
10.00	-0.321206117603	12.217592592593	-0.321203789045	0.000007249421
20.00	-1.521808805572	182.8148148148	-1.521699428035	0.000071873377
30.00	0.231529303107	902.6250000000	0.231526168244	0.000013539810
50.00	-0.608498144889	6839.328703703	-0.608546966734	-0.000080233350
70.00	-2.135554762700	26093.43981481	-2.135410008407	0.000067782993
100.00	-2.078796951000	108165.9259259	-2.079149484448	-0.000169585321

Table 3: Numerical path tracking (3.12) for internal state of Memristor  $z(t)$  by using MuHPM, HPM (3.18), and RKF45. The relative error is calculated from MuHPM and RKF45. Time is given in seconds. \*At  $t=0$ , the error is expressed as absolute error.

## 5 Conclusions

In this work, a methodology to accurately predict the dynamic behaviour of chaotic memristive circuits using the multistage perturbation method was proposed. As shown in the previous analyses, the proposed methodology provides a semi-analytical solution which is easily manipulable to obtain both, the quantitative and qualitative information of the dynamics of the memristive circuit. According to a comparison against similar methodologies, the proposed solution has proven to be highly accurate along the simulation time ( $t \in [0, 100]$ ). While after this range the accuracy begins to decrease, future work aims to increase the precision within a wider range of time by changing the homotopy map and by augmenting the order of the HPM approximation.

## Acknowledgements

We gratefully acknowledge the financial support from the National Council for Science and Technology of Mexico (CONACyT) through grant CB-2010-01 #157024. The author wants to express his gratitude to Rogelio-Alejandro Callejas-Molina and Roberto Ruiz-Gomez for their contribution to this project.

## References

- [1] P. B. Agarwal, A. Kumar, Design and simulation of octal-to-binary encoder using capacitive single-electron transistors (C-SETs), *Microelectronics Journal*, 42 (1) (2011) 96-100.  
<http://dx.doi.org/10.1016/j.mejo.2010.08.021>
- [2] M. Troudi, Na. Sghaier, A. Boubaker, A. Souifi, A. Kalboussi, Macro-modeling for the compact simulation of single electron transistor using SIMPLORER, *Microelectronics Journal*, 38 (12) (2007) 1156-1160.  
<http://dx.doi.org/10.1016/j.mejo.2007.09.007>
- [3] A. Venkataratnam, A. K. Goel, Design and simulation of logic circuits with hybrid architectures of single-electron transistors and conventional MOS devices at room temperature, *Microelectronics Journal*, 39 (12) (2008) 1461-1468.  
<http://dx.doi.org/10.1016/j.mejo.2008.08.002>

- [4] L. A. Agapito, S. Alkis, J. L. Krause, H.-P. Cheng, Atomistic Origins of Molecular Memristors, *Journal of Physical Chemistry, C* 113 (2009) 20713-20718.  
<http://dx.doi.org/10.1021/jp9060347>
- [5] A. Bandyopadhyay, S. Sahu, M. Higuchi, Tuning of Nonvolatile Bipolar Memristive Switching in Co(III) Polymer with an Extended Azo Aromatic Ligand, *Journal of the American Chemical Society*, 133 (2011) 1168-1171.  
<http://dx.doi.org/10.1021/ja106945v>
- [6] T. Berzina, S. Erokhina, P. Camorani, O. Konovalov, V. Erokhin, M. P. Fontana, Electrochemical control of the conductivity in an organic memristor: a time-resolved X-ray fluorescence study of ionic drift as a function of the applied voltage, *ACS Applied Materials & Interfaces*, 1 (10) (2009) 2115-2118.  
<http://dx.doi.org/10.1021/am900464k>
- [7] T. Berzina, A. Smerieri, G. Ruggeri, M. Bernabo, V. Erokhin, M. P. Fontana, Role of the solid electrolyte composition on the performance of a polymeric memristor, *Materials Science and Engineering, C* 30 (3) (2010) 407-411.  
<http://dx.doi.org/10.1016/j.msec.2009.12.010>
- [8] L. O. Chua, Synthesis of new nonlinear network elements, *Proceedings of the IEEE*, 56(8) (1968) 1325-1340.  
<http://dx.doi.org/10.1109/PROC.1968.6574>
- [9] L. O. Chua, Memristor - The missing circuit element, *IEEE Transactions on Circuit Theory*, 18 (5) (1971) 507-519.  
<http://dx.doi.org/10.1109/TCT.1971.1083337>
- [10] L. O. Chua, S. M. Kang, Memristive devices and systems, *Proceedings of the IEEE*, 64 (2) (1976) 209-223.  
<http://dx.doi.org/10.1109/PROC.1976.10092>
- [11] L. O. Chua, Global unfolding of Chua's circuit, *IEICE Transactions on Fundamentals of Electronics, Communications and Computer Sciences*, E76-A (5) (1993) 704-734.
- [12] N. Duraisamy, N. M. Muhammad, H.-C. Kim, J.-D. Jo, K.-H. Choi, Fabrication of TiO<sub>2</sub> thin film memristor device using electrohydrodynamic inkjet printing, *Thin Solid Films In Press*, (2012).  
<http://dx.doi.org/10.1016/j.tsf.2012.03.003>
- [13] V. Erokhin, T. Berzina, A. Smerieri, P. Camorani, S. Erokhina, M. P. Fontana, Bio-inspired adaptive networks based on organic memristors, *Nano Communication Networks*, 1 (2) (2010) 108-117.  
<http://dx.doi.org/10.1016/j.nancom.2010.05.002>
- [14] K. Gorshkov, T. Berzina, V. Erokhin, M. P. Fontana, Organic Memristor Based on the Composite Materials: Conducting and Ionic Polymers, Gold Nanoparticles and Graphenes, *Procedia Computer Science*, 7 (2011) 248-249.  
<http://dx.doi.org/10.1016/j.procs.2011.09.020>
- [15] T. H. Kim, E. Y. Jang, N. J. Lee, D. J. Choi, K.-J. Lee, J.-T. Jang, J.-S. Choi, S. H. Moon, J. Cheon, Nanoparticle Assemblies as Memristors, *Nano Letters*, 9 (6) (2009) 2229-2233.  
<http://dx.doi.org/10.1021/nl900030n>
- [16] P. Marks, Missing memristor makes an appearance, *The New Scientist*, 198 (2654) (2008) 26 pages.  
[http://dx.doi.org/10.1016/S0262-4079\(08\)61099-4](http://dx.doi.org/10.1016/S0262-4079(08)61099-4)
- [17] K. McAlpine, Sweat ducts make skin a memristor, *The New Scientist*, 209 (2802) (2011) 16 pages.  
[http://dx.doi.org/10.1016/S0262-4079\(11\)60481-8](http://dx.doi.org/10.1016/S0262-4079(11)60481-8)
- [18] F. Merrikh-Bayat, S. B. Shouraki, Programming of memristor crossbars by using genetic algorithm, *Procedia Computer Science*, 3 (2011) 232-237.  
<http://dx.doi.org/10.1016/j.procs.2010.12.039>

- [19] F. Merrikh-Bayat, S. B. Shouraki, Memristor-based circuits for performing basic arithmetic operations, *Procedia Computer Science*, 3 (2011) 128-132.  
<http://dx.doi.org/10.1016/j.procs.2010.12.022>
- [20] F. Miao, W. Yi, I. Goldfarb, J. J. Yang, M.-X. Zhang, M. D. Pickett, J. P. Strachan, G. Medeiros-Ribeiro, R. S. Williams, Continuous Electrical Tuning of the Chemical Composition of TaOx-Based Memristors, *ACS Nano*, 6 (3) (2012) 2312-2318.  
<http://dx.doi.org/10.1021/nl2044577>
- [21] K. Nagashima, T. Yanagida, K. Oka, M. Kanai, A. Klamchuen, J.-S. Kim, B. H. Park, T. Kawai, Intrinsic Mechanisms of Memristive Switching, *Nano Letters*, 11 (2011) 2114-2118.  
<http://dx.doi.org/10.1021/nl200707n>
- [22] W. I. Park, J. M. Yoon, M. Park, J. Lee, S. K. Kim, J. W. Jeong, K. Kim, H. Y. Jeong, S. Jeon, K. S. No, J. Y. Lee, Y. S. Jung, Self-Assembly-Induced Formation of High-Density Silicon Oxide Memristor Nanostructures on Graphene and Metal Electrodes, *Nano Letters*, 12 (2012) 1235-1240.  
<http://dx.doi.org/10.1021/nl203597d>
- [23] G. E. Paziienza, R. Kozma, Memristor as an archetype of dynamic data-driven systems and applications to sensor networks, *Procedia Computer Science*, 4 (2011) 1782-1787.  
<http://dx.doi.org/10.1016/j.procs.2011.04.193>
- [24] I. Petras, Fractional-order memristor-based Chua's circuit, *IEEE Transactions on Circuits and Systems II: Express Briefs*, 57 (12) (2010) 975-979.  
<http://dx.doi.org/10.1109/TCSII.2010.2083150>
- [25] R. Riaza, Dynamical properties of electrical circuits with fully nonlinear memristors, *Nonlinear Analysis: Real World Applications*, 12 (6) (2011) 3674-3686.  
<http://dx.doi.org/10.1016/j.nonrwa.2011.06.024>
- [26] R. Sigala, A. Smerieri, V. Erokhin, Adaptive Properties of Stochastic Memristor Networks: A Computational Study, *Procedia Computer Science*, 7 (2011) 312-313.  
<http://dx.doi.org/10.1016/j.procs.2011.09.021>
- [27] X. Y. Wang, A. L. Fitch, H. H. C. Iu, W. G. Qi, Design of a memcapacitor emulator based on a memristor, *Physics Letters, A* 376 (4) (2012) 394-399.  
<http://dx.doi.org/10.1016/j.physleta.2011.11.012>
- [28] A. Wu, J. Zhang, Z. Zeng, Dynamic behaviors of a class of memristor-based Hopfield networks, *Physics Letters, A* 375 (15) (2011) 1661-1665.  
<http://dx.doi.org/10.1016/j.physleta.2011.02.068>
- [29] Q. Xia, W. Robinett, M. W. Cumbie, N. Banerjee, T. J. Cardinali, J. J. Yang, W. Wu, X. Li, W. M. Tong, D. B. Strukov, G. S. Snider, G. Medeiros-Ribeiro, R. S. Williams, Memristor-CMOS Hybrid Integrated Circuits for Reconfigurable Logic, *Nano Letters*, 9 (10) (2009) 3640-3645.  
<http://dx.doi.org/10.1021/nl901874j>
- [30] Q. Xia, J. J. Yang, W. Wu, X. Li, R. S. Williams, Self-Aligned Memristor Cross-Point Arrays Fabricated with One Nanoimprint Lithography Step, *Nano Letters*, 10 (2010) 2909-2914.  
<http://dx.doi.org/10.1021/nl1017157>
- [31] J. J. Yang, N. P. Kobayashi, J. P. Strachan, M.-X. Zhang, A. A. Ohlberg, M. D. Pickett, Z. Li, G. Medeiros-Ribeiro, R. S. Williams, Dopant Control by Atomic Layer Deposition in Oxide Films for Memristive Switches, *Chemistry of Materials*, 23 (2011) 123-125.  
<http://dx.doi.org/10.1021/cm1020959>

- [32] A. A. Zakhidov, B. Jung, J. D. Slinker, H. D. Abruña, G. G. Malliaras, A light-emitting memristor, *Organic Electronics*, 11 (1) (2010) 150-153.  
<http://dx.doi.org/10.1016/j.orgel.2009.09.015>
- [33] V. M. Jimenez-Fernandez, J. A. Dominguez-Chavez, H. Vazquez-Leal, A. Gallardo-del-Angel, Z. J. Hernandez-Paxtian, Descripción del modelo eléctrico del memristor, *Revista Mexicana de Fisica*, E 58 (2) (2012) (113-119).
- [34] T. Chang, S-H Jo, K-H Kim, P. Sheridan, S. Gaba, W. Lu, Synaptic behaviors and modeling of a metal oxide memristive device, *Applied Physics*, A 102 (4) (2011) 857-863.  
<http://dx.doi.org/10.1007/s00339-011-6296-1>
- [35] S. H. Jo, T. Chang, I. Ebong, B. B. Bhadviya, P. Mazumder, W. Lu, Nanoscale Memristor Device as Synapse in Neuromorphic Systems, *Nano Letters*, 10 (2010) 1297-1301.  
<http://dx.doi.org/10.1021/nl904092h>
- [36] K.-H. Kim, S. Gaba, D. Wheeler, J. M. Cruz-Albrecht, T. Hussain, N. Srinivasa, W. Lu, A Functional Hybrid Memristor Crossbar-Array/CMOS System for Data Storage and Neuromorphic Applications, *Nano Letters*, 12 (2012) 389-395.  
<http://dx.doi.org/10.1021/nl203687n>
- [37] E. Lehtonen, M. Laiho, CNN using memristors for neighborhood connections, in: 12th International Workshop on Cellular Nanoscale Networks and their Applications (CNNA), Berkeley, United States, (2010) 1-4.  
<http://dx.doi.org/10.1109/CNNA.2010.5430304>
- [38] J. Mullins, Memristor minds, *The New Scientist*, 203 (2715) (2010) 42-45.  
[http://dx.doi.org/10.1016/S0262-4079\(09\)61784-X](http://dx.doi.org/10.1016/S0262-4079(09)61784-X)
- [39] A. Wu, Z. Zeng, X. Zhu, J. Zhang, Exponential synchronization of memristor-based recurrent neural networks with time delays, *Neurocomputing*, 74 (17) (2011) 3043-3050.  
<http://dx.doi.org/10.1016/j.neucom.2011.04.016>
- [40] A. Wu, S. Wen, Z. Zeng, Synchronization control of a class of memristor-based recurrent neural networks, *Information Sciences*, 183 (1) (2012) 106-116.  
<http://dx.doi.org/10.1016/j.ins.2011.07.044>
- [41] T. Chang, S.-H. Jo, W. Lu, Short-Term Memory to Long-Term Memory Transition in a Nanoscale Memristor, *ACS Nano*, 5 (9) (2011) 7669-7676.  
<http://dx.doi.org/10.1021/nn202983n>
- [42] N. Gergel-Hackett, B. Hamadani, B. Dunlap, J. Suehle, C. Richter, C. Hacker, D. Gundlach, A flexible solution-processed memristor, *IEEE Electron Device Letters*, 30 (7) (2009) 706-708.  
<http://dx.doi.org/10.1109/LED.2009.2021418>
- [43] S. Kim, H. Y. Jeong, S. K. Kim, S.-Y. Choi, K. J. Lee, Flexible Memristive Memory Array on Plastic Substrates, *Nano Letters*, 11 (2011) 5438-5442.  
<http://dx.doi.org/10.1021/nl203206h>
- [44] X. F. Hu, S. K. Duan, L. D. Wang, X. Liao, Memristive crossbar array with applications in image processing, *Science China Information Sciences*, 55 (2) (2011) 461-472.  
<http://dx.doi.org/10.1007/s11432-011-4410-9>
- [45] A. Talukdar, A. G. Radwan, K. N. Salama, A memristor-based third-order oscillator: beyond oscillation, *Applied Nanoscience*, 1 (3) (2011) 143-145.  
<http://dx.doi.org/10.1007/s13204-011-0021-4>

- [46] A. Talukdar, A. G. Radwan, K. N. Salama, Generalized model for Memristor-based Wien family oscillators, *Microelectronics Journal*, 42 (9) (2011) 1032-1038.  
<http://dx.doi.org/10.1016/j.mejo.2011.07.001>
- [47] A. Talukdar, A. G. Radwan, K. N. Salama, Non linear dynamics of memristor based 3rd order oscillatory system, *Microelectronics Journal*, 43 (2012) (3) 169-175.  
<http://dx.doi.org/10.1016/j.mejo.2011.12.012>
- [48] B. C. Bao, G. D. Shi, J. P. Xu, Z. Liu, S. H. Pan, Dynamics analysis of chaotic circuit with two memristors, *Science China Technological Sciences*, 54 (8) (2011) 2180-2187.  
<http://dx.doi.org/10.1007/s11431-011-4400-6>
- [49] T. Driscoll, Y. V. Pershin, D. N. Basov, M. Di Ventra, Chaotic memristor, *Applied Physics-A*, 102 (2011) 885-889.  
<http://dx.doi.org/10.1007/s00339-011-6318-z>
- [50] Z. Hu, Y. Li, L. Jia, J. Yu, Chaos in a charge-controlled memcapacitor circuit, in: *International Conference on Communications, Circuits and Systems (ICCCAS)*, Chengdu, China, 2010 828-831.
- [51] B. Muthuswamy, L. O. Chua, Simplest chaotic circuit, *International Journal of Bifurcation and Chaos*, 20 (5) (2010) 1567-1580.  
<http://dx.doi.org/10.1142/S0218127410027076>
- [52] W. Sun, C. Li, J. Yu, A memristor based chaotic oscillator, in: *International Conference on Communications, Circuits and Systems (ICCCAS)*, Milpitas, United States, (2009) 955-957.
- [53] W. Wang, Q. Yu, C. Xu, Y. Cui, Study of filter characteristics based on PWL memristor, in: *International Conference on Communications, Circuits and Systems (ICCCAS)*, Milpitas, United States, (2009) 969-973.
- [54] C.-Y. Huang, W. C. Shen, Y.-H. Tseng, Y.-C. King, C.-J. Lin, A Contact-Resistive Random-Access-Memory-Based True Random Number Generator, *IEEE Electron Device Letters*, 33 (8) (2012) 1108-1110.  
<http://dx.doi.org/10.1109/LED.2012.2199734>
- [55] M. S. H. Chowdhury, I. Hashim, S. Momani, The multistage homotopy-perturbation method: A powerful scheme for handling the Lorenz system, *Chaos, Solitons and Fractals*, 40 (2009) 1929-1937.  
<http://dx.doi.org/10.1016/j.chaos.2007.09.073>
- [56] M. Fathizadeh, M. Madani, Y. Khan, N. Faraz, A. Yıldırım, S. Tutkun, An effective modification of the homotopy perturbation method for MHD viscous flow over a stretching sheet, *Journal of King Saud University - Science*, 25 (2) (2013) 107-113.  
<http://dx.doi.org/10.1016/j.jksus.2011.08.003>
- [57] U. Filobello-Nino, H. Vazquez-Leal, R. Castaneda-Sheissa, A. Yildirim, L. Hernandez-Martinez, D. Pereyra-Diaz, A. Perez-Sesma, C. Hoyos-Reyes, An approximate solution of Blasius equation by using HPM method, *Asian Journal of Mathematics and Statistics*, 2012 (2012) 10 pages.
- [58] J. H. He, Homotopy perturbation technique, *Computer Methods in Applied Mechanics and Engineering*, 178 (3-4) (1999) 257-262.  
[http://dx.doi.org/10.1016/S0045-7825\(99\)00018-3](http://dx.doi.org/10.1016/S0045-7825(99)00018-3)
- [59] J. H. He, A coupling method of a homotopy technique and a perturbation technique for non-linear problems, *International Journal of Non-Linear Mechanics*, 35 (1) (2000) 37-43.  
[http://dx.doi.org/10.1016/S0020-7462\(98\)00085-7](http://dx.doi.org/10.1016/S0020-7462(98)00085-7)
- [60] Y. Khan, Q. Wu, Homotopy perturbation transform method for nonlinear equations using He's polynomials, *Computers and Mathematics with Applications*, 61 (8) (2011) 1963-1967.  
<http://dx.doi.org/10.1016/j.camwa.2010.08.022>

- [61] M. Madani, M. Fathizadeh, Y. Yasir Khan, A. Yildirim, On the coupling of the homotopy perturbation method and Laplace transformation, *Mathematical and Computer Modelling*, 53 (9-10) (2011) 1937-1945.  
<http://dx.doi.org/10.1016/j.mcm.2011.01.023>
- [62] S. Momani, A. Yildirim, Analytical approximate solutions of the fractional convection diffusion equation with nonlinear source term by He's homotopy perturbation method, *International Journal of Computer Mathematics*, 87 (5) (2010) 1057-1065.  
<http://dx.doi.org/10.1080/00207160903023581>
- [63] H. Vazquez-Leal, U. Filobello-Nino, R. Castaneda-Sheissa, L. Hernandez-Martinez, A. Sarmiento-Reyes, Modified HPMs inspired by homotopy continuation methods, *Mathematical Problems in Engineering*, 2012 (Article ID 309123) (2012) 20 pages.  
<http://dx.doi.org/10.1155/2012/309123>
- [64] H. Vazquez-Leal, R. Castaneda-Sheissa, U. Filobello-Nino, A. Sarmiento-Reyes, J. Sanchez-Orea, High accurate simple approximation of normal distribution related integrals, *Mathematical Problems in Engineering*, 2012 (Article ID 124029) (2012) 22 pages.  
<http://dx.doi.org/10.1155/2012/124029>
- [65] A. Yildirim, Analytical approximate solution of a SIR epidemic model with constant vaccination strategy by homotopy perturbation method, *Kybernetes*, 38 (9) (2009) 1566-1575.  
<http://dx.doi.org/10.1108/03684920910991540>
- [66] A. Yildirim, Analytical approach to fractional partial differential equations in fluid mechanics by means of the homotopy perturbation method, *International Journal of Numerical Methods for Heat and Fluid Flow*, 20 (2) (2010) 186-200.  
<http://dx.doi.org/10.1108/09615531011016957>
- [67] A. Yildirim, H. Koçak, An efficient technique for solving the Blaszk-Marciniak lattice by combining Homotopy Perturbation and Pade techniques, *International Journal of Computational Methods*, 9 (2) (2012) 16 pages.  
<http://dx.doi.org/10.1142/S0219876212400245>
- [68] H. Vazquez-Leal, Y. Khan, Guillermo Fernandez-Anaya, A. Herrera-May, A. Sarmiento-Reyes, U. Filobello-Nino, V. M. Jimenez-Fernandez, D. Pereyra-Diaz, A General Solution for Troesch's Problem, *Mathematical Problems in Engineering*, 2012 (2012) 1-14.  
<http://dx.doi.org/10.1155/2012/208375>
- [69] H. Vazquez-Leal, A. Sarmiento-Reyes, Y. Khan, U. Filobello-Nino, A. Diaz-Sanchez, Rational Biparameter Homotopy Perturbation Method and Laplace-Padé Coupled Version, *Journal of Applied Mathematics*, 2012 (2012) 1-21.  
<http://dx.doi.org/10.1155/2012/923975>
- [70] H. Vazquez-Leal, Rational homotopy perturbation method, *Journal of Applied Mathematics*, 2012 (2012) 1-14.  
<http://dx.doi.org/10.1155/2012/490342>
- [71] H. Vazquez-Leal, Generalized Homotopy Method for Solving Nonlinear Differential Equations, *Computational and Applied Mathematics*, 2013 (2013) 1-14.  
<http://dx.doi.org/10.1007/s40314-013-0060-4>
- [72] V. Marinca, N. Herisanu, *Nonlinear dynamical systems in engineering: some approximate approaches*, Springer-Verlag, Berlin, 2011978-3-642-22734-9.
- [73] H. Vazquez-Leal, U. Filobello-Nino, A. Yildirim, L. Hernandez-Martinez, R. Castaneda-Sheissa, J. Sanchez-Orea, J. E. Molinar-Solis, A. Diaz-Sanchez, Transient and DC approximate expressions for diode circuits, *IEICE Electronic Express*, 9 (6) (2012) 522-530.  
<http://dx.doi.org/10.1587/elex.9.522>



- [74] S. Di Rocco, D. Eklund, C. Peterson, A. J. Sommese, Chern numbers of smooth varieties via homotopy continuation and intersection theory, *Journal of Symbolic Computation*, 46 (1) (2011) 23-33.  
<http://dx.doi.org/10.1016/j.jsc.2010.06.026>
- [75] L. B. Goldgeisser, M. M. Green, A novel algorithm that finds multiple operating points of nonlinear circuits automatically, in: *Proceedings of the 1998 IEEE International Symposium on Circuits and Systems, Monterey, USA, (1998)* 558-561.  
<http://dx.doi.org/10.1109/ISCAS.1998.704073>
- [76] L. B. Goldgeisser, M. M. Green, A Method for Automatically finding Multiple Operating Points in Nonlinear Circuits, *IEEE transactions on circuits and systems-I: fundamental theory and applications*, 52 (4) (2005) 776-784.  
<http://dx.doi.org/10.1109/TCSI.2005.844359>
- [77] F. Jalali, J. D. Seader, S. Khaleghi, Global solution approaches in equilibrium and stability analysis using homotopy continuation in the complex domain, *Computers & Chemical Engineering*, 32 (10) (2008) 2333-2345.  
<http://dx.doi.org/10.1016/j.compchemeng.2007.12.001>
- [78] I. Malinen, J. Tanskanen, Homotopy parameter bounding in increasing the robustness of homotopy continuation methods in multiplicity studies, *Computers & Chemical Engineering*, 34 (11) (2010) 1761-1774.  
<http://dx.doi.org/10.1016/j.compchemeng.2010.03.013>
- [79] J. Ogrodzki, *Circuit simulation: methods and algorithms*, CRC Press Inc, Boca Raton.
- [80] J. Roychowdhury, R. Melville, Delivering global DC convergence for large mixed-signal circuits via homotopy/continuation methods, *IEEE Transactions on Computer-Aided Design of Integrated Circuits and Systems*, 25 (1) (2006) 66-78.  
<http://dx.doi.org/10.1109/TCAD.2005.852461>
- [81] A. Sarmiento-Reyes, R. S. Murphy-Arteaga, H. Vazquez-Leal, A MAPLE-based homotopic circuit simulation package, in: *Proceedings of the 44th IEEE Midwest Symposium on Circuits and Systems, Dayton, United States, (2001)* 33-36.  
<http://dx.doi.org/10.1109/MWSCAS.2001.986108>
- [82] S. M. Varedi, H. M. Daniali, D. D. Ganji, Kinematics of an offset 3-UPU translational parallel manipulator by the homotopy continuation method, *Nonlinear Analysis: Real World Applications*, 10 (3) (2009) 1767-1774.  
<http://dx.doi.org/10.1016/j.nonrwa.2008.02.014>
- [83] H. Vazquez-Leal, L. Hernandez-Martinez, A. Sarmiento-Reyes, R. Castaneda-Sheissa, Numerical continuation scheme for tracing the double bounded homotopy for analysing nonlinear circuits, in: *Proceedings 2005 International Conference on Communications, Circuits and Systems, Hong Kong, China, (2005)* 1122-1126.  
<http://dx.doi.org/10.1109/ICCCAS.2005.1495304>
- [84] H. Vazquez-Leal, L. Hernandez-Martinez, A. Sarmiento-Reyes, Double-Bounded Homotopy for analysing nonlinear resistive circuits, in: *Proceedings IEEE International Symposium on Circuits and Systems, Kobe, Japan, (2005)* 3203-3206.  
<http://dx.doi.org/10.1109/ISCAS.2005.1465309>
- [85] H. Vazquez-Leal, L. Hernandez-Martinez, A. Sarmiento-Reyes, R. Castañeda-Sheissa, A. Gallardo-Del-Angel, Homotopy method with a formal stop criterion applied to circuit simulation, *IEICE Electronic Express*, 8 (21) (2011) 1808-1815.  
<http://dx.doi.org/10.1587/elex.8.1808>
- [86] H. Vazquez-Leal, R. Castaneda-Sheissa, F. Rabago-Bernal, L. Hernandez-Martinez, A. Sarmiento-Reyes, U. Filobello-Nino, Powering multiparameter homotopy-based simulation with a fast path-following technique, *ISRN Applied Mathematics*, 2011 (Article ID 610637) (2011) 7 pages.  
<http://dx.doi.org/10.5402/2011/610637>

- [87] T.-M. Wu, A study of convergence on the Newton-homotopy continuation method, *Applied Mathematics and Computation*, 168 (2) (2005) 1169-1174.  
<http://dx.doi.org/10.1016/j.amc.2003.10.068>
- [88] T.-M. Wu, Solving the nonlinear equations by the Newton-homotopy continuation method with adjustable auxiliary homotopy function, *Applied Mathematics and Computation*, 173 (1) (2006) 383-388.  
<http://dx.doi.org/10.1016/j.amc.2005.04.095>
- [89] T.-M. Wu, The inverse kinematics problem of spatial 4P3R robot manipulator by the homotopy continuation method with an adjustable auxiliary homotopy function, *Nonlinear Analysis: Theory, Methods & Applications*, 64 (10) (2006) 2373-2380.
- [90] K. Yamamura, T. Sekiguchi, Y. Inuoe, A fixed-point homotopy method for solving modified nodal equations, *IEEE Transactions on Circuits and Systems-I: Fundamental Theory and Applications*, 46 (6) (1999) 654-664.  
<http://dx.doi.org/10.1109/81.768822>
- [91] J. Biazar, H. Aminikhah, Study of convergence of homotopy perturbation method for systems of partial differential equations, *Computers and Mathematics with Applications*, 58 (11-12) (2009) 2221-2230.  
<http://dx.doi.org/10.1016/j.camwa.2009.03.030>
- [92] J. Biazar, H. Ghazvini, Convergence of the homotopy perturbation method for partial differential equations, *Nonlinear Analysis: Real World Applications*, 10 (5) (2009) 2633-2640.  
<http://dx.doi.org/10.1016/j.nonrwa.2008.07.002>
- [93] W. H. Enright, K. R. Jackson, S. P. Norsett, P. G. Thomsen, Interpolants for Runge-Kutta Formulas, *ACM Transactions on Mathematical Software*, 12 (3) (1986) 193-218.  
<http://dx.doi.org/10.1145/7921.7923>
- [94] E. Fehlberg, Klassische Runge-Kutta-Formeln vierter und niedrigerer Ordnung mit Schrittweiten-Kontrolle und ihre Anwendung auf Waermeleitungsprobleme, *Computing*, 6 (1970) 61-71.  
<http://dx.doi.org/10.1007/BF02241732>