

APPLICATION OF SIMULATION TO SOLVE HUNTING PROBLEM IN VAV SYSTEM

Zheng Han¹, Yingxin Zhu¹, Chunhai Xia¹, and Guohai Xu²

¹Department of Building Science, School of Architecture, Tsinghua University,
Beijing 100084, China

² Yamatake Corporation, Japan

ABSTRACT

Variable Air Volume (VAV) system has been widely used in order to reduce energy consumption. However, operation performance and energy consumption may not be as good as expectation in practical projects due to some failures. Hunting of control parameters is one of the typical failures, which may result in dissatisfying the owner's requirements, abrading the actuators and reducing the service life of the equipment. In this paper, hunting problem is divided into three categories and several solutions are suggested. A practical VAV system in an office building in Beijing is analyzed, and some operation failures are found out. Furthermore, countermeasures are brought forward to improve operation efficiency. Finally, computer simulation is used to analyze and validate the effect of the new control strategy. This research may contribute to optimizing VAV control.

KEYWORDS

VAV, hunting, temperature set-point

INTRODUCTION

Variable Air Volume (VAV) system was originated in the United States in 1960s. Because of its comfort and agile performance, VAV system widely spreads abroad to Japan and European countries. In recent years, VAV system is more extensively used in China.

Hunting of control parameters is one of the usual problems in VAV system. Due to its nature of complex nonlinearity, randomness and significant crosscoupling, it is difficult to model and control such multi-input and multi-output systems. In existing studies, different control strategies are presented, including reduced static pressure control strategy (Tung S L and Deng Shiming 1997) and fan control method by total air volume (Dai Binwen Di Hongfa and Jiang Yi 1999). For the application of Display-Play-Data (DDC) control and development of VAV terminals such as pressure independent terminal, instabilities of air system have been basically settled. In order to provide better operation performance and consume lower energy, variable set-point control of supply air temperature is applied in VAV system. But such control strategy may enlarge

the influence of crosscoupling and demand higher system stability. Kasahara (2001) suggested 'voting method' to decide supply air temperature set-point, and the tuning of PID controller in VAV systems has been well studied by many researchers (House John M. 2004, Kasahara M. Yamazaki T 2001, L.H. Fu 2005).

Previous researchers have done a lot of work in studying failures caused by the time-delay of air and actuators in VAV system. But it can't solve the problems caused by other reasons, especially when cooling and heating are required at the same time. Therefore, the authors suggest distinguishing hunting types first and then taking different countermeasures to solve these hunting problems.

HUNTING PROBLEM ANALYSIS

Classification

Hunting problem is defined as a kind of system failure in troubleshooting flow (2006), the reasons of which can be sorted into three categories.

1. Improper-zoning or incorrect selected terminal, which attributes to poor design.
2. Improper initial adjustment of the control system, which attributes to the faultiness of adjusting method, i.e. bad tuning of PID controller.
3. Poor control strategy, which fails in providing stable control when heating and cooling is needed by different terminals simultaneously.

Existing research mostly focus on the second type, while this paper aims at solving hunting problem of the third type through a practical case study and computer simulation.

Real case analysis

Beijing Fortune Building is a slap-up office building which was built in 1980s. The construction area is 54490 m². There are 20 stories up ground and 2 stories underground. General stories are divided into two large sections and either section includes 3 zones as shown in Fig.1 (I.Z.A/B-interior zone in section A/B; W.P.Z.A-west perimeter zone in section A; N.P.Z.B-north perimeter zone in section B; SE.P.Z.A/B-southeast perimeter zone in section A/B).

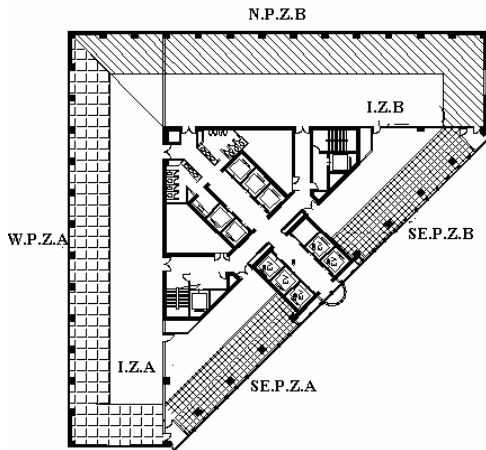

Figure 1 Air-conditioning system zoning

Pressure independent VAV system is designed and the basic control strategies are as follows:

1. Several terminals are linked to each VAV BOX, which collects the data of practical supply air volume, room temperature. And it calculates the required supply air volume based on the deviation between set and practical room temperature and supply air temperature. Central monitor collects each required supply air volume and calculates the total air volume. The data was transferred to fan controller. It adjusts transducer to meet the requirements of air volume. Control system calculates every 5 min.
2. Supply air temperature is increased or reduced according to the deviation between set and practical room temperature as well as all terminals' supply air volume by VAV Box. Every voting is transferred to the central monitor and the set supply air temperature is calculated by Kasahar's (2001) 'voting method'.
3. Air Handle Unit (AHU) controller modifies the opening of water valves to meet the requirement of supply air temperature.

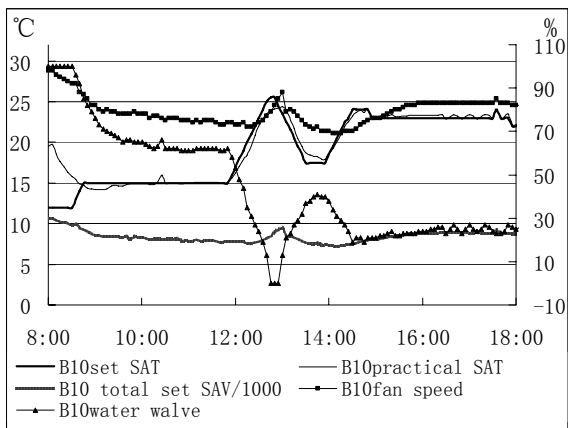

Figure 2 Curve of AHU parameters (B10, May 8th)

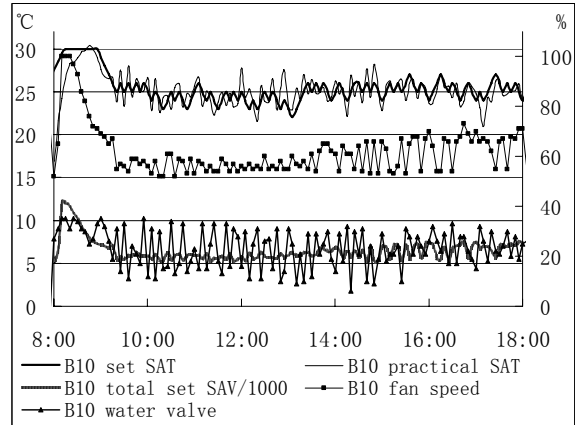

Figure 3 Curve of AHU parameters (B10, Jan 26th)

Although nearly most VAV systems perform well, hunting problem appears in VAV system of B10 (I.Z.B-interior zone in section B in Fig.1). There are 6 VAV BOXs in B10 which run well in most of the time except in winter (as seen in Fig. 2). The supply air temperature and total supply air volume change steadily and no hunting problems appears. Fig.3 is an example of hunting situation (the parameters of the AHU in B10 in Jan 26th). The supply air temperature varies between 22°C and 27°C, which may result in the abrasion of the water valve. The total supply air volume is shaking, which may cause the concussion of the fan transducer. Hunting problem can be found in supply air volume of most VAV boxes. Curve of Box 1 with hunting failure can be seen in Fig.4.

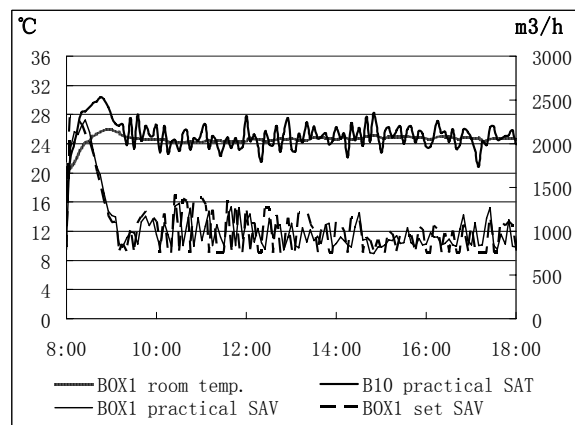

Figure 4 Curve of BOX1 parameters (B10, Jan 26th)

The hunting problem mainly happens when cooling and heating are required simultaneously for different terminals for some reasons. The most possible reason is load diminishment, which always occurs in exterior zone in transitional season or in the interior zone in winter. For example, B10 is an interior zone which is considered to have nearly constant cooling load because of indoor heat source and no external

façade. However, interior and exterior zones can hardly be separated in large-scale open office room in practical project, the load of interior may be influenced by exterior room and even outdoor climate. Meanwhile, indoor occupancies may change randomly which results in variation of indoor heat source. Furthermore, terminal's indoor temperature setpoint may be different with each other because of occupancy requirement. Therefore this interior zone gets a very low load in winter daytime. As shown in Fig.5, Box1 always needs cooling amount while other Boxes always need heating amount..

These kinds of hunting problem are not caused by failed design or poor system tuning. The former two reasons are inevitable results of the load characteristics of original construction structure and rooms' function. Different with the former reasons, the room temperature set-point can be modified artificially, which might be the sticking point to solve this problem.

IMPROVED CONTROL STRATEGY

In order to solve this problem, the authors developed a new method based on the original 'voting method', which changes specific VAV BOX's room temperature set-point when hunting is found. The steps are:

1. Make sure that hunting appears;
2. Record how many terminals' supply air temperature need to be changed and each terminal's demanding type (increase/decrease);
3. Judge and find out the minority terminals which have the opposite demanding to the others;
4. Adjust the room temperature set-point of these minority terminals with a certain regulatory degree (e.g. 1°C) to the direction of the practical temperature deviation from the former set-point;
5. Set a maximum adjusting degree. Stop adjusting the terminal set-point if it has been adjusted to the maximum degree, and start to adjust other terminals.

This method is to pick out the terminals that have different type of load requirement with the others. It utilizes central controller and DDC to adjust the set-point of room temperature. The intention is to relieve or cut down hunting, at the same time maintaining an approximately same control performance.

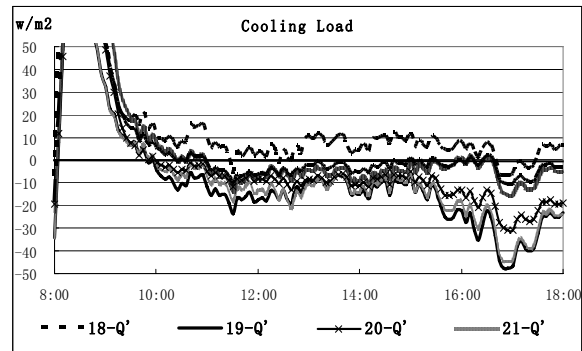

Figure 5 Curve of terminal old load (B10, Jan 26th)

Simulation Module

The simulation of VAV system is developed based on Matlab 6.5/Simulink. At first, the simulation results are compared with the measured data to validate the module. And then, a sub-module which solves the hunting problem is introduced to the main module to analyze the effect of the improved voting control strategy.

There are two main parts of the VAV system simulation module as shown in Fig 6. One is the terminal module and the other is the supply air temperature module. Each VAV BOX has a terminal module which is composed of 2 sub-modules (Fig. 7), supply air volume sub-module and room temperature sub-module.

The input parameters are the real load and the initial room temperature set-point of each VAV BOX every 5 minutes, The output parameters of each VAV BOX include supply air volume, practical room temperature, revised room temperature set-point and supply air temperature every 5 minutes.

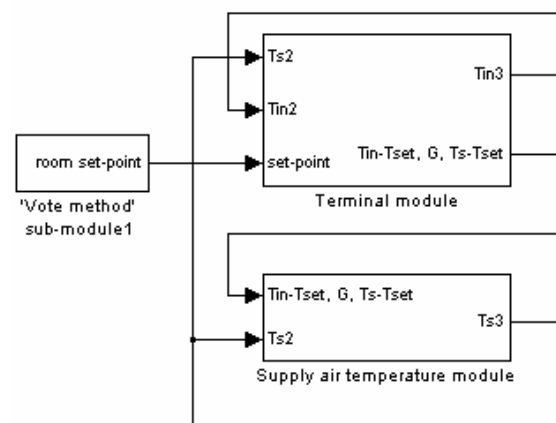

Figure 6 VAV system simulation module structure

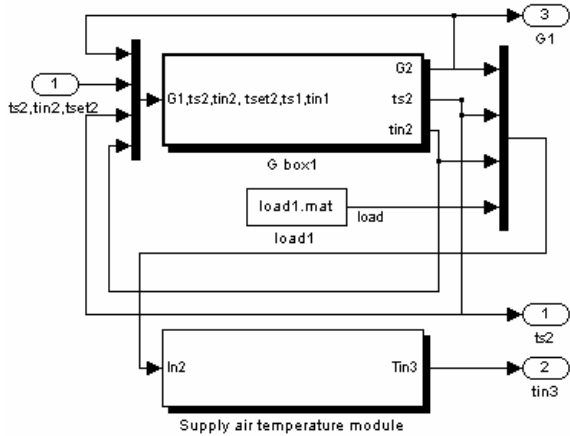

Figure 7 Terminal module structure

Module Validation

There are 6 VAV BOXs in zone B10 and the real load of each VAV BOX is calculated by the practical parameters including supply air temperature, room temperature and supply air volume every 5 minutes (shown in Fig.5). Table 1 shows the initial set room temperature of each VAV BOX.

As seen in Fig. 9, the control performance of each terminal is good except BOX1, whose average practical temperature is 1°C lower than the set-point 25°C. The simulation result (Fig. 9) is quite close to the practical control performance (Fig. 8).

Table 1 Practical initial set-point of room temperature

	BOX 1	BOX 2	BOX 3	BOX 4	BOX 5	BOX 6
Set-point (°C)	25	25	25	25	25	25

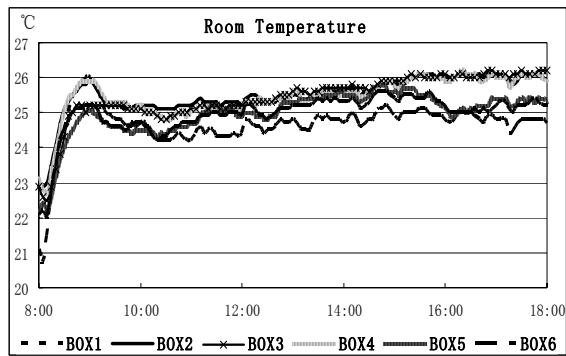

Figure 8 Practical results of room temperatures

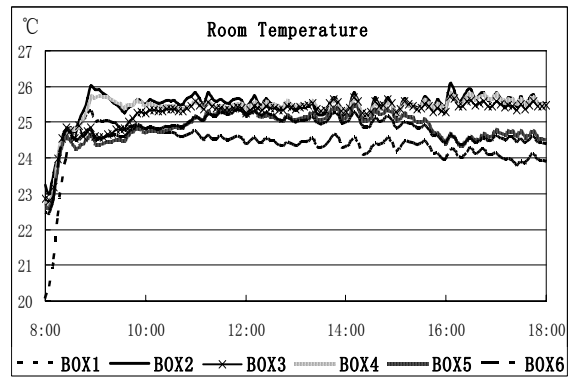

Figure 9 Simulation results of room temperatures

The supply air volume sub-module of Simulink applies PID method which also considers the change of supply air temperature. When using the same supply air temperature time series, the simulation results are quite consistent with the practical situation (Fig. 10).

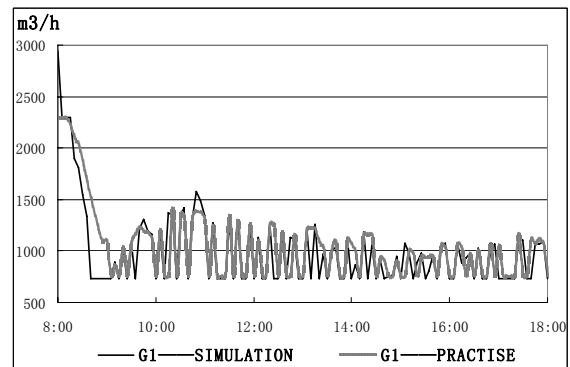

Figure 10 Air volume of practice and simulation result

The simulation result of supply air temperature is shown in Fig. 11 and hunting problem can be found. The temperature is vibrating between 23°C and 26°C. The simulation result is creditable.

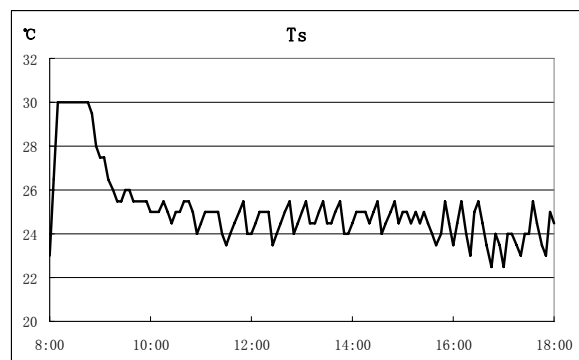

Figure 11 Simulation results of supply air temperatures

Application of improved voting control method

‘Voting method’ sub-module is programmed and added to modify the room set-point of VAV BOXs

and the regulatory degree is set as 1°C (the choosing of regulatory degree is related to the logical control of VAV system especially to the parameters in supply air temperature module).

The control performance of the improved strategy is shown in Fig. 12. In comparison with original control strategy, curve of room temperature (Fig. 12) shows a good performance of thermal environment control and supply air temperature (Fig. 13) become more stable and hunting failure is nearly avoided.

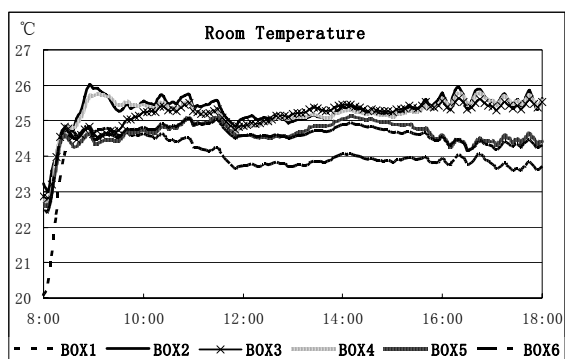

Figure 12 New simulation results of room temperatures

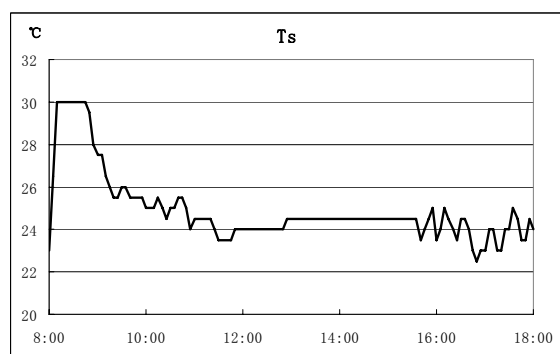

Figure 13 New simulation results of supply air temperatures

DISCUSSION AND RESULT ANALYSIS

The causes of the 3rd type of hunting problem come down to heating and cooling needed by different terminals simultaneously. During practical studies, when the 3rd type of hunting appears, although the system repeats adjusting the supply air temperature and air volume, the room temperature could not be controlled strictly to the desired condition (For example, room temperature of BOX1 can not reach room set-point in an established VAV system as shown in Fig. 9 and Fig. 12).

The 3rd type of hunting problem mainly happens in transitional season or when very low cooling/heating amount is required. Actually, under such circumstance, the room temperature doesn't need to be controlled strictly to a rigid temperature range. Therefore, the comfort temperature range could be properly enlarged. For example, after decreasing the

room set-point (equal to enlarging the temperature range), the practical room temperature changed from 23.5°C to 25 °C (winter) as shown in Fig.13. The indoor thermal environment is still acceptable.

To sum up, after adding the improved 'voting method' sub-module, the hunting phenomenon decreases significantly. The frequency of changing times of the supply air temperature decreases from 44 times to 5 times.

CONCLUSION

Through case study, the authors divide hunting problem into three categories and suggest different countermeasures. Previous research mostly discuss the hunting problem of type 2. This paper proposed 'voting method' control strategy to change room set-point and solve hunting problem of type 3. Matlab-Simulink is applied to set up module. The results are predicated with the measured input data and compared with experiment results. Finally the 'voting method' of room set-point is applied in module and the results validate the effect to reducing hunting at the same time maintaining the control performances..

By improving the control strategy as discussed in this research, the hunting problem of type 3 could be alleviated to some extent and therefore the VAV control performance could be optimized.

REFERENCES

- Chen, X.; Kamimura, K. Vote method of deciding supply air temperature setpoint for VAV air-conditioning system. ASHRAE Transactions, v 107 PART. 1, 2001, p 82-92
- Dai Binwen, Di Hongfa, Jiang Yi. Fan control method by total air volume in VAV systems. Journal of HVAC, 29(3):1-6,1999
- Fu Long Hai, Li Meng. Variable-Air-Volume Air-Conditioning System Based on PID-ANN Decoupling Control Technology. Journal of Southwest Jiaotong University, 2005, 1
- Han Zheng, Xia Chunhai, Zhu Yingxin, Xu Guohai. Application of OCM in Commissioning of VAV System. 2007,
- Hartman T. TRAV —a new HVAC concept [J] . Heating ,Piping & Air Conditioning, 1989 ,(7): 69 – 73
- House, John M.. PID and process gain. HPAC Heating, Piping, AirConditioning Engineering, v 76, n SUPPL., October, 2004, p 30-33+85
- Kasahara, M; Yamazaki, T.; Kuzuu, Y.; Hashimoto, Y.; Kamimura, K.; Matsuba, T.; Kurosu, S. Stability analysis and tuning of PID controller in

VAV systems. ASHRAE Transactions, v 107
PART. 1, 2001, p 285-296

Tung S L , Deng Shiming. Variable air volume air
conditioning system under reduced static
pressure control [J]. Building Services
Engineering Research & Technology ,1997 , 18
(2) :77 - 83