

## FROM RESEARCH TO MANUSCRIPT

# From Research to Manuscript

## A Guide to Scientific Writing

*by*

**MICHAEL JAY KATZ**

*Case Western Reserve University,  
Cleveland OH, U.S.A.*

 Springer

A C.I.P. Catalogue record for this book is available from the Library of Congress.

ISBN-10 1-4020-4045-8 (PB)  
ISBN-13 978-1-4020-4045-0 (PB)  
ISBN-10 1-4020-4071-7 ( e-book)  
ISBN-13 978-1-4020-4071-9 (e-book)

---

Published by Springer,  
P.O. Box 17, 3300 AA Dordrecht, The Netherlands.

*www.springer.com*

*Printed on acid-free paper*

All Rights Reserved

© 2006 Michael Jay Katz. The exclusive exploitation and distribution rights remain with Springer.

No part of this work may be reproduced, stored in a retrieval system, or transmitted in any form or by any means, electronic, mechanical, photocopying, microfilming, recording or otherwise, without written permission from the Publisher, with the exception of any material supplied specifically for the purpose of being entered and executed on a computer system, for exclusive use by the purchaser of the work.

Printed in the Netherlands.

# Contents

ACKNOWLEDGEMENTS .....	vii
INTRODUCTION.....	ix
SCIENTIFIC PAPERS USED AS EXAMPLES .....	xi
1. TOOLS AND TECHNIQUES .....	1
1. The Standards.....	1
1.1. A Stereotyped Format .....	1
1.2. Precise Language.....	1
1.3. A Single, Clear Direction .....	2
1.4. Reviewed and Made Available to Others.....	2
2. Words and Text .....	3
2.1. Write with Exactness and Clarity.....	3
2.2. How to Write Text.....	6
2.3. Advice to Speakers of Other Languages .....	24
3. Numbers .....	25
3.1. Tables .....	27
3.2. Statistics.....	30
4. Figures .....	41
4.1. Basic Guidelines .....	41
4.2. Figure Legends.....	43
4.3. Graphs .....	43
4.4. Aesthetics of Numerical Figures.....	48
5. Scientific Patterns.....	49
2. THE SCIENTIFIC PAPER .....	51
1. Research and Writing .....	51
1.1. Daily Lab Notebook.....	51
1.2. A Beginning Draft.....	52
2. Writing the Sections of a Scientific Paper.....	53
2.1. Materials and Methods .....	54

2.2. Appendix.....	66
2.3. Results.....	68
2.4. Discussion.....	85
2.5. Conclusion.....	101
2.6. Introduction.....	104
2.7. Title.....	113
2.8. Abstract.....	115
2.9. References.....	121
2.10. Footnotes.....	123
2.11. Acknowledgements.....	124
3. PREPARING TO PUBLISH.....	125
1. Gestation and Rewriting.....	125
1.1. Details of Style.....	125
1.2. Rewrite.....	126
1.3. A Friendly Critique.....	127
1.4. Read the Paper Backwards.....	127
1.5. Spelling.....	128
2. Final Manuscript Preparation.....	129
3. Responding to Editors and Referees.....	132
3.1. A Precritique Rewrite.....	132
3.2. The Comment-by-Comment Letter.....	132
3.3. Stay Calm.....	133
APPENDIXES.....	135
A. Words That Are Often Misused.....	135
B. Simplifying Wordy, Redundant, and Awkward Phrases.....	141
C. Standard Scientific Abbreviations.....	143
D. Typical Bibliographic Formats.....	147
E. Additional Reading.....	149
INDEX.....	151

## Acknowledgements

I thank journal editors Olaf Andersen, John Bennett, Lynn Enquist, David Fastovsky, Robert Genco, William Giannobile, Kathryn Harden, Theodore Harman, William Koros, James Olds, David Rosenbaum, Catharine Ross, and George Schatz for suggesting specific well-written scientific papers. Permissions to quote from their papers were granted by: Daniela Berg, David Fastovsky, Jacqueline Geraudie, David Rosenbaum, and Benjamin Widom. Permissions to reproduce the first page of their articles for the book cover were granted by: Daniela Berg and Jacqueline Geraudie.

Journal permissions for quotations:

- Augspurger *et al.* 2005. *J Nutrition* 135: 1712–1717 [copyright 2005, permission from the American Society for Nutritional Sciences].
- Bohm *et al.* 2005. *Leukemia Res* 29: 609–615 [copyright 2005, permission from Elsevier Ltd.].
- Borgens *et al.* 2004. *J Neurosci Res* 76: 141–154 [copyright 2004, permission from Wiley-Liss, Inc., a subsidiary of John Wiley & Sons, Inc.].
- Fastovsky and Sheehan. 2005. *GSA Today* 15: 4–10 [permission from the Geological Society of America].
- Gapski *et al.* 2004. *J Periodontol* 75: 441–452 [permission from the American Academy of Periodontology].
- Glaunsinger and Ganem. 2004. *J Exp Med* 200: 391–398 [copyright 2004, permission from The Rockefeller University Press].
- Milner *et al.* 1968. *Sci* 161: 184–186 [copyright 1968, permission from AAAS].
- Readinger and Mohny. 2005. *J Electronic Materials* 34: 375–381 [permission from the Minerals, Metals & Materials Society].
- Sugimori *et al.* 1994. *Biol Bull* 187: 300–303 [permission from The Biological Bulletin].
- Sundar and Widom. 1987. *J Phys Chem* 91: 4802–4809 [copyright 1987, permission from the American Chemical Society].
- Williams CM. 1961. *Biol Bull* 121: 572–585 [permission from The Biological Bulletin].

## Introduction

### Observations *Plus* Recipes

It is sometimes said that science is the orderly collection of facts about the natural world. Scientists, though, have been increasingly wary of using the word ‘fact.’ ‘Fact’ has the feeling of absoluteness and universality. “Children have 20 deciduous (baby) teeth” is an observation about the real world, but scientists would not call it a fact or even a complete scientific statement. Some children have fewer deciduous teeth, and some have more. Moreover, those children who *do* have 20 deciduous teeth use their full complement of deciduous teeth during only a brief part of their childhood. As babies and toddlers, they have fewer teeth. As older children, not all their deciduous teeth are still in place because the deciduous teeth are being replaced by permanent teeth. In addition, the statement “children have 20 deciduous teeth” does not tell us what we mean by “teeth.” Are “teeth” only those that can be seen with the unaided eye or do we also include the hidden, unerupted teeth?

An observation such as “children have 20 deciduous teeth” is not a fact, and it only becomes a scientific observation when it comes with definitions and qualifiers. The simplest and most thorough way to add the needed scientific depth to an observation is to describe how the observation was made. The observation “children have 20 deciduous teeth” can be made scientifically meaningful by describing the recipe that generated it, a recipe such as: “I looked in the mouths of 25 five-year-old boys and 25 five-year-old girls in the Garden Day Nursery School in Cleveland, OH, on Monday, May 24, 2005, and found that 23 of the boys and 25 of the girls had 20 visible teeth.”

The standard form for recording meaningful scientific observations—observations with their recipes—is the scientific paper.

### Writing a Scientific Paper

Science is the orderly collection of observations about the natural world made via well-defined procedures, and modern science is an archive of scientific papers. A

research project has not contributed to science until its results have been reported in a paper, the observations in which are accompanied by complete recipes.

As a contributing scientist, you must write scientific papers. Writing a good scientific paper takes time. On the other hand, the writing will seem endless if you begin with the title and slog straight through to the last reference. This approach is difficult, wearing, and inefficient. There is a much more effective way to write.

I suggest that you write your paper from the inside out. Begin with the all-important recipes, the Materials and Methods. Next collect your data and draft the Results. As your experiments end, formulate the outlines of a Discussion. Then write a working Conclusion. Now go back and write the historical context, the Introduction. Only after all else has been written and tidied up, will you have sufficient perspective to write the Title and the Abstract.

Throughout your writing, your tools and techniques will be the same. You should use precise words and, whenever possible, numbers. You should write direct sentences that follow a straight line from point A to point B. And, you should thoroughly complete every section of the stereotyped format of a standard scientific paper.

Writing a paper should be an active part of your research. If you wait until your studies are finished before you begin to write, you will miss a powerful tool. Research is iterative—you do, you assess, and you redo. Writing a paper is a way for you to continually make the assessments necessary for critical and perceptive research.

Your manuscript can be a blueprint for your experiments. The empty skeleton of a scientific paper poses a set of research questions. As you fill in the skeleton, you automatically carry out an orderly analysis of your data and observations. And, by continually setting new data into the draft of your paper, you can maintain perspective. You will filter out the shine of “newness,” as your results—even unusual results—are put into the context of your full research plan.

As a scientist, you must write, and as an experimentalist, writing while you work strengthens your research.



## Scientific Papers Used as Examples

In the text of this book, I rebuild a paper that I wrote in 1985, entitled “Intensifier For Bodian Staining of Tissue Sections and Cell Cultures.” I use this paper because it is brief, simple, and well-known to me.

Just as a picture is worth a thousand words, an actual example of a well-written scientific paragraph is worth a dozen descriptions of one. To illustrate the craft of scientific writing, I have included excerpts from far better scientific papers than my own. The excerpts are from articles across the range of scientific studies. These papers are lean, logical, and cleanly-written. They are examples of especially good science writing and have, for the most part, been recommended to me by the editors of the journals in which they appeared. In the text, I refer to the papers by author(s) and date. Here are the full bibliographic citations:

- Abercrombie M, Heaysman JEM. 1954. Observations on the social behaviour of cells. II. “Monolayering” of fibroblasts. *Exp Cell Res* 6: 293–306.
- Augsburger NR, Scherer CS, Garrow TA, Baker DH. 2005. Dietary s-methylmethionine, a component of foods, has choline-sparing activity in chickens. *J Nutrition* 135: 1712–1717
- Berg D, Siefker C, Becker G. 2001. Echogenicity of the substantia nigra in Parkinson’s disease and its relation to clinical findings. *J Neurol* 248: 684–689.
- Bohm A, Piribauer M, Wimazal F, Geissler W, Gisslinger H, Knobl P, Jager U, Fonatsch C, Kyrle PA, Valent P, Lechner K, Sperr WR. 2005. High dose intermittent ARA-C (HiDAC) for consolidation of patients with de novo AML: a single center experience. *Leukemia Res* 29: 609–615.
- Borgens RB, Bohnert D, Duerstock B, Spomar D, Lee RC. 2004. Tri-block copolymer produces recovery from spinal cord injury. *J Neurosci Res* 76: 141–154.
- Fastovsky DE, Sheehan P. 2005. The extinction of the dinosaurs in North America. *GSA Today* 15: 4–10.
- Gapski R, Barr JL, Sarment DP, Layher MG, Socransky SS, Giannobile WV. 2004. Effect of systemic matrix metalloproteinase inhibition on periodontal wound repair: a proof of concept trial. *J Periodontol* 75: 441–452.

- Glaunsinger B, Ganem D. 2004. Highly selective escape from KSHV-mediated host mRNA shutoff and its implications for viral pathogenesis. *J Exp Med* 200: 391–398.
- Haseler LJ, Arcinue E, Danielsen, ER, Bluml S, Ross D. 1997. Evidence From Proton Magnetic Resonance Spectroscopy for a Metabolic Cascade of Neuronal Damage in Shaken Baby Syndrome. *Pediatrics* 99: 4–14.
- Jacobson C-O. 1959. The localization of the presumptive cerebral regions in the neural plate of the axolotl larva. *J Embryol Exp Morph* 7: 1–21.
- Milner B, Taylor L, Sperry RW. 1968. Lateralized suppression of dichotically presented digits after commissural section in man. *Sci* 161: 184–186.
- Paul DR, McSpadden SK. 1976. Diffusional release of a solute from a polymer matrix. *J Membrane Sci* 1: 33–48.
- Perez JF, Sanderson MJ. 2005. The frequency of calcium oscillations induced by 5-HT, ACH, and KCl determine the contraction of smooth muscle cells of intrapulmonary bronchioles. *J Gen Physiol* 125: 535–553.
- Readinger ED, Mohney SE. 2005. Environmental sensitivity of Au diodes on n-AlGaIn. *J Electronic Mater* 34: 375–381.
- Richards TW, Lambert ME. 1914. The atomic weight of lead of radioactive origin. *J Am Chem Soc* 36: 1329–1344.
- Rosenbaum, DA. 2005. The Cinderella of psychology. The neglect of motor control in the science of mental life and behavior. *Am Psychologist* 60: 308–317.
- Rutherford E. 1919. Collisions of alpha particles with light atoms. IV. An anomalous effect in nitrogen. *Lond Edinb Dubl Phil Mag J Sci* 37: 581.
- Singer M, Weckesser EC, Geraudie J, Maier CE, Singer J. 1987. Open finger tip healing and replacement after distal amputation in Rhesus monkey with comparison to limb regeneration in lower vertebrates. *Anat Embryol* 177: 29–36.
- Speidel CC. 1932. Studies of living nerves. I. The movements of individual sheath cells and nerve sprouts correlated with the process of myelin-sheath formation in amphibian larvae. *J Exp Zool* 61: 279–317.
- Sugimori M, Lang EJ, Silver RB, Llinas R. 1994. High-resolution measurement of the time course of calcium-concentration microdomains at squid presynaptic terminals. *Biol Bull* 187: 300–303.
- Sundar G, Widom B. 1987. Interfacial tensions on approach to a tricritical point. *J Phys Chem* 91: 4802–4809 .
- Williams CM. 1961. The juvenile hormone. II. Its role in the endocrine control of molting, pupation, and adult development in the *Cecropia* silkworm. *Biol Bull* 121: 572–585.

## Chapter 1

# TOOLS AND TECHNIQUES

## 1. THE STANDARDS

### 1.1. A Stereotyped Format

Scientific articles are the repositories of scientific observations, with the recipes by which those observations can be repeated.

Scientific papers have a stereotyped format. Usually, it is:

- Abstract
- Introduction
- Materials and Methods
- Results
- Discussion
- Conclusion
- References

The predictable form and standard order ensure that a reader knows what to expect. The exact section headings sometimes vary, but most scientific papers look pretty much the same from the outside. There are no novel constructions or inventive twists and turns of the narrative. Instead, the framework is always the same so that the inner content can be studied without distraction.

### 1.2. Precise Language

Within this stereotyped format, the language of a scientific paper aims to be clean, clear, and unemotional.

Much of the color of our everyday language derives from ill-defined, emotionally charged, ear-tickling images conjured up by sensuous words such as “slovenly,” “sibilant,” and “sneaky.” Science avoids colorful words. The essential characteristic of scientific writing is clarity. Slippery words and vague phrases are confusing, and there is no place for ambiguity, arcane language, or froth. In science, descriptions must be

precise, recipes must be complete, data must be exact, logic must be transparent, and conclusions must be cleanly stated.

### **1.3. A Single, Clear Direction**

Beyond a stereotyped format and transparent language, a scientific paper also needs clarity of direction. Your entire paper should point inexorably toward its Conclusion.



As you write, point the way for your reader, and remove tangents and asides. Keep a single theme at the fore. If your Conclusion is about temperature, temperature should be ever-present throughout your paper. “Temperature” should be in the Title. The Introduction should tell how your predecessors wrote about temperature. The Materials and Methods section should detail the instruments that you used and the operations that you performed involving temperature. The Results section should include data about temperature, and the Discussion section should connect this data to generally accepted understandings about temperature.

### **1.4. Reviewed and Made Available to Others**

A scientific paper should be accessible to others. Scientific journals are the traditional mechanisms for reviewing, disseminating, and preserving scientific papers, so submit your paper to a peer-reviewed journal. Having your paper reviewed by experts ensures that it can be understood and used by a broad scientific community. And, having your paper preserved in a public forum ensures that the scientific community will have the opportunity to use it.

## 2. WORDS AND TEXT

### 2.1. Write with Exactness and Clarity

#### 2.1.1. Write a Straightforward Message

In science, your goal is to write a paper that is easy to understand. The art of scientific writing is in highlighting the details of the observations that you have made. In a short story, the reader might marvel at the “sensual prose, with hints of the mysteries of space and time.” In a scientific paper, however, your prose style should disappear, and instead the reader should marvel at the realistic picture of some event you observed, edged with crystalline detail.

Scientific papers have a stereotyped format so that there are no distractions from their contents. Likewise, scientific prose should be formulaic and plain. Here, the medium is not the message, the *message* is the message. When you write, make your message precise, and keep the medium unobtrusive. It can be an effort to always recognize them, but train yourself to catch and remove vagaries, emotion, indirectness, and redundancy. For examples of the simplification of wordy, redundant, and awkward phrases, see Appendix B below.

It helps to remember that your goal is to speak plainly, to write clean straightforward sentences without hedging or hinting. Say what you mean directly:

“It may therefore not be unexpected that . . .”

should be

“These results suggest . . .”

“An effort was made to . . .”

should be

“We tried to . . .”

“The sorbitol probably acts to increase . . .”

should be

“The sorbitol probably increases . . .”

“This gene is of significant interest to understanding commonalities in the evolutionary history of the microorganisms A and B”

is clearer, simpler, and more informative when you tell exactly what you have in mind, such as

“A single mutation in this gene of microorganism A has brought about its new use in microorganism B.”

“It is our considered opinion that other authorities may have misstated the relative import of such particulate concatenations in the soluble phase of the paradigm”

should be written with specifics, such as

“In their 1994 paper, Drs. Williams and Wilkins say the drug’s failures are due entirely to the clumping of suspended drug particles. In contrast, we propose that the viscosity of the solvent causes 40-50% of the failures.”

## 2.1.2. Write with Precision

A scientific paper must be readable, but it is not literary prose. In science, a smooth flowing style and balanced wording are appreciated, but the essence of the scientific style is clarity and precision. Each sentence must present an idea written in an unequivocal vocabulary.

### 2.1.2.1. Numbers

Numbers are precise and objective, and they can be used to describe most things in the real world.

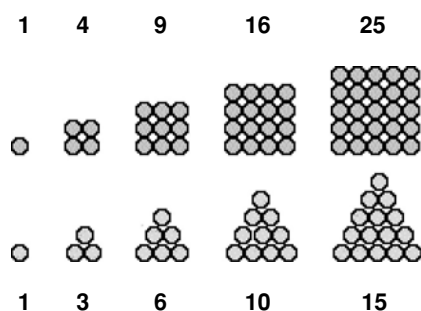

For these reasons, quantifiable words are the natural words for science. Try to define critical adjectives as numbers: *tall* should be *greater than 2 m* likewise *heavy* should be *greater than 10 kg*. Tell us whether *brief* means *less than a second*– or *less than a millisecond*. Even the inherently subjective adjective *painful* should be set as a number on a scale quantifying *how painful*

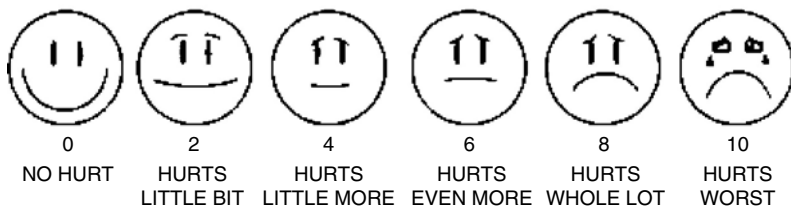
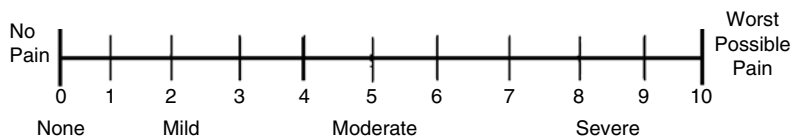

as is now done in most hospitals.

### 2.1.2.2. Objective Words

Of course, you cannot write with only numbers. Try, however, always to use precise and objective language.

Scientific language is well-defined language. Whether any particular sentence is precise and objective, depends on your ability to define all its components. For example, “The needle vibrated continuously” is appropriate in a scientific paper if the reader is led to understand exactly which needle, what manner of vibration, and over what time period it vibrated continuously. The most general rule is:

Define your words

Beyond this rule, there are some techniques and habits that will keep you on the road to good scientific text. For instance, it is always good to avoid intrinsically vague and subjective terms. Don't use:

- expressions with no clear limits  
*a lot, fairly, long term, quite, really, short term, slightly, somewhat, sort of, very*
- words of personal judgment  
*assuredly, beautiful, certainly, disappointing, disturbing, exquisite, fortuitous, hopefully, inconvenient, intriguing, luckily, miraculously, nice, obviously, of course, regrettable, remarkable, sadly, surely, unfortunately*
- words that are only fillers  
*alright, basically, in a sense, indeed, in effect, in fact, in terms of, it goes without saying, one of the things, with regard to*
- casual colorful catch-words and phrases  
*agree to disagree, bottom line, brute force, cutting edge, easier said than done, fell through the cracks, few and far between, food for thought, leaps and bounds, no nonsense, okay, quibble, seat of the pants, sketchy, snafu, tad, tidbit, tip of the iceberg*

### 2.1.3. Scientific Use of Tenses

One other convention that helps the scientific reader is the proper use of verb tense in your scientific paper.

#### 2.1.3.1. Present Tense

Use the present tense for the general case and for statements of what is already known. Write general knowledge statements, widely accepted statements, and statements for which you could cite textbook references in the present tense. For example:

“Most Guatemalan tarantulas are black and red or orange.”

“Hexoses formed by digestion in the intestinal tract are absorbed and reach the various tissues through the blood circulation.”

“The term ‘nuclide’ indicates a species of atom having specified numbers of protons and neutrons in its nucleus.”

“On a protein-rich diet, the amount of methylhistidine in the urine increases.”

### 2.1.3.2. Past Tense

On the other hand, use the past tense when referring to specific events that have already happened. The past tense is historical. The particular observations you made during a research study are bits of history, so use the past tense when you report experimental results. For example:

“In photographs of Guatemalan tarantulas, we found a range of 6–9 dorsal stripes.”

“During his war-time expedition to Guatemala, Rawski (1943) reported finding tarantulas with 9 stripes.”

“Eighteen percent of the patients in our study developed a mild rash.”

“The diodes were compared at regular time points during the next 75 h.”

## 2.2. How to Write Text

How do you write readable scientific paragraphs, paragraphs that are logical, spare, to-the-point, and complete? Well-organized text will not come easily if you work line by line, trying to thoroughly polish one sentence before moving to the next. Instead, it is better to work through whole sections of the paper each time you sit down to write.

In one work session, make lists of ideas, notes, and facts. In another session, transform the lists into sentences. Later, you can assemble paragraphs. In the end, you will polish the writing into a lean and straightforward narrative. You can dive into this stage-by-stage writing fearlessly, without knowing the final shape of the text, because you will discover the shape as the polished paragraphs emerge.

Creating a scientific manuscript is a process of writing out ideas, organizing them, disassembling the organization, rewriting, and then reassembling. To demonstrate this writing technique, I will describe how I wrote the first paragraph of my paper *Intensifier For Bodian Staining of Tissue Sections and Cell Cultures* (Katz MJ, Watson LF, 1985, *Stain Technol* **60**: 81–87). This paper reports a chemical intensification technique for a commonly used silver stain. The intensifier improves the staining of embryonic axons<sup>1</sup> and axons in tissue culture. I will use parts of this paper as simple examples throughout the book.

In the following ten sections, I am going to break the process of technical (nonliterary) writing into small bits. I am sure that you already combine many of these steps unthinkingly as you write. Things that are done “spontaneously” without thinking, however, can be improved more easily when they are made visible. So take a moment to look at the process of scientific writing in its most elementary steps.

### 2.2.1. The Skeletal Outline

As a general rule, you should begin writing your paper one section at a time. Each section of a scientific paper has a stereotyped internal structure, a skeletal outline. These

<sup>1</sup> An axon is the long, thread-like extension of a nerve cell. Axons carry electrical impulses from one cell to the next. Each axon is microscopically thin. When hundreds or thousands of axons are bundled together, they are called a “nerve.”



skeletons are described in Chapter 2. When writing the text of a section, start with an empty outline of its skeleton.

For example, the Introduction section of a scientific paper begins by summarizing a general and well-accepted idea. From this known information, the Introduction leads the reader to the particular unknown area that the paper plans to explore.

The skeleton of the Introduction section begins with the Background, which has two subsections:

A. Currently Accepted General Statement

---



---

B. Available Supporting Data

---



---

The Introduction is essentially historical, so the Currently Accepted General Statement subsection often starts with a statement about the past. My paper was about staining axons. I decided to divide the initial historical subsection into two topics, *general* and *specific*, and I wrote the following beginning outline:

A. Currently Accepted General Statement

1. General History of Axon Stains

---



---

2. Specific History of Bodian Stain

---



---

### 2.2.2. File in Ideas

Now fill the empty spaces in your outline. List all the related ideas that come to mind. Don't worry about completeness or logic, and don't write sentences.

A. Currently Accepted General Statement  
1. General History of Axon Stains

---



---

2. Currently Accepted General Statement

---



---

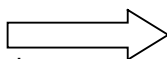

A. Currently Accepted General Statement  
1. General History of Axon Stains

- reproducible
- state of the art is molecule-specific
- signal amplification
- individual cell stains a big leap
- began with silver stains of Golgi and Cajal

2. Currently Accepted General Statement

- General History of Axon Stains
- reproducible
- state of the art is molecule
- organelle highlighting
- signal
- organelle highlighting
- individual cell stains a big leap
- began with silver

For the topic entitled General History of Axon Stains, I tried to think of words and phrases about the classic work on axon staining. My initial list was:

## A. Currently Accepted General Statement

### 1. General History of Axon Stains

- reproducible
- state of the art is molecule-specific
- organelle highlighting
- signal amplification
- individual cell stains a big leap
- began with silver stains of Golgi and Cajal

Continue brainstorming and jotting down notes for the entire outline of the section you are writing. Fill each empty subsection and topic with ideas and facts that come into your mind. Don't stop until each topic is followed by at least three words or phrases.

### 2.2.3. Collect Information from Outside Resources

At this point, go to your references—your books, articles, and notes. If you are working on a part of the paper that is built largely from outside information, such as the Introduction or the Discussion, you will probably use books and articles. If you are working on a section built largely from your experiments, such as the Materials and Methods or the Results, you will be using your lab notebook or your computerized research diary.

Search each reference for relevant information and add these facts (with a note about their sources) under the appropriate headings of your outline.

#### A. Currently Accepted General Statement

##### 1. General History of Axon Stains

- reproducible
- state of the art is molecule-specific
- signal amplification
- individual cell stains a big leap
- began with silver stains of Golgi and Cajal

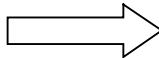

#### A. Currently Accepted General Statement

##### 1. General History of Axon Stains

- reproducible
  - state of the art is molecule-specific
  - signal amplification
  - individual cell stains a big leap
  - began with silver stains of Golgi and Cajal
- Ref A: - cresyl violet for neuron chromatin  
- neurons have strong affinity for weak silver solutions  
- Santiago Ramon y Cajal, 1890-1911 (Spain), summarized in Degeneration and Regeneration of the Nervous System  
- Stephen W Ranson, 1914 (USA)
- Ref B: - David Bodian 1936 used silver protein and metallic copper, produced clean stains of nerve cells, nuclei, axons, dendrites
- Ref C: - Camillo Golgi, Italian, late 19th century, pretreatment with potassium dichromate, followed by silver nitrate, stains fraction of neurons and neuroglia and blood vessels  
- Golgi method gives 3-D view, good for cell architecture  
- Silver stains = best views of individual cells until electron microscopy
- Ref D: - Golgi, 1880, first used photographic processing techniques  
Daguerre, 1839, to stain neural tissue

After doing this, my outline looked like:

## A. Currently Accepted General Statement

### 1. General History of Axon Stains

- reproducible
- state of the art is molecule-specific
- organelle highlighting
- signal amplification
- individual cell stains a big leap
- began with silver stains of Golgi and Cajal

- Ref A: – cresyl violet for neuron chromatin
- neurons have strong affinity for weak silver solutions
  - Santiago Ramon y Cajal, 1890–1911 (Spain), summarized in *Degeneration and Regeneration of the Nervous System* 1928
  - Stephen W Ranson, 1914 (USA)
- Ref B: – David Bodian 1936 used silver protein and metallic copper, produced clean stains of nerve cells, nuclei, axons, dendrites
- Ref C: – Camillo Golgi, Italian, late 19th century, pretreatment with potassium dichromate, followed by silver nitrate, stains only fraction of neurons and neuroglia and blood vessels
- Golgi method gives 3-D view, good for cell architecture
  - Silver stains = best views of individual cells until electron microscopy
- Ref D: – Golgi, 1880, first used photographic processing techniques of Daguerre, 1839, to stain neural tissue

#### 2.2.4. Form Rough Sentences

In this step, you take the words or phrases in your lists and replace them with full sentences, adding any information that is necessary to make the sentence complete.

To write a complete and understandable sentence often requires some careful thinking, and you will undoubtedly need to consult your references again.

Continue writing detailed sentences for the entire outline of the section that you are working on.

For my paper, I wrote:

##### A. Currently Accepted General Statement

###### 1. General History of Axon Stains

- Useful cell stains must give reproducible results.
- A good stain will be specific for components of the feature of interest, not the entire feature itself. For cells, a good stain highlights specific parts of the cell, the membranes or the various organelles. For membranes or organelles, a good stain highlights specific component molecules.
- A good stain of tiny items gives a signal that is strong or that can be easily amplified.
- For neuroanatomy, a big leap in understanding the architecture of the nervous system was the ability to stain an entire cell with all of its fine processes.
- The study of individually stained nerve cells began at the end of the nineteenth century with the Italian histologist Camillo Golgi and the Spanish histologist and father of neurohistology Santiago Ramon y Cajal.
- Cresyl violet proved a good stain for neuron cell bodies, highlighting the cell's chromatin.
- Neurons have a strong affinity for the silver in weak salt solutions.
- Between 1890 and 1911, Cajal meticulously documented the cellular architecture of the nervous system using silver stains. Much of his work is

summarized in the English tome *Degeneration and Regeneration of the Nervous System*, published in 1928.

- In the United States, Stephen W. Ranson began a series of silver studies on neural histology in 1914.
- In the United States, in 1936, David Bodian introduced a simple and reliable silver stain for axons using solutions of silver protein with metallic copper. His stain produced clean staining of the nerve cell, its axon and dendrites.
- The use of silver stains for neurons was introduced in the late nineteenth century by the Italian histologist, Camillo Golgi. His technique pre-treated the fixed tissues with potassium dichromate and followed with a solution of silver nitrate. The Golgi technique was idiosyncratic, staining only a fraction of the neurons, neuroglia, and neural blood vessels. However, a stained cell usually revealed the full three-dimensional cell architecture.
- Until the invention of electron microscopy, silver stains gave the best views of the three-dimensional structure of individual nerve cells.
- Golgi introduced his technique in 1880 and based it on Daguerre's 1839 procedures for processing silver-based photographs.

### 2.2.5. Arrange the Sentences into Themes

In the end, each of your finished paragraphs should be about a single idea. The first step toward building such paragraphs is to collect sentences that concern a common subject or theme. Collect related sentences and give each set a temporary label (Temporary Theme-Label, **TTL**).

#### A. Currently Accepted General Statement 1. General History of Axon Stains

- Useful cell stains must give reproducible results.  
- A good stain will be specific for components of the feature of interest, not the entire feature itself. For cells, a good stain highlights specific parts of the cell, the membranes or the various organelles. For membranes or organelles, a good stain highlights specific component molecules.  
- A good stain of tiny items gives a signal that is strong or that can be easily amplified.  
- For neuroanatomy, a big leap in understanding the architecture of the nervous system was the ability to stain an entire cell with all of its fine processes.  
- The study of individually stained nerve cells began at the end of the nineteenth century with the Italian histologist Camillo Golgi and the Spanish histologist and father of neurohistology Santiago Ramon y Cajal.  
- Cresyl violet proved a good stain for neuron cell bodies, highlighting the cell's chromatin.  
- Neurons have a strong affinity for the silver in weak salt solutions.  
- Between 1890 and 1911, Cajal meticulously documented the cellular architecture of the nervous system using silver stains. Much of his work is summarized in the English tome *Degeneration and Regeneration of the Nervous System*, first published in 1928.

#### A. Currently Accepted General Statement. 1. General History of Axon Stains

**Good Cell Stains In General** ← **TTL**

- Useful cell stains must give reproducible results.  
- A good stain will be specific for components of the feature of interest, not the entire feature itself.  
- For cells, a good stain highlights specific parts of the cell, the membranes or the various organelles.  
- For membranes or organelles, a good stain highlights specific component molecules.  
- A good stain of tiny items gives a signal that is strong or that can be easily amplified.

**Neuron Stains** ← **TTL**

- Cresyl violet proved a good stain for neuron cell bodies, highlighting the cell's chromatin.  
- Neurons have a strong affinity for the silver in weak silver salt solutions.  
- For neuroanatomy, a big leap in understanding the architecture of the nervous system was the ability to stain an entire cell with all its fine processes.  
- Until the invention of electron microscopy, silver stains gave the best views of the three-dimensional structure of individual nerve cells.

In my rough draft, I divided my list of sentences into three themes:

A. Currently Accepted General Statement

1. General History of Axon Stains

*Good Cell Stains In General*

«TTL

- Useful cell stains must give reproducible results.
- A good stain will be specific for components of the feature of interest, not the entire feature itself.
- For cells, a good stain highlights specific parts of the cell, the membranes or the various organelles.
- For membranes or organelles, a good stain highlights specific component molecules.
- A good stain of tiny items gives a signal that is strong or that can be easily amplified.

*Neuron Stains*

«TTL

- Cresyl violet proved a good stain for neuron cell bodies, highlighting the cell's chromatin.
- Neurons have a strong affinity for the silver in weak silver salt solutions.
- For neuroanatomy, a big leap in understanding the architecture of the nervous system was the ability to stain an entire cell with all its fine processes.
- Until the invention of electron microscopy, silver stains gave the best views of the three-dimensional structure of individual nerve cells.

*The History of Silver Stains*

«TTL

- The use of silver stains for neurons was introduced in the late nineteenth century by the Italian histologist Camillo Golgi.
- His technique pre-treated the fixed tissues with potassium dichromate and followed with a solution of silver nitrate.
- The Golgi technique was idiosyncratic, staining only a fraction of the neurons, neuroglia, and neural blood vessels; however, a stained cell usually revealed its full three-dimensional cell architecture.
- The study of individually stained nerve cells began at the end of the nineteenth century with the Italian histologist Camillo Golgi and the Spanish histologist and father of neurohistology Santiago Ramon y Cajal.
- Golgi introduced his technique in 1880 and based it on Daguerre's 1839 procedures for processing silver-based photographs.
- Between 1890 and 1911, Santiago Ramon y Cajal meticulously documented the cellular architecture of the nervous system using silver stains.
- Much of his work is summarized in the English tome *Degeneration and Regeneration of the Nervous System*, first published in 1928.
- In the United States, Stephen W. Ranson began a series of silver studies on neural histology in 1914.

- In the United States, in 1936, David Bodian introduced a simple and reliable silver stain for axons using solutions of silver protein with metallic copper.
- His stain produced clean staining of the nerve cell, its axon and dendrites.

### 2.2.6. Make the Lists into Rough Paragraphs

Now take the themes, one-by-one, and turn them into rough paragraphs.

A scientific paragraph usually starts with a summary sentence, and the succeeding sentences explain and expand the idea summarized in the first sentence. Begin your paragraph-building by discarding the Temporary Theme-Labels (TTL) that you wrote. Reread each group of sentences and create a better, more exact summary statement. Write this as the first sentence—the Lead Sentence (LS)—of the paragraph. Follow the lead sentence with the remaining sentences in an order that feels logical. Do this for the whole section.

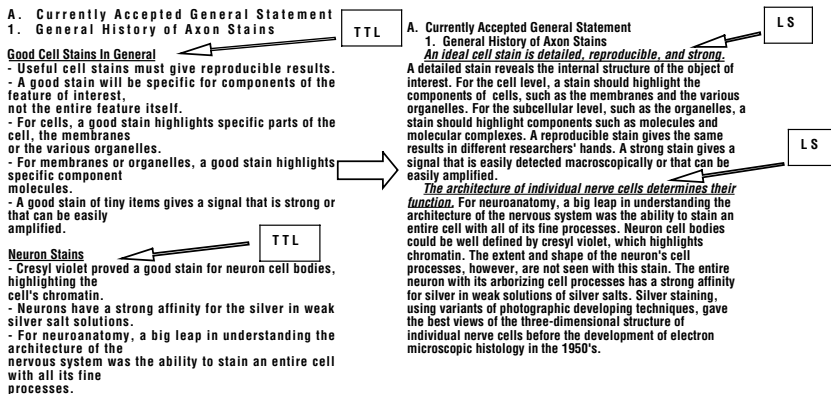

For the Introduction of my paper, I turned my first three groups of sentences into these three paragraphs:

#### A. Currently Accepted General Statement

##### 1. General History of Axon Stains

*An ideal cell stain is detailed, reproducible, and strong.* <<LS

A detailed stain reveals the internal structure of the object of interest. For the cell level, a stain should highlight the components of cells, such as the membranes and the various organelles. For the subcellular level, such as the organelles, a stain should highlight components such as molecules and molecular complexes. A reproducible stain gives the same results in different researchers' hands. A strong stain gives a signal that is easily detected macroscopically or that can be easily amplified.

*The architecture of individual nerve cells determines their function.* <<LS

For neuroanatomy, a big leap in understanding the architecture of the nervous system was the ability to stain an entire cell with all of its fine processes. Neuron cell bodies could be well defined by cresyl violet, which highlights chromatin. The

extent and shape of the neuron's cell processes, however, are not seen with this stain. The entire neuron with its arborizing cell processes has a strong affinity for silver in weak solutions of silver salts. Silver staining, using variants of photographic developing techniques, gave the best views of the three-dimensional structure of individual nerve cells before the development of electron microscopic histology in the 1950's.

*The use of silver stains for neurons was introduced in the late nineteenth century by the Italian histologist Camillo Golgi.* <<LS

Golgi introduced his technique in 1880 and based it on Louis Daguerre's 1839 procedures for processing silver-based photographs. Golgi's specific technique pre-treated the fixed tissues with potassium dichromate and followed with a solution of silver nitrate. The Golgi technique was idiosyncratic, staining only a fraction of the neurons, neuroglia, and neural blood vessels. However, a stained cell usually revealed the three-dimensional cell architecture. Beginning in 1890, the Spanish histologist Santiago Ramon y Cajal used silver stains to meticulously document the cellular architecture of the nervous system. Much of his work is summarized in the English tome *Degeneration and Regeneration of the Nervous System*, published in 1928. In the United States, Stephen W. Ranson began a series of silver studies on neural histology in 1914. In the United States, in 1936, David Bodian introduced a simple and reliable silver stain for axons using solutions of silver protein with metallic copper. His stain produced clean staining of the nerve cell and its axon and dendrites.

### **2.2.7. Put Things Aside . . . Clear Your Mind . . .**

It's time to take a break from writing.

As you wrestle, trying to organize partial ideas, the elements of your paper take on emotional tinges that come from your struggles. Gaps and problematic passages in your draft get blacker and bleaker and feel like irritants. New insights, clean connections, ingenious ideas, and perfect bits of fact take on a golden shine and feel disproportionately important.

Time is a great balancer. With distance, the temporary emotional tones in your work fade. Therefore, go away, turn your mind elsewhere, and let time refocus your vision.

### **2.2.8. Put Together One Paragraph for Each Topic**

When you pick up your draft again, work through the entire outline, topic by topic.

Each topic now contains a set of rough paragraphs. For each topic, decide which paragraph most directly addresses the main issue. Put this paragraph first under the topic's title.

Among your goals are directness and brevity. If any of the paragraphs deal with issues peripheral to the main point of the paper, toss them out.

Finally, consolidate the remaining paragraphs for each topic. If possible, merge them into the first paragraph. Try to forge only one or two paragraphs for each topic, even if, at this stage, those paragraphs are long, cumbersome, or difficult to read.

In my example, I had three rough paragraphs for the first topic, General History of Axon Stains. This topic was to be the very beginning of my Introduction, describing the early work on the silver staining of cells. Only one of my three rough paragraphs was historical, so I chose this to be the main paragraph. I then took key sentences from the other two rough paragraphs and merged them with the main paragraph. Finally, I tossed out the left-over sentences. The resulting paragraph was:

#### A. Currently Accepted General Statement

##### 1. General History of Axon Stains

The use of silver stains for neurons was introduced in the late nineteenth century by the Italian histologist Camillo Golgi. Golgi introduced his technique in 1880 and based it on Daguerre's 1839 procedures for processing silver-based photographs. Golgi's specific technique pre-treated the fixed tissues with potassium dichromate and followed with a solution of silver nitrate. He found that the entire neuron with its arborizing cell processes has a strong affinity for silver in weak solutions of silver salts. The Golgi technique was idiosyncratic, staining only a fraction of the neurons, neuroglia, and neural blood vessels. However, a stained cell usually revealed the three-dimensional cell architecture. Beginning in 1890, Santiago Ramon y Cajal used silver stains to meticulously document the cellular architecture of the nervous system. The architecture of individual nerve cells—specifically, the extent and shape of the neuron's cell processes—determines their function. Much of his work is summarized in the English tome *Degeneration and Regeneration of the Nervous System*, published in 1928. In the United States, Stephen W. Ranson began a series of studies on neural histology in 1914. In the United States in 1936, David Bodian introduced a simple and reliable silver stain for axons using solutions of silver protein with metallic copper. His stain produced clean staining of the nerve cell nuclei, axons, and dendrites. Silver staining using variants of photographic developing techniques gave the best views of the three-dimensional structure of individual nerve cells before the development of electron microscopic histology in the 1950's.

At the moment, your topic paragraphs will be wordy and awkward, but they will be just right for this stage in the writing process. Continue forming these foundation paragraphs for your entire outline.

## 2.2.9. Shaping a Working Draft

### 2.2.9.1. Lists of Simple Sentences

To clean and tighten the large, rough paragraphs, you must build them afresh. It's time to go back to lists.



Take each paragraph and list its sentences in order. If a sentence is complex, break it into two or three consecutive simple sentences.

#### A. Currently Accepted General Statement

##### 1. General History of Axon Stains

The cell level, a stain should highlight the components of cells, such as the membranes and the various organelles. For the subcellular level, such as the organelles, a stain should highlight components such as molecules and molecular complexes. The architecture of individual nerve cells determines their function. For neuroanatomy, a big leap in understanding the architecture of the nervous system was the ability to stain an entire cell with all of its fine processes. Neuron cell bodies could be well defined by cresyl violet, which highlights chromatin. The extent and shape of the neuron's cell processes, however, are not seen with this stain. The entire neuron with its arborizing cell processes has a strong affinity for silver in weak solutions of silver salts. Silver staining, using variants of photographic developing techniques, gave the best views of the three-dimensional structure of individual nerve cells before the development of electron microscopic histology in the 1950's.

##### 1. General History of Axon Stains

- Silver staining of neurons began in the late 1800's.
- Camillo Golgi was an Italian histologist.
- In 1880, he reported staining neural tissue with silver.
- In 1839, Louis Daguerre had devised silver-based photography.
- Golgi modified Daguerre's photographic processing techniques.
- Golgi pretreated fixed tissues with potassium dichromate.
- Then he soaked the tissue in silver nitrate.
- The entire neuron has a strong affinity for silver salts.
- Golgi's stain showed a neuron in three dimensions.
- This delineated the full arborization of dendrites and axon.
- The Golgi technique was idiosyncratic.
- It stained cleanly only a small number of a tissue sample's neurons.
- Santiago Ramon y Cajal was a Spanish histologist.
- Beginning in 1890, Cajal studied silver-stains neural tissues.
- He mapped the cellular architecture of a wide variety of nervous systems.

Make each sentence spare and declarative. Aim for the form: *Jane ate ginger cookies*. Write each sentence as a simple, transitive statement. Use only few and well chosen adjectives, and try to avoid adverbs.

I turned my rough paragraph into this list of simpler sentences:

#### A. Currently Accepted General Statement

##### 1. General History of Axon Stains

- Silver staining of neurons began in the late 1800's.
- Camillo Golgi was an Italian histologist.
- In 1880, he reported staining neural tissue with silver.
- In 1839, Louis Daguerre had devised silver-based photography.
- Golgi modified Daguerre's photographic processing techniques.
- Golgi pretreated fixed tissues with potassium dichromate.
- Then he soaked the tissue in silver nitrate.
- The entire neuron has a strong affinity for silver salts.
- Golgi's stain showed a neuron in three dimensions.
- This delineated the full arborization of dendrites and axon.
- The Golgi technique was idiosyncratic.
- It stained cleanly only a small number of a tissue sample's neurons.
- Santiago Ramon y Cajal was a Spanish histologist.
- Beginning in 1890, Cajal studied silver-stains of neural tissues.
- He mapped the cellular architecture of a wide variety of nervous systems.
- The architecture of a neuron determines its function.
- *Degeneration and Regeneration of the Nervous System* (1928) summarizes Cajal's work.
- Stephen W. Ranson was an American histologist.

- Beginning in 1914, he used silver stains to map neuroanatomy.
- David Bodian was an American histologist.
- In 1936, he reported a new silver stain for neurons.
- Bodian’s technique used solutions of silver protein with metallic copper.
- His technique was simpler and more reliable than Golgi’s.
- It stained the majority of axons in a tissue sample.
- Silver stains give detailed views of the three-dimensional structure of individual nerve cells.
- Until the development of electron microscopic histology, neurohistology depended on silver stains.

### 2.2.9.2. Nonessentials

A good scientific paper is crisp and to-the-point. This is a time to look objectively at your writing and to remove extraneous sentences.

Check each sentence against the point of the paragraph.

- If the sentence is tangential, with details unnecessary for a clear presentation, take the sentence out.
- If the sentence duplicates other sentences, take it out.
- If the sentence contains only non-scientific color or details of human interest, take it out.

From my list, I removed:

- Tangents  
*Stephen W. Ranson was an American histologist.  
Beginning in 1914, he used silver stains to map neuroanatomy.*
- Unnecessary details  
*Golgi pretreated fixed tissues with potassium dichromate.  
Then he soaked the tissue in silver nitrate.  
The architecture of a neuron determines its function.  
Bodian’s technique used solutions of silver protein with metallic copper.*
- Duplicated ideas  
*Silver staining of cells is a variant of photographic developing techniques.  
Silver stains give detailed views of the three-dimensional structure of individual nerve cells.*
- Nonscientific color and details of human interest  
*Camillo Golgi was an Italian histologist.  
Santiago Ramon y Cajal was a Spanish histologist.  
David Bodian was an American histologist.*

### 2.2.9.3. Rearrange Your Ideas into a Natural Sequence

Reorder the list of remaining sentences so that each follows logically from the preceding sentence. If a sentence introduces a new idea, let it begin a new list by separating it from its predecessor by an empty line.

My reordered list became:

A. Currently Accepted General Statement

1. General History of Axon Stains

- a) In 1839, Louis Daguerre had devised silver-based photography. The entire neuron has a strong affinity for silver salts. Silver staining of neurons began in the late 1800's. In 1880, Camillo Golgi reported staining neural tissue with silver. Golgi modified Daguerre's photographic processing techniques. Golgi's stain showed a neuron in three dimensions. His stain delineated the full arborization of dendrites and axon.
- b) Beginning in 1890, Santiago Ramon y Cajal studied silver-stained sections of neural tissues. He mapped the cellular architecture of a wide variety of nervous systems. *Degeneration and Regeneration of the Nervous System* (1928) summarizes Cajal's work.
- c) The Golgi technique was idiosyncratic. It stained cleanly only a small number of a tissue sample's neurons. In 1936, David Bodian reported a new silver stain for neurons. Bodian's technique was simpler and more reliable than Golgi's. It stained the majority of axons in a tissue sample.
- d) Until the development of electron microscopic histology, neurohistology depended on silver stains.

#### 2.2.9.4. Reassemble Paragraphs

Now you will have one or more lists of sentences, each representing a single idea.

Look at each list, and decide whether its main idea is necessary for this particular part of the outline. If not, find the part of the outline where it belongs, and put it there.

In my example, the third list (list c) goes beyond general history and introduces the specific stain—the Bodian stain—that is the central subject of my paper. Therefore, I moved this set of sentences to the later topic that introduces the Bodian stain.

Take the lists that remain, and string their sentences back together to form paragraphs. Merge orphan sentences into one of the fuller paragraphs.

#### 2.2.9.5. Smooth Transitions

At long last, you have a draft of a section of your paper. It is time to make it readable.

Start from the beginning, reading and listening with your inner ear. Fix awkward words or phrases. Smooth the transitions between sentences, and cut out repetitive words and phrases.

For my paper, the first reassembly and smoothing led to:

A. Currently Accepted General Statement

1. General History of Axon Stains

Silver staining of neurons began in the late 1800's, when Camillo Golgi reported staining neural tissue with silver. In 1839, Louis Daguerre had

devised silver-based photography. Golgi found that the entire neuron has a strong affinity for silver salts. Golgi then modified Daguerre's photographic processing techniques. Golgi's stain showed neurons in three dimensions. The stain delineated the full arborization of dendrites and axons. Santiago Ramon y Cajal used Golgi's stain and mapped the cellular architecture of a wide variety of nervous systems. *Degeneration and Regeneration of the Nervous System* (1928) summarizes Cajal's work. Until the development of electron microscopic histology, neurohistology depended on silver stains (Santini 1975, Parent 1996).

... It's time to take another break from writing. ...

## 2.2.10. Polishing

### 2.2.10.1. Reworking the Text

Here you are, at your desk again. Pick up the draft of your paper, and work through it, one paragraph at a time. For each paragraph, ask:

- Does it tell a single coherent story?
- Is it self-contained?
- Does it start with a summary statement?
- Do the following sentences explain, expand, and develop the initial summary statement?
- Do the ideas wander?
- Are there extraneous ideas?

Do your best to fix the problems.

In my draft, I consolidated sentences, cut unessential words, and simplified the exposition. I ended up with:

#### A. Currently Accepted General Statement

##### 1. General History of Axon Stains

Silver staining of neurons began in the late 19th century, when Camillo Golgi (1880) modified Louis Daguerre's (1839) photographic development techniques for histology. Golgi found that the entire nerve cell has a strong affinity for silver salts, and his new silver stain highlighted the full three-dimensional arborization of a neuron's dendrites and axon. With Golgi's stain, Santiago Ramon y Cajal (1928) then comprehensively mapped the cellular architecture of a wide variety of nervous systems. These silver stain studies were the basis of all neurohistology before the development of histologic electron microscopy in the 1950's.

### 2.2.10.2. Reworking Ten More Times

To create text that speaks simply, you must polish the draft over and over. Chose different tasks each time you sit down.

- One time, trim words and phrases that are repeated unnecessarily.

**A. Currently Accepted General Statement**  
**1. General History of Axon Stains**  
 Silver staining of neurons began in the late 19th century, when Camillo Golgi (1880) modified Louis Daguerre's (1839) photographic development techniques for histology. Golgi found that the entire nerve cell has a strong affinity for silver salts, and his new silver stain highlighted the full three-dimensional arborization of a neuron's dendrites and axon.



**A. Currently Accepted General Statement**  
**1. General History of Axon Stains**  
 Silver staining began in the late 19th century, when Camillo Golgi (1880) modified Louis Daguerre's (1839) photographic development techniques for histology. Golgi found cell has a strong affinity for silver salts, and his new silver stain highlighted the full three-dimensional neuron's dendrites and axon.

- Another time, make sure that the verbs are as active, transitive, and specific as possible.

**A. Currently Accepted General Statement**  
**1. General History of Axon Stains**  
 Silver staining of neurons began in the late 19th century, when Camillo Golgi (1880) modified Louis Daguerre's (1839) photographic development techniques for histology. Golgi found that the entire nerve cell has a strong affinity for silver salts, and his new silver stain highlighted the full three-dimensional arborization of a neuron's dendrites and axon.

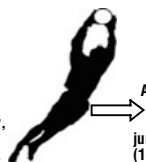

**A. Currently Accepted General Statement**  
**1. General History of Axon Stains**  
 Silver staining of neurons began in the late 19th century, jumped Camillo Golgi (1880) modified Louis Daguerre's (1839) photographic development techniques for histology. Golgi found that the entire nerve cell has a strong affinity for silver salts, and his new silver stain highlighted the full three-dimensional arborization of a neuron's dendrites.

- When the wording is vague or generic, add brief explanatory detail. For instance, if you read:

“In his lab, cells were studied”

rewrite the sentence with an active, transitive verb and with more detail:

“Using a camera lucida, he drew the shapes of cells from the intestinal tracts of fixed murine tissues”

or

“He and his lab associates recorded the shapes of nerve cells”

or

“He had his students measure the sizes of mitochondria in muscle cells”

- In one of your work sessions, read through each paragraph quickly to see how smoothly it flows. If a sentence repeats something that you’ve already read, trim the repetitive words or cut out the sentence entirely. If a sentence seems to pop up out of nowhere, add more of an explanatory introduction or put the sentence elsewhere in the text.
- As you read through the paragraph, you may find yourself stopping and looking back.

Perhaps there are pronouns *it*, *they*, *he*, *she*, *who*, *which*, *that* that do not clearly refer to only one noun.

pencil  
it ↗ chair

Or, if pronouns are not the problem, perhaps you are stopping because the connection between ideas is missing.

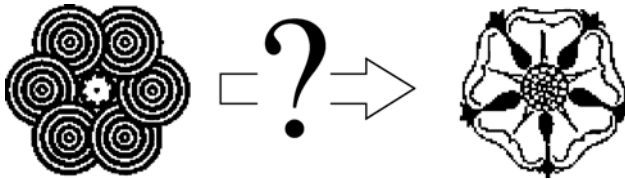

For example, in my drafts, I had written:

“For his silver stain, Golgi modified Louis Daguerre’s 1839 photographic development techniques.”

When I reread this sentence, I stopped. I had to remind myself what the actual connection was between *silver stains* and *photography*. I fixed the sentence by explicitly specifying the connection:

“For his silver stain, Golgi modified Louis Daguerre’s 1839 recipes for developing *silver iodide* photographs.”

– Your reading can also be slowed when the ideas jump back and forth. If the paragraph has a halting rhythm, smooth it by rearranging the order of the ideas.

For example, when reading one of my drafts, I found myself being led from Camillo Golgi to Louis Daguerre and then bouncing back again to Golgi:

“Silver staining of neurons began in the late 19th century, when Camillo Golgi (1880) modified Louis Daguerre’s 1839 recipes for developing silver iodide photographs. Golgi found that the entire nerve cell has a strong affinity for silver salts . . .”

The narrative flowed more smoothly after I reordered the sentences so the second, abrupt reference to Golgi disappeared:

“Silver staining of neurons began in 19th century, when Camillo Golgi found that nerve cells have a strong affinity for silver salts. By 1880, he had modified Louis Daguerre’s 1839 recipes for developing silver iodide photographs and had created a silver stain for fixed neural tissues.”

Each time you pick up your manuscript, imagine that someone else has given it to you to correct and clean up. Look at it with a critical editor’s eye.

- *Make the wording precise and clear.* For example, if you find “good stain,” replace it by the particular *kind* of “good,” such as “easily visible,” “cell-specific,” “resistant to fading,” “highly reproducible,” “safe to use,” or “easily applied.”
- *Cut nonessential words.* For example, if you find the sentence “He thoroughly investigated many avenues of staining,” trim it to “He tried many stains.”
- *Simplify.* Appendix B at the end of this book shows how to simplify a variety of excessively-tangled phrasings. Work hard to make your sentences read smoothly, so that the wording does not distract from the content.
- *Focus.* A common problem is putting too many ideas in one, long paragraph. Keep each paragraph focused on a single point.

### 2.2.11. Examples

As examples, here are a number of well-written paragraphs from a wide variety of scientific articles. Even when their content is quite technical, these paragraphs are short, clear, logical, complete, and directed to a single point.

- A report on the apparent disintegration of nitrogen atoms by radioactive bombardment (Rutherford, 1919):

Since the anomalous effect was observed in air, but not in oxygen, or carbon dioxide, it must be due either to nitrogen or to one of the other gases present in atmospheric air. The latter possibility was excluded by comparing the effects produced in air and in chemically prepared nitrogen. The nitrogen was obtained by the well-known method of adding ammonium chloride to sodium nitrite, and stored over water. It was carefully dried before admission to the apparatus. With pure nitrogen, the number of long-range scintillations under similar conditions was greater than in air. As a result of careful experiments, the ratio was found to be 1.25, the value to be expected if the scintillations are due to nitrogen.

- A report on the Kaposi’s sarcoma–associated herpesvirus (KSHV) effects on infected human cells (Glaunsinger and Ganem, 2004): (KS = Kaposi’s sarcoma)

Given the powerful constitutive signaling activity of vGPCR and its intrinsic proangiogenic character, one paradox has been why KS develops so infrequently after KSHV infection. In Western societies, where 2–7% of the population is KSHV infected, KS is largely limited to those developing HIV infection or receiving iatrogenic immunosuppression. The attenuation of VEGF and other vGPCR-dependent gene induction events by KSHV-induced shutoff leads us to propose that only infections with extensive lytic replication, such as those that may occur during cellular immune dysfunction, can generate sufficient VEGF to contribute meaningfully to KS progression. This inference accords well with clinical observations that link KS progression to elevated levels of circulating KSHV DNA (18).

- A report on the effects of three natural agonists on the contraction of smooth muscle in lung airways (Perez and Sanderson, 2005):

Because a cholinergic pathway has been proposed as a mechanism by which 5-HT induces airway contraction in trachea and isolated lungs (Levitt and Mitzner, 1989; Eum et al., 1999; Fernandez et al., 1999; Held et al., 1999; Moffatt et al., 2004), we examined the effect of atropine on the 5-HT responses of lung slices to determine if any 5-HT effects occurred indirectly. Atropine (1  $\mu$ M) had no effect on the airway contractile response (Fig. 7B) when added, either before or after exposure to 1  $\mu$ M 5-HT. By contrast, 1  $\mu$ M atropine totally abolished the airway contractile response induced by 1  $\mu$ M ACH. Similarly, 1  $\mu$ M atropine induced the full relaxation of an airway that was precontracted with ACH (Fig. 7B). These results indicate that 5-HT does not act via muscarinic receptors in the small airways of mice.

- A report examining the effect of matrix metalloproteinase inhibitors on healing after periodontal surgery (Gapski *et al.*, 2004):

Although periodontitis is initiated by subgingival microbiota, it is generally accepted that mediators of connective tissue breakdown are generated to a large extent by the host's response to the pathogenic infection (1). In a susceptible host, microbial virulence factors trigger the release of host-derived enzymes such as proteases (e.g., matrix metalloproteinases [MMPs]) which can lead to periodontal tissue destruction (2–4). Collagenases, a subclass of the MMP family, are a group of enzymes capable of disrupting the triple helix of type I collagen—the primary structural component of the periodontium—under physiological conditions. Elevated levels of collagenases and other host-derived proteinases (e.g., cathepsins, elastase, tryptases/trypsin-like proteinases) have been detected in inflamed gingiva, gingival crevicular fluid (GCF), and saliva of humans with periodontal disease (5–7).

- A report consolidating evidence of the speed of extinction of North American dinosaurs (Fastovsky and Sheehan, 2005):

Like the dinosaur extinction, mammalian evolution in the early Tertiary of North America has been evaluated quantitatively (Maas and Krause, 1994; Alroy, 1999; Archibald and Deutschman, 2001). All agree that earliest Tertiary mammals underwent high rates of speciation leading to a steep increase in rates of diversification during the first 5 m.y. of the Tertiary (Fig. 4). Indeed, seventeen of the eighteen orders of extant placental mammals did not exist before the K-T boundary (Archibald, 2002).

- A report on the relatively low number of studies on motor control in the psychological literature (Rosenbaum, 2005):

A third reason to expect a growth of interest in motor control is that there is an expanding appreciation of the computational challenges of skilled movement. Although humanoid robots can walk in controlled environments (Sony QRIO Honda Asimo), can vocalize (KRT-v.e; Kagawa University, Takamatsu, Japan), can smile and frown (WE-4R; Waseda University, Tokyo, Japan), can play the trumpet (Toyota's Partner robot), and can hit baseballs (University of Tokyo), they are poor



at performing in open-ended situations where novel movements are required (see – <http://informatiksysteme.pt-it.de/mti-2/cd-rom/index.html>). Thus, robots cannot clear tables at restaurants, make beds in hotel rooms, or open and inspect luggage at airports. Engineers hoping to build better robots have become interested in biological perception and action to improve robot design. Their interest in this topic may spur more psychological research on motor control and, from there, the connections between mental life and behavior.

### 2.2.11.1. The End

After a while, your text will become harder and harder to polish, and, eventually, you'll hit the end of your ability to improve the writing. It's time to stop and to let your text graduate.

When I came to the end of my polishing ability, the first paragraph of my Introduction read:

#### A. Currently Accepted General Statement

##### 1. General History of Axon Stains

Silver staining of neurons began in the 19th century, when Camillo Golgi found that nerve cells have a strong affinity for silver salts. By 1880, he had modified Louis Daguerre's 1839 recipes for developing silver iodide photographs and had created a silver stain for fixed neural tissue. Golgi's silver stain cleanly highlights the full three-dimensional arborization of the axon and dendrites of individual neurons. With Golgi's stain, Santiago Ramon y Cajal (1928) mapped the cellular architecture of a wide variety of nervous systems. His comprehensive silver stain studies remain the foundation of neuroanatomy (Santini 1975, Parent 1996).

## 2.3. Advice to Speakers of Other Languages

Scientific logic is the same in all languages. If you are more comfortable using a language other than English, then first write your paper in your own language. After it is complete, translate it (or have someone else translate it) into English.

To make the eventual translation clearer, try to follow these suggestions as you write:

#### Words

- Use simple verbs: write "use" not "employ."
- Turn adjectives into numbers: write "2" not "several."

#### Phrases

- Don't use metaphors. Often they do not translate properly. For example, write "the mixture could not be poured" or "beads of the mixture stuck to the sides of the tube" not "the mixture was as thick as glue."

#### Sentences

- Make each sentence short.
- Put only one idea into each sentence.

- Ignore the sound and the rhythm of the sentence. Disregard smooth, flowing speech.

#### Paragraphs

- Make paragraphs short.
- In each paragraph, arrange the sentences in simple logical order.

After your paper is translated, it is important to have it edited by another person who speaks English comfortably.

### 3. NUMBERS

Science aspires to objectivity, but this is a struggle because the words in scientific papers come from subjective vocabularies. One person’s “hot” is another person’s “warm,” and one person’s “pink” is another person’s “red.” In contrast to words, numbers are universally agreed on, and, in this way, numbers are objective.

Not only are numbers objective, they also have special non-linguistic powers. Numbers, for instance, can be ordered.

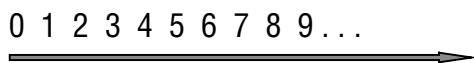

Ordering allows you to use the elemental comparisons “greater than,” “equal to,” and “less than” precisely and unambiguously.

**Example**

– How should we order these three sets of dots?

$\begin{matrix} \cdot\cdot & \cdot\cdot & \cdot\cdot \\ \cdot & \cdot & \cdot \end{matrix}$

– At the moment, we can order them in any way we wish. By specifying a rule that assigns numerical values to the sets of dots, however, we can put them in one generally-agreed-upon order. For instance, we could use the Braille rule, in which dot patterns are assigned numbers as follows:

$\begin{matrix} 1 \cdot & 3 \cdot\cdot & 5 \cdot\cdot & 7 \cdot\cdot\cdot & 9 \cdot\cdot \\ 2 \cdot & 4 \cdot\cdot & 6 \cdot\cdot & 8 \cdot\cdot & 0 \cdot\cdot \end{matrix}$

– Now the sets of dots have the numerical values 4, 6, and 8. Therefore, their order becomes:

$\begin{matrix} \cdot\cdot & \cdot\cdot & \cdot\cdot \end{matrix}$

In addition to giving us the power of order, numerical statements can be embedded in an idealized abstract continuum, which is the basis for mathematical induction.

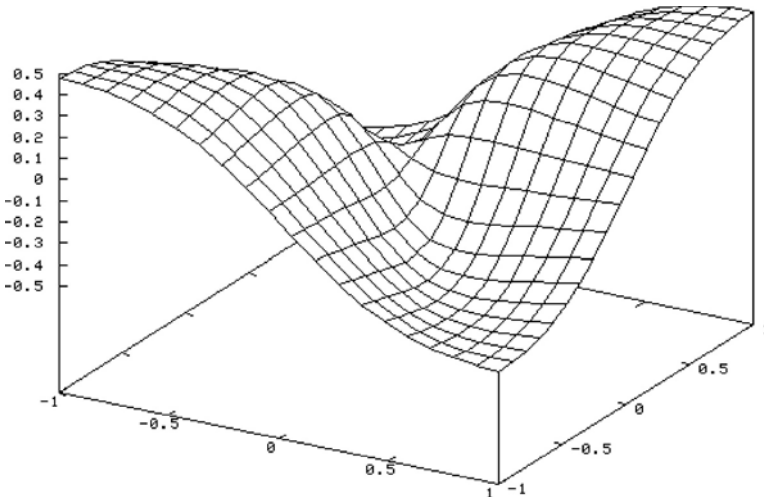

Mathematical induction is a mode of travel. It begins with a particular mathematical statement and it then moves through a continuum by infinite, minuscule, automated steps. You start at one place in the continuum, and, you initiate a chain of iterative events, each set off by the previous event, like the falling of a line of dominoes.



Once started, the dominoes fall along a preordained path stretching far into the distance. They fall with an inevitability that assures you that wherever they lead, it is to a place connected absolutely to your starting point. With induction, you can travel

great distances, and you can make reasoned numerical statements about places as yet unvisited and things as yet unseen.

To enlist the objectivity and the far-reaching connectivity of numbers, quantify your observations.

### 3.1. Tables

#### 3.1.1. Organize Data Using Variables that Have Been Measured Directly

All real world phenomena are complex. Even the cleanest experiments will produce data with variation. When you present complex data in your Results section, you will help your reader by arranging the information in a table. Building a table forces you to face the variation in your results and to find order in the complexities of your data.

To start, choose two variable features (or, simply, “variables”) of your data and organize your observations in a table using these variables.

#### **Example**

*Experiment* Description of a new hybrid flower



*Data* Counts of the number of petals on 500 hybrid flowers

*Table variables*

- a) the flower identification number
- b) the number of petals on that flower.

*Table*

flower id number	number of petals
1	17
2	18
3	19
4	18
5	18
6	16
7	17
...	...

Let's look at the choice of variables in this example. "Number of petals" is the direct output of the study. It would seem to be a useful variable to report, and it feels like a legitimate aspect of the data. To make the idea of "legitimate" more precise, we need a rule.

**Rule for choosing which variables to report**

*The legitimate data of a scientific paper are the unadjusted, spontaneous results that come from following a given recipe. Legitimate data come only from explicitly-described operations.*

"Number of petals" is a legitimate variable because it is data discovered by following a research recipe described in the protocol for the experiment. Is "flower id number" also a legitimate variable? This question translates into:

**Does the protocol of the experiment give us a recipe for discovering flower identification numbers?**

Using our *Rule for choosing*, "flower id number" is a legitimate variable to include in a table in your Results only if your Materials and Methods give objective instructions for assigning identification numbers. In other words, identification numbers cannot have been assigned arbitrarily or by whim, instead they must have been determined by a recipe that any researcher could follow. Acceptable recipes include:

- plants are numbered in the order that they bloom
- plants are numbered in the order of their planting
- plants are numbered in the order of their heights

In these cases, "flower id number" is actually a stand-in for a more direct and descriptive variable, such as "date of blooming" "date of planting" or "height." Here, it will be much clearer to your reader if you refer directly to the actual variable that you have measured.<sup>2</sup>

### **3.1.2. Put Numerical Order into Your Tables**

Numbers can be naturally ordered. Use that organizing feature by ordering the numerical data in your tables.

<sup>2</sup> If, on the other hand, some feature of your data—such as "flower id number"—is only a bookkeeping tool, don't include it in your Results. For example, if your experimental protocol does not make any distinction between flowers—if "a flower is a flower is a flower" —then don't confuse your reader with extraneous, illegitimate variables. In this case, keep your bookkeeping marker "flower id number" out of your paper.

**Example**

*Data* Counts of the number of petals on 500 hybrid flowers

*Table Variables*

- a) the number of petals on each flower

*Table*

number of petals	number of flowers
15	6
16	54
17	114
18	221
19	91
20	14

total = 500

**Example**

*Data* Counts of the number of petals on 500 hybrid flowers

*Table Variables*

- a) the number of petals on each flower  
b) the height of each plant

*Table*

height (cm)	number of plants with N petals					
	N=15	N=16	N=17	N=18	N=19	N=20
<11	5	1	0	0	1	0
11-15	0	34	26	27	0	0
16-20	1	18	68	167	75	6
21-25	0	1	20	26	13	1
>25	0	0	0	1	0	7

total = 500

To summarize:

- When your Results include sets of numbers, present the data in a table.
- Build your tables of legitimate variables, that is, numbers that come directly from recipes in the Materials and Methods section of your paper.
- Inside your tables, arrange the data in numerical order.

### 3.1.3. Add a Figure Legend

All figures—and this includes tables—must be referred to in the main text of your paper. In this text reference, you should include a brief summary of the figure. Don't

just point to the figure, writing: “The number of petals was counted (see Table 1).” Instead, describe the content of the table; for example: “Table 1 lists the number of petals on each of 500 flowers of the new hybrid plants. The number of petals ranged from 15 to 20. Almost 85% of the flowers had 17, 18, or 19 petals.”

The figures themselves should be self-contained, so that they can be understood without reference to the text. Give the figure a title and an explanatory figure legend, even if you repeat some information that is in the main text.

### 3.1.4. Example of a Complete Table

*Table 1. Our new hybrid of Rudbeckia hirta has yellow flowers that appear much like the wild variety. Of 500 hybrid flowers grown in a controlled temperature and humidity greenhouse, 44% had 18 petals. Eighty-five percent had either 17, 18, or 19 petals. No flowers had less than 15 or more than 20 petals.*

The Number of Petals On Hybrid Flowers	
Number of petals	Number of flowers
15	6
16	54
17	114
18	221
19	91
20	14
	<b>total = 500</b>

Other examples can be found in Section 2.3.5.2.2.2 of Chapter 2.

## 3.2. Statistics

Using statistics properly is a skill. Even prepackaged statistical programs need to be used thoughtfully. No matter how much practice you have had with numerical analysis, never be shy about asking for advice from researchers with more experience. If you are fortunate enough to have access to professional statisticians, consult them from the very beginning of your experiments.

In the following sections, I introduce the vocabulary and basic tools that you will need for any statistical analyses. To get to the next level of understanding, I recommend studying Freedman D, Pisani R, Purves R, 1997, *Statistics, 3rd ed.* Norton, New York.

### 3.2.1. Descriptive Statistics

When data pour out of your experiment, it helps to reduce the volume to a few characteristic numbers. These characteristic numbers are *descriptive statistics*.



Descriptive statistics are more than just summaries of the numerical data points. Statistics describe the whole *pile* of data. Statistics consider a data pile as a thing in its own right, with its own size, shape, and texture.



A statistical analysis takes the data pile and orders it

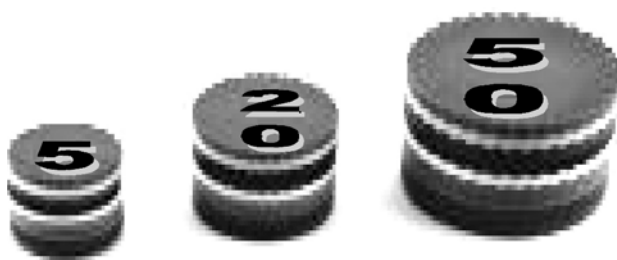

and then offers numerical descriptions of the ordered data.

Certain descriptive statistics are especially helpful, because they give you a direct intuitive feel for your data.

**Size**—The *size* is the total number of data points in the pile. Size is often represented by ‘*N*.’ The size of our pile of flower petal data is “ $N = 500$ .”

**Range**—The *range* is the distance between the smallest and the largest data values. It is the data pile’s full width. Our flower petal data has a range of: “min = 15 to max = 20.”

**Middle**—There are three commonly used middles.

- **Mean**—The *mean* is the center of mass, the balancing point of the data. This is the average data value. It is the *arithmetic mean*. For our flower petal example: “mean = 17.8.”
- **Mode**—The *mode* is the data value that occurs most often. It is the data pile’s maximum height. In our example: “mode = 12.”
- **Median**—The *median* is a number such that half of the data values are less than it and half are greater. In our example: “median = 12.” (If there is an odd number of data values, the median is a whole number. If there is an even number of data values, the median is the average of the two middle numbers; this can be a fraction.)

**Spread**—The *spread* is the compactness or dispersal of the data pile. If the numbers have little variation, the pile will be compact. If the numbers are more heterogeneous and variable, the pile will be spread out.

- **Standard Deviation**—A common measure of the spread of a pile of numbers is the *standard deviation*. The standard deviation is built from the deviations of each data point from the mean. A large standard deviation means that the pile of numbers is spread out; a small standard deviation means that the pile of numbers is compact.

### Standard Deviation

A very helpful statistical diagram of a pile of data shows the frequency of occurrence of each value laid out as a graph. These graphs are called histograms (see Histograms below).

Here is a histogram showing data from a study of the birth weights of babies. The hatched bars indicate how many babies were born in each weight class during the study. Most of these newborns ( $n = 113$ ) were in the 3133–3393 g (7.0–7.3 lb) weight class.

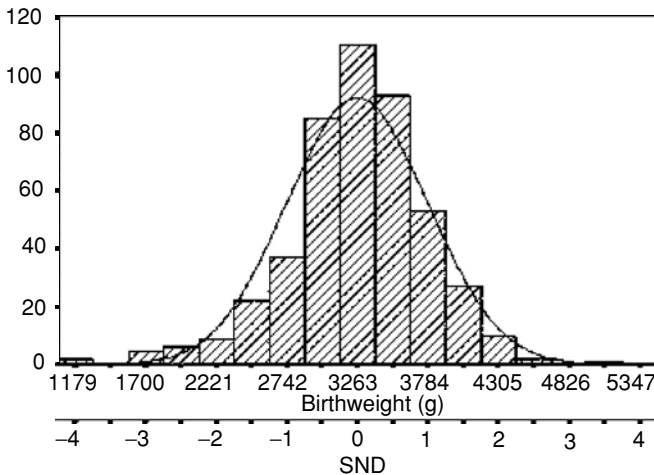

Drawn over the histogram is a continuous line showing how an idealized, bell-shaped normal curve might be fitted to the actual experimental data.

The standard deviation for the idealized curve is 521 g (1.1 lb). The bottom line shows the locations on the  $x$ -axis of 1, 2, 3, and 4 standard deviations away from the mean (3263 g). The properties of the standard deviation tell us that 68% of all the data values will be within  $-1$  and  $+1$  standard deviations from the mean and that 95% of all data values will be within  $-2$  and  $+2$  standard deviations of the mean (SND=standard deviations).

All statistics programs and many hand-held calculators can compute standard deviations.

- **Central 50%**—The limits of the central 50% of the data give a more intuitive measure of the spread of a data pile. These are the boundaries within which the

middle half of the data points lie. A narrow range indicates a compact distribution; a broad range indicates a dispersed distribution.

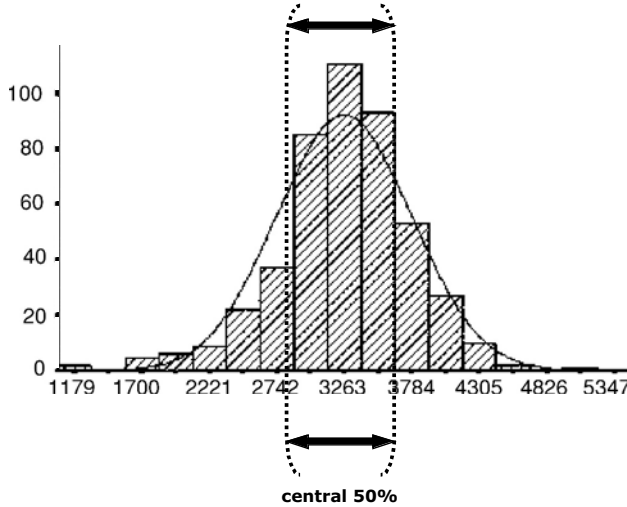

For the birth weight data, the central 50% of the weights are between 2909 g and 3617 g (i.e., 6.4–8.0 lb).

To find the 25th and 75th percentile values—the edges of the central 50% of the data—line up your data points in numerical order. Find the data point where 25% of the data points are less than it, and identify the value of that point as the lower limit of the central 50%. Then find the data point where only 25% of the data points are greater, and identify the value of this point as the upper limit of the central 50%.

### 3.2.2. Inferential Statistics

Pure mathematics exists in an abstract universe, parallel to the real world.

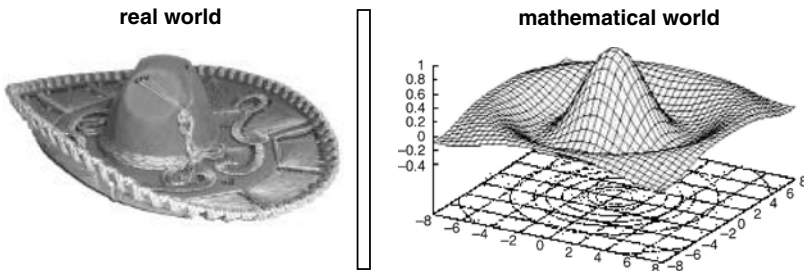

Inferential statistics is done in the mathematical universe. Inferential statistics imagines that a pile of numerical data in the real world is an astigmatic or incomplete snapshot

of numbers produced by a well-behaved and well-understood formula in the parallel mathematical universe.

For example, the following histogram of data collected in a real-world experiment might be imagined to be an imperfectly-seen version of a smooth curve in the mathematical universe.

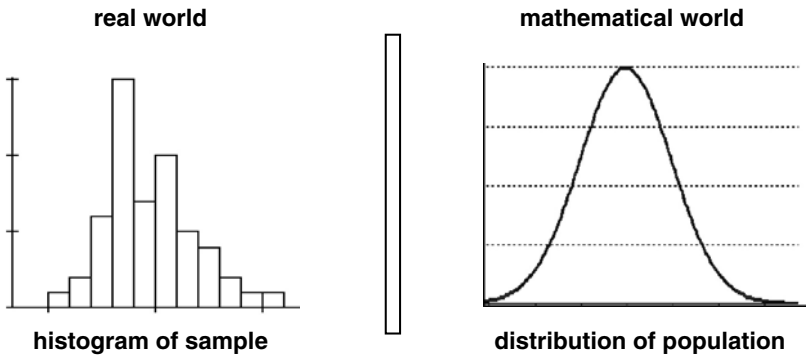

The pile of real world data is called the *sample*, and the output of the mathematical formula is the *population*. Inferential statistics infers the identity of the mathematical formula from the real-world sample. Statistical operations and judgments are then made by working on the formula inside the abstract mathematical universe.

### 3.2.2.1. The Normal Distribution

Among the touchstones used in the mathematical sciences is a particular formula that produces values with a shape called the *normal distribution*. (“Distribution” simply means “mathematical curve.”)

The normal distribution is a curve with a smooth, symmetrical, bell shape.

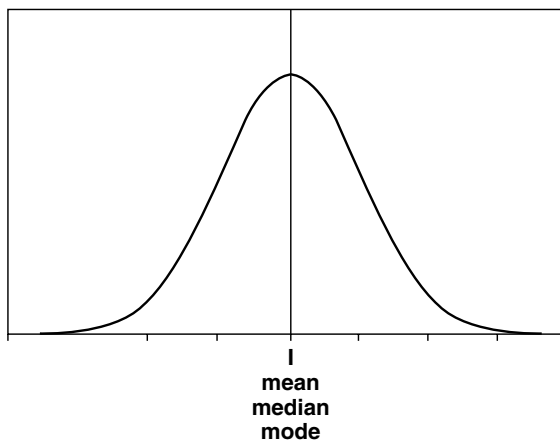

For a normal distribution, the *mean*, the *median*, and the *mode* each have the same value, and the exact shape of any particular normal distribution can be summarized with just two numbers, its *mean* and its *standard deviation*.

The normal distribution lives in the parallel mathematical universe. The flow of the distribution moves perfectly smoothly from value to value. The ends of the distribution extend infinitely in both directions from the mean.

In the real world, no set of data numbers can be arrayed so that their values grade with infinite smoothness along a continuum from point to point. No set of data numbers tails off gently and infinitely toward its lesser and higher values. Nonetheless, we frequently call real world data sets “normally distributed.”

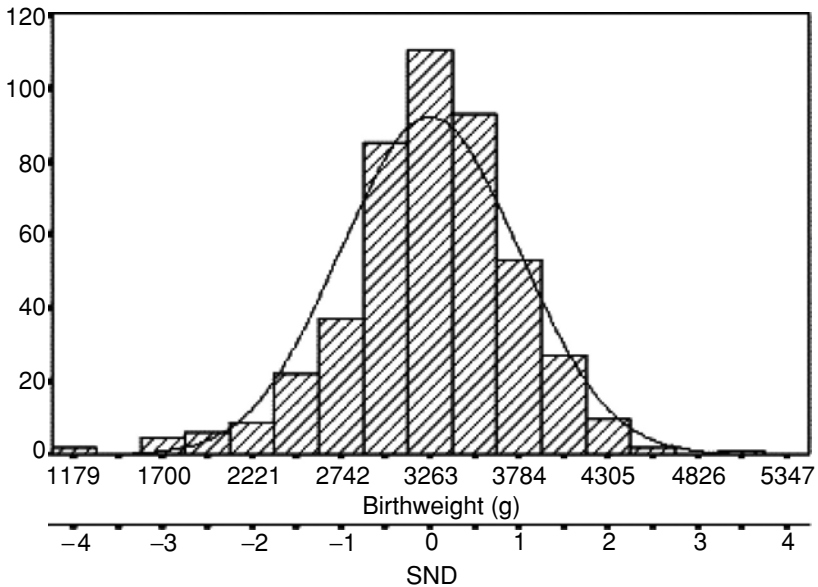

For example, a graph of the birth weights of babies has a shape like a normal distribution, and we could say that, from this data, the birth weights of babies are approximately normally distributed.

The mathematical properties of normal distributions make them tempting tools to statisticians. Moreover, many large sets of real world data can be well approximated as normal distributions. Therefore, normal distributions are frequently used in statistical analyses.

It is important to remember, however, that many sets of real world data are *not* normally distributed. For example, scores on colleges tests are usually concentrated asymmetrically in the upper percent numbers. Likewise, a histogram of the number of people dying at each age is not symmetric: it is heavily skewed toward old age.

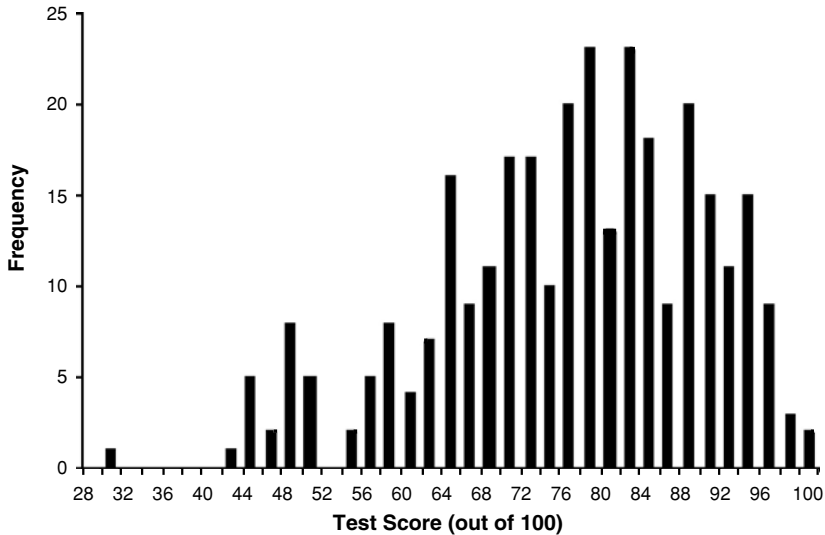

Take a close look at the shape of the distribution of your data before you make any statistical statements that are based on a normal distribution. If you are not certain whether your data match a normal distribution, ask a statistician for help.

### 3.2.2.2. The Null Hypothesis

In the Results section of your paper, you present your actual data, accompanied by histograms and descriptive statistics. It is in the Discussion section that you put your inferences, hypotheses, and preliminary conclusions.

When these inferences, hypotheses, and preliminary conclusions include statements such as “it is likely that,” “it is unlikely that,” “differs significantly from,” “is indistinguishable from,” “is probably,” “is the same as,” and “is not the same as,” try to add the precision of a numerical evaluation.

Inferential statistics provides the standard tools for giving numerical precision to comparative statements about data. With inferential statistics, you can assign numerical limits to your reasoning.

Inferential statistics usually tests the *null hypothesis*. When comparing two things, many inferential tests ask “How likely is it that these things are the same?” rather than “How likely is it that these things are different?”

#### **Null Hypothesis for Two Data Sets**

*Any apparent difference between two sets of data is null. Specifically, the two data sets can both be approximated by the same formula or distribution in the mathematical universe.*

### 3.2.2.3. Significance Tests

Inferential statistics uses significance tests to generate the numbers used to rank the strength of statements such as “this data is not the same as random numbers.” Many of the significance tests generate a probability  $P$  that the given data is a subset of a particular mathematical formula or distribution. These  $P$  values can range from 0 to 1, and “ $P < 0.05$ ” means that the probability is less than 5% that the data set is a part of the specified mathematical distribution. (Sometimes,  $P$  values are loosely rewritten as confidence levels—a  $P < 0.05$  is a confidence level of 0.95 (or 95%) that your data set is not a part of the specified mathematical distribution.)

By convention and when there are no other requirements in the experiment, two significance levels— $P < 0.05$  and  $P < 0.01$ —have been called “significant” in the texts of many science papers. It is best, however, to be explicit and to follow your use of the word ‘significant’ by the particular  $P$  that you have calculated. For example: “These data are significantly different from random ( $P < 0.02$ ).”

*t*-tests: One of the commonly used significance tests is the *t*-test. *t*-tests apply to data piles that have the shape of a normal distribution.

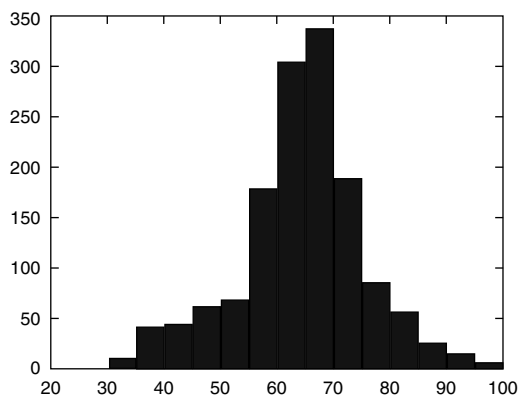

*t*-tests compare two piles of numbers and ask whether their means are so different that it is likely that the piles are distinct.

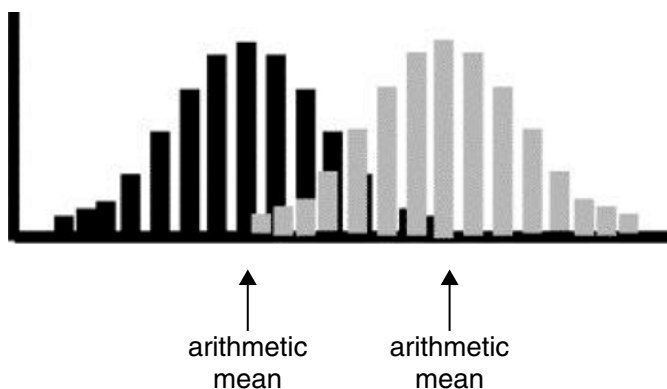

$t$ -test formulas are found in statistics texts and statistics programs. They require three descriptive statistics for each pile of numbers: the *size*, the *mean*, and the *standard deviation*.

When presenting your results from a  $t$ -test, the full statement would read: “A  $t$ -test found that the two data sets differ with a significance level of  $P < 0.05$ .” (Or, “A  $t$ -test found that the two data sets differ with a confidence level of 95%.”) This is usually abbreviated as: “The difference was significant ( $P < 0.05$ ,  $t$ -test).”

Remember to be precise. With this and many other significance tests, you are not testing whether two data sets are the *same*. You are only testing whether you have shown that they are likely to be different. A large  $P$  value, such as  $P > 0.25$ , does not mean that there is no difference between the data sets. It only means that your particular analysis has not shown a statistical difference between the data sets. When your comparison gives a  $P > 0.25$ , write: “Under these conditions, a significant difference could not be detected ( $P > 0.25$ ,  $t$ -test).” Don’t write: “These data sets are essentially the same ( $P > 0.25$ ,  $t$ -test).”

*Nonparametric Tests:*  $t$ -tests are parametric and, in particular, they depend on the mathematics of normal distributions. This means that the underlying process producing your data is presumed to produce normally distributed data when it operates long enough.

Parametric tests can relate data to mathematical distributions other than the normal distribution. Commonly referenced distributions include:

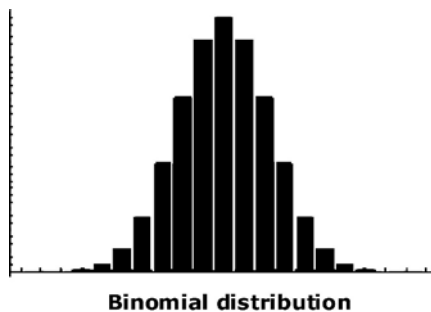
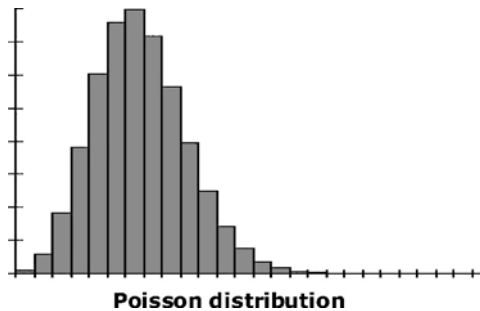



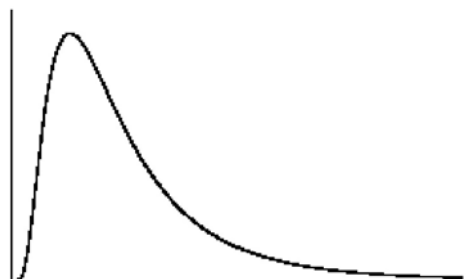

**Lognormal distribution**

In contrast, distribution-free or nonparametric significance tests do not compare data sets to specified mathematical distributions. The *chi-squared test* is a commonly used nonparametric test. Nonparametric tests that are analogous to *t*-tests include the *sign test*, the *Wilcoxon's matched-pairs signed-ranks test*, the *median test*, and the *Mann-Whitney U test*.

Nonparametric tests tend to be easy to use. The *Kolmogorov-Smirnov test*, for instance, is a simple non-parametric test for comparing two number piles. It has few requirements and can distinguish number piles that have different shapes, not just different means.

*Choosing a Significance Test:* When you need a significance test, do not begin with a particular one in mind. Instead, begin with a written list of the yes-or-no questions to which you would like to assign confidence levels. Questions that you might list include:

- Is my data normally distributed?
- Is my data random?
- Does my data match similar data generated by Dr. Smith?
- Does the data set I've generated using Recipe A differ from the data set I've generated using Recipe B?

Now pick a significance test that will directly answer your question(s) using the particular form of numerical data that your experiments have generated. It often takes advice to find the appropriate test. Read a statistics book, such as Freedman *et al.*, and don't be afraid to consult a statistician.

### 3.2.3. A Caution About Statistics

Statistics is carried out in the mathematical universe, where it is built of abstract, idealized images. The language of mathematical statistics is then carried over into our explanations of real world phenomena. The formulas become interpreters of our data. With the mathematical images in mind, we find ourselves saying that data should look a certain way. We call certain data points "good fits" and others "outliers."

Moreover, the formulas of the mathematical universe are often explained as idealized versions of the physical processes that we see in the real world. For example, the path of a thrown ball is often said to be a parabola, if there is no spin on the ball. But in the real world there *is* spin on the ball and there are also irregularities on its surface,

inhomogeneities in its weight distribution, air resistance, wind, barometric changes, and the occasional sudden rainstorm. The precisely delineated processes of the mathematical universe which give rise to parabolas are only pale images of the complex, messy processes that generate data in the real world.

Your data set has been generated in the real world. It will rarely fit the idealized images that we dream of in the abstract mathematical universe. Don't let your explanations of real world data be driven by those mathematical idealizations that are of necessity embedded in your statistical tools.

## 4. FIGURES

### 4.1. Basic Guidelines

Much of science is expressed through the logic of words and the logic of numbers. At the same time, humans are visual creatures, and, inside our brains, pictures can be understood without words or numbers. You need no words or numbers to comprehend this picture:



In the human brain, pictures go directly to visual centers. There, they register in the topology of the brain's cellular architecture. Pictures tell us things unavailable through words. You can bring more and different information to your readers by using pictures.

Any picture—photograph, diagram, drawing, or graph—can be a scientific figure. Figures that portray techniques should be put in the Materials and Methods section. Figures of data belong in the Results section. Figures of synthetic concepts, abstractions, theories, and models should be in the Discussion section. As with tables, figures must be referenced and explained in the text, and you should number your figures consecutively in the order of their text citations.

Even within the confines of a formulaic scientific paper, you can be creative with your figures. The most important constraint is that figures must be informative not entertaining. The information—be it a diagram of a procedure, a photograph of your experimental subject, a graph of your data, or a drawing of your hypothesis—must be clear and in the forefront.

There are a few general conventions that you can use as guides:

- a) Try to build your figures within an imaginary rectangle 1 unit high and 1.5 units wide.

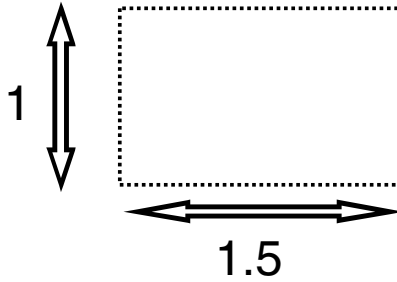

- b) Make the information flow from left to right. Array numbers so their magnitudes increase from left to right.

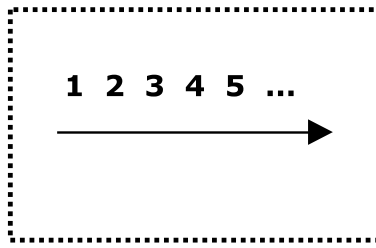

- c) The frame of the figure should be unobtrusive. In numerical figures, baselines (such as zero levels) and a scale should be indicated modestly at the bottom and at the left of the diagram.

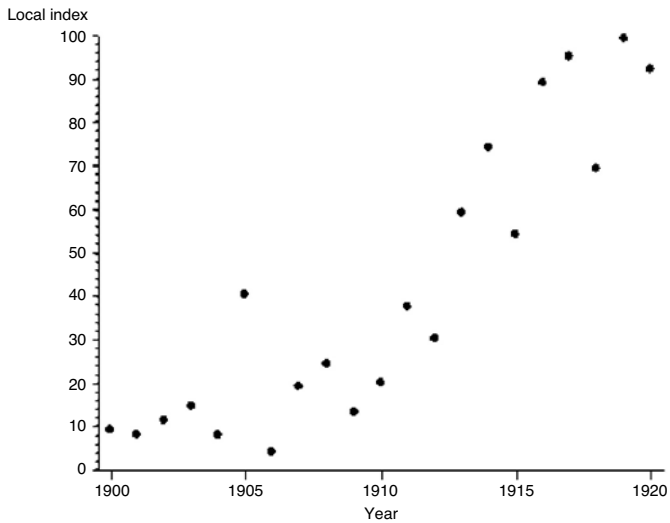

- d) Whenever possible, position words horizontally, not vertically, and make the lettering clear, unadorned, and well-spaced.
- e) Overall, a figure should look simple, clean, and professionally-produced.

## 4.2. Figure Legends

Each figure needs a legend. Together, a figure and its legend should be self-explanatory, a miniature report in themselves. Write the legends in spare phrases—complete sentences are not necessary. The first phrase in your legend is a title, and it should summarize the figure. Succeeding phrases or sentences give essential details. Definitions of symbols and abbreviations follow, and the legend ends with an indication of scale if it is needed.

*Example*

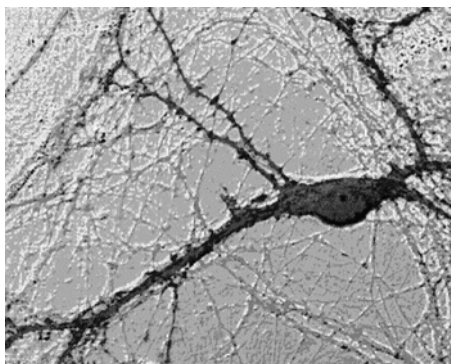

*Figure 2.* An embryonic neuron and axons in culture. The fixed culture was stained using Bodian with 10 min post-staining intensification. (DIC microscopy, bar = 10  $\mu\text{m}$ )

## 4.3. Graphs

When your data are numbers, graphs will show more visual detail than tables. Tables order data in lines, whereas graphs organize data in a full two-dimensional plane, so try to use graphs when you can.

### 4.3.1. Histograms

One simple graph is the histogram. A histogram, also called a “frequency-distribution diagram,” shows how many of your data points have each value. The range of data values is laid out along the  $x$ -axis, and the numbers of data points having each value are listed along the  $y$ -axis. In a histogram, the  $x$  values (the “classes” or measurement intervals for the values) must be divided into even intervals.

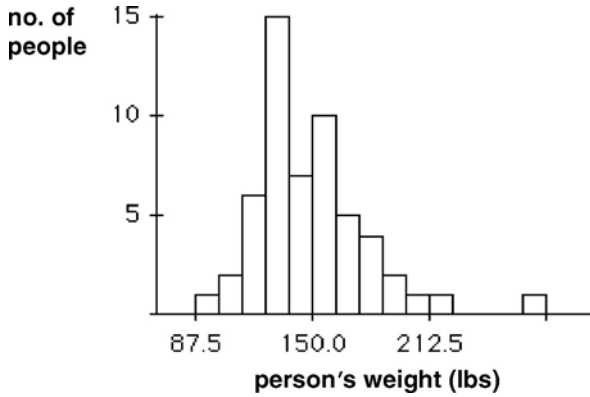

For our flower petal example, Table 1 (section 3.1.4, above) can also be presented as a histogram, Graph 1, where each flower is a data point and the number of petals on the flower is the value of that data point:

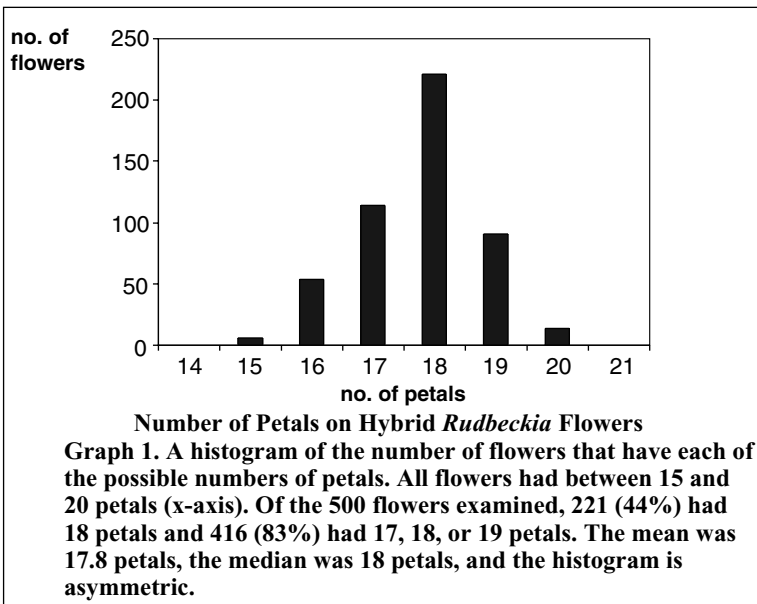

By expanding our table into a graph, we have turned a numerical pattern into a spatial pattern. It takes some thinking to understand the numerical pattern in Table 1, but we can immediately use visual logic to comprehend the spatial pattern in Graph 1.

A histogram is simple because it portrays only a single aspect or variable of your data points. When your research project records two or more variables of each data point, you can make histograms of the individual variables. For example, if we had counted the number of petals of each flower and also measured the height of the entire

plant, we could add an additional histogram showing the number of plants in each of the different height ranges that we found.

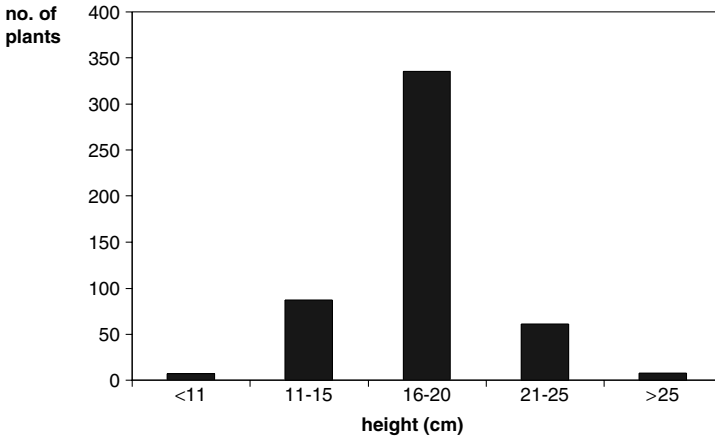

### 4.3.2. Scatter Plots

The two histograms—petal number and plant height—are independent data collections. They could just as easily be the results of two separate research projects. When more than one key variable has been recorded from the same data set in the same experiment, it is a good idea to make an independent histogram of each variable so that you can examine the pattern of the occurrence of that variable alone.

When your experiments record two key variables for each observation, however, you can also use a graph to look at the pattern of the co-occurrences of the variables. In a graph of co-occurrences, each *observation* is treated as a data point. The position of the point in the graph is established by the values of its two variables. The many points you have recorded will be scattered throughout the graph, so this graph is called a “scatter plot” or “scatter diagram.”

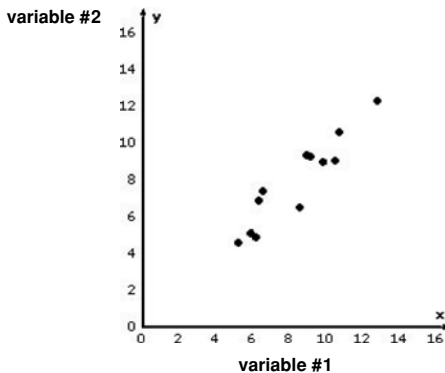

Scatter Plot of the Co-occurrence of Two Variables Measured in the Same Experiment

For example, a scatter plot of the co-occurrence of petal number and plant height, in our hybrid plant example, would have 500 points, one for each plant in the study.

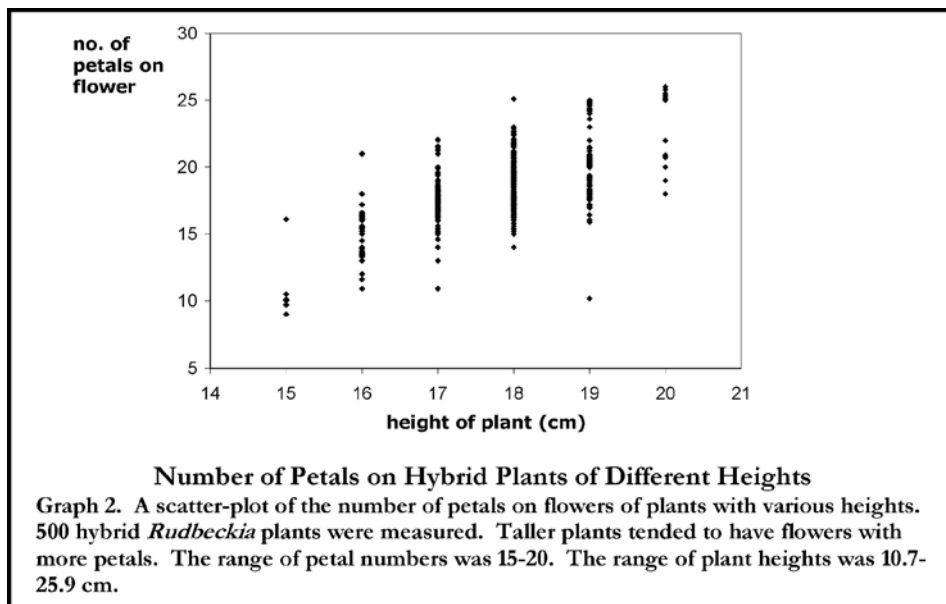

### 4.3.3. Correlation

A scatter plot immediately challenges you to wonder whether the two key variables that you have graphed are correlated.

On the one hand, there may be no correlation. It is always possible that the only relation between the two variables is that you have chosen to measure them both each time you collect data. For example, suppose that, for each data point, you measured the number of petals on a flower and the Dow Jones Industrial Average at that moment. It is hard to imagine a mechanism by which the values of these two variables would change together. Therefore, you would probably not look for a correlation.

On the other hand, suppose that, for each data point, you measured both the height of a plant and the number of petals on its flower. You could imagine mechanisms by which the values of these two key variables could change together. Therefore, you might look for a correlation.

A scatter plot of co-occurrences of the two variables is a good place to start looking for correlation between them. Begin with your eye and your innate ability to see patterns.



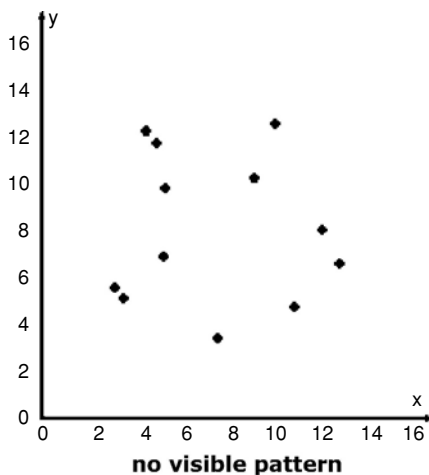
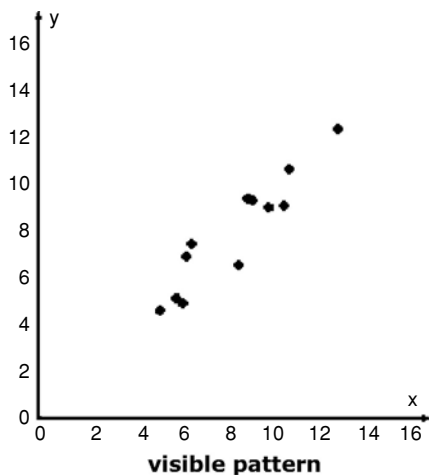

Ask yourself:

- Does it look like the points in your scatter plot have some order or form a pattern?
- Are the points clumped?
- Are the points more concentrated in certain areas?
- Do the points look like a simple shape, e.g., a line, a curve, a wave?

Then, before using any mathematical tools, write two sentences:

- (1) I \_\_\_\_ (think, do not think) I see a pattern.
- (2) The pattern looks like \_\_\_\_ (a heterogeneous random dispersal of points, a straight line, a curve, a sine wave, one major clump of points, dense points on the left grading to sparse points on the right, . . .).

Written simply and precisely, the essence of these sentences belongs in your paper. For example, “To the eye, the points in this scatter plot appear to lie along a straight line” or “To the eye, the points in this scatter plot are arranged in no recognizable pattern.”

Now try to use correlation statistics to assign numerical confidence levels to these sentences. Specifically:

- Sentence (1) (which proposes the presence or absence of a pattern) can often be given a confidence level by calculating a non-parametric correlation coefficient.
- Sentence (2) (which proposes the presence of a *particular* pattern) can often be given a confidence level when the apparent pattern is a simple curve.

Experience is needed to make useful statistical statements about patterns. This is a good point at which to consult a statistician.

A scatter plot is a visual description of your data. Put the plot in your paper even if you don't see a clear pattern in the points. A reader with a better eye may discover a

pattern that you have not seen. And, if your data truly has no pattern, a scatter plot of the full data can show the heterogeneity convincingly.

### 4.4. Aesthetics of Numerical Figures

Tufte (Tufte, 2001, *The Visual Display of Quantitative Information*, 2nd ed, Graphics Press, Cheshire, CT) gives a superb survey and critique of the styles of pictures that have been used to present numerical information.

Tufte points out that figures about data should devote most of their “ink” to the data. Most of the content of a drawing should be data, not framework, gridlines, decorations, or background.

Explanatory features, such as highlighting, arrows, and inside-the-graphic notes should be sparse. Artistic additions, such as filigrees to enhance data points or three-dimensional expansions of one- or two-dimensional objects, invariably distort the actual information. Keep the drawing clean, airy, and junk-free, says Tufte. Let the eye take in the pure data, both in its broad sweep and in its detail.

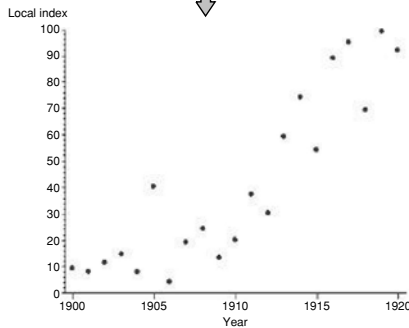
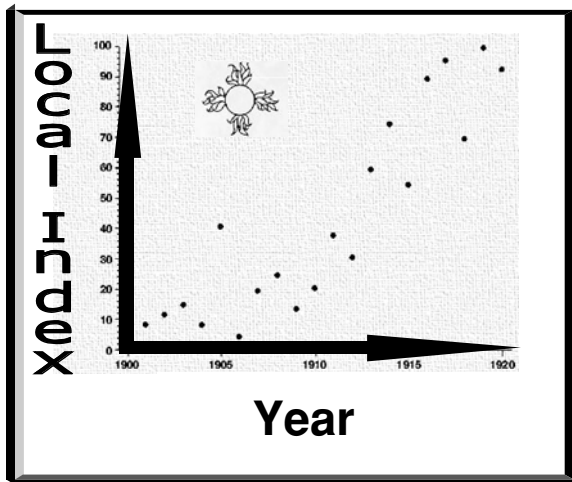

## 5. SCIENTIFIC PATTERNS

Patterns in a data set can jump out at us when the data is presented visually, as it is in a graph.

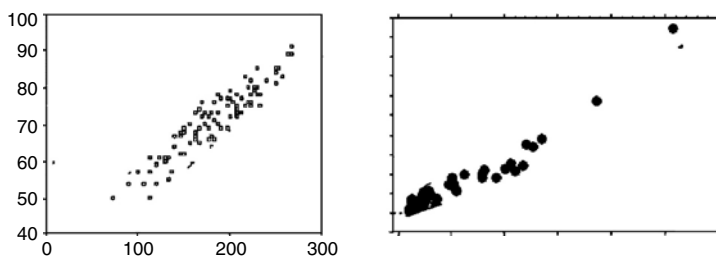

Nevertheless, as a device for revealing patterns in complex data sets, visual impressions are a two-edged sword. Our brains will create images where no reproducible patterns exist, and we can see mirages—clumps, lines, curves, waves, shapes—in most graphs that are thick with data.

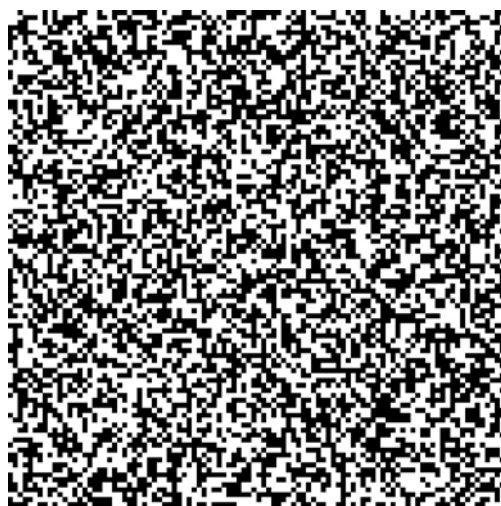

Random Dots

This leads me to a general caution about *any* pattern found by a scientist. The universe is large, and its patterns are uncountable. Science, however, is concerned with only a small fraction of the patterns in the universe. Science deals only in those patterns that are reproducible. Scientifically, it is useless for you to describe today's pattern of raindrops on your hat. Raindrops splash in endless unpredictable patterns, and your descriptions will be drawn from Nature's bottomless well of unique patterns. Science has no use for the unique. A pattern that is unique is unreproducible and nonpredictive.

It fits into no scientific classification scheme. It cannot be used to build on. It will not help us to manipulate or to control our environments.

Therefore, when you identify a pattern in your graph, or in any other representation of your data, you must show that the pattern is not a mirage, a fleeting one-time occurrence. Either:

- repeat your experiments
- give other examples of the same pattern
- use statistical techniques to show that this particular pattern is unlikely to have occurred by chance.



## Chapter 2

# THE SCIENTIFIC PAPER

### 1. RESEARCH AND WRITING

Research winds and backtracks. Experiments go in unanticipated directions. Irregular and peculiar data pop up and threaten to derail what you thought were well-laid plans. Technical complications monopolize your attention. New questions materialize. Your ideas change, you have second-thoughts, and you question your hypotheses. This is the life of an experimental scientist.

Writing drafts of your scientific paper while you experiment helps to maintain some order in your day-to-day research. Writing keeps your efforts and ideas connected and clear: when you put your ideas into sentences, you have to face their logic, or illogic; when you sort your data into tables, you can see the holes that remain in your results; when you commit your recipes to the page, you are forced to record *all* the details; and looking at a skimpy or lopsided reference list writ large in black and white, embarrasses you into doing more background research.

The skeleton of a developing scientific paper is a blueprint. It is a guide for pulling together a coherent, useful story from the varied mix of activities that go into real world research. You will make more progress by writing as you work.

#### 1.1. Daily Lab Notebook

From the outset, organize your day-to-day research notebook or your computerized research diary with three sections:



- Materials and Methods
- Results (Data)
- References

### **1.1.1. Materials and Methods**

As you assemble your equipment, record the sources of your materials and list the instructions for your procedures in the Materials and Methods section. Write down your protocols in detail before you carry them out, see what you change when you actually do the experiments, then correct the original protocols. In addition, derive formulas and make computations directly in the Materials and Methods section of your records.

### **1.1.2. Results**

Put all your data in the Results section of your lab book or a bookkeeping computer program. Record everything—observations, impressions, times, dates, and amounts. Include even information that, at the moment, may seem irrelevant. And remember to measure things so that your Results section becomes filled with numbers: “2 home visits” “6 cm wide” “18 degrees to the left” “20 drops” “16.5 min” “3 tablets” “8 stripes” “5 repetitions” “4 pushes of the lever.”

### **1.1.3. References**

When you look something up in a paper or a book or on the Internet, immediately put the complete bibliographic information in the References section of your notebook or into a computer data file. Note where you found recipes, and record who told you bits of information.

Throughout your research project, continually chronicle the details.

## **1.2. A Beginning Draft**

Early in your research, begin to write a draft of your paper, well before your experiments are completed. Take an afternoon, go to your desk, and lay out the outlines of your paper.

Consider the writing to be an integral part of your research. As you translate your plans and records into words and as you draw diagrams and construct tables, you will see what you are doing in a clearer light. You will also gain a firmer control over your ongoing experiments.

Later, when your experiments are largely finished, you will still be writing and revising your manuscript. Inevitably, you will find holes in your notes. This is natural, it is inescapable. When you recognize that something is missing or could be done more thoroughly or accurately, take a deep breath, put down your pen, and go back to the lab. Look in more detail, repeat experiments, tie up loose ends.

As you wrestle with your manuscript, you will learn from your data and you will revise your ideas. Good research is cyclic and iterative, not linear and final. The process of writing will set things in a new light, and when it does, don't hesitate to rework your work.

## 2. WRITING THE SECTIONS OF A SCIENTIFIC PAPER

To deliver content with the least distraction, scientific papers have a stereotyped form. A paper that is laid out unusually is an effort to read because the reader must make sense of its organization and appearance before being able to absorb its content. Scientists will be disoriented by a paper that dives immediately into experimental data or that saves the background and historical context until the very end.

The stereotyped format of a scientific paper has seven parts:

- The Title and the Abstract encapsulate the paper.
- The Introduction describes where the paper's research question fits into current science.
- The Materials and Methods translates the research question into a detailed recipe of operations.
- The Results is an orderly compilation of the data observed after following the research recipe.
- The Discussion consolidates the data and connects it to the data of other researchers.
- The Conclusion gives the one or two scientific points to which the entire paper leads.
- The References lists the many links that tie the paper to the rest of science.

This is the order of the printed paper. However, this is not the best order in which to write your manuscript.

Work on the draft of your paper from the middle out, from the known to the discovered.

1. **Materials and Methods**
2. **Results**
3. **Discussion**
4. **Conclusion**
5. **Introduction**
6. **Title and Abstract**

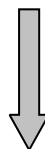

This order follows your analysis chronologically: your Materials and Methods can be thoroughly described before you have compiled your Results; your Results must be organized before you can analyze them in your Discussion; you must know your Conclusion before you can write an Introduction that sets the Conclusion in its natural place in science; and the Title and Abstract summarizing your paper must first have a completed paper to summarize.

## 2.1. Materials and Methods

### *Skeleton*

- A. Recipe no. 1
- B. Recipe no. 2
- C. ...

Begin your writing with the Materials and Methods. This is the foundation of your paper. Your observations have meaning only alongside detailed descriptions of your tools and complete instructions for your experimental procedures. The Materials and Methods section is considered so basic and so important that it is the one section reviewers will rarely ask you to trim.

Nature is complex. We are surrounded by things that can't be reproduced. For example, suppose that your hobby is flipping coins. One day you flip 20 pennies, and they all land *heads* side up.

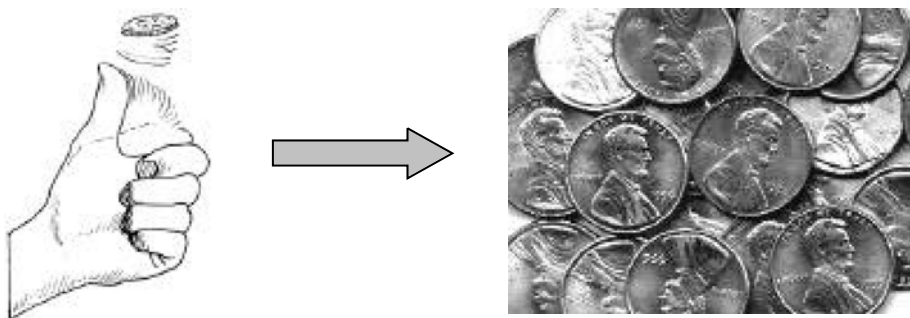

Can you report this in a scientific article?

Scientific articles record events so that others need not go through the effort of repeating them. The core of a scientific article is the guarantee: “If you follow my recipe, then you will get my results.” Every scientific article needs a trustworthy set of operational recipes—it needs an explicit Materials and Methods section. To report your coin-flipping observations in a scientific article, you must give a recipe that anyone can use to unfailingly repeat your results.

Because scientific observations come with a set of instructions attached, the Materials and Methods of your coin paper must tell us the technique for always flipping 20 *heads*. The core of any scientific paper must include a recipe that others can use to reproduce your data: it must describe exactly how to grow the same tissue-culture axon patterns that you have grown, it must give blueprints for the forge and the wire-puller that will spin the same flexible, high-conduction beryllium wire that you have spun, or it must lay out the maps that will lead us to the yeti colony that you have found.

The critical principle is:

Every observation that you record in the *Results* section of your paper must be the product of reproducible procedures that are completely detailed in the *Materials and Methods* section.



### 2.1.1. Your Daily Lab Notebook

Fill the Materials and Methods section of your lab notebook or computerized diary while you are in the midst of your experiments, when all the technical details are still fresh in your mind. List all the substances and supplies, the tools, instruments, appliances, contrivances, techniques, procedures, and solutions. Write recipes, and draw diagrams.

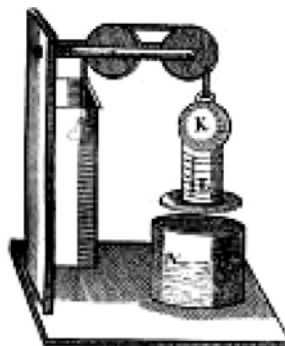
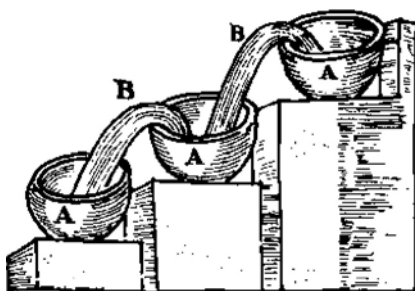

Write down every single item and operation you use, and include full details. For example:

“Used fire-polished borosilicate glass pipette. Placed single *Xenopus* embryo, pre-washed and without vitelline membrane, in autoclaved glass petri dish containing 10% Holtfreter’s solution made with double distilled tap water. Repeated 7 times.”

As you take notes, record even seemingly inconsequential things, such as:

“wore sterile gloves, used small autoclaved plastic spoon.”

Later, you will weed out unnecessary details. (Although in the end, err on the side of including too many methodological details rather than too few.)

### 2.1.2. Algorithms

The archetypal form for the descriptions in your Materials and Methods is the algorithm.

An algorithm is a machine recipe describing the steps necessary to get from Point A to Point B. Write your Materials and Methods recipes as algorithms.

In your Materials and Methods, don’t write:

“The location of the axon tip was measured accurately every 10 min.”

This sentence does not fully describe a repeatable procedure—it is not a detailed algorithm. Instead, tell us exactly what you did:

“At 10 min intervals, the videotape was stopped. The location of the axon tip was then measured (within an error of +/- 1 grid square) on a 15 cm × 15 cm transparent plastic grid of 5 squares/cm.”

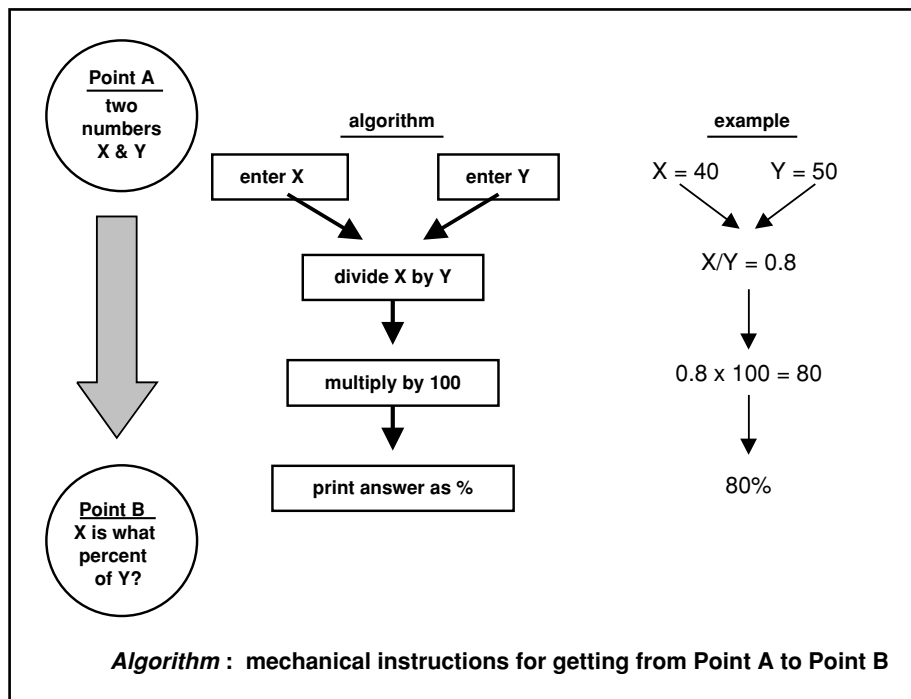

Likewise, do not write the instructionless:

“Fractal dimensions were tested for their statistical significance.”

Instead, write down the complete set of instructions that will allow other researchers to repeat your actions.

“*P* values for statistical significance were calculated from *t*-tests of the means of the logs of the fractal dimensions. (See the Appendix for a method of calculating fractal dimensions.)”

The Materials and Methods must be detailed and unambiguous. It’s helpful to imagine that you are writing a computer program in which you can give only binary (“yes/no” “on/off”) definitions and instructions. A computer cannot understand imprecise words, such as “sometimes,” “on occasion,” or “maybe.” Therefore, do not write:

“At times, it was necessary to use a Teflon-coated glass spatula.”

Even the scientific-sounding term “approximately” doesn’t belong in a Materials and Methods section, so don’t write:

“Measurements were taken at approximately 45 mph.”

Instead, write:

“Measurements were taken when the digital speedometer read 45 mph.”

or

“Measurements were taken when the dial on the speedometer read 45 mph +/- 5 mph.”

And, when you write:

“I used a Teflon-coated glass spatula.”

you must mean that you *always* used a Teflon-coated glass spatula. Otherwise, be specific. For example:

“I used a Teflon-coated glass spatula when the temperature was below 37°C.”

Also, be sure to define all your technical terms and abbreviations when they first appear, such as “Cortef (Pfizer brand hydrocortisone tablets)”

The thoroughness required for writing algorithms makes for tedious prose. Your sentences will be formulaic. A typical Materials and Methods recipe might read:

“Twelve ml of normal saline was flushed through the cannula. The cannula was allowed to drain for 1 min. Another 12 ml of normal saline was then flushed through the cannula. Immediately thereafter, 50 ml of the test solution was flushed through the cannula. The cannula was again allowed to drain for 1 min . . .”

True, this reads like a boring instruction manual, but that is exactly your goal.

### 2.1.3. Include Complete Instructions

To illustrate the detail needed in the Materials and Methods section, here are excerpts from a variety of scientific papers.

- A report on the role of *juvenile hormone* during the development of moths (Williams, 1961):

#### 2. *Excision of larval corpora allata*

Matched pairs of larvae were sacrificed and the corpora allata dissected from their heads, as previously described in the case of adult corpora allata (Williams, 1959, page 327). In certain experiments it was necessary to excise the corpora allata without killing the larval donors. By adaptations of a method suggested by Dr. William Van der Kloot (unpublished observations), a surgical approach through the underside of the neck was utilized, as follows:

A 3-cm. length of dowel was attached to a small base-board so that the dowel stood vertically above the perforated plate of the anesthesia funnel. The top end of the dowel was grooved to fit the dorsum of the larval head capsule. The larva was deeply anesthetized and placed in the anesthesia funnel so that the underside of the neck was stretched and flexed over the top end of the dowel. The head capsule was held in the groove by small clips so that the thorax and anterior abdominal segments hung vertically. In this way the blood was pressed from the neck region and the latter was flattened and essentially bloodless.

The ventral midline of the neck was lifted with forceps and a single V-shaped incision was made through the integument with microscissors. Under a

dissecting microscope the operation was carried out through the incision, first on one side of the neck and then on the other. With blunt probes the muscles of the neck were pressed apart and the corpora allata located and excised.

At the conclusion of the operation the flap of skin was spread in place. The animal was stored in a capped cardboard container at 5°C. until the next day. It was then returned to room temperature and placed on a netted branch of wild-cherry leaves.

- A report on the Kaposi's sarcoma-associated herpesvirus (KSHV) effects on infected human cells (Glaunsinger and Ganem, 2004):

*mRNA Amplification, Microarray Hybridization, and Data Analysis.* The human cDNA array has been described previously (8) and represents ~20,000 genes derived from PCR of an expressed sequence tag (EST) clone set using common primers as well as ~200 additional cDNAs amplified using gene-specific primers for KSHV sequences and select additional cellular genes. To generate mRNA for microarray analysis, 5 $\mu$ g of total RNA from each sample was subjected to linear mRNA amplification by in vitro transcription of cDNA as described previously (13). To generate each probe, 2 $\mu$ g of the amplified RNA was reverse transcribed in the presence of 300 $\mu$ M amino-allyl dUTP as described previously (14) and coupled to either Cy3 or Cy5 (Amersham Biosciences). Probes were hybridized to the microarrays overnight at 65°C. Arrays were scanned using an Axon 4000B scanner, and Cy3 and Cy5 signals were normalized such that all good features ( $r^2 \geq 0.75$ ) equaled 1. Arrays were analyzed using GenePix 3.0 and clustered using TreeView. Spots with obvious defects were excluded from the analysis. Each experiment was repeated three independent times, and genes up-regulated at least twofold greater than the reference sample in two or more of the experiments were considered significant. The fold up-regulation reported in Tables I and II represents the average fold up-regulation of that gene from the set of experiments. The complete array datasets can be viewed on the NCBI-GEO web-site ([www.ncbi.nlm.nih.gov/geo](http://www.ncbi.nlm.nih.gov/geo), accession no. GSE1406).

- A report on using high doses of cytosine arabinoside (ARA-C) to keep patients with acute myeloid leukemia in continuous complete remission: (CALBG = Cancer and Leukemia Group B, HiDAC = high dose ARA-C) (Bohm *et al.*, 2005)

## 2.2. Treatment schedules

Remission induction treatment consisted of daunorubicin (45 mg/m<sup>2</sup>/day i.v., days 1–3), etoposide (100 mg/m<sup>2</sup>/day i.v., days 1–5), and ARA-C (2 $\times$ 100 mg/m<sup>2</sup>/day i.v., days 1–7 = DAV, 3 + 5 + 7) [25]. In case of blast cell persistence, patients received a second cycle of induction chemotherapy. In most patients the second cycle consisted of ARA-C, 2  $\times$  1000 mg/m<sup>2</sup>/day, days 1–4 and mitoxantrone, 12 mg/m<sup>2</sup>/day, days 3–5 (MiDAC), whereas three patients received DAV as second induction cycle. In three patients, a third induction cycle consisting of fludarabine, 30 mg/m<sup>2</sup>/day, days 1–5 and ARA-C, 2000 mg/m<sup>2</sup>/day, days 1–5, and G-CSF, 300  $\mu$ g s.c. per day until neutrophil recovery (FLAG) was administered. Patients with blast cell persistence after three

induction cycles were excluded. Consolidation consisted of  $2 \times 3 \text{ g/m}^2/\text{day}$  ARA-C i.v. (3h-infusions in 12h-intervals) on days 1, 3, and 5 (HiDAC), with a total number of four cycles of HiDAC aimed to be administered according to the protocol described by the CALGB study group [16].

- A report measuring the interface tensions in immiscible fluid mixtures as the fluid boundaries disappear: (Sundar and Widom, 1987)

*Density Determination.* The densities of the coexisting phases in each of the three-phase mixtures were measured by pycnometry. The pycnometer used was a variation of the Ostwald-Sprengel type and is shown in Figure 3. It consisted of a flat-bottomed glass bulb of about  $20\text{-cm}^3$  volume, with two arms of sections of 1/4-in. o.d. glass tubing, each of which had incorporated in it a short section of heavy-walled precision bore capillary tubing of  $\sim 0.01\text{-in.}$  diameter. The open ends of the pycnometer limbs were sealed when needed by using 1/4-in. Swagelok end caps with Teflon ferrules. The volumes of the pycnometers up to a pair of calibration marks on the capillary arms were determined by using boiled and filtered distilled water at the temperatures of interest.

The pycnometer, once suspended in the water bath, was filled as follows. One end of a length of 1/16-in.-diameter Teflon tubing was connected to one of its limbs via a Swagelok reducing union. This Teflon tube was threaded through an aluminum tube, much of the length of which was covered with heating tape to permit the samples to be kept heated during the measurements at the higher temperatures to prevent phase separation. The other end of the Teflon tube was immersed in the phase whose density was being measured. The pycnometer was filled by applying gentle suction with a syringe with a large-bore needle attached to its other limb. After slightly overfilling, the syringe and tubing were disconnected and the contents allowed to regain thermal equilibrium. Enough liquid was then removed with a syringe so as to have the liquid levels in the capillary sections. By then measuring the heights of these levels above or below the calibration marks, the volume was accurately determined. The mass was obtained by difference and the density thus determined.

- A report on the use of proton magnetic resonance spectroscopy to assess the severity of damage in a shaken infant (Haseler *et al.*, 1997):

### **Patients**

In three infants (aged 5 months [A], 5 weeks [B], and 7 months [C]) the diagnosis of SBS was established clinically, and in particular, severe bilateral retinal hemorrhages were identified.

Infant A (5-month-old female) was admitted with apnea after a seizure that was reported initially as the result of a fall from a table (about 3 feet). However, one parent allegedly observed the other parent severely shaking the infant. There was no prior history of abuse, and no fractures were noted on skeletal survey.

Infant B (5-week-old female) was admitted within 4 hours of the injury when the mother brought the infant to the hospital after returning home to find her

behaving “abnormally” in the care of the father. Police records were strongly suggestive of shaking without blows, but there was no other history of abuse. Skeletal survey was negative and no evidence of chronic abuse was detected. A clinical examination 2 weeks postnatal was normal.

Infant C (7-month-old female) was admitted comatose after falling down three stairsteps. There was never a clear history of abuse and therefore the interval postinjury is more difficult to assign. Initially, SBS was not suspected, but on skeletal survey a fractured occipital condyl was noted. Evidence for prior injury was limited to a possible chronic subdural hematoma on MRI.

The clinical and neurological status of each infant at time of admission and on the days MRS was performed is shown in Table 1. Clinical status and outcome after long-term follow-up are also presented in Table 1.

- A report on the aging changes of Au/n-AlGa<sub>n</sub>N Schottky diodes when exposed to air (Readinger and Mohney, 2004):

Preparation of the AlGa<sub>n</sub>N surface for all processing began with a standard solvent clean (acetone, methanol, and deionized (DI) water rinse for >1 min) to remove the carbonaceous contamination layer, then blowing the samples dry with N<sub>2</sub>. The remaining portion of the contamination overlayer on GaN is presumed to exist as a surface oxide or oxynitride (24, 25). The native oxide on an AlGa<sub>n</sub>N alloy has been shown to be a mixture of Ga<sub>2</sub>O<sub>3</sub> and Al<sub>2</sub>O<sub>3</sub> (26), but the oxide is rich in Al<sub>2</sub>O<sub>3</sub> even at small Al fractions within the semiconductor (27, 28). Prior to metallization, the AlGa<sub>n</sub>N surface was treated at room temperature for 10 min in a solution of either HCl (37%) diluted 1:1 with DI water or buffered oxide etch (BOE). Following the surface treatment, the samples were rinsed in DI water and blown dry with N<sub>2</sub>. After surface preparation, the diodes were fabricated by fixing the samples beneath a shadow mask with 250 μm diameter holes and then placing them directly into the vacuum chamber for metal deposition. Following the deposition of the Schottky contacts, a sputtered or e-beam evaporated large-area Al pad was deposited over one quarter of the sample area and used as the ohmic contact.

- A report on the effects of three natural agonists on the contraction of smooth muscle in lung airways (Perez and Sanderson, 2005):

#### *Lung Slices*

To preserve the normal morphology and study the physiological response of intrapulmonary airways and blood vessels, we modified the preparation of lung slices (Bergner and Sanderson, 2002a). Male BALB/C inbred mice (Charles River Breeding Labs, Needham, MA), between 7 and 9 wk old, were killed by intraperitoneal injection of 0.3 ml of pentobarbital sodium (Nembutal) as approved by the IACUC of the University of Massachusetts Medical School. The trachea was cannulated with an intravenous (IV) catheter tube with two input ports (20G Intima; Becton Dickinson) and secured with suture thread (Dexon II, 4-0; Davis and Geck) to ensure a good seal. A syringe filled with 3 ml of air was attached to one port

while the other port was closed. The chest cavity was opened by cutting along the sternum and the ribs adjacent to the diaphragm. To reduce the intrapulmonary blood vessel resistance and facilitate vessel perfusion with gelatin, the collapsed lungs were gently reinflated to approximate their total lung capacity by injecting ~1.5 ml of air. A warm (37°C) solution of gelatin (type A, porcine skin, 300 bloom, 6% in sHBSS) was perfused through the intrapulmonary blood vessels, via the pulmonary artery, by inserting the hypodermic needle of an infusion set (SV × S25BL; Terumo Corporation) into the right ventricle of the heart and slowly injecting ~1 ml of gelatin solution. A small cotton–wool swab soaked in ice-cold sHBSS was placed only on the heart to solidify the gelatin before the perfusion needle was removed. The lungs were deflated by releasing the positive air pressure. A syringe filled with a warm (37°C) solution of 2% agarose (type VII or VII-A: low gelling temperature) in sHBSS was attached to the second port of the catheter. The IV tube was clamped proximal to the trachea and purged of air with the agarose solution by allowing the trapped air to escape via a 27G needle inserted into the IV tube proximal to the clamp. The IV clamp was removed and the lungs were reinflated by injecting ~1.3 ml of agarose-sHBSS. Subsequently, ~0.2 ml of air was injected into the airways to flush the agarose-sHBSS out of the airways and into the distal alveolar space. Immediately after agarose inflation, the lungs were washed with ice-cold sHBSS, and the animal was placed at 4°C for 15 min. The lung and heart were removed and placed in sHBSS (4°C) and cooled for an additional 30 min to ensure the complete gelling of the gelatin and agarose.

#### 2.1.4. Statistics

If your experiments produce numerical data, you will undoubtedly describe the data statistically. The Materials and Methods should explain the statistical methods you have used. In your *Statistical Methods* subsection, include citations of your exact sources—statistical books, technical papers, and computer programs. Moreover, when your experiments have been built using a preplanned statistical design, this is the place to explain the details.

As examples, here are the *Statistical Methods* subsections from three papers.

- A report examining the ultrasound echogenicity of the substantia nigra in Parkinson's disease: (PD = Parkinson's disease, SN = substantia nigra) (Berg *et al.*, 2001)

##### Statistics

Descriptive statistics are given as median with lower and upper quartiles (25th and 75th percentile respectively). Results of SN echogenicity of PD patients were compared with measurements of hyperechogenic areas at the SN of 30 age matched controls examined by the same sonographer with the same ultrasound system [3]. The upper standard deviation of SN echogenicity in the controls group was used as the cut-off for further analyses. Intergroup comparison was performed by the Mann-Whitney U-Test. Correlation analysis was performed by Spearman rank correlation.

- A report on using the tri-block polymer P188 6 hr after a spinal cord injury in a mammal to increase the function and heal the structure of the spinal cord (Borgens *et al.*, 2004):

### **Statistical Evaluation**

Statistical computations were carried out using InStat software (GraphPad, San Diego, CA). Comparison of the proportions of animals in each group tested for evoked potentials was carried out using Fisher's exact test (two-tailed) and a comparison of means with Mann-Whitney nonparametric two-tailed test. Normalized measurements from 3D reconstructions of control and experimental groups were compared using unpaired, two-tailed, Student's t-test.

- A report examining the effect of matrix metalloproteinase inhibitors on healing after periodontal surgery: (AFS = access flap surgery, BOP = bleeding on probing, CAL = clinical attachment levels, LDD = low dose doxycycline, PD = probing depth) (Gapski *et al.*, 2004)

### **Statistical Analyses**

Data available for each patient were subjected to an intent-to-treat analysis and included full-mouth clinical measurements for three different parameters (PD, CAL, and BOP) examined at six sites per tooth. Sample size determination for this pilot study was determined from Golub *et al.*, (8) using 80% power for differences expected in a primary biological outcome measure, the bone resorption marker, ICTP. The level and prevalence of 40 species and ICTP levels (pg/site) was measured from the surgically-treated quadrant excluding third molars. Clinical, microbial, and ICTP data were averaged within a patient and then compared between groups. In other analyses, data were stratified according to baseline PD of 1 to 4, 5 to 6, and  $\geq 7$  mm and averaged in a patient and then across the study population for clinical parameters and ICTP levels. Differences between drug and placebo groups were performed using the Mann-Whitney test. Differences with a *P* value less than 0.05 were considered significant. Microbiologic data were analyzed separately for sites receiving AFS+LDD and AFS+placebo. Mean levels (counts $\times 10^5$ ) for each of 40 species were computed for each patient in each treatment category at each visit. Significant differences over time were determined separately for each treatment category using the Quade test and the differences between groups were determined by the Mann-Whitney test. All analyses were performed using the patient as the unit of analysis.

## **2.1.5. An Organized Instruction Manual**

The Materials and Methods is the instruction manual for everything you do in your research project. Give your instruction manual an internal organization that is easy to understand.

First, group the instructions together into units that are complete recipes. Give them clear, explanatory titles, such as:

*Anesthetizing the Fruit Flies*  
*Building the Electrodes*



*Calculating the Surface Areas*  
*Calibrating the Oscilloscope*  
*Fitting Caliper Bars to Subjects*  
*Interpreting the Chromatographic Scans*  
*Measuring the pH of the Initial Samples*  
*Normalizing the Tonal Response*  
*Preparing the Staining Solutions*  
*Recruiting the Volunteers*  
*The Steps in the Transplant Surgery*  
*Statistical Methods*

Next, organize the recipes so that readers can quickly find whichever set of instructions they are looking for. Often, the Materials and Methods recipes are presented chronologically, in the order that they are done during the experiment. You may, however, feel that it is clearer to group them some other way. For instance, you may put the chemical recipes together, or you may put all the procedures dealing with experimental subjects together. Pick an organization that makes your instruction manual easy to navigate.

### **2.1.6. Example of a Complete Materials and Methods Section**

#### Materials and Methods

Neurons were stained in histologic sections of tadpoles and in tissue culture preparations of frog and chick embryonic cells.

Xenopus tadpoles were raised from laboratory colonies. Primary amphibian tissue cultures 24–48 h old were grown by disaggregating neural tube cells of tailbud stage *Xenopus* embryos and plating the cells on glass coverslips in a modified Niu-Twitty solution (Hamburger 1960) with 2% fetal bovine serum, nerve growth factor (NGF), and antibiotics added (adapted from Spitzer and Lamborghini 1976).

Primary avian tissue cultures 24–48 h old were grown by disaggregating dorsal root ganglion cells of 7–12 d chick embryos and plating the cells on glass coverslips in Leibovitz's (L-15) medium (GIBCO) with 10% fetal bovine serum, 0.6% glucose, 0.3% methyl cellulose, NGF, antibiotics, and cytosine arabinoside. (Further details can be found in Shaw and Bray 1977.)

#### *Histologic preparation*

- a) Tadpole sections—Whole tadpoles (*Xenopus* stage 48—Nieuwkoop and Faber 1967) were fixed by immersion for 45 min in an ethanol fixative (90 ml 80% ethanol, 5 ml formalin, 5 ml glacial acetic acid, 0.035 g NaCl, 1 ml DMSO). The tissues were then washed, embedded in paraffin, and sectioned at 12  $\mu\text{m}$ . Slides were deparaffinized and hydrated to glass-distilled water.
- b) Cultures—Cell cultures were fixed by flooding them with the same ethanol fixative. The first fixative bath was immediately replaced with fresh fixative, and, in this, the cells (on glass coverslips) were allowed to continue fixing for 45 min. Finally, the coverslips were rinsed ten times in tap water.

### Staining

a) *Bodian stain*—Slide and coverslip preparations were stained according to the following schedule:

1. Immerse in solution A for 24 h at 37°C.
2. Rinse well and soak in solution B for 10 min.
3. Rinse well and soak in solution C for 1 min.
4. Rinse well and soak in solution D for 3 min.
5. Rinse well and soak in solution E for 7 min.

Rinses were in three changes of glass-distilled water. Steps 2–5 were done at room temperature.

Bodian Solutions: (each made in 100 ml glass-distilled water)

A - 1 g silver protein (Roboz Surgical Inst Co)

5 g copper foil

B - 0.5 g potassium metaborate

1 g hydroquinone

5 g anhydrous sodium sulfite

C - 1 drop glacial acetic acid

1 g gold chloride

D - 1 g oxalic acid

E - 5 g sodium thiosulfate

b) *Post-staining intensification*—After the initial staining, slides and coverslips were soaked in intensifier solution J for 1 min, again in solution C for 1 min (for thick sections) or 10 min (for fixed cultures), then dehydrated and mounted with Permount.

Recipe for intensifier solution J:

Add solution F to solution G. Stir thoroughly until no more precipitate forms. Add solution H. Stir until no more precipitate dissolves. Add solution I and stir well. Filter through Millex-GS 0.22 um filter unit (Millipore Corp) to remove remaining precipitate.

Intensifier Solutions:

F - 1.5 g silver nitrate

25 ml glass-distilled water

G - 1.5 g sodium sulfite

25 ml glass-distilled water

H - 2.6 g sodium thiosulfate

25 ml glass-distilled water

I - 0.4 g sodium sulfite

0.6 g Elon (Eastman Kodak)

75 ml glass-distilled water

[This intensification method is a variant of a standard photographic enhancement procedure. See Hodgman *et al.*, 1960.]

### 2.1.7. Key Variables

Your Materials and Methods section should be comprehensive. It is an instruction manual for *all* the things you have done to produce well-defined data. The other parts of your paper, however, will focus on only two or three aspects of that data. After writing a draft of your Materials and Methods section, it's time to explicitly center your paper around its key variables.

For example, suppose that you are evaluating the heights of two-year-old girls whose mothers have IQ's of over 130. The focus of your paper will be just two key variables: the IQ of a mother and the height of her two-year old daughter. A thorough Materials and Methods for this study might include recipes for:

*Finding high-IQ mothers of two-year old girls*

*Enlisting mothers in the study*

*Verifying IQ scores*

*Verifying children's ages*

*Measuring children's heights*

*Statistical methods*

The Materials and Methods will give complete instructions for all of these operations. From this comprehensive instruction manual, it may not be immediately apparent that the focus of your paper will be just two specific items: the IQ of a mother and the height of her two-year old daughter.

A scientific paper can focus on only a few of the many bits of information and intriguing byways that you have seen during your project. Make this clear to yourself early in your writing. After drafting a comprehensive Materials and Methods, explicitly limit your manuscript. Define the focal variables of your scientific report.

Therefore, before you go any farther, list those few variables that you will be studying. Label them your "*key variables*." To keep you on track, write the *key variables* at the head of the drafts of the Results, Discussion, Title, and Abstract sections of your paper.

Now that you have committed your paper to its specific, focal theme, you can dive into your Results.

## 2.2. Appendix

### *Skeleton*

- A. Title
- B. Long Recipe
- C. References

An Appendix is a self-contained addition to the Materials and Methods.

In a scientific paper, the Appendix is not a commentary, it is a detailed explanation that is too long for the Materials and Methods section. An Appendix might contain a long recipe for a chemical preparation. It might explain a mathematical formula, detail a computer program, or diagram the wiring of an apparatus.

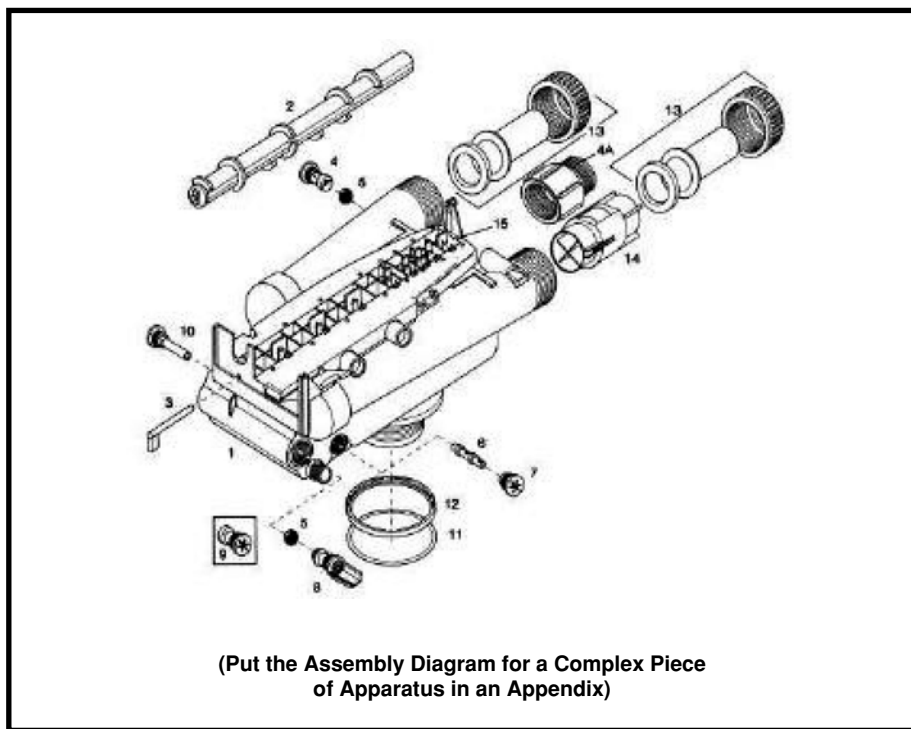

It might illustrate a surgical operation used in your experiments. It might reproduce the complete survey form used in collecting data.

Appendices are lettered, and they appear after the References section of your paper. An Appendix has a title and is a stand-alone entity. If it includes bibliographic citations, those citations are listed at the end of the Appendix, not in the References section of the main paper.

*Example:*

## APPENDIX A

### Calculating the Fractal Dimension of the Growth Path of an Axon

Topologically, a curve in a plane always has a dimension of 1. Nevertheless, as it becomes more and more convoluted, a curve fills more and more of the plane. From this perspective, a convoluted curve might be considered to have a fractional geometric or non-topological dimension—a “fractal dimension”—of greater than 1 (Mandelbrot 1977 1983). In terms of fractals, a straight line has a dimension of 1, an irregular line has a dimension of between 1 and 2, and a line that is so convoluted as to completely fill a plane has a dimension approaching the dimension of the plane, namely a dimension of 2. In this way, fractal dimensions assign numbers to the degree of convolution of planar curves.

The general form of a fractal dimension  $D$  of a planar curve is:

$$(\text{length})^{1/D} = K(\text{area})^{1/2}$$

where ‘length’ signifies the total geometric length of the curve, ‘area’ is the maximum potential geometric area that the curve could fill, and ‘ $K$ ’ is a constant (Mandelbrot 1977 1983). For planar curves that are constructed of connected line segments, a practical form of this equation is:

$$D = \log(n) / \log(nd/L) = \log(n) / (\log(n) + \log(d/L))$$

where ‘ $d$ ’ is the planar diameter of the curve (here estimated as the greatest distance between any two line segment endpoints along the curve), and ‘ $L$ ’ is the total geometric length of the curve (the sum of the lengths of all the line segments). This formula has the following limiting values:

- a. When the curve is a straight line,  $L$  is equal to the planar diameter of the curve, and the fractal dimension is  $D = 1$ .
- b. When the curve is a long random walk,  $L$  will be approximately equal to  $(n^{1/2})L$ , and the fractal dimension will have  $D$  approaching 2.

(Further details can be found in Katz and George 1985.)

Katz MJ, George EB. 1985. Fractals and the analysis of growth paths. *Bull Math Biol* 47: 273–286.

Mandelbrot BB. 1977. *Fractals: Form, Chance, and Dimension*. WH Freeman, NY.

Mandelbrot BB. 1983. *The Fractal Geometry of Nature*. WH Freeman, NY.

## 2.3. Results

### *Skeleton*

- A. General Observations
- B. Specific Observations
- C. Case Studies
  - a. Best Cases and/or
  - b. Representative Cases

### 2.3.1. Along with the Recipes in the *Materials And Methods*, the *Results* Are the Enduring Parts of a Scientific Paper

When on the run, scientists read the Title and the Abstract for a quick taste of a scientific article. With more time, they also skim the Introduction, glance at the pictures, and read the Conclusion. To *study* the article, they will note the Results and will read through the Introduction and the Discussion. We all read the scientific literature this way, and we grow up feeling that the gold of a scientific article is in its ends.

In reality, however, while the ends may have the gleam, the middle has the enduring substance. The glitter that is in Discussion sections is especially ephemeral, because it is in the Discussion that data is tied to scientific theories, hypotheses, and conjectures. These scientific generalities are under constant renovation. They come, they're tuned and tweaked, and they go.

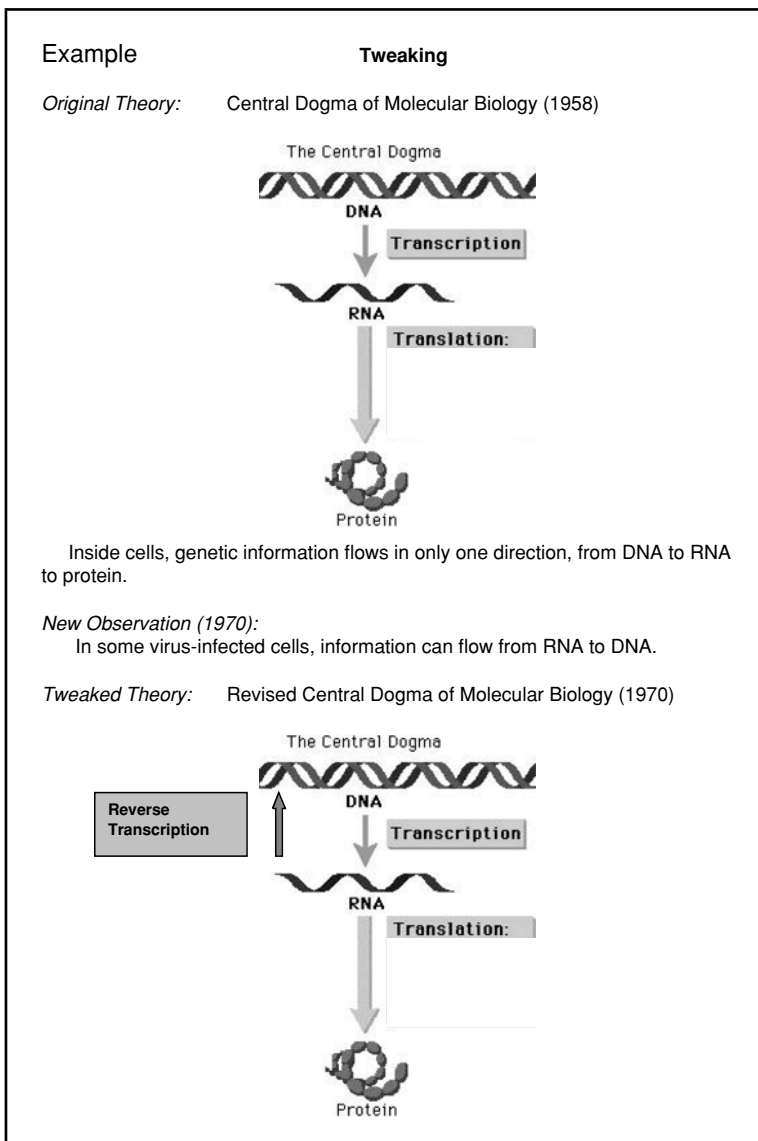

The flashes and gleams of a scientific article can be transitory. The data reported in the article usually last much longer. Carefully-made scientific observations endure: we can still use data in scientific articles more than a century old. The strongest part of a scientific article is the *recipe* → *results* report at its center. It is here that the scientist tells his or her readers: “This is what you, too, will find if you follow my recipe.” The Materials and Methods section gives the recipe, and the Results section tells what will happen if someone follows that recipe.

### 2.3.2. Key Variables

The Results are what you observed. As you do your experiments, be an immediate and complete chronicler. Write everything in your lab notebook or computerized research diary.

Record things as they happen, without trying to impose order or logic. Look at the focal point of the experiment, but look also at the edges. Write down the things that you planned to study, and then note everything else that happens. And, whenever possible, write down numbers—time things, count things, and measure things.

11 g                      34 s  
**3,000 cpm**    16.3 mg        1.5 flashes  
 7 sets                    106 m                3.45662 kg  
 0.441 psi

When you sit down to write your paper, however, limit your final data to those things produced by the recipes in your Materials and Methods. The observations in your Results are scientific only when accompanied by the full recipes for repeating them. Do not include tidbits in your Results, no matter how intriguing, and leave out preliminary results. (For example, don't write: "In preliminary experiments, we found that the same stain intensification procedure worked well for fixed sections of fetal human nervous system.")

To help you limit your Results to legitimate data, you listed your *key variables*—the two or three variables that were the focus of your research—when you wrote the draft of your Materials and Methods section. These were variables that you observed and recorded using procedures completely detailed in your Materials and Methods. Make the *key variables* the center of the Results section of your paper.

### 2.3.3. The Simplest, Most Inclusive Pattern

The Results section presents your data with organization but without interpretation.

When you have masses of data, it takes some effort to organize this data for your reader. As you arrange your observations, don't try to prove a specific hypothesis. Undoubtedly, you began your research with an idea of what to expect. Set this idea aside. Instead, let your data lead you.

Take your records of the *key variables* and spread them on your desk. Suppose you are studying the number of stripes found on tarantulas. From your notebook, your records of tarantula (male and female *Brachypelma sabulosum* and *Brachypelma angustum*) observations might be:



<u>Day 1</u>	<u>Day 2</u>	<u>Day 3</u>
7 cm <i>B. sabulosum</i> female, 8 stripes	5 cm <i>B. sabulosum</i> female, 8 stripes	12 cm <i>B. sabulosum</i> male, 8 stripes
15 cm <i>B. sabulosum</i> female, 9 stripes	13 cm <i>B. sabulosum</i> female, 9 stripes	10 cm <i>B. angustum</i> male, 6 stripes
14 cm <i>B. sabulosum</i> male, 9 stripes	17 cm <i>B. sabulosum</i> female, 7 stripes	11 cm <i>B. sabulosum</i> female, 8 stripes
7 cm <i>B. angustum</i> male, 7 stripes	9 cm <i>B. sabulosum</i> male, 8 stripes	12 cm <i>B. sabulosum</i> female, 6 stripes

Now arrange and rearrange the observations in all possible combinations, looking for inherent patterns.

- Look at each *key variable* alone.
- Set variable against variable.
- Put the data in chronological order.
- Order the data by size, weight, gender, shape, color, or height.
- Try histograms and other graphs.

Shuffling your tarantula data around your desk, you would try these arrangements:

<u><i>Brachypelma sabulosum</i></u>	14 cm male 9 stripes
12 cm female 6 stripes	15 cm female 9 stripes
17 cm female 7 stripes	
5 cm female 8 stripes	<u><i>Brachypelma angustum</i></u>
7 cm female 8 stripes	10 cm male 6 stripes
9 cm male 8 stripes	7 cm male 7 stripes
11 cm female 8 stripes	
12 cm male 8 stripes	
13 cm female 9 stripes	

<u>female</u>	<u>male</u>
12 cm 6 stripes	10 cm 6 stripes
17 cm 7 stripes	7 cm 7 stripes
5 cm 8 stripes	9 cm 8 stripes
7cm 8 stripes	12 cm 8 stripes
11 cm 8 stripes	14 cm 9 stripes
13 cm 9 stripes	
15 cm 9 stripes	

5 cm 8 stripes  
 7 cm 7 stripes  
 7 cm 8 stripes  
 9 cm 8 stripes  
 10 cm 6 stripes  
 11 cm 8 stripes  
 12 cm 6 stripes  
 12 cm 8 stripes  
 13 cm 9 stripes  
 14 cm 9 stripes  
 15 cm 9 stripes  
 17 cm 7 stripes

6 stripes {10 cm}  
 7 stripes {7 cm, 17 cm}  
 8 stripes {5 cm, 7 cm, 9 cm, 11 cm, 12 cm}  
 9 stripes {13 cm, 14 cm, 15 cm}

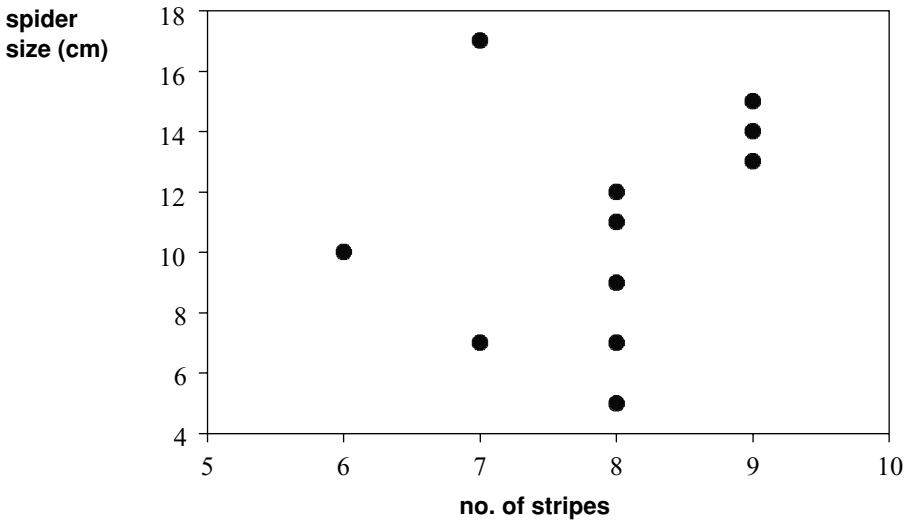
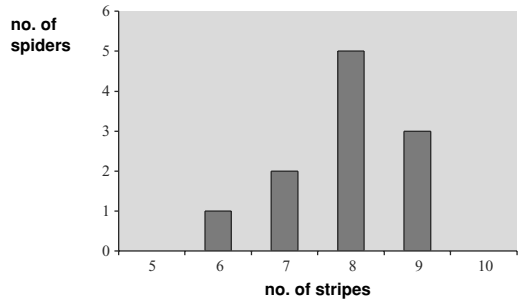

In each of your arrangements, look for patterns. For the presentation in your paper, choose one of the simpler patterns.

Often, there is no one “right” arrangement for your data, but there are better and worse arrangements. The better arrangements form fairly neat, concise patterns—patterns that include most of the data with the least squeezing, stretching, or trimming. For our spider example, this histogram is one of the better ways to present the data:

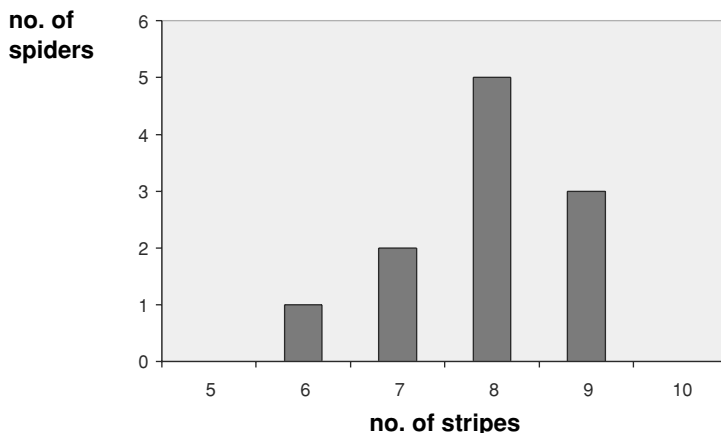

This is a concise, inclusive, and simple organization of our observations. Moreover, it is a spatial organization, and therefore, it has the benefit of allowing readers to use their visual systems to discern patterns.

### 2.3.4. Enhancing the Pattern

Now stand back and look over your data pattern with a critical eye.

- Are there gaps?
- Would additional examples give you more confidence in a trend?

If you answer “yes,” return to your experiments. Research is iterative. Your data set is not immutable, and it is never absolutely complete, so go back and collect more data.

### 2.3.5. Three Subsections

After organizing your data in figures, tables, or graphs, start composing the text of your Results.

#### 2.3.5.1. General Observations

When you write the Results, don’t rush to the heart of your data. Offer your reader a brief overview of your experiments in a General Observations subsection.

Some useful things to include here are:

- A description of what would happen if you had made no experimental manipulations or intrusions. This subsection might begin: “Without intervention, . . .” “The control situation . . .” “In the natural setting, . . .”
- A description of the experimental setting. Specifically, tell how things looked just before you began collecting data. This subsection might begin: “At the outset of the experiment, . . .”
- A description using a zoom lens, beginning with a wide-angle view. This subsection might begin: “The first things visible on opening the embryonic sac

were . . .” “The answer sheets fell into two broad categories . . .” “All the control gels were stained either blue or red, and all the experimental gels had only yellow, yellow-green, or green bands.”

Here are good examples of General Observation subsections excerpted from the Results of a variety of papers.

- A report on the role of *juvenile hormone* during the development of moths (Williams, 1961):

When a living, active corpus allatum is implanted into a test pupa, the gland survives and becomes the site of synthesis and secretion of juvenile hormone. If several active glands are implanted, a corresponding number of synthetic centers are established. . . .

. . . Four (two pairs) adult corpora allata were implanted into abdomens of 24 test pupae; a second group of 24 pupae received only a single implant (one-half pair). The hosts were then placed at 25°C to await the onset of development.

Three to four weeks later, a spectacular difference was evident between the two groups of animals. The individuals that received the four implants showed a generalized inhibition of adult differentiation, as signaled by the formation of a new pupal cuticle throughout broad areas of head, thorax, and abdomen. Indeed some of these animals could properly be described as second pupal stages in which only traces of adult characteristics had been differentiated. By contrast, the pupae that had received only a single corpus allatum ordinarily developed into adult moths and showed few abnormalities except for the formation of a new pupal cuticle along the plastic window where the pupal integument had been excised in the implantation procedure.

- A report of growth of individual axons and accompanying sheath cells followed in the living animal over periods of days to weeks (Speidel, 1932):

*I. The normal distribution of nerves in the tail fin and the early changes*

The central portion of the tail of the tadpole is occupied by the spinal cord, axial skeleton (notochord), and the muscle mass. This region is not suitable for observation in the living animal. Emerging from between the muscle masses may be seen the nerves that supply the fin expansion. In general, these are segmentally arranged. Near the ventral and dorsal edges of the muscle mass longitudinal nerves may sometimes be seen which serve to connect adjacent spinal nerves with each other. Peripheral anastomoses between adjacent nerves also occur frequently. There is a set of nerves for the left side and a corresponding set for the right side. In the dorsal fin of older tadpoles halfway between the muscle mass and the fin edge extends a rather large longitudinal nerve, the dorsal branch of the ramus lateralis vagi.

- A report consolidating evidence of the speed of extinction of North American dinosaurs (Fastovsky and Sheehan, 2005):

In the latest Cretaceous of the North American Western Interior, dinosaurs such as *Triceratops*, *Tyrannosaurus*, and *Edmontosaurus* (and a host of lesser luminaries) roamed upland and coastal plain settings (Lehman, 1987) that formed during the Laramide phase of the Rocky Mountain uplift (Peterson, 1986). Dinosaur-bearing

units that have been the subjects of studies sufficiently detailed to resolve the nature of the extinction are preserved in the structurally complicated Hanna Basin, an intermontane basin in southern Wyoming (Eberle and Lillegraven, 1998; Lillegraven *et al.*, 2004), and undeformed sediments of the Williston Basin, an intracratonic basin extending through eastern Montana and western North and South Dakota (Peterson, 1986) (Fig. 1).

- A report on using high doses of cytosine arabinoside (ARA-C) to keep patients with acute myeloid leukemia (AML) in continuous complete remission (CCR) (Bohm *et al.*, 2005):

### *3.1. Outcome of induction chemotherapy*

Seventy-three patients with de novo AML received induction treatment with DAV. Complete remission (CR) was obtained in 54/73 patients (74%). The majority of these patients (36/54 = 66.7%) entered CR after the first induction cycle, whereas in 18/54 patients (33.3%), more than one induction chemotherapy cycle (two cycles,  $n = 15$ ; three cycles,  $n = 3$ ) was required to achieve a CR. In 19 patients (26%), no CR could be obtained. In this group, 16 patients had a blast cell persistence, and three patients died from treatment-related complications within 28 days after start of therapy (induction-related death).

- A report on the effects of three natural agonists on the contraction of smooth muscle in lung airways: (SMC = smooth muscle cell) (Perez and Sanderson, 2005)

### *Characteristics and Morphology of Lung Slices*

Throughout the lungs, the intrapulmonary airways and arteries have a close anatomical association that follows a parallel course. As a result, an airway and an accompanying arteriole (a bronchiole–arteriole pair) was easily identified and visualized in a single microscopic field of view (Fig. 1, A and B). This also makes the identification of pulmonary veins (not shown) easier because they are found as individual structures at some distance away from the bronchiole–arteriole pair. This anatomical separation precludes a direct comparison of the arteriole and vein responses in the same experiment. Each bronchiole–arteriole pair, when observed in transverse section, usually consists of a larger airway and a smaller arteriole. The airway is characterized by a lining of cuboidal epithelial cells with actively beating cilia. The arteriole lumen is lined with a low profile, squamous endothelium. Both structures are surrounded by a dense layer of tissue that often has a fibrous appearance. More distally, the airway and arteriole are surrounded by the alveolar parenchyma consisting of thin-walled sacs (Fig. 1, A and B). Specific antibody staining for SMC  $\alpha$ -actin (Fig. 1 A) reveals that the SMCs are located in the surrounding fibrous layer, directly below the epithelium or endothelium. It is important to note that in the lung slices used, only the alveoli remain filled with agarose. Before gelling, the agarose is flushed out of the airways with air. The gelatin is absent from the arterioles because it dissolves during incubation at 37°C. Consequently, the luminal compartments do not offer resistance to contraction. Agarose does not dissolve at 37°C but remains in the alveoli to keep the alveoli inflated and airways open.

Full example of a *General Observations* subsection:

The normal Bodian stain recipe (listed in the Materials and Methods) works well on young amphibian tadpoles. As reported in the standard literature (e.g. Luna 1960, Lillie 1965), the Bodian stain highlights the cytoskeleton of neurons. In stained sections, mature axons and striated muscle appear black, while cell nuclei are dull brown or purple. The Bodian stain also enhances melanin pigment granules. In the embryonic central nervous system, the marginal zone remains unstained except for the locations of those few axons sufficiently mature to contain many neurofilaments. In Bodian-stained sections, the few large, early-maturing axons can be followed individually. An example is shown in Figure 1a.

### 2.3.5.2. Specific Observations

Next, present the heart of your research. Report the *key variables* for each of your observations.

2.3.5.2.1. *Narrative Descriptions and Pictures*: Begin with those key variables that cannot be easily quantified.

Describe, for instance, the structural, textural, shape, or color details of your observations. Tell how these variables changed during the experiments. Look for patterns in the changes, and point them out to your reader. This is the part of the text that usually refers the reader to accompanying photographs, illustrations, and diagrams.



***Brachypelma sabulosum***

Here are two examples of nonnumerical Results, illustrating the thoroughness of a good narrative scientific description.

- A report on using the tri-block polymer P188 6 hr after a spinal cord injury in a mammal to increase the function and heal the structure of the spinal cord (Borgens *et al.*, 2004):

### **Comparative Study of Outcomes: 3D Anatomic Studies**

Due to the severity of the crush injury, injured segments of spinal cord were compressed and stenotic (Fig. 5i). For every 3D reconstruction, the injury site was centrally located at the region where the spinal cord was most compressed during registration of the images. The bilateral indentation of the crush injury was evident in many of the 3D reconstructions (Fig. 5Bi). Typically, after a constant displacement injury a hemorrhagic lesion is produced, causing profound destruction of the central gray matter of the spinal cord and variable sparing of the circumferential white matter (Moriarty *et al.*, 1998; Tuszynskietal., 1999; Duerstock and Borgens, 2002). The 3D reconstruction processes both imaged and quantified regions of destroyed gray matter, marginal areas of spared gray and white matter, and cysts. Figure 5A and 5B include insets of histologic sections from the lesion epicenter of vehicle-treated and P188-treated reconstructed spinal cord segments, respectively. These histologic photomicrographs show thin tracts of spared silver impregnated axons of the white matter, whereas more central columns and most gray matter were destroyed. The images (ii) in Figure 5 show regions of apparently normal parenchyma in control (vehicle-treated) and P188-treated spinal cords. This intact parenchyma in control segments was located mainly in the subpial region and was virtually nonexistent at the lesion epicenter (Fig. 5Bii, Dii). Normal appearing parenchyma (both gray and white) was more abundant in P188-treated spinal segments than in control spinal cords (Fig. 5Aii, Cii). The amount of cavitation in these cords was the simplest pathologic feature to discriminate between the groups (Fig. 6). In the P188-treated spinal cord segments, cysts were smaller and dispersed more variably on either side of the central lesion (Fig. 6A, C). In the vehicle-treated spinal cords, cysts were larger and more localized within the spinal cord segment (Fig. 5, insets; Fig. 6B, D). Often cavitation was not confined within the field of view, extending beyond that particular segment of spinal cord (Fig. 5i). The area of scarification, devoid of silver impregnated nerve fibers, was located centrally at the region where the spinal cord was most compressed. In the vehicle-treated spinal cords, the lesion appeared less focal than in PEG-treated cords and tended to surround the cysts (Fig. 5, insets).

- A report describing the movements of neighboring cells in tissue culture (Abercrombie and Heaysman, 1954):

The following is a brief qualitative description, based mainly on examination of films, of what happens between the two confronted explants in what we shall term the inter-explant area. The two sheets of cells, in a constantly changing irregular two-dimensional meshwork, looser in density at the periphery than centrally, advance towards each other, narrowing down the empty space between. Isolated cells may cross over from one sheet to the other. Contact is then established here and there between the peripheral cells of the two sheets and steadily becomes more general as the loose texture of each periphery is gradually lost, the intercellular spaces

becoming smaller. So far there is no noticeable diminution of the growth trend of the two sheets outward from their respective explants. But as the open spaces fill, concerted movement becomes more localised, except at the lateral margins of the inter-explant area, i.e., the sides not bordered by the explants. There some of the cells take part in a new trend towards the lateral unoccupied space. As the intercellular spaces become reduced to sizes considerably smaller than the area of a single cell, general trends of movement cease to be detectable, except laterally. The cells maintain only an uncoordinated oscillation. The continuous sheet of cells which now covers the inter-explant area is still largely a “monolayer,” though with some overlapping of cell processes and here and there of entire cells.

And here is a good example of a qualitative, nonnumerical description that is based on numerical data.

- A report on the effects of three natural agonists on the contraction of smooth muscle in lung airways: (ACH = acetylcholine, SMC = smooth muscle cell) (Perez and Sanderson, 2005)

To investigate the cause of the slow relaxation of the airway observed during the stimulation with ACH in the continued presence of  $\text{Ni}^{2+}$ , we simultaneously measured the changes in SMC  $[\text{Ca}^{2+}]_i$  and contraction of the airway (Fig. 9C). After the initial increase in  $[\text{Ca}^{2+}]_i$  and the onset of  $\text{Ca}^{2+}$  oscillations, the frequency of  $\text{Ca}^{2+}$  oscillations progressively decreased and this was accompanied by the relaxation of the airway. After removal of  $\text{Ni}^{2+}$ , but still in the presence of ACH, the frequency of the  $\text{Ca}^{2+}$  oscillations increased again and the airway recontracted. These results suggest that the Ni blocked  $\text{Ca}^{2+}$  channels that contribute to the maintenance of the  $\text{Ca}^{2+}$  oscillations and perhaps serve to refill internal  $\text{Ca}^{2+}$  stores.

2.3.5.2.2. *Numerical Data:* Next, describe those *key variables* that you have quantified.

2.3.5.2.2.1. If your experimental plan produces only a few data points, you can simply list the *key variables* for each of those data points:

“We found only two tarantulas of the species *Brachypelma angustum*. These were: a 7 cm long male with 7 dorsal stripes, and a 10 cm male with 6 dorsal stripes.”

- For example, here is an excerpt from a report on the growth of individual axons and accompanying sheath cells followed in the living animal over periods of days to weeks. This study produced only a few numbers from very long experiments (Speidel, 1932).

### III. *Rate of primitive sheath-cell migration*

... Attempts were made to stimulate sheath cells to their maximum migratory possibilities by tail section and regeneration. Rapid movement was observed six days after the operation. Measurements showed that the more active cells in the



newly regenerated zone sometimes moved more than 200u during a twenty-four-hour period. Many instances have been recorded of movement of from 100u to 200u. As yet, no case has been observed in which the movement exceeded 230u.

2.3.5.2.2.2. On the other hand, if you have many data points, consolidate your data into natural groupings and use tables or graphs. (Chapter 1, sections 3 and 4, above, discuss how to build tables and simple graphs.) Put a self-explanatory legend on each table and graph. Then refer to each table or graph in the text with a brief summary; for example:

“Twelve tarantulas of the genus *Brachypelma* were photographed on days 1-3 of the expedition. Graph 1 shows the numbers of spiders with 6, 7, 8, or 9 stripes . . .”

Look for patterns in the numbers, and point them out to your reader in the text:

“In our sample of 12 spiders, most had 8 stripes.”

Here are good examples of simple, clear tables from the Results sections of:

- a report on the role of *juvenile hormone* during the development of moths (reconstructed from Williams, 1961).

**TABLE III**

*Effects of removal of corpora allata from fifth instar Cecropia larvae*

State at time of operation	No. of animals	Results	
		Normal pupa	Pupal-adult
Young 5th instar	3	0	3
Mid 5th instar	9	5	4
Late 5th instar	5	2	3
Spinning	13	12	1

- a report on the relatively low number of studies on motor control in the psychological literature (reconstructed from Rosenbaum, 2005).

**TABLE 1**

Citations of selected topics in the social science citation index from 1986 to 2004

Topic	Occurrence
Attention	51,946
Cognition	65,039
Decision or judgment or reasoning	54,367
Language	42,205
Memory	48,867
Motor	17,424
Perception or pattern recognition	34,328

Note: All topics except for Motor are referred to in Ashcroft’s (2002) *Cognitive Psychology* (3rd ed.; see Appendix B).

- a report on using the tri-block polymer P188 6 hr after a spinal cord injury in a mammal to increase the function and heal the structure of the spinal cord (reconstructed from Borgens *et al.*, 2004).

**TABLE I. Cutaneous trunci muscle response to P188**

Group	<i>n</i>	% Loss (a)	<i>P</i> (b)	Recovered n(c)	<i>P</i> (b)	% Recovered (d)
P188	11	47.0 ± 2.6	0.13	5	0.03	40.8 ± 5.3
Control	10	41.3 ± 3.3		0		

(a) The percentage of the total cutaneous trunci muscle (CTM) receptive field that was lost after spinal injury (mean ± SE).

(b) Statistical difference between the two groups compared with Fisher's exact test, two-tailed.

(c) The number of animals that recovered any portion of the CTM by 1 month post injury.

(d) The percentage of the area of areflexia that recovered after P188 treatment (mean ± SE).

And, here are good examples of clean, straightforward graphs from the Results sections of:

- a report describing the movements of neighboring cells in tissue culture (redrawn from Abercrombie and Heaysman, 1954).

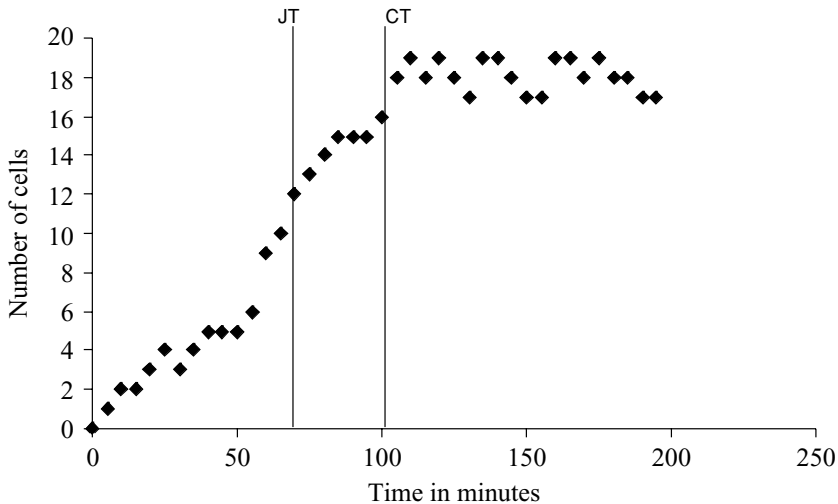

*Figure 1.* The number of cells in an area of interface between two explants during the approach and junction of the two sheets of cells, recorded at five-minute intervals. "JT" (Junction Time) is the time when opposing cells first make contact; "CF" (Close Fusion) indicates the time when the cells have become closely packed throughout the area observed.

- a report on cerebral suppression of sound in the opposite ear in split-brain patients (redrawn from Milner *et al.*, 1968).

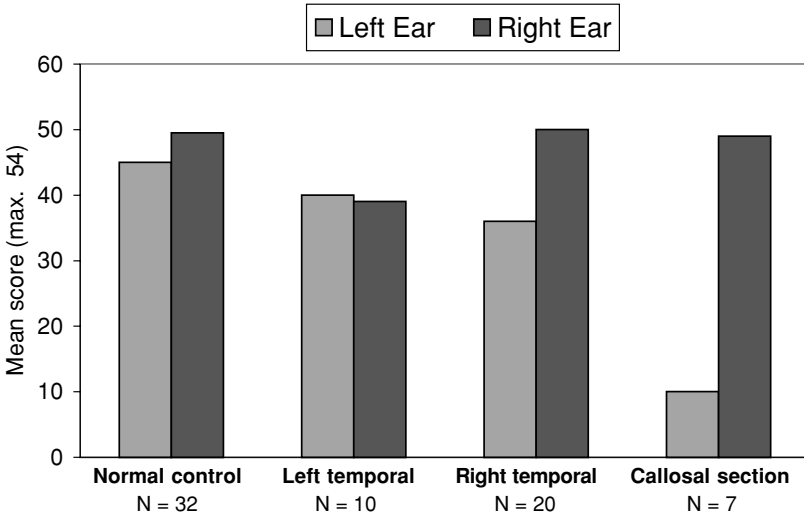

Figure 1. Mean number of digits correctly reported for each ear, when different digits are simultaneously presented to the two ears. The results are for normal control subjects and for three different patient groups.

- a report on the aging changes of Au/n-AlGa<sub>N</sub> Schottky diodes when exposed to air (redrawn from Readinger and Mohny, 2004).

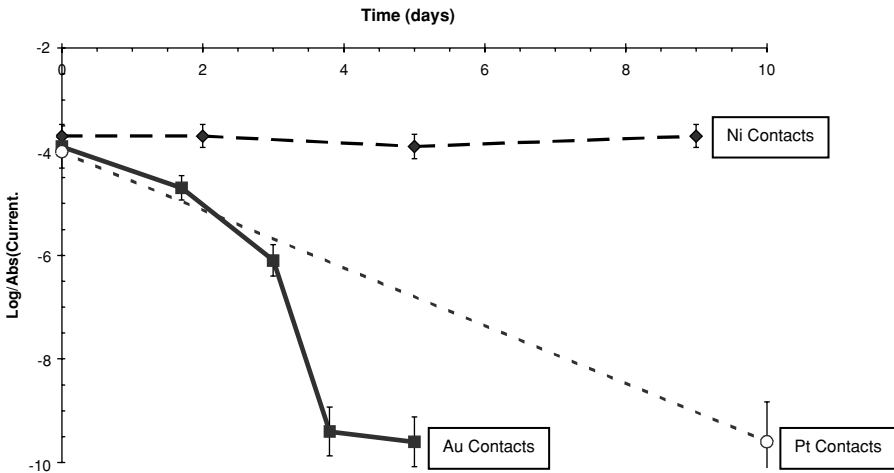

Figure 4. The  $J(\text{rev})$  at  $-5\text{V}$  for Au, Pt, and Ni diodes on n-AlGa<sub>N</sub> following exposure to air.

### 2.3.5.3. Case Studies

Lastly, present the full, unretouched details of one or two specific examples from your research set. Your reader will understand the paper better after seeing raw observations with all the complexities of the real world.

How do you choose these raw examples? There are two equally acceptable categories: best cases and representative cases.

2.3.5.3.1. *Best Cases*: Best cases show an extreme. They are the biggest, littlest, roundest, slowest, or fastest. Best cases fall at one end of the spectrum of your actual results—they show what *can* happen, not necessarily what usually *does* happen.

- If you are studying stripes on the backs of tarantulas, pick one of the spiders that had the most or the least stripes. You might write: “Only 2 of the tarantulas we found had >9 stripes. Tarantula C14 was one of those . . .” Then include a drawing or photograph of tarantula C14 with its dorsal stripes clearly visible. Write a brief note describing where and when that particular tarantula was found, its gender, its size, its color, and any other distinguishing features.
- If you are studying cell staining, you may find that your new stain is finicky. Perhaps the stain works infrequently, but when it does the results are dramatic. Although good examples are not common in your experiments, you can report these cases as best case examples. You might write: “Our new stain worked unpredictably, but we could usually find sections of the slide where cells stained crisply and in great detail. A good example is shown in Figure 1b. Two mature axons can be seen coursing longitudinally in parallel in the ventral marginal layer (large arrows). In addition, five tiny immature axons can clearly be seen growing radially, hugging the cell layer (small arrows).”
- Here is an example of a best case description from a report on the growth of individual axons and accompanying sheath cells followed in the living animal over periods of days to weeks (Speidel, 1932).

One of the most striking cases of primitive-sheath-cell activity and function is shown in the series of figure 11. A survey of the fins of this tadpole on May 30th revealed a place where a primitive sheath cell (M) appeared to be in the act of transferring from a larger nerve (ramus lateralis vagi, dorsal branch) to a very slender delicate fiber (fig. 11, a). This fiber (PP) extended distally for some distance beyond the field and was entirely devoid of primitive sheath cells. It could also be traced proximally for several myelin segments, as a non-myelin-emergent fiber. The nearest primitive sheath cell on this fiber was four myelin segments away. The appearance of the cell (M) suggested ameboid activity. For four days, however, its position remained unchanged, although the contour of the nucleus varied somewhat. It seemed that the region, instead of being one of active change, was rather one of stability. The transfer of this cell, however, was completed on June 4th (fig. 11, b). Cell division took place and the proximal daughter cell (M1) moved toward the terminal myelin segment (fig. 11, c). This cell transferred next to the myelin-emergent nerve sprout (fig. 11, d), and divided, giving rise to two cells (M1a and M1b, fig. 11, e). Thickening of the sprouts took place under the influence of these cells, and on June 9th two new myelin units were visible (fig. 11, f). On June 11th, these had increased both in diameter and in length (fig. 11, g). Likewise, the sprouts emerging from them became more complex. The distal primitive sheath cell (M2, fig. 11, d) also divided (fig. 11, e), but each of the daughter cells (M2a and M2b) remained quiescent and exerted no influence in stimulating myelin formation.

This is in marked contrast to the effect of the two cells which transferred to the myelin-emergent sprouts.

2.3.5.3.2. *Representative Cases*: Alternatively, you can show representative cases. Representative cases are modal cases, the most common examples in your data set.

- If you are studying stripes on the backs of tarantulas, pick one of the spiders that had the most common number of stripes. You might write: “Sixty-eight percent of the tarantulas we found had 8 stripes. A good example was Tarantula B11. . . .” Include a drawing or photograph of tarantula B11 with its dorsal stripes clearly visible. Write a brief note describing where and when that particular tarantula was found, its gender, its size, its color, and any other distinguishing features.
- If you are studying cell staining, you may find that your new stain almost always works well. You might write: “Figure 1b shows an example of the detail that is usually visible after using our stain. Two mature axons can be seen coursing longitudinally in parallel in the ventral marginal layer (large arrows). In addition, five tiny immature axons can clearly be seen growing radially, hugging the cell layer (small arrows).”
- Here is an example of a representative case description from a report on the role of *juvenile hormone* during the development of moths (Williams, 1961).

. . . only two of the eight animals transformed into normal pupae. The other six formed strange creatures in which a considerable number of tissues and organs had overleaped the pupal stage by undergoing precocious adult differentiation.

One of these animals is illustrated in Figure 2. The head shows the pigmented, faceted, compound eyes of the adult. The antennae exhibit the segmentation and subdivisions characteristic of early adult development. The thorax is covered with a mixture of rugose pupal cuticle and smooth cuticle of the adult type. The adult pata-gia have developed at the base of the fore-wings. The sclerotization of the thoracic tergum is adultoid. The thoracic pleura and sternum are covered for the most part by a smooth, adult-type cuticle. The legs show segmentation and the differentiation of tarsal claws and pulvilli. The proximal ends of the wings are covered by adult cuticle. The cuticle of the abdomen is wholly pupal, except in the immediate region of the genitalia; the latter are represented, not by imaginal discs, but by miniature adult genitalia which show an early elaboration of the various valves and adult structures. Dissection revealed that the fat-body was similar to that of a pupa after the initiation of adult development. Moreover, the ovaries showed the differentiation of ovarioles to a stage corresponding to that encountered in early adult development.

## 2.3.6. Example of a Complete Results Section

### Results

#### *Tissue sections*

The normal Bodian stain recipe (listed in the Materials and Methods) works well on young amphibian tadpoles. As reported in the standard literature (e.g. Luna 1960, Lillie 1965), the Bodian stain highlights the cytoskeleton of neurons. In

stained sections, mature axons and striated muscle appear black while cell nuclei are dull brown or purple. The Bodian stain also enhances melanin pigment granules. In the embryonic central nervous system, the marginal zone remains unstained except for the locations of those few axons sufficiently mature to contain many neurofilaments. In Bodian-stained sections, the few large, early-maturing axons can be followed individually. An example is shown in Figure 1a.

Our 10–12  $\mu\text{m}$  thick tissue sections were quite sensitive to the intensifier. Intensification for more than 3 min led to heavy black staining of cytoskeletons and of melanin granules, with a general black staining of the background. Intensification for 1 min produced only light background staining while clearly enhancing the cytoskeletons of cells. At 1 min intensification, the procedure did not stain structures (such as mitochondria) that are not normally blackened by the Bodian stain. Rather, 1 min intensification further darkened those cell structures that were only faintly stained by normal Bodian stain techniques.

Figure 1b shows an example of the detail that was usually visible after using the intensifier. Two mature axons can be seen coursing longitudinally in parallel in the ventral marginal layer (large arrows). In addition, five tiny immature axons can clearly be seen growing radially, hugging the cell layer (small arrows).

### *Cell cultures*

Fixed frog and chick cell cultures stain poorly with the standard Bodian techniques. Nuclei are the most prominently stained structures, taking on a dull brown or purple color. With Bodian staining, the thin cell processes, such as lamellipodia and axons, are almost invisible under standard microscopic illumination and require phase-contrast or DIC (Nomarski) imaging to be faintly seen. Examples are shown in Figures 1c and 1e.

On the other hand, our intensification procedure made cell processes readily visible under standard microscopic illumination. Examples are shown in Figures 1d and 1f. All cell types were stained clearly, and the thinnest cell process could be seen using DIC imaging. For example, microspikes could be clearly distinguished along the axon and at the axonal growth cone. Figure 2 shows one example of the most detailed and most clearly stained growth cones. Optimal enhancement required 10 min of post-staining intensification for cell cultures, as opposed to the 1 min required for thick tissue sections.

## 2.4. Discussion

### *Skeleton*

- A. Recap Your *Recipe* → *Results* Report
- B. List Other Researchers' Reports Using Similar Recipes
- C. Compare Your Results to Theirs
  1. List Similarities and Differences and/or
  2. Make a Prediction and/or
  3. Describe a Relevant Empirical Rule

The archives of science are enormous. Without some effort, your data will be invisible amidst the millions of other scientific observations already in storage.

The Discussion helps to make your paper memorable. In the Discussion:

- First, summarize your Results, consolidating your data to make it easier to remember.
- Next, make your data easy to find by linking it to other observations already reported in the scientific literature.

### 2.4.1. Recap Your Results

Begin your Discussion with a recap, a short summation of what you learned about the *key variables* of your data.

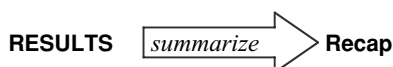

Example of a Recap:

We have described an intensification procedure for enhancing the Bodian staining of fixed cell structures. This intensification highlights and defines more clearly those cytoskeletal structures normally made only faintly black by Bodian silver. The Bodian silver stain has a high affinity for neurofilaments (Gambetti *et al.*, 1981, Phillips *et al.*, 1983). Our intensification procedure clearly reveals neurofilament bundles that are barely stained by standard Bodian techniques.

To see this concept played out in quite different settings, here are examples of recap paragraphs that begin the Discussion sections in a range of well-written scientific papers.

- A report on the Kaposi's sarcoma—associated herpesvirus (KSHV) effects on infected human cells (Glaunsinger and Ganem, 2004):

#### **Discussion**

We demonstrated previously that lytic KSHV replication promotes a widespread shutoff of cellular gene expression that likely occurs via enhanced mRNA turnover (10). In this report, we have further characterized the consequences

of this mRNA shutoff using microarray-based expression profiling. Our findings reveal that very few human transcripts accumulate during infection, including most of those induced by vGPCR.

- A report of measurements of the durations of very brief, localized calcium currents (“concentration microdomains”) in a presynaptic axon terminal (Sugimori *et al.*, 1994).

To understand in more detail the nature of these concentration microdomains, we obtained rapid video images (4000/s) after injecting the photoprotein n-aequorin-J into the presynaptic terminals of squid giant synapses. Using that experimental approach, we determined that microdomains evoked by presynaptic spike activation had a duration of about 800 ps. Spontaneous quantum emission domains (QEDs) observed at about the same locations as the microdomains were smaller in amplitude, shorter in duration, and less frequent. These results illustrate the time course of the calcium concentration profiles responsible for transmitter release. Their extremely short duration compares closely with that of calcium current flow during a presynaptic action potential and indicates that, as theorized in the past (6-8), intracellular calcium concentration at the active zone remains high only for the duration of transmembrane calcium flow.

- A report on using high doses of cytosine arabinoside (ARA-C) to keep patients with acute myeloid leukemia (AML) in continuous complete remission (CCR) (Bohm *et al.*, 2005):

#### 4. Discussion

Repetitive cycles of high dose ARA-C (HiDAC; ARA-C, 3g/m<sup>2</sup> twice a day on days 1, 3, and 5) have been introduced as an effective postremission treatment for patients with AML by the CALGB study group[16]. However, only a few confirmatory reports on the effects of this protocol have been published so far [14,17,18]. We here report the results of HiDAC consolidation for AML obtained in a single center. The overall survival of the remitters, the DFS, and the CCR at 4 years were 41, 34, and 39%, respectively. Our results are in line with results of the CALGB study group that reported an overall survival of remitters of 46%, a DFS of 39%, and a CCR of 44% at 4 years in their patients[16]. Together, these data demonstrate, that repetitive cycles of HiDAC represent a highly effective consolidation strategy for patients with AML in CR.

- A report on using the tri-block polymer P188 6 hr after a spinal cord injury in a mammal to increase the function and heal the structure of the spinal cord (Borgens *et al.*, 2004):

#### DISCUSSION

The use of tri-block copolymers in reversing membrane permeabilization in other injury and ischemia models were introduced earlier. We add to this emerging picture a beneficial usage of tri-block copolymers as an acute treatment for neuro-trauma. In particular, we report that a single subcutaneous injection of P188 6 hr after a standardized compression injury to the adult guinea pig spinal cord produced these three major findings: (1) the recovery of SSEP conduction was enhanced by



P188 treatment (90% of the population) compared to an insignificant spontaneous recovery in the control group; (2) the midthoracic injury produced a similar area of areflexia in the CTM reflex in both groups, although a statistically significant recovery of these silent receptive fields occurred only in response to P188 treatment; and (3) 3D reconstruction of all serial histologic sections comprising the injured segments of spinal cord showed that P188 treatment reduced the amount of pathologic cavitation of the cords and was associated with an increased volume of intact parenchyma.

- A report on the effect on animal diets of S-methylmethionine (SMM), a compound found only in plants: (Met = methionine) (Augsburger *et al.*, 2005)

## DISCUSSION

The objective of these experiments was to determine the bioavailability of SMM as either a Met or choline source, using a Met- and choline-deficient semipurified diet previously shown to respond markedly to dietary additions of either nutrient (23). The marked responses in growth performance when SMM was added to choline-deficient, Met-adequate diets in Assays 1, 3, and 4 showed that SMM exhibited choline-sparing bioactivity; indeed, SMM exhibited 20% bioequivalence (wt:wt) to choline per se. Conversely, scrutiny of the data in Assays 1 and 2 suggested that SMM probably did not exhibit Met activity in chicks.

- A report examining the ultrasound echogenicity of the substantia nigra in Parkinson's disease: (PD = Parkinson's disease, SN = substantia nigra) (Berg *et al.*, 2001)

### Discussion

This study confirms our previous findings of increased SN-echogenicity in PD patients [2]. The proportion of distinctly hyperechogenic SNs in the group of PD patients, however, was higher which is likely to reflect improvements in the ultrasound technology in the last five years. In 91% of PD patients the extent of hyperechogenic signals at the SN was well beyond the standard deviation of an age matched control group while only 9 out of 103 PD patients (8.7%) exhibited SN signal intensity within the normal range. Moreover, PD patients with a more extended hyperechogenic signal had an earlier disease onset. Additionally, these PD patients showed more often motor complications like fluctuations, dyskinesia and freezing when analysis was controlled for the duration of disease. . . .

#### 2.4.2. Fitting into the Scientific Archives

Use the remainder of the Discussion to tie your data to data that is already in the scientific archives. There are three general approaches.

##### 2.4.2.1. Compare

Make a list or a table of similar scientific reports that already exist. Then describe how your data relate to each of these reports. If you have developed a new stain, for instance, you can list existing stains and describe, point-by-point, how your stain compares to the others.

Here is how you might tabulate the similarities between your data and the data of three existing scientific reports, indicating matching data with a ‘↔’:

your data	report x	your data	report y	your data	report z
ab	aa	ab ↔	ab	ab ↔	ab
ac	↔ ac	ac ↔	ac	ac ↔	ac
dd	cc	dd	–	dd	cc
df	↔ df	df ↔	df	df ↔	df
dh	↔ dh	dh ↔	dh	dh	dg
ea	↔ ea	ea ↔	ea	ea ↔	ea
eb	↔ eb	eb ↔	eb	eb ↔	eb
fn	fe	fn ↔	fn	fn	–
hw	↔ hw	hw ↔	hw	hw ↔	hw
hx	–	hx ↔	hx	hx	–

Next, translate your comparative table into a clear narrative text.

To illustrate how comparisons have been written in a wide variety of Discussions, here are some good examples.

- A report on the use of vital dye to determine the fates of parts of the amphibian neural plate (Jacobson, 1959):

*The external limit of the brain-forming area*

The limit between presumptive brain and presumptive skin has previously been dealt with in a number of papers based upon vital staining. Woerdeman (1929) and Fautrez (1942) were of the opinion that the boundary coincides with the outer limit of the neural plate. Already in 1939 it had, however, been clearly shown by Baker & Graves that the inner half of the transverse ridge takes part in the formation of the brain. The same result was reached by Horstadius & Sellman (1946) who, on the basis of their own results and those of earlier authors, discussed the problem in detail. Their result differs from those of the present investigation in that they indicate (in their Fig. 5c, p. 15) that material belonging to the first four of the zones distinguished by them in the neural ridge participates in the formation of the brain. According to my division, these zones would closely correspond to the ridge level with **I** and half of **II** (Text-fig. 1). Experiments VC 26, VC 27, VC 38, VC 51, VD 7, and VD 11 show that the limit of the presumptive brain cannot be situated upon the ridge farther back than the region which corresponds to Horstadius & Sellman’s zone 1 plus the cranial part of zone 2. Experiment VD 24 and others show that this limit, where it is situated upon the transverse ridge, must be drawn as in Text-fig. 16.

- A report on using high doses of cytosine arabinoside (ARA-C) to keep patients with acute myeloid leukemia (AML) in continuous complete remission (CCR): (CALBG = Cancer and Leukemia Group B, HiDAC = high dose ARA-C) (Bohm *et al.*, 2005)

Another prognostic parameter examined was age. It is generally accepted, that younger patients (aged <60 years) have a superior outcome compared to elderly patients [27,31,32]. The data of the CALGB study group have also demonstrated that age is a predictive factor for the outcome of therapy in younger AML patients [16]. These results could be confirmed in the present study. In fact, the outcome of therapy in patients aged under 40 years was significantly better compared to the survival in older patients (age 40–60 years). All in all, HiDAC seems to be a most effective postremission regimen in younger patients with favorable karyotype, but also in a group of patients with intermediate karyotype. In this regard it should be stated that our patients in general may resemble a relatively good risk group of AML (<60 years, CR).

- A report of measurements of the durations of very brief, localized calcium currents (“concentration microdomains”) in a presynaptic axon terminal (Sugimori *et al.*, 1994):

The time course reported here is different from that observed in other secretory systems such as the chromaffin cell (14) where the transient develops over 1 to 100 ms and where the calcium buffering properties may be quite different. However, our results are similar to the calcium concentration profile in individual frog-muscle sarcomeres following the activation of action potentials (14).

- A report on the comparison of the atomic weight of ordinary lead with lead of radioactive origin (Richards and Lambert, 1914)

This matter has received not only speculative but also experimental treatment at Harvard. For many years the possibility that samples of a given element from different sources might have different atomic weights had been considered, and investigated, but never before with a positive outcome. In the first investigation of the atomic weight of copper undertaken by one of us as long ago as 1887,[7] samples of copper obtained from Germany and from Lake Superior were found to give precisely the same atomic weight for this element. More recently the question was revived and in 1897, specimens of calcium carbonate were obtained from Vermont, U. S. A., and from Italy, in order to discover whether or not the calcium in these two widely separated localities had the same atomic weight. Not the slightest difference was found between them.[8] Again, in a very elaborate investigation on the atomic weight of sodium,[9] silver was obtained partly from several distinct sources and sodium chloride was obtained partly from several different samples of German rock salt, and partly from the salt pumped from the Solvay Process Company’s mines at Syracuse, N. Y. These preparations, differing widely in the steps of manufacture and in geographical source, all yielded essentially the same atomic weights within the limit of error of the process.[10] Yet more recently Baxter and Thorvaldson,[11] with the same possibility in mind, determined the atomic weight of extra-terrestrial iron from the Cumpas meteorite, which gave a result identical with ordinary iron within the limit of error of experimentation. From these researches it would seem probable that even if an unusual eccentricity may be exhibited by lead, most elements do not as a rule differ from any such cause

of uncertainty. Baxter and Grover are now engaged in the examination of ordinary lead from different geographical sources. Perhaps this also contains more than one component, as suggested above.

- A report on the relatively low number of studies on motor control in the psychological literature: (Rosenbaum, 2005)

Another reason to expect motor control to become more popular in psychology is the emergence of ecological psychology and dynamical systems analysis. Advocates of ecological psychology argue that the primary function of perception is to guide action (Gibson, 1979) and that the control of action enlists rather than resists physical properties of actor-environment couplings (Bernstein, 1967). Advocates of dynamical systems analysis seek to describe ongoing cycles of perceiving and acting in the form of differential equations (e.g., Sternad, Duarte, Katsumata, & Schaal, 2001). The advent of the ecological and dynamical systems perspectives has fostered the analysis of classes of behavior that were left out of the research portfolio of traditional cognitive psychological research, which focused on internal representations and computations to the exclusion of embodied cognition (Clark, 1997; Glenberg, 1997). Newly studied topics include walking and jumping (Goldfield, Kay, & Warren, 1993; Thelen, 1995), juggling (Beek & Turvey, 1992), skiing (Vereijken, Whiting, & Beek, 1992), pistol shooting (Arutyunyan *et al.*, 1969), wielding objects (Carello & Turvey, 2004), bouncing a ball on a tennis racquet (Sternad *et al.*, 2001), swinging two handheld pendulums of different lengths and weights (Turvey, 1990), and oscillating two index fingers at different frequencies and relative phases (Zanone & Kelso, 1997).

- A report on the use of proton magnetic resonance spectroscopy to assess the severity of damage in a shaken infant (Haseler *et al.*, 1997):

Numerous MRS studies are now available to document the metabolic changes in infant brain subject to a variety of injuries. To our knowledge, we are the first to indicate the nature and severity of the biochemical response to traumatic injury, but Auld *et al.*, (16) describe other patterns in a variety of nontraumatic (17,18) brain injuries. Hypoxic injury also results in loss of NAA and accumulation of lactate. The pattern seen here in SBS appears somewhat different from hypoxic injury alone (19). A larger study is required to establish the specificity, if any, of any of the differences seen in our small series, to SBS.

- A report on the effects of three natural agonists on the contraction of smooth muscle in lung airways: (ACH = acetylcholine, SMCs = smooth muscle cells) (Perez and Sanderson, 2005)

Previous investigations of  $\text{Ca}^{2+}$  signaling in rat (Tolloczko *et al.*, 1995, 1997) or dog (Yang *et al.*, 1997; Yang, 1998) tracheal SMCs used low-speed sampling systems to report that 5-HT induced an initial transient followed by a sustained elevation in  $[\text{Ca}^{2+}]_i$ . By contrast, we found with video-rate confocal microscopy that 5-HT induces repetitive transients in  $[\text{Ca}^{2+}]_i$  or  $\text{Ca}^{2+}$  oscillations in airway SMCs. In most respects, the 5-HT-induced  $\text{Ca}^{2+}$  oscillations were similar to those induced by ACH, both in this and previous studies with lung slices (Bergner and

Sanderson, 2002a, 2003) or isolated tracheal airway preparations (Prakash *et al.*, 1997, 2000; Roux *et al.*, 1997; Kuo *et al.*, 2003). The Ca<sup>2+</sup> oscillations persisted with a steady frequency and usually originated at one end of the cell and spread toward the other end as a Ca<sup>2+</sup> wave, although the direction of the Ca<sup>2+</sup> waves could be reversed. The Ca<sup>2+</sup> waves were unsynchronized between neighboring cells and did not propagate to adjacent cells, suggesting that each wave originated within each cell. It is important to note that each Ca<sup>2+</sup> oscillation did not generate a twitch of contraction but that the SMCs maintained a steady contractile state.

**2.4.2.2. Combine**

Another way to tie into the extant scientific literature is by combining your results with other existing data. Try to fit your data together with data of others so that the combination makes a coherent whole. If possible, describe this new construction as a specific testable prediction.

Perhaps you have found three other reports of similar experiments. By combining your results with theirs—by proposing that your results can be usefully tied to theirs—you can expand the range of observations that are available for understanding the phenomenon under study.

your data	report x	your data	report y	your data	report z
ab	aa	ab ↔	ab	ab ↔	ab
ac ↔	ac	ac ↔	ac	ac ↔	ac
dd	cc	dd	–	dd	cc
df ↔	df	df ↔	df	df ↔	df
dh ↔	dh	dh ↔	dh	dh	dg
ea ↔	ea	ea ↔	ea	ea ↔	ea
eb ↔	eb	eb ↔	eb	eb ↔	eb
fn	fe	fn ↔	fn	fn	–
hw ↔	hw	hw ↔	hw	hw ↔	hw
hx	–	hx ↔	hx	hx	–

The combined results can be offered, for example, as predictions that the full range of data for this type of experiment is the union of all the different data values, namely:

$$\text{Union} = \{aa\ ab\ ac\ cc\ dd\ df\ dg\ dh\ ea\ eb\ fe\ fn\ hw\ hx\}$$

and that the essential data (the “least common denominator”) resulting from any experiment of this type is the intersection of all the different data values, namely:

$$\text{Intersection} = \{ac\ df\ ea\ eb\ hw\}$$

In this way, combining your data with existing data, you might predict that all other attempts at this type of experiment will produce a data set containing {ac df ea eb hw}, with any other data values being only from the set {aa ab cc dd dg dh fe fn hx}.

Or, consider the case of a new stain you have developed that effectively blackens neurofilaments. Neurofilaments are the intermediate filaments in nerve cells. You

could combine your results with existing data that demonstrate the molecular similarity between neurofilaments and glial filaments (the intermediate filaments in glial cells). Then, you could predict that your new stain should also stain glial cells.

To illustrate how experimental data have been combined with other known data to make predictions, here are excerpts from insightful Discussions in a variety of science articles.

- A report of growth of individual axons and accompanying sheath cells followed in the living animal over periods of days to weeks (Speidel, 1932):

Sheath cells in general migrate from proximal to distal. During early development such centrifugal movement is especially noticeable. It is also quite obvious in actively generating areas in which the growth urge is strong (compare figs. 1, 2, and 13). However, in the later stages after the first flush of growth is over, the primitive sheath cells now occasionally migrate in a proximal direction (centripetal movement). This is particularly noticeable in connection with the transfer of primitive sheath cells to myelin-emergent sprouts (compare figs. 8 to 11). Harrison's ('24) statement that he has never seen sheath cells migrate proximally is probably to be explained by the fact that his observations were on very young tadpoles in which the centrifugal growth urge was still quite strong.

- A report on the effect on animal diets of S-methylmethionine (SMM), a compound found only in plants: (Met = methionine) (Augsperger *et al.*, 2005)

The presence of SMM in foods and feeds adds one more complicating factor to the proper assessment of the requirement and bioavailability of choline. In mammalian species, but not avians, excess dietary Met can eliminate the dietary need for preformed choline (17, 18, 36, 37), and betaine, which is also present in many foods and feeds (38), can replace the methylation function of choline (31). Thus, previous attempts to obtain clear-cut animal responses to choline supplementation of corn-soybean meal diets have often met with failure (18, 39), probably due not only to significant concentrations of choline per se in soybean meal but also to the presence of both betaine and SMM in this ingredient. Moreover, previous research in which the bioavailability of choline per se in soybean meal was found to be as high as 80 (22) to 100% (40) probably represents over estimates. It is apparent that when considering a dietary need for bioavailable choline, choline itself as well as betaine and SMM levels in foods and feeds must be taken into account. For mammalian species, including humans, excess dietary Met is also capable of sparing choline.

- A report on using high doses of cytosine arabinoside (ARA-C) to keep patients with acute myeloid leukemia (AML) in continuous complete remission (CCR) (Bohm *et al.*, 2005):

So far, it remains unknown whether the intensity of the postremission treatment can be reduced. Notably, only a few data exist indicating how many consolidation cycles are required to maintain long term CR in patients with AML [28,29]. In the original HiDAC protocol, a maximum of four cycles of consolidation were

applied. Thus, the primary intention of the present study was to give a total number of four consolidation cycles as well. Indeed, a slight majority (56.8%) of the 44 patients undergoing consolidation (at least one cycle of HiDAC) received all four planned consolidation cycles. Another 22.7% of these patients received three cycles of HiDAC. It is of interest, that in the group of patients receiving three cycles of HiDAC, we were able to identify several patients who showed long term disease-free survival. Therefore, it is tempting to speculate that a reduction of the number of HiDAC consolidation cycles to three may be possible and may be equally effective compared to four cycles [28]. However, since we did not randomize our patients in the different groups receiving three or four cycles, this question could not be addressed for our patients in this study.

- A report consolidating evidence of the speed of extinction of North American dinosaurs (Fastovsky and Sheehan, 2005):

The conclusion that the extinction of the dinosaurs was geologically instantaneous precludes longer-term causes (e.g., events on million to ten-million-year timescales). So, although survivorship patterns may be in accord with habitat fragmentation-based models, habitat fragmentation as the driving force for the dinosaur extinction is problematical, because it is linked in this case to a marine regression that occurred over a million or more years. Moreover, recent stratigraphic work summarized in Johnson *et al.*, (2002) suggests that the Hell Creek was deposited rather quickly (over  $\sim 1.4$  m.y.; Hicks *et al.*, 1999, 2002) in a transgressive setting (the final transgression of the North American Western Interior Sea). This interpretation is concordant with a previously inferred rise in the water table (Fastovsky and McSweeney, 1987). The transgressive geological setting is antithetical to the proposed fluvial lengthening associated with the habitat fragmentation scenario and suggests that it was not likely a factor in the North American dinosaur extinction.

- A report on the Kaposi's sarcoma-associated herpesvirus (KSHV) effects on infected human cells (Glaunsinger and Ganem, 2004):

It is interesting that three of the induced genes in Table II are involved in cellular transcription. In particular HIF-1 is a heterodimeric basic helix-loop-helix transcription factor that becomes stabilized under hypoxic conditions. Stabilized HIF-1 dimerizes with HIF-1 and transcriptionally activates several genes responsive to low oxygen whose products play critical roles in tumor progression including angiogenesis, cell growth, and energy metabolism (24). Although we did not observe the escape of many HIF-1 target genes in infected cells, one HIF-1 target is up-regulated; that is, the transcript for solute carrier family 2, member 3 (GLUT3). Interestingly, it has been reported that hypoxia also induces KSHV lytic reactivation (25), an event likely mediated by the presence of functional hypoxia response elements within the RTA and ORF34 promoters. Thus, an additional function for HIF-1 in lytic cells may be to enhance KSHV replication via the stimulation of select viral promoters, the products of which are not subject to shutoff.

- A report of measurements of the durations of very brief, localized calcium currents (“concentration microdomains”) in a presynaptic axon terminal (Sugimori *et al.*, 1994):

The number of calcium ions that are detected in an evoked microdomain may be estimated as follows. Consider that a presynaptic action potential generates an  $I(\text{Ca})$  of about 300 nA (10, 13), a current of 0.5 pA/channel, and that a single channel allows the flow of about 150 to 200 calcium ions (7, 18), then  $\sim 6 \times 10^5$  channels are opened to release 5000 to 10,000 vesicles (4, 11) or  $\sim 15,000$  calcium ions/vesicle (13). [This is in contrast to the estimated minimum of 200 ions/vesicle (one calcium channel) for the ciliary ganglion (18)]. Given that the number of active zones in a presynaptic terminal is about 5000 to 10,000 (6), the number of channels open per action potential for each active zone is  $\sim 100$ . If single channels allow the flow of 150 to 200 calcium ions (7, 18), an evoked microdomain, using n-aequorin-J and the present imaging technique, may represent an influx of calcium of about 15,000 ions.

- A report examining the ultrasound echogenicity of the substantia nigra in Parkinson’s disease: (PD = Parkinson’s disease, SN = substantia nigra) (Berg *et al.*, 2001)

The reason for the increase in echogenicity is still unclear. Morphological changes occurring at the SN in PD which may lead to an alteration in tissue impedance and therefore SN echogenicity are several: Loss of pigmented neurons may result in tissue condensation, proliferation of microglia may increase cellular interfaces, and elevated heavy metal tissue content (especially an increase of iron) [9, 13, 16, 27, 28] may modify tissue impedance. According to recent findings iron is supposed to be a major source for the increased echogenicity of the SN; neurochemical and sonographic analyses of post mortem material revealed a close correlation between SN echogenicity and iron tissue content (Berg *et al.*, unpublished). In addition, animal experiments have demonstrated more intense tissue echogenicity induced by increasing amounts of iron injected into the SN [4]. Therefore, we surmise that SN hyperechogenicity in PD might (at least in part) be due to disease-associated elevation of SN iron levels. Iron is supposed to play a pivotal role in the degeneration of SN neurons in PD, as it facilitates and accelerates neurodegeneration by formation of free radicals and lipid peroxidation [14, 20, 30]. In the light of these observations, one may speculate that increased echogenicity of the SN might reflect higher tissue iron content which, on the other hand, could increase the oxidative stress within the SN resulting in a more rapid degeneration of SN neurons.

- A report on the apparent disintegration of nitrogen atoms by radioactive bombardment (Rutherford, 1919)

Taking into account the great energy of motion of the alpha particle expelled from radium C, the close collision of such an alpha particle with a light atom seems to be the most likely agency to promote the disruption of the latter; for the forces on the nuclei arising from such collisions appear to be greater than can be produced by any other agency at present available. Considering the enormous intensity of the



force brought into play, it is not so much a matter of surprise that the nitrogen atom should suffer disintegration as that the alpha particle itself escapes disruption into its constituents. The results as a whole suggest that, if alpha particles—or similar projectiles—of still greater energy were available for experiment, we might expect to break down the nucleus structure of many of the lighter atoms.

### 2.4.2.3. Find an Empirical Rule

A third possible way to tie into the existing archives of science is to generalize your observations into a theory. In science, the first step in building a theory is to infer empirical rules from many individual experiments. Therefore, you might begin by proposing an empirical rule based on your data.

An empirical rule is a summary of a number of *recipe* → *results* reports. Empirical rules are also called hypotheses, principles, or proposals.

- *Empirical Rules*: An empirical rule says:

Here are the paper-and-pencil operations that will predict the results of any recipe of *Type A* without actually having to go through the operations of the recipe.

In other words, an empirical rule has two parts:

- Part **1** describes the characteristics of *Type A* recipes.
- Part **2** gives the paper-and-pencil operations that will predict the results of any recipe fitting the *Type A* definition.

#### **Example**

*Name:* The Empirical Rule of Water-plus-Water Volumes

*Summary:* Any recipe adding X ml of water to Y ml of water will give you X+Y ml of final solution.

*Definition:*

Part **1** -- The type of recipes covered are those in which one volume of water is added to another volume of water.

Part **2** -- The pencil-and-paper operation for predicting end-volumes is the simple addition of the two beginning volumes.

*Usage:* If you know this empirical rule, it is unnecessary for you to actually mix 74.1 ml of water with 22 ml of water. With only a pencil and a piece of paper, you can predict that the result will be 96.1 ml of final solution.

Besides being the building blocks of scientific theories, empirical rules save you endless hours of work—either experimental work or the library work necessary to find out if someone else has already reported the results of your particular recipe. The broader the rule, the more work it saves. Broad, inclusive rules are indispensable for fast-paced science.

**Example**

*Name* : The Empirical Rule for The Freezing Point of Salt Water

*Summary* : Any recipe adding X mg of table salt to Y ml of water lowers the freezing point (109)(X/Y) degrees Celsius below the freezing point of water alone.

*Definition* :

Part 1 -- The type of recipes covered are those in which NaCl is added to water.

Part 2 -- The pencil-and-paper operation for predicting the resulting freezing point FP is:

$$FP = (-109) \times (\text{mg NaCl}) / (\text{ml water})$$

*Usage*: If you know this empirical rule, it is unnecessary for you to actually mix 212 mg of NaCl into 3500 ml of water. With only a pencil and a piece of paper, you can predict that the resulting solution will freeze at -6.6 degrees Celsius.

2.4.2.3.1. *The Natural Life-Cycle of an Empirical Rule*: Good rules are inclusive, but they cannot be all-inclusive. The real world has unending complexity. When an empirical rule is repeatedly checked against the world, specific recipes surface with results that the rule has not predicted accurately. When this happens, the researcher modifies either:

Part 1—the description of the recipes that the rule can handle, or

Part 2—the details of the rule's paper-and-pencil operations for predicting results.

As research goes on, the weight of the modifications eventually makes most empirical rules too complex and too exception-laden to be time-saving. Now, researchers start again and build a new rule. The unending revision of empirical rules is the natural and healthy life of scientific research.

2.4.2.3.2. *An Empirical Rule for Your Recipe*: The core of each scientific paper is its *recipe* → *results* report. You can formalize the comparison of your data with data from other existing reports if, in the Discussion of your paper, you fit your *recipe* → *results* report into an empirical rule.

Begin by searching the scientific literature for an existing empirical rule that deals with recipes of the type you describe in your Materials and Methods. Two things can happen:

1) *You discover an existing empirical rule that applies to your recipe.*

If you find a rule that accurately predicts your results, then end your Discussion by pointing out that you have shown a new example covered by this existing empirical rule. On the other hand, you may find an applicable rule, but you may discover that it does *not* accurately predict your results. In this case, look in the scientific annals for other examples of similar recipes giving unpredicted results. List the recipes that don't fit the existing empirical rule. Are there things in common among these misfits?

You do not need to fix the rule. Just help your reader by describing the rule and then compiling as comprehensive a list as possible of recipes that this rule cannot handle.

2) *You do not find an empirical rule that applies to your recipe.*

If you can't find an appropriate empirical rule, try to propose your own rule. Search the scientific literature, and make a list of recipes similar to yours. To propose a new rule, you first describe the common features of the applicable recipes. Next, you list the pencil-and-paper operations that will accurately predict their results. That's it. You have written a new empirical rule. Put it at the end of your Discussion.

This explanation of empirical rules may seem a bit abstract. To give it some substance, here are empirical rules that have been offered in a variety of Discussions.

- A report describing the movements of neighboring cells in tissue culture (Abercrombie and Heaysman, 1954):

Our results lead to the conclusion that there is some restriction on the movement of fibroblasts over each other's surfaces. It is a restriction that does not apparently operate at a distance to hinder the mutual *approach* of fibroblasts. Fibroblasts therefore freely make contact with each other and, in fact, adhere together (5) forming the meshwork so characteristic of their growth. The restriction operates only after contact has been established. There is evidence (1) that the initial reaction to contact is a slight acceleration of the movement of the cells towards each other. After that there usually occurs a prohibition of further movement in this direction. The prohibition does not invariably occur in the conditions we have investigated, since there develops some overlapping of cells; and we have as yet no conclusive information as to how important the prohibition is in cultures grown for more than 36 hours, or grown in different media.

This directional prohibition of movement we shall refer to briefly as "contact-inhibition." . . .

- A report of growth of individual axons and accompanying sheath cells followed in the living animal over periods of days to weeks (Speidel, 1932):

*New principles of peripheral nerve development with reference to the formation and growth of the myelin sheath*

In his monumental work on the degeneration and regeneration of the nervous system, Cajal ('28) enunciates a number of principles or laws of neurogenesis, fourteen of which deal with intrinsic factors and fifteen with extrinsic factors. Nothing is given on the process of myelination. As a result of my observations on living frog tadpoles, I propose, in a tentative way, the following new principles of neurogenesis for the peripheral nerves to supplement the list given by Cajal. All of these relate to the mechanism of nerve fiber myelination.

1. *A myelin-emergent nerve sprout differs from a non-myelin-emergent fiber. The former in combination with a primitive sheath cell leads to the formation of a new myelin segment, the latter ordinarily does not.*

2. The transfer of a primitive sheath cell from a non-myelin-emergent fiber to a myelin-emergent fiber may be effected in a variety of ways, but the reverse transfer is rare. Transfer from one myelin-emergent sprout to another may also take place.

3. Early unmyelinated nerves serve, in a general way, to direct advancing myelin-emergent nerve sprouts, and to furnish them with primitive sheath cells as a preliminary step of myelination. . .

- A report on the role of *juvenile hormone* during the development of moths (Williams, 1961):

#### 4. Theory of juvenile hormone action

...

From this summary we learn that the role of juvenile hormone is to modify the cellular reactions to ecdyson. It appears to do so by opposing progressive differentiation without interfering with growth and molting in an unchanging state. In some unknown manner, it blocks the de-repression and de-coding of fresh genetic “information” without interfering with the acting-out of information already at the disposal of the cells.

- A report of improvements to a model of the release kinetics of solute from a polymeric matrix, with experimental tests of the improved model (Paul and McSpadden, 1976):

We conclude that the refinements of the Higuchi model offered here (via the relaxation of the “pseudosteady-state” assumption) have some advantages for describing release kinetics for loadings where  $A/C(s)$  is slightly greater than one, but become virtually identical with Higuchi’s equation for large values of  $A/C(s)$ . The incorporation of a finite external mass transfer resistance into the models for release kinetics makes these results more valuable for describing situations normally encountered in most applications. The refined model in conjunction with the classical solution to Fick’s law for  $A/C(s) < 1$  offer an accurate set of equations for describing release rates over the entire range of  $A/C(s)$ , provided of course the condition of rapid dissolution of undissolved solute is applicable.

- A report on the Kaposi’s sarcoma–associated herpesvirus (KSHV) effects on infected human cells (Glaunsinger and Ganem, 2004):

Given the powerful constitutive signaling activity of vGPCR and its intrinsic proangiogenic character, one paradox has been why KS develops so infrequently after KSHV infection. In Western societies, where 2–7% of the population is KSHV infected, KS is largely limited to those developing HIV infection or receiving iatrogenic immunosuppression. The attenuation of VEGF and other vGPCR-dependent gene induction events by KSHV-induced shutoff leads us to propose that only infections with extensive lytic replication, such as those that may occur during cellular immune dysfunction, can generate sufficient VEGF to contribute meaningfully to KS progression. This inference accords well with clinical observations that link KS progression to elevated levels of circulating KSHV DNA (18).

- A report consolidating evidence of the speed of extinction of North American dinosaurs (Fastovsky and Sheehan, 2005):

### Death by Asteroid

The current “alternative hypothesis” for the cause of the extinction of the dinosaurs is, of course, an asteroid impact with Earth. Schultz and d’Hondt (1996), using the morphology of the crater as an indicator of the angle and direction of the impact, proposed that the Western Interior of North America would bear the brunt of impact effects. In all scenarios, wholesale extinctions on extremely short timescales are presumed to be a consequence of such an event. While the extinction cannot be shown to have occurred within hours, days, or weeks, extinction timescales can be constrained to a few tens of thousands of years or less. For this reason, what is known of the rate of the dinosaur extinction in North America is concordant with the predicted effects of an asteroid.

- A report on the effects of three natural agonists on the contraction of smooth muscle in lung airways: (CICR = calcium-induced calcium release, RyR = ryanodine receptor channel, SMCs = smooth muscle cells, SR = sarcoplasmic reticulum) (Perez and Sanderson, 2005)

From this data we hypothesize that the KCl-induced  $\text{Ca}^{2+}$  oscillations are the result of the following events. Initially, KCl induces membrane depolarization and initiates an influx of  $\text{Ca}^{2+}$  via L-type and/or T-type  $\text{Ca}^{2+}$  channels. The cell compensates for this rise in  $[\text{Ca}^{2+}]_i$  by transporting the extra  $\text{Ca}^{2+}$  into the SR via SERCA pumps. Because of their limited capacity, the stores quickly overload as indicated by the increasing frequency of the elemental  $\text{Ca}^{2+}$  events, which reflect sensitized RyRs. Upon reaching a critical  $\text{Ca}^{2+}$  load, the elemental  $\text{Ca}^{2+}$  events trigger an extended phase of CICR via sensitized RyR to empty the store and generate a  $\text{Ca}^{2+}$  wave with a transient SMC contraction before initiating the cycle again.

#### 2.4.2.4. Link to the Results of Others

To summarize—in whichever way you find best, use the bulk of your Discussion to relate your observations to the observations of others. By linking your results to the results of other researchers, you fit your data into the existing scientific archives.



Example of a brief, complete Discussion section:

### **Discussion**

We have described an intensification procedure for enhancing the Bodian staining of fixed cell structures. This intensification highlights and defines more clearly those cytoskeletal structures normally made only faintly black by Bodian silver. The Bodian silver stain has a high affinity for neurofilaments (Gambetti *et al.*, 1981, Phillips *et al.*, 1983). Our intensification procedure clearly reveals neurofilament bundles that are barely stained by standard Bodian techniques.

Isolated neurons show their innate characteristics best *in vitro*. In tissue culture, the movements and the interactions of neurites can be seen clearly in micro-environments that can be controlled precisely (Harrison 1910, Speidel 1932 1933, Pomerat *et al.*, 1967, Tennyson 1970, Bunge 1976, Pfenninger and Reese 1976, Bray 1982, and Letourneau 1985). Our intensification procedure offers a new tool for tissue culture studies of embryonic and immature axons, both of which have relatively few neurofilaments.

For tissue culture, our Bodian stain intensification has these features:

- a) it works for standard tissue culture procedures,
- b) it works on a variety of tissues,
- c) the degree of intensification is approximately proportionate to the duration of treatment,
- d) it effectively reveals cell processes as thin as microspikes in simply-fixed light microscopic preparations.

## 2.5. Conclusion

### *Skeleton*

One paragraph statement of the point of the paper

### 2.5.1. End Your Paper with a Firm Conclusion, the Essential Point of the Paper

Each scientific article should equal one or two main ideas. These should be stated in the Conclusion. The Introduction of the paper gives the current scientific context of these ideas, the Discussion shows how your data lead to or support the ideas, and the Conclusion summarizes the ideas in one succinct paragraph. Some journals use a format that includes a section labeled “Conclusion” or “Summary,” otherwise add your Conclusion to the very end of the Discussion.

When you first face the Conclusion section of your paper, you should already have a draft of the Discussion. The Discussion moves from your specific observations to more general statements related to the work of others. For your Conclusion, take the recap from the beginning of your Discussion and the general statements from the end, and forge a single uncluttered paragraph.

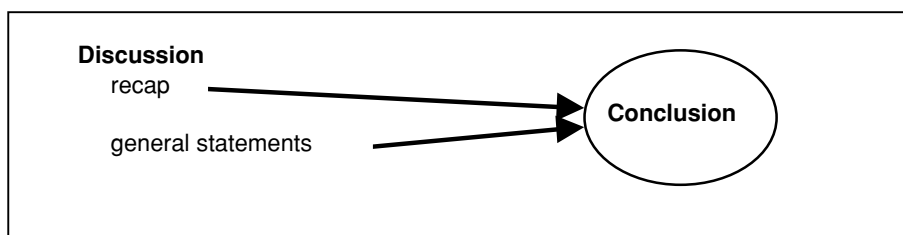

Example of a Conclusion:

### **Conclusion**

Our intensification of standard Bodian stained cells can outline fine cell processes in tissue sections and in fixed tissue cultures. The details of individual growth cones of cultured neurons are especially clearly stained and can be seen well with light microscopy.

### 2.5.2. Conclusions From Many Papers

Here, from a variety of scientific articles, are examples of straightforward Conclusions that clearly state the points of the papers.

- A report describing the movements of neighboring cells in tissue culture (Abercrombie and Heaysman, 1954):

It is concluded that fibroblasts avoid moving over each other’s surfaces. Such “contact-inhibition” of movement can explain why it is that fibroblasts normally

migrate predominantly radially from an explant and that the whole culture tends rapidly to become circular in plan whatever its initial form.

- A report on using high doses of cytosine arabinoside (HiDAC) to keep patients with acute myeloid leukemia (AML) in continuous complete remission (CCR) (Bohm *et al.*, 2005):

Together, our data provide further evidence that post-remission therapy with HiDAC is a safe and effective consolidation treatment for AML patients in CR aged less than 60 years. The optimal number of consolidation cycles and the subgroups of patients who benefit most from this regimen remain to be defined in forthcoming trials.

- A report on using the tri-block polymer P188 6 hr after a spinal cord injury in a mammal to increase the function and heal the structure of the spinal cord: (PEG = polyethylene glycol, ROS = free radicals, LPO = lipid peroxidation) (Borgens *et al.*, 2004)

In summary, P188 may be a free radical scavenger (Marks *et al.*, 2001), whereas PEG is not. They both, however, directly reduce ROS and LPO in the damaged nervous system. Furthermore, they both provide neuro-protection to injured spinal cord and thus will continue to be investigated as potential therapies, simple to apply, for various forms of neurotrauma.

- A report consolidating evidence of the speed of extinction of North American dinosaurs: (K-T = Cretaceous-Tertiary period boundary) (Fastovsky and Sheehan, 2005)

In the 25 years since Alvarez *et al.*, (1980) first proposed that an impact was responsible for the K-T extinctions, stratigraphic and paleoecologic evidence have come together to present a reasonably cohesive picture of a quick demise of the dinosaurs. Evidence from the rates of dinosaur extinction suggests that the extinction was geologically instantaneous; this conclusion in combination with the nature of the post-Cretaceous biologic recovery suggests that the extinction occurred on an extremely short, irresolvable time scale. While the exact killing mechanisms may or may not yet have been identified, all the data—including the rate of extinction, the nature of the recovery, and the patterns of survivorship—are concordant with the hypothesis of extinction by asteroid impact.

- A report on cerebral suppression of sound in the opposite ear in split-brain patients (Milner *et al.*, 1968):

The fact that all the commissurotomy patients were able to report digits presented to the left ear without difficulty, when there was no competing input from the right ear, shows that the ipsilateral pathway could be utilized. The suppression of ipsilateral input in the presence of a competing stimulus from the contralateral ear provides clear behavioral evidence of the dominance of the contralateral auditory projection system in man, a finding for which there is by now considerable



electrophysiological (5) and some behavioral (6) support from work with lower species.

- A report on the effects of three natural agonists on the contraction of smooth muscle in lung airways (Perez and Sanderson, 2005): (SMC = smooth muscle cell)

In conclusion, intrapulmonary airways respond to 5-HT and ACH with a contraction that is maintained by high frequency  $\text{Ca}^{2+}$  oscillations within the SMCs that arise from repetitive cycles of  $\text{Ca}^{2+}$  release and uptake by the SR and require extracellular  $\text{Ca}^{2+}$  for store refilling. By contrast, KCl-induced twitching of SMCs results from low frequency  $\text{Ca}^{2+}$  oscillations produced by an overfilling and uncontrolled release of internal  $\text{Ca}^{2+}$ . Most importantly, the magnitude of the contraction of airway SMCs is regulated by the frequency of the  $\text{Ca}^{2+}$  oscillations.

- A report examining the effect of matrix metalloproteinase inhibitors on healing after periodontal surgery: (BOP = bleeding on probing, ICTP = marker for level of bone resorption, LDD = low dose doxycycline, PD = probing depth) (Gapski *et al.*, 2004)

Six-month administration of LDD suggests that there is an enhanced postsurgical wound healing compared to placebo controls with regard to PD reduction. This positive effect was most marked in deep sites ( $\geq 7$  mm), where the differences in PD reduction were maintained until the completion of the trial. Reductions in the bone resorption marker ICTP were also found in patients while on the drug, suggesting the potential of LDD to act as a bone-sparing agent. In addition, the percentage of BOP sites was affected by LDD therapy, but this effect was only noticeable during the period of the drug administration. Finally, no significant shifts on the periodontal microbiota beyond that attributable to the effects of the surgery could be seen with the utilization of LDD.

- A report examining the ultrasound echogenicity of the substantia nigra in Parkinson's disease: (PD = Parkinson's disease, SN = substantia nigra, TCS = transcranial ultrasound) (Berg *et al.*, 2001)

Our study demonstrates that TCS may serve as a valuable tool in the neuroimaging of PD providing easily available information in addition to other neuroimaging data. Because of the lack of invasiveness and the relatively low cost, it is particularly useful for an application to a large number of patients. Further studies are required to determine whether differences in the echogenicity of the SN in PD patients may display differences in the genetic background or other patho-genetical factors of the disease.

- A report on the cellular processes that bring about healing of finger tip injury in monkeys (Singer *et al.*, 1987):

We conclude that repair of amputated distal digits does not occur in the same manner as in lower vertebrates. Our results confirm earlier reports in the human (see references in Introduction) that the conservative open wound management of patients with such injuries is a satisfactory method which usually produces a cosmetically attractive, normally sensitive and useful digit.

## 2.6. Introduction

### *Skeleton*

- A. Background
  - 1. Currently-Accepted General Statement
  - 2. Available Supporting Data
- B. Gap
- C. Your Plan of Attack

Scientific observations are linked together in a complex network of scientific articles. Like the overwhelming majority of scientific articles, your paper will undoubtedly be deep inside this network and it will be hard to see from the outside.

The Introduction section of your paper leads a reader from a well-known, easily visible landmark into the depths of science and right to the particular spot occupied by your paper. This is the niche where your observations will, hopefully, fit into the collection of all scientific observations.

The Introduction moves from the general to the particular, the opposite direction of the arguments you present in the Discussion.

### 2.6.1. Your Paper Fills a Gap

The background information that you present in your Introduction should show the reader that there is a gap in the current database of science. To reach this gap, start your reader at a well-known landmark, which can be a broad scientific issue, a general observation, or a statement of current thought on the matter. For example:

“Silver staining of neurons began in the 19th century, when Camillo Golgi found that nerve cells have a strong affinity for silver salts.”

Consider the audience of the journal for which you are writing, and begin with a statement that all its readers should know or accept. If the journal is aimed broadly at histologists, for instance, some may not know the relatively specialized Bodian stain and others may not be familiar with the particular problems of staining embryonic axons. Therefore, don't jump immediately into the tangles of your narrow problem with an opening such as “Currently, there is no post-staining intensification procedure that can enhance the Bodian staining of embryonic axons.” Instead, take a moment to orient your readers.

Remind (or educate) your readers about what is known generally. Then describe what is known in the specific area of your research problem. Finally, bring your reader to an edge, an incomplete corner, or a hole in the available scientific reports. Provide sufficient references so that readers can go to the scientific literature and see for themselves exactly what observations currently surround this hole, the gap you propose to fill.



**First Describe the Existing Gap**

After leading your reader to a hole in our knowledge, end your Introduction by stating briefly how you plan to fill the gap. The last few sentences of your Introduction should summarize your plan-of-attack. They should be a variant of the statement: “Here we report the observations that can be seen after doing X,” where ‘X’ is a recipe that is detailed in your Materials and Methods.

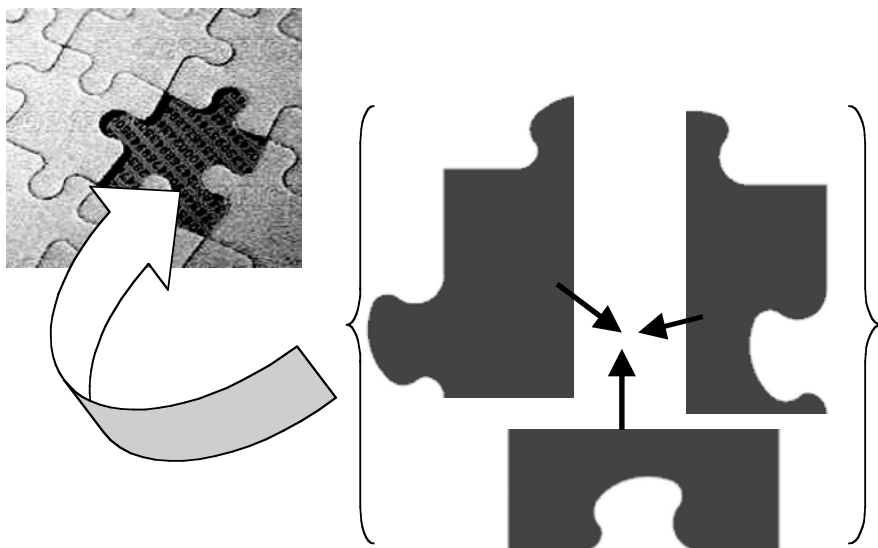

**Then Tell Us How Your Experiments Will End Up Filling the Gap**

**2.6.2. A Sampler of Introductions**

Scientific papers are written about a wide range of subjects and from diverse perspectives. Although all scientific papers should be built using the same basic principles, the particular field and the type of data of each research project shape its paper individually. Here are examples of how a number of scientific writers have used the same basic skeleton to introduce a variety of quite different research projects.

- A report on the role of *juvenile hormone* during the development of moths (Williams, 1961):

*{A. Background*

*1. Currently-Accepted General Statement}*

In the history of every hormone there is a more or less prolonged period when the factor is recognizable only as a certain “activity” within a living system. Progress at this stage is largely dependent on the development of a method of biological assay which is simple, selective, and quantitative.

In the case of the juvenile hormone of insects, the pioneering studies that led to the discovery of the hormone simultaneously directed attention to a method for its assay. This method, as developed by Wigglesworth (1936, 1948, 1958), is performed on mature nymphs of *Rhodnius*. . .

*{2. Available Supporting Data}*

Numerous investigators, following Wigglesworth’s lead, have utilized the “larval assay” in testing the endocrine activity of corpora allata. The literature includes studies of the following genera: *Bombyx* (Bounhiol, 1938; Fukuda, 1944; Ichikawa and Kaji, 1950), *Dixippus* (Pflugfelder, 1939, 1958), *Tenebrio* (Radtke, 1942), *Galleria* (Piepho, 1942, 1950b), *Melanoplus* (Pfeiffer, 1945), *Drosophila* (Vogt, 1946), *Gryllus* (Poisson and Sellier, 1947), *Oncopeltus* (Novak, 1951), and *Calliphora* (Possompes, 1953). The conclusions derived in all these studies have confirmed the fact that the corpora allata undergo substantial changes in activity during the course of metamorphosis.

*{C. Gap}*

At the Harvard laboratory we also have tried to make use of the larval assay in testing for juvenile hormone. A survey of all our experiments during the past fifteen years fails to reveal a single instance in which the implantation of active corpora allata interfered with the transformation of fifth stage *Cecropia* larvae into normal pupae. For reasons that are not fully understood, the larval assay does not work in the case of the *Cecropia* silkworm.

*{D. The Plan of Attack}*

Solution of our problem came from an unexpected direction. As describe in the previous paper of this series, the “pupal assay” was accidentally discovered in 1947; unlike the larval assay, it proved to be an extremely sensitive test for juvenile hormone (Williams, 1952a, 1959).

In the present study the pupal assay has been used as a principal tool in a study of the role of juvenile hormone in the growth and metamorphosis of the *Cecropia* silkworm.

- A report of growth of individual axons and accompanying sheath cells followed in the living animal over periods of days to weeks (Speidel, 1932):

*{A. Background*

*1. Currently-Accepted General Statement}*

While many studies have been made on the growth, development, and regeneration of peripheral nerves, the process of formation of the myelin sheath has never been adequately described.

*{2. Available Supporting Data}*

Nerve cells from spinal ganglion, spinal cord, and brain have been cultivated *in vitro*, and the growth of processes from these has been watched (Harrison, '08, '10; Ingebrigsten, '13; Esaki, '29, and others). Likewise, the movements of the sheath cells of Schwann have been seen.

*{B. Gap}*

No one, however, up to the present time has succeeded in observing the formation of the myelin sheath, either in tissue culture or in a living animal.

*{C. The Plan of Attack}*

Studies of phenomena of degeneration and regeneration in frog tadpoles for the past few years (Speidel, '29) convinced me that it might be feasible to watch the activities of peripheral nerves in the tail-fin expansion of living tadpoles. Preliminary observations showed that the technical difficulties were not too great and that, under favorable conditions, it was possible to keep under observation from day to day the same sheath cells and nerve sprouts for a considerable period of time. This investigation, therefore, was undertaken in an attempt to follow individual sheath cells and nerve sprouts and to correlate their movements with the formation of the myelin sheath.

- A report on the effect on animal diets of S-methylmethionine (SMM), a compound found only in plants: (Met = methionine) (Augsperger *et al.* 2005)

*{A. Background}**1. Currently-Accepted General Statement}*

S-Methylmethionine (SMM) is an analog of S-adenosyl-methionine (SAM; Fig.1), with a methyl group substituted for the adenosyl group. This compound is unique to plants and is found in measurable-to-high concentrations in corn, cabbage, tomatoes, celery, spinach, and garlic (1–3). . .

*{2. Available Supporting Data}*

Previous research elucidated the mechanism for synthetic synthesis and the *in vitro* and *in vivo* metabolism of SMM (7–12). SMM promoted the growth of *Escherichia coli* heterotrophs only in the presence of Cys or Hcy (9). Radiolabeling experiments suggested that the methyl group of SMM is available for choline or creatine synthesis, but not for Met synthesis (13).

*{B. Gap}*

*In vivo* experiments with rats were equivocal, with SMM supporting growth of rats fed sulfur amino acid (SAA)-deficient diets (14, 15), but not in rats fed SAA-free diets (13). Additionally, there is anecdotal evidence for SMM exhibiting choline bioactivity as a result of ameliorating choline deficiency–induced fatty liver in rats (16).

*{C. The Plan of Attack}*

The objective of this research was to qualitatively and quantitatively determine the efficacy of L-SMM for sparing dietary choline or Met. Avians, unlike mammals, have a requirement for preformed choline that cannot be replaced by excess Met (17, 18), making them an excellent animal model for studying choline bioavailability.

- A report on the effects of three natural agonists on the contraction of smooth muscle in lung airways (Perez and Sanderson, 2005):

*{A. Background}**1. Currently-Accepted General Statement}*

Gas exchange in the lungs requires an appropriate matching of ventilation to blood perfusion and this is influenced by the caliber of the airways and blood vessels. Consequently, an understanding of the mechanisms that control the size of airways and arterioles is required to understand lung physiology and the development of obstructive lung disease and pulmonary hypertension.

*{2. Available Supporting Data}*

In general, the mechanisms that control the caliber of intrapulmonary airways or arterioles have been investigated in either whole lungs or isolated smooth muscle cells (SMCs).

*{B. Gap}*

While these approaches provide valuable data, it is difficult to determine the site or size of airway or arteriole contraction by measurements of air flow in whole lungs or blood pressure in the pulmonary artery. Similarly, it is difficult to relate changes in intracellular  $\text{Ca}^{2+}$  concentration ( $[\text{Ca}^{2+}]_i$ ) of isolated SMCs to the contractile responses of intact airways and arterioles.

*{C. The Plan of Attack}*

Our solution to investigate how cellular physiology regulates the contraction of the small airways or arterioles was to examine living lung slices that retain many structural and functional properties of the lung. Relatively thick lung slices have been used to study the contractile response of airways (Dandurand *et al.*, 1993; Martin *et al.*, 1996; Minshall *et al.*, 1997; Adler *et al.*, 1998; Duguet *et al.*, 2001; Martin *et al.*, 2001; Wohlsen *et al.*, 2001), but thinner lung slices, combined with confocal microscopy, provided us with the ability to study changes in  $[\text{Ca}^{2+}]_i$  of SMCs that underlie airway contraction (Bergner and Sanderson, 2002a,b, 2003).

- A report on using high doses of cytosine arabinoside (ARA-C) to keep patients with acute myeloid leukemia (AML) in continuous complete remission (CCR) (Bohm *et al.*, 2005):

*{A. Background}**1. Currently-Accepted General Statement}*

In response to induction chemotherapy with cytarabine and an anthracycline, the majority (70–80%) of all patients with de novo acute myeloid leukemia (AML) aged less than 60 years enter complete hematologic remission (CR) [1–4]. However, without further postremission treatment, recurrence of disease is likely to occur. Thus, it is generally appreciated that postremission therapy is important to maintain CR in patients with AML [1–5]. Using ‘standard dose chemotherapy’ for consolidation, only 25% of these patients achieve a long lasting (continuous) complete remission [6, 7]. Therefore, alternative strategies of postremission therapy have been proposed. A straightforward approach is allogeneic stem cell transplantation from a sibling donor [8, 9]. However, this procedure is restricted to younger patients with a suitable donor. For those patients who cannot be transplanted, consolidation protocols employing high doses of ARA-C (monotherapy or in combination with other cytostatic drugs) or autologous stem cell transplantation are usually considered as appropriate therapy [10–15].

In 1994, the Cancer and Leukemia Group B (CALGB) published a high dose ARA-C-based consolidation regimen. This regimen (HiDAC) consists of repetitive (up to four) cycles of high dose ARA-C ( $3 \text{ g/m}^2$ ) given twice on days 1, 3, and 5 [16]. In this particular CALGB study trial, HiDAC was found to represent an effective consolidation. Thus, the rates of leukemia-free survival were similar to those achieved with high dose chemotherapy and consecutive autologous stem cell transplantation [16]. In addition, the HiDAC protocol was reported as a relatively safe approach with moderate side effects in patients aged less than 60 years, and a low rate of treatment-related deaths.

*{2. Available Supporting Data}*

Despite the apparent efficiency and relatively low rate of side effects, only a few studies have confirmed the value of high dose cytarabine as postremission treatment in patients with AML so far [14, 17, 18].

*{B. Gap}*

However, these studies did not follow exactly the protocol published by the CALGB.

*{C. The Plan of Attack}*

We here present the outcome of 44 patients with AML treated with up to four cycles of HiDAC in a single center.

- A report measuring the interface tensions in immiscible fluid mixtures as the fluid boundaries disappear (Sundar and Widom, 1987):

*{A. Background}*

*1. Currently-Accepted General Statement}*

One of the striking features of the approach to a critical point of the equilibrium of two fluid phases is the disappearance of the interface between them and the vanishing of the associated interfacial tension. In the case of an ordinary critical point, for example that of the liquid-vapor equilibrium of a simple fluid or the liquid-liquid equilibrium of a partially miscible binary mixture, the interfacial tension  $s$  is known to vanish on approach to the critical point as (ref. 1)

$$s \sim (T(c) - T)^u$$

where  $T$  is the temperature and  $T(c)$ , the critical temperature, with  $u \simeq 1.26$ .

The work described here addresses the corresponding question of the behavior of the interfacial tensions, and, in particular, the value of the exponent  $u$ , on approaching a tricritical point of the equilibrium of three liquid phases in a quaternary system.

...

*{2. Available Supporting Data}*

...the expectation from theory is that  $s \sim (T(t) - T)^u$  with  $u = 2$  and  $T(t)$  the tricritical temperature. This result follows from the van der Waals theory of the interface (ref. 4), with the free energy in the three-phase region near the tricritical point as given by Griffiths (ref. 5). This value of  $u$  is thus expected to differ from the  $u = 1.26$  associated with an ordinary critical point of two-phase equilibrium.

The prediction of  $u = 2$  was independently made (ref. 6) for the tricritical point that occurs in mixtures of  $^3\text{He}$  and  $^4\text{He}$  and has been verified experimentally there (ref. 7).

This problem has also been studied in the context of the tricritical point that occurs in quasibinary mixtures of ethane + (n-octadecane + n-nonadecane) (ref. 8). There, an exponent that from theory is expected to be  $(2/3)u$  was found to vary from about 1.26 to 1.4 for different paths of approach to the tricritical point. That would correspond to a variation of  $u$  in the range 1.9 to 2.1. While a value in that range is in fairly good agreement with the theoretical value of 2, the variability is not understood.

*{B. Gap}*

While no experiments have been reported on systems of four or more components with the aim of determining  $u$ , the results of surface tension measurements on brine + hydrocarbon + surfactant systems with a series of surfactants, at a single temperature, have been combined and the results, if suitably interpreted, shown again to be consistent with  $u = 2$  (ref. 9).

*{C. The Plan of Attack}*

The system chosen for study here was the quaternary mixture ammonium sulfate + water + ethanol + benzene. The phase diagram for this system in the region of three-liquid-phase equilibrium near the tricritical point has been studied in detail (ref. 2) and the tricritical temperature determined to be  $49^\circ\text{C}$ .

At each of a few different temperatures, the interfacial tensions  $s(a,b)$  and  $s(b,c)$  were determined for several overall compositions. These were then used to obtain the quantities  $s(0)(T)$  and  $s((a, b), c)(T)$  defined above.

- A report on the aging changes of Au/n-AlGa<sub>1-x</sub>N Schottky diodes when exposed to air (Readinger and Mohney, 2004):

*{A. Background}*

*1. Currently-Accepted General Statement}*

The variable Al-Ga composition of n-type Al(x)Ga(1-x)N provides new device structures and device capabilities unobtainable with n-GaN alone. High-quality Schottky barriers to n-type AlGa<sub>1-x</sub>N are important for the efficient operation of ultraviolet photodetectors or heterostructure field-effect transistors (HFETs) (1-4).

*{2. Available Supporting Data}*

Several publications report the barrier height for Schottky contacts to n-AlGa<sub>1-x</sub>N (5-13), including three studies of the influence of the Al mole fraction on the barrier height (8, 11, 12) where the increase in Al mole fraction ( $x < 0.35$ ) provides higher Schottky barriers over those of pure n-GaN. Other more recent publications report on the thermal stability of Schottky barriers for gate metallizations on HFETs (11, 14-22). All of these studies were carried out on n-Al(x)Ga(1-x)N with  $0 \leq x \leq 0.35$ , with a wide range of barrier heights reported (0.45-1.55 eV), similar to the case for n-GaN.

*{B. Gap}*

We had originally intended to only study the electrical characteristics of Schottky contacts to n-AlGa<sub>1-x</sub>N as prepared using different wet-chemical pre-metallization



surface treatments. However, we found instead that another variable much more dramatically influenced the performance of Schottky contacts to n-AlGaIn (23). In these studies, it was found that the measured Schottky barrier characteristics were not stable with time when exposed to air at room temperature. In fact, we observed a significant change in the electrical characteristics as barrier heights increased, ideality factors decreased, and reverse leakage currents were reduced after only hours or days.

*{C. The Plan of Attack}*

In this paper, we summarize our previous work and present new studies of the environmental aging of Schottky barriers. A summary of our findings as well as the proposed mechanism shall also be presented.

- A report on the cellular processes that bring about healing of finger tip injury in monkeys (Singer *et al.*, 1987):

*{A. Background}*

*1. Currently-Accepted General Statement}*

The ability of lower vertebrates, such as fish, newts or salamanders, to regenerate body parts missing either by accident or by deliberate alteration in the laboratory is well known

*{2. Available Supporting Data}*

(Wallace 1981; Geraudie and Singer 1984). These animals can replace an amputated extremity (limb or fin) with a new distal structure of normal morphology and function. Two factors have been shown to be of great importance in the initiation of the regrowth of the body parts in these lower forms. The first factor is the necessity for a fresh wound surface which soon will be covered by a pluristratified epidermal epithelium originating from the margins of the amputation site (Repech and Oberpriller 1978; Stocum 1985). Suturing of the amputation site as well as repeated removal of the epidermal regenerating cover prevents regrowth (Thornton 1957, 1968; Singer 1980).

The second requirement involves the presence of an adequate nerve supply at the wound surface met either by motor or sensory axons (Singer 1946, 1952, 1974). The regeneration process after epidermal wound healing consists of an accumulation of cells, the origin of which has excited controversy in the past (Wallace 1981). Nevertheless, recent work using a monoclonal antibody to an intracellular antigen specific for a subpopulation of blastemal cells supports the hypothesis that blastemal cells could arise by a process of dedifferentiation of the stump tissues, especially muscles and Schwann cells, as shown by Brookes's study (1984). The accumulation phase is followed by the differentiation phase when cells begin to differentiate and reconstruct the limb tissues: cartilage giving way to endochondral bone, muscles, and connective tissue invaded by blood vessels and nerves emerging from the stump.

*{B. Gap}*

The regenerative capacity of lower vertebrates to replace perfectly an amputated extremity was thought to be nonexistent in higher vertebrates, including man. In recent years, however, the open wound treatment of finger tip injuries has given

very satisfactory results according to numerous authors (Bojsen-Moller *et al.*, 1961; Holm and Zachariae 1974; Illingworth 1974; Bosley 1975; Farrell *et al.*, 1977; Fox *et al.*, 1977; Rosenthal *et al.*, 1979; Louis *et al.*, 1980; Chow and Ho 1982) which has also been the experience of one of the authors (ECW) in a small number of cases (unpublished results). In fact, the repair has been so good especially in small children that the question arises whether this might actually be regeneration similar to that just described for lower forms of life. In fact, in mammals, mice have been shown to regrow the extremity of an amputated toe (Neufeld 1980; Borgens 1982). Consequently, in order to study this problem, we decided to test it on the Rhesus monkey, a mammal closer to humans.

*{C. The Plan of Attack}*

In this paper, we report our results of the repair process following digital amputation of digits in the above animal. The data deals with the study of the morphology and histology of regrowth and quantification of innervation in amputated digit tips studied with histological silver nerve impregnation and counting of cross-sectioned axons.

### 2.6.3. An Example of a Complete Introduction

#### Introduction

Silver staining of neurons began in the 19th century, when Camillo Golgi found that nerve cells have a strong affinity for silver salts. By 1880, he had modified Louis Daguerre's 1839 recipes for developing silver iodide photographs and had created a silver stain for fixed neural tissue. Golgi's silver stain cleanly highlights the full three-dimensional arborization of the axon and dendrites of individual neurons. With Golgi's stain, Santiago Ramon y Cajal (1928) mapped the cellular architecture of a wide variety of nervous systems. His comprehensive silver stain studies remain the foundation of neuroanatomy (Santini 1975, Parent 1996).

In the 1930's, David Bodian developed a silver staining recipe that was easier and more consistent than earlier methods (Bodian 1936). The Bodian stain has a high and specific affinity for the intracellular neurofilament proteins (Gambetti *et al.*, 1981, Phillips *et al.*, 1983), and Bodian staining can be used to trace individual axons through thick tissue sections with a light microscope (e.g. Katz and Lasek 1981). Loots *et al.*, (1979) and Rager *et al.*, (1979) review many of the useful modifications of Bodian's original stain recipe.

Embryonic and immature axons have thin neurofilament bundles. None of the Bodian staining techniques blacken small bundles of neurofilaments sufficiently to be resolved cleanly with light microscopy. For this reason, the Bodian silver stains have not been useful for studies of the earliest stages of nervous system development or the fine details of axons growing in tissue culture. Here, we report a simple post-staining intensifier that enhances the standard Bodian stain and allows young axons and tiny cell processes to be clearly visible using light microscopy.

## 2.7. Title

### *Skeleton*

#### Complete Summary in Two Lines or Less

Each scientific paper needs a Title and an Abstract. Together they form a small scientific report of their own. The combination is used as a stand-in for the complete article in condensed data bases, such as *Biological Abstracts* and *Medlines*.

By itself, the Title is the ultimate précis of your paper, so fill it with clear and useful information. Write:

“Intensifier For Bodian Staining of Tissue Sections and Cell Cultures”

not the mysterious:

“What Can Intensification Add to Bodian Stains?”

or the empty:

“A New Way To Stain Nerve Cells”

Titles, alone, are often used for indexing articles, therefore you should build your Title from words that fully characterize your paper. Begin with a list of the four or five terms that embody the essence of your experiments and observations. Include in this list the *key variables* that are the focus of your experiment. Then arrange the words of your list into a complete phrase.

Some useful rules for title-building include:

- Try to limit your title to two lines of text.
- Use the present tense.
- Use no more than three modifiers for any one noun. Write “Large red Guatemalan tarantulas have 7 stripes” not “Large red 7-striped Guatemalan tarantulas are the most common variety.”

The Title should tell what is in the paper. Here are examples of straight-forward, explanatory Titles from a wide variety of scientific papers:

“The Atomic Weight of Lead of Radioactive Origin”

“Subcutaneous Tri-Block Copolymer Produces Recovery from Spinal Cord Injury”

“The Localization of the Presumptive Cerebral Regions in the Neural Plate of the Axolotl Larva”

“Lateralized Suppression of Dichotically Presented Digits After Commissural Section in Man”

“Dietary S-Methylmethionine, a Component of Foods, has Choline-Sparing Activity in Chickens”

“Evidence from Proton Magnetic Resonance Spectroscopy for a Metabolic Cascade of Neuronal Damage in Shaken Baby Syndrome”

“RBP-J (CSL) is Essential for Activation of the K14/vGPCR Promoter of Kaposi’s Sarcoma-Associated Herpesvirus by the Lytic Switch Protein RTA”

“Studies of Living Nerves. I. The Movements of Individual Sheath Cells and Nerve Sprouts Correlated with the Process of Myelin-Sheath Formation in Amphibian Larvae”

“The Frequency of Calcium Oscillations Induced by 5-HT, ACH, and KCl Determine the Contraction of Smooth Muscle Cells of Intrapulmonary Bronchioles”

## 2.8. Abstract

### *Skeleton 1—Simple Abstract*

One Paragraph: “We did. We saw. We concluded.”

### *Skeleton 2—Abstract with Subsections*

- A. One or Two Sentence BACKGROUND
- B. Two or Three Sentence METHODS
- C. Less Than Ten Sentence RESULTS
- D. One Sentence CONCLUSION

The Abstract presents the essence of your Methods, your Results, and your Conclusion. In your Abstract, write simply: “We did. We saw. We concluded.” Specifically, state the background of or the reason for your study, tell what methods you used, list your main findings, and end with your conclusion. Write your Abstract in complete sentences, and don’t use technical abbreviations without their definitions. It is unusual to cite references in an Abstract.

Try to write a lean Abstract. The Abstract should be bare—a short, plain paragraph listing your core findings and stating the one or two main points of your paper.

Some journals ask that you follow your Abstract with a list of 3–10 key words or phrases. These terms will be used to cross-index your article under standard headings in large data bases. Therefore, besides choosing key words specific to your paper, include some terms that categorize your paper more generally. For example, a paper on the number of dorsal stripes on Guatemalan tarantulas might have these key words:

“Key Words: Central American spiders, tarantulas, Guatemalan arthropods, coloration of spiders, dorsal stripes”

### 2.8.1. A Simple Abstract

Scientific journals use two different forms for their Abstracts. Traditional journals use a simple Abstract—an undifferentiated paragraph of less than 200 words. For example:

**ABSTRACT.** Intensifying Bodian-stained fixed cells and tissues with a photographic enhancing solution reveals immature axons and small cell processes. With post-staining intensification, the fine details of growth cones in tissue culture can be seen clearly with light microscopy.

Here are a number of well-written simple Abstracts that fully but succinctly report “We did. We saw. We concluded.”

- A report on using high doses of cytosine arabinoside (ARA-C) to keep patients with acute myeloid leukemia (AML) in continuous complete remission (CCR) (Bohm *et al.*, 2005)

#### **Abstract**

High dose intermittent ARA-C ( $2 \times 3\text{g}/\text{m}^2$  i.v., days 1, 3, 5) = HiDAC was introduced as consolidation in AML by the CALGB-group in 1994. We treated

44 de novo AML patients in CR with up to four cycles of HiDAC (four cycles: 56.8%; three cycles: 22.7%; two cycles: 6.8%; one cycle: 13.7%). Median duration of aplasia ( $ANC < 0.5 \times 10^9/l$ ) was 12 days. Neutropenic fever occurred in 38.6% of the patients during the first, 52.6% during the second, 45.7% during the third, and in 40% during the fourth cycle. Non-hematologic toxicity was tolerable. The median overall- and disease-free survival were 19.3 and 11.3 months, respectively. The best outcome was seen in patients aged  $<40$  years. These results confirm that HiDAC is a safe and effective consolidation in AML.

**Key Words:** AML; Consolidation chemotherapy; High dose ARA-C; Toxicity

- A report on cerebral suppression of sound in the opposite ear in split-brain patients (Milner *et al.*, 1968):

**Abstract.** Right-handed patients with surgical disconnection of the cerebral hemispheres cannot report verbal input to the left ear if different verbal stimuli have been channeled simultaneously to the right ear. With monaural stimulation, they show equal accuracy of report for the two ears. These findings highlight the dominance of the contralateral over the ipsilateral auditory projection system. Suppression of right-ear input is obtained in nonverbal tests. Dissociation between verbal and left-hand stereognostic responses indicate a right-left dichotomy for auditory experience in the disconnected hemispheres.

- A report on the effect on animal diets of S-methylmethionine, a compound found only in plants (Augsburger *et al.*, 2005):

**ABSTRACT** Acid hydrolysis of dehulled soybean meal (SBM) and corn gluten meal (CGM) followed by chromatographic amino acid analysis (ninhydrin detection) revealed substantial quantities of S-methylmethionine (SMM) in both ingredients (1.65g SMM/kg SBM; 0.5g SMM/kg CGM). Young chicks were used to quantify the methionine-(Met) and choline-sparing bioactivity of crystalline L-SMM, relative to L-Met and choline chloride standards in 3 assays. A soy isolate basal diet was developed that could be made markedly deficient in Met, choline, or both. When singly deficient in choline or in both choline and Met, dietary SMM addition produced a significant ( $P < 0.01$ ) growth response. In Assay 2, dietary SMM did not affect ( $P > 0.10$ ) growth of chicks fed a Met-deficient, choline-adequate diet. A standard-curve growth assay revealed choline bioactivity values (wt:wt) of  $14.2 \pm 0.8$  and  $25.9 \pm 5.1$  g/100 g SMM based on weight gain and gain:food responses, respectively. A fourth assay, using standard-curve procedures, showed choline bioactivity values of  $20.1 \pm 1.1$  and  $22.9 \pm 1.7$  g/100 g SMM based on weight gain and gain:food responses, respectively. It is apparent that SMM in foods and feeds has methylation bioactivity, and this has implications for proper assessment of dietary Met and choline requirements as well as their bioavailability in foods and feeds.

**KEY WORDS:** choline, methionine, S-methylmethionine, betaine, chick

- A report of improvements to a model of the release kinetics of solute from a polymeric matrix, with experimental tests of the improved model (Paul and McSpadden, 1976):

The theory of diffusional release of a solute from a polymeric matrix where the initial loading of solute is less than or greater than the solubility limit has been reviewed and extended. The conceptual model for the saturated case proposed by Higuchi has been refined to remove the inaccuracies caused by the “pseudosteady-state” assumption. A finite external mass transfer resistance has also been incorporated into the present analysis. For all solute loadings, the asymptotic release profile is seen to be a linear plot of total amount of solute released versus the square-root of time which has a finite intercept on the square-root of time axis because of the external resistance. The dependence of the slope and intercept on solute loading and other system parameters can be predicted for all cases with the models presented. Experimental release rates of an organic dye from a silicone polymer into acetone were measured for a range of solute loadings in order to test the applicability of these equations. All system parameters except the external mass transfer coefficient were measured by independent experiments. The experimental release data were described very well by the computed results.

- A report examining the ultrasound echogenicity of the substantia nigra in Parkinson’s disease (Berg *et al.*, 2001)

**Abstract** Recently an increased echogenicity of the substantia nigra (SN) in patients with Parkinson’s disease (PD) was demonstrated by transcranial ultrasound (TCS). In this study we set out to compare SN echogenicity with disease characteristics (time of onset, duration, toxin exposure) in a large patients sample. Patients’ history and exposure to toxins were recorded from 112 PD patients who underwent a thorough neurological examination including assessment of disease stage according to Hoehn and Yahr and CURS (Columbia University Rating Scale). Personality was assessed according to the Freiburg Personality Inventory. In all patients the area of SN echogenicity was encircled and measured by TCS. All except 9 patients had hyperechogenic SN areas exceeding the mean plus standard deviation values of an age matched control group ( $0.19 \text{ cm}^2$ ). The age of disease onset was lower in patients who displayed an area of SN echogenicity above this value. The area of SN echogenicity was larger contralateral to the side with more severe symptoms. None of the other characteristics correlated with ultrasound findings. We conclude that SN hyperechogenicity is a typical finding in PD. The cause of hyperechogenicity is so far unknown. Investigation of the underlying reason might disclose a pathogenic factor in PD.

**Key words:** Parkinson’s disease, Transcranial ultrasound, Substantia nigra hyperechogenicity, Vulnerability marker

- A report on the effects of three natural agonists on the contraction of smooth muscle in lung airways (Perez and Sanderson, 2005):

**ABSTRACT** Increased resistance of airways or blood vessels within the lung is associated with asthma or pulmonary hypertension and results from contraction of smooth muscle cells (SMCs). To study the mechanisms regulating these contractions, we developed a mouse lung slice preparation containing bronchioles and

arterioles and used phase-contrast and confocal microscopy to correlate the contractile responses with changes in  $[Ca^{2+}]_i$  of the SMCs. The airways are the focus of this study. The agonists, 5-hydroxytryptamine (5-HT) and acetylcholine (ACH) induced a concentration-dependent contraction of the airways. High concentrations of KCl induced twitching of the airway SMCs but had little effect on airway size. 5-HT and ACH induced asynchronous oscillations in  $[Ca^{2+}]_i$  that propagated as  $Ca^{2+}$  waves within the airway SMCs. The frequency of the  $Ca^{2+}$  oscillations was dependent on the agonist concentration and correlated with the extent of sustained airway contraction. In the absence of extracellular  $Ca^{2+}$  or in the presence of  $Ni^{2+}$ , the frequency of the  $Ca^{2+}$  oscillations declined and the airway relaxed. By contrast, KCl induced low frequency  $Ca^{2+}$  oscillations that were associated with SMC twitching. Each KCl-induced  $Ca^{2+}$  oscillation consisted of a large  $Ca^{2+}$  wave that was preceded by multiple localized  $Ca^{2+}$  transients. KCl-induced responses were resistant to neurotransmitter blockers but were abolished by  $Ni^{2+}$  or nifedipine and the absence of extracellular  $Ca^{2+}$ . Caffeine abolished the contractile effects of 5-HT, ACH, and KCl. These results indicate that (a) 5-HT and ACH induce airway SMC contraction by initiating  $Ca^{2+}$  oscillations, (b) KCl induces  $Ca^{2+}$  transients and twitching by overloading and releasing  $Ca^{2+}$  from intracellular stores, (c) a sustained,  $Ni^{2+}$ -sensitive, influx of  $Ca^{2+}$  mediates the refilling of stores to maintain  $Ca^{2+}$  oscillations and, in turn, SMC contraction, and (d) the magnitude of sustained airway SMC contraction is regulated by the frequency of  $Ca^{2+}$  oscillations.

**KEY WORDS:** laser scanning, confocal microscopy, asthma, airways, arterioles, mouse lung slices

### 2.8.2. An Abstract with Subsections

Other journals use abstracts that are miniatures of the actual paper. These Abstracts are usually longer (200–350 words) and are written in subsections that parallel the article. Typically, the subsections are:

<b>BACKGROUND (CONTEXT, OBJECTIVE)</b>	<b>= 1–2 sentences</b>
<b>METHODS (METHODOLOGY)</b>	<b>= 2–3 sentences</b>
<b>RESULTS</b>	<b>= &lt;10 sentences</b>
<b>CONCLUSION</b>	<b>= 1 sentence</b>

These subsections are brief summaries of the paper's:

#### **Introduction**

#### **Materials and Methods**

#### **Results**

#### **Discussion and Conclusion.**

For example:

ABSTRACT. **BACKGROUND:** The Bodian silver stain for neurons does not cleanly stain fine cell processes such as embryonic axons in situ and growing neurites in tissue culture. **METHODS:** We used a modified photographic enhancement



procedure as a post-staining intensifier for the standard Bodian technique. **RESULTS:** Intensifying Bodian-stained fixed tissues cleanly highlighted small embryonic tadpole axons in spinal cord sections. In embryonic chick cell cultures, details of thin neurites and their growth cones were visible. **CONCLUSION:** With post-staining intensification of the Bodian silver stain, the fine details of immature axons can be seen clearly with light microscopy.

From the scientific literature, here are two examples of well-written Abstracts with Subsections:

- A report on the use of proton magnetic resonance spectroscopy to assess the severity of damage in a shaken infant (Haseler *et al.*, 1997):

**ABSTRACT.** *Objective.* The purpose of this study was to use proton magnetic resonance spectroscopy (MRS) as a metabolic assay to describe biochemical changes during the evolution of neuronal injury in infants after shaken baby syndrome (SBS), that explain the disparity between apparent physical injury and the neurological deficit after SBS.

*Methodology.* Three infants [6 months (A), 5 weeks (B), 7 months (C)] with SBS were examined repeatedly using localized quantitative proton MRS. Examinations were performed on days 7 and 13 (A), on days 1, 3, 5, and 12 (B), and on days 7 and 19 (C) posttrauma. Long-term follow-up examinations were performed 5 months posttrauma (A) and 4.6 months posttrauma (B). Data were compared to control data from 52 neurologically normal infants presented in a previous study.

*Results.* Spectra from parietal white matter obtained at approximately the same time after injury (5 to 7 days) showed markedly different patterns of abnormality. Infant A shows near normal levels of the neuronal marker *N*-acetyl aspartate, creatine, and phosphocreatine, although infant C shows absent *N*-acetyl aspartate, almost absent creatine and phosphocreatine, and a great excess of lactate/lipid and lipid. Analysis of the time course in infant B appears to connect these variations as markers of the severity of head injury suffered in the abuse, indicating a progression of biochemical abnormality. The principal cerebral metabolites detected by MRS that remain normal up to 24 hours fall precipitately to 40% of normal within 5 to 12 days, with lactate/lipid and lipid levels more than doubling concentration between days 5 and 12. *Conclusions.* A strong impression is gained of MRS as a prognostic marker because infant A recovered although infants B and C remained in a state consistent with compromised neurological capacity. Loss of integrity of the proton MRS spectrum appears to signal irreversible neurological damage and occurs at a time when clinical and neurological status gives no indication of long-term outcome. These results suggest the value of sequential MRS in the management of SBS.

**KEY WORDS:** shaken baby syndrome, traumatic brain injury, neuronal injury, magnetic resonance imaging, magnetic resonance spectroscopy.

- A report examining the effect of matrix metalloproteinase inhibitors on healing after periodontal surgery (Gapski *et al.*, 2004):

**Background:** The adjunctive use of matrix metalloproteinase (MMP) inhibitors with scaling and root planing (SRP) promotes new attachment in patients with periodontal disease. This pilot study was designed to examine aspects of the biological response brought about by the MMP inhibitor low dose doxycycline (LDD) combined with access flap surgery (AFS) on the modulation of periodontal wound repair in patients with severe chronic periodontitis.

**Methods:** Twenty-four subjects were enrolled into a 12-month randomized, placebo-controlled, double-masked trial to evaluate clinical, biochemical, and microbial measures of disease in response to 6 months therapy of either placebo capsules + AFS or LDD (20 mg b.i.d.) + AFS. Clinical measures including probing depth (PD), clinical attachment levels (CAL), and bleeding on probing (BOP) as well as gingival crevicular fluid bone marker assessment (ICTP) and microbial DNA analysis (levels and proportions of 40 bacterial species) were performed at baseline and 3, 6, 9, and 12 months.

**Results:** Patients treated with LDD + AFS showed more potent reductions in PD in surgically treated sites of >6 mm ( $P < 0.05$ , 12 months). Furthermore, LDD + AFS resulted in greater reductions in ICTP levels compared to placebo + AFS. Rebounds in ICTP levels were noted when the drug was withdrawn. No statistical differences between the groups in mean counts were found for any pathogen tested.

**Conclusions:** This pilot study suggests that LDD in combination with AFS may improve the response of surgical therapy in reducing probing depth in severe chronic periodontal disease. LDD administration also tends to reduce local periodontal bone resorption during drug administration. The use of LDD did not appear to contribute to any significant shifts in the microbiota beyond that of surgery alone.

**KEY WORDS:** bone resorption/prevention and control; doxycycline/therapeutic use; periodontal attachment; periodontal diseases/therapy; surgical flaps.

## 2.9. References

### *Skeleton*

List of All Sources Cited in the Paper Using the Appropriate Bibliographic Format

The References section names the links through which your paper is tied into the web of science.

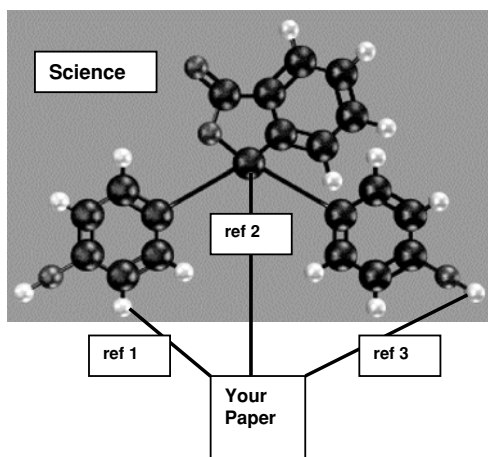

These links should be listed in a standardized bibliographic format at the end of your paper.

### 2.9.1. Include a Range of Original Sources

The References section comes after the Conclusion and the Acknowledgements. A thorough bibliography includes citations to background information, the sources of your experimental techniques, documentations of similar observations, and discussions of related empirical rules and theories.

Writing the References is an opportunity to be sure you have dug into the relevant literature. When you are piecing together your list of citations, do some extra library work. Use the extensive bibliographic search power of the Internet. And remember to look for contrasting as well as supportive reports.

Always try to cite original sources. Summaries in review articles or books cannot include all the original data, with its quirks, qualifiers, and special cases. Summary articles frequently miss important information, and sometimes they even get the facts wrong. For you, broad reference articles are best used as annotated lists of original scientific reports. Go and read the first-hand accounts for yourself. Then make your reference list tight and deep, rather than overly broad, by citing only sources that relate directly to your arguments.

### 2.9.2. Appropriate Bibliographic Format

There are two formats used for the citations of each item in your reference list.

- The full citation of each item belongs in the References section of your paper. This citation is written in a standard bibliographic format, such as:

“Katz MJ 1983 Comparative anatomy of the tunicate tadpole, *Ciona intestinalis*. Biol Bull 164: 1-27.”

- All items in your References section must be referred to elsewhere in the paper. These text citations also use a standard format, such as:

“(Katz 1983)”

The exact styles of these two citation formats vary from journal to journal, so consult the Information for Contributors section of your target journal. Many medicine-related journals use the same formats, the *Uniform Requirements for Manuscripts Submitted to Biomedical Journals*, which are available online at [www.icmje.org](http://www.icmje.org). In the special cases of theses and dissertations, follow the formats in Turabian, KL, 1996, *A Manual for Writers of Term Papers, Theses, and Dissertations*, 6th edition, University of Chicago Press, Chicago, IL. Additional style manuals are listed in Appendix E below, and samples of typical bibliographic formats are listed in Appendix D.

### 2.9.3. Matching the References List to the Text Citations

As you rearrange and rewrite your manuscript, the text citations will get pushed around, changed, and dropped. Therefore, after you finish polishing your manuscript, take a few minutes to check the text citations. Make sure that each of the bibliographic entries in the References is still cited somewhere in the text or the figure legends.

With a copy of the References section in hand, go through the manuscript from beginning to end. When a bibliographic entry is referred to, mark it on your copy of the References. In the end, delete any bibliographic entries not cited in your paper.

## 2.10. Footnotes

### *Skeleton*

#### A Superscript Number Followed By One Brief Paragraph

For most journals (*Science* is the prominent exception), footnotes are a minor part of their scientific articles.

In your paper, use footnotes only for information that is not necessary for your presentation. If your paper is incomplete without a certain fact, reference, or comment, then that item belongs in the main text.

Sometimes, however, there are bits of information that you would like to record for readers who will be going off on a tangent from your paper. Put these nuggets in footnotes. For example:

“<sup>1</sup>Like most members of the sunflower family, our hybrid *Rudbeckia* produces flowers with yellow petals. At the 2002 World Congress of Sunflower Growers, Prof. Max Katz-Breit of the University of Ostrow reported in the keynote lecture that he had grown the first known blue *Rudbeckia*.”

Each footnote must be cited in the body of the text, and number the footnotes in the order in which they are cited. For your final manuscript, list all footnotes on a separate page (titled “Footnotes”) at the very end of the paper.

Here is an example of a tangential comment appropriately put into a footnote in a classic scientific paper (Richards and Lembert 1914).

[3]Mr. Max E. Lembert, Dipl. Ing., a pupil of Dr. Fajans, was sent by him and the Technische Hochschule of Karlsruhe, with the support of Professor Bredig, to Harvard University especially for this purpose. Sir William Ramsay, also, at about the same time, had urged on behalf of Dr. Soddy that the atomic weight of radioactive lead should be studied in the Wolcott Gibbs Memorial Laboratory. It is needless to say that the opportunity was welcomed; indeed, the matter would have been taken up here before, except for a fear of trespassing upon a field which might properly be considered as belonging to the proposers of the theory. A brief announcement of this work was made by Dr. Fajans at the meeting of the Bunsen Gesellschaft in Leipzig on May 21st, and a brief notice was published in “Science” on June 5, 1914.

## 2.11. Acknowledgements

### *Skeleton*

One short Paragraph

When your paper is finished, add one last historical note, the Acknowledgements. This is a paragraph that usually comes after your Conclusion and before the References. The Acknowledgements is a special addendum to the Materials and Methods. In simple, complete sentences, record those who gave you advice, information, assistance, and materials. Be sure to list all your sources of financial support.

The Acknowledgements are almost entirely in your hands. Here are some examples to illustrate the range of Acknowledgements found in the scientific literature.

“I desire to express my thanks to Mr. William Kay for his invaluable assistance in counting scintillations.”

“This study was supported, in part, by Grant RG-5920 from the National Institutes of Health.”

“This work was made possible by a grant from the Nuffield Foundation, for which we should like to express our gratitude. Our thanks are also due to Professor J.Z. Young for his criticism of the manuscript.”

“We thank D. Wang, Y.T. Liu, and A. Urisman for their technical assistance on the microarrays. B. Glaunsinger is supported by an American Cancer Society post-doctoral fellowship, and D. Ganem is a member of the Howard Hughes Medical Institute. The authors have no conflicting financial interests.”

“Grateful thanks are due to J.D. Archibald, D.A. Eberth, K. Howard, J.A. Lillegraven, G.J. Retallack, and A. Sweet, all of whom reviewed earlier drafts of this manuscript and contributed immensely to its improvement. However, the viewpoints expressed here are not necessarily those of the reviewers. This work was supported in part by the Instituto de Geología, Universidad Nacional Autónoma de México, and by a Fulbright Garcia-Robles Award.”

“This study was supported by the Fonds zur Forderung der Wissenschaftlichen Forschung in Osterreich (FWF) grant #P-14031. *Contributions.* Alexandra Bohm contributed to collection, analysis and interpretation of data and drafting of the article, Maria Piribauer contributed to data collection and assembly, Friedrich Wimazal contributed to collection of data, Klaus Geissler contributed patients and logistic support, Heinz Gisslinger contributed patients as well as administrative support, Paul Knobl contributed patients and administrative support, Ulrich Jager contributed patients and administrative as well as logistical support, Christa Fonatsch contributed analysis and interpretation of cytogenetics, Paul A. Kyrle contributed patients and logistical support, Peter Valent contributed to the conception and design of the study, interpretation of data, drafting, and final approval, Klaus Lechner contributed administrative and logistical support and critical revision of the article, Wolfgang R. Sperr contributed conception and design of the study, statistical analysis and interpretation of data as well as drafting and final approval of the article.”

## Chapter 3

# PREPARING TO PUBLISH

### 1. GESTATION AND REWRITING

Writing is tiring. When you have exhausted yourself on a draft, put the whole project aside, and relax for a day, a week, or a month.



Let the details fade and the immediacy subside. Think about other things until the studies and the experiments and the paper sink into that subconscious womb where they can gestate peacefully and can begin to assume a balanced form.

#### 1.1. Details of Style

While your unfinished manuscript gestates, choose your target journal. The general format for papers is standard throughout science, but the specific skeletons differ from field to field. Even within a field, each scientific journal can have its own organizational style. Select a target journal before you finish writing your paper. This way your final manuscript will have the appropriate organization and style.

All journals periodically republish their Style Rules. These have headings such as  
Instructions for Contributors  
Requirements for Manuscripts



Author Guidelines

Information for Authors

Notice to Contributors

To help biomedical authors, the International Committee of Medical Journal Editors (ICMJE) has compiled a set of widely-accepted standards for articles. These rules are used by more than 600 journals. The ICMJE's Uniform Requirements for Manuscripts Submitted to Biomedical Journals was published in 1997 in the *Annals of Internal Medicine*, **126**: 36–47. (More recent revisions of these standards can be found online at [www.icmje.org](http://www.icmje.org).)

Put a copy of the manuscript guidelines for your target journal on your desk, alongside a general style manual (see Appendix E for suggestions) and a dictionary.

## 1.2. Rewrite

After a rest and when you feel fresh, bring out your manuscript again. Before you face the content, adjust the form to fit the style requirements of your target journal.

- Rewrite the Abstract in the form used by your journal.
- Choose keywords to append to the title, if these are required.
- Change text citations to the appropriate style.
- Translate your References into the correct bibliographic format.

Then attack the substance of the paper anew. Go through the steps outlined in the chapters above, improve the figures, check the tables, make the order of the sentences more logical, and shorten the Abstract.

When you tire of the details, reexamine the structure of the paper. Begin by reading through the headings. Could you use more headings? Are long subsections broken into enough separate parts? Are the headings symmetrical: if you have a “Measurements Before Treatment” do you also have a “Measurements After Treatment”?



Each time you return to your manuscript, be satisfied with making some improvements and then set the draft aside.

### 1.3. A Friendly Critique

When you feel that you have done all that you can, it's time for an independent perspective. Find a friendly reader, and ask for a critique. Besides making general comments, also ask your reader to mark the places where he or she stumbles or stops to reread a sentence—these are sure to be problem areas. Afterward, listen to the report without interrupting to explain or to justify. Then go fix the manuscript.

### 1.4. Read the Paper Backwards

To learn to draw pictures of the real world, students are often advised to look at a scene upside down, through a grid, or otherwise broken into very small pieces.

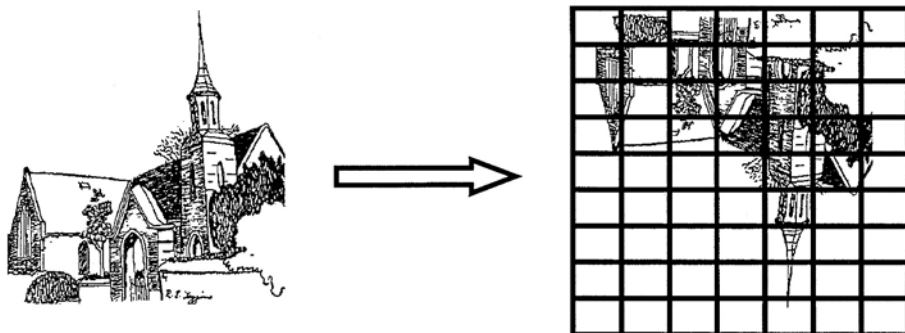

The goal is to make the scene into a set of abstractions.

Normally, we don't attend consciously to many of the actual details of edge, contour, and shadow. Instead, we create a vision of objects and scenes as wholes. Our brains give a scene meaning by adding depth, revising edges, and tempering variations in lighting. Much of what we think we see is a creation of our brains.

When bits of the scene are taken totally out of context, however, they revert to abstract patterns of light, dark, line, and shape. In an abstraction, we can see the details separately and starkly. They register simply as themselves, and they become easier to copy.

By this time in your writing, your manuscript has become too familiar. Your brain has built a picture of your paper that may not yet be clearly written on the page. You jump past the details of the wording and instead you read sentences and paragraphs as wholes. You already know what you mean to say, so you are desensitized to awkward and unclear phrases.

It is time to make your manuscript unfamiliar. Turn it upside down by reading it backwards, sentence by sentence.

Take each sentence on its own, out of context. Be certain that it is clear and simple. If it is too long, cut out words or break it into two sentences. Craft it to be clean and to the point.

### YOUR MANUSCRIPT

#### A. INTRODUCTION

Scientific articles are the repositories of scientific observations, and they give the recipes by which those observations can be repeated. Scientific papers have a stereotyped format: Abstract, Introduction, Materials and Methods, Results, Discussion, Conclusions, References.

#### B. MATERIALS AND METHODS

Within this stereotyped format, the language of a scientific paper should be clean, clear, and unemotional. Much of the color of our everyday language derives from ill-defined, emotionally charged, ear-tickling images.

#### C. RESULTS

Beyond a stereotyped format and clarity of language, a scientific paper also needs clarity of direction.

#### D. DISCUSSION

A scientific paper must be useful to others. Having your paper reviewed by experts ensures that it can be understood and used by a broad scientific community.

#### E. CONCLUSION

The scientific community will have the chance to use it.

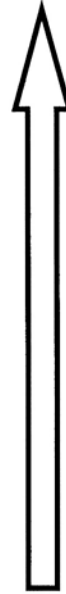

### Read from the End to the Beginning

You will find that the order of your arguments is strange when followed backward. The unfamiliarity will let you check your logic with a fresh eye.

Work your way through every section. Make your paper read crisply from upside down, as well as from right-side up.

## 1.5. Spelling

One of the great mysteries of writing is how, after 10 rereadings, my manuscripts still contain misspelled words. Misspellings and typographic errors make a paper look like it was carelessly written and hastily sent out. Use a computer spell-checker before you put your manuscript in the mail or email it to a journal.

## 2. FINAL MANUSCRIPT PREPARATION

When you send your finished manuscript to the journal, it should be in a form that can be directly used by the editors. The following guidelines apply to both physical and electronic manuscripts:

*Font:* Use a clean, standard font. Appropriate, easy-to-read fonts include: Arial, Microsoft Sans Serif, Tahoma, Times Roman, and Verdana.

*Line Spacing:* Double space all the text, including the References, Footnotes, and Figure Legends. Double space manuscripts submitted as electronic files, also.

*Margins:* Leave large margins. For a standard 8.5" × 11" page, the top, bottom, and both side margins should be 1–1.25" wide.

*Page Numbers:* Number every page in your manuscript packet. Add an identifier, such as "Katz, page 18."

*The Manuscript Packet Itself:*

Page 1—The first page of your manuscript packet is the identification page. It should include the article title, the full names of the authors and their institutional affiliations, and the name and the contact information of the author taking responsibility for interacting with the editors. The identification page should look like this:

**Intensifier For Bodian Staining of Tissue Sections  
and Cell Cultures**

Michael J. Katz and Lynne F. Watson  
Department of Anatomy  
Case Western Reserve University  
Cleveland OH USA

correspondence:

Dr. Michael Katz  
Dept. of Anatomy  
Case Western Reserve University  
10900 Euclid Ave.  
Cleveland OH 44106-4977  
USA  
mjk8@case.edu  
tel. 216-368-2390

Katz, page 1

Page 2—The second page has a summary of the manuscript packet and any necessary disclosures, qualifications, and disclaimers.

- a) The summary includes the number of pages in the manuscript packet, the number of words in the main text, the number of figures (itemized as tables, graphs, drawings, and photographs), and the number of additional items (footnotes, appendixes, etc.) if there are any. For example:

Manuscript:  
 pages = 12  
 words = 1451  
 tables = 0  
 drawings = 1 (black-and-white)  
 photographs = 3 (half-tone)

- b) The disclosures, qualifications, and disclaimers begin with the sources of funding for the research project. If the journal requires a Conflict of Interest statement, it belongs in this section.

“Funding: A grant to MJ Katz from the Whitehall Foundation.”

“Conflicts of Interest: The authors have no conflicts of interest with regard to this research or its funding.”

Page 3—The third page is the Abstract (with KEY WORDS, if this is the journal’s style).

Page 4—The manuscript proper begins on page 4 of the manuscript packet.

Final pages—At the end of the manuscript text and after the References section put any Appendixes. Next, put a page for any Footnotes. Following these, put each Table and Figure on a separate page. End the packet with a page for all the Figure Legends. Remember to number every sheet included in the manuscript packet.

*The Introductory Letter:* Send your manuscript packet with a short, formal cover letter. In the letter, give the type of article that you are submitting (original research paper, brief report, review article, commentary, or letter), the full title of the article, the authors’ names, a statement that they have each read the article and take responsibility for its content, and a statement detailing any possible conflicts of interest. For example:

Dr. Janet Jones, Editor  
*Stain Technology*

May 24, 2004

Dear Dr. Jones,

Please consider the accompanying original research manuscript “Intensifier For Bodian Staining of Tissue Sections and Cell Cultures” by Michael J. Katz and

Lynne F. Watson for publication in *Stain Technology*. In this paper, we describe a chemical intensification procedure for a classic silver-based nerve stain. Both authors have read and approved the manuscript and take full responsibility for its content. The authors have no conflicts of interest in regard to this research or its funding.

Sincerely,  
Michael J. Katz

Dept. of Anatomy  
Case Western Reserve University  
10900 Euclid Ave.  
Cleveland OH 44106-4977  
USA  
mjk8@case.edu  
tel. 216-368-2390

With your introductory letter, include copies of any permissions that you obtained to reproduce material from other sources.

When you are sending a paper version (as opposed to electronic files) of your manuscript, be sure to include as many copies as are required by the journal.

### 3. RESPONDING TO EDITORS AND REFEREES

You send a polished version of your manuscript to a journal. After a few months, you will receive a packet with an editor's letter and anonymous reviews by 2–4 referees.

Each review will be a critique that includes an overall evaluation and a list of items that need improving. Based on the reviews, the editor's letter will put your paper into one of three categories.

- The manuscript is accepted, pending specified changes.
- The manuscript requires revision and then re-review.
- The manuscript is rejected.

Regardless of the categorization, use this as an opportunity to rework your paper.

#### 3.1. A Precritique Rewrite

Before you study the referees' comments, take time to reread the manuscript. Ask yourself: "Where do I read things over twice?" and "Where am I uncomfortable?" You will naturally feel those spots that are poorly written, weakly argued, confusingly phrased, and meagerly researched. Inevitably, you will resist facing these particular difficulties. You resist because, through your many reworkings, you have already found these places hard to fix. Steel yourself, and improve the problem areas, one by one.<sup>1</sup>

#### 3.2. The Comment-by-Comment Letter

Now read the reviews carefully. Begin the revision of your manuscript by drafting the letter that will accompany it back to the editor. Even if your paper has been rejected, you can resubmit it with a thoughtful letter.

The return letter should describe the changes you have made. In the first paragraph, summarize your initial repairs, although those changes may have originated from you and not the reviewers.

March 21, 2006

"Dear Editor,

I am enclosing a revised copy of my manuscript "Guatemalan Tarantulas Have 6–9 Dorsal Stripes." I followed the reviewers' 8 suggestions. I have also taken this opportunity to improve the writing in the Discussion and to change the order of the tables in the Results. The revised version is 3 paragraphs shorter and includes 6 new references."

<sup>1</sup> Will the rewriting never end? When I was a student and had not yet attempted any science writing, Kenneth Warren, a professor of mine, told me this harrowing story: 'I already had my MD and was doing a fellowship at the National Institutes of Health, studying liver disease. I brought the draft of my first manuscript to my boss. The next day, he handed it back to me with big question marks and X-ed out paragraphs. "Re-write this," he said. Over and over, I gave him clean new drafts and he gave me back worn, thickly-penciled pages. More than 20 drafts came and went this way. Even after we sent the paper off for review, I found penciled comments on my desk. I vowed never to treat my students or post-docs so critically. And now? Twenty re-writes is what it takes for every one of my students, post-docs, and research fellows. I've found it's inescapable.' At the time, I thought that Dr. Warren was exaggerating. I can now assure you, he was not.

The remainder of the letter should itemize the specific improvements made in response to the reviewers' comments. Take the reviews comment by comment. If the suggestion makes sense to you, make the indicated change in the manuscript.

After making a change, write a sentence in your letter repeating the referee's suggestion and describing your response. Number each change.

"Here are the details of my responses to the reviewers' suggestions:

1. Reviewer A said it was unlikely that I could infer an effect from only 16 cases. Therefore, I've added the results of a t-test, showing that the likelihood that my data are chance variants of a normal distribution are less than 5%.
2. Reviewer A also pointed out that the second paragraph in the Discussion was wordy and imprecise. I have tightened the logic, taken a clearer stand, and in the process removed more than 20 words.
3. Reviewer B said that tarantulas with 9 stripes have never been seen. Rawski (1943) reported seeing both 8- and 9-striped spiders on his war-time expedition to Guatemala. I have added this reference to my Introduction...."

### **3.3. Stay Calm**

Be polite in your letter. Most reviewers write with the best of intentions, but they rarely have the time to produce thorough, well-thought-out, error-free critiques. Some of the suggestions will not be useful. Pass over these comments. Also, ignore any emotion injected by the reviewer. All scientists have been hit with criticisms that sting. A referee once wrote of one of my manuscripts: "If this paper is published, it will set science back 50 years." The best thing to do with such a comment is to save it as an anecdote for the end of your guide to science writing.

## Appendix A

### WORDS THAT ARE OFTEN MISUSED

- **Ad hoc** *adjective*

“Ad hoc” means “for this special purpose.” An ad hoc committee is a committee specially convened for a particular purpose. Ad hoc assumptions are assumptions chosen expressly for the situation at hand. “Ad hoc” does not mean “temporary,” “casual,” or “without substantial basis.”

- **Affect/Effect** *verb/noun*

“Affect” is usually a verb, as in: “Sunlight affected her mood.”

“Effect” is usually a noun, as in: “Her cheerful mood was the effect of sunlight.”

- **Alternate/Alternative** *adjective or noun*

“Alternate” means “every other member of a series” as in: “We assigned alternate hospital admission patients to the control and the treatment groups.”

“Alternative” means “another mutually exclusive possibility” as in: “We chose an alternative drug protocol.” Don’t use the vague expression “viable alternative.” Be precise. Replace “viable” with a more informative adjective, as in: “The only available [injectable, non-toxic, legal, already prepared, water-soluble, nonmagnetic, indelible, luminescent, inexpensive, non-zero, . . . ] alternative was . . .”

- **All together/Altogether** *adverb*

“All together” means “all at once or all in one place” as in: “The four toddlers ate lunch all together [or just “together”].”

“Altogether” means “when considered as one group or when taken together” as in: “Altogether, the four toddlers ate six cookies.”

- **Arbitrary** *adjective*

“Arbitrary” means “without plan or design.” If you choose your experimental subjects by blindly pulling them from a pool of candidates, you are choosing them arbitrarily, not randomly. Truly random choices require very specific rules. (See **Random** below.)

- **Classic/Classical** *adjective*

“Classic” means “outstanding example” as in: “Albert Lehninger wrote a classic biochemistry textbook.”

“Classical” means “pertaining to Greek and Roman culture” as in: “In section one,



Lehninger uses contemporary data and classical reasoning to explain the origins of alchemy.”

- **Comprise/Compose/Constitute/Include** *verb*

“Comprise” is transitive and its subject is a container. “Comprise” means “embrace” as in: “My circle of friends comprises only a guinea pig and a dog.” [Write “comprises” not “is comprised of.”] When you use “comprise,” you are talking about all the elements of the container.

“Include” is transitive and its subject is also a container. “Include” means the more general term “contain” as in: “My circle of friends includes a guinea pig.” When you use “include,” you can talk about only some elements of the container.

“Compose” and “constitute” are transitive and their subjects are the containees, that is, the elements in the container. For example, “A guinea pig and a dog compose [or “constitute”] my circle of friends.”

- **Conjecture/Guess/Presume/Speculate/Surmise** *verb*

“Conjecture,” “speculate,” and “surmise” are similar. These terms all mean “offer a conclusion from incomplete evidence as in: “After a brief visit to the crime scene, Holmes conjectured [“speculated” “surmised”] that the killer was a neighbor.”

“Presume” means “conclude from previous knowledge or experience” as in: “From those footprints, Watson, we can presume that the killer was less than five feet tall,” said Holmes.

“Guess” means “offer a haphazard proposal” as in:

“Holmes,” said the doctor, “what would you say if I suggested an extra-terrestrial hand had been at work here?” “I would say, my dear Watson, that you have made a rather poor guess.”

- **Constantly/Continually/Continuously** *adverb*

“Constant” means “steady and unceasing” as in: “The addition of NaCl produced luminescence constantly for 2 min.”

“Continual” describes a fragmented stream of discrete events and means “repeating over and over again” as in: “The addition of KCl produced irregular bursts of luminescence continually for 1 min.”

“Continuous” describes an unbroken stream of discrete events and means “uninterrupted and without pause” as in: “The addition of LiCl produced a steady series of 0.5 sec flashes of luminescence continuously for 5 min.”

- **Correlate** *verb*

“Correlate” means “relate together.” As a verb, this term tells us very little. Avoid empty sentences about relationships using the word “correlate” as in, “The cellular effects of drug A correlated with those of drug B.” Instead, specify the particular co-relationship that applies. Write: “The cellular changes caused by drug A were identical to those caused by drug B” or “The sequence of cellular effects of drug A and drug B were the same” or “The cellular effects of drug A and drug B occurred simultaneously” or “Drug A and drug B each interacted with the same membrane molecules” or “Drug A and drug B each produced the same cellular toxicity.”

- **Data** *noun*

“Data” has become both a singular and a plural noun; no longer is there a “datum.”

- **Deduce/Induce/Infer** *verb*

“Deduce” means “particularize” or “predict a specific example” as in: “From principles in Darwin’s *The Origin of Species*, we can deduce that frogs and salamanders had common ancestors.”

“Induce” means “generalize” or “predict a larger principle” as in: “Darwin used a variety of observations including the domestic breeding of dogs to induce the principles in *The Origin of Species*.”

“Infer” is all-encompassing. It means only “conclude through logical reasoning” as in: “Somehow, Darwin inferred that the vertebrate eye evolved from simpler precursors, although those precursors were unknown in his day.”

- **Endogenous/Inherent/Innate/Intrinsic** *adjective*

“Endogenous” has an implied action. It means “produced or originating from within” as in: “Euphoria can result from endogenous opioid-like hormones produced in the brain.”

“Inherent,” “innate,” and “intrinsic” all refer to properties built into the system.

“Inherent” identifies a permanent property, as in “inherent elasticity of rubber.”

“Innate” is used for living things, as in: “innate logic of the mind” (but “inherent logic of a computer chip”).

“Intrinsic” usually describes a variable property, such as “intrinsic body temperature” or “intrinsic metabolic rate.”

- **Enhance/Increase** *verb*

“Enhance” means “heighten the contrast” as in: “We enhanced the resolution of the image” or “Well-chosen chords enhanced the clarity of the melody.”

“Increase” means “enlarge the value” as in: “We increased the brightness of the image” or “The addition of trumpets increased the volume of the melody.”

- **Incidence/Prevalence** *noun*

“Incidence” is the number of new cases, as in: “The incidence of type I diabetes in the U.S. is 30,000 cases each year.”

“Prevalence” is the total number of cases at the moment, as in: “In 2003, the prevalence of type I diabetes in the U.S. was 1.3 million cases.”

- **Lay/Lie** *verb*

“Lay” (*lay, laid, laid, laying*) is transitive. It means “place something” as in: “We laid the tubing along the ridge.”

“Lie” (*lie, lay, lain, lying*) is intransitive. It means “recline:” “The tubing lay along the ridge.”

- **Necessary/Sufficient** *adjective*

“Necessary” means “absolutely required for a certain result” as in: “Drug A is necessary—without it, patients will not recover.”

“Sufficient” means “by itself will produce a certain result” as in: “Drugs B and C are each a sufficient therapy—either drug will cure the patient.”

- **None** *pronoun*

“None” can mean “not any” or “not one.” “None” can take either a plural or a singular verb, depending on the context. In other words, you can write “None of the

electrodes were bent by the insertion procedure” and also “None of the salt solution was administered before eye movements began.”

- **Natural/Normal/Physiologic/Regular/Standard** *adjective*

“Natural” means “as occurs in nature without human intervention” as in: “Shampooing your dog washes out natural oils.”

Use “normal” with caution around numbers. Technically, “normal” refers to a very specific grouping of numbers. “Normal” is the name of the smooth bell-shaped curve fitting the equation  $y = K \exp(-x^2/2)$ , as used in: “The diameters of 344 hybrid peas have a normal distribution, with a mean of 0.83 mm and a standard deviation of 0.041 mm.” To avoid confusion, don’t describe numbers as normal in any other context.

“Physiologic” (or “physiological”) means “within the range of a healthy functioning organism” as in: “To approximate the natural condition, we use physiologic doses of insulin to treat diabetes.”

“Regular” means “at even intervals (of either time or space)” as in: “The tones were regular, occurring once every 2.5 sec” or “The spots formed a regular line along its back—there was one spot every 4.2 mm.”

“Standard” means “matching a particular pre-defined description” as in: “We used the standard solution specified by Holtfreter (1953)” or “The apparatus was bathed in oxygen at body temperature (37°C) and standard pressure (760 mm Hg).”

- **Open/Opened** *adjective/verb*

In the phrase “to be open,” “open” is an adjective. “The jar was open” reports simply that we found no cover on the jar.

In the similar-sounding phrase “to be opened,” “opened” is a verb. “The jar was opened” tells us:

- a) at one time the jar had been covered,
- b) afterward, someone took off the cover.

In other words, “We discovered that the window was open” does not tell us whether the window had ever been closed. While “We discovered that the window was opened” tells us that at an earlier time the window had been closed and that somebody then opened it.

- **Paradigm** *noun*

“Paradigm” means “model” or “example” as in: “We used the Billington paradigm when designing our questionnaire.” “Paradigm” is not the same as “archetype,” “paragon,” or “prototype.” These words mean “original or particularly noteworthy models or examples” as in: “Recently, Billington’s paradigm has replaced the previous prototype and is now considered to be the standard for designing questionnaires.”

- **Pertinent/Relevant/Salient** *adjective*

“Pertinent” means “has a *logical and precise* bearing on the matter at hand” as in: “These are the two formulas that are pertinent to our geometric calculation.”

“Relevant” is more general. It means only “has a bearing on the subject at hand” as in: “A discussion of acute angles is relevant to our geometric calculation.”

“Salient” is different. It means “striking” and “conspicuous” as in: “The reviewer’s religious terminology was the most salient part of her commentary on our geometric calculation.” Salient things need not be pertinent or relevant.

- **Random** *adjective*

Technically, “random” has two meanings.

- 1) A machine or a process is **random** if its output is as unpredictable as possible. The classic example is *coin flipping*, a process that produces an unpredictable result each time it is tried.
- 2) A sequence of numbers is **random** if its order is as heterogeneous as possible. This type of randomness is sometimes called “iid random,” which stands for *identically and independently distributed random*.

When you are randomizing items in an experiment, you want to use iid random sequences of numbers. These sequences contain the maximum number of different subsequences or subpatterns. In this way you make it unlikely that any patterns inherent in your experimental items will match the sequence that you assign them. When randomizing items in an experiment, you do *not* want to use numbers produced by a random process. If you flip a coin, you are not guaranteed to produce an iid random number. Instead, you may get a very orderly, homogeneous sequence, such as HHHTTT.

In your writings, use the word “random” carefully. In most cases, it is better to use “heterogeneous,” “irregular,” “disorganized,” or “with no discernible pattern.” In cases where you have assigned items to an order without using a prechosen iid random sequence, you should say that the order was assigned “arbitrarily” not “randomly.”

- **Significant** *adjective*

In a scientific paper, reserve this adjective for statistical descriptions, and then use it only when the appropriate statistical tests have been applied. Scientifically, “significant” should always followed by its mathematical limits, which are written as: “( $P < 0.01$ ,  $t$ -test).” When using “significant,” the sentence you write is actually a shorthand. You write: “The difference between these two data sets was significant ( $P < .01$ ,  $t$ -test).” But you mean: “Using the  $t$ -test, we have calculated that the chances are less than 1 out of 100 that these two data sets are just chance variants drawn from the same large set of possible data points.”

- **That/Which** *pronoun*

“That” separates out items from a group. “The drugs that caused an adverse reaction had bacterial contaminants.” Here, of all the drugs under consideration, only those causing an adverse reaction are being discussed.

“Which” gives additional, parenthetical information about *all* the elements. “The drugs, which caused an adverse reaction, had bacterial contaminants.” In the latter case, *all* the drugs under consideration caused an adverse reaction.

- **Via/Using** *preposition*

“Via” means “taking the route of.” “We traveled from Maine to Florida via Route 1.” Or “We slipped the catheter in via the femoral vein.” “Via” does not mean “by means of”—when you aim for this meaning, write: “We traveled from Maine to Florida using [not “via”] a restored Model-T Ford,” or “We injected glucose through the catheter using [not “via”] a peristaltic pump.”

## Appendix B

### **SIMPLIFYING WORDY, REDUNDANT, AND AWKWARD PHRASES**

#### **Replace**

a considerable amount of  
absolutely essential  
almost unique  
an order of magnitude more than  
as to whether

completely full  
considered as  
considering the fact that

decline  
different than  
due to the fact that

each and every  
end result  
equally as  
exact same  
exhibit a tendency

final outcome  
firstly  
first of all  
foregone conclusion  
foreseeable future

have a tendency  
having gotten  
higher in comparison to

if and when  
in close proximity to

#### **With**

many, much  
essential  
rare, uncommon  
ten times  
whether

full  
considered  
although, because

decrease  
different from, unlike  
because

each  
result  
equally  
identical  
tend

outcome  
first  
first  
expected  
future

tend  
having got  
higher than

if, when  
near

in spite of the fact that	although
in the final analysis	finally
in the realm of possibility	possible
including but not limited to	including
inside of	inside
intimate	suggest, indicate
irregardless	regardless
last but not least	finally
methodology	method, methods
multiple	many
nearly unique	rare, uncommon
obviate	prevent
orientate	orient
preventative	preventive
prove conclusively	prove
referred to as	called
regarded as being	regarded as
seeing that	because
the question of whether	whether
transpire	happen
try and	try to
up in the air	undecided
very unique	unique
whether or not	whether

## Appendix C

### STANDARD SCIENTIFIC ABBREVIATIONS

#### 1. Stand-Alone Abbreviations

and others	et al.
intravenous	i.v.
species (singular)/species (plural)	sp./spp.

#### 2. Abbreviations Used Only After Numbers

(e.g., “4 atm” but “many atmospheres”)

atmosphere	atm
byte	B
calorie	cal
centigrade (Celsius)	C
centimeter	cm
counts per minute	cpm
Curie	Ci
cycles per second	cps
day	d
decibel	db, dB
gigabyte	GB
gram	g
hertz (cycles per sec)	Hz
hour	h
kilobase	kb
kilobyte	kB
kilocalorie	kcal
kilogram	kg
kilohertz	kHz

kilometer	km
liter	l
logarithm, base 10	log
logarithm, base e	ln
megabyte	MB
megahertz	MHz
meter	m
microgram	ug
microliter	ul
micrometer (micron)	um
milliampere	mA
millicurie	mCi
milligram	mg
milliliter	ml
millimeter	mm
millimole	mmol
millirad	mR
millisecond	ms, msec
minute	min
molar (moles/liter)	M
molecular weight	mol wt, MW
month	mo
nanogram	ng
nanometer	nm
number	no.
parts per million	ppm
picogram	pg
pounds per square inch	psi
rad	R
revolutions per minute	rpm
second	s, sec
specific gravity	sp. gr.
standard deviation	SD
unit	U
volts	V
volume	vol
watt	W
week	wk
weight	wt
year	y, yr



### **3. Two Rules for Using Abbreviations**

1. All abbreviations (except sp./spp.) are the same in the singular and the plural forms. The abbreviation for “atmospheres” is “atm” not “atms”
2. Use standard abbreviations without explanation. On the other hand, when introducing a new or uncommon abbreviation, put it in parentheses after its definition the first time it appears in your paper: “We used nerve growth factor (NGF) to . . .”

## Appendix D

### TYPICAL BIBLIOGRAPHIC FORMATS

#### 1. Two General Rules for the References Section

- a. All items in your References section must be cited elsewhere in the paper.
- b. In the text, some journals cite references by author and date. Here, the format is: “(Katz, 1984)” or “(Katz and Lasek, 1985b).” In these text citations, “*et al.*” substitutes for names when there are more than two authors: “(Katz *et al.*, 1982).” In the References list, however, “*et al.*” is replaced by the authors’ names: “Katz MJ, Lasek RJ, Osdoby P, Whittaker JR and Caplan AI 1982 . . .”

#### 2. Typical Bibliographic Formats

- Articles in journals  
Katz MJ 1984 Stereotyped and variable growth of redirected Mauthner axons. *Dev Biol* 104: 199–209.  
Katz MJ and Lasek RJ 1979 Substrate pathways that guide growing axons in *Xenopus* embryos. *J Comp Neurol* 183: 817–832.  
Katz MJ, Lasek RJ, Osdoby P, Whittaker JR and Caplan AI 1982 Bolton-Hunter reagent as a vital stain for developing systems. *Dev Biol* 90: 419–429.
- Articles in books  
Katz MJ and Lasek RJ 1985 How are the elemental axon patterns produced in the spinal cord? In *Perspectives of Neuroscience: From Molecule to Mind*. Tsukada Y ed, Univ Tokyo Press, Tokyo, pp. 43–60.
- Articles accepted and awaiting publication  
Katz MJ and George EB 2003 Limits of fractal biology. *Math Life Sci*, in press.
- Books  
Katz MJ 1994 *Buckeye Legends: Folk Tales and Lore from Ohio*. Univ Michigan Press, Ann Arbor MI.

- Theses  
Katz MJ 1978 Axon guidance in developing embryos. PhD Thesis. Case Western Reserve Univ, Cleveland OH.
- Abstracts  
Katz MJ 1981 Anatomy of the ascidian tunicate tadpole, *Ciona intestinalis*. (abst) Biol Bulletin 161: 348.
- Electronic media (Videotape, CD-ROM, DVD)—  
Katz MJ 1996 Axon branching. The Electronic Encyclopedia of Biology (ver. 3.5). Ground Publishing, Boston MA.
- Internet references—  
Katz MJ 2001 accessed 5/24/2003 The Lost Dialogues—Pherecydes. Eclectica [Online] <http://www.eclectica.org/v5n1/katz.html>  
Katz MJ 2001 accessed 5/24/2003 A Bountiful Hairy Spleen. The Morpo Review [Online] <http://morpo.com/viewer.php?vol=8&iss=1&disp=9>

## Appendix E

### ADDITIONAL READING

There is much good advice on scientific writing available in libraries.

Books about technical writing:

- Alley M. 1996. *The Craft of Scientific Writing*, 3rd ed. Springer, New York.
- Beall H, Trimbur J. 2001. *A Short Guide to Writing About Chemistry*, 2nd ed. Longman, New York.
- Day RA. 1998. *How to Write and Publish a Scientific Paper*, 5th ed. Oryx Press, Phoenix, AZ.
- Huck SW. 2000. *Reading Statistics and Research*, 3rd ed. Longman, New York.
- McMillan V. 1997. *Writing Papers in the Biological Sciences*, 2nd ed. Bedford, Boston.
- Pechenik J. 1997. *A Short Guide to Writing about Biology*, 3rd ed. Longmans, New York.
- Zeiger M. 2000. *Essentials of Writing Biomedical Research Papers*, 2nd ed. McGraw-Hill, New York.
- Zobel J. 2004. *Writing for Computer Science*, 2nd ed. Springer, New York.

Standard style manuals

- *The Chicago Manual of Style*, 15th ed. 2003. Univ Chicago Press, Chicago.
- Siegal AM, Connolly WG. 1999. *The New York Times Manual of Style and Usage*. Times Books, New York.

Style manuals specifically for scientific writing

- *The ACS Style Guide: A Manual for Authors and Editors*. 1997. Am Chem Soc, Washington, DC.
- *The American Medical Association Manual of Style: A Guide for Authors and Editors*, 9th ed. 1998. Williams & Wilkins, Baltimore, MD.
- *Scientific Style and Format: The CBE Manual for Authors, Editors, and Publishers*, 6th ed. 1994. Cambridge Univ Press, New York.

Guide to statistics

- Freedman D, Pisani R, Purves R. 1997. *Statistics*, 3rd ed. Norton, New York.

Guide to scientific figures

- Tufte ER. 2001. *The Visual Display of Quantitative Information*, 2nd ed. Graphics Press, Cheshire, CT.

# Index

- abstract, 115
- abstract, simple, examples, 115
- abstract, with subsections, examples, 118
- acknowledgements, 124
- acknowledgements, examples, 124
- algorithms, 55
- appendix, 66
- appendix, example, 67
- audience of your paper, 104
  
- case studies, 81
- conclusion, 2, 101
- conclusion, examples, 101
- confidence levels, 37
- correlation, 46
  
- data, distribution, 34, 38
- data, legitimate, 28, 49, 65
- diagrams, 41, 48
- discussion, 85
- discussion, full example, 100
- discussion, combinations, 91
- discussion, combinations, examples, 92
- discussion, comparisons, 87
- discussion, comparisons, examples, 88
- discussion, empirical rules, 95
- discussion, empirical rules, examples, 97
- discussion, recap paragraph, 85
- discussion, recap paragraph, examples, 85
- distributions, mathematical, 34, 38
  
- empirical rules, 95
- empirical rules, examples, 97
  
- figure legends, 29, 43
- figures, 41
- figures, creating, 48
- footnotes, 123
- footnotes, examples, 123
  
- graphs, 43
- graphs, examples, 44, 46, 48, 80
  
- histograms, 43
- histograms, examples, 44
  
- induction, mathematical, 26
- introduction, 104
- introduction, examples, 105
- introduction, full example, 112
- introduction, plan-of-attack, 105
  
- journal styles, 125
  
- key variables, 65, 70, 78
- key words, 115
  
- lab notebook, 51, 55
- letter, response to reviewers, 132
- letter, with manuscript packet, 130
  
- manuscript packet, 129
- manuscript preparation, final, 129
- materials and methods, 54
- materials and methods, examples, 57, 62, 63
- materials and methods, organization of, 62
  
- nonparametric tests, 38
- normal distribution, 34

- null hypothesis, 36
  - numbers, use of, 4
  - numbers, usefulness of, 25
  - numerical data, 78
- P* values, 37
- paragraphs, examples, 21
- patterns, 47, 49, 70
- pictures, 41, 43, 76
- recipe* → results report, 69, 95, 96
- referees, response to, 132
- references, 121
- references, original sources, 121
- references, formats, 122
- results, 68
- results, case studies, 81
- results, case studies, best cases, examples, 82
- results, case studies, representative cases, examples:, 83
- results, full example, 83
- results, general observations, 73
- results, general observations, examples, 74
- results, specific observations, 76
- results, specific observations, examples, 76, 79
- scatter plots, 45
- scatter plots, example, 46
- scientific journals, styles and formats, 125
- scientific language, quantifiable words, 4
- scientific language, well-defined words, 5
- scientific paper, clear direction of, 2
- scientific paper, format, stereotyped, 1, 53
- scientific patterns, 47, 49
- scientific writing, well-written paragraphs, examples, 21
- significance tests, 37
- significance tests, choosing, 39
- standard deviation, 32
- statistics, 30
- statistics, central 50%, 32
- statistics, descriptive (size, range, mean, mode, median), 31
- statistics, in materials and methods, examples, 61
- statistics, inferential, 33, 36
- statistics, nonparametric tests, 38
- statistics, normal distribution, 34
- statistics, null hypothesis, 36
- statistics, population, 34
- statistics, sample, 34
- statistics, significance tests, 37
- statistics, significance tests, choosing, 39
- statistics, standard deviation, 32
- statistics, *t*-tests, 37
- t*-test, 37
- tables, creating, 27
- tables, examples, 28, 30, 79
- title, 113
- title, examples, 113
- translation to English, 23
- variable, 27, 49, 65
- verb tense, past, 6
- verb tense, present, 5
- writing process, beginning a draft, 52
- writing process, last rewrites, 126
- writing process, lead sentences, 12
- writing process, lists, 7, 14, 16
- writing process, polishing, 17, 18, 127
- writing process, references, 8, 121
- writing process, rough paragraphs, 12, 17
- writing process, rough sentences, 9
- writing process, simple sentences, 15
- writing process, skeletal outline, 6