

HOMOTOPY OF OPERADS
&
GROTHENDIECK-TEICHMÜLLER GROUPS

—
PART I

by

Benoit Fresse

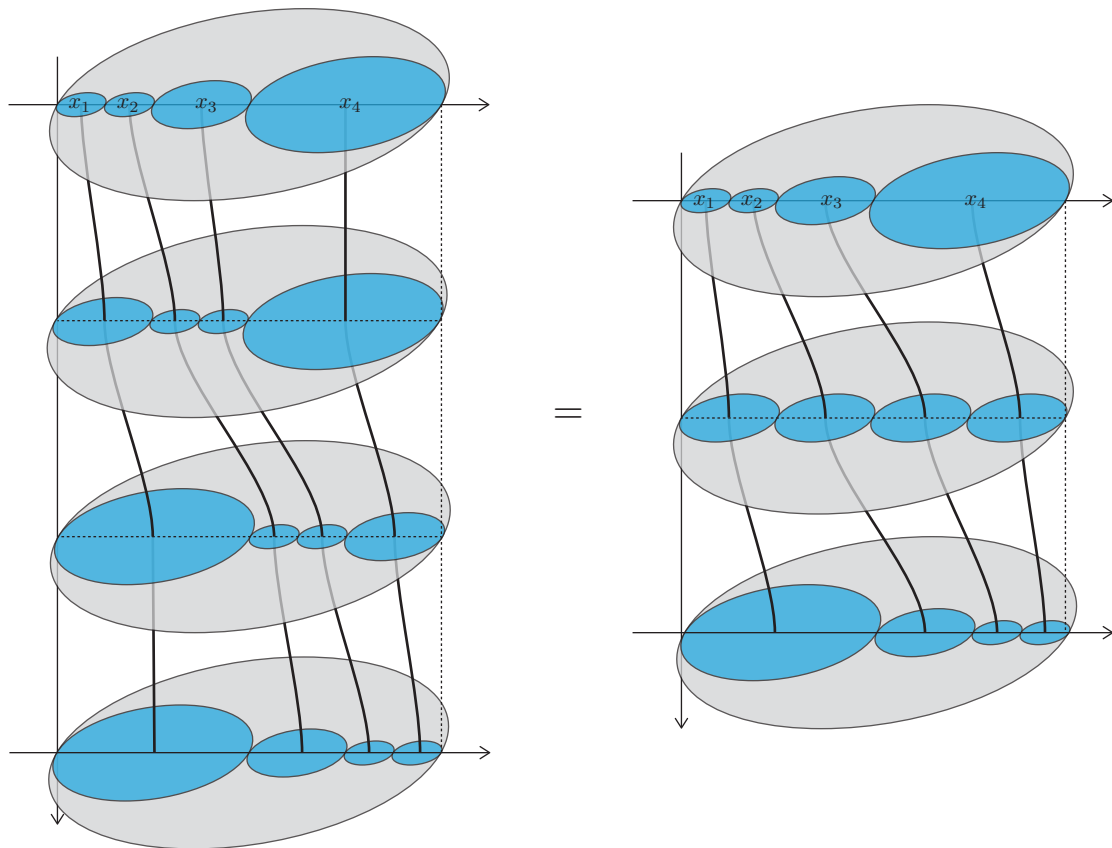

Homotopy of Operads & Grothendieck-Teichmüller Groups
Book in preparation

by:

Benoit Fresse

Laboratoire Paul Painlevé, UMR CNRS 8524

Université Lille 1 - Sciences et Technologies

Cité Scientifique - Bâtiment M2

F-59655 Villeneuve d'Ascq Cedex

France

Email: Benoit.Fresse@math.univ-lille1.fr

Part I: "From Operads to Grothendieck-Teichmüller Groups"

31 December 2012 (minor updates on January 22, February 8)

correction notes added on July 22, 2013

October 16, 2013

March 2, 2014

HOMOTOPY OF OPERADS
&
GROTHENDIECK-TEICHMÜLLER GROUPS

—
Part I: From Operads to Grothendieck-Teichmüller Groups

by
Benoit Fresse

This document is the first part of a research monograph in preparation on the homotopy of operads and Grothendieck-Teichmüller groups. The ultimate objective of this work is to prove that the Grothendieck-Teichmüller group is the group of homotopy automorphisms of a rational completion of the little 2-discs operad.

The full monograph will include two volumes. This first volume includes a comprehensive introduction to the fundamental concepts of operad theory, a survey chapter on little discs and E_n -operads, a detailed study of the connections between little 2-discs and braids, an introduction to the theory of Hopf algebras and the Malcev completion of groups, and a report on the definition of the Grothendieck-Teichmüller group from the viewpoint of the theory of algebraic operads. Most concepts are carefully reviewed in order to make this account accessible to a broad readership, which should include graduate students as well as researchers coming from various fields of mathematics related to our main topics. We conclude this part with the definition of a map from the pro-unipotent Grothendieck-Teichmüller group towards the group of homotopy automorphism classes of the rationalization of the little 2-disc operad. The proof that this map defines an isomorphism is the subject of the second volume.

This volume covers the content of a master degree course “Operads 2012”, given by the author at université Lille 1, from January until April 2012. See:

<http://math.univ-lille1.fr/~operads/2012courses.html#Lille>

This work has in part been written during stays at the École Normale Supérieure de Paris, at Northwestern University, and at the Max-Planck-Institut für Mathematik in Bonn. The author is grateful to these institutions for outstanding working conditions, and to numerous colleagues for their warm welcome which has greatly eased this writing task. I thank Christine Vespa for many accurate observations on this work. I am also grateful to the participants of the course “Operads 2012” for invaluable feedbacks on the matter of this volume.

Lille, 31 December 2012
Benoit Fresse

Contents of volume I: “From Operads to Grothendieck-Teichmüller Groups”

Foreword	v
General introduction	vii
Mathematical objectives	xi
Contents	xix
Foundations and conventions	xxix
Part 0. The general theory of operads	3
Chapter 1. The basic concepts of the theory of operads	5
§1.1. The notion of an operad and of an algebra over an operad	6
§1.2. Categorical constructions on operads	22
§1.3. Categorical constructions on algebras over operads	34
§1.4. Appendix: filtered colimits and reflexive coequalizers	41
Chapter 2. Operads in symmetric monoidal categories	43
§2.0. Commutative (co)algebras in symmetric monoidal categories	43
§2.1. The definition of operads in symmetric monoidal categories	48
§2.2. The notion of a Hopf operad	52
§2.3. Appendix: functors between symmetric monoidal categories	61
Chapter 3. The definition of operadic composition structures revisited	65
§3.1. The partial composition product definition of an operad	66
§3.2. The definition of unitary operads	74
§3.3. Categorical constructions for unitary operads	87
§3.4. The definition of connected unitary operads	91
§3.5. Operads and symmetric collections	98
Part 1. Braids and E_2-operads	105
Chapter 4. The little discs model of E_n -operads	107
§4.1. The definition of the little discs operads	108
§4.2. The homology (and cohomology) of the little discs operads	118
§4.3. Outlook: variations on the little discs operads	127
§4.4. Appendix: the symmetric monoidal category of graded modules	133
Chapter 5. Braids and the recognition of E_2 -operads	135
§5.0. Braid groups	136
§5.1. Braided operads and E_2 -operads	143
§5.2. The classifying spaces of the colored braid operad	154
§5.3. Fundamental groupoids and operads	163
§5.4. Outlook: the recognition of E_n -operads for $n > 2$	169
Chapter 6. The magma and parenthesized braid operad	171
§6.1. Magmas and the parenthesized permutation operad	172
§6.2. The parenthesized braid operad	181
Part 2. Completions and Grothendieck-Teichmüller groups	195
Chapter 7. Hopf algebras	197
§7.1. The notion of a Hopf algebra	198
§7.2. Lie algebras and Hopf algebras	206
§7.3. Lie algebras and Hopf algebras in complete filtered modules	225
Chapter 8. The Malcev completion for groups	243
§8.1. The adjunction between groups and complete Hopf algebras	244

§8.2. The category of Malcev complete groups	248
§8.3. The Malcev completion of free groups	252
§8.4. Malcev completions in the rational coefficient case	255
Chapter 9. The Malcev completion for groupoids and operads	257
§9.1. The notion of a Hopf groupoid	258
§9.2. The Malcev completion for groupoids	261
§9.3. Symmetric monoidal structures and operads	265
Chapter 10. The definition of the Grothendieck-Teichmüller group	269
§10.1. The prounipotent Grothendieck-Teichmüller group	269
§10.2. The operad of chord diagrams and associators	274
§10.3. The graded Grothendieck-Teichmüller group	286
§10.4. The Knizhnik-Zamolodchikov associator	292
Recapitulation and outlook	297
The homotopy interpretation of the Grothendieck-Teichmüller group	299
The Grothendieck program	303
Bibliography	309

Contents of volume II: “Homotopy of Operads and Deformation Complexes”

Part 0. Homotopical algebra methods
Chapter 1. Model categories and homotopy
Chapter 2. Cofibrantly generated model categories
Part 1. The rational homotopy of operads
Chapter 3. Model structures for operads in simplicial sets
Chapter 4. Models for the rational homotopy of spaces
Chapter 5. Models for the rational homotopy of operads
Chapter 6. Models for the rational homotopy of unitary operads
Chapter 7. The rational model of E_n -operads
Part 2. operadic deformation complexes
Chapter 8. Cosimplicial deformation complexes
Chapter 9. Differential graded reductions
Chapter 10. Koszul reductions and applications to E_2 -operads
Part 3. Spectral sequences for operadic mapping spaces
Chapter 11. General obstruction theory for operads
Chapter 12. The Drinfeld-Kohno tower and the associated spectral sequence
Afterword
Appendices
Appendix A. The construction of free operads
Appendix B. Composite free operads, monads and comonads
Appendix C. The construction of cofree cooperads
Appendix D. The construction of cooperad pullbacks
Bibliography

Foreword

General Introduction

The first purpose of this work is to give an overall reference, starting from scratch, on applications of algebraic topology methods to the study of operads in topological spaces. Most definitions, notably fundamental concepts of operad and homotopy theory, are carefully reviewed in order to make our account accessible to a broad readership, including graduate students, and researchers coming from the various fields of mathematics related to our subject.

Then our ultimate objective is to give a homotopical interpretation of a deep relationship between operads and Grothendieck-Teichmüller groups. This connection, which has emerged from research on the deformation quantization process in mathematical physics, gives a new approach to understanding internal symmetries of structures occurring in various constructions of algebra and topology.

We review the formal definition of an operad in the first part of this volume. Simply recall for the moment that an operad is a structure, formed by collections of abstract operations, which is used to define a category of algebras. In our study, we mainly consider the example of E_n -operads, $n = 1, 2, \dots, \infty$, used to model a hierarchy of homotopy commutative structures, from fully homotopy associative but not commutative ($n = 1$), up to fully homotopy associative and commutative ($n = \infty$). For the reader, we should mention that the notion of an E_1 -operad is synonymous to that of an A_∞ -operad, used in the literature when one only deals with purely homotopy associative structures.

The notion of an E_n -operad formally refers to a class of operads, rather than to a singled out object. This class consists, in the initial definition, of topological operads which are homotopically equivalent to a reference model, the Boardman-Vogt operad of little n -discs D_n . The operad of little n -cubes, which is a simple variant of the little n -discs operad, is also used in the literature to provide an equivalent definition of the class of E_n -operads. We provide detailed recollections on these notions in the second part of this volume. Nevertheless, as we explain soon, our main purpose is not to study E_n -operads themselves, but homotopy automorphisms groups attached to these structures.

Before explaining this goal, we survey some motivating applications of E_n -operads, which are not our main subject matter (we only give short introductions to these topics), but illustrate our approach of the subject.

The operads of little n -discs D_n were initially introduced to collect operations acting on iterated loop spaces. The first main application, which has motivated the definition of these operads, was the Boardman-Vogt and May recognition theorems asserting, in the most basic outcome, that any connected space equipped with an action of D_n is homotopy equivalent to an n -fold loop space $\Omega^n X$ (see [25, 26] and [134]).

Recall that the set of connected components of an n -fold loop space $\Omega^n X$ is identified with the n th homotopy group $\pi_n(X)$ of the space X , a group which is abelian as soon as $n > 1$. The action of D_n on $\Omega^n X$ includes a product operation $\mu : \Omega^n X \times \Omega^n X \rightarrow \Omega^n X$ which, at the level of connected components, gives the composition operation of the group $\pi_n(X)$ for any $n > 0$. The operad D_n carries the homotopies making this product associative (and commutative for $n > 1$), and includes further operations, representing fine homotopy constraints, which we need to form a faithful picture of the structure of the n -fold loop space $\Omega^n X$.

This outline gives the initial topological interpretation of E_n -operads. But this topological picture has also served as a guiding idea for a study of E_n -operads in other domains. Indeed, new applications of E_n -operads, which have initiated a complete renewal of the subject, have been discovered in the fields of algebra and mathematical physics, mostly after the proof of the Deligne conjecture asserting that the Hochschild cochain complex $C^*(A, A)$ of an associative algebra A inherits an action of an E_2 -operad. In this context, we deal with a chain version of the previously considered topological little 2-discs operad D_2 .

The cohomology of the Hochschild cochain complex $C^*(A, A)$ is identified in degree 0 with the center $Z(A)$ of the associative algebra A . In a sense, the Hochschild cochain complex represents a derived version of this ordinary center $Z(A)$. From this point of view, the construction of an E_2 -structure on $C^*(A, A)$ determines, as in the study of iterated loop spaces, a fine level of homotopical commutativity of the derived center, beyond an apparent commutativity occurring at the cohomology level. The first proofs of the Deligne conjecture have been given by Kontsevich-Soibelman [106] and McClure-Smith [135]. The interpretation in terms of derived centers has been emphasized by Kontsevich [104] in order to formulate a natural extension of the conjecture for algebras over E_n -operads, where we now consider any $n \geq 1$.

The verification of the Deligne conjecture has yielded a second generation of proofs, promoted by Tamarkin [169] and Kontsevich [104], of the Kontsevich formality theorem giving the existence of deformation quantizations. These new approaches also involve the application of Drinfeld's associators, which are used to transport the E_2 -structure yielded by the Deligne conjecture on the Hochschild cochain complex to the cohomology. In the final outcome, one obtains that each associator gives rise to a deformation quantization functor. This result has hinted the existence of a deep connection between the deformation quantization problem and the program, initiated in Grothendieck's famous "esquisse" [82], which aims to understand Galois groups through geometric actions on curves. The Grothendieck-Teichmüller groups are devices, introduced in this program, encoding the information which can be captured through the actions considered by Grothendieck. The correspondence between associators and deformation quantizations imply that a rational pro-unipotent version of the Grothendieck-Teichmüller group $GT^1(\mathbb{Q})$ acts on the moduli space of deformation quantizations. The initial motivation of our work was the desire to understand this connection from a homotopical viewpoint, in terms of homotopical structures associated to E_2 -operads. The homotopy automorphisms of operads come into play at this point.

Recall again that an operad is a structure encoding a category of algebras. The homotopy automorphisms of an operad P are transformations, defined at the operad

level, encoding natural homotopy equivalences on the category of algebras associated to \mathcal{P} . In this interpretation, the group of homotopy automorphism classes of E_2 -operads, which we actually aim to determine, represents the internal symmetries of the first level of homotopy commutative structures which E_2 -operads encode. In the rational setting, we establish that this group is isomorphic to the pro-unipotent Grothendieck-Teichmüller group $GT^1(\mathbb{Q})$. This result is new and represents the main outcome of our work. In a more general context, we formulate a conjecture relating the group of homotopy automorphism classes of E_2 -operads to a Lie algebra, defined over \mathbb{Z} , underlying a graded version of the Grothendieck-Teichmüller group.

Let us focus on the rational case. In this context, we naturally have to consider a rational version of E_2 -operads. Thus, to reach our result, we have beforehand to set up a new rational homotopy theory for topological operads and to give a sense to the rationalization of topological operads. We actually define an analogue of the Sullivan model of the rational homotopy of spaces [166] for operads. We simply deal with cosimplicial commutative algebras (instead of Sullivan's differential graded algebras) in order to work out general difficulties occurring with the model of multiplicative structures in Sullivan's theory. We also consider cooperads, the dual structures of operads, when we form our model. We precisely show that the rational homotopy of an operad in topological spaces is determined by an associated cooperad in cosimplicial commutative algebras (a cosimplicial Hopf cooperad). We have a small model of the cooperad associated to little 2-discs given by the cochain complex of certain Lie algebras, the Drinfeld-Kohno Lie algebras, which were initially introduced for the study of configuration spaces and pure braid groups from an infinitesimal viewpoint.

The other main topics considered in our study include the application of Koszul duality techniques, operadic deformation complexes and spectral sequences for the computation of mapping spaces attached to operads. We aim to give a detailed and comprehensive introduction to the applications of these methods for the study of operads from the point of view of homotopy theory.

Mathematical Goals

The ultimate goal of this work, as we explain in the general introduction, is to prove that the Grothendieck-Teichmüller group represents, at least in the rational setting, the group of homotopy automorphism classes of E_2 -operads. This objective can be taken as a motivation to read this book or as a guiding example of application of our methods.

The definition of an operad is recalled with full details in the first part of this volume. In this introductory section, we only aim to give an idea of our main results. Let us simply recall that an operad \mathcal{P} basically consists of a collection $\mathcal{P}(r)$ ($r \in \mathbb{N}$), where each object $\mathcal{P}(r)$ parameterizes operations with r inputs $p = p(x_1, \dots, x_r)$, together with a multiplicative structure, which models the composition of such operations. We can define operads in any category equipped with a symmetric monoidal structure \mathcal{M} . We then assume $\mathcal{P}(r) \in \mathcal{M}$, and we use the tensor product operation, given with this category \mathcal{M} , to define the composition structure attached to our operad. The operads in a base symmetric monoidal category form a category, which we denote by $\mathcal{M}\mathcal{O}p$, or more simply, by $\mathcal{O}p = \mathcal{M}\mathcal{O}p$, when this ambient category \mathcal{M} is fixed by the context. An operad morphism $f : \mathcal{P} \rightarrow \mathcal{Q}$ naturally consists of a collection of morphisms in the base category $f(r) : \mathcal{P}(r) \rightarrow \mathcal{Q}(r)$ ($r \in \mathbb{N}$) preserving the structures attached to operads.

For technical reasons, we have to consider operads \mathcal{P}_+ equipped with a distinguished element $* \in \mathcal{P}_+(0)$ (whenever the notion of an element makes sense), which represents an operation with zero input (a unitary operation in our terminology). In the set-theoretic context, we moreover assume that $\mathcal{P}_+(0)$ is a one-point set reduced to this element. In the module context, we assume that $\mathcal{P}_+(0)$ is a one dimensional module over the ground ring. In a general setting, we assume that $\mathcal{P}_+(0)$ is the unit object given with the tensor structure of our base category. We then say that \mathcal{P}_+ forms a unitary operad. We use the notation $\mathcal{O}p_*$ to refer to the category of unitary operads. The lower-script $*$ indicates the fixed arity zero component assigned to this category of operads. We usually consider together both a non-unitary operad \mathcal{P} , which has no term in arity 0, and an associated non-unitary operad \mathcal{P}_+ , where the arity zero term, spanned by the distinguished operation $* \in \mathcal{P}_+(0)$, is added. We therefore follow the convention to use a lower-script $+$, marking the addition of this term, for the notation of the unitary operad \mathcal{P}_+ . We often perform constructions on the non-unitary operad \mathcal{P} first, and on the unitary operad \mathcal{P}_+ afterwards, by assuming that the additional distinguished element (or unit term) of \mathcal{P}_+ is preserved by the operations involved in our construction. We use the expression of unitary extension to refer to this process.

In topology, an E_2 -operad usually refers to an operad in the category of spaces which is equivalent to Boardman-Vogt' operad of little 2-discs D_2 in the homotopy

category of operads. The spaces $D_2(r)$ underlying this operad have a trivial homotopy in dimension $* \neq 1$, and for $* = 1$, we have $\pi_1 D_2(r) = P_r$, where P_r denotes the pure braid group on r strands. Thus, the space $D_2(r)$ is an Eilenberg-MacLane space $K(P_r, 1)$ associated to the pure braid group P_r . For our purpose, we consider a rational pro-nilpotent completion of the little 2-discs operad \hat{D}_2 , for which we have $\pi_1 \hat{D}_2(r) = \hat{P}_r$, where \hat{P}_r denotes to the Malcev completion of the group P_r . The precise construction of such an operad \hat{D}_2 is given in a general context in the second volume of this work, where we define an operadic version of the Sullivan rationalization functor on topological spaces. We also have a simple model of this operad \hat{D}_2 which is defined by elaborating on the Eilenberg-MacLane space interpretation of the little 2-discs spaces. We give a brief outline of this approach soon.

Homotopy automorphisms can be defined in the general setting of model categories, which provide a suitable axiomatic framework for the application of homotopy theory concepts to operads. In order to introduce our subject, we first explain a basic interpretation of the general definition of a homotopy automorphism in the context of topological operads.

We have a natural homotopy relation \simeq for morphisms of operads in topological spaces. We proceed as follows to define this concept. To a topological operad Q , we associate the collection of path spaces $Q^{\Delta^1}(r) = \mathbf{Map}_{\mathcal{Top}}([0, 1], Q(r))$, which inherits an operad structure from Q and defines a path-object associated to Q in the category of topological operads. Then we explicitly define a homotopy between operad morphisms $f, g : P \rightarrow Q$ as an operad morphism $h : P \rightarrow Q^{\Delta^1}$ satisfying $d_0 h = f$, $d_1 h = g$, where $d_0, d_1 : Q^{\Delta^1} \rightarrow Q$ are the natural structure morphisms (evaluation at the origin and at the end point) associated with our path-object Q^{Δ^1} . This homotopy h is intuitively equivalent to a continuous family of operad morphisms $h_t : P \rightarrow Q$ going from $h_0 = f$ to $h_1 = g$.

In a first approximation, we take the sets of homotopy classes of operad morphisms as the morphism sets of a homotopy category $\mathbf{Ho}(\mathcal{TopOp})$ associated with the category of topological operads \mathcal{TopOp} . In principle, we have to deal with a suitable notion of cofibrant object in the category of operads, and to replace any operad by a cofibrant resolution, in order to use this definition of morphism set. The homotopy category, more properly defined after this replacement of each object by a cofibrant resolution, is identified with a localization with respect to a class of weak-equivalences in the category of operads. But we will explain this issue later on. We focus on the basic definition of the morphism sets of the homotopy category for the moment.

The groups of homotopy automorphism classes, which we aim to determine, are the groups of automorphisms in the homotopy category $\mathbf{Ho}(\mathcal{TopOp})$. The automorphism group $\mathbf{Aut}_{\mathbf{Ho}(\mathcal{TopOp})}(P)$ associated to a given operad $P \in \mathcal{TopOp}$ accordingly consists of homotopy classes of morphisms $f : P \rightarrow P$, which have a homotopy inverse $g : P \rightarrow P$ satisfying $fg \simeq id$ and $gf \simeq id$, where we consider, at each level, the operadic homotopy relation.

Note that a topological operad P gives rise to an operad object in the homotopy category of topological spaces $\mathbf{Ho}(\mathcal{Top})$, and we could also study the automorphism group $\mathbf{Aut}_{\mathbf{Ho}(\mathcal{Top})}(P)$ formed in this category of homotopical operads. But these naive automorphism groups differ from our groups of homotopy automorphisms

and do not give the appropriate structure for the homotopy version of usual constructions of group theory (like homotopy fixed points). Indeed, an automorphism of the operad P in the homotopy category of spaces $\mathbf{Ho}(\mathcal{T}op)$ is just a collection of homotopy classes of maps $f(r) \in [P(r), P(r)]$, invertible in the homotopy category of spaces, and preserving the operadic structures up to homotopy, unlike our homotopy automorphisms which preserve the operadic structures strictly. Moreover, actual operad morphisms $f, g : P \rightarrow Q$ define the same morphism of operads in the homotopy category of spaces $\mathbf{Ho}(\mathcal{T}op)$ as soon as we have a homotopy of maps (regardless of operad structures) between $f(r)$ and $g(r)$, for each $r \in \mathbb{N}$. Thus, operad morphisms which are homotopic in the strong operadic sense determine the same morphism of operads in the homotopy category of spaces $\mathbf{Ho}(\mathcal{T}op)$, but the converse implication does not hold. By associating the collection of homotopy classes of maps $f(r) : P(r) \rightarrow P(r)$ to a homotopy automorphism $f \in \mathbf{Aut}_{\mathbf{Ho}(\mathcal{T}op \circ P)}(P)$, we obtain a mapping $\mathbf{Aut}_{\mathbf{Ho}(\mathcal{T}op \circ P)}(P) \rightarrow \mathbf{Aut}_{\mathbf{Ho}(\mathcal{T}op)} \circ P(P)$, from the group of homotopy classes of homotopy automorphisms towards the group of automorphisms of the operad in the homotopy category of spaces, but this mapping is neither an injection nor a surjection in general.

To apply methods of algebraic topology, we associate to any operad P a whole simplicial set of homotopy automorphisms $\mathbf{hAut}_{\mathcal{T}op \circ P}(P)$ rather than a single group of homotopy automorphism classes. This group $\mathbf{Aut}_{\mathbf{Ho}(\mathcal{T}op \circ P)}(P)$, which we primarily aim to determine, is identified with the set of connected components of this space $\pi_0(\mathbf{hAut}_{\mathcal{T}op \circ P}(P))$. In the second volume of this work, we explain the definition of these homotopy automorphism spaces in the general context of cofibrantly generated model categories. For the moment, we simply give a short outline of the definition for topological operads.

First, we extend the definition of our path object, and we consider, for each $n \in \mathbb{N}$, an operad P^{Δ^n} defined by the collection of function spaces $P^{\Delta^n}(r) = \mathbf{Map}_{\mathcal{T}op}(\Delta^n, P(r))$ on the n -simplex Δ^n . This operad sequence P^{Δ^n} inherits a simplicial structure from the topological simplices Δ^n . In particular, since we obviously have $P = P^{\Delta^0}$, we have a morphism $v^* : P^{\Delta^n} \rightarrow P$ associated to each vertex v of the n -simplex Δ^n . The simplicial set $\mathbf{hAut}_{\mathcal{T}op \circ P}(P)$ is given in dimension n by the morphisms of topological operads $f : P \rightarrow P^{\Delta^n}$ so that the composites $v^* f$ form homotopy equivalences of the operad $P = P^{\Delta^0}$, for all vertices $v \in \Delta^n$. From this definition, we immediately see that the 0-simplices of the simplicial set $\mathbf{hAut}_{\mathcal{T}op \circ P}(P)$ are the homotopy equivalences of the operad P , the 1-simplices are the operadic homotopies $h : P \rightarrow P^{\Delta^1}$ between homotopy equivalences, and therefore, we have a formal identity $\mathbf{Aut}_{\mathbf{Ho}(\mathcal{T}op \circ P)}(P) = \pi_0 \mathbf{hAut}_{\mathcal{T}op \circ P}(P)$, between our group of homotopy automorphism classes $\mathbf{Aut}_{\mathbf{Ho}(\mathcal{T}op \circ P)}(P)$ and the set of connected components of $\mathbf{hAut}_{\mathcal{T}op \circ P}(P)$.

In what follows, we adopt a common usage of homotopy theory to call space any simplicial set regarded as a combinatorial model of a topological space. We accordingly say homotopy automorphism space for the simplicial set $\mathbf{hAut}_{\mathcal{T}op \circ P}(P)$ which we associate to an operad P .

Besides homotopy equivalences, we consider a class of morphisms, called weak-equivalences, which are included in the definition of a model structure on the category of operads. We adopt the standard notation of the theory of model categories $\xrightarrow{\sim}$ to refer to this class of distinguished morphisms. The notion of a model category also includes the definition of a class of cofibrant objects, generalizing the cell

complexes of topology, and which are well suited for the homotopy constructions we aim to address.

To be more specific, recall that a map of topological spaces $f : X \rightarrow Y$ is a weak-equivalence when this map induces a bijection on connected components $f_* : \pi_0(X) \xrightarrow{\cong} \pi_0(Y)$ and an isomorphism on homotopy groups $f_* : \pi_*(X, x) \xrightarrow{\cong} \pi_*(Y, f(x))$, for all $* > 0$, and any choice of base point $x \in X$. We define a weak-equivalence of operads as an operad morphism $f : P \rightarrow Q$ of which underlying maps $f(r) : P(r) \rightarrow Q(r)$ are weak-equivalences of topological spaces.

In the context of topological spaces, a classical result asserts that any weak-equivalence between cell complexes is homotopically invertible as a map of topological spaces. In the context of operads, we similarly obtain that any weak-equivalence between cofibrant operads $f : P \xrightarrow{\sim} Q$ is homotopically invertible as an operad morphism: we have an operad morphism in the converse direction $g : Q \rightarrow P$ as our weak-equivalence $f : P \xrightarrow{\sim} Q$ such that $fg \simeq id$ and $gf \simeq id$, where we now consider the operadic homotopy relation (as in the definition of a homotopy automorphism for operads).

The proof of the model category axioms for operads includes the construction of a cofibrant replacement functor, which assigns a cofibrant operad Q equipped with a weak-equivalence $Q \xrightarrow{\sim} P$ to any given operad P . The definition of the homotopy category of topological operads in terms of homotopy class sets of morphisms is actually the right one when we replace each operad P by such a cofibrant model $Q \xrightarrow{\sim} P$. In particular, when we form the group of homotopy automorphism classes of an operad $\mathbf{Aut}_{\mathbf{Ho}(\mathcal{T}_{op} \circ \mathcal{P})}(P)$, we have to assume that P is cofibrant as an operad, otherwise we tacitely assume that we apply our construction to a cofibrant replacement of P . The general theory of model categories ensures that the obtained group $\mathbf{Aut}_{\mathbf{Ho}(\mathcal{T}_{op} \circ \mathcal{P})}(P)$ does not depend, up to isomorphism, on the choice of this cofibrant replacement. We have similar results and we apply similar conventions for the homotopy automorphism spaces $\mathbf{hAut}_{\mathcal{T}_{op} \circ \mathcal{P}}(P)$.

We go back to the little 2-discs operad. We aim to determine the homotopy groups of the homotopy automorphism space $\mathbf{hAut}_{\mathcal{T}_{op} \circ \mathcal{P}}(\hat{D}_{2+})$ associated to the rationalization of D_2 , and in the unitary operad context, which we mark by the addition of the lower-script $+$ in our notation. Recall that the connected components of this space $\mathbf{hAut}_{\mathcal{T}_{op} \circ \mathcal{P}}(\hat{D}_{2+})$ correspond to homotopy classes of operad homotopy equivalences $f : \hat{Q}_{2+} \xrightarrow{\sim} \hat{Q}_{2+}$, where \hat{Q}_2 denotes a cofibrant model of the rationalized little 2-discs operad \hat{D}_2 . In our study, we just focus on the subspace $\mathbf{hAut}_{\mathcal{T}_{op} \circ \mathcal{P}}^1(\hat{D}_{2+})$ formed by the connected components of $\mathbf{hAut}_{\mathcal{T}_{op} \circ \mathcal{P}}(\hat{D}_{2+})$ which are associated to morphisms f inducing the identity on homology groups. The whole group $\pi_0 \mathbf{hAut}_{\mathcal{T}_{op} \circ \mathcal{P}}(\hat{D}_{2+})$ is actually a semi-direct product of $\pi_0 \mathbf{hAut}_{\mathcal{T}_{op} \circ \mathcal{P}}^1(\hat{D}_{2+})$ with a copy of the multiplicative group \mathbb{Q}^\times . Our result reads:

THEOREM A. *The automorphism space of the rational pro-nilpotent completion of the little 2-discs operad \hat{D}_{2+} satisfies*

$$\pi_* \mathbf{hAut}_{\mathcal{T}_{op} \circ \mathcal{P}}^1(\hat{D}_{2+}) = \begin{cases} GT^1(\mathbb{Q}), & \text{for } * = 0, \\ 0, & \text{otherwise,} \end{cases}$$

where $GT^1(\mathbb{Q})$ denotes the rational pro-unipotent version of the Grothendieck-Teichmüller group, as defined by V. Drinfeld in [48].

The identity established in this theorem is a new result. The ultimate goal of this work precisely consists in proving this statement.

The superscript in the notation $GT^1(\mathbb{Q})$ refers, as in the expression of the homotopy automorphism space $\mathbf{hAut}_{\mathcal{J}_{op} \circ_p}^1(\hat{D}_{2+})$, to a version of the Grothendieck-Teichmüller group where a multiplicative group factor \mathbb{Q}^\times is removed (see [48]).

At the beginning of this survey, we explained that the operad of little 2-discs D_2 consists of Eilenberg-MacLane spaces $K(P_r, 1)$, where P_r denotes the pure braid group on r strands, and the associated rationalized operad \hat{D}_2 consists of Eilenberg-MacLane spaces $K(\hat{P}_r, 1)$, where we now consider the Malcev completion of the group P_r . We have a standard model of the Eilenberg-MacLane spaces $K(P_r, 1)$, given by the classifying spaces of the groups P_r . But these spaces do not form an operad. Nevertheless, we can adapt this classifying space approach to give a simple model of E_2 -operad. Instead of the pure braid group P_r , we consider the classifying space of a groupoid of parenthesized braids $\mathbf{PaB}(r)$. The morphisms of this groupoid are braids on r strands indexed by elements of the set $\{1, \dots, r\}$. The parenthesization refers to an extra structure, added to the contact points of the braids, which define the object sets of our groupoid. Unlike the pure braid groups P_r , the collection of groupoids $\mathbf{PaB}(r)$ forms an operad in the category of groupoids, and the associated collection of classifying spaces $\mathbf{B}(\mathbf{PaB})(r) = \mathbf{B}(\mathbf{PaB}(r))$ forms an operad in topological spaces. We check, by relying on an argument of Z. Fiedorowicz, that this operad $\mathbf{B}(\mathbf{PaB})$ is a model of E_2 -operad.

For the rationalized operad of little 2-discs \hat{D}_2 , we also have a simple classifying space model $\mathbf{B}(\widehat{\mathbf{PaB}})$, where we consider an operad $\widehat{\mathbf{PaB}}$ formed by applying a Malcev completion construction to the groupoids $\mathbf{PaB}(r)$ underlying the parenthesized braid operad.

The Grothendieck-Teichmüller group $GT^1(\mathbb{Q})$ can actually be identified with an automorphism group associated with (a unitary extension of) this operad in groupoids $\widehat{\mathbf{PaB}}$, and an automorphism of topological operad $\mathbf{B}\phi : \mathbf{B}(\widehat{\mathbf{PaB}})_+ \xrightarrow{\cong} \mathbf{B}(\widehat{\mathbf{PaB}})_+$ can be associated to any element in this group $\phi \in GT^1(\mathbb{Q})$ by functoriality of the classifying space construction. This automorphism lifts to a homotopy automorphism $\widetilde{\mathbf{B}\phi} : \hat{Q}_2 \xrightarrow{\cong} \hat{Q}_2$ on any chosen cofibrant model \hat{Q}_2 of the rationalized operad of little 2-discs \hat{D}_2 , so that we have a well-defined rational homotopy automorphism of E_2 -operad associated to our element $\phi \in GT^1(\mathbb{Q})$. Our main theorem precisely asserts that this construction gives exactly all homotopy automorphism classes of E_2 -operads over the rationals.

We know, when we forget about operad structures, that the group of homotopy automorphism classes of the classifying space BG of a discrete group G is identified with the outer automorphism group $\text{Out}(G)$. But we are not able to follow this approach in our setting, though our operad has a model of this form $\mathbf{B}(\widehat{\mathbf{PaB}})$ where we just consider the discrete groupoids $\widehat{\mathbf{PaB}}(r)$ instead of discrete groups. Let us insist that we need a cofibrant model of E_2 -operad in order to define our group of homotopy automorphism classes. If we apply standard cofibrant replacement constructions to the operad $\mathbf{B}(\widehat{\mathbf{PaB}})$, then we still get a rational cofibrant model of E_2 -operad consisting of classifying spaces $\mathbf{B}(\text{Res}_\bullet \widehat{\mathbf{PaB}}(r))$, for a certain operad in groupoids $\text{Res}_\bullet \widehat{\mathbf{PaB}}$, but the groupoids underlying this operad $\text{Res}_\bullet \widehat{\mathbf{PaB}}(r)$ are no longer discrete, and we have no insight that a model, which would be both cofibrant

and formed by classifying spaces of discrete groupoids, exists for the operad of little 2-discs (over the rationals). Most of this work is therefore devoted to the development of new methods from which we establish the result of Theorem A.

We actually gain our result at the level of a category of cosimplicial Hopf cooperads $c\mathcal{H}opf\mathcal{O}p_*^c$, which we introduce as a suitable analogue of Sullivan's model for the rational homotopy of operads. The theorem which we obtain in this context is also worth recording in view towards algebraic applications of E_2 -operads.

The superscript c in the notation of this category $c\mathcal{H}opf\mathcal{O}p_*^c$ refers to cooperads. The subscript $*$ refers to an adaptation of the definition of unitary structures in the cooperad context. The prefix c marks cosimplicial structures. Just say, for the moment, that a cooperad is a structure \mathcal{C} , dual to an operad, which essentially consists of a collection of objects of the base category $\mathcal{C}(r) \in \mathcal{M}$ together with a comultiplicative structure of a form opposite to the composition operations of an operad. The cosimplicial Hopf cooperads \mathcal{C} , which we consider in our study, are cooperads in the category of cosimplicial unitary commutative algebras over \mathbb{Q} , and the collection $\mathcal{C}(r)$ underlying such a cooperad consists of objects in this category $\mathcal{M} = c\mathcal{C}om_+$.

In the usual Sullivan model for the rational homotopy of topological spaces, we deal with differential graded commutative algebras rather than cosimplicial commutative algebras. In the operadic context, we delay the application of differential graded constructions in order to work out difficulties arising from the Eilenberg-Zilber equivalence and the general problem of constructing the model of multiplicative structures on spaces.

To an operad in topological spaces P , we can associate the collection of singular complexes $\mathbf{Sing}_\bullet(P(r))$ of the topological spaces underlying P , which forms an operad in simplicial cocommutative coalgebras $\mathbf{Sing}_\bullet(P)$ (a simplicial Hopf operad for short). To define our model for the rational completion of P , we take $\mathbb{k} = \mathbb{Q}$ as coefficient ring for the singular complexes, and we form a dual construction assigning a cosimplicial Hopf cooperad $\mathbf{Sing}_\#^\bullet(P)$ to P . The obvious dual of the singular complex does not work, because this functor from spaces to cosimplicial modules preserves multiplicative structures up to homotopy only, and we need more rigidity in our construction. The idea is to define a contravariant functor $\mathbf{Sing}_\#^\bullet(-) : \mathcal{T}op\mathcal{O}p_*^{op} \rightarrow c\mathcal{H}opf\mathcal{O}p_*^c$ by adjunction from the singular complex functor $\mathbf{Sing}_\bullet(-) : P \mapsto \mathbf{Sing}_\bullet(P)$, where we regard the Hopf operad $\mathbf{Sing}_\bullet(P)$ associated to any $P \in \mathcal{T}op\mathcal{O}p_*$ as a whole. The mark $\#$ in our notation refers to this operadic upgrade of the dual singular complex construction.

We define a functor from cosimplicial Hopf cooperads to topological operads $\mathbf{G}(-) : c\mathcal{H}opf\mathcal{O}p_*^c \rightarrow \mathcal{T}op\mathcal{O}p_*^{op}$, and we prove that, under mild finiteness assumptions, the image of the cosimplicial Hopf cooperad $\mathbf{Sing}_\#^\bullet(P)$ under a left derived functor of $\mathbf{G}(-)$ returns a topological operad $\hat{P} = \mathbf{L}\mathbf{G}(\mathbf{Sing}_\#^\bullet(P))$ connected to P by a morphism (in the homotopy category of operads) inducing the rationalization on homotopy groups. Thus, the composite construction $\hat{P} = \mathbf{L}\mathbf{G}(\mathbf{Sing}_\#^\bullet(P))$ gives a suitable model for the rationalization process in the category of topological operads.

From this result, we essentially retain that the rational completion of a topological operad is naturally built on its Hopf cooperad counterpart, and this gives our actual reason to address rational homotopy problems about operads in the Hopf cooperad context.

The category $c\mathcal{H}opf\mathcal{O}p_*^c$ inherits a model structure, like the category of topological operads, so that we can apply the general theory of model categories to define groups of homotopy automorphism classes $\mathbf{Aut}_{\mathbf{Ho}(c\mathcal{H}opf\mathcal{O}p_*^c)}(A)$, as well as homotopy automorphisms spaces $\mathbf{hAut}_{c\mathcal{H}opf\mathcal{O}p_*^c}(A)$, for any object $A \in c\mathcal{H}opf\mathcal{O}p_*^c$. In the case of topological operads, we already mentioned that homotopy automorphisms spaces are well defined for cofibrant objects only. In the case of cosimplicial Hopf cooperads, we have to consider both cofibrant and fibrant replacements before applying the homotopy automorphism construction.

The results obtained in our study of the rational homotopy of operads imply that the group of homotopy automorphisms attached to the model $\mathbf{Sing}_\#^\bullet(P)$ of an operad in spaces P is isomorphic to the group of homotopy automorphisms attached to the rational completion of this operad \hat{P} . We actually have a homotopy equivalence, defined at the level of homotopy automorphism spaces, and underlying this isomorphism of groups of homotopy automorphism classes. Thus, homotopy automorphisms of rationalized operads are computable at the level of Hopf cooperads.

For the little 2-discs operad $P = D_2$, the object $\mathbf{Sing}_\#^\bullet(D_2)$ gives a reference model of E_2 -cooperad in cosimplicial commutative algebras. For our study, we may consider another model. Indeed, we can use the already considered groupoids of parenthesized braids $PaB(r)$ to form a cosimplicial Hopf E_2 -cooperad $\mathbf{C}^\bullet(\widehat{PaB})$ on which the Grothendieck-Teichmüller group acts (contravariantly). In short, this cooperad is formed by taking continuous duals of the simplicial complexes naturally associated to the groupoids $PaB(r)$. In the general introduction of this work, we mention that we have another small model of the little 2-discs operad D_2 formed by the cochain complex of certain Lie algebras, the Drinfeld-Kohno Lie algebras. These Lie algebras actually represent an infinitesimal counterpart of the structures defined by the pure braid groups. We also use this model to define appropriate approximations of the parenthesized braid operad.

We obtain:

THEOREM B. *Let Q_2 be a cofibrant and fibrant replacement of the cosimplicial Hopf cooperad $\mathbf{Sing}_\#^\bullet(D_2)$ (or of any model of cosimplicial Hopf E_2 -cooperad). The homotopy automorphism space associated to this cooperad has trivial homotopy groups*



$$\pi_*(\mathbf{hAut}_{c\mathcal{H}opf\mathcal{O}p_*^c}^1(Q_2)) = 0$$

in dimension $$ ≥ 0 , and the action of the Grothendieck-Teichmüller group $GT^1(\mathbb{Q})$ on parenthesized braids lifts to an isomorphism*

$$GT^1(\mathbb{Q})^{op} \xrightarrow{\cong} \pi_0(\mathbf{hAut}_{c\mathcal{H}opf\mathcal{O}p_*^c}^1(Q_2))$$

in dimension $$ $= 0$.*

The assertions of this theorem have been foreseen by M. Kontsevich in [104]. First results in the direction of Theorem B also occur in articles of D. Tamarkin [170] and T. Willwacher [179]. But these authors deal with operads within the category of differential graded modules, forgetting about Hopf structures, and their result actually give a stable version (in the sense of homotopy theory) of our statements. The definition of a setting, where we can combine a model for operadic structures and a commutative algebra model for the topology underlying our objects, is a new contribution of this monograph. The proof of Theorem B in this context is

also a new outcome of our work, like the result of Theorem A. In fact, we deduce Theorem A from the statement of Theorem B, by using our rational homotopy theory of operads.

Recall that E_2 -operads only give the second layer of a full sequence of homotopy structures, ranging from E_1 , fully homotopy associative but non-commutative, up to E_∞ , fully homotopy associative and commutative. The group of homotopy automorphism classes of E_1 -operads can easily be determined, but the result is trivial in this case. The group of homotopy automorphisms of an E_∞ -operad is trivial too (and so does the group of homotopy automorphisms of an E_∞ -cooperad). The open question is to define analogues of the Grothendieck-Teichmüller group for E_n -operads when $2 < n < \infty$.

To prove our theorem, we adapt constructions of [33, 35] in order to form a spectral sequence $E_s^2 = \mathbb{H}^s(\text{HopfDfm}_{\mathcal{O}_p}^c(\mathbb{H}^*(A), \mathbb{H}^*(B))^{\bullet}) \Rightarrow \pi_*(\text{Map}_{c\mathcal{H}opf\mathcal{O}_{p_*}^c}(A, B))$ computing the homotopy of mapping spaces in the category of cosimplicial Hopf cooperads $\text{Map}_{c\mathcal{H}opf\mathcal{O}_{p_*}^c}(A, B)$ from the cohomology of a deformation complex of graded Hopf cooperads. For the cohomology of the little 2-discs operad $\mathbb{H}^*(D_2)$, the cohomology of this Hopf deformation complex vanishes in degree $* > 0$ and is identified with a graded version of the Grothendieck-Teichmüller Lie algebra \mathfrak{grt} in degree $* = 0$. We check that all classes of degree $* = 0$ in the E^2 -term of our spectral sequence are hit by an actual homotopy automorphism, coming from the Grothendieck-Teichmüller group, to conclude that the spectral sequence degenerates at E^2 -stage and to obtain the result of our theorem.

As the reader sees, the proof of our result requires the complete setting up of new theories, like the definition of a model for the rational homotopy of topological operads. This issue was our first motivation to write a full monograph. Besides, for mathematicians coming from other domains and graduate students, we have wished to give a comprehensive introduction to our subject, heading to our main theorems as straight as possible and with minimal background.

We heavily use the formalism of Quillen's model categories [143] which we apply to operads in order to form our model for the rational homotopy of topological operads. For background material on Quillen's model categories, we rely on the modern references: Hirschhorn [88] and Hovey [89]. For rational homotopy theory, we refer to Bousfield-Gugenheim' memoir [34] which involves a model category approach close to our needs, and to the book [54] for a more comprehensive introduction of the subject. We also refer to Sullivan's seminal article [166] for the applications of rational homotopy theory to the study of homotopy automorphisms of spaces.

We give a comprehensive introduction to these subjects before tackling our own constructions. We first explain the connections between little 2-discs operads, braided operads, and Grothendieck-Teichmüller theory, as they arise from the works of Fiedorowicz [56], Tamarkin [170, 171], and Kontsevich [104]. We give a comprehensive account of these topics in the first volume of this monograph, after an introduction to the general theory of operads. We address the applications of deformation complexes to operads in the second volume, after a comprehensive introduction to the methods of homotopical algebra, the rational homotopy theory, and the definition of our model for the rational homotopy of operads. We complete the proof of our main results afterwards, in the concluding part of the second volume.

Contents

I. From operads to Grothendieck-Teichmüller groups. The first volume of this work includes a comprehensive introduction to the fundamental concepts of operad theory, a survey chapter on little discs and E_n -operads, a detailed study of the connections between little 2-discs and braids, an introduction to the theory of Hopf algebras and the Malcev completion of groups, and a report on the definition of the Grothendieck-Teichmüller group from the viewpoint of the theory of algebraic operads. We conclude this part with the definition of a map from the pro-unipotent Grothendieck-Teichmüller group towards the group of homotopy automorphism classes of the rationalization of the little 2-disc operad. The proof that this map defines an isomorphism gives the subject matter of the second volume.

Part 0. The general theory of operads. We first give an account on the general theory of operads. We devote this preliminary part of the volume to this purpose.

Chapter 1. The basic concepts of the theory of operads. In this chapter, we explain the definition of the notion of an operad (§1.1), we examine the application of usual categorical constructions to operads (§1.2), and we study the categories of algebras associated to operads (§1.3). In an appendix section (§1.4), we also recall the definition of particular instances of colimits (filtered colimits and reflexive coequalizers) which we heavily use in the operad context.

Chapter 2. Operads in symmetric monoidal categories. The second chapter of the part is devoted to recollections on symmetric monoidal category concepts and their applications to operads. We examine the definition of operads in general symmetric monoidal categories first (§2.1). We address the definition of operads in counitary cocommutative coalgebras as instances of the general notion of an operad in a symmetric monoidal category afterwards (§2.2).

We use the expression of a Hopf operad to refer to this category of operads in counitary cocommutative coalgebras. The Hopf cooperads, considered in the summary of our mathematical objectives, are the dual structures of these objects.

We heavily use the notion of an algebra and of a coalgebra in a symmetric monoidal category throughout this chapter, and we devote a preliminary section (§2.0) to an introduction of this subject. We also devote an appendix (§2.3) to recollections on various notions of functors associated to symmetric monoidal categories.

Chapter 3. The definition of operadic composition structures revisited. We actually have several equivalent definitions for the notion of an operad. In §1, we just recalled May's definition, which is perfectly well suited for an introduction of the subject and for the study of algebras associated to operads, but to work with operads themselves, we need another definition, giving more insights into the internal

structures of our objects, and we devote this third chapter to this matter. Recall that an operad intuitively consists of a full collection of operations associated with a category of algebras. In a first step (§3.1), we examine the multiplicative structure which models the composition of operations in an operad, and we check that this multiplicative structure is, according to an observation of M. Markl, fully determined by composition operations on two factors, usually called partial composition products in the operad literature. In a second part (§§3.2-3.4), we explain a reduced definition of operads that govern algebra structures equipped with a prescribed unit operation (the unitary operads).

In general, we assume that an operad consists of a sequence of terms $P(r)$, indexed by non-negative integers $r \in \mathbb{N}$, and whose elements intuitively represent operations with r inputs indexed by the ordinal $\underline{r} = \{1 < \dots < r\}$. To complete the account of this third chapter, we explain an extension of the definition of an operad where terms $P(\underline{r})$ indexed by arbitrary finite sets $\underline{r} = \{i_1, \dots, i_r\}$ are considered (§3.5). In general, we can use bijections $\{1 < \dots < r\} \xrightarrow{\cong} \{i_1, \dots, i_r\}$ to make the indexing by an arbitrary finite set $\{i_1, \dots, i_r\}$ equivalent to an indexing by an ordinal $\{1 < \dots < r\}$. Nevertheless, certain constructions on operads produce operations with no canonical input numbering, and the extension of the input indexing to arbitrary finite sets becomes useful in this case. (The construction of the free operad in §II.A gives a motivating application of this concept.)

Part 1. Braids and E_2 -operads. The main purpose of this part is to explain the general definition of an E_n -operad, starting with the model of the little n -discs, and in the case $n = 2$, to study the connection between Artin's braid groups and E_2 -operads.

Chapter 4. The little discs model of E_n -operads. This chapter includes: an introductory section on the definition of little n -discs operads and E_n -operads (§4.1); a survey section on the computation of the cohomology and homology of the little n -discs operads (§4.2); an outlook section, where we give an overview of several variants of the little discs operads (§4.3); and an appendix section (§4.4), where we fix some conventions on graded modules.

Chapter 5. Braids and the recognition of E_2 -operads. This chapter includes: an introductory section on basic concepts of Artin's braid theory (§5.0); an account on Fiedorowicz's definition of models of E_2 -operads from contractible operads endowed with an action of braid groups (§5.1); the definition of the colored braid operad, an operad in groupoids whose classifying spaces give a working model of an E_2 -operad (§5.2); a section on the fundamental groupoid of topological operads, where we reinterpret the definition of the colored braid operad from a topological viewpoint (§5.3); and an outlook section on the recognition of E_n -operads for $n > 2$ (§5.4).

Chapter 6. The magma and parenthesized braid operad. In our introductory chapter, we recall a general correspondence between operads and categories of algebras. In the case of an operad in small categories (or groupoids), like the operad of colored braids considered in §5, the algebras are objects of the category of small categories, and our operad therefore governs a class of monoidal structures which can be associated to a category. The operad of colored braids of §5 encodes the structure defining a strict braided monoidal category, where we have a tensor product which is associative in the strict sense. The main purpose of this chapter is

to explain the definition of a variant of the colored braid operad, the operad of parenthesized braids, associated to general braided monoidal category structures.

We first give a definition of an operad governing general monoidal categories (where the tensor product is associative up to isomorphism) by elaborating on the classical Mac Lane Coherence Theorem, of which we give an operadic interpretation (§6.1). We address the definition of the operad of parenthesized braids afterwards (§6.2).

Part 2. Completions and Grothendieck-Teichmüller groups. The main goal of this part is to explain the definition of the pro-unipotent Grothendieck-Teichmüller group as a group of automorphisms associated to a Malcev completion of the parenthesized braid operad of §6. We first give a comprehensive survey of the theory of Hopf algebras, on which we rely for the definition of the Malcev completion process for groups. We then explain an extension of this Malcev completion to groupoids and operads, and we devote the concluding chapter of the part to the study of the Grothendieck-Teichmüller groups themselves.

Chapter 7. Hopf algebras. This first chapter of the part includes: an introductory section, where we recall the general definition of a Hopf algebra (§7.1); comprehensive recollections on the classical structure theorems of the theory of Hopf algebras, namely the Poincaré-Birkhoff-Witt and the Milnor-Moore Theorem (§7.2); and an in-depth study of the structure of Hopf algebras in complete filtered modules (§7.3).

Chapter 8. The Malcev completion for groups. This chapter includes: a general definition of a category of Malcev complete groups, which makes sense for an arbitrary coefficient field of characteristic zero (§§8.1-8.2); a study of the Malcev completion of free groups and of groups defined by generators and relations (§8.3), and a proof of the identity between our category of Malcev complete groups and the category of uniquely divisible pro-nilpotent groups in the rational coefficient case (8.4).

Chapter 9. The Malcev completion for groupoids and operads. The Hopf algebras of §7 can be identified with group objects in the category of counitary cocommutative algebras. In this chapter, we introduce a generalization of this notion (§9.1) in order to extend the Malcev completion process of the previous chapter from groups to groupoids (§9.2). Then we check that this Malcev completion functor on groupoids preserves symmetric monoidal category structures, and as a consequence, gives rise to a Malcev completion functor on the category of operads in groupoids (§9.3).

Chapter 10. The definition of the Grothendieck-Teichmüller group. We give an operadic definition of the Grothendieck-Teichmüller group in this chapter. In the first instance (§10.1), we review the definition of the pro-unipotent group $GT^1(\mathbb{Q})$, considered in the statement of our main theorem in the foreword. We precisely prove that this group, as defined by V. Drinfeld, can be identified with a group of operad automorphisms associated to the Malcev completion of the operad of parenthesized braids of §6. In a second step (§10.2), we revisit the definition of the torsor of Drinfeld's associators, which we regard as a set of operad isomorphisms connecting the operad of parenthesized braids to an infinitesimal version of this operad, the operad of chord diagram, of which we also give the detailed definition. The expression of chord diagram, in this context, refers to a graphical representation of monomials occurring in the universal enveloping algebras of the

Drinfeld-Kohno Lie algebras. To complete our account, we revisit the definition of a graded version of the Grothendieck-Teichmüller group $GRT^1(\mathbb{Q})$ also introduced by V. Drinfeld in addition to the pro-unipotent group $GT^1(\mathbb{Q})$. We precisely check that this group $GRT^1(\mathbb{Q})$ is nothing but the group of automorphisms of the chord diagram operad (§10.3).

We conclude the chapter with an overview of the definition of the Knizhnik-Zamolodchikov associator, the first instance of an associator effectively constructed in the literature, which was also introduced by V. Drinfeld in his study of the Grothendieck-Teichmüller group (§10.4).

Recapitulation and outlook. The main purpose of this short part is to recap the statements established in this volume in view towards the achievement of our main mathematical objective, the setting up of a homotopy interpretation of the Grothendieck-Teichmüller group.

The homotopy interpretation of the Grothendieck-Teichmüller group. We mainly make explicit the map from the pro-unipotent Grothendieck-Teichmüller group towards the group of homotopy automorphisms associated to a rational model of E_2 -operad. The definition of the Grothendieck-Teichmüller group in §10 is purely algebraic. We just apply the usual classifying space construction and the interpretation of the little 2-discs spaces as Eilenberg-Mac Lane spaces associated to the pure braid groups in order to go back to the topological setting. We need more background on the homotopy of operads in order to prove that our mapping gives all homotopy classes of homotopy automorphisms associated to the rationalization of E_2 -operads. This subject matter is the purpose of the second volume.

The Grothendieck program. To conclude volume I, we also provide a brief introduction to the Grothendieck program in Galois theory, and an overview of the literature about the connections between Grothendieck-Teichmüller groups, motivic Galois groups, and polyzetas.

II. Homotopy of operads and deformation complexes. In this second volume, we set up general methods for the study of the (rational) homotopy of operads in spaces, and we give the proof of our main result: the pro-unipotent Grothendieck-Teichmüller group is isomorphic to the group of homotopy automorphism classes of the rationalization of the little 2-disc operad.

Part 0. Homotopical algebra methods. We first provide an introduction to fundamental concepts of the theory of model categories, the formalism introduced by Quillen to give a sense to the notion of a homotopy and of a homotopy category in a general setting.

Chapter 1. Model categories and homotopy categories. The first chapter of this part includes: an introductory section about the problem of defining homotopy categories (§1.0); a comprehensive account on the axioms of model categories (§1.1); the definition of the homotopy category of a model category (§1.2); a study of mapping spaces and homotopy automorphism spaces in the setting of model categories (§1.3); and an introduction to the application of model categories in the operadic context (§1.4).

Chapter 2. Cofibrantly generated model categories. This chapter is devoted to the notion of a cofibrantly generated model category, an abstract setting where we have an analogue of the cell approximations of topology. The chapter includes: a section about the abstract notion of a cell complex in general model

categories (§2.1); a section about the idea of cofibrant generation, which elaborates on the model category axioms and gives an effective approach for the definition of model category structures (§2.2); an account on the application of cofibrantly generated model structures for the definition of model structures by adjunction from a reference model category (§2.3).

Part 1. The rational homotopy of operads. The aim of this part is to give a detailed proof of the definition of a model structure on the category of operads in simplicial sets, and to explain the definition of a model for the rational homotopy of operads. For our purpose, we also revisit the definition of the classical Sullivan model for the rational homotopy of spaces.

Chapter 3. Models for the homotopy of operads in simplicial sets. To start with, we address the definition of a suitable model structure for the category of operads in simplicial sets. We actually consider two model structures. The first model structure, the one usually given in the literature, will be used in the context of non-unitary operads (operads governing non-unitary algebra structures). The second one, which we introduce in this monograph and call the Reedy model structure, is more appropriate for unitary operads (operads governing algebras with unit), and will be used in this context. We define the model structure on non-unitary operads first (§§3.1-3.2) and the Reedy model structure on unitary operads afterwards (§§3.3-3.4). In each case, we use a general adjunction process (recalled in §2.3) to deduce the definition of our model structure on operads from the definition of a model structure on a category of collections underlying our operads.

To complete the account of this chapter, we explain the application of a general construction of simplicial resolutions, the cotriple resolution, for the definition of cofibrant replacements in the category of operads in simplicial sets (§3.5).

Chapter 4. Models for the rational homotopy of spaces. Before studying the rational homotopy operads, we revisit the definition of the usual Sullivan model for the rational homotopy of spaces. The model of a space consists of a differential graded commutative algebra, yielded by a version with rational coefficients of the classical de Rham cochain complex of differential forms. In order to extend the rational homotopy of spaces to operads, we need a cosimplicial analogue of the Sullivan model, and we therefore study in detail a cosimplicial version of Sullivan's theory.

The plan of this chapter accordingly includes: a preliminary section about the definition of a cofibrantly generated model structure on the category of differential graded modules (§4.1); comprehensive recollections on (a cosimplicial version of) the Dold-Kan equivalence, between cosimplicial and differential graded modules, and the correlative definition of a cofibrantly generated model structure on the category of cosimplicial modules (§4.2); an account on the Eilenberg-Zilber equivalence, which formalizes the correspondence of symmetric monoidal structures between the category of cosimplicial modules and the category of differential graded modules (§4.3); the definition of a model structure on commutative algebras in differential graded (respectively, cosimplicial) modules by adjunction from the underlying category of differential graded (respectively, cosimplicial) modules (§4.4); and at last, the application of the model category of cosimplicial commutative algebras to the definition of our model for the rational homotopy of spaces (§4.5).

Chapter 5. Models for the rational homotopy of operads. The purpose of this chapter is to define our model for the rational homotopy of operads. Our construction elaborates on (our cosimplicial version of) the Sullivan model of spaces. To be explicit, recall that our model of an operad in simplicial sets consists, as we explain in the description of our mathematical objectives, of a cooperad in the category of unitary commutative cosimplicial algebras (a cosimplicial Hopf cooperad in our terminology).

We devote a first section of the chapter to the definition of the notion of a cooperad in the general setting of symmetric monoidal categories (§5.1). We then explain the definition of a model structure on the category of cooperads in cosimplicial modules (§5.2), on the category of cooperads in unitary commutative cosimplicial algebras (§5.3), and we address the definition of an operadic version of the Sullivan model functor afterwards (§5.4).

The functor from spaces to unitary commutative cosimplicial algebras which gives our model for the rational homotopy of spaces in §4.5 does not preserve multiplicative structures and, as a consequence, does not carry operads to cooperads. This functor preserves multiplicative structures up to homotopy only. The main purpose of §5.4 is to explain the definition of an operadic upgrade of this cosimplicial algebra functor, a functor which fixes the multiplicativity defects, and which associates a cooperad in unitary commutative cosimplicial algebras to any operad in simplicial sets.

We conclude this chapter with an account on the definition of operadic mapping spaces at the level of our cosimplicial Hopf cooperad model of operads (§5.5).

Chapter 6. Models for the rational homotopy of unitary operads. In §5, we focus on the study of the rational homotopy of non-unitary operads. The goal of this sixth chapter is extend our model to unitary operads. For this aim, we use the Reedy model structure of §3. We address the definition of an analogue of this Reedy model structure for cooperads first, and we check afterwards that the functor, which gives our model of non-unitary operads in §5, extends to a homotopy preserving functor from the Reedy model category of unitary operads in simplicial sets towards the Reedy model category of unitary Hopf cooperads.

Chapter 7. The rational model of E_n -operads. To conclude the study of this part, we make explicit a cosimplicial Hopf cooperad model of the little 2-discs operad. We precisely prove that the cochain complexes of the Drinfeld-Kohno Lie algebras, of which we recalled the idea in the description of our mathematical objectives, form such a model. We will also explain, by elaborating on ideas of D. Tamarkin, that this result can be interpreted as a formality statement for our Sullivan model of the little 2-discs operad. The proof of this formality result relies on the existence of Drinfeld's associators. We actually get a mapping from the set of Drinfeld's associators to the set of formality weak-equivalences between our cosimplicial Hopf cooperad model of the little 2-discs operad and the cohomology of little 2-discs.

We conclude this chapter with a survey of similar formality results, holding for the higher little discs operads, and which arise from works of Kontsevich and Lambrechts-Turchin-Volic. We precisely check that the formality weak-equivalences defined by these authors in the chain complex setting can be upgraded to formality weak-equivalences for our cosimplicial Hopf cooperad models of operads.

Part 2. Operadic deformation complexes. This part of the volume is devoted to a study of deformation complexes. These objects give an approximation of the operadic mapping spaces which we aim to understand. To begin with, we explain the definition of cosimplicial operadic deformation complexes, which naturally occur in cosimplicial decompositions of mapping spaces. Then we explain a general reduction process with the aim of computing the homology of these complexes.

For the rational homotopy theory of operads, we are naturally lead to study deformation complexes of Hopf cooperads. But we will study more basic instances of deformation complexes before tackling this case: in each chapter, we examine the deformation complex of associative algebras and commutative algebras first, we address the case of cooperads afterwards, and we only examining the case of Hopf cooperads, where a commutative algebra and a cooperad structure are mixed together, at the end of our study.

Chapter 8. Cosimplicial deformation complexes. In this chapter, we address the definition of cosimplicial deformation complexes: for associative algebras and commutative algebras; for cooperads; and, at last, for Hopf cooperads. The deformation complex of Hopf cooperads is obtained by putting together the commutative algebra and cooperad constructions.

Chapter 9. Differential graded reductions. In this chapter, we address the definition of deformation complexes in the differential graded setting. We adopt the same plan as in the previous chapter: we introduce differential graded deformation complexes for associative algebras and commutative algebras first, for cooperads afterwards, and for Hopf cooperads at last. In each case, associative algebras, commutative algebras, cooperads, and Hopf cooperads, we define a comparison morphism between the cosimplicial and the differential graded versions of our deformation complexes. In each case, we prove that our comparison morphism induces an iso at the cohomology level, and we interpret this result a reduction of the cosimplicial deformation complexes, which we aim to compute, to differential graded objects.

Chapter 10. Koszul reductions and applications to E_n -operads. The deformation complexes of the Hopf cooperads considered in this book inherit extra weight decompositions because the commutative algebras defining our Hopf cooperads are naturally graded, with homogeneous generators in degree 1, and we have an analogous homogeneous structure when we regard the cooperad as a whole. The purpose of this chapter is to explain that, in good cases, the homology of the deformation complexes is located in certain top homogeneous components with respect to the extra weight grading. In this situation, the computation of the homology of our deformation complex reduces to the computation of the homology of a small complex, which is precisely formed from the top components of our weight decomposition. We explain this process in the context of commutative algebras, operads and cooperads first, and again, we get the case of Hopf cooperads afterwards, by putting together the commutative algebra and cooperad constructions.

The reduction to the small homogeneous complex does not give the right result in all cases. The class of good algebras (respectively, operads, cooperads) for which this reduction can be applied are called Koszul algebras (respectively, operads, cooperads) in the literature. Therefore, we coin the term of Koszul reduction to refer to this second step of our reduction process, occurring after the differential graded reduction examined in the previous chapter. The cohomology of an E_n -operad

gives an instance of a Hopf cooperad formed by a sequence of Koszul commutative algebras, and which is also Koszul as a cooperad.

In the concluding section of the chapter, we prove, by applying the Koszul reduction, that the deformation complex of the cohomology of little 2-discs, viewed as a Hopf cooperad, completely collapses in degree > 0 . In the next part, we will use intermediate results on deformation complexes of E_2 -operads rather than this latter outcome, because we need some finer computation to complete the determination of the homotopy automorphism space of the little 2-discs operad. On the other hand, the result obtained in the next part implies that all degree 0 classes in the deformation complex correspond to actual homotopy automorphisms of the little 2-discs operad over the rationals, and this observation is worth recording.

Part 3. Spectral Sequences for operadic mapping spaces. In general, the deformation complexes studied in the previous part only give, as previously mentioned, approximations of the mapping and automorphism spaces that one would like to determine. In this third part of the volume, we explain processes, encoded by spectral sequences, to determine the homotopy of an automorphism space from the computation of an associated deformation complex. The general background of these constructions is not new, but this book is the first work explicitly dealing with the application of these obstruction spectral sequences to Hopf cooperads.

Chapter 8. General obstruction theory for operads in spaces. To begin with, we review a general theory, due to Bousfield and Kan, for the construction of set-theoretic spectral sequences from cosimplicial spaces. By applying this general construction in the operad context, we obtain a spectral sequence computing the homotopy of an operadic mapping space from the cohomology of the operadic deformation complexes considered in the previous part. Recall that our homotopy automorphism spaces consist of invertible connected components of such mapping spaces.

In the case of an E_2 -operad, this spectral sequence collapses at the second stage, because the cohomology of the operadic deformation complex vanishes in degree > 0 when we take the full Hopf cooperad structure into account, and we can check that all classes of degree 0 correspond to actual morphisms. This latter verification requires a technical analysis of the correspondence between classes on the E^1 -page of the spectral sequence and morphisms on the abutment. For this aim, we need another spectral sequence construction which returns, from the second page, the same outcome as our general spectral sequence. This construction gives the subject matter of the next chapter.

Chapter 9. The Drinfeld-Kohno tower and the associated spectral sequence. In §I.5, we explain the definition of models of an E_2 -operad from categories of colored braids. In the rational context, we can use a rationalized version of the lower central series of braid groups to form a tower of operads with the Malcev completion of the little 2-discs operad as limit term. This tower of operads gives rise to a new spectral sequence, which we analyze completely in order to complete the proof of our result on the homotopy of the space of homotopy automorphisms of E_2 -operads.

Outlook. The initial motivation for the study of connections between Grothendieck-Teichmüller groups and E_2 -operads has been provided by works of D.

Tamarkin and M. Kontsevich on the deformation quantization problem. To conclude the book, we will give a short survey of applications of E_2 -operads in deformation quantization, following the work of these authors, and we will revisit Tamarkin's and Kontsevich's approaches, based on the theory of Drinfeld associators, for the construction of an action of the Grothendieck-Teichmüller group on the moduli space of deformation quantizations. To be more specific, we will give a homotopy theoretic interpretation of this group action by using our result on the homotopy automorphisms of E_2 -operads, and parallel results obtained by T. Willwacher [179] in the chain complex setting. Then we will give new motivations, arising from our own works on the cohomology of iterated loop spaces, for further research on the homotopy automorphisms of E_n -operads, where we now consider any $n \geq 2$.

Appendices. The appendices are devoted to the study of the structure of free operads and cofree cooperads. We crucially use the constructions of these appendices in our analysis of deformation complexes.

Appendix A. The construction of free operads. This appendix includes: a comprehensive account on the formalism of trees (§A.1), which is heavily used in operad theory; the definition of treewise tensor objects associated to operads (§A.2); the construction of free operads, in the general case first (§A.3), in the case of connected operad structures and unitary operads afterwards (§§A.4-A.5).

Appendix B. The connected free operad monad. In this appendix, we study composition structures associated with the free operad functor. To simplify, we restrict our analysis to connected operads. In §B.1, we introduce a notion of tree morphism, which we use afterwards, in §§B.2-B.3, to give a description of the two-fold composite of the free operad functor. The free operad functor inherits a monad structure, which, in abstract terms, consists of an associative monoid object structure in the composition category of functors. In §B.4, we give a description of this monadic multiplication, by using the result of the previous section, and we prove that the notion of an operad can be defined in terms of the free operad monad. In the language of category theory, this result asserts that the category of operads is monadic. To complete the account of this appendix, we also explain the definition of a simplicial resolution of operads, the cotriple resolution, from the monad structure of the free operad functor (§B.5).

Appendix C. The construction of cofree cooperads. In this appendix, we examine a dualization of the constructions of §§A-B with the aim of giving an explicit definition of cofree objects in the category of cooperads. In categorical terms, the dualization process implies the replacement of colimits by limits. This process creates difficulties since the tensor product, involved in all structure definitions, does not commute with all limits, and this problem can hardly be overcome in general. But, under our general connectedness assumption, we still have a simple construction of the cofree cooperad. In short, we observe that the categorical dualization can be performed incompletely when we deal with connected structures: we construct our cofree cooperad with the same underlying functor as the free operad, and with colimits yet, but we provide the obtained object with a cooperad coproduct structure instead of an operadic composition structure. The crux of our argument line lies in the observation that the colimits occurring in our construction reduce to finite coproducts. To be precise, this statement implies that our construction of the cofree cooperad returns the obvious cofree object when the ground category

is additive. In general, we still get a structure, which can serve to define cofree objects, but we do not get a cooperad in the obvious sense of the term.

In order to achieve our construction, we devote a preliminary section to a thorough analysis of operadic decomposition of trees, which we use in a second section to define the coproduct structure of the cofree cooperad. Then, to complete our results, we study a natural comonad structure on the cofree cooperad, dual to the monad structure considered in §B for the free operad, and we establish the dual of the result of §B.4 (the category of cooperads is comonadic).

Appendix D. The construction of cooperad pullbacks. In §§A-C, we study free operads and cofree cooperads in an absolute setting. The purpose of this short technical appendix is to give an effective construction of pushouts along morphisms of free objects in the category of operads, and an effective construction of pullbacks along morphisms cofree objects in the category of cooperads. We use these constructions in the verification of the model category axioms for operads in §3 and for cooperads in §§5-6.

Foundations and Conventions

The reader is assumed to be familiar with the language of category theory and to have basic knowledge about fundamental concepts (like adjoint and representable functors, colimits and limits, categorical duality), which we freely use throughout this work. The reader is also assumed to be aware on the applications of colimits and limits in basic examples of categories (including sets, topological spaces, and modules). Nonetheless, we will review some specialized topics, like reflexive coequalizers and filtered colimits, which are considered in applications of category theory to operads.

We use single script letters (like \mathcal{C} , \mathcal{M} , ...) as general notation for abstract categories. We use script expressions (like $\mathcal{M}od$, $\mathcal{A}s$, $\mathcal{O}p$, ...) for particular instances of categories (like modules, associative algebras, operads, ...). We soon explain that the formal definition of the higher structures remains the same in any instance of base category \mathcal{M} and essentially depends on a *symmetric monoidal structure* given with \mathcal{M} . We generally assume that the category \mathcal{M} , to which we assign the role of a base category, is equipped with enriched hom-bifunctors $\mathbf{Hom}_{\mathcal{M}}(-, -)$. We give more detail recollections on this notion in §§0.12-0.13.

In practice, we take our base category \mathcal{M} among the category of sets Set , the category of simplicial sets $Simp$, the category of topological spaces $\mathcal{T}op$, a category of \mathbb{k} -modules $\mathcal{M}od$ (where \mathbb{k} refers to a fixed ground ring), or a variant of these categories. To be precise, besides plain \mathbb{k} -modules, we have to consider categories formed by differential graded modules $dg\ \mathcal{M}od$ (we usually say *dg-modules* for short), graded modules $g\ \mathcal{M}od$, simplicial modules $s\ \mathcal{M}od$, and cosimplicial modules $c\ \mathcal{M}od$. The first purpose of this preliminary chapter is to quickly recall the definition of these categories (at least, in order to fix our conventions). By the way, we also recall the definition of the category of simplicial sets $Simp$, which we use along with the familiar category of topological spaces $\mathcal{T}op$.

To complete our account, we will recall the general definition of a symmetric monoidal category, and we explain some general constructions attached to this structure. The explicit definition of the monoidal category structure on dg-modules, simplicial modules, cosimplicial modules, is put off until we tackle the applications of these categories.

In the module context, we assume that a ground ring \mathbb{k} is given and fixed once and for all. In certain constructions, we have to assume that this ground ring \mathbb{k} is a field of characteristic 0.

0.1. *Graded and differential graded modules.* The category of differential graded modules $dg\ \mathcal{M}od$ (dg-modules for short) consists of \mathbb{k} -modules equipped with a decomposition $K = \bigoplus_{n \in \mathbb{Z}} K_n$, running over \mathbb{Z} , and with a morphism $\delta : K \rightarrow K$, the differential of K , such that $\delta^2 = 0$ and $\delta(K_n) \subset K_{n-1}$, for all $n \in \mathbb{Z}$. Naturally,

a morphism of dg-modules is a morphism of \mathbb{k} -modules $f : K \rightarrow L$ which commutes with differentials and satisfies $f(K_n) \subset L_n$, for all $n \in \mathbb{Z}$.

In textbooks of homological algebra (like [176]), authors mostly deal with the equivalent notion of chain complex, of which components are split off into sequences of \mathbb{k} -modules K_n connected by the differentials $\delta : K_n \rightarrow K_{n-1}$ rather than being put together in a single object. The idea of a dg-module (used for instance in [121]) is more natural for our purpose and is also more widely used in homotopy theory. Our convention is to keep the terminology of chain complex for specific constructions, like the normalized chain complex of simplicial sets, or the deformation complex attached an algebraic structure.

The category of graded modules $gMod$ consists of \mathbb{k} -modules equipped with a decomposition $K = \bigoplus_{n \in \mathbb{Z}} K_n$, running over \mathbb{Z} , but no differential. A morphism of graded modules is a morphism of \mathbb{k} -modules $f : K \rightarrow L$ such that $f(K_n) \subset L_n$, for all $n \in \mathbb{Z}$.

We have an obvious functor $(-)_b : dgMod \rightarrow gMod$ defined by retaining the single graded structure of dg-modules and forgetting about the differential. We consider the underlying graded module of dg-modules, which this forgetful process formalizes, when we address the definition of quasi-free objects. The other way round, we can embed the category of graded modules $gMod$ into the category of dg-modules $dgMod$, by viewing a graded module as a dg-modules equipped with a trivial differential $\delta = 0$. We use this identification at various places.

Recall that the homology of a dg-module K is defined by the quotient \mathbb{k} -module $H_*(K) = \ker \delta / \text{im } \delta$ which inherits a natural grading from K . The homology defines a functor $H_*(-) : dgMod \rightarrow gMod$. The morphisms of dg-modules which induce an isomorphism in homology are the weak-equivalences of the category of dg-modules. The expression of weak-equivalence actually refers to the general formalism of model categories. In most references of homological algebra, authors use the terminology of quasi-isomorphism rather than this expression of weak-equivalence.

We generally use the mark $\xrightarrow{\sim}$ to refer to the class of weak-equivalences in a model category (see §II.1) and we will naturally use the same notation in the dg-module context.

0.2. *Degrees and signs of dg-algebra.* The component K_n of a dg-module (respectively, graded module) K defines the homogeneous component of degree n of K . To specify the degree of a homogeneous element $x \in K_n$, we use the expression $\text{deg}(x) = n$. We adopt the standard convention of dg-algebra to associate a sign $(-1)^{\text{deg}(x)\text{deg}(y)}$ to each transposition of homogeneous elements (x, y) . We do not specify such a sign in general and we simply use the notation \pm to refer to it. We explain soon that the introduction of these signs is forced by the definition of the symmetry isomorphism of the tensor product of dg-modules.

We usually consider lower graded dg-modules, but we also have a standard notion of dg-module equipped with a decomposition in upper graded components $K = \bigoplus_{n \in \mathbb{Z}} K^n$ so that the differential satisfies $\delta(K^n) \subset K^{n+1}$. Certain constructions (like the duality of \mathbb{k} -modules and the conormalized complex of cosimplicial spaces) naturally produce upper graded dg-modules. In what follows, we apply the relation $K_{-n} = K^n$ to identify an upper graded with a lower graded dg-module.

0.3. *Simplicial and cosimplicial objects, simplicial and cosimplicial modules.* The simplicial category Δ , which models the structure of simplicial and cosimplicial objects, is defined by the collection of finite ordinals $\underline{n} = \{0 < \dots < n\}$, $n \in \mathbb{N}$, as

objects together with the non-decreasing maps $u : \{0 < \dots < m\} \rightarrow \{0 < \dots < n\}$ as morphisms. In short, a simplicial object X in a category \mathcal{C} is a contravariant functor $X : \Delta^{op} \rightarrow \mathcal{C}$ that assigns an object $X_n \in \mathcal{C}$ to each $n \in \mathbb{N}$ and a morphism $u^* : X_n \rightarrow X_m$ to each non-decreasing map u . Dually, a cosimplicial object in \mathcal{C} is a covariant functor $X : \Delta \rightarrow \mathcal{C}$ which assigns an object $X^n \in \mathcal{C}$ to each $n \in \mathbb{N}$ and a morphism $u_* : X^n \rightarrow X^m$ to each non-decreasing map u . Naturally, we define a morphism of simplicial objects $f : X \rightarrow Y$ (and a morphism of cosimplicial object similarly) as a sequence of morphisms $f : X_n \rightarrow Y_n$ in the ambient category \mathcal{C} commuting with the action of simplicial operators u^* on X and Y .

We generally use the expression $s\mathcal{C}$ to denote the category of simplicial objects in a given ambient category \mathcal{C} and the expression $c\mathcal{C}$ for the category of cosimplicial objects in \mathcal{C} . We only use a specific notation $Simp$ for the category of simplicial sets, which formally consists of the simplicial objects in the category of sets.

The simplices Δ^n , $n \in \mathbb{N}$, are the fundamental examples of simplicial sets, defined, as simplicial objects, by the representable functors $\text{Mor}_\Delta(-, \underline{n})$, where we use the notation $\text{Mor}_\Delta(\underline{m}, \underline{n})$ to refer to the morphism sets of the simplicial category Δ . The collection of n -simplices Δ^n , $n \in \mathbb{N}$, forms itself a cosimplicial object in the category of simplicial sets, with the covariant action of non-decreasing maps $u_* : \Delta^m \rightarrow \Delta^n$ defined by the composition on the target in the morphism set representation of Δ^n .

In the case of a simplicial set X , an element $\sigma \in X_n$ is called an n -dimensional simplex (or more simply, an n -simplex) in X . The definition of the n -simplex Δ^n as a morphism set $\Delta^n = \text{Mor}_\Delta(-, \underline{n})$ implies that we have the relation $\text{Mor}_{Simp}(\Delta^n, X) = X_n$, for any simplicial set $X \in Simp$, where we use the notation $\text{Mor}_{Simp}(-, -)$ for the morphism set of the category $Simp$. To make this correspondence explicit, we consider the n -simplex, denoted by $\Delta_n \in (\Delta^n)_n$, which corresponds to the identity of the object \underline{n} in the simplicial category Δ . The morphism $\sigma_* : \Delta^n \rightarrow X$, associated to any n -simplex $\sigma \in X_n$, is precisely characterized by the relation $\sigma_*(\Delta_n) = \sigma$.

The topological n -simplices $\Delta_{top}^n = \{(t_0, \dots, t_n) | 0 \leq t_i \leq 1, t_0 + \dots + t_n = 1\}$ form another fundamental instance of a cosimplicial object, defined in the category of topological spaces. The cosimplicial structure map $u_* : \Delta_{top}^m \rightarrow \Delta_{top}^n$ associated to any $u \in \text{Mor}_\Delta(\underline{m}, \underline{n})$ assigns an element $(s_0, \dots, s_m) \in \Delta_{top}^m$ to the point $(t_0, \dots, t_n) \in \Delta_{top}^n$ such that $t_i = \sum_{u(k)=i} s_k$.

0.4. *Faces and degeneracies in a simplicial object.* The maps $d^i : \{0 < \dots < n - 1\} \rightarrow \{0 < \dots < n\}$, $i = 0, \dots, n$, such that

$$(a) \quad d^i(x) = \begin{cases} x, & \text{for } x < i, \\ x + 1, & \text{for } x \geq i, \end{cases}$$

and the maps $s^j : \{0 < \dots < n\} \rightarrow \{0 < \dots < n + 1\}$, $j = 0, \dots, n$, such that

$$(b) \quad s^j(x) = \begin{cases} x, & \text{for } x \leq j, \\ x - 1, & \text{for } x > j, \end{cases}$$

generate the simplicial category in the sense that any non-decreasing map $u : \{0 < \dots < m\} \rightarrow \{0 < \dots < n\}$ can be written as a composite of maps of that form. Moreover, any relation between these generating morphisms can be deduced from

generating relations

$$(c) \quad \begin{aligned} d^j d^i &= d^i d^{j-1}, \text{ for } i < j, \\ s^j d^i &= \begin{cases} d^i s^{j-1}, & \text{for } i < j, \\ id, & \text{for } i = j, j+1, \\ d^{i-1} s^j, & \text{for } i > j, \end{cases} \\ s^j s^i &= s^i s^{j+1}, \text{ for } i \leq j. \end{aligned}$$

The structure of a cosimplicial object is, as a consequence, fully determined by a sequence of objects $X^n \in \mathcal{C}$ together with morphisms $d^i : X^{n-1} \rightarrow X^n$, $i = 0, \dots, n$, and $s^j : X^{n+1} \rightarrow X^n$, $j = 0, \dots, n$, for which these relations (c) hold. The morphisms $d^i : X^{n-1} \rightarrow X^n$, $i = 0, \dots, n$, which represent the image of the maps d^i under the functor defined by X , are the coface operators of the cosimplicial object X (in general, we simply say the cofaces of X). The morphisms $s^j : X^{n+1} \rightarrow X^n$, $j = 0, \dots, n$, which represent the image of the maps s^j are the codegeneracy operators of X (or, more simply, the codegeneracies of X).

Dually, the structure of a simplicial object is fully determined by a sequence of objects $X_n \in \mathcal{C}$ together with morphisms $d_i : X_n \rightarrow X_{n-1}$, $i = 0, \dots, n$, and $s_j : X_n \rightarrow X_{n+1}$, $j = 0, \dots, n$, for which relations

$$(d) \quad \begin{aligned} d_i d_j &= d_{j-1} d_i, \text{ for } i < j, \\ d_i s_j &= \begin{cases} s_{j-1} d_i, & \text{for } i < j, \\ id, & \text{for } i = j, j+1, \\ s_j d_{i-1}, & \text{for } i > j, \end{cases} \\ s_i s_j &= s_{j+1} s_i, \text{ for } i \leq j. \end{aligned}$$

opposite to (c) hold. The morphisms $d_i : X_n \rightarrow X_{n-1}$, $i = 0, \dots, n$, which represent the image of the maps d^i under the contravariant functor defined by X , are the face operators of the simplicial object X , and the morphisms $s_j : X_n \rightarrow X_{n+1}$, $j = 0, \dots, n$, which represent the image of the maps s^j , are the degeneracy operators of X .

0.5. *Topological realization of simplicial sets and singular complex of topological spaces.* Recall that a topological space $|K|$, traditionally called the geometric realization of K , is naturally associated to each simplicial set $K \in \mathit{Simp}$. This space is defined by the coend

$$|K| = \int^{n \in \Delta} K_n \times \Delta_{top}^n.$$

where each set K_n is viewed as a discrete space and we consider the topological n -simplices Δ_{top}^n (of which definition is recalled in §0.3). The coend process amounts to performing a quotient of the coproduct $\coprod_n K_n \times \Delta_{top}^n = \coprod_n \{ \coprod_{\sigma \in K_n} \{\sigma\} \times \Delta_{top}^n \}$ under relations of the form

$$(u^*(\sigma), (t_0, \dots, t_m)) \equiv (\sigma, u_*(t_0, \dots, t_m)),$$

for $u \in \mathit{Mor}_\Delta(\underline{m}, \underline{n})$, $\sigma \in K_n$, and $(t_0, \dots, t_m) \in \Delta_{top}^m$. The definition of the map $u_* : \Delta_{top}^m \rightarrow \Delta_{top}^n$ associated to each $u \in \mathit{Mor}_\Delta(\underline{m}, \underline{n})$ involves the cosimplicial structure of the topological n -simplices Δ_{top}^m . One easily checks that the realization of the n -simplex $\Delta^n = \mathit{Mor}_\Delta(-, \underline{n})$ is identified with the topological n -simplex Δ_{top}^n .

In the converse direction, we can use the singular complex construction to associate a simplicial set $\mathbf{Sing}_\bullet(X)$ to any topological space X . This simplicial set $\mathbf{Sing}_\bullet(X)$ consists in dimension n of the set of continuous maps $\sigma : \Delta_{top}^n \rightarrow X$ going from the topological n -simplex Δ_{top}^n to X . The composition of simplices $\sigma : \Delta_{top}^n \rightarrow X$ with the cosimplicial operator $u_* : \Delta_{top}^m \rightarrow \Delta_{top}^n$ associated to any $u \in \text{Mor}_\Delta(\underline{m}, \underline{n})$ yields a map $u^* : \mathbf{Sing}_n(X) \rightarrow \mathbf{Sing}_m(X)$ so that the collection of sets $\mathbf{Sing}_n(X) = \text{Mor}_{\mathcal{T}op}(\Delta_{top}^n, X)$, $n \in \mathbb{N}$, inherits a natural simplicial structure.

The geometric realization $|-| : K \mapsto |K|$ obviously gives a functor $|-| : \mathcal{Simp} \rightarrow \mathcal{T}op$. The singular complex construction gives a functor in the converse direction $\mathbf{Sing}_\bullet : \mathcal{T}op \rightarrow \mathcal{Simp}$, which is actually a right adjoint of the geometric realization functor $|-| : \mathcal{Simp} \rightarrow \mathcal{T}op$ (see [78, §I.2]).

0.6. *Simplicial modules, cosimplicial modules, and homology.* The category of simplicial modules $sMod$ is the category of simplicial objects in the category of \mathbb{k} -modules Mod . Thus, a simplicial module K can be defined either as contravariant functors from the simplicial category Δ to the category of \mathbb{k} -modules Mod , or, equivalently, as collections of \mathbb{k} -modules K_n , $n \in \mathbb{N}$ equipped with faces $d_i : K_n \rightarrow K_{n-1}$, $i = 0, \dots, n$, and degeneracies $s_j : K_n \rightarrow K_{n+1}$, $j = 0, \dots, n$, satisfying the simplicial relations.

The category of cosimplicial modules $cMod$ similarly consists of the cosimplicial objects in \mathbb{k} -modules.

To any simplicial module K , we associate a dg-module $N_*(K)$, called the normalized complex of K , and defined by the quotient $N_n(K) = K_n/s_0K_{n-1} + \dots + s_{n-1}K_{n-1}$ in degree n , together with the differential $\delta : N_n(K) \rightarrow N_{n-1}(K)$ such that $\delta = \sum_{i=0}^n (-1)^i d_i$. This normalized chain complex construction naturally gives a functor $N_* : sMod \rightarrow dgMod$. The homology of a simplicial module K is defined as the homology of the associated normalized complex $N_*(K)$. For simplicity, we use the same notation for the homology functor on simplicial modules and on dg-modules. Hence, we may write $H_*(K) = H_*(N_*(K))$, for any $K \in sMod$.

0.7. *Normalized complex and homology of simplicial sets.* We will consider the functor $\mathbb{k}[-] : \mathcal{Simp} \rightarrow sMod$ which maps a simplicial set X to the simplicial module $\mathbb{k}[X]$ generated by the set X_n in dimension n , for any $n \in \mathbb{N}$, and which inherits an obvious simplicial structure. We also have a contravariant functor $\mathbf{A}^\bullet : \mathcal{Simp}^{op} \rightarrow cMod$ which maps a simplicial set X to the cosimplicial module $\mathbf{A}^\bullet(X) = \mathbb{k}^X$, dual to $\mathbb{k}[X]$, and defined in dimension n by the collection of set-theoretic maps $u : X_n \rightarrow \mathbb{k}$.

We use the notation $N_*(X)$ for the normalized complex of the simplicial \mathbb{k} -module $\mathbb{k}[X]$ associated to a simplicial set X . We retrieve the classical homology of simplicial sets by considering the homology of these simplicial modules. We also use the notation $H_*(-)$ for the homology functor on simplicial sets, and we may write $H_*(X) = H_*(N_*(X))$, for any $X \in \mathcal{Simp}$.

The normalized complexes of the simplices Δ^n , $n \in \mathbb{N}$, naturally form a simplicial object in the category of dg-modules $N_*(\Delta^\bullet)$. For a given simplicial module K , we have a coend formula

$$N_*(K) = \int^{n \in \Delta} K_n \otimes N_*(\Delta^n),$$

and the normalized complex construction of §0.6 can be regarded as a dg-module version of the topological realization of simplicial sets.

0.8. *Symmetric monoidal categories and the structure of base categories.* In the introduction of this chapter, we mention that our base categories $\mathcal{M} = \mathit{Set}, \mathit{Top}, \mathit{Mod}, \dots$ are all instances of a symmetric monoidal categories.

By definition, a symmetric monoidal category is a category \mathcal{M} equipped with a tensor product $\otimes : \mathcal{M} \times \mathcal{M} \rightarrow \mathcal{M}$ satisfying natural unit, associativity and symmetry relations. These relations are expressed by structure isomorphisms which have to be given along with the category:

- (a) The unit is given by an object $\mathbb{1} \in \mathcal{M}$ together with a natural isomorphism $X \otimes \mathbb{1} \simeq X \simeq \mathbb{1} \otimes X$, associated to each $X \in \mathcal{M}$.
- (b) The associativity relation is given by a natural isomorphism $(X \otimes Y) \otimes Z \simeq X \otimes (Y \otimes Z)$, associated to every triple of objects $X, Y, Z \in \mathcal{M}$, satisfying a pentagonal coherence relation (Mac Lane's pentagon relation) and two additional triangular coherence relations with respect to the unit isomorphism (we refer to [122, §XI.1] for the expression of these constraints).
- (c) The symmetry relation is given by a symmetry isomorphism $X \otimes Y \simeq Y \otimes X$, associated to every pair of objects $X, Y \in \mathcal{M}$, satisfying hexagonal coherence relations (Drinfeld's hexagon relation) and two additional triangular coherence relations with respect to the unit isomorphism (see again [122, §XI.1] for details).

In the case of \mathbb{k} -modules Mod , the monoidal structure is given by the usual tensor product of \mathbb{k} -modules, taken over the ground ring, together with the ground ring itself as unit object. The definition of the tensor product of dg-modules, simplicial modules, cosimplicial modules is reviewed later on, when we tackle applications of these ground categories. In the category of sets Set (respectively, topological spaces Top , simplicial sets Simp), the tensor product is simply given by the cartesian product $\otimes = \times$ together with the one-point set $\mathbb{1} = pt$ as unit object. In what follows, we also use the general notation $*$ for the terminal object of a category, and we may write $pt = *$ when we want to stress that the one point-set actually represents the terminal object of the category of sets (respectively, topological spaces, or simplicial sets).

The unit object and the isomorphisms that come with the unit, associativity and commutativity relations of a symmetric monoidal category are part of the structure. Therefore, these morphisms have, in principle, to be given with the definition. But, in our examples, we can assume that the unit and associativity relations are identities, and usually, we just make explicit the definition of the symmetry isomorphism $c = c(A, B) : A \otimes B \xrightarrow{\simeq} B \otimes A$.

0.9. *Tensor products and colimits.* In many constructions, we consider symmetric monoidal categories \mathcal{M} equipped with colimits and limits and so that the tensor product of \mathcal{M} preserves colimits on each side. To be explicit, we use:

- (a) The canonical morphism $\text{colim}_{\alpha \in \mathcal{J}} (X_\alpha \otimes Y) \rightarrow (\text{colim}_{\alpha \in \mathcal{J}} X_\alpha) \otimes Y$ associated to a diagram $X_\alpha \in \mathcal{M}$, $\alpha \in \mathcal{J}$, is an iso for all $Y \in \mathcal{M}$, and similarly as regards the canonical morphism $\text{colim}_{\beta \in \mathcal{J}} (X \otimes Y_\beta) \rightarrow X \otimes (\text{colim}_{\beta \in \mathcal{J}} Y_\beta)$ associated to a diagram $Y_\beta \in \mathcal{M}$, $\beta \in \mathcal{J}$, where X is now a fixed object of \mathcal{M} .

This requirement is fulfilled by all categories which we take as base categories $\mathcal{M} = \mathit{Set}, \mathit{Top}, \mathit{Mod}, \dots$ and is required for the application of categorical constructions to operads and algebras over operads. The category of coalgebras, of which we recall the definition soon, satisfies (a) whenever the base category does, because colimits

of coalgebras are created in the underlying base category (see §I.2.0.3). On the other hand, we will also consider instances of categories which do not satisfy this colimit condition (a).

0.10. *Symmetric groups and tensor permutations.* We use the notation Σ_r for the group of permutations of $\{1, \dots, r\}$. Depending on the context, we regard a permutation $s \in \Sigma_r$ as a bijection $s : \{1, \dots, r\} \rightarrow \{1, \dots, r\}$, or as a sequence $s = (s(1), \dots, s(r))$, equivalent to an ordering on the set $\{1, \dots, r\}$. In any case, we will use the notation $id = id_r$ for the identity permutation in Σ_r . We drop the lower-script r , indicating the permutation cardinal, when we do not need to specify this information.

In a symmetric monoidal category equipped with a strictly associative tensor product, we can form r -fold tensor products $T = X_1 \otimes \cdots \otimes X_r$ without care, and drop unnecessary bracketings. Then we also have a natural isomorphism

$$X_1 \otimes \cdots \otimes X_r \xrightarrow{s^*} X_{s(1)} \otimes \cdots \otimes X_{s(r)},$$

associated to each permutation $s \in \Sigma_r$, and so that the standard unit and associativity relations $id^* = id$ and $t^*s^* = (st)^*$ hold. To construct this action, we use the classical presentation of Σ_r , with the transpositions $t_i = (i \ i + 1)$ as generating elements, and the identities

- (a) $t_i^2 = id, \quad \text{for } i = 1, \dots, n - 1,$
- (b) $t_i t_j = t_j t_i, \quad \text{for } i, j = 1, \dots, n - 1, \text{ with } |i - j| \geq 2,$
- (c) $t_i t_{i+1} t_i = t_{i+1} t_i t_{i+1}, \quad \text{for } i = 1, \dots, n - 2,$

as generating relations. To begin with, we assign the morphism

$$X_1 \otimes \cdots \otimes X_i \otimes X_{i+1} \otimes \cdots \otimes X_r \xrightarrow{\cong} X_1 \otimes \cdots \otimes X_{i+1} \otimes X_i \otimes \cdots \otimes X_r,$$

induced by the symmetry isomorphism $c(X_i, X_{i+1}) : X_i \otimes X_{i+1} \xrightarrow{\cong} X_{i+1} \otimes X_i$, to the transposition $t_i = (i \ i + 1)$. The axioms of symmetric monoidal categories imply that these morphisms satisfy the relations (a-c) attached to the elementary transpositions in Σ_r . Hence, we can use the presentation of Σ_r to coherently extend the action of the transpositions $t_i \in \Sigma_r$ on tensor powers to the whole symmetric group.

0.11. *Tensor products over arbitrary finite sets.* In our constructions, we often deal with tensor products $\bigotimes_{i_k \in \underline{r}} X_{i_k}$, running over an arbitrary set $\underline{r} = \{i_1, \dots, i_r\}$ (not necessarily equipped with a canonical ordering). In fact, we effectively realize such a tensor product $\bigotimes_{i_k \in \underline{r}} X_{i_k}$ as an ordered tensor product $X_{u(1)} \otimes \cdots \otimes X_{u(r)}$, which we associate to the choice of a bijection $u : \{1, \dots, r\} \xrightarrow{\cong} \underline{r}$. The tensor products associated to different bijection choices $u, v : \{1, \dots, r\} \xrightarrow{\cong} \underline{r}$ differ by a canonical isomorphism $s^* : X_{u(1)} \otimes \cdots \otimes X_{u(r)} \xrightarrow{\cong} X_{v(1)} \otimes \cdots \otimes X_{v(r)}$ which we determine from the permutation $s \in \Sigma_r$ such that $v = u \cdot s$, by using the just defined action of symmetric groups on tensors.

In principle, the tensor product $\bigotimes_{i_k \in \underline{r}} X_{i_k}$ is only defined up to these canonical isomorphisms. However, we can adapt the general Kan extension process to make this construction more rigid, at least, when we work in a symmetric monoidal category \mathcal{M} equipped with fixed colimit functors. Formally, we define the unordered tensor product as the colimit $\bigotimes_{i_k \in \underline{r}} X_{i_k} = \text{colim}_{u: \{1, \dots, r\} \xrightarrow{\cong} \underline{r}} X_{u(1)} \otimes \cdots \otimes X_{u(r)}$ running over the category formed by the bijections $u : \{1, \dots, r\} \xrightarrow{\cong} \underline{r}$ as objects,

and the permutations $s \in \Sigma_r$ such that $v = u \cdot s$ as morphisms. The colimit process automatically performs the identification of the tensors associated to different bijection choices.

This construction can be regarded as an instance of a Kan extension process which we will apply to structures, called symmetric sequences, underlying operads (see §I.3.5).

0.12. *Enriched category structures of base categories.* The morphism sets of a category \mathcal{C} will always be denoted by $\text{Mor}_{\mathcal{C}}(X, Y)$. But many categories that we consider \mathcal{C} , including the base categories themselves $\mathcal{M} = \text{Set}, \text{Top}, \text{Mod}, \dots$, come equipped with a hom-bifunctor $\text{Hom}_{\mathcal{C}}(-, -) : \mathcal{C}^{op} \times \mathcal{C} \rightarrow \mathcal{M}$, with values in one of our base symmetric monoidal categories $\mathcal{M} = \text{Set}, \text{Top}, \text{Mod}, \dots$, and which provides \mathcal{C} with an enriched category structure.

The structure of an enriched category includes operations that extend the classical composition structure attached to the morphism sets of plain categories. In the usual setting, the units of the composition are given by identity morphisms $id_X \in \text{Mor}_{\mathcal{C}}(X, X)$ associated to all objects $X \in \mathcal{C}$. In the case of an enriched category, the units of the composition are morphisms

$$(a) \quad id_X : \mathbb{1} \rightarrow \text{Hom}_{\mathcal{C}}(X, X),$$

given for all objects $X \in \mathcal{C}$, and defined on the tensor unit of the base category $\mathbb{1}$. The composition products are morphisms

$$(b) \quad \circ : \text{Hom}_{\mathcal{C}}(Y, Z) \otimes \text{Hom}_{\mathcal{C}}(X, Y) \rightarrow \text{Hom}_{\mathcal{C}}(X, Z),$$

given for all $X, Y, Z \in \mathcal{C}$, and where we consider the tensor product of hom-objects in the base category instead of the cartesian product of morphism sets. These composition products are assumed to satisfy obvious analogues, now expressed in terms of commutative diagrams, of the unit and associativity relations of the composition in plain categories. Each of our base categories $\mathcal{M} = \text{Set}, \text{Top}, \text{Mod}, \dots$ is enriched over itself. In the case of sets Set , we trivially take $\text{Hom}_{\text{Set}}(-, -) = \text{Mor}_{\text{Set}}(-, -)$. In the case of topological spaces Top , the hom-objects $\text{Hom}_{\text{Top}}(X, Y)$ are given by the morphism sets $\text{Mor}_{\text{Top}}(X, Y)$ equipped with the usual compact-open topology. In the case of modules Mod , the hom-objects $\text{Hom}_{\text{Mod}}(A, B)$ are similarly given by the morphism sets of the category $\text{Mor}_{\text{Mod}}(A, B)$, which come naturally equipped with a module structure (the usual one). In our remaining fundamental examples $\mathcal{M} = \text{Simp}, \text{dg Mod}, \dots$, the hom-objects $\text{Hom}_{\mathcal{M}}(A, B)$ consist of maps satisfying some mild requirements, extending the definition of a morphism in these categories. We give the explicit definition of these hom-objects later on, when we begin to use these categories.

In all these examples, we actually take hom-objects which fit an adjunction relation with respect to the symmetric monoidal structure (authors say that our base categories are instances of closed monoidal categories). We review this connection in a next paragraph.

0.13. *The general notion of an enriched category, morphisms and homomorphisms.* In general, an enriched category structure is given as an extra structure associated with a plain category \mathcal{C} , and we deal with both morphism sets $\text{Mor}_{\mathcal{C}}(-, -)$, from which the category \mathcal{C} is basically defined, and hom-objects $\text{Hom}_{\mathcal{C}}(-, -)$, with values in a given symmetric monoidal category \mathcal{M} (not necessarily a base category). We use an expression like category enriched over \mathcal{M} when we need to specify this category where our hom-objects are defined. We assume that the hom-objects

are equipped with unit and composition morphisms §0.12(a-b) formed within our symmetric monoidal category \mathcal{M} .

In our setting, where enriched categories arise as extra-structures associated with an underlying plain category \mathcal{C} , we also naturally assume that the hom-objects form a bifunctor $\text{Hom}_{\mathcal{C}}(-, -) : \mathcal{C}^{op} \times \mathcal{C} \rightarrow \mathcal{M}$ so that we have morphisms

$$(a) \quad f_* : \text{Hom}_{\mathcal{C}}(-, X) \rightarrow \text{Hom}_{\mathcal{C}}(-, Y) \quad \text{and} \quad f^* : \text{Hom}_{\mathcal{C}}(Y, -) \rightarrow \text{Hom}_{\mathcal{C}}(X, -),$$

associated to any $f \in \text{Mor}_{\mathcal{C}}(X, Y)$. The unit morphisms and the composition operations §0.12(a-b) have to be left invariant under these actions of morphisms on hom-objects.

In our basic examples, where hom-objects are made from point-sets, we can identify the actual morphisms of the category $f \in \text{Mor}_{\mathcal{C}}(X, Y)$ with particular elements of the hom-objects $\text{Hom}_{\mathcal{C}}(X, Y)$. The general elements $u \in \text{Hom}_{\mathcal{C}}(X, Y)$ are conversely identified with maps $u : X \rightarrow Y$ satisfying some mild requirements, generally extending the definition of a morphism of the category (as alluded to in the previous paragraph in the case of our base categories of simplicial sets, graded modules, dg-modules, ...). In this setting, we use the noun of homomorphism to refer to the general elements of the hom-objects $\text{Hom}_{\mathcal{C}}(X, Y)$ as opposed to the morphisms, which refer to the elements of the morphism sets $\text{Mor}_{\mathcal{C}}(X, Y)$. But we may use the arrow notation $u : X \rightarrow Y$ when we want to regard such a homomorphism $u \in \text{Hom}_{\mathcal{C}}(X, Y)$ as a map. In this case, the belonging category of the arrow u is specified by the context. The composition on hom-objects also usually extends the composition on morphisms, and the morphisms (a), making the hom-objects into a bifunctor, are generally identified with the left (respectively, right) composition with the homomorphism associated to $f \in \text{Mor}_{\mathcal{C}}(X, Y)$.

In a general setting, a correspondence between morphisms and homomorphisms can be formalized in terms of morphisms

$$(b) \quad \iota_{\sharp} : \mathbb{1}[\text{Mor}_{\mathcal{C}}(X, Y)] \rightarrow \text{Hom}_{\mathcal{C}}(X, Y),$$

where the expression $\mathbb{1}[\text{Mor}_{\mathcal{C}}(X, Y)]$ denotes the coproduct, running over the set of morphisms $f \in \text{Mor}_{\mathcal{C}}(X, Y)$, of copies of the unit object $\mathbb{1}$. We develop this formalism in the case of Hopf categories (categories enriched in counitary cocommutative coalgebras) in §I.9.

0.14. *Closed symmetric monoidal categories.* In the case of our base categories $\mathcal{M} = \text{Set}, \text{Top}, \text{Mod}, \dots$, we actually take hom-bifunctors that fit in an adjunction relation $\text{Mor}_{\mathcal{M}}(X \otimes Y, Z) \simeq \text{Mor}_{\mathcal{M}}(X, \text{Hom}_{\mathcal{M}}(Y, Z))$ with respect to the symmetric monoidal structure of the category. The bijection which gives this adjunction relation is also assumed to be natural in $X, Y, Z \in \mathcal{M}$.

In general, a symmetric monoidal category \mathcal{M} is said to be closed when the tensor product $\otimes : \mathcal{M} \times \mathcal{M} \rightarrow \mathcal{M}$ has a right adjoint $\text{Hom}_{\mathcal{M}}(-, -) : \mathcal{M}^{op} \times \mathcal{M} \rightarrow \mathcal{M}$ fitting in an adjunction relation of this form

$$(a) \quad \text{Mor}_{\mathcal{M}}(X \otimes Y, Z) \simeq \text{Mor}_{\mathcal{M}}(X, \text{Hom}_{\mathcal{M}}(Y, Z)),$$

for $X, Y, Z \in \mathcal{M}$. Note that the existence of this adjoint forces the colimit preservation requirement of §0.8.

The hom-objects $\text{Hom}_{\mathcal{M}}(X, Y)$ defined by an internal hom-functor naturally inherit an evaluation morphism

$$(b) \quad \text{Hom}_{\mathcal{M}}(X, Y) \otimes X \xrightarrow{\epsilon} Y,$$

representing the augmentation of the adjunction (a), and which generalizes the usual evaluation of maps in the category of sets. In addition to the evaluation morphism, we have a morphism

$$(c) \quad X \xrightarrow{\iota} \mathrm{Hom}_{\mathcal{M}}(Y, X \otimes Y)$$

giving the unit of the adjunction.

The hom-objects of a closed symmetric monoidal category automatically inherit composition units $id_X : \mathbb{1} \rightarrow \mathrm{Hom}_{\mathcal{C}}(X, X)$, given by the right adjoint of the unit isomorphisms $\mathbb{1} \otimes X \xrightarrow{\cong} X$ of the symmetric monoidal structure, as well as composition operations $\circ : \mathrm{Hom}_{\mathcal{C}}(Y, Z) \otimes \mathrm{Hom}_{\mathcal{C}}(X, Y) \rightarrow \mathrm{Hom}_{\mathcal{C}}(X, Z)$, given by the right adjoint of the composite evaluation morphisms $\mathrm{Hom}_{\mathcal{M}}(Y, Z) \otimes \mathrm{Hom}_{\mathcal{M}}(X, Y) \otimes X \xrightarrow{id \otimes \epsilon} \mathrm{Hom}_{\mathcal{M}}(Y, Z) \otimes Y \xrightarrow{\epsilon} Z$. Thus, any closed symmetric monoidal category is automatically enriched in the sense of §0.12.

Besides, we have tensor product operations $\mathrm{Hom}_{\mathcal{M}}(A, B) \otimes \mathrm{Hom}_{\mathcal{M}}(X, Y) \xrightarrow{\otimes} \mathrm{Hom}_{\mathcal{M}}(A \otimes X, B \otimes Y)$, given by the right adjoint of the composites $\mathrm{Hom}_{\mathcal{M}}(A, B) \otimes \mathrm{Hom}_{\mathcal{M}}(X, Y) \otimes A \otimes X \simeq \mathrm{Hom}_{\mathcal{M}}(A, B) \otimes A \otimes \mathrm{Hom}_{\mathcal{M}}(X, Y) \otimes X \xrightarrow{\epsilon \otimes \epsilon} B \otimes Y$, where we apply the symmetry operator of \mathcal{M} and we form the tensor product of the evaluation morphisms associated to the hom-objects. This tensor product operation gives an extension, at the level of enriched hom-objects, of the tensor product of morphisms and satisfies the same unit, associativity, and symmetry relations.

0.15. *The notation of colimits, limits and universal objects.* We adopt the following conventions for the notation of colimits, limits, and universal objects in categories. We generally use the unbased set notation \emptyset for the initial object of a ground category, the notation \amalg for coproducts, and the notation $*$ for the terminal object. We use additive category notation when we deal with additive structures, or when our ground category consists of modules. We then write 0 for the initial object of the category (the zero object). We also use \oplus as a generic notation for the coproduct in the additive case.

When we deal with a category of objects equipped with a multiplicative structure (algebras, operads, ...), we generally adopt the base set notation \vee , for the coproduct \vee , but we do not follow any general convention for the notation of the initial object in this setting. In each instance of multiplicative structure, we can actually identify the initial object of our category with a particular object of the base category, of which we therefore take the notation up. We use a similar convention for coproducts, and other universal constructions, which we can deduce from a structure operation given with our base category. We then take up the notation of the underlying operation of the base base category for our universal objects. For instance, we generally use the tensor product notation to refer to coproducts in categories of unitary commutative algebras, because we observe in §I.2.0.2 that the coproduct is realized by the tensor product in this case.

I. From Operads to Grothendieck-Teichmüller Groups

Part 0

The General Theory of Operads

CHAPTER 1

The Basic Concepts of the Theory of Operads

The purpose of this chapter is to explain the definition of an operad and some basic concepts associated with this notion.

We give the formal definition of an operad in the first section of the chapter (§1.1). We also explain the definition of an algebra over an operad in this section and we give some basic examples in sets to illustrate the fundamental concepts of the theory. We examine the application of standard constructions of category theory (like free objects, colimits, limits) to operads and to algebras over operads in the second and third sections (§1.2-§1.3). We check by the way that the usual categories of algebras (associative algebras, commutative algebras, Lie algebras) are identified with categories of algebras associated to operads. We also devote an appendix section (§1.4) to a short survey of the definition of particular colimits (reflexive coequalizers and filtered colimits), which we use in our constructions on operads.

The basic definition of an operad, given in the next section, makes sense in the general setting of a symmetric monoidal category \mathcal{M} , where we only assume the existence of a tensor product $\otimes : \mathcal{M} \times \mathcal{M} \rightarrow \mathcal{M}$ satisfying the unit, associativity and symmetry axioms of §0.8. In many applications however, we need the additional requirement that the tensor product preserves colimits on each side (see §0.8). In certain cases, we also need the existence of an internal-hom bifunctor $\text{Hom}_{\mathcal{M}}(-, -) : \mathcal{M}^{op} \times \mathcal{M} \rightarrow \mathcal{M}$ providing the base category \mathcal{M} with a closed symmetric monoidal category structure (see §§0.8-0.14). To simplify, we assume for the moment that we deal with a base category \mathcal{M} which fulfils all these assumptions. We take our examples among the category of sets $\mathcal{M} = \text{Set}$, simplicial sets $\mathcal{M} = \text{Simp}$, topological spaces $\mathcal{M} = \text{Top}$, modules over the ground ring $\mathcal{M} = \text{Mod}$, or among a variant of these categories. We will just devote a few remarks to technical issues arising from the non-preservation of colimits by the tensor product.

The preservation of colimits by the tensor product is explicitly used in §§1.2-1.3, when we examine the application of categorical constructions to operads and to algebras over operads. The preservation of colimits is also a necessary condition for the existence of an internal-hom (see §0.14). Therefore, as soon as we deal with internal hom-objects (in §§1.1.11-1.1.15) we also implicitly assume that our colimit requirement is fulfilled.

Recall that we generically use the unbased set notation \emptyset for the initial object of our base category, the notation $*$ for the terminal object, and the notation \amalg for coproducts. We just move to additive category notation when we deal with additive structures, or when the ground category consists of modules. We then write 0 for the zero object (giving the initial object of the category), and \oplus for the coproduct.

In §§1.2-1.3, we explain that the category of operads and the categories of algebras associated to an operad have all limits and colimits. The limits of operads

and algebras are created in the underlying ground category in general, as well as some particular colimits, but not coproducts (see §§1.2-1.3). Therefore, we keep the notation of the ground category for limits in the category of operads and in categories of algebras over operads, but we will adopt another style of notation (the base set notation \vee) for coproducts.

The definition of an operad recalled in this chapter is borrowed from May's monograph [134]. Besides this reference, we should cite Boardman-Vogt's work [26] for another approach of the notion of an operad, and Ginzburg-Kapranov's article [75], from which we borrow the definition free operads and the definition of operads by generators and relations. Reference books on operads, emphasizing various aspects of the theory, include [60] about modules and algebra categories associated to operads, [112] about operads and higher categories, [120] focusing on algebraic operads and the Koszul duality theory, and [131] providing an overall introduction to operads and to the Koszul duality of operads. Most definitions and statements of this introductory chapter are covered by these reference, and we do not make any claim of originality at this stage of our work.

1.1. The notion of an operad and of an algebra over an operad

The purpose of this section, as we just explained, is to introduce the definition of an operad and of an algebra over an operad. We have several approaches available. In this introductory chapter, we mostly deal with May's definitions [134], which has the advantage of giving a direct and simple interpretation of operadic structures in terms of operations acting on algebras. In §3, we explain the equivalence between May's approach and a more combinatorial definition of operads, involving an interpretation of operadic composition structures in terms of trees. To prepare this subsequent revision of the definition, we give a first introduction to the tree representation of operads in this section. We will also heavily use the formalism of trees in our study of deformation complexes of operads.

Intuitively, an operad P consists of a collection of objects $P(r)$ collecting abstract operations of r variables $p = p(x_1, \dots, x_r)$ with a variable number r running over \mathbb{N} . The notion of an operad is formally defined as a structure given by such a collection together with composition products modeling the composition of operations. From this viewpoint, an operad can be regarded as a particular instance of analyzer, a notion introduced by Lazard in [109] in order to generalize the power series operations used in the theory of formal Lie groups.

In the literature, the number of variables r in an operation $p = p(x_1, \dots, x_r)$ (not necessarily related to an operad) is sometimes referred to as the arity of p . In the operadic context, we use the term of arity to refer to the number r indexing the terms of an operad and of any related structure. For the moment, we focus on operad terms $P(r)$ indexed by non-negative integers $r \in \mathbb{N}$, but in §3.5, we consider an extension of the definition of an operad where terms $P(\underline{r})$ indexed by all finite sets $\underline{r} = \{i_1, \dots, i_r\}$ are considered. In this setting, we use the term of arity to refer to the cardinal of the set $\underline{r} = \{i_1, \dots, i_r\}$ (either regarded as a non-negative integer, or as a class of finite sets in bijection to each other).

The explicit definition of an operad, beyond the intuitive approach, is quite intricate. In fact, this definition is recursive in nature, because it implicitly relies on a primitive operad structure on permutations. In the logical order, we should

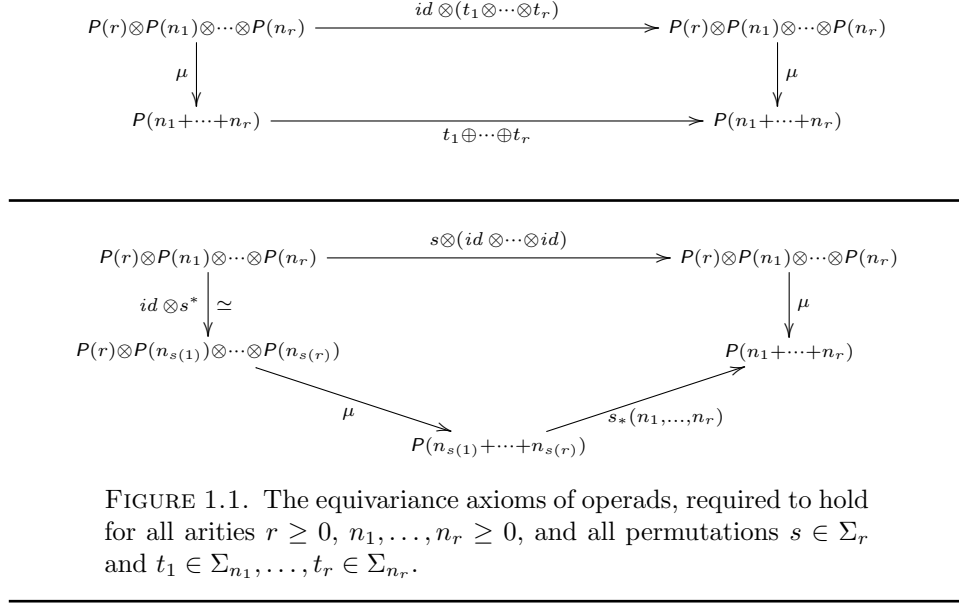

explicitly define the operations underlying the composition structure of the permutation operad first, and introduce the general definition of an operad afterwards. But, we will proceed differently in order to bring out the ideas underlying the definition. In a first stage, we only define the shape of the structure of an operad. This incomplete account is enough to fully explain the intuitive interpretation of the operad formalism, which we do next. Then we give the missing part of our definition, which amounts to the definition of the alluded-to primitive operad structure on permutation groups.

1.1.1. *The structure of an operad.* Formally, an operad in a base category \mathcal{M} consists of a sequence of objects $P(r) \in \mathcal{M}$, $r \in \mathbb{N}$, where $P(r)$ is equipped with an action of the symmetric group on r letters Σ_r , together with

- (a) a unit morphism $\eta : \mathbb{1} \rightarrow P(1)$,
- (b) and a composition structure, defined by morphisms

$$P(r) \otimes P(n_1) \otimes \cdots \otimes P(n_r) \xrightarrow{\mu} P(n_1 + \cdots + n_r),$$

for $r \geq 0$ and $n_1, \dots, n_r \geq 0$,

so that natural equivariance, unit and associativity relations, expressed by the commutativity of the diagrams of Figure 1.1, 1.2, and 1.3, hold. The definition of the permutations $t_1 \oplus \cdots \oplus t_r$ and $s_*(n_1, \dots, n_r)$, occurring in the equivariance relations of Figure 1.1, is put off until §1.1.7.

In principle, we assume that the action of the symmetric group on the components of an operad is given on the left, and our equivariance axioms are formulated accordingly. This convention is used by most authors.

The morphism η in the above definition is referred to as the unit morphism of the operad, and the morphisms μ as the composition products. In what follows, we also use the terminology of full composition product to distinguish these morphisms μ from partial composition operations which we introduce later on. In general,

$$\begin{array}{ccc}
1 \otimes P(n) & \xrightarrow{\eta \otimes id} & P(1) \otimes P(n) \\
& \searrow \simeq & \downarrow \mu \\
& & P(n)
\end{array}
\quad \Bigg| \quad
\begin{array}{ccc}
P(r) \otimes 1^{\otimes r} & \xrightarrow{id \otimes \eta^{\otimes r}} & P(r) \otimes P(1)^{\otimes r} \\
& \searrow \simeq & \downarrow \mu \\
& & P(r)
\end{array}$$

FIGURE 1.2. The unit axioms of operads, required to hold for all $r \geq 0$ and all $n \geq 0$.

$$\begin{array}{ccc}
\{P(r) \otimes P(s_1) \otimes \dots \otimes P(s_r)\} \otimes \{P(n_1^1) \otimes \dots \otimes P(n_1^{s_1})\} & \xrightarrow{\simeq} & P(r) \otimes \{P(s_1) \otimes P(n_1^1) \otimes \dots \otimes P(n_1^{s_1})\} \\
\otimes \dots & & \otimes \dots \\
\otimes \{P(n_r^1) \otimes \dots \otimes P(n_r^{s_r})\} & & \otimes \{P(s_r) \otimes P(n_r^1) \otimes \dots \otimes P(n_r^{s_r})\} \\
\downarrow \mu \otimes id \otimes \dots \otimes id & & \downarrow id \otimes \mu \otimes \dots \otimes \mu \\
P(s_1 + \dots + s_r) \otimes P(n_1^1) \otimes \dots \otimes P(n_1^{s_1}) & & P(r) \otimes P(n_1^1 + \dots + n_1^{s_1}) \\
\otimes \dots & & \otimes \dots \\
\otimes P(n_r^1) \otimes \dots \otimes P(n_r^{s_r}) & & \otimes P(n_r^1 + \dots + n_r^{s_r}) \\
\searrow \mu & & \swarrow \mu \\
P(n_1^1 + \dots + n_1^{s_1} + \dots + n_r^1 + \dots + n_r^{s_r}) & &
\end{array}$$

FIGURE 1.3. The associativity axiom of operads, required to hold for all arities $r \geq 0$, $s_1, \dots, s_r \geq 0$, and all $n_i^j \geq 0$.

we specify an operad by the notation of the underlying collection P , and we use the letters η and μ as generic notation for the corresponding unit and product morphisms. We simply add a lower-script $\eta = \eta_P$ (respectively, $\mu = \mu_P$) specifying the operad to which this unit (respectively, product) morphism is attached when necessary.

1.1.2. *The category of operads.* We naturally define an operad morphism $\phi : P \rightarrow Q$ as a sequence of morphisms in the base category $\phi : P(r) \rightarrow Q(r)$, $r \in \mathbb{N}$, commuting with the action of symmetric groups and preserving the unit and the composition structure of the operads. When we work within a fixed base category \mathcal{M} , we use the notation $\mathcal{O}p$ to refer to the category formed by operads in \mathcal{M} and this natural class of morphisms. When we need to specify the base category in which our operads are defined, we simply add this category as a prefix to our notation, and we write $\mathcal{O}p = \text{Base}\mathcal{O}p$. To give an example, we may use the notation $\mathcal{J}op\mathcal{O}p$ to refer to the category of topological operads (corresponding to the case of operads in topological spaces).

In §3.2, we introduce a variant of the category operads, where the symmetric group action is replaced by another internal structures, encoded by an action of a certain category Λ . Our general convention is to add the notation of this category Λ as a prefix to the expression $\mathcal{O}p$ in order to get the notation of this variant of the category of operads. Under this convention, we may use the expression $\Sigma\mathcal{O}p$ (rather than $\mathcal{O}p$) to refer to the operad category of §1.1.1, because we adopt the notation Σ for the category, formed by the disjoint union of the symmetric groups, which models the internal symmetric structure of these operads.

$$\begin{array}{ccc}
 P(r) \otimes P(n_1) \otimes \cdots \otimes P(n_r) & \xrightarrow{s \otimes (t_1 \otimes \cdots \otimes t_r)} & P(r) \otimes P(n_1) \otimes \cdots \otimes P(n_r) \\
 \downarrow \text{id} \otimes s^* \simeq & & \downarrow \mu \\
 P(r) \otimes P(n_{s(1)}) \otimes \cdots \otimes P(n_{s(r)}) & & P(n_1 + \cdots + n_r) \\
 \searrow \mu & \nearrow s(t_1, \dots, t_r) & \\
 & P(n_{s(1)} + \cdots + n_{s(r)}) &
 \end{array}$$

FIGURE 1.4. The equivariance axioms of operads, put in a single diagram, where $s(t_1, \dots, t_r) \in \Sigma_{n_1 + \cdots + n_r}$ is actually an operadic composite of the given permutations $s \in \Sigma_r$ and $t_1 \in \Sigma_{n_1}, \dots, t_r \in \Sigma_{n_r}$.

The category of non-symmetric operads, considered in the literature, is another variant of the category of operads defined by forgetting about the action of symmetric groups and the equivariance axioms in §1.1.1. The expression of symmetric operads, referring to the symmetric group actions, is used by some authors to specify the operad structures which we precisely define §1.1.1. But we do not use non-symmetric operads in this book. The category of symmetric operads is our category of plain operads, and therefore, the adoption of the short notation \mathcal{Op} for that category $\mathcal{Op} = \Sigma \mathcal{Op}$ is natural for us too.

We may also consider variants of the category of operads where we drop the term of arity zero from the definition. We use the expression of non-unitary operad to refer to this category of operads. When the tensor product preserves colimits, we can identify a non-unitary operad with an operad, in the sense of the definition §1.1.1, where the arity zero term is the initial object of the base category. We then regard the category of non-unitary operads as a subcategory of our category of operads §1.1.1. We heavily use the concept of non-unitary operad, and we shall devote subsequent paragraphs of this section to this notion.

1.1.3. *Miscellaneous remarks on the definition of an operad.* We may note that, in the case $r = 0$, the composition product of §1.1.1(b) involves an empty set of factors $P(n_i)$. This product therefore reduces to an endomorphism of $P(0)$. The (right) unit axiom of Figure 1.2 actually forces this endomorphism to be the identity of $P(0)$. Thus, the consideration of a composition product for $r = 0$ in §1.1.1 does not add anything to the structure of an operad. Nevertheless, the formulation of the associativity axiom in full generality in Figure 1.3, requires to integrate this degenerate case in our definition.

The equivariance axioms of Figure 1.1 can also be put together in a single equivalent commutative diagram, displayed in Figure 1.4. The permutation $s(t_1, \dots, t_r)$ occurring in this diagram is given by the composite $s(t_1, \dots, t_r) = t_1 \oplus \cdots \oplus t_r \cdot s_*(n_1, \dots, n_r)$ of the permutations $t_1 \oplus \cdots \oplus t_r$ and $s_*(n_1, \dots, n_r)$, occurring in our initial equivariance axioms. Soon (in Proposition 1.1.9), we identify this composite permutation $s(t_1, \dots, t_r)$ as the outcome of an operadic composition product on permutations.

Intuitively, the object $P(r)$ in the definition of an operad collects abstract operations $p = p(x_1, \dots, x_r)$ in a given arity $r \in \mathbb{N}$ (as we explain in the introduction

of this section). The composition structure of §1.1.1(a-b) reflects a natural composition structure attached to operations of this form, and the definition of our operations $t_1 \oplus \cdots \oplus t_r$ and $s_*(n_1, \dots, n_r)$ on permutations reflects this interpretation of the composition structure. Thus, we explain this interpretation first, from the shape of our axioms, and we explicitly define the permutations $t_1 \oplus \cdots \oplus t_r$ and $s_*(n_1, \dots, n_r)$ afterwards.

1.1.4. *The interpretation of an operad structure.* In a point set context, we may use the notation $p(q_1, \dots, q_r) \in P(n_1, \dots, n_r)$ for the image of a tensor $p \otimes (q_1 \otimes \cdots \otimes q_r) \in P(r) \otimes P(n_1) \otimes \cdots \otimes P(n_r)$ under the composition product §1.1.1(b). The unit morphism of §1.1.1(a) is also equivalent to the definition of a distinguished element $1 \in P(1)$, referred to as the unit of the operad. In many constructions, we consider partial composition operations $\circ_i : P(m) \otimes P(n) \rightarrow P(m+n-1)$ determined from the composition product by the formula $p \circ_i q = p(1, \dots, 1, q, 1, \dots, 1)$ where the operation $q \in P(n)$ is plugged in the i th input of $p \in P(m)$. Operad units are assigned to the remaining inputs of p .

In the intuitive interpretation of elements $p \in P(r)$ in terms of abstract operations $p = p(x_1, \dots, x_r)$, the action of permutations $s \in \Sigma_r$ on $P(r)$ models a permutation of inputs

$$sp = p(x_{s(1)}, \dots, x_{s(r)}),$$

and the operadic composition process models the definition of composite operations of the form

$$\begin{aligned} p(q_1, \dots, q_r) &= p(q_1(x_{k_1+1}, \dots, x_{k_1+n_1}), \\ &\quad q_2(x_{k_2+1}, \dots, x_{k_2+n_2}), \\ &\quad \vdots \\ &\quad q_r(x_{k_r+1}, \dots, x_{k_r+n_r})), \end{aligned}$$

where we set $k_i = n_1 + \cdots + n_{i-1}$. (We have by convention $k_1 = 0$ when $i = 1$.) Thus, in the expression of the composite $p(q_1, \dots, q_r)$, the variables are split into groupings attached to each plugged operation q_i . Similarly, the operadic unit represents an identity operation (of one variable) $1 = id(x_1)$ and a partial composite $p \circ_i q = p(1, \dots, 1, q, 1, \dots, 1)$ can be identified with a composite operation of the form

$$p \circ_i q = p(x_1, \dots, x_{i-1}, q(x_i, \dots, x_{i+n-1}), x_{i+n}, \dots, x_{m+n-1}).$$

In these point set representations, the unit axioms read $1(p) = p$, $p(1, \dots, 1) = p$, and the associativity axiom reads

$$p(q_1, \dots, q_r)(\theta_1^1, \dots, \theta_1^{s_1}, \dots, \theta_r^1, \dots, \theta_r^{s_r}) = p(q_1(\theta_1^1, \dots, \theta_1^{s_1}), \dots, q_r(\theta_r^1, \dots, \theta_r^{s_r})),$$

where we assume $p \in P(r)$, $q_1 \in P(s_1), \dots, q_r \in P(s_r)$ and $\theta_i^j \in P(n_i^j)$. The equivariance axioms come from the identities

$$\begin{aligned} &p(t_1 q_1, \dots, t_r q_r) \\ &= p(q_1(x_{k_1+t_1(1)}, \dots, x_{k_1+t_1(n_1)}), \dots, q_r(x_{k_r+t_r(1)}, \dots, x_{k_r+t_r(n_r)})), \\ &sp(q_1, \dots, q_r) \\ &= p(q_{s(1)}(x_{k_{s(1)}+1}, \dots, x_{k_{s(1)}+n_{s(1)}}), \dots, q_{s(r)}(x_{k_{s(r)}+1}, \dots, x_{k_{s(r)}+n_{s(r)}})). \end{aligned}$$

The permutations $t_1 \oplus \cdots \oplus t_r$ and $s_*(n_1, \dots, n_r)$, which we formally define in §1.1.7, correspond to the input permutations occurring in these formulas.

Note that the composition product can be written in terms of partial composites. Indeed, the unit and associativity axioms imply that the composition product satisfies $p(q_1, \dots, q_r) = (\dots (p \circ_{k_1+1} q_1) \circ_{k_2+1} \dots) \circ_{k_r+1} q_r$, for any $p \in P(r)$ and all $q_1 \in P(n_1), \dots, q_r \in P(n_r)$, where we set $k_i = n_1 + \dots + n_{i-1}$ for $i = 1, \dots, r$. This observation is fully developed in §3.1, where we give another definition, in terms of the partial composition operations, of the composition structure of an operad.

1.1.5. *The graphical representation of operad elements.* To gain intuition, we may also use a box picture

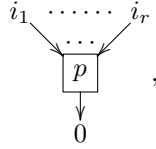

to represent operations of the form collected by an operad $p \in P(r)$. The ingoing edges of the box represent the inputs of the operation and the outgoing edge is used to symbolize the output.

In this picture, the composition products of an operad model composition patterns of the following form

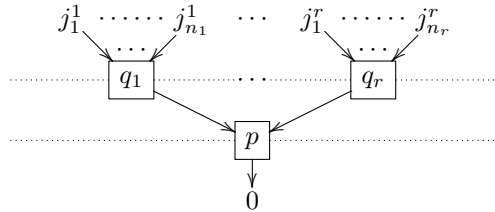

where we plug the outputs of the upper level operations $q_1 \in P(n_1), \dots, q_r \in P(n_r)$ in the inputs of the lower level operation $p \in P(r)$ to obtain a composite operation $p(q_1, \dots, q_r) \in P(n_1 + \dots + n_r)$ with as much inputs as the upper level operations together and one final output. In the sequel, we use the above picture to represent the tensor $p \otimes (q_1 \otimes \dots \otimes q_r) \in P(r) \otimes P(n_1) \otimes \dots \otimes P(n_r)$, to which the operadic composition product is applied, instead of the outcome of the process.

For the moment, as long as we assume that operad terms are indexed by finite ordinals $\underline{r} = \{1 < \dots < r\}$, we can assume that the ingoing edges of a box in such a figure are arranged in the plane according to the input ordering of the corresponding operation $p \in P(r)$. However, we can make a convenient use of indices attached to ingoing edges of boxes in our figures. Namely, we can use the indices of ingoing edges to mark operations on the inputs of operations. For this purpose, we take the convention that edges represent a bijection, not necessarily the identity one, between an indexing set and the input set of an operation. In the picture of composite operations for instance, we associate the indices $j_k^i = n_1 + \dots + n_{i-1} + k$, $k = 1, \dots, n_i$, corresponding to the input indexing of the composite operation $p(q_1, \dots, q_r)$, with the ingoing edges of the box q_i , $i = 1, \dots, r$.

To identify equivalent indexings, we simply apply the relation

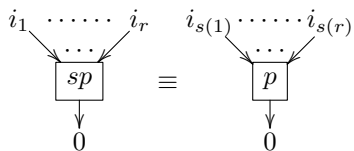

when we apply a permutation $s \in \Sigma_r$ to the inner operation $p \in P(r)$. This formalism is fully explained in §3.5, where we consider operad components associated to all finite sets.

1.1.6. *The graphical representation of an operad structure.* The representation of the previous paragraphs can be applied to operad components (instead of elements), and under our conventions, the composition products of an operad can be depicted as morphisms

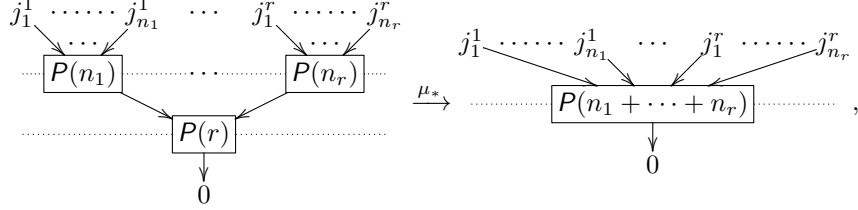

where the tree-wise arrangement of operad components formally represents the tensor product of these objects.

The unit and associativity relations of operads correspond in the tree-wise representation to the composition schemes of Figure 1.5-1.6. In these representations, we identify the application of operadic units and operadic composition products with internal operations on factors forming our tree-wise tensor product. In general, we use the notation η_* and μ_* , symbolizing the performance of internal operations on tree-wise tensors, for these mappings. The factors to which we apply the operation can in principle be determined from the internal structure of the source and target tree of our mapping.

1.1.7. *Fundamental operations on permutations.* We now define the permutations $t_1 \oplus \cdots \oplus t_r$ and $s_*(n_1, \dots, n_r)$ occurring in the equivariance relations of Figure 1.1. We use the notation $k_i = n_1 + \cdots + n_{i-1}$ introduced in the previous paragraphs. To make our definition more explicit, we use that a permutation of $(1, \dots, r)$ is equivalent to an ordered sequence $w = (w(1), \dots, w(n))$ in which each value $k = 1, \dots, r$ occurs once and only once. In some cases, we can also use the standard table representation

$$w = \begin{pmatrix} 1 & \cdots & n \\ w(1) & \cdots & w(n) \end{pmatrix}.$$

The direct sum of permutations $t_1 \in \Sigma_{n_1}, \dots, t_r \in \Sigma_{n_r}$ is the permutation of $\{1, \dots, n_1 + \cdots + n_r\}$ given by the action of t_i on the interval $\{k_i + 1, \dots, k_i + n_i\} \subset \{1, \dots, n_1 + \cdots + n_r\}$ through the canonical bijection of ordered sets $\{1 < \cdots < n_i\} \xrightarrow{\cong} \{k_i + 1 < \cdots < k_i + n_i\}$. This permutation is represented by the sequence

$$t_1 \oplus \cdots \oplus t_r = (k_1 + t_1(1), \dots, k_1 + t_1(n_1), \dots, k_r + t_r(1), \dots, k_r + t_r(n_r))$$

formed by the concatenation of the sequences $t_i = (t_i(1), \dots, t_i(n_i))$ associated to the permutations t_i , $i = 1, \dots, r$, together with the index shifts k_i . For instance, in the case of a pair of permutations $s \in \Sigma_m$ and $t \in \Sigma_n$, we obtain the identity:

$$\underbrace{(s(1), \dots, s(m))}_s \oplus \underbrace{(t(1), \dots, t(n))}_t = \begin{pmatrix} 1 & \cdots & m & m+1 & \cdots & m+n \\ s(1) & \cdots & s(m) & m+t(1) & \cdots & m+t(n) \end{pmatrix}.$$

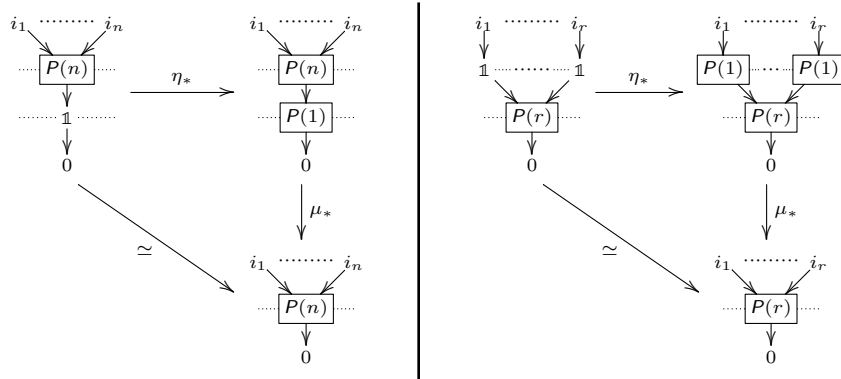

FIGURE 1.5. The tree-wise representation of the unit relations of operads

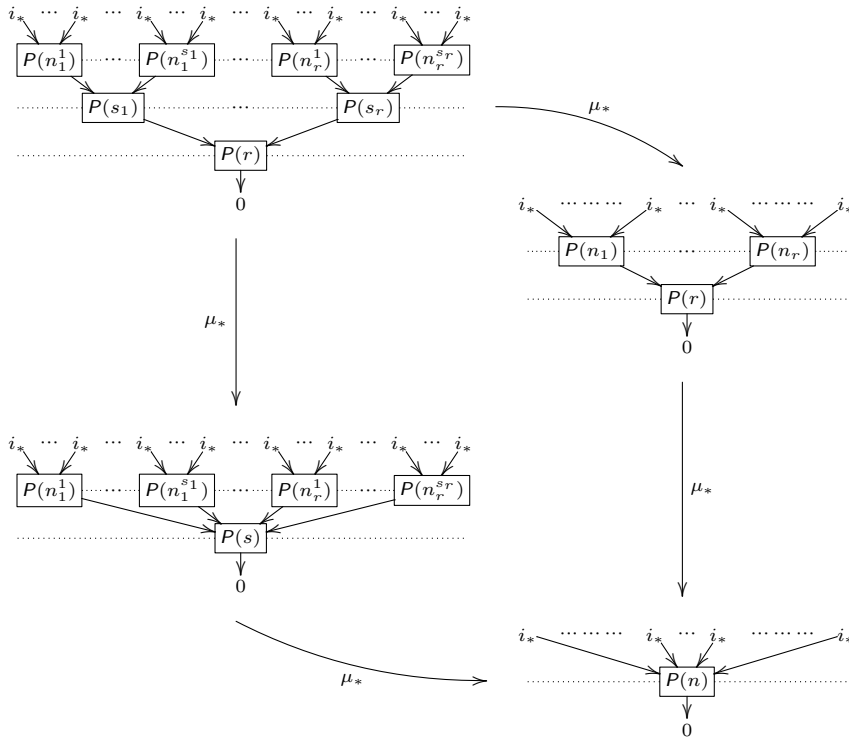

FIGURE 1.6. The tree-wise representation of the associativity relations of operads, where, to shorten notation, we set $n_i = n_i^1 + \dots + n_i^{s_i}$ for $i = 1, \dots, r$, and $s = s_1 + \dots + s_r$, $n = n_1 + \dots + n_r$.

The block permutation $s_*(n_1, \dots, n_r)$ associated to a permutation $s \in \Sigma_r$, where $n_1, \dots, n_r \geq 0$ is any collection of natural numbers, is given by the permutation, under s , of the intervals

$$\underline{n}_i = (k_i + 1, k_i + 2, \dots, k_i + n_i)$$

in the ambient set $\{1, \dots, n_1 + \dots + n_r\}$. In the sequence representation, the block permutation $s_*(n_1, \dots, n_r)$ is defined by the sequence

$$s_*(n_1, \dots, n_r) = (\underline{n}_{s(1)}, \dots, \underline{n}_{s(r)})$$

formed by the concatenation of the blocks \underline{n}_i ordered according to the permutation s . For instance, the block permutation $t_*(m, n)$ associated to a transposition $t = (1\ 2) \in \Sigma_2$ has the form:

$$\underbrace{(m+1, \dots, m+n, 1, \dots, m)}_{t_*(m,n)} = \begin{pmatrix} 1 & \cdots & n & n+1 & \cdots & n+m \\ m+1 & \cdots & m+n & 1 & \cdots & m \end{pmatrix}.$$

The following proposition follows from easy verifications:

PROPOSITION 1.1.8. *Let $n_1, \dots, n_r \geq 0$. In the symmetric group $\Sigma_{n_1 + \dots + n_r}$, we have the relation*

$$s_1 \oplus \cdots \oplus s_r \cdot t_1 \oplus \cdots \oplus t_r = (s_1 t_1) \oplus \cdots \oplus (s_r t_r)$$

for all r -tuples of permutations $(s_1, \dots, s_r), (t_1, \dots, t_r) \in \Sigma_{n_1} \times \cdots \times \Sigma_{n_r}$, the relation

$$s_*(n_1, \dots, n_r) \cdot t_*(n_{s(1)}, \dots, n_{s(r)}) = (st)_*(n_1, \dots, n_r).$$

for every $s, t \in \Sigma_r$, and the relation

$$t_1 \oplus \cdots \oplus t_r \cdot s_*(n_1, \dots, n_r) = s_*(n_1, \dots, n_r) \cdot t_{s(1)} \oplus \cdots \oplus t_{s(r)}$$

for every $s \in \Sigma_r$ and all $(t_1, \dots, t_r) \in \Sigma_{n_1} \times \cdots \times \Sigma_{n_r}$. \square

Then we obtain:

PROPOSITION 1.1.9. *The collection of symmetric groups Σ_n , $n \in \mathbb{N}$, forms an operad in sets so that:*

- (a) *the action of the symmetric group on each Σ_n is given by left translations;*
- (b) *and the composition product $\mu : \Sigma_r \times (\Sigma_{n_1} \times \cdots \times \Sigma_{n_r}) \rightarrow \Sigma_{n_1 + \dots + n_r}$ maps a collection $s \in \Sigma_r$, $(t_1, \dots, t_r) \in \Sigma_{n_1} \times \cdots \times \Sigma_{n_r}$, to the product permutation $s(t_1, \dots, t_r) = t_1 \oplus \cdots \oplus t_r \cdot s_*(n_1, \dots, n_r)$.*

PROOF. Easy verification from the relations of Proposition 1.1.8. \square

This proposition explains our remark that the operations $t_1 \oplus \cdots \oplus t_r$ and $s_*(n_1, \dots, n_r)$, which occur in the general definition of an operad, come themselves from a primitive operadic composition on the collection of symmetric groups. The definition of the composite $s(t_1, \dots, t_r)$ in Proposition 1.1.9 is forced by the equivariance axioms of operads and the requirement $id_r(id_{n_1}, \dots, id_{n_r}) = id_{n_1 + \dots + n_r}$, where we use the notation id_n for the identity permutation of the set $\{1, \dots, n\}$ (see §0.10). In this sense, the result of Proposition 1.1.9 expresses the internal coherence of the definition of an operad.

To give another (more) simple example, we can readily see that:

PROPOSITION 1.1.10. *The collection of one-point sets $pt(r) = pt$ form an operad in sets. The symmetric group action is trivial in each arity, and we take identities of one-point sets to define the composition unit and the composition products of the operad.* \square

In §2, we define a generalization of this one-point set operad in the context of symmetric monoidal categories.

Soon (see §§1.1.16-1.1.18), we explain that the permutation operad, as defined in Proposition 1.1.9, is identified with the operad of associative monoids, and the one-point set operad is identified with the operad of commutative monoids. But before studying operads associated to basic algebraic structures, we explain the definition of universal operads \mathbf{End}_A associated to the objects A of the base category \mathcal{M} .

1.1.11. *Endomorphism operads.* The operad \mathbf{End}_A associated to an object $A \in \mathcal{M}$ is called the endomorphism operad of A . The definition of this endomorphism operad involves the internal hom-bifunctor of the base category $\mathbf{Hom}_{\mathcal{M}}(-, -) : \mathcal{M}^{op} \times \mathcal{M} \rightarrow \mathcal{M}$. For short, we may also use the notation $\mathbf{Hom}(-, -) = \mathbf{Hom}_{\mathcal{M}}(-, -)$ for this hom-bifunctor.

Basically, the endomorphism operad of $A \in \mathcal{M}$ is defined by the collection of hom-objects

$$\mathbf{End}_A(r) = \mathbf{Hom}(A^{\otimes r}, A),$$

where we form the tensor powers of A in the base category \mathcal{M} . By functoriality, the hom-objects $\mathbf{End}_A(r) = \mathbf{Hom}(A^{\otimes r}, A)$ inherit an action of symmetric groups from the tensor powers $A^{\otimes r}$ and this gives the symmetric structure of the endomorphism operad.

By adjunction, the composite evaluation morphisms

$$\begin{aligned} \mathbf{Hom}(A^{\otimes r}, A) \otimes \left(\bigotimes_{i=1}^r \mathbf{Hom}(A^{\otimes n_i}, A) \right) \otimes A^{\otimes n} \\ \xrightarrow{\cong} \mathbf{Hom}(A^{\otimes r}, A) \otimes \left(\bigotimes_{i=1}^r \mathbf{Hom}(A^{\otimes n_i}, A) \otimes A^{\otimes n_i} \right) \\ \xrightarrow{\epsilon} \mathbf{Hom}(A^{\otimes r}, A) \otimes A^{\otimes r} \xrightarrow{\epsilon} A \end{aligned}$$

yield operadic composition operations

$$\mathbf{Hom}(A^{\otimes r}, A) \otimes \left(\bigotimes_{i=1}^r \mathbf{Hom}(A^{\otimes n_i}, A) \right) \xrightarrow{\mu} \mathbf{Hom}(A^{\otimes n}, A),$$

for all $r \geq 0$, $n_1, \dots, n_r \geq 0$, and where we write $n = n_1 + \dots + n_r$. These operations define the composition structure of the endomorphism operad. By adjunction too, the symmetric monoidal unit $\mathbb{1} \otimes A \simeq A$ gives a morphism

$$\mathbb{1} \xrightarrow{\eta} \mathbf{Hom}(A, A)$$

providing the collection \mathbf{End}_A with an operadic unit.

The reader can easily check that the axioms of §1.1.1 are fully satisfied in \mathbf{End}_A , and hence we have a well defined operad structure on \mathbf{End}_A .

1.1.12. *Endomorphism operads in basic ground categories.* In the basic example of sets $\mathcal{M} = \mathit{Set}$, the endomorphism operad of an object $X \in \mathit{Set}$ consists of the map sets $\mathbf{End}_X(r) = \{f : X^{\times r} \rightarrow X\}$, we have the pointwise formula

$$sf(x_1, \dots, x_n) = f(x_{s(1)}, \dots, x_{s(n)})$$

for the action of permutations, where the variables x_k now refer to actual elements of X , and the pointwise formula

$$\begin{aligned} f(g_1, \dots, g_r)(x_1, \dots, x_{n_1+\dots+n_r}) &= f(g_1(x_{k_1+1}, \dots, x_{k_1+n_1}), \\ &\quad g_2(x_{k_2+1}, \dots, x_{k_2+n_2}), \\ &\quad \vdots \\ &\quad g_r(x_{k_r+1}, \dots, x_{k_r+n_r})) \end{aligned}$$

for the composition (where we still set $k_i = n_1 + \dots + n_{i-1}$). The operadic unit is the identity of X .

In the context of topological spaces $\mathcal{M} = \mathit{Top}$, we have the same identification of the endomorphism operad \mathbf{End}_X since the map sets $\mathbf{End}_X(r) = \{f : X^{\times r} \rightarrow X\}$ are also equipped with a topology which identify them with the internal hom-objects of the category of spaces Top .

In the module context $\mathcal{M} = \mathit{Mod}$, the terms of the endomorphism operad \mathbf{End}_K , $K \in \mathit{Mod}$, consist of morphisms $f : K^{\otimes r} \rightarrow K$ by construction of hom-objects in Mod . Such morphisms $f : K^{\otimes r} \rightarrow K$ are equivalent to r -linear maps $f : (x_1, \dots, x_r) \mapsto f(x_1, \dots, x_r)$, and the action of permutations and operadic composition structures on such maps are given by the same pointwise formulas as in the context of sets.

1.1.13. *The structure of an algebra over an operad.* An algebra over an operad \mathcal{P} (a \mathcal{P} -algebra for short) is an object of the ground category $A \in \mathcal{M}$ together with morphisms

$$(a) \quad \mathcal{P}(r) \otimes A^{\otimes r} \xrightarrow{\lambda} A,$$

given for all $r \geq 0$, and such that equivariance, associativity and unit relations, formalized by the commutative diagrams of Figure 1.7-1.9, hold. In applications of this definition, we usually say that the morphisms (a) define the action of the operad \mathcal{P} on the object $A \in \mathcal{M}$. We also say that these morphisms (a) are the evaluation morphisms attached to the \mathcal{P} -algebra A when we consider an object A equipped with a fixed \mathcal{P} -action.

In general, we refer to a \mathcal{P} -algebra by the expression of the underlying object A and we use the letter λ as a generic notation for the morphisms (a) defining the action of the operad on A . As in the operad case (see §1.1.1), we simply add the expression of the algebra as a lower-script to this notation $\lambda = \lambda_A$ when we need to specify it.

The \mathcal{P} -algebras form a category with, as morphisms, the morphisms of the ground category $f : A \rightarrow B$ which preserve the \mathcal{P} -actions on A and B . In what follows, we usually convert the notation of the operad \mathcal{P} into calligraphic letters \mathcal{P} in order to get the notation of the category of algebras associated to \mathcal{P} . If necessary, then we write $\mathcal{P} = \mathcal{M}\mathcal{P}$ to specify the base category \mathcal{M} .

$$\begin{array}{ccc}
 P(r) \otimes A^{\otimes r} & \xrightarrow{s \otimes id} & P(r) \otimes A^{\otimes r} \\
 id \otimes s^* \downarrow \simeq & & \downarrow \lambda \\
 P(r) \otimes A^{\otimes r} & \xrightarrow{\lambda} & A
 \end{array}$$

FIGURE 1.7. The equivariance axiom for operad actions, required to hold for all $r \geq 0$, and all permutations $s \in \Sigma_r$.

$$\begin{array}{ccc}
 1 \otimes A & \xrightarrow{\eta \otimes id} & P(1) \otimes A \\
 & \searrow \simeq & \downarrow \lambda \\
 & & A
 \end{array}$$

FIGURE 1.8. The unit axiom for operad actions.

$$\begin{array}{ccc}
 \{P(r) \otimes P(n_1) \otimes \dots \otimes P(n_r)\} \otimes A^{\otimes n} & \xrightarrow{\simeq} & P(r) \otimes \{P(n_1) \otimes A^{\otimes n_1}\} \otimes \dots \otimes \{P(n_r) \otimes A^{\otimes n_r}\} \\
 \mu \otimes id^{\otimes n} \downarrow & & \downarrow id \otimes \lambda \otimes \dots \otimes \lambda \\
 P(n_1 + \dots + n_r) \otimes A^{\otimes n} & & P(r) \otimes A^{\otimes r} \\
 & \searrow \lambda & \swarrow \lambda \\
 & & A
 \end{array}$$

FIGURE 1.9. The associativity axiom for operad actions, required to hold for all $r \geq 0$, $n_1, \dots, n_r \geq 0$, and where we set $n = n_1 + \dots + n_r$.

1.1.14. *The interpretation of the structure of an algebra over an operad in the point set context.* In the point set context, we use the notation $p(a_1, \dots, a_r) \in A$ for the image of a tensor $p \otimes (a_1 \otimes \dots \otimes a_r) \in P(r) \otimes A^{\otimes r}$ under the evaluation morphism §1.1.13(a). In the interpretation of operads given in §1.1.4, this evaluation morphism §1.1.13(a) amounts to the evaluation of abstract operations $p = p(x_1, \dots, x_r)$ on actual elements $a_1, \dots, a_r \in A$.

In the point-set representation, the unit axiom reads $1(a) = a$ for $a \in A$, the associativity axiom reads

$$p(q_1, \dots, q_r)(a_1^1, \dots, a_1^{n_1}, \dots, a_r^1, \dots, a_r^{n_r}) = p(q_1(a_1^1, \dots, a_1^{s_1}), \dots, q_r(a_r^1, \dots, a_r^{s_r}))$$

for $p \in P(r)$, $q_1 \in P(n_1), \dots, q_r \in P(n_r)$ and $a_i^j \in A$, and the equivariance axiom reads

$$sp(a_1, \dots, a_r) = p(a_{s(1)}, \dots, a_{s(r)})$$

for $p \in P(r)$ and $a_1, \dots, a_r \in A$.

The graphical representation of §1.1.5 can also be applied to depict the action of operads on algebras. In short, we mark the ingoing edges of our black-boxes with algebra elements $a_1, \dots, a_r \in A$, which we take as inputs for the operation represented by the black-box, and we mark the outgoing edge with the result of the

operation $b = p(a_1, \dots, a_r)$. Thus, we get the following picture:

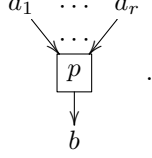

In the context of a closed monoidal category, the morphisms §1.1.13(a), defining the action of an operad P on an object $A \in \mathcal{M}$ are, by adjunction, equivalent to morphisms

$$\phi : P(r) \rightarrow \text{Hom}_{\mathcal{M}}(A^{\otimes r}, A)$$

defined for all $r \geq 0$. The equivariance, unit and associativity axioms of operad actions in §1.1.13 are actually equivalent to the observation that these morphisms define an operad morphism from P towards the endomorphism operad associated to A . Hence, we obtain the following result:

PROPOSITION 1.1.15. *The action of an operad P on an object $A \in \mathcal{M}$ is equivalent to an operad morphism $\phi : P \rightarrow \text{End}_A$, where End_A is the endomorphism operad of A . \square*

The evaluation morphisms $\epsilon : \text{Hom}_{\mathcal{M}}(A^{\otimes r}, A) \otimes A^{\otimes r} \rightarrow A$ actually give an action of the endomorphism operad End_A on A . In the equivalence of Proposition 1.1.15, this action corresponds to the identity morphism of End_A . The assertion of the proposition can be interpreted as the claim that the endomorphism operad End_A represents the universal operad acting on A in \mathcal{M} .

In a point-set context, the morphism $\phi : P \rightarrow \text{End}_A$ associates a map $p : A^{\otimes r} \rightarrow A$ to any operation $p \in P(r)$. In the formalism of §1.1.14, we are simply considering the map $p : (a_1, \dots, a_r) \mapsto p(a_1, \dots, a_r)$ associated to a fixed element $p \in P(r)$. The mapping ϕ is usually omitted in the notation of that map since the expression $p : A^{\otimes r} \rightarrow A$ already specifies that we consider a map associated to $p \in P(r)$ and not the abstract operation itself $p = p(x_1, \dots, x_r)$.

1.1.16. Examples of operads associated to basic algebraic structures in sets. In §1.2, we prove that many usual algebraic structures, including associative algebras and commutative algebras, are governed by operads. Our constructions work in any base category, including sets and \mathbb{k} -modules as most basic examples. The associative operad, the one which we associate to associative algebras, will be denoted by \mathbf{As} . The commutative operad, the one which we associate to (associative and) commutative algebras, will be denoted by \mathbf{Com} . In general, we do not assume that an algebra is equipped with a unit (unless we explicitly assert the contrary), and we accordingly use this notation \mathbf{As} (respectively \mathbf{Com}) for the version of the associative (respectively, commutative) operad governing the category associative (respectively, commutative) algebras without unit. To refer to the operads governing algebras with unit, we add a lower-script $+$ to the notation and we say that we deal with a unitary version of the operad. The connection between the operads governing the unitary and the non-unitary version of a structure is outlined in §§1.1.19-1.1.20, as a preparation for a more detailed study, which we address in §3.2. Simply mention for the moment that the operads \mathbf{As} and \mathbf{As}_+ agree in arity $r > 0$, but differ in arity $r = 0$, where we have $\mathbf{As}(0) = \emptyset$ (the initial object of the base category) in the non-unitary case, and $\mathbf{As}_+(0) = \mathbb{1}$ (the tensor unit) in the unitary case. In the case of the commutative operad, we obtain the same relation.

We soon give a general and conceptual definition, by generators and relations, of such operads (see §1.2.6, §1.2.8). Nevertheless, we prefer to give a first direct construction of the operad associated to associative (respectively, commutative) algebras in order to complete this introductory account with simple examples. For the moment, we focus on the set-theoretical context, and then we rather use the terminology of associative (respectively, commutative) monoid for the associative (respectively, commutative) algebras. The case of \mathbb{k} -modules, which provides our second basic examples of symmetric monoidal categories (after the category of sets) will be addressed in the next sections.

Previously, we have observed that the collection of symmetric groups Σ_r , $r \in \mathbb{N}$, forms an operad in sets, as well as the collection of one-point sets $pt(r) = pt$. In the next propositions, we precisely prove that the permutation operad has the associative monoids as associated algebras, and the one-point set operad is associated to commutative monoids. In each case, we get structures with or without unit, depending on our choice as regards the term of arity 0 of the operad.

PROPOSITION 1.1.17. *The category of associative monoids with unit is isomorphic to the category of algebras over the permutation operad. The category of associative monoids without unit is isomorphic to the category of algebras over the operad formed by dropping the term of arity 0 in the permutation operad.*

By dropping the term of arity 0, we mean that we consider a sub-operad of the permutation operad such that $\mathcal{A}s(0) = \emptyset$ and $\mathcal{A}s(r) = \Sigma_r$ for $r > 0$. Thus, this proposition gives the difference, announced in §1.1.16, between the unitary case, where we take an operad satisfying $\mathcal{A}s_+(0) = pt$, and the non-unitary case, where we take $\mathcal{A}s(0) = \emptyset$.

PROOF. Let A be an associative monoid with unit. To a permutation $w \in \Sigma_r$, we can associate the operation $w : A^{\times r} \rightarrow A$ such that $w(a_1, \dots, a_r) = a_{w(1)} \cdot \dots \cdot a_{w(r)}$. In plain terms, this operation is formed by the r -fold product of the sequence of elements $a_{w(1)}, \dots, a_{w(r)}$ in the monoid A . In the case $r = 0$, we use the unit morphism $\eta : pt \rightarrow A$ (equivalent to an empty product) to define the operation assigned to the degenerate permutation $id_0 \in \Sigma_0$. The verification of the axioms of §1.1.13 is the matter of an easy understanding exercise. This process obviously gives a functor between the category of associative monoids with units and the category of algebras over the permutation operad.

In the converse direction, when A is an algebra over the permutation operad, we consider the unit operation $\eta : pt \rightarrow A$ associated to the degenerate permutation $id_0 \in \Sigma_0$ and the binary operation $\mu : A \times A \rightarrow A$ associated to the identity permutation $id_2 \in \Sigma_2$ in arity $r = 2$. The identity permutation in arity one $1 = id_1 \in \Sigma_1$ defines the unit of the permutation operad and, as such, is supposed to act as the identity operation on A . The unit operation $\eta : pt \rightarrow A$ is naturally equivalent to an element $e \in A$ which represents the image of the point pt under η . The identities $id_2(id_0, id_1) = id_1 = id_2(id_1, id_0)$ and $id_2(id_2, id_1) = id_3 = id_2(id_1, id_2)$ in the permutation operation are respectively equivalent to the unit $\mu(e, a) = a = \mu(a, e)$ and associativity relation $\mu(\mu(a_1, a_2), a_3) = \mu(a_1, \mu(a_2, a_3))$ in A . Hence, we have a monoid with unit naturally associated to each algebra over the permutation operad. This correspondence obviously gives a functor which is strictly inverse to the previously considered functor, from associative monoids with units to algebras over

the permutation operad. This assertion finishes the proof of the first assertion of the proposition.

The second assertion follows from the same verification (simply drop the consideration of the degenerate permutation id_0 corresponding to the unit operation $\eta : pt \rightarrow A$ from our line of arguments). \square

PROPOSITION 1.1.18. *The category of commutative monoids with unit is isomorphic to the category of algebras over the one-point set operad. The category of commutative monoids without unit is isomorphic to the category of algebras over the operad formed by dropping the term of arity 0 in the one-point set operad.*

By dropping the term of arity 0, we mean again that we consider a sub-operad of the one-point set operad such that $Com(0) = \emptyset$ and $Com(r) = pt$ for $r > 0$. Thus, we retrieve the same difference as in Proposition 1.1.17 between the unitary case of our structure, where we take an operad satisfying $Com_+(0) = pt$, and the non-unitary case, where we take $Com(0) = \emptyset$.

In the next chapter, we establish a generalization of this proposition in the context of symmetric monoidal categories.

PROOF. The arguments are the same as in the case of algebras over the permutation operad (Proposition 1.1.17). The only difference is the following: the identity $(1\ 2) \cdot pt = pt$ in the one-point set operad implies, according the equivariance axiom of operad actions (diagram of Figure 1.7), that the element $pt \in pt(2)$ represents a symmetric operation $\mu : A \times A \rightarrow A$, for any algebra over the one-point set operad. This explains that the structures associated to the one-point set operad are commutative. \square

1.1.19. Unitary and non-unitary operads. In general, we say that an operad P_+ is unitary when we have $P_+(0) = \mathbb{1}$, the unit object of the ambient symmetric monoidal category. In the context of sets, this requirement reads $P_+(0) = pt$. In contrast, we say that an operad P is non-unitary when we have $P(0) = \emptyset$, the initial object of the base category. To be precise, when we use this definition, we assume that the base category has an initial object so that $X \otimes \emptyset = \emptyset \otimes X = \emptyset$. (These identities are particular cases of our colimit preservation requirement.) In a more general setting, we just define non-unitary operads by dropping the arity zero term from the definition of an operad in §1.1.1. 

The operad of unitary associative monoids As_+ and the operad of unitary commutative monoids Com_+ , defined in §1.1.16 in the set-theoretic context, are basic examples of unitary operads in sets. The operads As and Com , formed by dropping the arity 0 terms of these unitary operads As_+ and Com_+ , are basic instances of non-unitary operads.

The terminology of a unitary operad refers to the observation that the evaluation morphism of a P_+ -algebra gives a morphism $\lambda : P_+(0) \rightarrow A$ in arity $r = 0$, and if we assume $P_+(0) = pt$ (in the point set context), then this morphism is equivalent to a distinguished element in A , which in usual examples (like associative or commutative monoids) represents a unit of the structure. Because of this interpretation, we also use the expression of unitary operation to refer to the elements of the arity zero term of an operad. The non-unitary operads are operads which have no unitary operation.

In principle, our operads are supposed to be unital in the sense that they are equipped with a unit morphism $\eta : \mathbb{1} \rightarrow P(1)$ (corresponding to a unit element

$1 \in P(1)$ in the point-set context), and this has not to be confused with the requirement that an operad P_+ is unitary $P_+(0) = \mathbb{1}$. The notion of a non-unitary operad, similarly, has not to be confused with the complement of the class of unitary operads. In the point-set context, the unitary operations $p \in P_+(0)$ have not to be confused with the unit element $1 \in P_+(1)$ too. In general, we reserve the term of unital for references to operadic units, as opposed to the term unitary, which we use as a reference to unitary operations acting on algebras and for related structures. But there is no fixed convention in the literature. In particular, the expression of a unital operad is used in [134] for what we call a unitary operad.

1.1.20. *Unitary extensions of operads.* We consider the category formed by the unitary operads as objects and the operad morphisms $\phi : P \rightarrow Q$ which are the identity of the unit object $\mathbb{1}$ in arity 0 as morphisms. We adopt the convention to mark the consideration of fixed terms in operad categories by adding lower-scripts to our notation. We therefore use the expression $\mathcal{O}p_1$ for the category of unitary operads. In the case where the base category is equipped with the cartesian product as tensor structure, so that the unit object $\mathbb{1}$ is the final object of the category $*$, we may also use the notation $\mathcal{O}p_*$ (as in the foreword) instead of $\mathcal{O}p_1$. 

We similarly adopt the notation $\mathcal{O}p_0$ for the category formed by the non-unitary operads of §1.1.19. Recall that a non-unitary operad P is defined by assuming $P(0) = \emptyset$ when the base category satisfies the colimit requirement of §0.8 (as we assume all through this chapter). In this case, we regard the category of non-unitary operads with a subcategory of the whole category of operads. Note that a morphism $\phi(0) : P(0) \rightarrow Q(0)$ is automatically the identity when we have $P(0) = Q(0) = \emptyset$. In general, we just define the category of non-unitary operads by dropping arity-zero terms from all definitions.

We say that a non-unitary operad P admits a unitary extension when we have a unitary operad P_+ agreeing with P in arity $n > 0$, and of which composition operations extend the composition operations of P . When the base category satisfies the colimit requirement of §0.8, the extension condition implies that the canonical embedding $i_+ : P \rightarrow P_+$ defines a morphism in the category of operads. We often use an expression of the form $Q = P_+$ to assert that a given operad Q forms a unitary extension of another given (non-unitary) operad P .

We examine the definition of unitary extensions of operads more thoroughly in §3.2, after a comprehensive review of the definition of operadic composition structures addressed in §3.1. We immediately see that the underlying collection of a unitary extension P_+ is determined from the associated non-unitary operad P by the addition of the unit term $P_+(0) = \mathbb{1}$ in arity 0. We precisely explain in §3.2 that the composition structure of the unitary operad P_+ can be determined from the internal composition structure of the non-unitary operad P and extra operations which reflect composition products with the additional arity zero term of the unitary extension, but which can still be defined in terms of the non-unitary part of the operad P_+ .

1.1.21. *Connected operads.* In subsequent constructions, we have to consider non-unitary operads P , satisfying $P(0) = \emptyset$ (when we assume that the tensor product satisfies our colimit preservation requirement, as usual), and so that $P(1) = \mathbb{1}$. We say that the operad P is connected when these conditions are satisfied. We adopt the notation $\mathcal{O}p_{01}$ (with the lower-scripts hinting the operad first terms) for the category of connected operads, regarded as a full subcategory of the category 

of operads $\mathcal{O}p$ (observe that the preservation of operadic unit implies that any morphism of connected operads is the identity of the unit object in arity 1).

We will similarly consider operads \mathcal{P}_+ , which are unitary in the sense of §1.1.19, and satisfy $\mathcal{P}_+(1) = \mathbb{1}$ as an extra requirement. We then say that the operad \mathcal{P}_+ is connected as a unitary operad. We adopt the notation $\mathcal{O}p_{11}$ for the full subcategory of the category of unitary operads $\mathcal{O}p_1$ generated by the connected unitary operads.

To give basic examples, we immediately see that the non-unitary associative operad \mathbf{As} and the non-unitary commutative operad \mathbf{Com} are instances of connected operads, while the unitary version of these operads \mathbf{As}_+ and \mathbf{Com}_+ are connected as unitary operads.

We go back to the definition of connected operads at the end of the next section.

1.2. Categorical constructions on operads

In this section, we explain the definition of free objects in the category of operads and the definition of operads by generators and relations. We also examine the definition of usual categorical constructions, like colimits and limits, in the context of operads.

For these purposes, we naturally have to consider the structure, underlying an operad, formed by a sequence $M = \{M(r)\}_{r \in \mathbb{N}}$ such that each $M(r)$, $r \in \mathbb{N}$, is an object of the base category equipped with an action of the symmetric group Σ_r . We generally use the expression of symmetric sequence to refer to these objects and the notation Seq to refer to the associated category, whose morphisms $f : M \rightarrow N$ obviously consist of sequences of morphisms in the base category $f : M(r) \rightarrow N(r)$, $r \in \mathbb{N}$, commuting with the action of symmetric groups.

We may also use the noun of Σ -sequence (rather than the expression in plain words) to refer to these symmetric sequences. We adopt the notation Σ (with no decoration) to refer the category which has the finite ordinals $\underline{n} = \{1 < \dots < n\}$, $n \in \mathbb{N}$, as objects and of which morphism sets are defined by $\mathit{Mor}_\Sigma(\underline{m}, \underline{n}) = \Sigma_n$ if $m = n$, and $\mathit{Mor}_\Sigma(\underline{m}, \underline{n}) = \emptyset$ otherwise. The symmetric sequences are then identified with diagrams over this category Σ . In our expression, the word ‘sequence’ refers to the sequence of finite ordinals $\underline{n} = \{1 < \dots < n\}$, $n \in \mathbb{N}$, giving the shape of the collections underlying these diagrams. The notation Σ refers to the small category, encoding the internal structures associated with our diagrams, and in which we put our indexing objects. We adopt similar conventions for variants of these diagram structures, which we introduce later on.

We have an obvious forgetful functor $\omega : \mathcal{O}p \rightarrow \mathit{Seq}$ mapping an operad P to the underlying sequence $P = \{P(r)\}_{r \in \mathbb{N}}$, where we only retain the actions of the symmetric groups. The definition of free operads arises from the following theorem:

THEOREM 1.2.1. *The forgetful functor $\omega : \mathcal{O}p \rightarrow \mathit{Seq}$, from the category of operads to the category of symmetric sequences, has a left adjoint $\mathcal{O} : \mathit{Seq} \rightarrow \mathcal{O}p$ mapping any symmetric sequence $M \in \mathit{Seq}$ to an associated free operad $\mathcal{O}(M)$.*

This theorem is formally established in §II.A.3.

Intuitively, the free operad is the structure formed by all formal operadic composites of generating elements $\xi \in M(n)$ with no relation between them apart from the universal relations which can be deduced from the axioms of operads. In §II.A.3, we use an extension of the tree representation of §§1.1.5-1.1.6 to give an explicit construction of such structures.

To obtain our result, we also use a new definition of the composition structure of an operad, in terms of the partial composition operations of §1.1.4. In the approach of §II.A.3, we explicitly deal with a tree-wise representation which reflects the relations associated with these composition operations. The idea is that the level structures, underlying the representation of the full composition products of operads, can be forgotten when we depict elements of the free operad, because the unit and associativity relations of Figure 1.5-1.6 imply that the multi-fold composition products associated to different choices of level structure determine the same element in the free operad.

To give a simple example, the multiple partial composite $p = (1\ 5) \cdot (((x \circ_1 y) \circ_4 z) \circ_3 t)$, such that $x \in M(2)$, $y \in M(3)$, $z \in M(2)$, $t \in M(2)$, and where we also consider an action of the transposition $(1\ 5) \in \Sigma_6$, defines an element of the free operad $\mathcal{O}(M)$, which we will represent by the following picture:

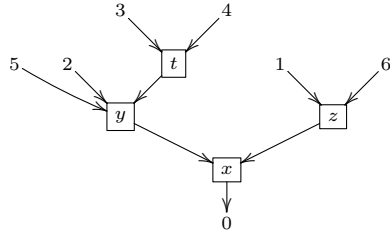

This tree-wise picture elaborates on a representation of partial composites which we introduce in §3.1.

For the moment, we can justify this picture by considering the formula $p = (1\ 5) \cdot x(y, 1)(1, 1, 1, z)(1, 1, t, 1, 1)$ arising from the definition of partial composition operations in §1.1.4. The element p can also be determined by a 3-fold composition product $p = (1\ 5) \cdot x(y, z)(1, 1, t, 1, 1)$, or equivalently, by $p = (1\ 5) \cdot x(y, 1)(1, 1, t, z)$. Each formula actually arises from the choice of a particular level structure on our tree representation. For instance, we have:

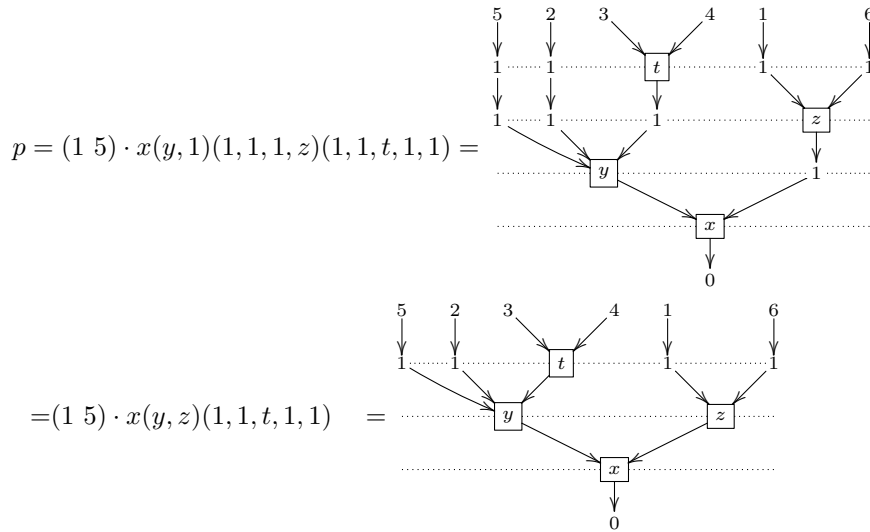

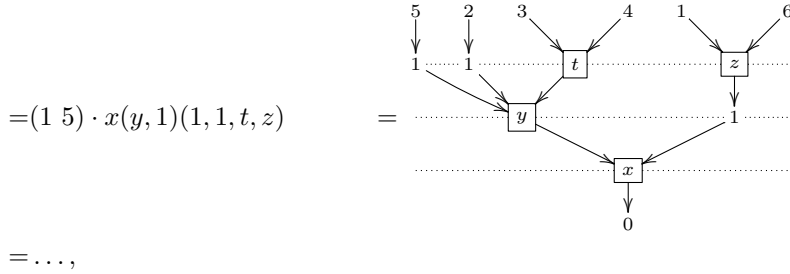

where the factors 1 represent operadic units. The identity between these representations follow (non trivially) from repeated applications of the unit and associativity relations of Figure 1.5-1.6.

By definition of an adjunction, the free operad is characterized by the existence of a functorial bijection

$$(*) \quad \text{Mor}_{\mathcal{O}p}(\mathcal{O}(M), P) \simeq \text{Mor}_{Seq}(M, P),$$

given for any pair (M, P) such that $M \in Seq$ and $P \in \mathcal{O}p$. Together with the adjunction relation, we have:

- a morphism of symmetric sequences $\iota : M \rightarrow \mathcal{O}(M)$, the unit of the adjunction, naturally associated to any $M \in Seq$, which corresponds to the identity of the free operad $id : \mathcal{O}(M) \rightarrow \mathcal{O}(M)$ under $(*)$;
- an operad morphism $\lambda : \mathcal{O}(P) \rightarrow P$, called the adjunction augmentation, naturally associated to any operad $P \in \mathcal{O}p$, and which, under $(*)$, corresponds to the identity of the operad P , viewed as an object of the category of symmetric sequences.

Intuitively, the adjunction augmentation λ is the morphism which applies the formal operadic composites of the free operad $\mathcal{O}(P)$ to their evaluation in P .

In §II.A.3, we address the explicit construction of the free operad $\mathcal{O}(M)$ and of the morphism $\iota : M \rightarrow \mathcal{O}(M)$ before establishing the adjunction relation. Indeed, our correspondence (a) is defined by associating the composite $\phi \cdot \iota \in \text{Mor}_{Seq}(M, P)$ with any operad morphism $\phi \in \text{Mor}_{\mathcal{O}p}(\mathcal{O}(M), P)$, and the proof that this mapping defines a bijection amounts to the following result:

PROPOSITION 1.2.2. *Any morphism of symmetric sequences $f : M \rightarrow P$, where P is an operad, admits a unique factorization*

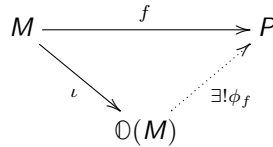

such that ϕ_f is an operad morphism.

This proposition, proved in §II.A.3, expresses the adjunction relation of Theorem 1.2.1 in terms of an equivalent universal property, which is usually given in the literature as the definition of a free object (we refer to [122, §IV.1] for the relationship between adjunctions and universals).

1.2.3. *The unit operad.* The purpose of the next paragraphs is to examine the definition of colimits and limits in the context of operads.

To start with, we consider the symmetric sequence

$$I(r) = \begin{cases} \mathbb{1}, & \text{if } r = 1, \\ \emptyset, & \text{otherwise,} \end{cases}$$

which reduces to a unit object in arity $r = 1$. This symmetric sequence inherits an obvious operad structure: the unit morphism $\mathbb{1} \xrightarrow{\eta} \mathbb{1} = I(1)$ is the identity morphism of $\mathbb{1}$; the composition products are forced by the unit axiom of Figure 1.2.

For a given operad P , we have one and only one operad morphism from I to P , which is simply given by the operadic unit $I(1) = \mathbb{1} \rightarrow P(1)$ in arity 1. (The preservation of operad unit forces the definition of such a morphism.) Thus, the object I , which we call the unit operad in what follows, defines the initial object of $\mathcal{O}p$. In general, we adopt the notation of the operadic unit η for the initial morphism $\eta : I \rightarrow P$ attached to this object because this initial morphism has only one component, in arity one, which represents the unit morphism §1.1.1(a) of the operad P .

The category of operads has a terminal object too, given by the terminal object of \mathcal{M} in each arity.

The category of symmetric sequences, like any category of diagrams, has colimits and limits of any kind, which are formed termwise in the ground category. In the context of operads, we obtain the following general proposition:

PROPOSITION 1.2.4.

- (a) *The forgetful functor from operads to symmetric sequences creates all limits, the filtered colimits, and the coequalizers which are reflexive in the category of symmetric sequences.*
- (b) *The category of operads admits coproducts too and, as a consequence, all small colimits, though the forgetful functor from operads to symmetric sequences does not preserve colimits in general.*

We refer to the appendix section §1.4 for recollections on filtered colimits and reflexive coequalizers.

PROOF. Let $\{P_\alpha\}_{\alpha \in \mathcal{J}}$ be any diagram in the category of operads. The collection

$$(\lim_{\alpha \in \mathcal{J}} P_\alpha)(r) = \lim_{\alpha \in \mathcal{J}} (P_\alpha(r)),$$

defined by the termwise limits of the diagrams $\{P_\alpha(r)\}_{\alpha \in \mathcal{J}}$ in the ground category, inherit a natural operadic composition product

$$\{\lim_{\alpha \in \mathcal{J}} P_\alpha(r)\} \otimes \{\lim_{\alpha \in \mathcal{J}} P_\alpha(n_1)\} \otimes \cdots \otimes \{\lim_{\alpha \in \mathcal{J}} P_\alpha(n_r)\} \rightarrow \lim_{\alpha \in \mathcal{J}} \{P_\alpha(n_1 + \cdots + n_r)\},$$

for any $r \geq 0$ and $n_1, \dots, n_r \geq 0$, which is given by the composite of the morphism

$$\lim_{\alpha \in \mathcal{J}} \{P_\alpha(r) \otimes P_\alpha(n_1) \otimes \cdots \otimes P_\alpha(n_r)\} \rightarrow \lim_{\alpha \in \mathcal{J}} \{P_\alpha(n_1 + \cdots + n_r)\},$$

induced by the composition products of the operads P_α , with the natural morphism

$$\begin{aligned} \{\lim_{\alpha \in \mathcal{J}} P_\alpha(r)\} \otimes \{\lim_{\alpha \in \mathcal{J}} P_\alpha(n_1)\} \otimes \cdots \otimes \{\lim_{\alpha \in \mathcal{J}} P_\alpha(n_r)\} \\ \rightarrow \lim_{\alpha \in \mathcal{J}} \{P_\alpha(r) \otimes P_\alpha(n_1) \otimes \cdots \otimes P_\alpha(n_r)\} \end{aligned}$$

deduced from the universal property of limits. The operad units $\eta : \mathbb{1} \rightarrow P_\alpha(1)$ yield a unit morphism on the limit too. We readily deduce from the uniqueness requirement in the universal property of limits that the axioms of operads are fulfilled in $\lim_{\alpha \in \mathcal{J}} P_\alpha$, and we also easily check that this operad, formed by a termwise limit, represents the limit of the diagram $\{P_\alpha\}_{\alpha \in \mathcal{J}}$ in the category of operads. The requirement that the morphisms $P \rightarrow P_\alpha$ preserve operad structures clearly forces this definition of the structure of our operad P . Therefore, we say that the forgetful functor creates limits.

In the case of colimits, we can not adapt the above construction to provide the termwise colimit

$$(\operatorname{colim}_{\alpha \in \mathcal{J}} P_\alpha)(r) = \operatorname{colim}_{\alpha \in \mathcal{J}} (P_\alpha(r))$$

with an operadic composition structure, at least in general, because we have a morphism in the wrong direction:

$$\begin{aligned} \{\operatorname{colim}_{\alpha \in \mathcal{J}} P_\alpha(r)\} \otimes \{\operatorname{colim}_{\alpha \in \mathcal{J}} P_\alpha(n_1)\} \otimes \cdots \otimes \{\operatorname{colim}_{\alpha \in \mathcal{J}} P_\alpha(n_r)\} \\ \leftarrow \operatorname{colim}_{\alpha \in \mathcal{J}} \{P_\alpha(r) \otimes P_\alpha(n_1) \otimes \cdots \otimes P_\alpha(n_r)\}. \end{aligned}$$

Nevertheless, the results of Proposition 1.4.2 and Proposition 1.4.4 imply that this morphism is iso when the diagrams $\{P_\alpha(n)\}_{\alpha \in \mathcal{J}}$ are shaped on a filtered category or form reflexive coequalizers in the ground category. Hence, in these situations, we can form natural composition products

$$\{\operatorname{colim}_{\alpha \in \mathcal{J}} P_\alpha(r)\} \otimes \{\operatorname{colim}_{\alpha \in \mathcal{J}} P_\alpha(n_1)\} \otimes \cdots \otimes \{\operatorname{colim}_{\alpha \in \mathcal{J}} P_\alpha(n_r)\} \rightarrow \operatorname{colim}_{\alpha \in \mathcal{J}} \{P_\alpha(n_1 + \cdots + n_r)\}$$

by composition of the morphisms

$$\operatorname{colim}_{\alpha \in \mathcal{J}} \{P_\alpha(r) \otimes P_\alpha(n_1) \otimes \cdots \otimes P_\alpha(n_r)\} \rightarrow \operatorname{colim}_{\alpha \in \mathcal{J}} \{P_\alpha(n_1 + \cdots + n_r)\}$$

induced by the composition products of the operads P_α with colimit isomorphism. The unit morphisms $\eta : \mathbb{1} \rightarrow P_\alpha(1)$, composed with the canonical morphisms $P_\alpha(1) \rightarrow \operatorname{colim}_{\alpha \in \mathcal{J}} P_\alpha(1)$, also give a canonical unit towards the colimit $\operatorname{colim}_{\alpha \in \mathcal{J}} P_\alpha(1)$. We easily check, again, that the axioms of operad are fulfilled in $\operatorname{colim}_{\alpha \in \mathcal{J}} P_\alpha$ and that this operad, formed by a termwise colimit, represents the colimit of the diagram $\{P_\alpha\}_{\alpha \in \mathcal{J}}$ in the category of operads.

To realize a coproduct of a collection of operads P_α , $\alpha \in \mathcal{J}$, we form a reflexive coequalizer of the form

$$\begin{array}{ccc} & \xleftarrow{s_0} & \\ \mathbb{O}(\coprod_{\alpha \in \mathcal{J}} \mathbb{O}(P_\alpha)) & \xrightleftharpoons[d_1]{d_0} & \mathbb{O}(\coprod_{\alpha \in \mathcal{J}} P_\alpha) \cdots \cdots \rightarrow Q \end{array}$$

where the morphisms (d_0, d_1) are determined on each generating summand $\mathbb{O}(P_\alpha)$ of the free operad $Q_1 = \mathbb{O}(\coprod_{\alpha \in \mathcal{J}} \mathbb{O}(P_\alpha))$ by:

- the morphism $\mathbb{O}(\iota_\alpha) : \mathbb{O}(P_\alpha) \rightarrow \mathbb{O}(\coprod_{\alpha \in \mathcal{J}} P_\alpha)$ induced by the canonical embedding $\iota_\alpha : P_\alpha \rightarrow \coprod_{\alpha \in \mathcal{J}} P_\alpha$ as regards d_0 ;
- the composite of the adjunction augmentation $\lambda : \mathbb{O}(P_\alpha) \rightarrow P_\alpha$ with the canonical embedding $\iota_\alpha : P_\alpha \rightarrow \coprod_{\alpha \in \mathcal{J}} P_\alpha$ and the adjunction unit of the free operad $\iota : \coprod_{\alpha \in \mathcal{J}} P_\alpha \rightarrow \mathbb{O}(\coprod_{\alpha \in \mathcal{J}} P_\alpha)$ as regards d_1 .

The reflection s_0 is given by the adjunction unit of the free operad $\iota : P_\alpha \rightarrow \mathbb{O}(P_\alpha)$ on each generating summand of $Q_0 = \mathbb{O}(\coprod_{\alpha \in \mathcal{J}} P_\alpha)$. By the result established in the

first part of the proposition, the existence of this reflection s_0 implies the existence of the coequalizer $\text{coker}(d_0, d_1)$ in the category of operads.

By the universal property of sums and free operads, any morphism $\phi_f : \mathbb{Q}_0 \rightarrow R$ towards an operad R is fully determined by a collection of symmetric sequence morphisms $f_\alpha : P_\alpha \rightarrow R$. Moreover, we have $\phi_f d_0 = \phi_f d_1$ if and only if the diagram

$$\begin{array}{ccc} \mathbb{O}(P_\alpha) & \xrightarrow{\lambda} & P_\alpha \\ & \searrow \phi_{f_\alpha} & \downarrow f_\alpha \\ & & R \end{array}$$

commutes for every α , where we consider the operad morphism ϕ_{f_α} associated to f_α . We readily see that this assertion amounts to the requirement that f_α preserves operadic composites and operad units, because λ is given by the evaluation of formal operad composites of the free operad in P_α and maps the unit of the free operad to the unit of P_α . Hence we have $\phi_f d_0 = \phi_f d_1$ if and only if each $f_\alpha : P_\alpha \rightarrow R$ is an operad morphism, and this implies that the definition of an operad morphism $\bar{\phi}_f : \text{coker}(d_0, d_1) \rightarrow R$ is equivalent to giving operad morphisms $f_\alpha : P_\alpha \rightarrow R$. We conclude that our coequalizer $\mathbb{Q} = \text{coker}(d_0, d_1)$ represents the coproduct of the operads P_α (in the category of operads), which therefore exists, as claimed in the proposition.

The last assertion of the proposition is an application of the result of Proposition 1.4.5, in the appendix section 1.4. \square

1.2.5. *Operads defined by generators and relations.* The existence of free objects and coequalizers enables us to define operads by generators and relations. To start with, we explain this process in the case where the base category is the category of sets $\mathcal{M} = \text{Set}$.

We start with a symmetric sequence $M \in \text{Seq}$, whose elements $\xi \in M(r)$ represents generating operations, and a collection of pairs $(w_0^\alpha, w_1^\alpha) \in \mathbb{O}(M)(n_\alpha)^{\times 2}$, $\alpha \in \mathcal{J}$, in order to define generating relations $w_0^\alpha \equiv w_1^\alpha$ within the free operad $\mathbb{O}(M)$.

We first form the free Σ_n -set $R(n) = \Sigma_n \otimes \{e_\alpha, \alpha \in \mathcal{J} | n_\alpha = n\}$, where each e_α denotes an abstract generating element associated to the indexing variable $\alpha \in \mathcal{J}$. The expression $G \otimes K$ is a general notation for the free G -object associated to any K in a base category \mathcal{M} . In other contexts, we use the notation $K[G]$ for this tensor product. In the case of sets, we can identify this object $K[G] = K \otimes G$ with the cartesian product of G and K .

We consider the symmetric sequence R formed by the collection $R(n)$, $n \in \mathbb{N}$. We have symmetric sequence morphisms $\rho_0, \rho_1 : R \rightrightarrows \mathbb{O}(M)$ such that $\rho_0(e_\alpha) = w_0^\alpha$ and $\rho_1(e_\alpha) = w_1^\alpha$ respectively. We form the morphisms of symmetric sequences $\delta_0, \delta_1 : M \amalg R \rightarrow \mathbb{O}(M)$ induced by $\rho_0, \rho_1 : R \rightrightarrows \mathbb{O}(M)$ on R and by the universal morphism $\iota : M \rightarrow \mathbb{O}(M)$ on M . We consider the morphisms of free operads $d_0, d_1 : \mathbb{O}(M \amalg R) \rightrightarrows \mathbb{O}(M)$ induced by these morphisms δ_0 and δ_1 . We have an operad morphism in the converse direction $s_0 : \mathbb{O}(M) \rightarrow \mathbb{O}(M \amalg R)$, yielded by the composite $M \hookrightarrow M \amalg R \xrightarrow{\iota} \mathbb{O}(M \amalg R)$, and such that $d_0 s_0 = d_1 s_0 = \text{id}$. The reflexive coequalizer $P = \text{coker}\{\mathbb{O}(M \amalg R) \rightrightarrows \mathbb{O}(M)\}$, created in the category of sets, defines the operad

$$P = \mathbb{O}(M : w_0^\alpha = w_1^\alpha, \alpha \in \mathcal{J})$$

associated to the generating symmetric sequence M together with the generating relations $w_0^\alpha \equiv w_1^\alpha$, $\alpha \in \mathcal{J}$,

Intuitively, the formation of the reflexive coequalizer $\text{coker}\{\mathbb{O}(M \amalg R) \rightrightarrows \widehat{\mathbb{O}(M)}\}$ in the underlying category of sets amounts to identifying any formal composites involving a subfactor of the form w_0^α with the same formal composite but where w_0^α is replaced by w_1^α .

For an operad morphism $\phi_f : \mathbb{O}(M) \rightarrow \mathbb{Q}$, we have:

$$\begin{aligned} \phi_f \cdot d_0 &= \phi_f \cdot d_1 \\ \Leftrightarrow \phi_f \cdot \rho_0 &= \phi_f \cdot \rho_1 \\ \Leftrightarrow \phi_f(w_0^\alpha) &= \phi_f(w_1^\alpha), \forall \alpha \in \mathcal{J}. \end{aligned}$$

Hence, the definition of a morphism $\bar{\phi}_f : P \rightarrow Q$ on $P = \mathbb{O}(M : w_0^\alpha = w_1^\alpha, \alpha \in \mathcal{J})$ amounts to giving a morphism of symmetric collections $f : M \rightarrow Q$ so that the extension of this morphism to the free operad $\phi_f : \mathbb{O}(M) \rightarrow Q$ maps the relations $w_0^\alpha \equiv w_1^\alpha$, $\alpha \in \mathcal{J}$, to actual identities in the target operad Q .

1.2.6. *Basic examples of operads in sets.* The most classical examples of operads are actually defined by a presentation by generators and relations. To give first examples of application of this process in the context of sets, we explain the presentation of the associative operad As , and of the commutative operad Com , the first instances of operad considered in the introductory sections §1.1. We focus on the non-unitary version of these operads for the moment. As we explain in §1.2.8, we will devote a subsequent chapter §3 to the definition of unitary operads in a general context, and therefore, we only give short indications on the presentation of the unitary associative (commutative) operad for the moment.

To give a more intuitive interpretation of our construction, we define the generating symmetric sequence of our operads M by giving operations $p = p(x_1, \dots, x_n)$ which generate the terms of this sequence $M(n)$ as Σ_n -sets. We use explicit variables to specify the arity of generating operations, unless this information has already been specified by the context. We may also use variable permutations to denote operations which correspond under the action of symmetric groups, but this indication may not be sufficient to determine the symmetric structure of our generating collection. Hence, we may have to add this precision.

The associative operad admits a presentation of the form

$$As = \mathbb{O}(\mu(x_1, x_2), \mu(x_2, x_1) : \mu(\mu(x_1, x_2), x_3) \equiv \mu(x_1, \mu(x_2, x_3))),$$

with a single generating operation $\mu = \mu(x_1, x_2)$ in arity 2, on which the group Σ_2 operates freely, together with the associativity relation, expressed by the composite identity $\mu(\mu, 1) \equiv \mu(1, \mu)$, as single generating relation. The commutative operad admits a presentation of the form

$$Com = \mathbb{O}(\mu(x_1, x_2) : \mu(\mu(x_1, x_2), x_3) \equiv \mu(x_1, \mu(x_2, x_3))),$$

with a single generating operation $\mu = \mu(x_1, x_2)$ in arity 2, on which the group Σ_2 operates trivially, together with the associativity relation $\mu(\mu, 1) \equiv \mu(1, \mu)$ as generating relation again.

In §1.1, we observed that we can use the permutation operad (respectively, the one-point set operad) to give a direct construction of an operad governing associative (respectively, commutative) algebras. The next proposition establishes the identity between this approach and the definition by generators and relations,

and gives, in a sense, an operadic counterpart of the result of Proposition 1.1.17-1.1.18.

PROPOSITION 1.2.7.

(a) *The set-theoretic operad \mathbf{As} , as defined in §1.2.6, satisfies*

$$\mathbf{As}(r) = \begin{cases} \emptyset, & \text{if } r = 0, \\ \Sigma_r, & \text{otherwise,} \end{cases}$$

and is identified with the (non-unitary version of the) permutation operad of Proposition 1.1.9.

(b) *The set-theoretic operad \mathbf{Com} , as defined in §1.2.6, satisfies*

$$\mathbf{Com}(r) = \begin{cases} \emptyset, & \text{if } r = 0, \\ pt, & \text{otherwise,} \end{cases}$$

and is identified with the (non-unitary version of the) one-point set operad of Proposition 1.1.10.

PROOF. We focus on the example of the associative operad (a) as the case of the commutative operad (b) follows from similar arguments. We use the temporary notation Π for the permutation operad. We consider, to be precise, the non-unitary version of this operad with the term in arity 0 withdrawn (as specified in the proposition).

To start with, we observe (as in the proof of Proposition 1.1.17) that the permutation $\mu = id \in \Sigma_2$ satisfies the generating relations of the associative operad \mathbf{As} in the permutation operad. Hence, we have a well-defined operad morphism $\phi : \mathbf{As} \rightarrow \Pi$ mapping the generating operation of \mathbf{As} to this permutation. To prove that this morphism is iso, we form a morphism in the converse direction by assigning the composite operation $\psi(w) = w \cdot \mu(\cdots (\mu(\mu, 1), 1), \dots, 1)$ to any $w \in \Sigma_r$. We immediately see that $\phi\psi = id$ and we easily obtain that $id \equiv \psi\phi$ from the relations of \mathbf{As} . The conclusion follows. \square

1.2.8. *The presentation of unitary operads.* To define unitary versions of the commutative operad and of the associative operad, we may simply add a generating operation e in arity 0 and relations of the form $\mu(e, 1) = 1 = \mu(1, e)$, expressing the neutral element identities, to our presentations. Thus, we may set

$$\begin{aligned} \mathbf{As}_+ &= \mathcal{O}(e, \mu(x_1, x_2), \mu(x_2, x_1) : \mu(\mu, 1) \equiv \mu(1, \mu), \mu(e, 1) \equiv 1 \equiv \mu(1, e)), \\ \mathbf{Com}_+ &= \mathcal{O}(e, \mu(x_1, x_2) : \mu(\mu, 1) \equiv \mu(1, \mu), \mu(e, 1) \equiv 1 \equiv \mu(1, e)), \end{aligned}$$

to define these operads. The result of Proposition 1.2.7 also extends to the unitary version of our operads, so that we have $\mathbf{As}_+(r) = \Sigma_r$ (respectively, $\mathbf{Com}_+(r) = pt$), for all r (including $r = 0$), and similarly in the \mathbb{k} -module setting.

But we may also consider that the generating unitary operation e is special (at least in our examples). Indeed, in the outcome of the presentation process, the terms of arity $r > 0$ of the operad \mathbf{As}_+ (respectively, \mathbf{Com}_+) agrees with the terms of the non-unitary operad \mathbf{As} , formed by dropping the unitary operation e from the presentation.

We need to put arity 0 terms apart in certain constructions. We therefore do not use the general approach of operads defined by generators and relations in the unitary case, and we put off further studies of unitary operads until §3.

1.2.9. *Operad ideals and presentations of operads in module categories.* The construction of §1.2.5 has an analogue in the context of modules over a ground ring: we simply have to replace the set $\{e_\alpha, \alpha \in \mathcal{J} | n_\alpha = n\}$ by the associated free \mathbb{k} -module $\mathbb{k}[e_\alpha, \alpha \in \mathcal{J} | n_\alpha = n]$, and we replace all set-theoretic constructions by their analogue in \mathbb{k} -modules. The purpose of this paragraph is to explain that, in the setting of module categories, we can use an operadic version of the notion of an ideal in order to obtain another approach to the construction of operads by generators and relations. In the next part of the book, we apply an extension of this construction in the graded context. For the moment, we focus on the case of plain modules.

In brief, an ideal of an operad in \mathbb{k} -modules P is a collection of submodules $S(n) \subset P(n)$, each of which preserved by the action of the symmetric group on $P(n)$, and so that any composite $p(q_1, \dots, q_r) \in P(n_1 + \dots + n_r)$ involving at least one factor in S remains in S . Equivalently, the collection S forms a sub-object of P in the category of symmetric sequences, and we have:

$$\begin{aligned} p(q_1, \dots, q_r) &\in S(n_1 + \dots + n_r), \\ &\text{for all } p \in P(r), \text{ and } q_1 \in P(n_1), \dots, q_r \in P(n_r), \\ &\text{as soon as } p \in S(r) \text{ or } q_i \in S(n_i) \text{ for some } i. \end{aligned}$$

We immediately see that the collection $P/S(n) = P(n)/S(n)$ obtained by forming the quotient of an operad P over an ideal S inherits an operad structure from P .

To a collection of elements $z^\alpha \in P(n_\alpha)$, $\alpha \in \mathcal{J}$, in an operad P , we associate the symmetric sequence $\langle z^\alpha, \alpha \in \mathcal{J} \rangle \subset P$ generated by the composites of the form $p(1, \dots, z^\alpha(q_1, \dots, q_{n_\alpha}), \dots, 1)$, where the factors p and q_1, \dots, q_{n_α} run over the whole operad P . We easily check, by using the axioms of operads, that this symmetric sequence $S = \langle z^\alpha, \alpha \in \mathcal{J} \rangle$ forms an ideal in P and is actually the smallest ideal including the elements z^α ($\alpha \in \mathcal{J}$). We can also easily check that an operad morphism $\phi : P \rightarrow Q$ factors through the quotient $P / \langle z^\alpha, \alpha \in \mathcal{J} \rangle$ if and only if we have $\phi(z^\alpha) = 0$ in Q , for all $\alpha \in \mathcal{J}$. Accordingly, in the case of a free operad $P = \mathbb{O}(M)$, any operad morphism $\bar{\phi}_f : \mathbb{O}(M) / \langle z^\alpha, \alpha \in \mathcal{J} \rangle \rightarrow Q$ is uniquely determined by a morphism of symmetric collections $f : M \rightarrow Q$ so that the extension of this morphism to the free operad $\phi_f : \mathbb{O}(M) \rightarrow Q$ cancels the generating elements of the ideal z^α , $\alpha \in \mathcal{J}$. From this observation, we conclude that, in the module context, we can define operads by generators and relations as quotients

$$\mathbb{O}(M : w_0^\alpha = w_1^\alpha, \alpha \in \mathcal{J}) = \mathbb{O}(M) / \langle w_0^\alpha - w_1^\alpha, \alpha \in \mathcal{J} \rangle,$$

where we replace our relations by equivalent differences before forming our ideal $S = \langle w_0^\alpha - w_1^\alpha, \alpha \in \mathcal{J} \rangle$.

1.2.10. *Basic examples of operads in module categories.* We can adapt the construction of §1.2.6 to define the module version of the associative (respectively, commutative) operad. We simply replace the generating sets of §1.2.6 by associated free modules (as explained in §1.2.9). We have

$$\begin{aligned} \mathbf{As} &= \mathbb{O}(\mathbb{k} \mu(x_1, x_2) \oplus \mathbb{k} \mu(x_2, x_1) : \mu(\mu(x_1, x_2), x_3) \equiv \mu(x_1, \mu(x_2, x_3))), \\ \mathbf{Com} &= \mathbb{O}(\mathbb{k} \mu(x_1, x_2) : \mu(\mu(x_1, x_2), x_3) \equiv \mu(x_1, \mu(x_2, x_3))), \end{aligned}$$

with, regarding the notation of generating operations, the same conventions as in the set-theoretic context.

Formally, the generating symmetric sequence of the associative operad is defined by $M_{\mathbf{As}}(2) = \mathbb{k}[\mu(x_1, x_2), \mu(x_2, x_1)] = \mathbb{k}[\Sigma_2]$ and $M_{\mathbf{As}}(n) = 0$ for $n \neq 2$. The generating symmetric sequence of the commutative operad in \mathbb{k} -modules is defined by $M_{\mathbf{Com}}(2) = \mathbb{k}[\mu(x_1, x_2)] = \mathbb{k}$ and $M_{\mathbf{Com}}(n) = 0$ for $n \neq 2$. According to §1.2.9, we can identify the associative operad and the commutative operad with quotients $\mathbf{As} = \mathcal{O}(M_{\mathbf{As}}) / \langle \mu(\mu, 1) - \mu(1, \mu) \rangle$ and $\mathbf{Com} = \mathcal{O}(M_{\mathbf{Com}}) / \langle \mu(\mu, 1) - \mu(1, \mu) \rangle$, where we consider the ideal generated by the difference $\mu(\mu(x_1, x_2), x_3) - \mu(x_1, \mu(x_2, x_3))$ to implement the associativity relation.

The next classical example of an operad which we consider is the Lie operad, defined by the presentation

$$\mathbf{Lie} = \mathcal{O}(\mathbb{k}\lambda(x_1, x_2) : \lambda(\lambda(x_1, x_2), x_3) + \lambda(\lambda(x_2, x_3), x_1) + \lambda(\lambda(x_3, x_1), x_2) \equiv 0),$$

where we have a single generating operation $\lambda = \lambda(x_1, x_2)$ in arity 2 together with the symmetric group action such that $(1\ 2) \cdot \lambda = -\lambda$. The generating symmetric sequence of the Lie operad is accordingly defined by $M_{\mathbf{Lie}}(n) = 0$ for $n \neq 2$ and $M_{\mathbf{Lie}}(2) = \mathbb{k}[\lambda(x_1, x_2)] = \mathbb{k}^\pm$, where \pm refers to a twist of the action of permutations by the signature. We can also realize this operad as a quotient of the free operad $\mathcal{O}(M_{\mathbf{Lie}})$ under the ideal generated by the element $\lambda(\lambda(x_1, x_2), x_3) + \lambda(\lambda(x_2, x_3), x_1) + \lambda(\lambda(x_3, x_1), x_2)$. This expression corresponds to the classical Jacobi identity of Lie algebras and the quotient by the associated operadic ideal implements this relation in the Lie operad.

In Proposition 1.2.7, we have established that the non-unitary associative (respectively, commutative) operad in sets is identified with the non-unitary version of the permutation (respectively, one-point set) operad. In §2.1, we will explain that the free \mathbb{k} -module functor $\mathbb{k}[-] : \mathbf{Set} \rightarrow \mathbf{Mod}$ induces a functor on operads, and we can use this process to associate an operad in \mathbb{k} -modules to any operad in sets. We can adapt the arguments of Proposition 1.2.7 to identify the operad \mathbf{As} (respectively, \mathbf{Com}), defined by generators and relations, with an operad in \mathbb{k} -modules associated with the non-unitary permutation (respectively, one-point set) operad. Consequently, we have

$$\mathbf{As}(r) = \begin{cases} 0, & \text{if } r = 0, \\ \mathbb{k}[\Sigma_r], & \text{otherwise,} \end{cases}$$

for the \mathbb{k} -module version of the associative operad and

$$\mathbf{Com}(r) = \begin{cases} 0, & \text{if } r = 0, \\ \mathbb{k}, & \text{otherwise,} \end{cases}$$

for the \mathbb{k} -module version of the commutative operad. In the next paragraph, we give another interpretation of these relations by going back to the representation of operad elements $p \in P(r)$ as abstract operations $p = p(x_1, \dots, x_r)$.

1.2.11. *The underlying symmetric sequence of classical operads.* The purpose of this paragraph is to review the interpretation of operad elements as abstract operations in the case of the usual operads \mathbf{As} , \mathbf{Com} , \mathbf{Lie} . To simplify, we still focus on the non-unitary version of the associative and commutative operads. The generating operations of these operads lie in arity $r > 0$, and similarly in the case of the Lie operad. This implies $\mathbf{Com}(0) = \mathbf{As}(0) = \mathbf{Lie}(0) = 0$. Thus we focus on the terms of arity $r > 0$.

In the case of the associative operad \mathbf{As} , an element $p(x_1, \dots, x_r) \in \mathbf{As}(r)$ is obtained by a multiple composition of an associative product $\mu(x_1, x_2) = x_1 \cdot x_2$ together with an appropriate variable shift ensuring that each variable x_i occurs once in the expression of $p(x_1, \dots, x_r)$. Consequently, the arity r term of the associative operad $\mathbf{As}(r)$ is identified with the module spanned by all monomials $p(x_1, \dots, x_r)$ of non-commutative variables (x_1, \dots, x_r) which have degree one with respect to each variable. In standard mathematical notation, such a monomial is written $p(x_1, \dots, x_r) = x_{i_1} \cdots x_{i_r}$, and the degree requirement amounts to the assumption that the sequence (i_1, \dots, i_r) forms a permutation of $(1, \dots, r)$. Hence, we obtain

$$\mathbf{As}(r) = \bigoplus_{s \in \Sigma_r} \mathbb{k}(x_{s(1)} \cdots x_{s(r)}) = \mathbb{k}[\Sigma_r], \quad \text{for all } r > 0,$$

and we retrieve the observation that $\mathbf{As}(r)$ is the regular representation of the symmetric group Σ_r .

Similarly, the arity r term of the commutative operad $\mathbf{Com}(r)$ is identified with the module spanned by all monomials $p(x_1, \dots, x_r)$ formed from a formal composite of products of commutative variables (x_1, \dots, x_r) so that each variable x_i occurs once and only once in $p(x_1, \dots, x_r)$. In standard algebraic language, this requirement amounts to assuming that $p(x_1, \dots, x_r)$ is a monomial of r commutative variables (x_1, \dots, x_r) which has degree one with respect to each variable. In standard mathematical notation, such a monomial is written $p(x_1, \dots, x_r) = x_1 \cdots x_r$. Hence, we immediately obtain

$$\mathbf{Com}(r) = \mathbb{k}(x_1 \cdots x_r) = \mathbb{k}, \quad \text{for all } r > 0,$$

from which we retrieve the identity between $\mathbf{Com}(r)$ and the free \mathbb{k} -module of rank one equipped with the trivial action of the symmetric group.

In the case of the Lie operad \mathbf{Lie} , we consider the module spanned by all Lie monomials $p(x_1, \dots, x_r)$ which have degree one with respect to each variable x_i . The determination of the module structure of $\mathbf{Lie}(r)$ is more intricate than in the case of the commutative and associative operads. Nevertheless one can prove (see [147, §5.6.2] for instance) that $\mathbf{Lie}(r)$ has a basis of the form

$$\mathbf{Lie}(r) = \bigoplus_{\substack{s \in \Sigma_r \\ s(1)=1}} \mathbb{k}[\cdots [[x_{s(1)}, x_{s(2)}], x_{s(3)}], \dots, x_{s(r)}], \quad \text{for all } r > 0,$$

where we use the Lie bracket notation $[-, -]$ for the generating operation of the operad \mathbf{Lie} . Hence, the \mathbb{k} -module $\mathbf{Lie}(r)$ is free of rank $(r-1)!$. In the case $\mathbb{Q}[e^{2i\pi/r}] \subset \mathbb{k}$, we also have an identity between $\mathbf{Lie}(r)$ and the induced representation $\mathbf{Lie}(r) = \text{Ind}_{C_r}^{\Sigma_r} \chi$ where C_r denotes the cyclic group generated by the r -cycle $(1 \ 2 \ \cdots \ r) \in \Sigma_r$ and χ denotes the one-dimensional representation of C_r associated to the character $\chi(1 \ 2 \ \cdots \ r) = e^{2i\pi/r}$ (see [147, §8.2] for a general reference on this subject).

1.2.12. *The example of the Poisson operad.* To complete our examples, we examine the definition of the Poisson operad, of which a graded version plays a significant role in the study of E_n -operads. This operad is defined by the presentation

$$\begin{aligned} \mathbf{Pois} &= \mathcal{O}(\mathbb{k}\mu(x_1, x_2) \oplus \mathbb{k}\lambda(x_1, x_2)) : \\ &\mu(\mu(x_1, x_2), x_3) = \mu(x_1, \mu(x_2, x_3)), \\ &\lambda(\lambda(x_1, x_2), x_3) + \lambda(\lambda(x_2, x_3), x_1) + \lambda(\lambda(x_3, x_1), x_2) = 0, \\ &\lambda(\mu(x_1, x_2), x_3) = \mu(\lambda(x_1, x_3), x_2) + \mu(x_1, \lambda(x_2, x_3)), \end{aligned}$$

where $\mu = \mu(x_1, x_2)$ is a symmetric generating operation, fixed by the action of the transposition $(1\ 2) \cdot \mu = \mu$, and $\lambda = \lambda(x_1, x_2)$ is an antisymmetric generating operation, which the transposition carries to its opposite $(1\ 2) \cdot \lambda = -\lambda$. From this construction, we see that the Poisson operad is a combination of the commutative operad $\mathbf{Com} = \mathcal{O}(\mathbb{k}\mu(x_1, x_2) : \mu(\mu(x_1, x_2), x_3) \equiv \mu(x_1, \mu(x_2, x_3)))$ and of the Lie operad $\mathbf{Lie} = \mathcal{O}(\mathbb{k}\lambda(x_1, x_2) : \lambda(\lambda(x_1, x_2), x_3) + \lambda(\lambda(x_2, x_3), x_1) + \lambda(\lambda(x_3, x_1), x_2) \equiv 0)$, together with an additional distribution relation

$$\lambda(\mu(x_1, x_2), x_3) = \mu(\lambda(x_1, x_3), x_2) + \mu(x_1, \lambda(x_2, x_3)),$$

called the Poisson relation, mixing both operads.

The commutative operad (respectively, the Lie operad) can be identified with the suboperad of the Poisson operad generated by the element $\mu \in \mathbf{Pois}(2)$ (respectively, $\lambda \in \mathbf{Pois}(2)$). The Poisson relation implies that each composite of a Lie operation with commutative operations (in that order) can be rewritten as a composite of a commutative operation with Lie operations. One can prove by elaborating on this remark that $\mathbf{Pois}(r)$ is identified with the \mathbb{k} -module spanned by formal products

$$p(x_1, \dots, x_r) = p_1(x_{11}, \dots, x_{1r_1}) \cdot \dots \cdot p_m(x_{m1}, \dots, x_{mr_m}),$$

of which factors $p_i(x_{i1}, \dots, x_{ir_i})$ run over Lie monomials on r_i variables x_{ik} , each variable x_{ik} occurring once and only once in $p_i(x_{i1}, \dots, x_{ir_i})$ (in other words, this Lie monomial has degree one with respect to each variable), and so that the variable subsets $\{x_{i1}, \dots, x_{ir_i}\}$ form a partition of the total set $\{x_1, \dots, x_r\}$. (Thus, each variable x_i also occurs once and only once in the complete expression $p(x_1, \dots, x_r)$.)

1.2.13. *Connected operads.* Recall that a connected operad in a base category \mathcal{M} is an operad P such that $P(0) = \emptyset$ and $P(1) = \mathbb{1}$.

If the base category is pointed, in the sense that initial and terminal objects coincide in \mathcal{M} , then any connected operad P inherits a natural augmentation $\epsilon : P \rightarrow I$, given by the identity in arity 1 and the terminal morphism otherwise. This augmentation obviously defines a morphism in the category of operads, and accordingly, the unit operad I gives a terminal object in the category of connected operads, in addition to form the initial object. Thus, the category of connected operads is pointed (unlike the whole category of operads) whenever the base category is so.

To a connected operad P , we associate the symmetric sequence \overline{P} such that

$$\overline{P}(r) = \begin{cases} \emptyset, & \text{if } r = 0, 1, \\ P(r), & \text{otherwise.} \end{cases}$$

We call this symmetric sequence the augmentation ideal of P , because we can identify it with the kernel of the augmentation morphism $\epsilon : P \rightarrow I$ when the

base category is pointed. We have to mention, however, that we may consider this symmetric sequence \overline{P} outside the pointed category context, where the above definition makes sense but not the augmentation ideal interpretation.

The category of connected operads is denoted by $\mathcal{O}p_{01}$, with added lower-scripts to mark the operad first terms $P(0) = \emptyset$, $P(1) = \mathbb{1}$. We similarly use the expression Seq_{00} to denote the category formed by symmetric sequences such that $M(0) = M(1) = \emptyset$. We say that a symmetric sequence satisfying these conditions is connected (as a symmetric sequence). The mapping $\overline{w} : P \mapsto \overline{P}$ gives a functor, denoted by $\overline{w} : \mathcal{O}p_{01} \rightarrow Seq_{00}$, from the category of connected operads $\mathcal{O}p_{01}$ towards the category of connected symmetric sequences Seq_{00} . In the connected context, we will use the following interpretation of the free operad construction:

THEOREM 1.2.14. *The free operad $\mathcal{O}(M)$ associated to a connected sequence $M \in Seq_{00}$ is connected as an operad and the map $\mathcal{O} : M \mapsto \mathcal{O}(M)$ defines a left adjoint of the functor $\overline{w} : \mathcal{O}p_{01} \rightarrow Seq_{00}$ mapping a connected operads $P \in \mathcal{O}p_{01}$ to its augmentation ideal $\overline{P} \in Seq_{00}$.*

This theorem, which is essentially a follow-up of Theorem 1.2.1, is formally established in §II.A.4 (by using the category of symmetric collections $Coll$, equivalent to the category of symmetric sequences Seq , as in the case of Theorem 1.2.1).

In general, an operad defined by generators and relations $P = \mathcal{O}(M : w_0^\alpha = w_1^\alpha, \alpha \in \mathcal{J})$ is connected (in our sense) if and only if the generating sequence M vanishes in arity $r = 0, 1$, essentially because this result holds for free operads. We retrieve (for instance) that the (non-unitary) associative operad \mathbf{As} is connected, like the (non-unitary) commutative operad \mathbf{Com} , and the Lie operad \mathbf{Lie} .

1.2.15. *The adjunctions between connected, non-unitary operads, and the complete category of operads.* We have an obvious embedding $\iota : \mathcal{O}p_{01} \hookrightarrow \mathcal{O}p_0$ from the category of connected operads $\mathcal{O}p_{01}$, characterized by $P(0) = \emptyset$ and $P(1) = \mathbb{1}$, to the category of non-unitary operads $\mathcal{O}p_0$, which are characterized by the single condition $P(0) = \emptyset$.

We can readily check that the category embedding $\iota : \mathcal{O}p_{01} \hookrightarrow \mathcal{O}p_0$ has a right adjoint $\tau : \mathcal{O}p_0 \rightarrow \mathcal{O}p_{01}$, which maps any non-unitary operad $P \in \mathcal{O}p_0$ to a connected operad τP defined by $\tau P(0) = \emptyset$, $\tau P(1) = \mathbb{1}$, and $\tau P(r) = P(r)$ for $r > 1$. We just use the unit morphism $\eta : \mathbb{1} \rightarrow P(1)$ to define a restriction of the composition products of the operad P when we deal with the factor of arity 1, so that this truncated symmetric sequence τP inherits an operadic composition structure. The proof of the adjunction relation is immediate.

We also have an obvious truncation functor $\tau : \mathcal{O}p \rightarrow \mathcal{O}p_0$ which is right adjoint to the category embedding $\iota : \mathcal{O}p_0 \rightarrow \mathcal{O}p$.

From our construction of limits and colimits of operads, we can readily check that:

PROPOSITION 1.2.16. *The category embeddings $\mathcal{O}p_{01} \hookrightarrow \mathcal{O}p_0 \hookrightarrow \mathcal{O}p$ create ~~limits and~~ colimits. \square*

1.3. Categorical constructions on algebras over operads

In the previous section, we focused on the application of categorical constructions to operads. We now study the applications of such constructions at the level of algebra categories associated to operads. We first explain, in the next paragraph, that the construction of operads by generators and relations reflects the definition

of usual algebra categories in terms of generating operations $\xi : A^{\otimes r} \rightarrow A$ satisfying given relations.

We also give a version of the categorical constructions of §1.2 (free objects, colimits and limits) in categories of algebras associated to operads. We will observe (following [134]) that the categories of algebras associated to operads can be characterized as categories of algebras equipped with free objects of a particular form. One can use this observation to retrieve results of the previous section concerning the terms of the usual operads. By the way, we establish that any operad morphism give rise to adjoint extension and restriction functors at the level of algebra categories. Examples include the standard functors connecting the categories of associative, commutative, and Lie algebras.

1.3.1. *Basic examples of algebra categories associated to operads.* Recall (see Proposition 1.1.15) that defining an action of an operad P on an object $A \in \mathcal{M}$ amounts to giving an operad morphism $\phi : P \rightarrow \mathbf{End}_A$, where \mathbf{End}_A denotes the endomorphism operad of A . In the case of an operad defined by generators and relations

$$P = \mathcal{O}(M : w_0^\alpha = w_1^\alpha, \alpha \in J),$$

we deduce, from the observations of §1.2.5, that such a morphism $\phi_f : P \rightarrow \mathbf{End}_A$ amounts to giving a morphism of symmetric sequences $f : M \rightarrow \mathbf{End}_A$, mapping the abstract generating operations $\xi \in M(r)$ to actual maps $\xi : A^{\otimes r} \rightarrow A$, and so that the identities $w_0^\alpha \equiv w_1^\alpha$ hold in \mathbf{End}_A .

For our basic examples of (non-unitary) operads in the category of \mathbb{k} -modules $P = \mathit{Com}, \mathit{As}, \mathit{Lie}$, we obtain:

- (a) an algebra over the commutative operad Com is a module A equipped with a product $\mu : A \otimes A \rightarrow A$ which satisfies the symmetry relation

$$\mu(a_1, a_2) = \mu(a_2, a_1),$$

for all $a_1, a_2 \in A$, and the associativity relation

$$\mu(\mu(a_1, a_2), a_3) = \mu(a_1, \mu(a_2, a_3)),$$

for all $a_1, a_2, a_3 \in A$;

- (b) an algebra over the associative operad As is a module A equipped with a product $\mu : A \otimes A \rightarrow A$ which satisfies the associativity relation

$$\mu(\mu(a_1, a_2), a_3) = \mu(a_1, \mu(a_2, a_3))$$

for all $a_1, a_2, a_3 \in A$ (but no symmetry requirement);

- (c) an algebra over the Lie operad Lie is a module \mathfrak{g} equipped with an operation $\lambda : \mathfrak{g} \otimes \mathfrak{g} \rightarrow \mathfrak{g}$ which satisfies the antisymmetry relation

$$\lambda(x_1, x_2) = -\lambda(x_2, x_1),$$

for all $x_1, x_2 \in \mathfrak{g}$, and the Jacobi identity

$$\lambda(\lambda(x_1, x_2), x_3) + \lambda(\lambda(x_2, x_3), x_1) + \lambda(\lambda(x_3, x_1), x_2) = 0,$$

for all $x_1, x_2, x_3 \in \mathfrak{g}$.

We can similarly identify the category of algebras associated to the Poisson operad from the presentation of §1.2.12.

In characteristic 2, we do not necessarily assume that the generating operation of a *Lie*-algebra \mathfrak{g} satisfies the relation $\lambda(x, x) = 0$ in contrast to the usual definition of a Lie algebra. To associate a category of algebras satisfying this condition to

the Lie operad *Lie*, we have to modify the definition of an algebra over an operad following a process explained in [59, §§1.2.12-1.2.16].

The result of Proposition 1.1.17-1.1.18 (in the non-unitary context) is equivalent to the combination of the assertions of (a-b) with Proposition 1.2.7.

1.3.2. *The category of algebras associated to an operad and free algebras.* Recall that the algebras associated to a given operad P form a category \mathcal{P} with, as morphisms, the morphisms of the ground category $f : A \rightarrow B$ which preserve the P -actions on A and B . We have an obvious forgetful functor $\omega : \mathcal{P} \rightarrow \mathcal{M}$ from the category of P -algebras \mathcal{P} towards the base category \mathcal{M} .

We can form a functor in the converse direction by considering a generalized symmetric tensor object

$$\mathbb{S}(P, X) = \prod_{n=0}^{\infty} (P(n) \otimes X^{\otimes n})_{\Sigma_n},$$

associated to any $X \in \mathcal{M}$, where the notation $(-)_{\Sigma_n}$ refers to a coinvariant quotient, identifying the natural Σ_n -action on the tensor power $X^{\otimes n}$ with the internal Σ_n -structure of $P(n)$. Let $p \in P(n)$ and $x_1 \otimes \cdots \otimes x_n \in X^{\otimes n}$. In the point-wise context, we formally set

$$p \otimes (x_{s(1)} \otimes \cdots \otimes x_{s(n)}) \equiv s \cdot p \otimes (x_1 \otimes \cdots \otimes x_n),$$

and $(P(n) \otimes X^{\otimes n})_{\Sigma_n}$ is the quotient under these relations, where we assume that s runs over the symmetric group Σ_n .

We have natural evaluation morphisms

$$P(r) \otimes \mathbb{S}(P, X)^{\otimes r} \xrightarrow{\lambda} \mathbb{S}(P, X)$$

given termwise by morphisms

$$\begin{aligned} P(r) \otimes (P(n_1) \otimes X^{\otimes n_1})_{\Sigma_{n_1}} \otimes \cdots \otimes (P(n_r) \otimes X^{\otimes n_r})_{\Sigma_{n_r}} \\ \rightarrow (P(n_1 + \cdots + n_r) \otimes X^{\otimes n_1 + \cdots + n_r})_{\Sigma_{n_1 + \cdots + n_r}} \end{aligned}$$

induced by the composition products of the operad. We easily check that the axioms of operads imply that these morphisms satisfy the equivariance, associativity and unit axioms of operad actions. We therefore obtain that the object $\mathbb{S}(P, X) \in \mathcal{M}$ forms a P -algebra, naturally associated to $X \in \mathcal{M}$, so that the mapping $\mathbb{S}(P) : X \mapsto \mathbb{S}(P, X)$ defines a functor $\mathbb{S}(P) : \mathcal{M} \rightarrow \mathcal{P}$.

For a P -algebra A , the evaluation morphisms of A induce morphisms $\lambda : (P(n) \otimes A^{\otimes n})_{\Sigma_n} \rightarrow A$ for all $n \geq 0$ by equivariance. These morphisms can be patched into a single natural morphism $\lambda : \mathbb{S}(P, A) \rightarrow A$ by the universal property of the coproduct $\mathbb{S}(P, A) = \coprod_{n=0}^{\infty} (P(n) \otimes A^{\otimes n})_{\Sigma_n}$. From the associativity axiom of operad actions, we easily check that $\lambda : \mathbb{S}(P, A) \rightarrow A$ preserves P -algebra structures and hence, defines a morphism in the category of P -algebras. In the converse direction, for any $X \in \mathcal{M}$, we have a natural morphism $\iota : X \rightarrow \mathbb{S}(P, X)$ given by the composite

$$X \xrightarrow{\simeq} \mathbb{1} \otimes X \xrightarrow{\eta \otimes X} P(1) \otimes X = (P(1) \otimes X)_{\Sigma_1} \hookrightarrow \prod_{n=0}^{\infty} (P(n) \otimes X^{\otimes n})_{\Sigma_n},$$

where η refers to the unit morphism of the operad P .

One checks that:

PROPOSITION 1.3.3. *The functor $\mathbb{S}(P) : \mathcal{M} \rightarrow \mathcal{P}$ is left adjoint to the forgetful functor $\omega : \mathcal{P} \rightarrow \mathcal{M}$. The morphism $\iota : X \rightarrow \mathbb{S}(P, X)$ (respectively, $\lambda : \mathbb{S}(P, A) \rightarrow A$) defines the unit (respectively, the augmentation) of this adjunction relation.*

Explicitly, this proposition asserts the existence of a bijection

$$\mathbf{Mor}_{\mathcal{P}}(\mathbb{S}(P, X), A) = \mathbf{Mor}_{\mathcal{M}}(X, A),$$

for any $X \in \mathcal{M}$ and any $A \in \mathcal{P}$. In one direction, to a morphism of P -algebras $\phi : \mathbb{S}(P, X) \rightarrow A$ we associate the morphism $f = \phi \cdot \iota$ in the base category. In the other direction, to a morphism in the base category $f : X \rightarrow A$ we associate the morphism $\phi_f = \lambda \cdot \mathbb{S}(P, f)$ in the category of P -algebras. The adjunction augmentation itself $\lambda : \mathbb{S}(P, A) \rightarrow A$ is the morphism of P -algebras ϕ_{id} associated to the identity of A , regarded as an object of the base category \mathcal{M} .

PROOF. By a general result of category theory (see [122, §IV.1]), we essentially have to check that the composites

$$A \xrightarrow{\iota} \mathbb{S}(P, A) \xrightarrow{\lambda} A \quad \text{and} \quad \mathbb{S}(P, X) \xrightarrow{\mathbb{S}(P, \iota)} \mathbb{S}(P, \mathbb{S}(P, X)) \xrightarrow{\lambda} \mathbb{S}(P, X)$$

are both identity morphisms to conclude that our mappings are converse to each other, and hence gives an adjunction relation well. This result follows from the unit axiom of operad actions in the first case and from the unit axiom of operads in the second one. \square

The result of Proposition 1.3.3 has, like Theorem 1.2.1, an equivalent formulation in terms of universal properties. In this point of view, the functor $\mathbb{S}(P) : \mathcal{M} \rightarrow \mathcal{P}$ is defined by the mapping which associates a free object in the category of P -algebras to any $X \in \mathcal{M}$.

Basically, the morphism of P -algebras ϕ_f associated to a given morphism f in the base category is characterized by the equation $\phi_f \cdot \iota = f$ since our adjunction is a bijection. Thus, for a fixed $X \in \mathcal{M}$, the result of Proposition 1.3.3 amounts to the following proposition:

PROPOSITION 1.3.4. *Any morphism in the base category $f : X \rightarrow A$, where A is a P -algebra, admits a unique factorization*

$$\begin{array}{ccc} X & \xrightarrow{f} & A \\ & \searrow \iota & \nearrow \exists! \phi_f \\ & \mathbb{S}(P, X) & \end{array}$$

such that ϕ_f is a morphism of P -algebras. \square

This statement gives the expression of the universal property of free object satisfied by the P -algebra $\mathbb{S}(P, X)$.

1.3.5. *Basic examples of free algebras.* The structure of the basic operads $P = \mathit{Com}, \mathit{As}, \mathit{Lie}$ can be retrieved from known expansions of free objects in the categories of algebras associated to these operads:

- (a) The free commutative algebra (without unit) is identified with (the augmentation ideal of) the symmetric algebra

$$\overline{\mathbb{S}}(K) = \bigoplus_{n=1}^{\infty} (K^{\otimes n})_{\Sigma_n}$$

together with a commutative product yielded by the process of tensor concatenations. From this observation, we immediately retrieve the identity $\mathbf{Com}(n) = \mathbb{k}$.

- (b) The free associative algebra (without unit) is identified with (the augmentation ideal of) the tensor algebra

$$\overline{\mathbb{T}}(K) = \bigoplus_{n=1}^{\infty} K^{\otimes n}$$

together with an associative product defined by the concatenation of tensors. We can retrieve the identity $\mathbf{As}(n) = \mathbb{k}[\Sigma_n]$ from this observation since $K^{\otimes n} = (\mathbb{k}[\Sigma_n] \otimes K^{\otimes n})_{\Sigma_n}$.

- (c) The structure of free Lie algebras is more intricate. Nevertheless, in characteristic 0, we can apply the Milnor-Moore theorem to identify the free Lie algebra $\mathbb{L}(K)$ with the primitive part of the tensor algebra $\mathbb{T}(K)$, where we use the formula $\Delta(x) = x \otimes 1 + 1 \otimes x$ to define the coproduct of any generating element $x \in K$. Moreover, we have versions of the Milnor-Moore theorem which enable us to deduce an expansion of the form

$$\mathbb{L}(K) = \bigoplus_{n=1}^{\infty} (\mathbf{Lie}(n) \otimes K^{\otimes n})_{\Sigma_n}$$

from the relation $\mathbb{L}(K) = \mathbb{P}\mathbb{T}(K)$. More details on this construction are given in §7.

We keep focusing on non-unitary algebras, but the identifications of (a-b) obviously extend to the unitary setting.

Proposition 1.2.4 has the following analogue for the category of algebras associated to an operad:

PROPOSITION 1.3.6. *Let P be any operad.*

- (a) *The forgetful functor from P -algebras to the ground category creates all kinds of small limits, the filtered colimits, and the coequalizers which are reflexive in the category of symmetric sequences.*
- (b) *The category of P -algebras admits coproducts too and, as a consequence, all kinds of small colimits, though the forgetful functor towards the ground category does not preserve colimits in general.*

Recall that we devote an appendix section §1.4 to recollections on filtered colimits and reflexive coequalizers.

PROOF. Same argument line as in the proof of Proposition 1.2.4. See also [60, §3.3] or [148, Proposition 2.3.5] for this proposition. \square

1.3.7. Restriction functors. If an operad morphism $\phi : P \rightarrow Q$ is given, then we can compare the category of P -algebras and the category of Q -algebras. First, we immediately observe that any Q -algebra B inherits a natural P -algebra structure since the operad P acts on B through Q by way of the morphism $\phi : P \rightarrow Q$. Thus we have a natural functor $\phi^* : \mathcal{Q} \rightarrow \mathcal{P}$, referred to as the restriction functor associated with ϕ , from the category of Q -algebras to the category of P -algebras. The existence of reflexive coequalizers can be used to define a morphism in the converse direction, so that:

PROPOSITION 1.3.8. *The restriction functor $\phi^* : \mathcal{Q} \rightarrow \mathcal{P}$, associated to any operad morphism $\phi : P \rightarrow Q$, has a left adjoint $\phi_! : \mathcal{P} \rightarrow \mathcal{Q}$, referred to as the extension functor associated with $\phi : P \rightarrow Q$.*

PROOF. Let $A \in \mathcal{P}$. Let $\phi_!A$ be the Q -algebra defined by the reflexive coequalizer such that

$$\mathbb{S}(Q, \mathbb{S}(P, A)) \begin{array}{c} \xrightarrow{d_0} \\ \xrightarrow{d_1} \end{array} \mathbb{S}(Q, A) \dashrightarrow \phi_!A,$$

s_0

where:

- the morphism d_0 is the morphism of free Q -algebras induced by the adjunction augmentation $\lambda : \mathbb{S}(P, A) \rightarrow A$ associated to the P -algebra A ;
- the morphism d_1 is induced by $\mathbb{S}(\phi, A) : \mathbb{S}(P, A) \rightarrow \mathbb{S}(Q, A)$, by using the functoriality of the generalized symmetric algebra construction with respect to the coefficients;
- and the reflection s_0 is the morphism of free Q -algebras induced by the universal morphism $\iota : A \rightarrow \mathbb{S}(P, A)$ of the free P -algebra $\mathbb{S}(P, A)$.

We can easily check, by using the universal property of free Q -algebras, that the definition of a morphism of Q -algebras $g : \phi_!A \rightarrow B$ amounts to the definition of a morphism $f : A \rightarrow B$ commuting with P -actions. Therefore the mapping $\phi_! : A \mapsto \phi_!A$ defines a left adjoint of the restriction functor $\phi^* : B \mapsto \phi^*B$. \square

1.3.9. *Basic examples of extension and restriction functors.* The commutative, associative and Lie operads are connected by morphisms

$$Lie \xrightarrow{\iota} As \xrightarrow{\alpha} Com$$

determined on generating operations $\lambda \in Lie(2)$, $\mu \in As(2)$ and $\mu \in Com(2)$, by the expressions $\iota(\lambda) = \mu - (1\ 2) \cdot \mu$ and $\alpha(\mu) = \mu$.

The restriction functor $\alpha^* : Com \rightarrow As$ is identified with the obvious embedding of the category of commutative algebras into the category of associative algebras. The restriction functor $\iota^* : As \rightarrow Lie$ is identified with the classical functor mapping an associative algebra A to the Lie algebra $\iota^*A = A_-$ with the same underlying module as A and the commutator $\lambda(a_1, a_2) = \mu(a_1, a_2) - \mu(a_2, a_1)$ as Lie bracket. Throughout this paragraph, we use the notation of the generating operadic operation λ and μ instead of the more usual notation $\lambda(a_1, a_2) = [a_1, a_2]$ and $\mu(a_1, a_2) = a_1a_2$ to mark the relationship of the constructions with our operad morphisms.

The extension functor $\alpha_! : As \rightarrow Com$, defined as the left adjoint of $\alpha^* : Com \rightarrow As$, can be identified with the functor mapping an associative algebra A to the quotient $A / \langle \lambda(A, A) \rangle$, where $\langle \lambda(A, A) \rangle$ refers to the two-sided ideal of A generated by the commutators $\lambda(a_1, a_2) = \mu(a_1, a_2) - \mu(a_2, a_1)$, $a_1, a_2 \in A$. The extension functor $\iota_! : Lie \rightarrow As$, defined as the left adjoint of $\iota^* : As \rightarrow Lie$, can be identified with the functor mapping a Lie algebra \mathfrak{g} to the augmentation ideal of the standard enveloping algebra $\mathbb{U}(\mathfrak{g})$, the quotient of the tensor algebra $\mathbb{T}(\mathfrak{g})$ by the two-sided ideal generated by the differences $\mu(a_1, a_2) - \mu(a_2, a_1) - \lambda(a_1, a_2)$, $a_1, a_2 \in \mathfrak{g}$, where μ refers to the product of $\mathbb{T}(\mathfrak{g})$ and λ to the Lie bracket of \mathfrak{g} . In all cases, we can easily check that the functors defined by these basic constructions satisfy the adjunction relation of extension functors and hence is isomorphic to the operadic extension functor of Proposition 1.3.8.

1.3.10. *Algebras over connected operads.* The structure of an algebra over the unit operad I (see §1.2.3) reduces to an identity operation, and hence, the category of I -algebras is simply nothing but the base category \mathcal{M} . In the context of a pointed category (see §1.2.13), the existence of an augmentation $\epsilon : P \rightarrow I$, when P is a connected operad, implies that any $X \in \mathcal{M}$ inherits the structure of an algebra over P , simply given by a trivial action in arity $r > 1$. In the context of \mathbb{k} -modules, the application of this construction to the classical examples $P = \mathit{Com}, \mathit{As}, \mathit{Lie}$ identifies a module with an abelian commutative (respectively, associative, Lie) algebra, on which the structure product (respectively, Lie bracket) is identically zero.

The extension functor $\epsilon_! : P \rightarrow \mathcal{M}$ associated to an augmentation $\epsilon : P \rightarrow I$ is identified with an indecomposable functor which, in the module context, amounts to killing the non-trivial operations $p(a_1, \dots, a_r)$, $r > 1$, occurring in a given P -algebra A . In the case $P = \mathit{As}$ (and in the case $P = \mathit{Com}$ similarly), this indecomposable functor $\epsilon_! : \mathit{As} \rightarrow \mathcal{M}$ can be defined by the standard construction $\epsilon_! A = A/A^2$ where A^2 refers to the submodule of A spanned by the products $\mu(a, b)$, for $a, b \in A$. In the case $P = \mathit{Lie}$, we obtain $\epsilon_! \mathfrak{g} = \mathfrak{g}/\Gamma_2(\mathfrak{g})$, where $\Gamma_2(\mathfrak{g})$ refers to the submodule of \mathfrak{g} spanned by the bracket $\lambda(a, b)$, for $a, b \in \mathfrak{g}$.

1.3.11. *Further remarks: operads and monads.* The use of the functor $\mathbb{S}(P)$ in operad theory goes back to [134], where it is observed that (a pointed space variant of) this functor $\mathbb{S}(P)$ defines a monad on the base category. The category of P -algebras is defined in terms of this monad $\mathbb{S}(P)$ in [134]. This definition is formally equivalent to the definition of §1.1.13 where we just consider (in the point of view of [134]) an expansion of the action of the monad $\mathbb{S}(P)$ on A . In the approach of [134], the result of Proposition 1.3.3 is a consequence of a general statement about algebras over monads (see [122, §VI.2]).

In fact, the definition of $\mathbb{S}(M) : X \mapsto \mathbb{S}(M, X)$ as a functor from the base category to itself makes sense for any symmetric collection M , and not only for operads. The category of symmetric sequence comes also equipped with structures, like a composition product, that reflect pointwise operations on functors (see [60] for an overall reference on this subject). These observations are the source of abstract categorical definitions for the notion of an operad. These definitions are not used in this book, but we can give a sketch of the ideas.

In the point of view of [134], the operads are exactly the symmetric sequences P such that $\mathbb{S}(P)$ inherits a monad structure. On the other hand, the category of functors $F : \mathcal{M} \rightarrow \mathcal{M}$ is equipped with a natural monoidal structure, defined by the pointwise composition operation, and monads can be defined abstractly as monoid objects in that category. In parallel, we can interpret the definition of the composition structure of an operad in §1.1.1, as the definition of an abstract monoid structure in the category of symmetric sequences with respect to the composition operation reflecting the composition structure of functors. In that respect, the correspondence between operads and monads follows from the relationship between the composition of symmetric sequences and the composition of functors (we refer to [159] for the introduction of this idea, to the book [60] for an overall account of operad theory based on this approach and further references).

This monadic approach of operads supposes that the tensor product of the base category commutes with colimits. But we soon consider categories for which this requirement and hence, the monadic approach, fail.

1.4. Appendix: filtered colimits and reflexive coequalizers

The existence of colimits in the category of operads, and in categories of algebras over an operad similarly, relies on the existence of particular colimits (filtered colimits and reflexive coequalizers), which we create in the base category. The purpose of this appendix section is to recall the definition of these fundamental colimits in a general context. We assume that \mathcal{C} is any category. In view towards applications to operads, we also study the image of filtered colimits and reflexive coequalizers under a multifunctor $T : \mathcal{C}^{\times r} \rightarrow \mathcal{C}$ with the example of r -fold tensor products $T(X_1, \dots, X_r) = X_1 \otimes \cdots \otimes X_r$ in mind.

1.4.1. *Filtered colimits.* Recall (see [122, §IX.1]) that a small category \mathcal{J} is filtering when:

- for any pair of objects $\alpha, \beta \in \mathcal{J}$, we have morphisms

$$\begin{array}{ccc} \alpha & \xrightarrow{u} & \gamma \\ & \searrow & \nearrow \\ & \beta & \end{array}$$

meeting at the same target object γ in \mathcal{J} ;

- for any pair of parallel morphisms $u, v : \alpha \rightrightarrows \beta$, we have a coequalizing morphism

$$\alpha \begin{array}{c} \xrightarrow{u} \\ \xrightarrow{v} \end{array} \beta \xrightarrow{t} \gamma$$

such that $tu = tv$ in \mathcal{J} .

We say that a colimit $\operatorname{colim}_{\alpha \in \mathcal{J}} X_\alpha$ is filtered when the indexing category \mathcal{J} of the diagram X_α is filtering.

We have the following observation:

PROPOSITION 1.4.2. *Suppose that the multifunctor $T : \mathcal{C}^{\times r} \rightarrow \mathcal{C}$ preserves filtered colimits on each input in the sense that the natural morphism*

$$\operatorname{colim}_{\alpha \in \mathcal{J}} T(X^1, \dots, X_\alpha^k, \dots, X^r) \rightarrow T(X^1, \dots, \operatorname{colim}_{\alpha \in \mathcal{J}} X_\alpha^k, \dots, X^r)$$

is iso for any diagram $\{X_\alpha^k\}_\alpha$ over a filtering category \mathcal{J} and all $X^i \in \mathcal{C}$, $i = 1, \dots, \widehat{k}, \dots, r$. Then the functor $T : \mathcal{C}^{\times r} \rightarrow \mathcal{C}$ preserves filtered colimits on the product category $\mathcal{C}^{\times r}$ in the sense that the natural morphism

$$\operatorname{colim}_{\alpha \in \mathcal{J}} T(X_\alpha^1, \dots, X_\alpha^r) \rightarrow T(\operatorname{colim}_{\alpha \in \mathcal{J}} X_\alpha^1, \dots, \operatorname{colim}_{\alpha \in \mathcal{J}} X_\alpha^r)$$

is iso for any collection of diagrams $\{X_\alpha^i\}_\alpha$, $i = 1, \dots, r$, over the same given filtering category \mathcal{J} .

PROOF. Exercise, or see [60, Proposition 1.2.2] or [148, Lemma 2.3.2]. \square

1.4.3. *Reflexive coequalizers.* Recall that a coequalizer is the colimit of a diagram formed by a parallel pair of morphisms $d_0, d_1 : X_1 \rightrightarrows X_0$. For a colimit of this particular shape, we use the notation $\operatorname{coker}\{d_0, d_1 : X_1 \rightrightarrows X_0\}$.

In many examples, a parallel pair of morphisms is given together with an extra morphism $s_0 : X_0 \rightarrow X_1$ satisfying $d_0 s_0 = id = d_1 s_0$. In this situation, we say that $\operatorname{coker}\{d_0, d_1 : X_1 \rightrightarrows X_0\}$ forms a reflexive coequalizer and we may also use the notation

$$\operatorname{coker}\{X_1 \overset{\widehat{\rightrightarrows}}{\rightrightarrows} X_0\}$$

in order to stress the existence of the reflection $s_0 : X_0 \rightarrow X_1$.

Note that the addition of the reflection $s_0 : X_0 \rightarrow X_1$ to the diagram $X_1 \rightrightarrows X_0$ does not change the colimit. The importance of reflexive coequalizers lies in the following stability assertion:

PROPOSITION 1.4.4. *Suppose that the multifunctor $T : \mathcal{C}^{\times r} \rightarrow \mathcal{C}$ preserves reflexive coequalizers on each input in the sense that the natural morphism*

$$\begin{aligned} \text{coker}\{T(X^1, \dots, X_1^k, \dots, X^r) \xrightarrow{\widehat{\rightrightarrows}} T(X^1, \dots, X_0^k, \dots, X^r)\} \\ \rightarrow T(X^1, \dots, \text{coker}\{X_1^k \xrightarrow{\widehat{\rightrightarrows}} X_0^k\}, \dots, X^r) \end{aligned}$$

is iso for any reflexive diagram $\{X_1^k \xrightarrow{\widehat{\rightrightarrows}} X_0^k\}$ and all $X^i \in \mathcal{C}$, $i = 1, \dots, \widehat{k}, \dots, n$. Then the functor $T : \mathcal{C}^{\times r} \rightarrow \mathcal{C}$ preserves reflexive coequalizers on the product category $\mathcal{C}^{\times r}$ in the sense that the natural morphism

$$\begin{aligned} \text{coker}\{T(X_1^1, \dots, X_1^r) \xrightarrow{\widehat{\rightrightarrows}} T(X_0^1, \dots, X_0^r)\} \\ \rightarrow T(\text{coker}\{X_1^1 \xrightarrow{\widehat{\rightrightarrows}} X_0^1\}, \dots, \text{coker}\{X_1^r \xrightarrow{\widehat{\rightrightarrows}} X_0^r\}) \end{aligned}$$

is iso for any collection of reflexive diagram $\{X_1^i \xrightarrow{\widehat{\rightrightarrows}} X_0^i\}$, $i = 1, \dots, r$, in the base category.

PROOF. Exercise or see [60, Proposition 1.2.1] or [148, Lemma 2.3.2]. \square

The fundamental role of reflexive coequalizers is also asserted by the following proposition:

PROPOSITION 1.4.5. *If coproducts and reflexive coequalizers exist in a category \mathcal{C} , then so does any kind of small colimit in \mathcal{C} .*

PROOF. Exercise. Check [27, §2] and [28, §4.3]. \square

This proposition is applied in §§1.2-1.3 in order to prove the existence of colimits (of any shape) in the category of operads and in categories of algebras over operads.

Operads in Symmetric Monoidal Categories

In the previous chapter §1, we have worked in the setting of a base category \mathcal{M} equipped with a tensor product $\otimes : \mathcal{M} \times \mathcal{M} \rightarrow \mathcal{M}$ preserving colimits on each side. The colimit assumption is required for the application of categorical constructions (like colimits, free objects) to operads (§§1.2-1.3), and is also implicitly used as soon as we deal with endomorphisms operads (see §1.1). On the other hand, the definition of an operad in §1.1.1 makes sense in any symmetric monoidal category, without assuming that the tensor product satisfies any other requirement than the fundamental unit, associativity and symmetry axioms §0.8(a-c).

The overall purpose of this second chapter is to examine the application of general symmetric monoidal category concepts to operads (regardless of any colimit requirement). In §2.1, we study the definition of operads in general symmetric monoidal categories, and the applications of symmetric monoidal category changes to operads. In §2.2, we study operads in counitary cocommutative coalgebras (our main example of an elaborate symmetric monoidal category). In general, we rather use the term of Hopf operad to refer to this category of operads.

In an appendix section §2.3, we review the definition of various notions of functors associated with symmetric monoidal categories.

Throughout this chapter, we deal with a generalization of the notion of commutative algebra and of the notion of cocommutative coalgebra in the setting of symmetric monoidal categories. We devote a preliminary section to a survey of this subject before tackling our main topics.

The ideas explained in this chapter are again not original, and our purpose is mainly to give a comprehensive and detailed account of concepts and constructions scattered over the literature. The definition of the notion of an operad in the axiomatic setting of symmetric monoidal categories was apparently first considered in a report of G. Kelly, now published in [98], in the case where the tensor product satisfies the colimit preservation requirement.

2.0. Commutative (co)algebras in symmetric monoidal categories

The main purpose of this zeroth section, as we just explained, is to make explicit the definition of the notion of a unitary commutative algebra and of the dual notion of a counitary cocommutative coalgebra in the setting of symmetric monoidal categories. We address the case of commutative algebras first.

We only deal with commutative structures for the moment. We can however extend our formalism to define general associative (non-commutative) algebra structures in our symmetric monoidal category setting. We will address this case later on, in §7, where we begin to consider non-commutative structures in multiple symmetric monoidal categories.

2.0.1. *Unitary commutative algebras in symmetric monoidal categories.* Let \mathcal{M} be any symmetric monoidal category. We define a unitary commutative algebra in \mathcal{M} as a structure formed by an object $A \in \mathcal{M}$, together with morphisms $\eta : \mathbb{1} \rightarrow A$ and $\mu : A \otimes A \rightarrow A$ which make the following diagrams commute:

$$\begin{array}{ccc}
 A \otimes \mathbb{1} & \xrightarrow{id \otimes \eta} & A \otimes A & \xleftarrow{\eta \otimes id} & \mathbb{1} \otimes A & , & & A \otimes A \otimes A & \xrightarrow{id \otimes \mu} & A \otimes A & , & & A \otimes A & \xrightarrow{(1\ 2)^*} & A \otimes A & . \\
 & \searrow \simeq & \downarrow \mu & \swarrow \simeq & & & & \mu \otimes id \downarrow & & \downarrow \mu & & & \downarrow \mu & & \downarrow \mu & \\
 & & A & & & & & A \otimes A & \xrightarrow{\mu} & A & & & A & & A &
 \end{array}$$

The morphism η , respectively μ , represents the unit, respectively the product, attached to this commutative algebra A . The diagrams express the unit, associativity and commutativity relations that govern the structure.

In the basic case, where \mathcal{M} is the category of sets $\mathcal{M} = \mathit{Set}$ (respectively, the category of modules $\mathcal{M} = \mathit{Mod}$ over a ground ring \mathbb{k}), we obviously retrieve the classical notion of a commutative monoid with unit (respectively, of a commutative \mathbb{k} -algebra with unit).

In general, we refer to a unitary commutative algebra by the notation of its underlying object in the ground category $A \in \mathcal{M}$, and we abusively assume that the unit morphism η and the product μ are part of the internal structure attached to this object A . We adopt the letter η (respectively, μ) as a generic notation for all unit (respectively, product) morphisms attached to a unitary commutative algebra structure. If we need to specify the algebra to which these morphisms are associated, then we simply set $\eta = \eta_A$ (respectively, $\mu = \mu_A$) to mark the object $A \in \mathcal{M}$ in the notation.

The unitary commutative algebras in \mathcal{M} form a category, which we denote by $\mathcal{M}\mathit{Com}_+$, or just by $\mathit{Com}_+ = \mathcal{M}\mathit{Com}_+$ when the monoidal category \mathcal{M} is fixed by the context. We precisely define a morphism of unitary commutative algebras $f : A \rightarrow B$ as a morphism of \mathcal{M} which makes the following diagrams commute:

$$\begin{array}{ccc}
 \mathbb{1} & \xrightarrow{=} & \mathbb{1} & , & & A \otimes A & \xrightarrow{f \otimes f} & B \otimes B & . \\
 \eta_A \downarrow & & \downarrow \eta_B & & & \mu_A \downarrow & & \downarrow \mu_B & \\
 A & \xrightarrow{f} & B & & & A & \xrightarrow{f} & B &
 \end{array}$$

Recall that we use the lower script $+$ to mark the consideration of unitary structures (as in §1.1.16). The category of non-unitary commutative algebras, which we denote by $\mathcal{M}\mathit{Com}$ (or just by $\mathit{Com} = \mathcal{M}\mathit{Com}$), is obviously defined by dropping the reference to unit morphisms in all definitions.

Note that the unit object of the underlying category $\mathbb{1}$ inherits a natural commutative algebra structure, and represents the initial object of the category of unitary commutative algebras $\mathcal{M}\mathit{Com}_+$. One can prove that the obvious forgetful functor $\omega : \mathcal{M}\mathit{Com}_+ \rightarrow \mathcal{M}$ creates limits in unitary commutative algebras, whenever limits exist in \mathcal{M} . But the forgetful functor $\omega : \mathcal{M}\mathit{Com}_+ \rightarrow \mathcal{M}$ does not preserve colimits in general. (To give the simplest example, we have already observed that the unit object $\mathbb{1}$, which generally differs from the initial object of \mathcal{M} , is the initial object of $\mathcal{M}\mathit{Com}_+$.) In the case where the tensor product of \mathcal{M} satisfies the colimit preservation requirement of §0.9, one can prove that some particular colimits can be created in the ground category \mathcal{M} , and that $\mathcal{M}\mathit{Com}_+$ inherits colimits of any

shape. Indeed, this statement is a particular case of the general result which we establish in the framework of algebras over operads in §1.3. In the general case, where we do not assume any colimit requirement on the tensor structure, we still have coproducts in $\mathcal{M}Com_+$, which we deduce from the tensor product operation of the ground category. We explain this observation in the next paragraph.

2.0.2. *The symmetric monoidal category of unitary commutative algebras.* The category of unitary commutative algebras in a symmetric monoidal category $\mathcal{M}Com_+$ actually inherits a symmetric monoidal structure from the ground category \mathcal{M} .

First, we readily see that a tensor product of commutative algebras $A \otimes B$ inherits a canonical unit morphism $\mathbb{1} \xrightarrow{\simeq} \mathbb{1} \otimes \mathbb{1} \xrightarrow{\eta_A \otimes \eta_B} A \otimes B$, and a canonical product, defined by the composite $A \otimes B \otimes A \otimes B \xrightarrow{(2\ 3)^*} A \otimes A \otimes B \otimes B \xrightarrow{\mu \otimes \mu} A \otimes B$, so that $A \otimes B$ forms a commutative algebra.

For the unit object $\mathbb{1}$, which represents the initial object of the category of commutative algebras $\mathcal{M}Com_+$, the isomorphisms $A \otimes \mathbb{1} \xrightarrow{\simeq} A \xleftarrow{\simeq} \mathbb{1} \otimes A$, formed in the underlying monoidal category \mathcal{M} , are isomorphisms of unitary commutative algebras. Hence, the unit relations of the tensor product hold within the category $\mathcal{M}Com_+$. The associativity and symmetry relations of the tensor product remain valid in the category of unitary commutative algebras too. Thus, we have a whole symmetric monoidal structure on $\mathcal{M}Com_+$, as claimed at the beginning of this paragraph.

We readily see moreover that the tensor product $A \otimes B$ represents the coproduct of A and B in Com_+ (and therefore coproducts exist in Com_+ without any assumption on the tensor product). The universal morphisms $A \xrightarrow{i} A \otimes B \xleftarrow{j} B$ are given by the tensor products $i = id_A \otimes \eta_B$ and $j = \eta_A \otimes id_B$, where we consider the unit morphism $\eta_A : \mathbb{1} \rightarrow A$ (respectively, $\eta_B : \mathbb{1} \rightarrow B$) associated to A (respectively, B).

2.0.3. *Counitary cocommutative coalgebras in symmetric monoidal categories.* The structure of a counitary cocommutative coalgebra in a symmetric monoidal category is defined by duality from the definition of a unitary commutative algebra.

In brief, a counitary cocommutative coalgebra in \mathcal{M} consists of an object $C \in \mathcal{M}$, equipped with morphisms $\epsilon : C \rightarrow \mathbb{1}$ and $\Delta : C \rightarrow C \otimes C$ such that the following diagrams commute:

$$\begin{array}{ccc}
 & C & \\
 \simeq \swarrow & & \searrow \simeq \\
 C \otimes \mathbb{1} & \xleftarrow{id \otimes \epsilon} & C \otimes C & \xrightarrow{\epsilon \otimes id} & \mathbb{1} \otimes C
 \end{array}
 , \quad
 \begin{array}{ccc}
 C & \xrightarrow{\Delta} & C \otimes C \\
 \Delta \downarrow & & \downarrow \Delta \otimes id \\
 C \otimes C & \xrightarrow{id \otimes \Delta} & C \otimes C \otimes C
 \end{array}
 , \quad
 \begin{array}{ccc}
 & C & \\
 \Delta \swarrow & & \searrow \Delta \\
 C \otimes C & \xrightarrow{(1\ 2)^*} & C \otimes C
 \end{array}
 .$$

The morphism ϵ (respectively, Δ) is called the counit or augmentation (respectively, the coproduct or diagonal) of the cocommutative algebra C . The diagrams express the unit, associativity and commutativity relations that govern this structure.

We refer to a counitary cocommutative coalgebra by the notation of its underlying object $C \in \mathcal{M}$ (as in the algebra case). We use the letter ϵ (respectively, Δ) as a generic notation for all counit (respectively, coproduct) morphisms attached to a counitary cocommutative coalgebra structure. We just mark the object $A \in \mathcal{M}$ as a subscript when we need to specify the coalgebra to which these morphisms are attached in the notation.

The counitary cocommutative coalgebras in \mathcal{M} form a category, which we denote by $\mathcal{M}\mathcal{C}om_+^c$, or just by $\mathcal{C}om_+^c = \mathcal{M}\mathcal{C}om_+^c$, with the superscript c added to notation in order to mark the consideration of coalgebras. We precisely define a morphism of counitary cocommutative coalgebras $f : C \rightarrow D$ as a morphism of \mathcal{M} which makes the following diagrams commute

$$\begin{array}{ccc} C & \xrightarrow{f} & D \\ \epsilon_C \downarrow & & \downarrow \epsilon_D \\ \mathbb{1} & \xrightarrow{=} & \mathbb{1} \end{array}, \quad \begin{array}{ccc} C & \xrightarrow{f} & D \\ \Delta_C \downarrow & & \downarrow \Delta_D \\ C \otimes C & \xrightarrow{f \otimes f} & D \otimes D \end{array},$$

The basic notion of counitary cocommutative coalgebra, classically considered in the literature, corresponds to the case where $\mathcal{M} = \mathcal{M}od$ is a category of modules over a ground ring k . In the case where \mathcal{M} is the category of sets $\mathcal{M} = \mathcal{S}et$ (and more generally when the tensor structure is given by the cartesian structure of the category), any object $X \in \mathcal{S}et$ inherits a counit $\epsilon : X \rightarrow *$, because the unit object is the final object $*$ (the one-point set when $\mathcal{M} = \mathcal{S}et$), as well as a coproduct $\Delta : X \rightarrow X \times X$ (the diagonal). Our counit, coassociativity and cocommutativity relations obviously hold for this structure. Hence, any $X \in \mathcal{S}et$ inherits a tautological counitary cocommutative coalgebra structure. The definition of the coproduct on X is actually forced by the counit relation, and as a consequence, we have an isomorphism of categories $\mathcal{S}et\mathcal{C}om_+^c = \mathcal{S}et$.

The tensor unit $\mathbb{1}$ inherits a coalgebra structure, defined by inverting the orientation of the arrows in the definition of the algebra structure of §2.0.1, and represents the terminal object of the category of counitary cocommutative coalgebras. Besides, we can also dualize the construction of the tensor product of algebras in §2.0.2 to obtain that a tensor product of counitary cocommutative coalgebras $C \otimes D$ inherits a counitary cocommutative coalgebra structure, with the composite morphism $C \otimes D \xrightarrow{\epsilon_C \otimes \epsilon_D} \mathbb{1} \otimes \mathbb{1} \xrightarrow{\cong} \mathbb{1}$ as counit, and the morphism $C \otimes D \xrightarrow{\Delta_C \otimes \Delta_D} C \otimes C \otimes D \otimes D \xrightarrow{(2\ 3)^*} C \otimes D \otimes C \otimes D$ as coproduct.

This tensor product $C \otimes D$ also represents the cartesian product of C and D in the category of counitary cocommutative coalgebras. The universal morphisms $C \xleftarrow{p} C \otimes D \xrightarrow{q} D$ are given by the tensor products $p = id \otimes \epsilon_D$ and $q = \epsilon_C \otimes id$, where we consider the counit $\epsilon_C : C \rightarrow \mathbb{1}$ (respectively, $\epsilon_D : D \rightarrow \mathbb{1}$) of C (respectively, D).

The previous assertion is the exact dual of an observation of §2.0.2 on the tensor product of unitary commutative algebras. One can also check that the forgetful functor $\omega : \mathcal{M}\mathcal{C}om_+^c \rightarrow \mathcal{M}$ creates colimits whenever colimits exist in \mathcal{M} , just like the dual forgetful functor on the category of commutative algebras creates limits. But, we can not dualize the construction of general colimits in the category of unitary commutative algebras to get limits in the category of counitary cocommutative coalgebras, because we should require that tensor products preserve limits (instead of colimits) then, and this assumption is not fulfilled in general.

We can also use the tensor product construction to provide the category of counitary cocommutative coalgebras with a symmetric monoidal structure, as in the dual context of unitary commutative algebras.

2.0.4. *Change of underlying symmetric monoidal categories.* To complete this preliminary section, we examine the application of a change of symmetric monoidal category to algebra and coalgebra structures.

First, we consider the case where we have a unit-pointed functor $S : \mathcal{M} \rightarrow \mathcal{N}$ between symmetric monoidal categories \mathcal{M} and \mathcal{N} together with a symmetric monoidal transformation $\theta : S(X) \otimes S(Y) \rightarrow S(X \otimes Y)$ (see §2.3.1). Let A be a unitary commutative algebra in a symmetric monoidal category \mathcal{M} . Then the object $S(A) \in \mathcal{N}$ forms a commutative algebra in \mathcal{N} . Indeed, we have a unit morphism

$$\mathbb{1} \xrightarrow{=} S(\mathbb{1}) \xrightarrow{S(\eta)} S(A)$$

as well as a product

$$S(A) \otimes S(A) \xrightarrow{\theta} S(A \otimes A) \xrightarrow{S(\mu)} S(A),$$

inherited from A , and which satisfy the unit, associativity, and commutativity axioms of §2.0.1 as soon as the natural transformation θ fulfills the coherence constraints of §2.3.1 with respect to the internal symmetric monoidal structures of our categories (easy verification).

This construction is obviously functorial with respect to the commutative algebra A . Hence, the mapping $S : A \mapsto S(A)$ induces a functor from the category of unitary commutative algebras in \mathcal{M} towards the category of unitary commutative algebras in \mathcal{N} . This functor $S : \mathcal{M}\mathcal{C}om_+ \rightarrow \mathcal{N}\mathcal{C}om_+$ is unit-pointed, and we readily see, moreover, that the symmetric monoidal transformation $\theta : S(A) \otimes S(B) \rightarrow S(A \otimes B)$, inherited from S , defines a morphism of unitary commutative algebras when $A, B \in \mathcal{M}\mathcal{C}om_+$. Thus, the functor $S : \mathcal{M}\mathcal{C}om_+ \rightarrow \mathcal{N}\mathcal{C}om_+$ induced by $S : \mathcal{M} \rightarrow \mathcal{N}$ is unit-pointed and comes also equipped with a symmetric monoidal transformation in the category of unitary commutative algebras in \mathcal{N} .

In the dual case where $S : \mathcal{M} \rightarrow \mathcal{N}$ is a unit-pointed functor equipped with a symmetric comonoidal transformation $\theta : S(X \otimes Y) \rightarrow S(X) \otimes S(Y)$, we readily see that the image of a unitary cocommutative coalgebra under S inherits a unitary cocommutative coalgebra structure so that S induces a functor from the category of counitary cocommutative coalgebras in \mathcal{M} towards the category of counitary cocommutative coalgebras in \mathcal{N} . This functor $S : \mathcal{M}\mathcal{C}om_+^c \rightarrow \mathcal{N}\mathcal{C}om_+^c$, induced by $S : \mathcal{M} \rightarrow \mathcal{N}$, is unit-pointed and comes also equipped with a symmetric comonoidal transformation in the category of counitary cocommutative algebras, which is yielded by the symmetric comonoidal transformation associated to S in \mathcal{N} .

In the optimal situation where our functor $S : \mathcal{M} \rightarrow \mathcal{N}$ is symmetric monoidal (see §2.3.1), we have a functor induced by S both on algebras $S : \mathcal{M}\mathcal{C}om_+ \rightarrow \mathcal{N}\mathcal{C}om_+$ and on coalgebras $S : \mathcal{M}\mathcal{C}om_+^c \rightarrow \mathcal{N}\mathcal{C}om_+^c$. These functors are both symmetric monoidal too.

In the case where we have functors $S : \mathcal{M} \rightleftarrows \mathcal{N} : T$ forming a symmetric monoidal adjunction in the sense of §2.3.3, we have an induced a symmetric monoidal adjunction at the level of algebra categories $S : \mathcal{M}\mathcal{C}om_+ \rightarrow \mathcal{N}\mathcal{C}om_+ : T$, and at the level of coalgebra categories $S : \mathcal{M}\mathcal{C}om_+^c \rightarrow \mathcal{N}\mathcal{C}om_+^c : T$ as well. Indeed, we readily see that the unit $\eta : X \rightarrow T(S(X))$ and the augmentation $\epsilon : T(S(A)) \rightarrow A$ of such an adjunction define morphisms of unitary commutative algebras (respectively, counitary cocommutative coalgebras) when X (respectively, A) has such a structure, and therefore, define the unit and the augmentation morphism of an adjunction at the algebra (respectively, coalgebra) level.

2.0.5. *The basic example of free module functors.* To give a simple example of symmetric monoidal category change, we consider functor $\mathbb{k}[-] : \mathit{Set} \rightarrow \mathit{Mod}$, which maps any set $X \in \mathit{Set}$ to a free \mathbb{k} -module generated by the elements of the set X , for a fixed ground ring \mathbb{k} . We generally write $[x]$ for the generating element of the \mathbb{k} -module $\mathbb{k}[X]$ associated to an element $x \in X$.

This functor $\mathbb{k}[-] : \mathit{Set} \rightarrow \mathit{Mod}$ is symmetric monoidal (see §2.3.2), and hence, induces both a symmetric monoidal functor from unitary commutative monoids (unitary commutative algebras in sets) to unitary commutative algebras, and from sets to counitary commutative algebras, where we use the observation of §2.0.3 to get a category isomorphism $\mathit{Set} = \mathit{Set} \mathit{Com}_+^c$ identifying the category of counitary commutative algebras in sets with the category of sets themselves.

We consider this functor from sets to counitary cocommutative coalgebras $\mathbb{k}[-] : \mathit{Set} \rightarrow \mathit{Mod} \mathit{Com}_+^c$. We set $\mathit{Com}_+^c = \mathit{Mod} \mathit{Com}_+^c$ to abbreviate notation.

The counit and coproduct defining the counitary cocommutative coalgebra structure of a free \mathbb{k} -module $\mathbb{k}[X]$ can be defined by the explicit formula $\epsilon[x] = 1$ and $\Delta[x] = [x] \otimes [x]$ for each element $x \in X$.

In general, we say that an element $c \in C$ in a counitary cocommutative coalgebra in \mathbb{k} -modules C is group-like when we have $\epsilon(c) = 1$ and $\Delta(c) = c \otimes c$ in C , and we use the notation $\mathbb{G}(C)$ for the set formed by the group-like elements in C . We can easily check that the mapping $\mathbb{G} : C \mapsto \mathbb{G}(C)$ defines a right-adjoint of our functor $\mathbb{k}[-] : \mathit{Set} \rightarrow \mathit{Com}_+^c$, from sets to counitary cocommutative coalgebras. The unit of this adjunction is the obvious set embedding $\iota : X \rightarrow \mathbb{k}[X]$, and the augmentation $\rho : \mathbb{k}[\mathbb{G}(C)] \rightarrow C$ is identified with the obvious \mathbb{k} -module morphism induced by the tautological set-theoretic inclusion $\mathbb{G}(C) \subset C$.

We deduce from the general observations of §2.0.4 that the functor $\mathbb{k}[-] : \mathit{Set} \rightarrow \mathit{Com}_+^c$ is symmetric monoidal, since our initial functor $\mathbb{k}[-] : \mathit{Set} \rightarrow \mathit{Mod}$, from sets to \mathbb{k} -modules, is so. We immediately see that the group-like functor $\mathbb{G} : \mathit{Com}_+^c \rightarrow \mathit{Set}$ is symmetric monoidal too, because this functor, as a right-adjoint, preserves final objects and cartesian products, with which the unit and tensor product of the symmetric monoidal structure of coalgebras are identified (see §2.0.3). We can easily check that the unit morphism and the augmentation morphism of the adjunction $\mathbb{k}[-] : \mathit{Set} \rightleftarrows \mathit{Com}_+^c : \mathbb{G}$ are also symmetric monoidal transformations, so that our adjoint functors define a symmetric monoidal adjunction in the sense of §2.3.3.

2.1. The definition of operads in symmetric monoidal categories

The purpose of this section is to examine the application of general symmetric monoidal category constructions to operads.

In §1.1, we assume that the base category \mathcal{M} has a tensor product $\otimes : \mathcal{M} \times \mathcal{M} \rightarrow \mathcal{M}$ which preserves colimits on each side. Nevertheless, we have already observed that the definition of an operad in §1.1.1 makes sense as soon as the unit, associativity and symmetry axioms of symmetric monoidal categories are satisfied. This is also the case of the definition of an algebra over an operad in §1.1.13 though the statement of Proposition 1.1.15, giving an interpretation of operad actions in terms of endomorphism operads, is not valid in general.

We first give the definition of an operad governing general commutative algebra structures. Our statements extend the results of Proposition 1.1.10 and Proposition 1.1.18:

PROPOSITION 2.1.1. *In any symmetric monoidal category \mathcal{M} , we can form an operad \mathbf{Com}_+ such that $\mathbf{Com}_+(r) = \mathbb{1}$ for every $r \in \mathbb{N}$, where $\mathbb{1}$ refers to the unit object of \mathcal{M} .*

The structure of this operad is precisely defined as follows: each component of the operad $\mathbf{Com}_+(r) = \mathbb{1}$ is equipped with a trivial action of the corresponding symmetric group Σ_r , the unit morphism $\eta : \mathbb{1} \rightarrow \mathbf{Com}_+(1)$ is the identity of $\mathbb{1}$, and the composition products $\mu : \mathbf{Com}_+(r) \otimes \mathbf{Com}_+(n_1) \otimes \cdots \otimes \mathbf{Com}_+(n_r) \rightarrow \mathbf{Com}_+(n_1 + \cdots + n_r)$ are given by the canonical isomorphisms $\mathbb{1} \otimes \mathbb{1} \otimes \cdots \otimes \mathbb{1} \xrightarrow{\cong} \mathbb{1}$.

The collection \mathbf{Com} such that $\mathbf{Com}(0) = \emptyset$ and $\mathbf{Com}(r) = \mathbb{1}$ for $r > 0$ inherits an operad structure as well, and is actually a sub-object of \mathbf{Com}_+ in the category of operads.

PROOF. The equivariance, unit, and associativity relations of the operadic composition structure of \mathbf{Com}_+ follow from the internal coherence relations satisfied by the unit, associativity, and symmetry isomorphisms in symmetric monoidal categories.

We define the composition products of the operad \mathbf{Com} by restriction from the composition structure of \mathbf{Com}_+ , and for this purpose, we essentially have to check that the composite $\mathbb{1} \otimes \emptyset \otimes \cdots \otimes \emptyset \rightarrow \mathbb{1} \otimes \mathbb{1} \otimes \cdots \otimes \mathbb{1} \rightarrow \mathbb{1}$ factors through $\mathbf{Com}(0) = \emptyset$ when we deal with a composition product of the form $\mathbf{Com}(r) \otimes \mathbf{Com}(0) \otimes \cdots \otimes \mathbf{Com}(0) \rightarrow \mathbf{Com}(0)$. But this assertion is just a direct consequence of the functoriality of the unit isomorphism $\mathbb{1} \otimes X \simeq X$. \square

PROPOSITION 2.1.2. *Let \mathcal{M} be any symmetric monoidal category. The category of unitary commutative algebras in \mathcal{M} , as defined in §2.0.1, is isomorphic to the category of algebras over the operad \mathbf{Com}_+ of Proposition 2.1.1. The category of non-unitary commutative algebras in \mathcal{M} is isomorphic to the category of algebras over the non-unitary operad \mathbf{Com} formed by dropping the term of arity 0 in \mathbf{Com}_+ .*

PROOF. The result of this proposition concerning the categories of commutative algebras in \mathcal{M} follows from a formal extension, in the setting of monoidal categories, of the arguments of Proposition 1.1.17-1.1.18. \square

In the case $\mathcal{M} = \mathbf{Set}$, where we have $\mathbb{1} = pt$, we exactly retrieve the result of Proposition 1.1.18, where the category of commutative monoids with unit is identified with the category of algebras over the one-point set operad. Indeed, the operad defined in the proposition is a generalization of the one-point set operad of Proposition 1.1.10, and our construction gives a version of the unitary commutative operad \mathbf{Com}_+ attached to any symmetric monoidal category \mathcal{M} .

The second basic example of application of Proposition 1.1.18 is the category of \mathbb{k} -modules $\mathcal{M} = \mathbf{Mod}$. In this case, we obtain that the usual category of unitary commutative algebras over \mathbb{k} is isomorphic to the category of algebras over the operad \mathbf{Com}_+ such that $\mathbf{Com}_+(r) = \mathbb{k}$ for every $r \in \mathbb{N}$, and similarly in the non-unitary setting.

In the situation where the ground symmetric monoidal category \mathcal{M} has colimits and the tensor product preserves colimits, we can extend the presentation by generators and relations of §1.2.10, to define an operad in \mathcal{M} governing unitary (respectively, non-unitary) commutative algebra structures. We can easily check that this definition by generators and relations, whenever it makes sense, returns the same operad as the direct construction of Proposition 2.1.1 (adapt the argument

line of Proposition 1.2.7). We therefore have an equivalence between this approach and the general definition of Proposition 2.1.1.

To continue this study, we examine the application of a change of underlying symmetric monoidal category to operads. We consider a functor $S : \mathcal{M} \rightarrow \mathcal{N}$ between symmetric monoidal categories \mathcal{M} and \mathcal{N} . Recall that S is said to be unit-pointed when we have $S(\mathbb{1}) = \mathbb{1}$, and we say that a unit-pointed functor S is equipped with a symmetric monoidal transformation if we have a bifunctor morphism $\theta : S(A) \otimes S(B) \rightarrow S(A \otimes B)$, $A, B \in \mathcal{M}$, satisfying natural unit, associativity, and symmetry constraints (see §2.3.1 for details). We have the following result:

LEMMA 2.1.3. *Let P be an operad in \mathcal{M} . If $S : \mathcal{M} \rightarrow \mathcal{N}$ is a unit-pointed functor equipped with a symmetric monoidal transformation $\theta : S(A) \otimes S(B) \rightarrow S(A \otimes B)$, then the collection of objects $S(P(r)) \in \mathcal{N}$, $r \in \mathbb{N}$, defined by applying S termwise to the underlying collection of P , forms an operad $S(P)$ in \mathcal{N} . Indeed:*

- (a) *The functor S maps the morphisms $s : P(r) \rightarrow P(r)$ giving the action of permutations $s \in \Sigma_r$ on $P(r)$ to morphisms of the category \mathcal{N} , so that the object $S(P(r)) \in \mathcal{N}$ inherits an action of the symmetric group Σ_r , and this for all $r \in \mathbb{N}$.*
- (b) *The collection $S(P)(r) = S(P(r))$ also inherits a unit morphism*

$$\mathbb{1} \xrightarrow{\cong} S(\mathbb{1}) \xrightarrow{S(\eta)} S(P(1))$$

as well as composition products

$$S(P(r)) \otimes S(P(n_1)) \otimes \cdots \otimes S(P(n_r)) \xrightarrow{\theta} S(P(r) \otimes P(n_1) \otimes \cdots \otimes P(n_r)) \xrightarrow{S(\mu)} S(P(n_1 + \cdots + n_r)),$$

and the equivariance, unit and associativity relations of operads (§1.1.1) hold for this operadic composition structure.

PROOF. The unit, associativity and symmetry constraints of symmetric monoidal transformations (§2.3.1) imply that the equivariance, unit and associativity relations of operads on $S(P)$ reduce to the corresponding relations on P , and hence hold at the level of that collection $S(P)$. \square

The construction of the operad structure in this lemma is clearly functorial in $P \in \mathcal{MOp}$. Furthermore, for a unitary operad P_+ (in the sense of §1.1.19), we have $S(P_+(0)) = S(\mathbb{1}) = \mathbb{1}$, so that $S(P_+)$ is still unitary with $S(P)$ as associated non-unitary operad (see §1.1.20). Finally, we have the following proposition:

PROPOSITION 2.1.4. *If $S : \mathcal{M} \rightarrow \mathcal{N}$ is a unit-pointed functor equipped with a symmetric monoidal transformation, then S induces a functor on operad categories $S : \mathcal{MOp} \rightarrow \mathcal{NOp}$. This functor is given by the construction of Lemma 2.1.3 on objects $P \in \mathcal{MOp}$.*

This functor also preserves unitary extensions (in the sense of §1.1.20), since we have the identity $S(P_+) = S(P)_+$, for any unitary operad $P_+ \in \mathcal{MOp}_1$. \square

In our applications, we essentially need to transport operads from one symmetric monoidal category to another, and we base our constructions on the previous proposition. For the sake of completeness, we can also record that the functor $S : \mathcal{M} \rightarrow \mathcal{N}$ in Proposition 2.1.4 induces a functor from the category of algebras over $P \in \mathcal{MOp}$ to the category of algebras over the operad $S(P) \in \mathcal{NOp}$ associated

to P in \mathcal{N} . To check this assertion, simply observe that the image of a P -algebra under S inherits evaluation morphisms $S(P(r)) \otimes S(A)^{\otimes r} \rightarrow S(P(r) \otimes A^{\otimes r}) \rightarrow S(A)$ providing $S(A)$ with a natural $S(P)$ -algebra structure.

2.1.5. *Examples of functors between operad categories.* The functors considered in §2.3.2 give examples of situations where we can use the result of Proposition 2.1.4.

- (a) Let us begin with the simplest example, namely the functor $\mathbb{k}[-] : \mathcal{S}et \rightarrow \mathcal{M}od$ mapping a set $X \in \mathcal{S}et$ to the associated free \mathbb{k} -module $\mathbb{k}[X] \in \mathcal{M}od$. Proposition 2.1.4 implies that this functor induces a functor $\mathbb{k}[-] : \mathcal{S}etOp \rightarrow \mathcal{M}odOp$, from the category of operads in sets towards the category of operads in \mathbb{k} -modules, and similarly as regards the extension of this functor to simplicial sets $\mathbb{k}[-] : \mathcal{S}imp \rightarrow s\mathcal{M}od$.
- (b) The geometric realization functor $|-| : \mathcal{S}imp \rightarrow \mathcal{T}op$ induces a functor $\mathbb{k}[-] : \mathcal{S}impOp \rightarrow \mathcal{T}opOp$, from the category of operads in simplicial sets towards the category of topological operads. In the converse direction, the singular complex functor $\mathbf{Sing}_\bullet(-) : \mathcal{T}op \rightarrow \mathcal{S}imp$ induces a functor $\mathbf{Sing}_\bullet(-) : \mathcal{T}opOp \rightarrow \mathcal{S}impOp$, from the category of topological operads towards the category of operads in simplicial sets.

Recall that the geometric realization and singular complex functors define an instance of symmetric monoidal adjunction. In such a situation, we have the following additional result:

PROPOSITION 2.1.6. *The functors on operad categories $S : \mathcal{M}Op \rightleftharpoons \mathcal{N}Op : T$ induced by the functors of a symmetric monoidal adjunction $S : \mathcal{M} \rightleftharpoons \mathcal{N} : T$ are still adjoint to each other. The augmentation $\epsilon : S(T(Q)) \rightarrow Q$ and the unit $\eta : P \rightarrow T(S(P))$ of this adjunction (at the operad level) are given by the arity-wise application of the augmentation and unit of the underlying adjunction between the categories \mathcal{M} and \mathcal{N} .*

PROOF. The augmentation $\epsilon : S(T(Y)) \rightarrow Y$ and the unit $\eta : X \rightarrow T(S(X))$, of the adjunction $S : \mathcal{M} \rightleftharpoons \mathcal{N} : T$ are symmetric monoidal transformations by definition of the notion of a symmetric monoidal adjunction. This observation immediately implies that these morphisms can be applied arity-wise to operads in order to yield morphisms at the operad category level. The structure relations between adjunction augmentations and adjunction units remain obviously valid for these induced operad morphisms, and therefore, we still have an adjunction relation at the level of operad categories, with the unit and augmentation morphisms specified in the proposition. \square

Let us record the application of this result to the geometric realization and singular complex functors into a proposition:

PROPOSITION 2.1.7. *The functors on operad categories $|-| : \mathcal{S}impOp \rightleftharpoons \mathcal{T}opOp : \mathbf{Sing}_\bullet(-)$ induced by the realization of simplicial sets and by the singular complex functor are adjoint to each other. The augmentation $\epsilon : |-| \mathbf{Sing}_\bullet(Q) \rightarrow Q$, respectively the unit $\eta : P \rightarrow \mathbf{Sing}_\bullet(|P|)$, of this adjunction is given by the arity-wise application of the augmentation, respectively unit, of the underlying adjunction between simplicial sets and topological spaces.*

Further examples of applications of Proposition 2.1.4-2.1.6 are studied all throughout this work. For instance, the result of Proposition 2.1.6 applies the adjunction $\mathbb{k}[-] : \mathcal{S}et \rightarrow \mathcal{C}om_+^c : \mathbb{G}$, between sets and counitary cocommutative coalgebras, involving the extension of the functor $\mathbb{k}[-] : \mathcal{S}et \rightarrow \mathcal{M}od$ to coalgebras as left adjoint (see §2.0.5).

In the sequel, we often face adjunction relations $F : \mathcal{M} \rightleftarrows \mathcal{N} : G$ such that the right adjoint functor G is symmetric monoidal, but not the left adjoint F (or conversely). In this situation, we still have a functor $G : \mathcal{N}Op \rightarrow \mathcal{M}Op$, but we can not apply Proposition 2.1.4 to get a functor on operads from F . On the other hand, we will see that the functor $G : \mathcal{N}Op \rightarrow \mathcal{M}Op$, obtained by the arity-wise application of $G : \mathcal{N} \rightarrow \mathcal{M}$, preserves limits. In practice, we can apply adjoint functor theorems to retrieve an adjunction relation on operad categories from the single functor $G : \mathcal{N}Op \rightarrow \mathcal{M}Op$, and we obtain that way an operadic replacement $F_{\#} : \mathcal{M}Op \rightarrow \mathcal{N}Op$ of the functor $F : \mathcal{M} \rightarrow \mathcal{N}$. In §5, we use this approach to produce a Sullivan's model functor from operads in simplicial sets to cooperads in cosimplicial commutative algebras (the structures dual to operads in simplicial cocommutative coalgebras).

To prepare this subsequent study, we will examine the definition of an operad in cocommutative coalgebras in details in the next section.

Before tackling this new subject, simply observe that we can apply the functor $\mathbb{k}[-] : \mathcal{S}etOp \rightarrow \mathcal{M}odOp$ of §2.1.5(a) to the permutation (respectively, one-point set) operad of §1.1 in order to obtain a model of the associative (respectively, commutative) operad in \mathbb{k} -modules. In the case of the permutation operad, we obtain an operad such that $\mathcal{A}s_+(r) = \mathbb{k}[\Sigma_r]$ for $r \in \mathbb{N}$ (unitary case). In the case of the one-point set operad, we obtain an operad such that $\mathcal{C}om_+(r) = \mathbb{k}[pt] = \mathbb{k}$ for $r \in \mathbb{N}$. In the non-unitary setting, we simply replace the arity 0 component of these operads by the null module. In any case, we exactly retrieve the expansion of §§1.2.10-1.2.11 for the operads defined by generators and relations in §1.2.10. This identification gives an analogue of the results of Proposition 1.2.7 in the context of \mathbb{k} -modules. Note that $\mathcal{C}om_+(r) = \mathbb{k}$ can also be identified with a particular instance of the commutative operad of Proposition 2.1.1-2.1.2 since \mathbb{k} represents the unit object of the category of \mathbb{k} -modules.

2.2. The notion of a Hopf operad

We now study the structure defined by an operad in counitary cocommutative coalgebras. One of our aims is to check that operads in counitary cocommutative coalgebras are actually equivalent to counitary cocommutative coalgebra objects in the category of operads. The existence of these multiple equivalent definitions motivates us to adopt specific conventions for these operads.

We generally use the terminology of Hopf operad, rather than the expression of operad in counitary cocommutative coalgebras, to refer to these objects, unless we want to emphasize a particular definition of our structure. We also use the notation $\mathcal{H}opfOp$, rather than $\mathcal{C}om_+^cOp$, to refer to the category of Hopf operads.

We use the name Hopf as a general prefix to specify a category of structured object in counitary and cocommutative coalgebras, or dually, a category of costructured object in unitary and commutative algebras. We stress that the coalgebra (respectively, algebra) structure underlying a Hopf object is, under our convention, supposed to be cocommutative in general. When we use the expression of Hopf

operad, we therefore consider operads equipped with a counitary cocommutative coalgebra structure.

The constructions of the next paragraphs §§2.2.1-2.2.5 are valid in an arbitrary ambient symmetric monoidal category \mathcal{M} , which we fix up to the end of this section.

2.2.1. *The definition of Hopf operads as operads in counitary cocommutative coalgebras.* The symmetric monoidal structure of the category of counitary cocommutative coalgebras $\mathcal{C}om_+^c = \mathcal{M}Com_+^c$ is defined in §2.0.3. Recall simply that the tensor product of coalgebras $A, B \in \mathcal{C}om_+^c$ is obtained by providing the tensor product of A and B in the underlying symmetric monoidal category with a natural coalgebra structure. The unit, associativity, and symmetry isomorphisms of the tensor product of coalgebras are inherited from the ambient symmetric monoidal category, and the forgetful functor $\omega : \mathcal{M}Com_+^c \rightarrow \mathcal{M}$ is, as a consequence, symmetric monoidal in the sense of §2.3.1.

To define operads in counitary cocommutative coalgebras, we simply apply the general definition of §1.1.1 to the symmetric monoidal category of coalgebras $\mathcal{C}om_+^c$. Under this approach, an operad in counitary cocommutative coalgebras (a Hopf operad in our synonymous terminology) consists of a collection of counitary cocommutative coalgebras $P(r)$, together with an action of the symmetric group Σ_r on $P(r)$, for each $r \in \mathbb{N}$, a unit morphism $\eta : \mathbb{1} \rightarrow P(1)$, and product morphisms $\mu : P(r) \otimes P(n_1) \otimes \cdots \otimes P(n_r) \rightarrow P(n_1 + \cdots + n_r)$, all formed within the category of counitary cocommutative coalgebras and satisfying the equivariance, unit, and associativity relations of §1.1.1 in that category $\mathcal{C}om_+^c$.

2.2.2. *The internal structure of Hopf operads.* An operad in counitary cocommutative coalgebras forms an operad in the ground category since, as we just observed, the forgetful functor $\omega : \mathcal{M}Com_+^c \rightarrow \mathcal{M}$ is symmetric monoidal by construction. As such, an operad in counitary cocommutative coalgebras P can be identified with an operad in \mathcal{M} so that the symmetric group Σ_r acts on $P(r)$ by morphisms of cocommutative coalgebras, for each $r \in \mathbb{N}$, and the unit morphism $\eta : \mathbb{1} \rightarrow P(1)$ preserves coalgebra structures, as well as the product morphisms $\mu : P(r) \otimes P(n_1) \otimes \cdots \otimes P(n_r) \rightarrow P(n_1 + \cdots + n_r)$. Accordingly, to completely unravel the definition, we simply need to go back to the definition of the coalgebra structure on the unit object $\mathbb{1}$, and on the tensor product $P(r) \otimes P(n_1) \otimes \cdots \otimes P(n_r)$ in order to make explicit the conditions which η and μ have to satisfy as coalgebra morphisms. The result reads as follows: the preservation of coalgebra structures by the operadic unit $\eta : \mathbb{1} \rightarrow P(1)$ is equivalent to the commutativity of the diagrams

$$(a) \quad \begin{array}{ccc} \mathbb{1} & \xrightarrow{\eta} & P(1) \\ & \searrow & \downarrow \epsilon \\ & & \mathbb{1} \end{array} \quad = \quad \begin{array}{ccc} \mathbb{1} & \xrightarrow{\eta} & P(1) \\ \simeq \downarrow & & \downarrow \Delta \\ \mathbb{1} \otimes \mathbb{1} & \xrightarrow{\eta \otimes \eta} & P(1) \otimes P(1) \end{array} ,$$

where we use the notation ϵ (respectively, Δ) to refer to the counit (respectively, coproduct) of each $P(n)$; the preservation of coalgebra structures by the composition product $\mu : P(r) \otimes P(n_1) \otimes \cdots \otimes P(n_r) \rightarrow P(n_1 + \cdots + n_r)$ is equivalent to the

commutativity of the diagrams

$$(b) \quad \begin{array}{ccc} P(r) \otimes P(n_1) \otimes \cdots \otimes P(n_r) & \xrightarrow{\eta} & P(n_1 + \cdots + n_r) , \\ \epsilon \otimes \epsilon \otimes \cdots \otimes \epsilon \downarrow & & \downarrow \epsilon \\ \mathbb{1} & \xrightarrow{=} & \mathbb{1} \end{array}$$

$$\begin{array}{ccc} P(r) \otimes P(n_1) \otimes \cdots \otimes P(n_r) & \xrightarrow{\mu} & P(n_1 + \cdots + n_r) \\ \Delta \otimes \Delta \otimes \cdots \otimes \Delta \downarrow & & \downarrow \Delta \\ (P(r) \otimes P(r)) \otimes (P(n_1) \otimes P(n_1)) \otimes \cdots \otimes (P(n_r) \otimes P(n_r)) & & \\ \simeq \downarrow & & \\ (P(r) \otimes P(n_1) \otimes \cdots \otimes P(n_r)) \otimes (P(r) \otimes P(n_1) \otimes \cdots \otimes P(n_r)) & \xrightarrow{\mu \otimes \mu} & P(n_1 + \cdots + n_r) \otimes P(n_1 + \cdots + n_r) \end{array} .$$

In the case where \mathcal{M} is the category of \mathbb{k} -modules and $\mathbb{1} = \mathbb{k}$ (and similarly in the context of graded, differential graded, simplicial and cosimplicial modules), the requirement that $\eta : \mathbb{1} \rightarrow P(1)$ is a morphism of coalgebras amounts to the assumption that the operadic unit element $1 \in P(1)$ (determining η) is group-like, because so is the unit 1 in the ground ring \mathbb{k} , regarded as a coalgebra. In point-wise terms, the commutation relation expressed by the diagrams in (b) read

$$\epsilon(p(q_1, \dots, q_r)) = \epsilon(p) \cdot (\epsilon(q_1) \cdot \dots \cdot \epsilon(q_r))$$

$$\text{and} \quad \sum_{(p), (q_1), \dots, (q_r)} p'(q'_1, \dots, q'_r) \otimes p''(q''_1, \dots, q''_r),$$

for any $p \in P(r)$, $q_1 \in P(n_1), \dots, q_r \in P(n_r)$, where we use the notation $\Delta(x) = \sum_{(x)} x' \otimes x''$ to represent the expansion of the coproduct of any element x in a coalgebra.

In general, the observations of this paragraph imply that we can define operads in counitary cocommutative coalgebras as operads in the ground category \mathcal{P} , where each $P(r)$ is equipped with a counit $\epsilon : P(r) \rightarrow \mathbb{1}$ and a coproduct $\Delta : P(r) \rightarrow P(r) \otimes P(r)$, defining a counitary cocommutative coalgebra structure on $P(r)$, and so that the diagrams (a-b) commute, for all $r \geq 0$, $n_1, \dots, n_r \geq 0$.

To give an abstract interpretation of the compatibility conditions expressed by these commutative diagrams, we will check that the category of operads inherits a tensor product from the ground category $\mathfrak{X} : \mathcal{O}p \times \mathcal{O}p \rightarrow \mathcal{O}p$, so that the doubled factors in the tensor products of (a-b) can be interpreted as components of a tensor square $P^{\boxtimes 2}$ in $\mathcal{O}p$. We devote the next paragraphs to this subject. This tensor product $\boxtimes : \mathcal{O}p \times \mathcal{O}p \rightarrow \mathcal{O}p$ will be called the arity-wise tensor product of operads.

2.2.3. The arity-wise tensor product of operads. Let $P, Q \in \mathcal{O}p$. The components of the operad $P \boxtimes Q$ are given by the obvious formula $(P \boxtimes Q)(r) = P(r) \otimes Q(r)$ in each arity $r \in \mathbb{N}$, where we form the tensor product of the objects $P(r)$ and $Q(r)$ in the ground symmetric monoidal category \mathcal{M} . The diagonal action of permutations $w \in \Sigma_r$ on the tensor product $P(r) \otimes Q(r)$ provides the object $(P \boxtimes Q)(r) = P(r) \otimes Q(r)$ with an action of the symmetric group Σ_r , for each $r \in \mathbb{N}$. The unit of the operad $P \boxtimes Q$ is given by the composite morphism

$$\mathbb{1} \xrightarrow{\simeq} \mathbb{1} \otimes \mathbb{1} \xrightarrow{\eta_P \otimes \eta_Q} P(1) \otimes Q(1)$$

involving the operadic units of P and Q on the different factors of the tensor product $(P \boxtimes Q)(1) = P(1) \otimes Q(1)$. The composition products of $P \boxtimes Q$ are defined by the composite morphisms

$$\begin{aligned} & (P(r) \otimes Q(r)) \otimes (P(n_1) \otimes Q(n_1)) \otimes \cdots \otimes (P(n_r) \otimes Q(n_r)) \\ & \xrightarrow{\cong} (P(r) \otimes P(n_1) \otimes \cdots \otimes P(n_r)) \otimes (Q(r) \otimes Q(n_1) \otimes \cdots \otimes Q(n_r)) \\ & \xrightarrow{\mu_P \otimes \mu_Q} P(n_1 + \cdots + n_r) \otimes Q(n_1 + \cdots + n_r), \end{aligned}$$

where we apply an appropriate tensor permutation to gather the factors attached to each operad P and Q before applying the composition products of these operads. We immediately check that these structure morphisms satisfy the equivariance, unit and associativity axioms of operads. Accordingly, our construction, which is also obviously natural with respect to $P, Q \in \mathcal{Op}$, yields a bifunctor $\boxtimes : \mathcal{Op} \times \mathcal{Op} \rightarrow \mathcal{Op}$.

We can readily see that the commutative operad Com_+ , defined in Proposition 2.1.2 and consisting of the unit object $\mathbb{1}$ in all arities $Com_+(r) = \mathbb{1}$, forms a unit for the arity-wise tensor product of operads. We also have a natural associativity (respectively, symmetry) isomorphism on \boxtimes given by the arity-wise application of the associativity (respectively, symmetry) isomorphism of the tensor product \otimes in the ambient category \mathcal{M} . We simply have to check that the structure isomorphisms obtained that way preserves the internal structure of operads, but this assertion follows from formal verifications. We conclude that the bifunctor $\boxtimes : \mathcal{Op} \times \mathcal{Op} \rightarrow \mathcal{Op}$ is the tensor product of a symmetric monoidal structure on \mathcal{Op} .

A counitary cocommutative coalgebra in \mathcal{Op} formally consists of an operad $P \in \mathcal{Op}$ equipped with a counit (an augmentation), defined by a morphism $\epsilon : P \rightarrow Com_+$, and a coproduct $\Delta : P \rightarrow P \boxtimes P$, all formed in the category of operads, so that the counit, coassociativity, and cocommutativity relations of §2.0.3 hold. We immediately see, by definition of the arity-wise tensor product \boxtimes , that giving these structure morphisms amounts to providing each $P(r)$ with a counitary cocommutative coalgebra structure commuting with the action of symmetric groups. We also immediately see that, for the morphisms $\epsilon : P \rightarrow Com_+$ and $\Delta : P \rightarrow P \boxtimes P$, the preservation of operad units and composition products amounts to the commutativity of the diagrams (a-b) in §2.2.2. Accordingly, we have the following result:

PROPOSITION 2.2.4. *The Hopf operads, initially defined as operads in counitary cocommutative coalgebras in §2.2.1, can equivalently be defined as counitary cocommutative coalgebras in operads, where we take the arity-wise tensor product of §2.2.3 to provide the category of operads with a symmetric monoidal structure. \square*

We crucially need the equivalence established in this proposition for the definition Hopf operads by generators and relations (see Proposition 2.2.10).

In §2.0.3, we mention that the tensor unit $\mathbb{1}$ represents the terminal object of the category of counitary cocommutative coalgebras, and the tensor product represents the cartesian product in that category. The same results hold in the operad context:

PROPOSITION 2.2.5.

- (a) *The unitary commutative operad Com_+ , giving the unit object for the arity-wise tensor product of operads, inherits a natural Hopf operad structure and defines the terminal object of the category of Hopf operads.*

- (b) *The arity-wise tensor product of Hopf operads inherits a natural Hopf operad structure, so that the arity-wise tensor product induces a bifunctor $\boxtimes : \mathcal{H}opf\mathcal{O}p \times \mathcal{H}opf\mathcal{O}p \rightarrow \mathcal{H}opf\mathcal{O}p$ and gives a symmetric monoidal structure on the category of Hopf operads, with the unitary commutative operad \mathbf{Com}_+ as unit object.*
- (c) *The tensor product of Hopf operads $P \boxtimes Q \in \mathcal{H}opf\mathcal{O}p$, considered in (b), actually represents the cartesian product of P and Q in $\mathcal{H}opf\mathcal{O}p$. The structure projections $P \xleftarrow{p} P \boxtimes Q \xrightarrow{q} Q$, which characterize this cartesian product, are identified with the tensor products $p = id \boxtimes \epsilon$ and $q = \epsilon \boxtimes id$, where we consider the counit morphisms $\epsilon : P \rightarrow \mathbf{Com}_+$ (respectively, $\epsilon : Q \rightarrow \mathbf{Com}_+$) of the Hopf operad structure on P (respectively, Q).*

PROOF. This result follows from the identity $\mathcal{H}opf\mathcal{O}p = \mathcal{O}p\mathbf{Com}_+^c$, established in Proposition 2.2.4, and the observations of §2.0.3, concerning the categorical interpretation of the tensor product of coalgebras in a symmetric monoidal category, which we apply to the category of operads $\mathcal{M} = \mathcal{O}p$. \square

The assertions of this proposition can also be deduced from the result of Proposition 1.2.4, asserting that limits of operads are created in the underlying category. We simply note that Proposition 1.2.4 holds as soon as limit exists in the ground category, and we use the observations of §2.0.3 to get the definition of terminal objects and cartesian products in categories of counitary cocommutative coalgebras, without

We now examine the adjunction between symmetric sequences and operads in the context of Hopf operads. We assume for the construction of free operads that the base category \mathcal{M} is equipped with colimits, and that the tensor product satisfies the colimit preservation requirement of §0.8(a).

In parallel to the terminology of Hopf operad, we may use the expression of Hopf symmetric sequence to refer to a symmetric sequence in counitary cocommutative coalgebras. We may also use the notation $\mathcal{H}opfSeq$, instead of \mathbf{Com}_+^cSeq , to refer to that category of symmetric sequences. We first examine the definition of a Hopf symmetric sequence structure.

2.2.6. *Hopf symmetric sequences and the definition of free Hopf operads.* We can obviously extend the definition of the arity-wise tensor product to symmetric sequences. We then obtain a bifunctor $\boxtimes : Seq \times Seq \rightarrow Seq$ providing Seq with a symmetric monoidal structure (we just retain the action of symmetric groups from the construction of §2.2.3). The tensor unit in the category Seq is still given by the unitary commutative operad \mathbf{Com}_+ , of which we forget the operadic composition structure.

We can readily identify a Hopf symmetric sequence with a symmetric sequence in the base category $\mathcal{M} \in Seq$ equipped with a counit $\epsilon : \mathcal{M} \rightarrow \mathbf{Com}_+$ and a coproduct $\Delta : \mathcal{M} \rightarrow \mathcal{M} \boxtimes \mathcal{M}$, formed by the collection of counits $\epsilon : \mathcal{M}(r) \rightarrow \mathbb{1}$ and the coproduct $\Delta : \mathcal{M}(r) \rightarrow \mathcal{M}(r) \otimes \mathcal{M}(r)$ on the components of \mathcal{M} , so that the counit, coassociativity, and cocommutativity relations of §2.0.3 are satisfied. We therefore have an identity between the category of Hopf symmetric sequences and the category of counitary cocommutative coalgebras in Seq . In our notation, this equivalence reads $\mathcal{H}opfSeq = \mathbf{Com}_+^cSeq = Seq\mathbf{Com}_+^c$.

We can apply the construction of the free operad to the symmetric monoidal category of counitary cocommutative coalgebras whenever we have colimits in the

base symmetric monoidal category \mathcal{M} . (Just recall that the category of counitary cocommutative coalgebras has colimits as well, which are actually created in \mathcal{M} .) We then obtain a Hopf operad $\mathbb{O}(M)$, naturally associated to any Hopf symmetric sequence M , and characterized by the universal property of Proposition 1.2.2 in the category of Hopf operads (or by the equivalent adjunction relation of Theorem 1.2.1).

We have already observed that the forgetful functor $\omega : \mathcal{Com}_+^c \rightarrow \mathcal{M}$, from counitary cocommutative coalgebras to the ground category, is symmetric monoidal by construction, and as a consequence, induces a functor $\omega : \mathcal{HopfOp} \rightarrow \mathcal{Op}$ from Hopf operads to operads. According to the discussion of §§2.2.1-2.2.4, we can also identify this functor with a forgetful functor, which retains the operad structure in Hopf operads and forget about the coalgebra structure attached to each component. We also have an obvious forgetful functor $\omega : \mathcal{HopfSeq} \rightarrow \mathcal{Seq}$ on Hopf symmetric sequences. We now study the interplay between these Hopf forgetful functors and the various free operad functors attached to each category.

The explicit construction of the free operad $\mathbb{O}(M)$ in §II.A involves a combination of colimits and tensor products. On the other hand, we mention in §2.0.3 that the forgetful functor $\omega : \mathcal{Com}_+^c \rightarrow \mathcal{M}$ creates colimits (in addition to tensor products). From this observation, we may immediately deduce that the forgetful functor $\omega : \mathcal{HopfOp} \rightarrow \mathcal{Op}$ preserves free operads. But we aim to establish this result by another approach, by relying on our interpretation of Hopf operads as coalgebras in operads. The argument is based on the following construction:

LEMMA 2.2.7. *Let M be a Hopf symmetric sequence. Let $\mathbb{O}(M)$ be the free operad associated to M , and formed in the ground category after forgetting the internal coalgebra structure of M .*

- (a) *The counits $\epsilon : M(r) \rightarrow \mathbb{1}$ and the coproducts $\Delta : M(r) \rightarrow M(r) \otimes M(r)$, defining the counitary cocommutative coalgebra structure of the object M , extend to operad morphisms $\epsilon : \mathbb{O}(M) \rightarrow \mathcal{Com}_+$ and $\Delta : \mathbb{O}(M) \rightarrow \mathbb{O}(M) \boxtimes \mathbb{O}(M)$, providing $\mathbb{O}(M)$ with the structure of a Hopf operad.*
- (b) *Let $f : M \rightarrow P$ be a morphism of Hopf symmetric sequences, where P is a Hopf operad. Let $\phi_f : \mathbb{O}(M) \rightarrow P$ be the unique morphism factorizing f in the category of operads. The free operad $\mathbb{O}(M)$ inherits a Hopf operad structure by assertion (a). The above morphism ϕ_f automatically preserves this additional coalgebra structure and as a consequence defines a factorization of f in the category of Hopf operads.*
- (c) *In the construction of (a), the universal morphism attached to the free operad $\iota : M \rightarrow \mathbb{O}(M)$ forms a morphism of Hopf symmetric sequences. In the construction of (b), if we form the morphism $\lambda : \mathbb{O}(P) \rightarrow P$, attached to the identity of P and defining the adjunction augmentation of the free operad, then we obtain a morphism of Hopf operads.*

PROOF. Recall that the collection of counits $\epsilon : M(r) \rightarrow \mathbb{1}$, attached to the coalgebra structure of each $M(r)$, can be viewed as a morphism of symmetric sequences towards the unitary commutative operad \mathcal{Com}_+ . The existence of the operad morphism $\epsilon : \mathbb{O}(M) \rightarrow \mathcal{Com}_+$ extending these counits immediately follows from the universal property of the free operad, as stated in Proposition 1.2.2.

By composing the diagonals $\Delta : M(r) \rightarrow M(r) \otimes M(r)$ with a tensor product of the universal morphisms $\iota : M(r) \rightarrow \mathbb{O}(M)(r)$ in each arity, we also obtain a morphism $\Delta : M \rightarrow \mathbb{O}(M) \boxtimes \mathbb{O}(M)$. By applying the universal property of the free

operad, we obtain again an operad morphism $\Delta : \mathbb{O}(M) \rightarrow \mathbb{O}(M) \boxtimes \mathbb{O}(M)$ extending this morphism of symmetric sequences.

By applying the uniqueness requirement in the universal property of free operads (see Proposition 1.2.2 again), we immediately obtain that the counit, coassociativity and cocommutativity relations of coalgebras hold at the level of the free operad $\mathbb{O}(M)$, for the just defined morphisms, as soon as they hold at the level of the symmetric sequence M .

The universal morphism $\iota : M \rightarrow \mathbb{O}(M)$ forms a morphism of Hopf symmetric sequences by construction of the coalgebra structure on $\mathbb{O}(M)$. Thus, the first assertion of (c) is immediate. The uniqueness requirement in the universal property of free operads also implies that the morphism $\phi_f : \mathbb{O}(M) \rightarrow P$ associated to a morphism of Hopf symmetric sequences in (b) intertwines coalgebra structures and hence, forms a morphism of Hopf operads. The second assertion of (c), regarding the adjunction augmentation $\lambda : \mathbb{O}(P) \rightarrow P$, is also immediate from this result. \square

Then we obtain:

PROPOSITION 2.2.8. *The free operad $\mathbb{O}(M)$, together with the Hopf structure constructed in the previous lemma, forms the free object associated to M in the category of Hopf operads.*

PROOF. This proposition is a formal consequence of the results of assertions (b-c) in Lemma 2.2.7. \square

Lemma 2.2.7 also implies the following result on the free operad adjunction:

PROPOSITION 2.2.9. *The functors defined by the forgetting of coalgebra structures in Hopf objects fit in a commutative diagram of functors*

$$\begin{array}{ccc} \mathcal{H}opfSeq & \begin{array}{c} \xrightarrow{\mathbb{O}} \\ \xleftarrow{\omega} \end{array} & \mathcal{H}opf\mathbb{O}p, \\ \omega \downarrow \text{dotted} & & \omega \downarrow \text{dotted} \\ Seq & \begin{array}{c} \xrightarrow{\mathbb{O}} \\ \xleftarrow{\omega} \end{array} & \mathbb{O}p \end{array}$$

where we consider the adjoint forgetful and free object functors between symmetric sequences and operads. These forgetful functors also induce mappings on morphism sets

$$\begin{array}{ccc} \mathbf{Mor}_{\mathcal{H}opf\mathbb{O}p}(\mathbb{O}(M), P) & \xrightarrow{\simeq} & \mathbf{Mor}_{\mathcal{H}opfSeq}(M, P) \\ \omega \downarrow \text{dotted} & & \omega \downarrow \text{dotted} \\ \mathbf{Mor}_{\mathbb{O}p}(\mathbb{O}(M), P) & \xrightarrow{\simeq} & \mathbf{Mor}_{Seq}(M, P) \end{array}$$

that intertwine the correspondence (materialized by the horizontal arrows in the diagram) which arises from the definition of free operads as a left adjoint.

PROOF. The assertion of Proposition 2.2.8 implies that the forgetting of coalgebra structures preserves free objects in operads. In Lemma 2.2.7, assertion (c) similarly implies that the forgetting of coalgebra structures preserves the unit morphism and the augmentation morphism of the free operad adjunction. From this observation, we immediately conclude that the forgetting of coalgebra structures also intertwines the adjunction correspondence on morphisms. \square

In §1.2, we briefly explain that the free operad $\mathbb{O}(M)$ intuitively consists of formal operadic composites of elements $\xi \in M(n)$ (whenever the notion of element makes sense). In this interpretation, the construction of Lemma 2.2.7 amounts to extending the counit (respectively, coproduct) of M to such composites by using the point-wise commutation relations of §2.2.2. We use this idea soon, when we explicitly determine the counit and coproduct of composition products in operads defined by generators and relations (see §2.2.11).

We now specialize our study to Hopf operads in modules over a ring $\mathcal{M} = \text{Mod}$. We explain in §1.2.9 that operads in module categories can be defined by generators and relations as quotients $P = \mathbb{O}(M) / \langle z^\alpha, \alpha \in \mathcal{J} \rangle$, where we consider an ideal $\langle z^\alpha, \alpha \in \mathcal{J} \rangle$ in a free operad $\mathbb{O}(M)$. In the context of Hopf operads, we have the following result:

PROPOSITION 2.2.10. *Let M be a Hopf symmetric sequence (in \mathbb{k} -modules). We apply the construction of Lemma 2.2.7 to obtain a Hopf structure on the free operad associated to M . Let $S = \langle z^\alpha, \alpha \in \mathcal{J} \rangle$ be the ideal generated by a collection of elements $z^\alpha \in S(n_\alpha)$ in the free operad $\mathbb{O}(M)$. If $\epsilon(z^\alpha) = 0$ and $\Delta(z^\alpha) \in S(n_\alpha) \otimes \mathbb{O}(M)(n_\alpha) + \mathbb{O}(M)(n_\alpha) \otimes S(n_\alpha)$ for each $z^\alpha \in S(n_\alpha)$, then:*

- (a) *The operad $\mathbb{O}(M) / \langle z^\alpha, \alpha \in \mathcal{J} \rangle$ inherits a quotient Hopf operad structure from the free operad $\mathbb{O}(M)$.*
- (b) *The morphisms of Hopf operads $\bar{\phi}_f : \mathbb{O}(M) / \langle z^\alpha, \alpha \in \mathcal{J} \rangle \rightarrow \mathcal{Q}$ defined on this quotient are in obvious bijection with the morphisms of Hopf operads $\phi_f : \mathbb{O}(M) \rightarrow \mathcal{Q}$ such that $\phi_f(z^\alpha) = 0$ for each generating element of the ideal $z^\alpha \in S(n_\alpha)$.*

In the situation of this proposition, we also say that the ideal $S = \langle z^\alpha, \alpha \in \mathcal{J} \rangle$ forms a Hopf ideal in the operad $\mathbb{O}(M)$.

PROOF. The requirement $\epsilon(z^\alpha) = 0$ implies that ϵ induces a morphism on the quotient $\mathbb{O}(M) / \langle z^\alpha, \alpha \in \mathcal{J} \rangle$, and hence provides this quotient operad with a counit $\epsilon : \mathbb{O}(M) / \langle z^\alpha, \alpha \in \mathcal{J} \rangle \rightarrow \mathbf{Com}_+$. The requirement $\Delta(z^\alpha) \in S(n_\alpha) \otimes \mathbb{O}(M)(n_\alpha) + \mathbb{O}(M)(n_\alpha) \otimes S(n_\alpha)$ is equivalent to the vanishing of $\Delta(z^\alpha)$ in $(\mathbb{O}(M) / S \boxtimes \mathbb{O}(M) / S)(n_\alpha) = \mathbb{O}(M)(n_\alpha) / S(n_\alpha) \otimes \mathbb{O}(M)(n_\alpha) / S(n_\alpha) = \mathbb{O}(M)(n_\alpha) \otimes \mathbb{O}(M)(n_\alpha) / S(n_\alpha) \otimes \mathbb{O}(M)(n_\alpha) + \mathbb{O}(M)(n_\alpha) \otimes S(n_\alpha)$, and implies that $\Delta : \mathbb{O}(M) \rightarrow \mathbb{O}(M) \boxtimes \mathbb{O}(M)$ induces a morphism $\Delta : \mathbb{O}(M) / S \rightarrow \mathbb{O}(M) / S \boxtimes \mathbb{O}(M) / S$ on the quotient operad $\mathbb{O}(M) / S = \mathbb{O}(M) / \langle z^\alpha, \alpha \in \mathcal{J} \rangle$. These morphisms, obtained by a quotient process, naturally satisfy the counit, coassociativity, and cocommutativity relations of coalgebras and hence, provide the operad $\mathbb{O}(M) / \langle z^\alpha, \alpha \in \mathcal{J} \rangle$ with a well-defined Hopf structure.

To check the second assertion of the proposition, simply observe that the morphism $\bar{\phi}_f : \mathbb{O}(M) / \langle z^\alpha, \alpha \in \mathcal{J} \rangle \rightarrow \mathcal{Q}$, induced by the morphism of Hopf operads $\phi_f : \mathbb{O}(M) \rightarrow \mathcal{Q}$, naturally preserves coalgebra structures as well, and hence, defines a morphism of Hopf operads. \square

2.2.11. The basic examples of Hopf operads. The assertions of Proposition 2.2.5 include the statement that the unitary commutative operad \mathbf{Com}_+ has a natural Hopf structure. The same result holds for the non-unitary version of this operad \mathbf{Com} and can also be deduced from the identity between the components of this operad in arity $r > 0$ and the tensor unit $\mathbb{1}$. The counit $\epsilon : \mathbf{Com}(r) \rightarrow \mathbb{1}$ is given by the identity of $\mathbb{1}$ in arity $r > 0$, and by the initial morphism $\emptyset \rightarrow \mathbb{1}$ in arity

$r = 0$. The coproduct $\Delta : \mathbf{Com}(r) \rightarrow \mathbf{Com}(r) \otimes \mathbf{Com}(r)$ is given by the isomorphism $\mathbb{1} \xrightarrow{\cong} \mathbb{1} \otimes \mathbb{1}$ in arity $r > 0$, and by the initial morphism $\emptyset \rightarrow \emptyset \otimes \emptyset$ in arity $r = 0$.

To illustrate our constructions, we check that this structure result can be retrieved from the statement of Proposition 2.2.10 and from the presentation commutative operad in §1.2.10. We then assume that the ground symmetric monoidal category is a category of modules over a ring.

Recall that the generating symmetric sequence of the commutative operad is defined by $M_{\mathbf{Com}}(2) = \mathbb{k}[\mu(x_1, x_2)] = \mathbb{k}$, where $\mu = \mu(x_1, x_2)$ denotes an operation on which Σ_2 acts trivially, and $M_{\mathbf{Com}}(r) = 0$ for $r \neq 2$. We provide the module $M_{\mathbf{Com}}(2) = \mathbb{k}[\mu(x_1, x_2)]$ with the coalgebra structure such that $\epsilon(\mu) = 1$ and $\Delta(\mu) = \mu \otimes \mu$ for this generating operation. We use the preservation of operadic composition structures to determine the image of the generating relations of \mathbf{Com} under the counit and the coproduct in the free operad:

$$\begin{aligned} \epsilon(\mu(\mu, 1) - \mu(1, \mu)) &= 1 - 1 = 0, \\ \Delta(\mu(\mu, 1) - \mu(1, \mu)) &= (\mu \otimes \mu)(\mu \otimes \mu, 1 \otimes 1) - (\mu \otimes \mu)(1 \otimes 1, \mu \otimes \mu) \\ &= \mu(\mu, 1) \otimes \mu(\mu, 1) - \mu(1, \mu) \otimes \mu(1, \mu) \\ &= (\mu(\mu, 1) - \mu(1, \mu)) \otimes \mu(\mu, 1) + \mu(1, \mu) \otimes (\mu(\mu, 1) - \mu(1, \mu)). \end{aligned}$$

We see, from this computation, that the generating relations of the commutative operad generate a Hopf ideal. Hence, the assumptions of Proposition 2.2.10 are satisfied, and we retrieve that \mathbf{Com} inherits a well-defined Hopf operad structure, such that $\epsilon(\mu) = 1$ and $\Delta(\mu) = \mu \otimes \mu$ for the generating operation $\mu = \mu(x_1, x_2)$.

The unitary and the non-unitary version of the associative operad also inherits a Hopf structure. Let us see how to retrieve this structure result from the presentation again. The generating symmetric sequence of the associative operad is given by $M_{\mathbf{As}}(2) = \mathbb{k}[\mu(x_1, x_2), \mu(x_2, x_1)] = \mathbb{k}[\Sigma_2]$, where $\mu = \mu(x_1, x_2)$ denotes an operation on which Σ_2 acts regularly, and $M_{\mathbf{As}}(r) = 0$ for $r \neq 2$. We provide the module $M_{\mathbf{As}}(2)$ with the coalgebra structure such that $\epsilon(\mu) = 1$ and $\Delta(\mu) = \mu \otimes \mu$. The definition of the counit and of the coproduct of the transposed operation $(1 \ 2) \cdot \mu = \mu(x_2, x_1)$ is then forced by the equivariance requirement. We check, as in the case of the commutative operad, that $\mu(\mu, 1) - \mu(1, \mu)$ generates a Hopf ideal, from which we conclude again that the operad \mathbf{As} inherits a well-defined Hopf structure.

In the case of the Lie operad, we have a generating symmetric sequence such that $M_{\mathbf{Lie}}(2) = \mathbb{k}[\lambda(x_1, x_2)] = \mathbb{k}^\pm$ where \mathbb{k}^\pm denotes the signature representation. We have in this case no possibility of fixing a counit $\epsilon(\lambda) \in \mathbb{k}$, and a coproduct $\Delta(\lambda) \in \mathbf{Lie}(2) \otimes \mathbf{Lie}(2)$, so that: the counit relations hold, the equivariance requirements of operad morphisms are satisfied and the Jacobi relation is canceled by the counit in \mathbb{k} , and by the coproduct in $\mathbf{Lie}(3) \otimes \mathbf{Lie}(3)$ as well. Hence, we have no Hopf structure on the Lie operad.

2.2.12. *The example of the Poisson operad.* Though we have no Hopf structure on the Lie operad, we can define an appropriate counit and coproduct for the corresponding generating operation λ in the Poisson operad. Recall that the Poisson operad \mathbf{Pois} is defined by a presentation of the form

$$\begin{aligned} \mathbf{Pois} = \mathbb{O}(\mathbb{k}\mu(x_1, x_2) \oplus \mathbb{k}\lambda(x_1, x_2) : & \mu(\mu(x_1, x_2), x_3) \equiv \mu(x_1, \mu(x_2, x_3)), \\ & \lambda(\lambda(x_1, x_2), x_3) + \lambda(\lambda(x_2, x_3), x_1) + \lambda(\lambda(x_3, x_1), x_2) \equiv 0, \\ & \lambda(\mu(x_1, x_2), x_3) \equiv \mu(\lambda(x_1, x_3), x_2) + \mu(x_1, \lambda(x_2, x_3))), \end{aligned}$$

where the action of the symmetric group in arity 2 is determined by $(1\ 2) \cdot \mu = \mu$ and $(1\ 2) \cdot \lambda = -\lambda$. We extend the formula of the commutative operad to define the counit and the coproduct of the product operation $\mu = \mu(x_1, x_2)$. We define the counit and the coproduct of the Lie bracket operation $\lambda = \mu(x_1, x_2)$ by $\epsilon(\lambda) = 0$ and $\Delta(\lambda) = \lambda \otimes \mu + \mu \otimes \lambda$. Again, we easily check (exercise, adapt the verifications performed in §2.2.11 for the commutative operad) that the generating relations of the Poisson operad form a Hopf ideal, and therefore we have a well-defined Hopf structure on the Poisson operad. We use a graded variant of this Hopf structure in our study of the homology of E_n -operads (§4.2).

2.2.13. *Remark: tensor product of algebras over Hopf operads.* The existence of a Hopf structure on an operad P implies that the associated category of algebras \mathcal{P} inherits a symmetric monoidal structure from the underlying symmetric monoidal category \mathcal{M} . Indeed, the tensor product of P -algebras $A, B \in \mathcal{P}$ inherits an action of P , given by the composite morphisms $P(r) \otimes (A \otimes B)^{\otimes r} \xrightarrow{\Delta} (P(r) \otimes P(r)) \otimes (A \otimes B)^{\otimes r} \xrightarrow{\cong} (P(r) \otimes A^{\otimes r}) \otimes (P(r) \otimes B^{\otimes r}) \xrightarrow{\lambda_A \otimes \lambda_B} A \otimes B$, for any $r \in \mathbb{N}$, where we consider the coproduct of P , followed by the obvious tensor permutation and the tensor product of the evaluation morphisms attached to the P -algebras. The tensor unit $\mathbb{1}$ also inherits an action of the operad P by restriction through the counit morphism $\epsilon : P \rightarrow \text{Com}_+$ (using the natural commutative algebra structure of $\mathbb{1}$). The counit, coassociativity, and cocommutativity relations, at the level of the coalgebra structure of the Hopf operad P , imply that the unit, associativity, and symmetry isomorphisms of the ground category define P -algebra morphisms when we deal with tensor products of P -algebras. Hence, we have a whole symmetric monoidal structure on the category of P -algebras.

In the case of the commutative operad, we retrieve with this observation the basic symmetric monoidal structure of §2.0.2. In the case of the associative operad, we retrieve the similarly defined symmetric monoidal structure alluded to in the introduction of §2.0.

2.2.14. *Changes in the context of connected operads.* Recall that the category of connected operads $\mathcal{O}p_{01}$, as defined in §1.1.21, consists of the operads P satisfying $P(0) = \emptyset$ when the tensor product of \mathcal{M} preserves colimits (otherwise we just forget about arity zero terms) and $P(1) = \mathbb{1}$.

The constructions of §§2.2.3-2.2.5 can readily be adapted in the context of connected operads. We actually have $(P \boxtimes Q)(0) = \emptyset$ when the tensor product of \mathcal{M} preserves colimits, and $(P \boxtimes Q)(1) = \mathbb{1}$ in general, so that the category $\mathcal{O}p_{01}$ is equipped with a well-defined arity-wise tensor product inherited from the category of operads. We accordingly have a symmetric monoidal structure on $\mathcal{O}p_{01}$. We just need to observe that the unit object of this category is the non-unitary version of the commutative operad Com (defined in Proposition 2.1.1).

The result of Proposition 2.2.4 remains valid for connected operads, and so does the result of Proposition 2.2.5, provided that we replace the unitary version of the commutative operad Com_+ by the non-unitary one Com .

2.3. Appendix: functors between symmetric monoidal categories

In various constructions, we have to transport structures (like commutative algebras) from one symmetric monoidal category \mathcal{M} to another \mathcal{N} by using functors preserving the internal structures of symmetric monoidal categories. For this aim, we deal with functors preserving symmetric monoidal structures, in a strict

or relaxed sense. The purpose of this appendix section is to make explicit extra structures, consisting of natural equivalences or natural transformations, which we use to govern the commutation of tensor products and functors $S : \mathcal{M} \rightarrow \mathcal{N}$.

2.3.1. *Symmetric monoidal transformations.* We often deal with functors $S : \mathcal{M} \rightarrow \mathcal{N}$ satisfying $S(\mathbb{1}) = \mathbb{1}$ for the unit object $\mathbb{1} \in \mathcal{M}$, and equipped with a natural transformation $\theta : S(A) \otimes S(B) \rightarrow S(A \otimes B)$, so that natural unit, associativity and symmetry constraints, expressed by the commutativity of the following diagrams, hold:

$$\begin{array}{ccc}
S(A) \otimes S(\mathbb{1}) & \xrightarrow{\theta} & S(A \otimes \mathbb{1}) , \\
\uparrow = & & \downarrow \simeq \\
S(A) \otimes \mathbb{1} & \xrightarrow{\simeq} & S(A)
\end{array}
, \quad
\begin{array}{ccc}
S(\mathbb{1}) \otimes S(A) & \xrightarrow{\theta} & S(\mathbb{1} \otimes A) , \\
\uparrow = & & \downarrow \simeq \\
\mathbb{1} \otimes S(A) & \xrightarrow{\simeq} & S(A)
\end{array}$$

$$\begin{array}{ccc}
S(A) \otimes S(B) \otimes S(C) & \xrightarrow{\theta \otimes id} & S(A \otimes B) \otimes S(C) , \\
\downarrow id \otimes \theta & & \downarrow \theta \\
S(A) \otimes S(B \otimes C) & \xrightarrow{\theta} & S(A \otimes B \otimes C)
\end{array}
, \quad
\begin{array}{ccc}
S(A) \otimes S(B) & \xrightarrow{\theta} & S(A \otimes B) . \\
\downarrow \simeq & & \downarrow \simeq \\
S(B) \otimes S(A) & \xrightarrow{\theta} & S(B \otimes A)
\end{array}$$

In this situation, we say that the functor S is unit-pointed (to refer to the identity $S(\mathbb{1}) = \mathbb{1}$) and that θ defines a symmetric monoidal transformation on S . We have a dual situation where our functor S is equipped with a natural transformation going in the converse direction $\theta : S(A \otimes B) \rightarrow S(A) \otimes S(B)$ and satisfying a dual of our unit, associativity and symmetry constraints. We then say that θ defines a symmetric comonoidal transformation associated to S .

We may deal with an optimal situation, where a unit-pointed functor S is equipped with a symmetric monoidal transformation θ that gives an isomorphism $\theta : S(A) \otimes S(B) \xrightarrow{\simeq} S(A \otimes B)$, for every $A, B \in \mathcal{M}$ (or dually in the case of a symmetric comonoidal transformation). We say in this case that θ forms a symmetric monoidal equivalence and that $S : \mathcal{M} \rightarrow \mathcal{N}$ is a symmetric monoidal functor from \mathcal{M} to \mathcal{N} . (Some authors use the expression of strong symmetric monoidal functor to depict this situation.)

The functors which are unit pointed and equipped with a symmetric monoidal transformation in our sense form a subclass of the class of lax symmetric monoidal functors (simply called symmetric monoidal functors by certain authors). Indeed, to retrieve the general definition of a lax symmetric monoidal functor from our definition, we simply have to relax the identity requirement $S(\mathbb{1}) = \mathbb{1}$ and to assume the existence of a morphism $\eta : \mathbb{1} \rightarrow S(\mathbb{1})$ instead. Dually, the functors which are unit pointed and equipped with a symmetric comonoidal transformation in our sense form a subclass of the classical notion of colax symmetric monoidal functor.

Unit objects are preserved by all our examples of functors between symmetric monoidal categories. Therefore, we do not use the general notion of lax/colax functor in practice.

2.3.2. *Basic examples of symmetric monoidal functors.* The geometric realization functor $|-| : \mathcal{Simp} \rightarrow \mathcal{Top}$ (see §0.5) is a fundamental example of functor which carries a non trivial symmetric monoidal structure. Recall that the tensor product operation on simplicial sets and topological spaces is defined by the cartesian product of these categories. In this context, the canonical projections $K \xleftarrow{p} K \times L \xrightarrow{q} L$ induce morphisms $|K| \xleftarrow{p} |K \times L| \xrightarrow{q} |L|$ which we can put together to define a

natural transformation $\theta : |K \times L| \xrightarrow{q} |K| \times |L|$. This natural transformation is actually a homeomorphism for all $K, L \in \mathit{Simp}$ (see for instance [133, §III]), This result follows from a topological interpretation, in terms of simplicial decompositions of prisms, of the classical Eilenberg-Zilber equivalence (we refer to *loc. cit.* for details). For a point, we obviously have $|pt| = pt$, and the definition of the natural transformation $\theta : |K \times L| \xrightarrow{q} |K| \times |L|$ from universal categorical constructions automatically ensures that the unit, associativity and symmetry constraints of §2.3.1 are fulfilled.

The singular complex functor $\mathbf{Sing}_\bullet : \mathcal{T}op \rightarrow \mathit{Simp}$, which defines the right adjoint of the geometric realization functor $|-| : \mathit{Simp} \rightarrow \mathcal{T}op$ (see §0.5), is also symmetric monoidal. In this case, the identity $\mathbf{Sing}_\bullet(pt) = pt$ and the existence of an isomorphism $\mathbf{Sing}_\bullet(K \times L) \xrightarrow{\cong} \mathbf{Sing}_\bullet(K) \times \mathbf{Sing}_\bullet(L)$ immediately follows from the definition of $\mathbf{Sing}_\bullet : \mathcal{T}op \rightarrow \mathit{Simp}$ as a right adjoint.

To give another (even) simple(r) example: the functor $\mathbb{k}[-] : \mathit{Set} \rightarrow \mathit{Mod}$, defined by assigning the free \mathbb{k} -module $\mathbb{k}[X]$ generated by X to any set $X \in \mathit{Set}$ is symmetric monoidal since we have an obvious identity $\mathbb{k}[pt] = \mathbb{k}$ for the one point set $pt \in \mathit{Set}$, a natural isomorphism $\mathbb{k}[X] \otimes \mathbb{k}[Y] \xrightarrow{\cong} \mathbb{k}[X \times Y]$, for any cartesian product of sets $X, Y \in \mathit{Set}$, and we can also easily check that this natural transformation fulfills our unit, associativity and symmetry constraints. We go back to this example in §2.0.5.

The simplicial extension of the free \mathbb{k} -module functor $\mathbb{k}[-] : \mathit{Simp} \rightarrow \mathit{sMod}$ (considered in §0.3) is also symmetric monoidal (the symmetric monoidal structure of simplicial modules will be studied in §4.3).

The normalized chain complex functor $\mathbf{N}_* : \mathit{Simp} \rightarrow \mathit{dgMod}$, of which we recall the definition later on, is an instance of functor which is not symmetric monoidal in the sense specified in §2.3.1. In the case of this functor, we have a natural transformation $\theta : \mathbf{N}_*(X) \times \mathbf{N}_*(Y) \rightarrow \mathbf{N}_*(X \times Y)$, called the Eilenberg-MacLane morphism, which satisfy our unit, associativity and symmetry constraints, but this morphism is only a weak-equivalence and not an isomorphism (see [121, §§VIII.6-8]). We give a detailed account of this subject in §4.3.

2.3.3. Symmetric monoidal adjunctions. Suppose now we have a pair of adjoint functors $S : \mathcal{M} \rightleftharpoons \mathcal{N} : T$ between symmetric monoidal categories such that both S and T are symmetric monoidal. We then say that the adjunction is symmetric monoidal if the adjunction augmentation $\epsilon : S(T(X)) \rightarrow X$ and the adjunction unit $\eta : A \rightarrow T(S(A))$ are identity morphisms on unit objects, and make commute the diagrams

$$\begin{array}{ccc}
 S(T(X)) \otimes S(T(Y)) & \xrightarrow{\epsilon \otimes \epsilon} & X \otimes Y & , & A \otimes B & \xrightarrow{\eta} & S(T(A \otimes B)) & , \\
 \cong \downarrow & & \uparrow \epsilon & & \eta \otimes \eta \downarrow & & \uparrow \cong & \\
 S(T(X)) \otimes T(Y) & \xrightarrow{\cong} & S(T(X \otimes Y)) & & T(S(A)) \otimes T(S(B)) & \xrightarrow{\cong} & T(S(A) \otimes S(B)) &
 \end{array}$$

involving the symmetric monoidal transformations attached to S and T .

One can check (exercise) that the augmentation $\epsilon : |\mathbf{Sing}_\bullet(X)| \rightarrow X$ and the unit $\eta : K \rightarrow \mathbf{Sing}_\bullet(|K|)$ of the adjunction between the geometric realization $|-| : \mathit{Simp} \rightarrow \mathcal{T}op$ and the singular complex functor $\mathbf{Sing}_\bullet(-) : \mathcal{T}op \rightarrow \mathit{Simp}$ satisfy these relations. Hence, this adjunction $|-| : \mathit{Simp} \rightleftharpoons \mathcal{T}op : \mathbf{Sing}_\bullet(-)$ is symmetric monoidal in the sense defined in the present paragraph.

The Definition of Operadic Composition Structures Revisited

In the introductory chapter §1, we have given a first definition of the notion of an operad, and we have used this definition to explain the relationship between operads and algebras. In this second chapter, we go deeper into the study of the internal structures of operads themselves.

The first outcome of this second examination, explained in the first section of the chapter (§3.1), is a new definition, in terms of partial composition operations, of the composition structure of an operad. The equivalence between May's definition [134], considered in §1, and this definition in terms of partial composition operations is due to Martin Markl [127, 129], and is also used in the work of Ginzburg-Kapranov on the Koszul duality of operads [75]. For us, the partial composition operations have the important feature to satisfy homogeneous (quadratic) relations, unlike the full composition products considered in the definition of §1.1.1. The existence of this homogeneous structure is the crux of the Koszul reduction process of §10. Let us mention that examples of partial composition products were considered before the development of the theory of operads in the work of Murray Gerstenhaber on the Hochschild cochain complex (see [69]).

In a second part of the chapter (§§3.2-3.4), we examine the definition of operads such that $P_+(0) = \mathbb{1}$, where $\mathbb{1}$ is the tensor unit of the base category \mathcal{M} . In §1.2.8, we mentioned that such operads, which we call unitary operads, can be produced by the addition of the unit object $\mathbb{1}$ to the arity 0 component of a non-unitary operad P . To complete the definition of the composition structure of a unitary operad P_+ from an underlying non-unitary operad P , we have to assume that P is equipped with extra structures reflecting composition products with the additional term of the unitary operad. In §3.2, we give a conceptual interpretation, in terms of an extension of the underlying symmetric structure of an operad, of these unitary composition operations. In §3.3, we use the result of this analysis to give a reduced version of the categorical constructions of §1.2 in the context of unitary operads. In §3.4, we explain the definition of connected unitary operads, where further reductions of the structures introduced in §§3.2-3.3 can be considered.

The first instances of operads considered in May's monograph [134] are unitary (unital in the terminology of that reference), and May actually uses a unitary variant of the structure of a free algebra over an operad for the study of iterated loop spaces. We give a short survey of this subject in §3.2.

We have considered, so far, that the components of an operad $P(r)$ are indexed by non-negative integers $r \in \mathbb{N}$. Recall that an element $p \in P(r)$ intuitively represents an operation of r variables $p = p(x_1, \dots, x_r)$, indexed by the finite ordinal $\mathbf{r} = \{1 < \dots < r\}$. But in the construction of free operads, we have advantage of

considering operad components $P(\mathbf{r})$ associated to all finite sets $\mathbf{r} = \{i_1, \dots, i_r\}$, so that we can deal with operations $p = p(x_{i_1}, \dots, x_{i_r})$ of r variables with arbitrary indexes. We explain this extension of the definition of an operad in the concluding section of the chapter §3.5.

We assume all through this chapter that we work within a base symmetric monoidal category \mathcal{M} . When we examine the application of categorical constructions to unitary operads in §§3.3-3.4, we will assume that the tensor product of this category satisfies the colimit preservation requirement §0.9(a), but until this moment, we do not use more than the general axioms of symmetric monoidal categories.

3.1. The partial composition product definition of operads

In the point-set context, the partial composition products of an operad are basically defined by formulas $p \circ_k q = p(1, \dots, 1, q, 1, \dots, 1)$, where $q \in P(n)$ is plugged in the k th input of the operation $p \in P(m)$, and operad units $1 \in P(1)$ are inserted at the other input positions. In §1.1.4, we observed that the unit and associativity axioms of operads imply that the full composition products of §1.1.1 satisfy $p(q_1, \dots, q_r) = (\dots (p \circ_{k_1+1} q_1) \circ_{k_2+1} \dots) \circ_{k_r+1} q_r$, for any $p \in P(r)$ and all $q_1 \in P(n_1), \dots, q_r \in P(n_r)$, where we set $k_i = n_1 + \dots + n_{i-1}$ for $i = 1, \dots, r$. This result still holds in a general categorical framework as we can obviously replace our point-wise relations by morphism identities. In any case, we obtain from this analysis that the composition structure of an operad is fully determined by giving the partial composition products $\circ_k : P(m) \otimes P(n) \rightarrow P(m+n-1)$, where $k = 1, \dots, m$. The purpose of this section is to specify relations on partial composition operations which are equivalent to the equivariance, unit, and associativity axioms of §1.1.1. The first outcome of this study, as we announced in the introduction of this chapter, is a new representation of the structure of an operad which will serve as working definition in subsequent constructions.

To start with, we give the formal definition, in categorical terms, of the partial composition operations.

3.1.1. *The partial composition products associated with an operad.* Let P be an operad (in the sense of the basic definition of §1.1.1). The partial composition operations associated to P

$$\circ_k : P(m) \otimes P(n) \rightarrow P(m+n-1)$$

are formally defined as composites

$$\begin{aligned} P(m) \otimes P(n) &\xleftarrow[(1)]{\cong} P(m) \otimes \mathbb{1} \otimes \dots \otimes P(n) \otimes \dots \otimes \mathbb{1} \\ &\xrightarrow[(2)]{ } P(m) \otimes P(1) \otimes \dots \otimes P(n) \otimes \dots \otimes P(1) \\ &\xrightarrow[(3)]{\mu} P(m+n-1), \end{aligned}$$

where we consider a tensor product of operad units $\eta : \mathbb{1} \rightarrow P(1)$, putting the factor $P(n)$ at the k th position of the tensor grouping $P(1) \otimes \dots \otimes P(n) \otimes \dots \otimes P(1)$, followed by the appropriate component of the full composition product of P . The range of definition of the full composition products in §1.1.1 implies that a partial composition operation of this form can be associated to any pair $m, n \in \mathbb{N}$ and each composition index $k \in \{1 < \dots < m\}$. (But, since the choice of composition index

is empty for $m = 0$, we may assume $m > 0$ when we apply partial composition operations.) In the point-set formalism, we just retrieve the formula $p \circ_k q = p(1, \dots, q, \dots, 1)$ recalled in the introduction of this section.

From this definition, we can already readily deduce the equivariance relations satisfied by the partial composition products:

PROPOSITION 3.1.2. *The equivariance axiom of operads, as expressed by the commutative diagram of Figure 1.4, implies that the partial composition operations of an operad P make the following diagram commute*

$$\begin{array}{ccc} P(m) \otimes P(n) & \xrightarrow{s \otimes t} & P(m) \otimes P(n) , \\ \circ_k \downarrow & & \downarrow \circ_{s(k)} \\ P(m+n-1) & \xrightarrow{s \circ_{s(k)} t} & P(m+n-1) \end{array}$$

for all $m, n \in \mathbb{N}$, each $k \in \{1 < \dots < m\}$, all $s \in \Sigma_m$, $t \in \Sigma_n$, and where $s \circ_{s(k)} t \in \Sigma_{m+n-1}$ refers to a partial composite of the given permutations $s \in \Sigma_m$, $t \in \Sigma_n$, formed within the permutation operad.

PROOF. The equivariance relation of this proposition immediately follows from the equivariance axiom expressed by the commutative diagram of Figure 1.4, where we take $r = m$ and $n_1 = \dots = n_{s(k)-1} = 1$, $n_{s(k)} = n$, $n_{s(k)+1} = \dots = n_r = 1$.

Simply observe that the permutation $s(id, \dots, t, \dots, id)$, occurring in this application of the axiom, with t plugged in the $s(k)$ th composition position of s , defines the partial composite $s \circ_{s(k)} t$ of the permutations $s \in \Sigma_m$, $t \in \Sigma_n$. \square

Before going further, we review the definition of the operadic composition of permutations in order to give an explicit definition of the permutation $s \circ_{s(k)} t \in \Sigma_{m+n-1}$ occurring in the above proposition. The purpose of this examination is to illustrate the definition of partial composition operations. In the rest of this section, we only use formal properties attached to the partial composition of permutations, and not the explicit expression.

3.1.3. *Partial composites of permutations.* The permutation composite $s \circ_{s(k)} t \in \Sigma_{m+n-1}$ occurring in the previous proposition can be determined from the construction of the composition structure on permutations in §§1.1.7-1.1.9. Indeed, we simply have to unravel the definition of that permutation as a composite

$$s \circ_{s(k)} t = s(id_1, \dots, t, \dots, id_m) = id_1 \oplus \dots \oplus t \oplus \dots \oplus id_1 \cdot s(1, \dots, n, \dots, 1).$$

In the sequence representation of permutations (see §1.1.7), we readily see that the sequence associated with the composite $s \circ_{s(k)} t$ is defined by substituting the sequence associated with t to the occurrence of the composition index $s(k)$ in the sequence defining s , with the appropriate value shift reflecting the interpretation of partial composites in terms of a composition of operations (see §1.1.4). To be explicit, if we let $s = (s(1), \dots, s(m))$ and $t = (t(1), \dots, t(n))$, then the result of this substitution process has the form

$$s \circ_{s(k)} t = (s(1)', \dots, s(k-1)', t(1)', \dots, t(n)', s(k+1)', \dots, s(m)'),$$

where we set $s(i)' = s(i)$, when $s(i) < s(k)$, $s(i)' = s(i) + n - 1$, when $s(i) > s(k)$, and $t(j)' = t(j) + n - 1$ in all cases. For instance, for the permutations $s = (1, 3, 5, 4, 2) \in \Sigma_5$ and $t = (3, 1, 2) \in \Sigma_3$, we obtain $s \circ_4 t = (1, 3, 7, 6, 4, 5, 2)$.

3.1.4. *The graphical definition of the partial composition products.* In the graphical representation of §1.1.6, the definition of the partial composition operations from the full composition products reads:

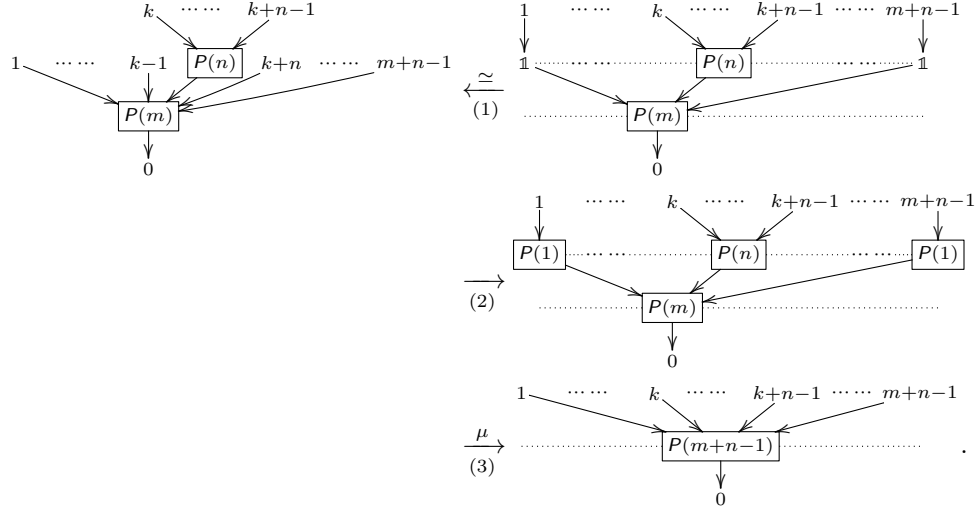

Recall (see §1.1.6) that an arrangement of operad components (or elements) on a tree represents a tensor product. The removal of unit factors $\mathbb{1}$ in isomorphism (1) corresponds to the application of the unit isomorphisms in the formal definition of §3.1.1, and morphisms (2-4) represent the continuation of the process. The withdrawal of the unit factors gives the composition pattern depicted on the source of isomorphism (1).

3.1.5. *The scheme of the partial composition operations, input indexing and equivariance.* In the point-set context, we may use the figure of §3.1.4 to represent the partial composition of operad elements $p \in P(m)$ and $q \in P(n)$. In the two-vertex tree defining the source of our composition morphism, we replace the operad components $P(m)$ and $P(n)$ by these corresponding elements $p \in P(m)$ and $q \in P(n)$. This figure gives the composition pattern underlying the composition operation $\circ_k : p \otimes q \mapsto p \circ_k q$.

In §3.1.4, we use the natural input indexing of the composite operation $p \circ_k q \in P(m+n-1)$ as a canonical input indexing attached to this composition pattern. In §1.1.5, we observed however that such canonical indexing may be changed into an arbitrary one in order to materialize the action of permutations on operadic composites. In the context of the partial composition operation, this extension of our tree-wise representation makes us deal with composition patterns of the following general form

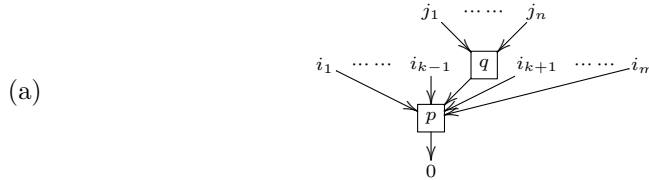

and which the performance of the partial composition operation $\circ_k : p \otimes q \mapsto p \circ_k q$ carries to the operad element represented by the following figure

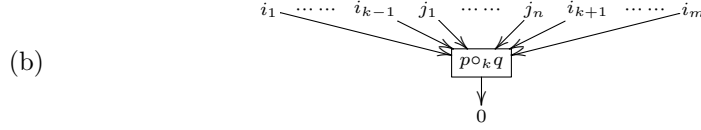

In §1.1.5, we also introduced relations to identify the action of permutations on operations with an input re-indexing of tree edges. In the case of the two-vertex tree (a), we deal with relations of the following form:

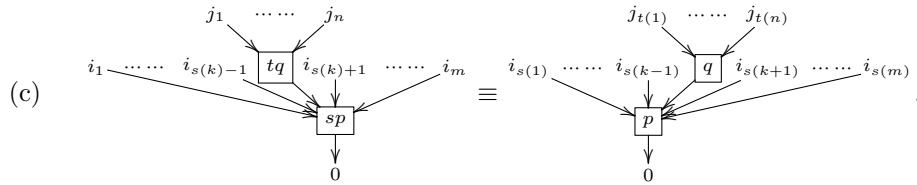

Recall that the ingoing edges of a box labeled by an operation $p \in P(r)$ are in bijection with the inputs of this operation. Moreover, as long as we deal with operad components associated to ordinals $\underline{r} = \{1 < \dots < r\}$, we assume that this bijection is realized by the ordering of the edges in the plane. Hence, the application of identification rules in the above picture moves the outgoing edge of $q \in P(n)$ from the $s(k)$ th position to the k th position in the ingoing edges of $p \in P(m)$.

The equivariance relation of Proposition 3.1.2 implies the coherence of the mapping (a) \mapsto (b), depicting the performance of a partial composition operation on tree-wise tensors, with respect to identifications (c). Indeed, this equivariance relation reads

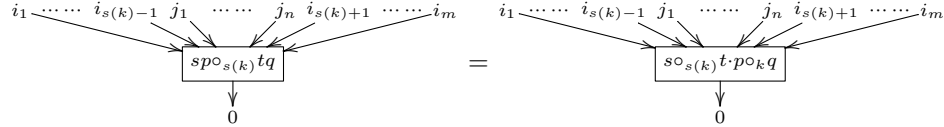

and we have the identification

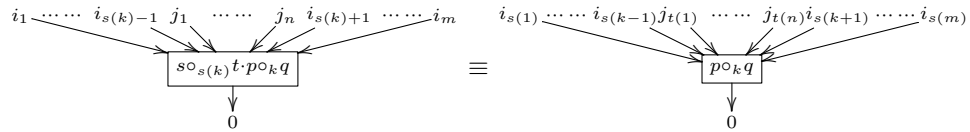

so that the map (a) \mapsto (b) equalizes both sides of relation (c).

The other way round, as soon as we deal with a mapping of the form (a) \mapsto (b), the preservation of identifications attached to tree-wise tensors implies the equivariance relation of partial composition products when we restrict ourselves to canonical indexing of the form considered in §3.1.4. Thus, whenever we use this picture, we implicitly consider partial composition operations satisfying the equivariance relation of Proposition 3.1.2.

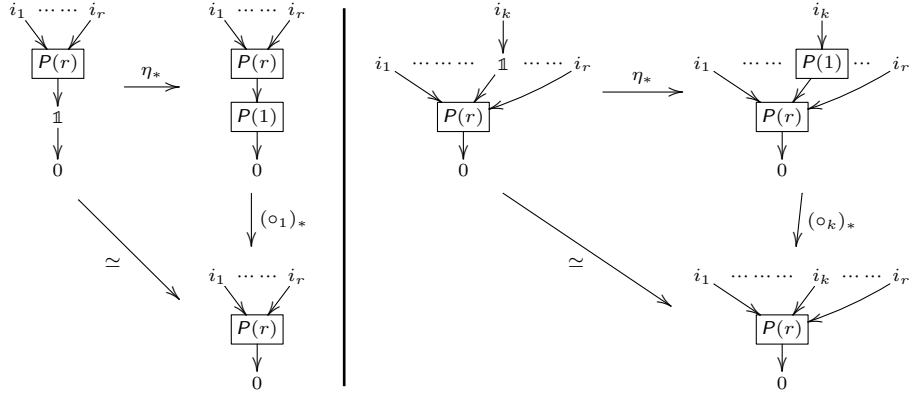
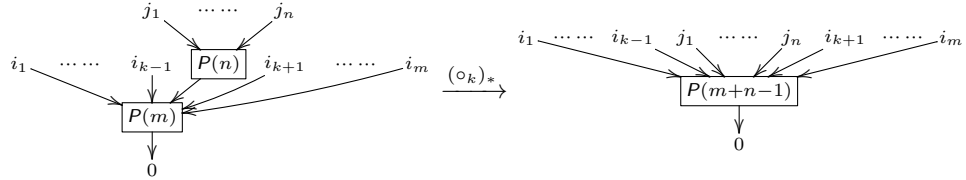

FIGURE 3.1. The unit relations of partial composition products, valid for all $r \in \mathbb{N}$ and $k = 1, \dots, r$.

3.1.6. *The graphical representation of the partial composition products of operads.* In general, we use the picture



to specify a partial composition product associated with an operad structure, and for which we implicitly assume that the equivariance relation of Proposition 3.1.2 is satisfied.

In this representation, we identify the application of the partial composition product \circ_k with the performance of an internal operation within the tree-wise tensor product. Thus, as in §1.1.6, we will use the notation $(\circ_k)_*$ to refer to the induced map on the global object which the tree-wise tensor, taken as a whole, represents. This internal operation has not to be confused with an external partial composition product, which we define in §II.A.2.7 and for which we use the notation \circ_{i_k} (without the $*$ mark, and with a tree input index i_k instead of an ingoing edge index k).

In §II.A, we elaborate of this picture of the partial composition operations to give a representation of the free operad. We roughly deal with composition schemes, modeled on trees with an arbitrary number of vertices, which represent multiple applications of partial composition products. We have already given an example of this representation in our introduction of free operad structures in §1.2. In Figure 3.1-3.3, we give fundamental examples of such (multi-fold) composition schemes, giving the shape of the unit and associativity relations satisfied by the partial composition operations.

The verification of these unit and associativity relations, from our initial definition of the composition structure of an operad in §1.1.1, is the subject of the following proposition:

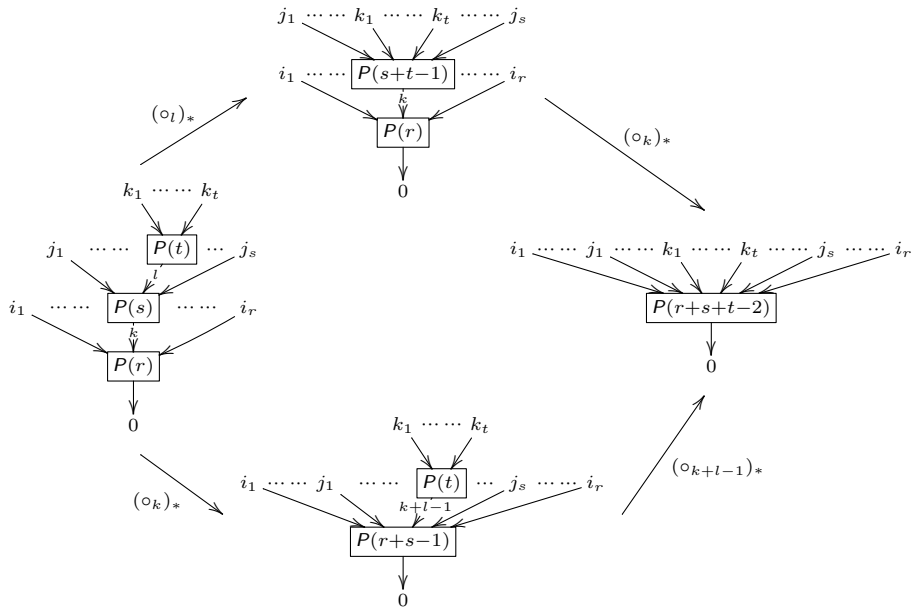

FIGURE 3.2. The associativity relation of partial composition products for a sequential arrangement of factors, with $r, s, t \in \mathbb{N}$, and $k \in \{1 < \dots < r\}$, $l \in \{1 < \dots < s\}$.

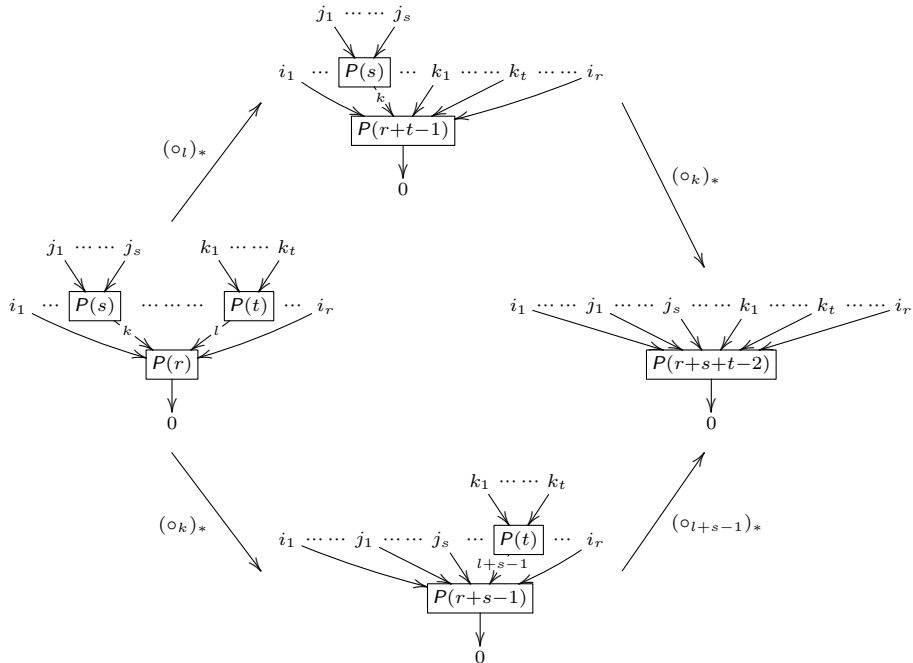

FIGURE 3.3. The associativity relation of partial composition products for a ramified arrangement of factors, with $r, s, t \in \mathbb{N}$, and $\{k < l\} \subset \{1 < \dots < r\}$.

PROPOSITION 3.1.7. *The partial composition operations*

$$\circ_k : P(m) \otimes P(n) \rightarrow P(m + n - 1), \quad k = 1, \dots, m,$$

defined from the full composition products of an operad in §3.1.1, fulfill unit and associativity relations expressed by the commutativity of the diagrams of Figure 3.1-3.3.

PROOF. To establish this proposition, we use the tree-wise interpretation of the full composition products of operads, and the corresponding representation of the unit and associativity axioms of operads in Figure 1.5-1.6

The unit relations of the proposition are immediate consequences of the unit axiom of full composition products, as expressed by the commutative diagrams of Figure 1.5. In one relation, we deal with a partial composite on an arity 1 component. But in this degenerate case, the partial composite is formally the same as a full composition product. In the other unit relation, the evaluation of the partial composition \circ_k simply amounts to distinguishing a tensor unit $\mathbb{1}$ in the composite $P(r) \otimes \mathbb{1}^{\otimes r} \rightarrow P(r) \otimes P(1)^{\otimes r} \xrightarrow{\mu} P(r)$ involving the full composition product.

The first associativity relation of partial composition products, expressed in Figure 3.2, is also immediate from the associativity axiom of the full composition products. Indeed, we simply have to apply the diagram of Figure 1.6 to a configuration of the form

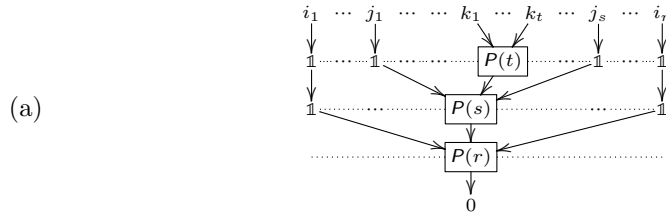

which, under the construction of partial composites in §§3.1.1-3.1.5, corresponds to the composition of partial composition operations represented in Figure 3.2.

In this process (and in the next constructions as well), the unit factors $\mathbb{1}$ correspond to the (delayed) application of unit morphisms $\eta : \mathbb{1} \rightarrow P(1)$. The unit axiom of Figure 1.5 implies that the evaluation of an operadic composite on a grouping of such unit factors is equal to the insertion of a unit morphism $\eta : \mathbb{1} \rightarrow P(1)$ at the place resulting from the composition operation. In our picture, we just keep unit factors at the positions associated with such groupings of operadic units.

To check the second associativity relation, we examine the associativity diagram of Figure 1.6 for configurations of the form

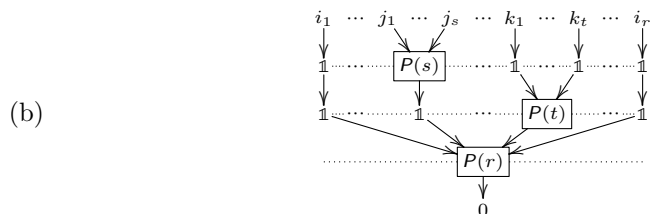

and

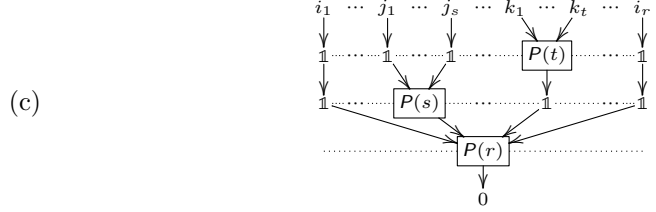

The definition of partial composites implies that the composites of partial composition operations represented in Figure 3.3 are identified with the composite composition products of (b-c), when the composition of the lower rows is performed first. On the other hand, if we perform the composition of the upper rows in (b-c), then we obtain in both cases a configuration of the form

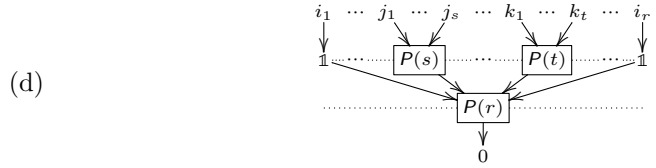

These composition operations reduce to the application of unit relations and form isomorphisms (b) $\xrightarrow{\cong}$ (d) $\xleftarrow{\cong}$ (c). From this identification, we deduce, by applying the associativity axiom of operads, that the composites of the partial composition operations of Figure 3.3 are both equal to a three-fold composition operation of the form

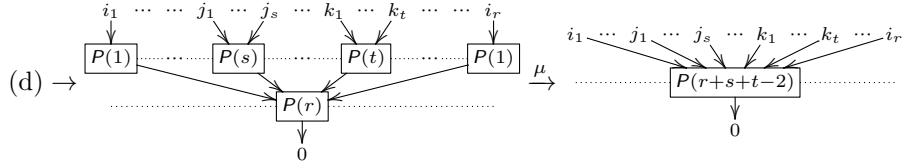

This identification finishes the proof of the proposition. □

3.1.8. *The definition of operads in terms of partial composition operations.* The result of Proposition 3.1.7 gives natural axioms for the definition of operadic structures in terms of partial composition products.

To be explicit, we call operad shaped on partial composition schemes the structure defined by a sequence of objects $P(n) \in \mathcal{M}$, $n \in \mathbb{N}$, where each $P(n)$ is equipped with an action of the symmetric group Σ_n (as in the definition of §1.1.1), together with:

- (a) a unit morphism $\eta : \mathbb{1} \rightarrow P(1)$,
- (b) and partial composition products $\circ_k : P(m) \otimes P(n) \rightarrow P(m + n - 1)$, defined for all $m, n \in \mathbb{N}$, and each $k \in \{1 < \dots < m\}$,

satisfying an equivariance relation, expressed by the commutativity of the diagram of Proposition 3.1.2 as well as unit and associativity relations, expressed by the commutativity of the diagrams of Figure 3.1, Figure 3.2, and Figure 3.3. Recall that we just use the equivariance relation when we form the tree-wise picture of the composition products occurring in these figures.

The definition of a connected operad in §1.1.21 has an obvious analogue for operads shaped on partial composition schemes. In this case, we forget about arity

zero components in our definition, and we set $P(1) = \mathbb{1}$. We then see that the partial composition operations (b) such that $m = 1$ or $n = 1$ are determined by the unit axioms of Figure 3.1. Hence, the composition structure of a connected operad shaped on partial composition schemes can be fully determined by partial composition products (b) such that $m, n > 1$.

The operads shaped on partial composition schemes form a category with, as morphisms, the morphisms of symmetric sequences $\phi : P \rightarrow Q$ preserving operadic units and the internal partial composition products of the operads. The result of Proposition 3.1.7 amounts to the definition of a functor, from the category of plain operads towards the category of operads shaped on partial composition schemes. Our claim is that:

THEOREM 3.1.9. *The category of operads shaped on partial composition schemes, as defined in §3.1.8, is isomorphic to the category of plain operads, as defined in §1.1.1. \square*

This result will be established in §II.A, where we explain a general formalism of tree-wise composition operations, which include the full composition products of §1.1.1 and the partial composition products considered in this section as particular examples.

3.1.10. *The point-wise formulation of the equivariance, unit, and associativity relations of partial composition products.* In general, we use the graphical picture to express the relations satisfied by the partial composition products of an operad. But we can easily give a point-wise representation of our relations whenever the notion of point-set element makes sense. First of all, the equivariance relation of partial composition products, stated in Proposition 3.1.2, is equivalent to the point-wise relation $sp \circ_{s(k)} tq = s \circ_{s(k)} t \cdot p \circ_k q$, for $p \in P(m)$, $q \in P(n)$, $s \in \Sigma_m$, $t \in \Sigma_n$, and $k = 1, \dots, m$. The unit relations, given by the diagrams of Figure 3.1, are equivalent to the formulas $1 \circ_1 p = p$ and $p \circ_k 1 = p$ for all $p \in P(r)$, and $k = 1, \dots, r$. The associativity relations, given by the diagrams of Figure 3.2-3.3, read $(a \circ_k b) \circ_{k+l-1} c = a \circ_k (b \circ_l c)$, respectively $(a \circ_k b) \circ_{s+l-1} c = (a \circ_l c) \circ_k b$, for $a \in P(r)$, $b \in P(s)$, $c \in P(t)$, and $k \in \{1 < \dots < r\}$, $l \in \{1 < \dots < s\}$, respectively $\{k < l\} \subset \{1 < \dots < r\}$.

3.2. The definition of unitary operads

In §1, we introduced the expression of unitary operad to refer to operads P_+ satisfying $P_+(0) = \mathbb{1}$. Recall that we also use the expression of non-unitary operad to refer to operads which have nothing in arity zero. In the case where the tensor product of the base category preserves colimits on each side §0.8(a), we can identify non-unitary operads with operads P such that $P(0) = \emptyset$. In general, we just forget about arity zero terms to formally define non-unitary operads, and for the moment, we can use this minimal approach for the definition of our notion.

The operad of unitary associative monoids As_+ , as defined in §1.1.16 (in the set-theoretic context), and the operad of unitary commutative monoids Com_+ are our basic examples of unitary operads. The operads As and Com , formed by dropping the arity 0 terms of these unitary operads, give basic instances of non-unitary operads.

Recall that we use the notation $\mathcal{O}p_1$ for the category formed by the unitary operads P_+ as objects and the operad morphisms $\phi : P_+ \rightarrow Q_+$ which are the

identity of $\mathbb{1}$ in arity 0 as morphisms, and we use the notation \mathcal{Op}_0 for category of non-unitary operads.

In §1.1.20, we introduced the expression of unitary extension to refer to the unitary operads P_+ which are defined by the addition of a unit term $P_+(0) = \mathbb{1}$ to a given non-unitary operad P . The main purpose of this section is to check that the composition structure of a unitary extension P_+ is determined by adding extra operations, reflecting the composition products with the additional unit term of the unitary extension, to the internal structure of the non-unitary operad P .

In the context of non-unitary operads, we mostly deal with the partial composition products, considered in the previous section, which form a good basis of generating operations for the composition structure. In the context of a unitary operad, we consider special operations, given by the composition products with the arity zero term $P_+(0) = \mathbb{1}$, which we prefer to regard as part of an extension of the internal symmetric structure of the operad and which we put apart from the composition structure therefore. The idea is that fixing $P_+(0) = \mathbb{1}$ transforms these composition products into additive operations, while the partial composition products are quadratic. This observation motivates the use of different approaches to address the underlying structures of unitary operads.

But we have to return to the analysis of the previous section in order to carry out our program. In a first stage, we study the subpart of the composition structure of a unitary operad consisting of these composition products which have the arity zero term $P_+(0) = \mathbb{1}$ and operadic units as single composition factors.

3.2.1. The restriction operations associated with a unitary operad structure.

We assume that P_+ is a unitary operad, such that $P_+(0) = \mathbb{1}$, and we use the notation P to refer to a non-unitary operad which agrees with P_+ in arity $n > 0$. We formally consider composite morphisms

$$\begin{aligned} P(n) &\xleftarrow{\cong} P_+(n) \otimes P_+(0) \otimes \cdots \otimes \mathbb{1} \otimes \cdots \otimes P_+(0) \otimes \cdots \otimes \mathbb{1} \otimes \cdots \otimes P_+(0) \\ &\xrightarrow{\eta_*} P_+(n) \otimes P_+(0) \otimes \cdots \otimes P_+(1) \otimes \cdots \otimes P_+(0) \otimes \cdots \otimes P_+(1) \otimes \cdots \otimes P_+(0) \\ &\xrightarrow{\mu} P_+(m), \end{aligned}$$

such that η_* is given by the application of operadic units $\eta : \mathbb{1} \rightarrow P_+(1)$ at places specified by an increasing sequence $1 \leq k_1 < \cdots < k_m \leq n$, and where μ denotes the appropriate component of the full composition products of the unitary operad P_+ . (We give a graphical representation of these composition schemes in §3.2.8.) Since specifying an increasing sequence $1 \leq k_1 < \cdots < k_m \leq n$ amounts to giving an increasing map $u : \{1 < \cdots < m\} \rightarrow \{1 < \cdots < n\}$ with $u(i) = k_i$, for $i = 1, \dots, m$, our construction returns a morphism $u^* : P_+(n) \rightarrow P_+(m)$ associated to any such map $u : \{1 < \cdots < m\} \rightarrow \{1 < \cdots < n\}$.

In the case $m, n > 0$, we more precisely obtain morphisms $u^* : P(n) \rightarrow P(m)$ between the components of the non-unitary operad P associated to P_+ . In the case $m = 0, n > 0$, we obtain an augmentation $\epsilon : P_+(n) \rightarrow \mathbb{1}$, defined on any component of the unitary operad P_+ , and which we also identify with a morphism $\epsilon : P(n) \rightarrow \mathbb{1}$ defined on the non-unitary operad P . In what follows, we generally use the expression of restriction morphism to refer to these structure morphisms associated with a unitary operad. In the point-set context, the restriction map $u^* : P(n) \rightarrow P(m)$ can be defined by a formula

$$u^*(p) = p(*, \dots, *, 1, *, \dots, *, \dots, *, 1, *, \dots, *),$$

for any $p \in P(n)$, where we use the notation $*$ to refer to the distinguished element of the operad P_+ in arity 0. The augmentation is similarly defined by $\epsilon(p) = p(*, \dots, *)$.

In the case where we take a single unitary factor $P_+(0) = \mathbb{1}$ in our construction of restriction morphisms, we retrieve the definition of a partial composition operation

$$P(n) \xleftarrow{\cong} P_+(n) \otimes P_+(0) \xrightarrow{\circ_k} P_+(n-1).$$

The restriction morphisms $\partial_k : P(n) \rightarrow P(n-1)$, $k = 1, \dots, n-1$, corresponding to these particular composites are associated with the increasing maps $\partial^k : \{1 < \dots < n-1\} \rightarrow \{1 < \dots < n\}$ jumping over a ~~single~~ value $k \in \{1 < \dots < n\}$. In the point-set context, the definition of these morphisms also reads $\partial_k(p) = p \circ_k *$, for any $k = 1, \dots, n$.

Since we observed in §3.1 that the full composition products of an operad are composites of partial restriction operations, we can readily conclude that all restriction morphisms associated with a unitary operad structure occur as composites of these particular restriction operations $\partial_k : P(n) \rightarrow P(n-1)$, $k = 1, \dots, n$. This assertion could equivalently be deduced from the observation that all increasing maps $u : \{1 < \dots < m\} \rightarrow \{1 < \dots < n\}$ are composites of maps of the form $\partial^k : \{1 < \dots < n-1\} \rightarrow \{1 < \dots < n\}$, and from the associativity of the action of restriction morphisms, which we will establish in Lemma 3.2.4.

3.2.2. *The category of ordinal injections.* Our first objective is to establish that the restriction operations $u^* : P(n) \rightarrow P(m)$ defined in the previous paragraph can be embodied in an extension of the internal symmetric structure of operads. For this purpose, we consider the category $\tilde{\Lambda}$ which has the finite ordinals $\underline{n} = \{1 < \dots < n\}$ with $n > 0$ as objects, and all injective maps $f : \{1 < \dots < m\} \rightarrow \{1 < \dots < n\}$ (not necessarily increasing) as morphisms. This category includes a distinguished subcategory $\tilde{\Lambda}^+ \subset \tilde{\Lambda}$ with the same objects as $\tilde{\Lambda}$, but of which morphisms reduce to the increasing maps of §3.2.1.

The tilde in our notation of the category $\tilde{\Lambda}$ refers to our restriction to ordinals $\underline{n} = \{1 < \dots < n\}$ such that $n > 0$. The notation Λ , when we refer to a category, is associated to the variant of the category $\tilde{\Lambda}$ where we consider all finite ordinals (including the empty one $\underline{0}$) as objects. Formally, we will not deal with that complete category Λ , but we generally use the associated notation Λ (with no extra decoration) as a qualifier for objects of which structure includes an action of morphisms $f \in \text{Mor}_\Lambda(\underline{m}, \underline{n})$. For instance, we will use the expression of non-unitary Λ -sequence to refer to the category of contravariant diagrams over the category $\tilde{\Lambda}$. In §3.4, we similarly use the expression of connected Λ -sequence to refer to a category of contravariant diagrams associated to another full subcategory $\tilde{\Lambda}$ of the category Λ .

In general, we also use the notation of the complete category Λ , rather than the notation of a specific full subcategory, in the expression of morphism sets. We adopt similar conventions for the sets of increasing maps which we associate to a subcategory of the complete category $\Lambda^+ \subset \Lambda$. We have the relation $\tilde{\Lambda}^+ = \tilde{\Lambda} \cap \Lambda^+$ for the non-unitary version $\tilde{\Lambda}^+$ which we consider all through this section.

In the sequel, we deal with objects of the category of $\tilde{\Lambda}^{op}$ -diagrams equipped with an augmentation over a constant diagram (see Proposition 3.2.6), which we associate to the commutative operad Com_+ (see §3.2.14). We will use the expression



of augmented non-unitary Λ -sequence to refer to the objects of this category, and we will adopt a similar naming in the connected context (see §3.4).

3.2.3. *The decomposition of morphisms in the category of ordinal injections.* The symmetric group Σ_n , $n > 0$, is identified with the automorphism group attached to the object \underline{n} in the category $\tilde{\Lambda}$. We readily see that any morphism $f \in \text{Mor}_{\Lambda}(\underline{m}, \underline{n})$ has a unique decomposition $f = \rho \cdot \sigma$, such that $\rho \in \text{Mor}_{\Lambda^+}(\underline{m}, \underline{n})$ and $\sigma \in \Sigma_m$. The map ρ is characterized by the relation $\{f(1), \dots, f(m)\} = \{\rho(1) < \dots < \rho(m)\}$, and the permutation $\sigma = (\sigma(1), \dots, \sigma(m))$ by the equation $\rho(\sigma(i)) = f(i)$, for any $i \in \underline{m}$.

In the particular case of a composite $f = s \cdot u$, where $u \in \text{Mor}_{\Lambda^+}(\underline{m}, \underline{n})$, and $s \in \Sigma_n$, the existence of our decomposition is equivalent to a commutation formula $s \cdot u = \rho \cdot \sigma$, where $\rho \in \text{Mor}_{\Lambda^+}(\underline{m}, \underline{n})$ and $\sigma \in \Sigma_m$ is a permutation associated to $s \in \Sigma_n$. This permutation $\sigma \in \Sigma_m$ is actually identified with the image of s under the restriction morphism ρ^* in the permutation operad, where we consider the increasing map ρ fitting in our decomposition $s \cdot u = \rho \cdot \sigma$. We give a proof of this identity in §3.2.7, where we go back to the definition of restriction operations for the example of the permutation operad.

In §1.2, we introduced the permutation category Σ with the ordinals $\underline{n} = \{1 < \dots < n\}$, $n \geq 0$, as objects, the permutation groups $\text{Mor}_{\Sigma}(\underline{n}, \underline{n}) = \Sigma_n$ as endomorphism sets, and such that $\text{Mor}_{\Sigma}(\underline{m}, \underline{n}) = \emptyset$, for $m \neq n$. In parallel to our category $\tilde{\Lambda}$, we consider the full subcategory of the permutation category $\tilde{\Sigma} \subset \Sigma$ generated by the ordinals $\underline{n} = \{1 < \dots < n\}$ such that $n > 0$, and which we can **obvious** identify with the isomorphism category associated to $\tilde{\Lambda}$. To refer to the decomposition $f = u \cdot s$ of the morphisms in the category $\tilde{\Lambda}$ we symbolically write $\tilde{\Lambda} = \tilde{\Lambda}^+ \cdot \tilde{\Sigma}$. The following lemma provides a first motivation for the introduction of our category $\tilde{\Lambda}$:

LEMMA 3.2.4. *Let P_+ be any unitary operad with P as underlying non-unitary operad.*

- (a) *The restriction morphisms $P(t) \xrightarrow{v^*} P(s) \xrightarrow{u^*} P(r)$ associated to any sequence of increasing maps $\{1 < \dots < r\} \xrightarrow{u} \{1 < \dots < s\} \xrightarrow{v} \{1 < \dots < t\}$ such that $r, s, t > 0$, satisfy the relation $u^*v^* = (vu)^*$ on $P(r)$.*
- (b) *The restriction morphisms $P(n) \xrightarrow{u^*} P(m)$ associated to increasing maps $\{1 < \dots < m\} \xrightarrow{u} \{1 < \dots < n\}$, with $m > 0$, also satisfy equivariance relations, expressed by the commutativity of the diagrams*

$$\begin{array}{ccc} P(n) & \xrightarrow{s} & P(n) \\ u^* \downarrow & & \downarrow \rho^* \\ P(m) & \xrightarrow{\sigma} & P(m) \end{array}$$

for all $s \in \Sigma_n$, where ρ denotes the increasing map and $\sigma \in \Sigma_m$ denotes the permutation fitting in the decomposition $f = \rho \cdot \sigma$ of the composite morphism $f = s \cdot u$ in $\text{Mor}_{\Lambda}(\underline{m}, \underline{n})$.

PROOF. The first assertion follows from an application the associativity relation of Figure 1.3 to the unitary operad P_+ , and the unit axiom of Figure 1.2, which we use to identify the composite $\mathbb{1} \otimes P_+(0) \xrightarrow{\eta \otimes id} P_+(1) \otimes P_+(0) \xrightarrow{\mu} P_+(0)$ with the canonical isomorphism $\mathbb{1} \otimes P_+(0) \xrightarrow{\cong} P_+(0)$. To be explicit, we consider

a composition pattern formed by three rows of operad components, with the single factor $P_+(t)$ on the lower row, and a t -fold (respectively, s -fold) tensor product of the form $P_+(0) \otimes \cdots \otimes \mathbb{1} \otimes \cdots \otimes P_+(0) \otimes \cdots \otimes \mathbb{1} \otimes \cdots \otimes P_+(0)$ on the second (respectively, third) row. The unit factors $\mathbb{1}$ are set at positions $v(1) < \cdots < v(s)$ (respectively, $u(1) < \cdots < u(r)$) on the second (respectively, third row) and are associated with operadic units $\eta : \mathbb{1} \rightarrow P_+(1)$ which we insert before applying our operadic composition products. We readily see that, for such a composition scheme, the commutativity of the diagram of Figure 1.3 gives the identity between the morphisms u^*v^* and $(vu)^*$ considered in our proposition.

The second assertion of the proposition is a consequence of the second equivariance axiom of Figure 1.1, where we take $n_k = 1$ if $k \in \{s(u(1)), \dots, s(u(m))\}$ and $n_k = 0$ otherwise. The permutation s^* moves the factors $P_+(1)$ in the tensor product $P_+(0) \otimes \cdots \otimes P_+(1) \otimes \cdots \otimes P_+(1) \otimes \cdots \otimes P_+(0)$ to the positions $1 \leq u(1) < \cdots < u(m) \leq n$. Hence, the composite $\mu \cdot id \otimes s^*$ occurring in our application of the equivariance axiom gives the restriction operation associated to u . On the other hand, the composition product $P_+(n) \otimes P_+(0) \otimes \cdots \otimes P_+(1) \otimes \cdots \otimes P_+(1) \otimes \cdots \otimes P_+(0) \xrightarrow{\mu} P_+(m)$ with the factors $P_+(1)$ at the initial positions $k \in \{s(u(1)), \dots, s(u(m))\}$ of our tensor product gives the restriction operation associated to the increasing map ρ such that $\{\rho(1) < \cdots < \rho(m)\} = \{s(u(1)), \dots, s(u(m))\}$. From the constructions of decompositions in §3.2.3, we immediately deduce that this map ρ is identified with the increasing map ρ such that $s \cdot u = \rho \cdot \Sigma_m$. Thus, the equivariance relation gives a commutative diagram of the form considered in our statement, but where σ denotes the block permutation $\sigma = s_*(0, \dots, 0, 1, 0, \dots, 0, \dots, 0, 1, 0, \dots, 0)$ associated to our lengths $n_k = 0, 1$.

The definition of §1.1.7 implies that this block permutation is represented by the sequence $(s(u(1))', \dots, s(u(m))')$, obtained by withdrawing the values $k \notin \{s(u(1)), \dots, s(u(m))\}$ from $(s(1), \dots, s(n))$, and where we perform an appropriate index shift, marked by the symbol $'$, to retrieve a permutation of $(1, \dots, m)$. The shift operation amounts to the formation of a sequence satisfying the relation $(\rho(s(u(1))'), \dots, \rho(s(u(m))')) = (s(u(1)), \dots, s(u(m)))$, because we can identify this reindexing process, where we just jump over the values $k \notin \{s(u(1)), \dots, s(u(m))\}$, with the application of an inverse of our increasing map ρ . This observation immediately implies that our block permutation is identified with the permutation σ fitting in the decomposition $su = \rho\sigma$ of the map $f = su$. \square

The following proposition is a consequence of Lemma 3.2.4:

PROPOSITION 3.2.5. *The underlying symmetric sequence of the non-unitary operad P associated with a unitary operad P_+ inherits the structure of a $\tilde{\Lambda}^{op}$ -diagram, so that the restriction morphisms of §3.2.1 give the action of the subcategory $\tilde{\Lambda}^+ \subset \tilde{\Lambda}$ on P and the natural symmetric structure of the operad corresponds to the action of the isomorphism subcategory $\tilde{\Sigma} \subset \tilde{\Lambda}$.*

In §3.2.2, we introduced the expression of non-unitary Λ -sequence as another naming for the $\tilde{\Lambda}^{op}$ -diagram structures occurring in this proposition. In the next section and later on, we use this expression, rather than the general categorical conventions, to stress the parallelism between the action of restriction morphisms and the symmetric sequence structures associated with plain operads.

EXPLANATIONS. To obtain the contravariant action $s^* : P(n) \rightarrow P(n)$ of a permutation $s \in \Sigma_n$ within the category $\tilde{\Lambda}$, we precisely consider the action of the permutation $s^{-1} : P(n) \rightarrow P(n)$, inverse to s , in the natural symmetric structure of the operad. The inversion operation enables us to retrieve a contravariant action, as required, from the natural left action of the symmetric group Σ_n on $P(n)$.

In general, the morphism $f^* : P(n) \rightarrow P(m)$ associated to a map $f \in \text{Mor}_{\Lambda}(\underline{m}, \underline{n})$ such that $f = u \cdot s$, where $u \in \text{Mor}_{\Lambda^+}(\underline{m}, \underline{n})$ and $s \in \Sigma_m$, is explicitly defined by the composite

$$P(n) \xrightarrow{u^*} P(m) \xrightarrow{s^{-1}} P(m),$$

where we take the restriction operation associated to u , followed by the action of the inverse of the permutation s on P .

We obviously have $id^* = id$ for the action of identity morphisms and the associativity relation of the action $f^*g^* = (gf)^*$ for general morphisms of the category $\tilde{\Lambda}$ is an immediate consequence of the results of Lemma 3.2.4. \square

To complete our analysis of the structure on the underlying sequence of unitary operads, we give a categorical interpretation of the augmentations of §3.2.1:

PROPOSITION 3.2.6. *The augmentations $\epsilon : P(n) \rightarrow \mathbb{1}$, $n > 0$, deduced from the structure of a unitary operad P_+ define a morphism of $\tilde{\Lambda}^{op}$ -diagrams $\epsilon : P \rightarrow \text{Cst}$, from the underlying diagram of the non-unitary operad P towards the constant diagram such that $\text{Cst}(n) = \mathbb{1}$, for all $n > 0$.*

PROOF. We can easily check, by the same arguments as in the proof of the functoriality relation $u^*v^* = (vu)^*$ in Lemma 3.2.4, that the augmentations $\epsilon : P(n) \rightarrow \mathbb{1}$, $n > 0$, make commute each diagram

$$\begin{array}{ccc} P(n) & \xrightarrow{u^*} & P(m) \\ & \searrow \epsilon & \swarrow \epsilon \\ & & \mathbb{1} \end{array},$$

where we consider the restriction morphisms associated to any map $u \in \text{Mor}_{\Lambda^+}(\underline{m}, \underline{n})$. We similarly immediately see, from the equivariance axiom of §1.1.1, that the augmentation $\epsilon : P(n) \rightarrow \mathbb{1}$ carries the action of a permutation $s \in \Sigma_n$ on $P(n)$ to the identity of the operad term $P_+(0) = \mathbb{1}$, and this verification completes the proof of our proposition. \square

In §3.2.14, we will observe that the constant diagram Cst is the $\tilde{\Lambda}^{op}$ -diagram underlying the commutative operad Com_+ . The augmentation morphism $\epsilon : P \rightarrow \text{Cst}$ can also be identified with a morphism towards this object Com . Therefore, we will use the notation of the commutative operad Com , rather than the notation of the constant object Cst , in subsequent applications of the result of the above proposition.

In the next section, we mostly use the expression of augmented non-unitary Λ -sequence, elaborating on the conventions introduced in §3.2.2, to refer to the $\tilde{\Lambda}^{op}$ -diagrams equipped with an augmentation over this constant object Cst .

3.2.7. *The example of the permutation operad.* In the case of the permutation operad, we can readily make explicit the restriction operations from the definition of the composition structure in §§1.1.7-1.1.9. Let $s \in \Sigma_n$. Let $u : \{1 < \dots < m\} \rightarrow \{1 < \dots < n\}$ be any increasing map. In the permutation operad, we have $*$ = $id_0 \in \Sigma_0$, $1 = id_1 \in \Sigma_1$, and the composite $u^*(s) = s(*, \dots, *, 1, *, \dots, *, \dots, *, 1, *, \dots, *)$ is given by the block permutation $s_*(0, \dots, 0, 1, 0, \dots, 0, \dots, 0, 1, 0, \dots, 0)$, where we apply the permutation s to blocks of length 1 at positions $1 \leq u(1) < \dots < u(m) \leq n$ specified by the injection, and blocks of length 0 on the remaining positions. This process amounts to a withdrawal of the terms $s(k) \notin \{u(1) < \dots < u(m)\}$, in the sequence representation of the permutation $s = (s(1), \dots, s(n))$, together with the performance of a natural index shift, carrying the set $\{u(1) < \dots < u(m)\}$ to $\{1 < \dots < m\}$, and which can formally be identified with the application of the mapping $u^{-1} : \{u(1) < \dots < u(m)\} \xrightarrow{\cong} \{1 < \dots < m\}$. converse to the given increasing map.

For instance, in the case of the map $u : \{1, 2, 3\} \rightarrow \{1, 2, 3, 4, 5\}$ such that $u(1) = 1, u(2) = 5, u(3) = 5$, and the permutation $s = (3, 1, 5, 2, 4)$, we perform the withdrawal operation $(3, 1, 5, 2, 4) \mapsto (1, 5, 4)$, followed by the normalization operation $(1, 5, 4) \mapsto (1, 3, 2)$, to get $u^*(3, 1, 5, 2, 4) = (1, 3, 2)$.

In §3.2.3, we mention that the permutation $\sigma \in \Sigma_m$ fitting in the decomposition $s \cdot u = \rho \cdot \sigma$, of the composite mapping $s \cdot u : \{1, \dots, m\} \rightarrow \{1, \dots, n\}$ is identified with the image of $s \in \Sigma_n$ under the restriction operation $\rho^* : \Sigma_n \rightarrow \Sigma_m$ associated with the increasing map ρ fitting in this decomposition. In Lemma 3.2.4, we only checked that our commutative diagram involves factors of the decomposition $s \cdot u = \rho \cdot \sigma$. (This result was enough to imply the conclusion of Proposition 3.2.5.) The identity $\sigma = \rho^*(s)$ actually follows from an application this equivariance relation to the identity permutation $id_n \in \Sigma_n$ within the permutation operad. Indeed, in this case, the equivariance relation reads $\sigma \cdot u^*(id_n) = \rho^*(s)$, from which we immediately deduce our identity $\sigma = \rho^*(s)$ since we obviously have $u^*(id_n) = id_m$ for the identity permutation $id_n \in \Sigma_n$.

By applying a similar argument to the inverse permutation s^{-1} , we also obtain that the permutation $u^*(s) \in \Sigma_m$ is determined by the equation $s^{-1} \cdot u = \rho \cdot u^*(s)^{-1}$ in the mapping set $\text{Mor}_\Lambda(\underline{m}, \underline{n})$, where ρ is the increasing map associated with that composite map $f = s^{-1} \cdot u$.

3.2.8. *The graphical definition of restriction morphisms.* We generally use the symbol $*$ to mark the positions of unitary factors $P_+(0) = \mathbb{1}$ in the picture of a restriction morphism. When we use this convention, the definition of the restriction morphisms from the full composition products of a unitary operad in §3.2.1 reads:

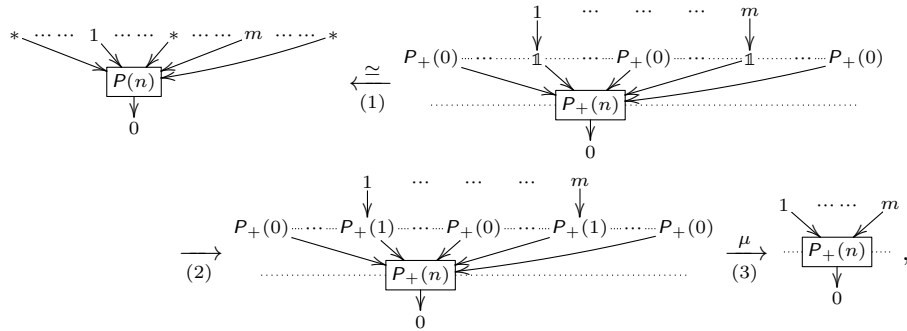

where (2) is the morphism η_* , considered in §3.2.1, given by the application of operadic units $\eta : \mathbb{1} \rightarrow P_+(1)$, and (3) is the full composition product of the operad P_+ .

3.2.9. *The graphical representation of restriction morphisms.* We can also elaborate on the conventions of §1.1.6 to give a graphical representation of our restriction morphisms. We then regard our morphisms as the performance of internal operations

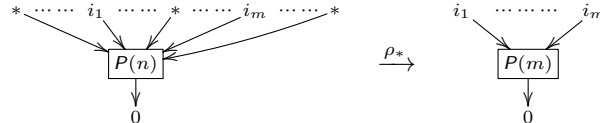

on tree-wise tensors. The expression ρ_* is a generic notation referring to the application of the restriction morphism u^* which we use in this tree-wise representation. The map $u : \{1 < \dots < m\} \rightarrow \{1 < \dots < n\}$ corresponding to this restriction morphism is just determined by the positions of the edges which, in our picture, are not marked by the symbol $*$.

In certain situations, we regard the application of the restriction morphism in the tree-wise picture as an identification relation between tree-wise tensors. This conception elaborates on the equivariance identities of §1.1.5.

We again use an arbitrary indexing of the inputs to materialize the action of permutations on our composition pattern. We can also elaborate on this convention to extend our representation to restriction morphisms $f^* : P(n) \rightarrow P(m)$ associated with any map $f : \{1, \dots, m\} \rightarrow \{1, \dots, n\}$ (possibly not monotone) in the category $\tilde{\Lambda}$. We then move the index i_k attached to an input $k = 1, \dots, m$ in the picture of the result of our operation, to the edge at position $f(k)$ on the source tree-wise tensor product, and we mark the remaining edges with the symbol of the unitary composite $*$, as in the increasing map case. We readily see that the permutation of the index positions (i_1, \dots, i_m) involved in this process corresponds to the action of the permutation s occurring in the decomposition $f = u \cdot s$ of our mapping. (We just perform an inversion of the correspondence of §1.1.5 to change the natural left action of the symmetric group on operads into a right action.) To give a simple example, for the mapping $f : \{1 < 2 < 3\} \rightarrow \{1 < 2 < 3 < 4 < 5\}$ such that $f(1) = 4, f(2) = 1, f(3) = 5$, the image of an element $p \in P(5)$ under the restriction operation $f^* : P(5) \rightarrow P(3)$ can be represented by the following picture

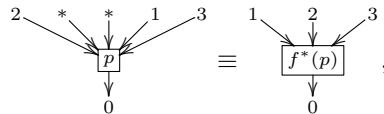

where we regard the performance of a restriction morphism as an identification of tree-wise tensors.

In what follows, we also deal with partial evaluations of our tree-wise restriction morphisms, allowing us to remove only a subpart of the distinguished ingoing edges $* \rightarrow \cdot$ in a given composition pattern. The associativity relation of Lemma 3.2.4 amounts to the assumption that the performance of such restriction processes in several stages does not change the result of the operation. The tree-wise restriction operations can be applied within tree-wise tensor products shaped on trees with several vertices. This natural extension of our picture is used in Proposition 3.2.11,

when we formulate an associativity relation between the restriction morphisms and the partial composition products of operads.

3.2.10. *The graphical representation of augmentations.* We adapt the conventions of the previous paragraph to represent the augmentations $\epsilon : P(n) \rightarrow \mathbb{1}$ associated with the structure of a unitary operad P_+ . To be precise, we may adopt the following picture

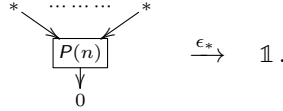

We use the notation ϵ_* , with an added lower script style $*$, to refer to this tree-wise morphism since, as usual, we regard this application of the augmentation on tree-wise tensors as the performance of an internal operation. We may again consider an obvious extension of the augmentation to tree-wise tensors shaped on trees with several vertices.

In §3.2.1, we focus on composition products of a unitary operad P_+ involving the arity zero term $P_+(0) = \mathbb{1}$ and operadic unit as composition factors. But we can still consider partial composition products $\circ_k : P_+(m) \otimes P_+(n) \rightarrow P_+(m+n-1)$, $k = 1, \dots, m$, defined by the composition scheme of §3.1.4. In the cases $m, n > 0$, which exclude the composites with the unitary factor $P_+(0) = \mathbb{1}$, these composition operations are identified with internal composition operations of the non-unitary operad underlying P_+ , and they satisfy the equivariance, unit, and associativity relations of §3.1 within this non-unitary operad.

To complete our results, we extend the analysis of §3.1 to determine associativity relations involving both our restriction morphisms and the partial composition products of §3.1. We regard these mixed associativity relations as part of an equivariance property of the partial composition products with respect to the action of category $\tilde{\Lambda}$ on the underlying collection and to the action of the augmentations. We therefore use this terminology in our statement and in the corresponding figures. The result reads:

PROPOSITION 3.2.11. *The partial composition products $\circ_k : P(m) \otimes P(n) \rightarrow P(m+n-1)$, $k = 1, \dots, m$, on the underlying non-unitary operad of a unitary operad P_+ , satisfy equivariance relations, expressed by the commutativity of the diagrams of Figure 3.5-3.4, with respect to the action of the restriction morphisms and of the augmentations on P .*



PROOF. This proposition follows from a simple variation of the arguments line of Proposition 3.1.7, where we establish the associativity relations of the partial composition products. Note that the result of the proposition holds for all restriction operations, not necessarily associated with an increasing map, and involves, in the general setting, the equivariance axiom of the composition products which we implicitly use when we form our picture of the associativity relation. \square

3.2.12. *The definition of unitary operads as extensions of non-unitary operads.* In §3.1, we established that the composition structure of an operad is determined by giving the partial composition products of §3.1.1. In the unitary context, we readily obtain from the analysis of the present section that the composition structure of a unitary extension P_+ of a non-unitary operad P can be determined by giving:

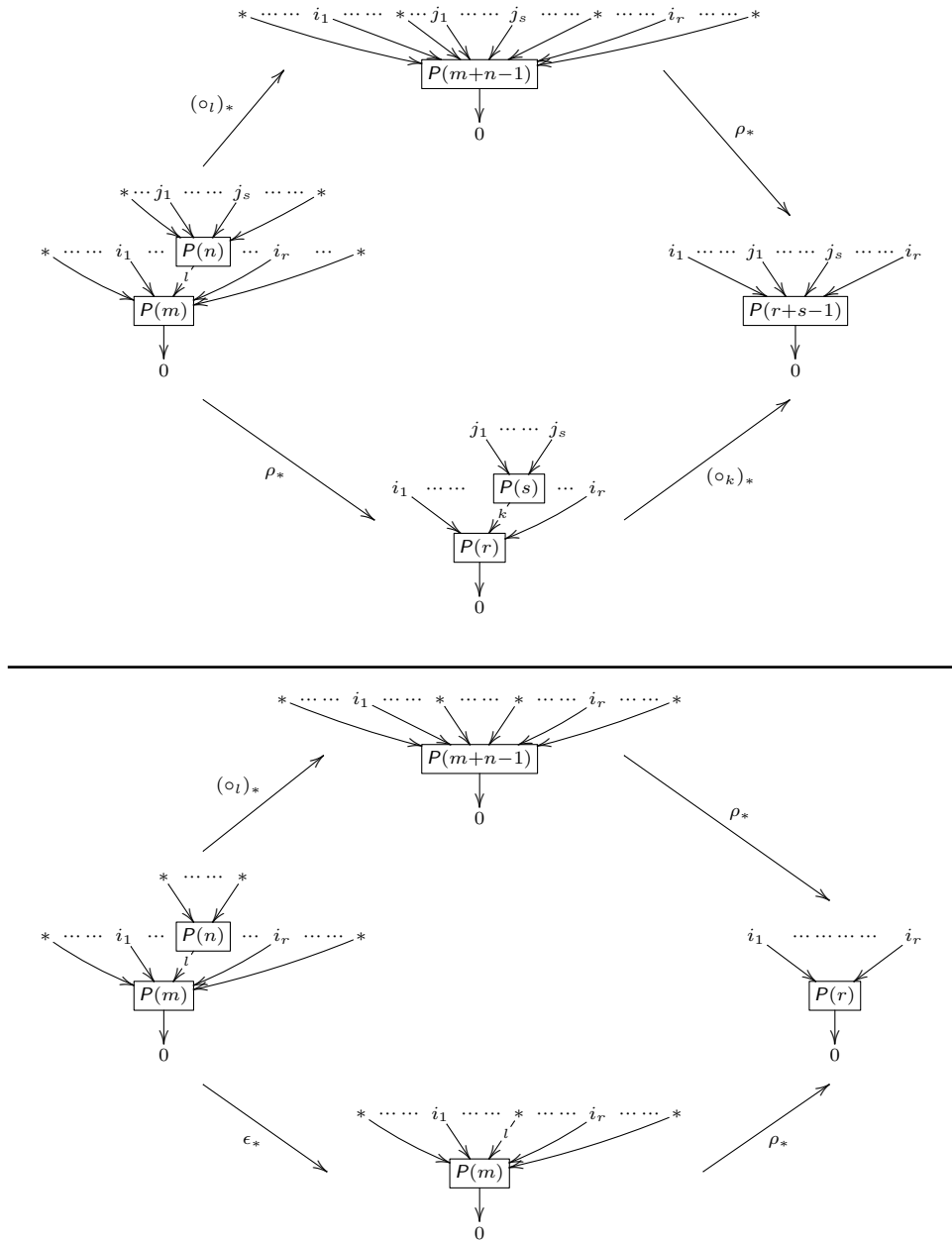

FIGURE 3.4. The equivariance of partial composition products with respect to the action of restriction morphisms.

(a) the internal partial composition products of the non-unitary operad P , which, in our unitary extension, correspond to the partial composition

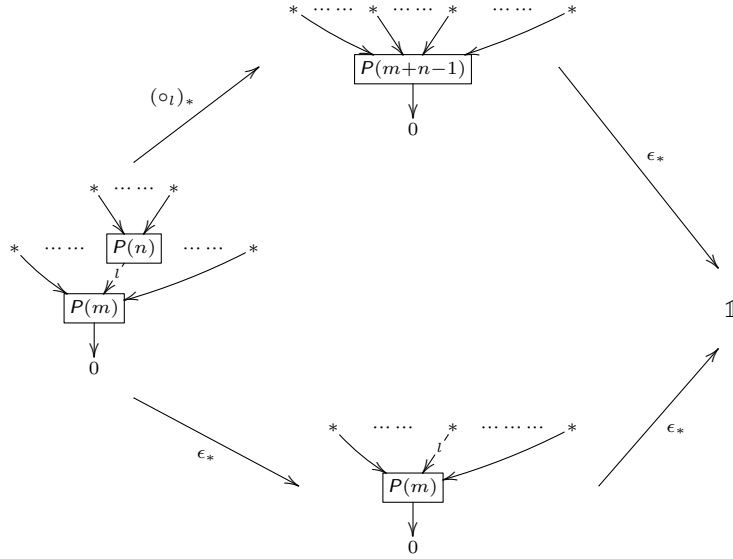

FIGURE 3.5. The preservation of partial composition products by augmentation morphisms.

product components

$$\underbrace{P_+(m) \otimes P_+(n)}_{=P(m) \otimes P(n)} \xrightarrow{\circ_k} \underbrace{P_+(m+n-1)}_{=P(m+n-1)}$$

such that $m, n > 0$,

- (b) the restriction morphisms $u^* : P(n) \rightarrow P(m)$, $m, n > 0$, $u \in \text{Mor}_{\Lambda^+}(\underline{m}, \underline{n})$, which are equivalent to composition operations of the form

$$\begin{aligned} & \underbrace{P_+(n) \otimes P_+(0) \otimes \cdots \otimes \mathbb{1} \otimes \cdots \otimes \mathbb{1} \otimes \cdots \otimes P_+(0)}_{=P(n)} \\ & \xrightarrow{\eta_*} P_+(m) \otimes P_+(0) \otimes \cdots \otimes P_+(1) \otimes \cdots \otimes P_+(1) \otimes \cdots \otimes P_+(0) \\ & \xrightarrow{\mu} \underbrace{P_+(m)}_{=P(m)}, \end{aligned}$$

with operadic units and unitary terms as composition factors,

- (c) and the augmentations $\epsilon : P(n) \rightarrow \mathbb{1}$, $n > 0$, which yield composition products

$$\underbrace{P_+(m) \otimes P_+(0) \otimes \cdots \otimes P_+(0)}_{=P(m)} \xrightarrow{\mu} \underbrace{P_+(0)}_{=\mathbb{1}}$$

with the unitary term $P_+(0) = \mathbb{1}$ as target.

Furthermore, by summarizing our results, we obtain that these structure morphisms satisfy the following requirements:

- the partial composition products (a) fulfill the equivariance, unit, and associativity axioms of §3.1.8, within the non-unitary operad;

- the restriction morphisms (b) and the augmentation (c) also satisfy equivariance and internal associativity relations, formulated in Lemma 3.2.4, so that (b-c) actually provide the underlying sequence of the non-unitary operad P with the structure of an augmented Λ -diagram (in the terminology of §3.2.2);
- the restriction morphisms (b) together with the augmentation (c) satisfy associativity relations with respect to the partial composition operations (a), which are expressed by the commutativity of the diagrams of Figure 3.4-3.5;
- and the unit axiom of operads §1.1(1.2) imply that the augmentation $\epsilon : P(1) \rightarrow \mathbb{1}$ in arity 1 defines a retraction of the operadic unit $\eta : \mathbb{1} \rightarrow P(1)$.

We coin the expression of augmented non-unitary Λ -operad to refer to the general structure defined a non-unitary operad P equipped with restriction morphisms (b) and augmentations (c) satisfying the above requirements. We also adopt the notation $\Lambda \mathcal{O}p_0 / \mathit{Com}$ for the category formed by these augmented non-unitary Λ -operads. We naturally define a morphism of augmented non-unitary Λ -operads as a morphisms of non-unitary operads that preserve the extra structure consisting of the restriction operations and the augmentations.

The results previously obtained in this section can be rephrased as the definition of a functor $\tau_+ : \mathcal{O}p_1 \rightarrow \Lambda \mathcal{O}p_0 / \mathit{Com}$ from the category of unitary operads $\mathcal{O}p_1$ towards the category of augmented non-unitary Λ -operad. We actually have the following stronger result:

THEOREM 3.2.13. *The correspondence of §3.2.12 provides an isomorphism between the category of unitary operads $\mathcal{O}p_1$ and the category of augmented non-unitary Λ -operads $\Lambda \mathcal{O}p_0 / \mathit{Com}$.*

PROOF. The applications of augmented non-unitary Λ -operads motivate our choice to introduce restriction operations as a new layer of structure, directly defined from the full composition products of §1.1.1, and lying over the partial composition products analyzed in the previous section. But we temporarily change our approach, and we rely on the result of the previous section, to give a formal proof of our statement.

In §3.2.1, we already observed that the restriction morphisms $u^* : P(n) \rightarrow P(m)$ include particular operations $\partial_k : P(n) \rightarrow P(n-1)$ corresponding to the partial composition products with a unitary factor $\circ_k : P_+(n) \otimes P_+(0) \rightarrow P_+(n-1)$, where we assume $n > 1$, and we take any $k = 1, \dots, n$. The arity 1 augmentation $\epsilon : P(1) \rightarrow \mathbb{1}$ is also clearly identified with the unique partial composition product $\circ_1 : P_+(1) \otimes P_+(0) \rightarrow P_+(0)$, which has the unitary component as target and is not covered by this correspondence.

Thus the structure of an augmented non-unitary Λ -operad P include all partial composition products which have to associate to a unitary extension of that operad. The equivariance, unit and associativity requirements in the definition of an augmented non-unitary Λ -operad also include all equivariance, unit and associativity relations which these partial composition products have to satisfy within the unitary operad. From the result of Theorem 3.1.9, we therefore obtain that the structure of a unitary extension P_+ is fully determined by the augmented Λ -operad structure associated with the non-unitary operad P so that the mapping $\tau_+ : P_+ \mapsto P$ defines an isomorphism of categories $\tau_+ : \mathcal{O}p_1 \rightarrow \Lambda \mathcal{O}p_0 / \mathit{Com}$ as claimed in our theorem. \square

In §II.A.5, we put the definition of the composition structure of unitary operads in a more global perspective, by integrating the partial composition products, the restriction morphisms, and the augmentations in the general form of tree-wise composition operations.

The unitary commutative operad \mathbf{Com}_+ , defined in §1.1 in the set-theoretic context, and in §2.1 in the general setting of symmetric monoidal categories, provides a natural example of a unitary operad. To conclude this section, we give a characterization of this operad as a terminal object within the category of unitary operads. For this purpose, we elaborate on the definition of the augmentations in §3.2.1.

3.2.14. *The unitary structure of the commutative operad.* Recall that the operad \mathbf{Com}_+ is defined by the constant symmetric sequence, such that $\mathbf{Com}_+(n) = \mathbb{1}$, for all $n \in \mathbb{N}$, and has all structure morphisms given either by the identity of the unit object $\mathbb{1}$, or by natural isomorphisms $\mathbb{1} \otimes \cdots \otimes \mathbb{1} \simeq \mathbb{1}$ arising from the unit constraint in the ambient symmetric monoidal category.

The restriction morphisms of the non-unitary operad \mathbf{Com} are therefore given by identity morphisms of the unit object, and, in the result of Proposition 3.2.5, we obtain that \mathbf{Com} inherits a constant $\tilde{\Lambda}^{op}$ -diagram structure (in arity $n > 0$). The augmentations $\epsilon : \mathbf{Com}(n) \rightarrow \mathbb{1}$ associated with this operad are also given by the identity of the unit object.

In Proposition 3.2.6, we prove that the $\tilde{\Lambda}^{op}$ -diagram defined by the collection $P(n) = P_+(n)$, $n > 0$, underlying a unitary operad P_+ is canonically augmented over this constant diagram. In fact, at the operad level, we have the following result:

PROPOSITION 3.2.15. *The augmentations $\epsilon : P_+(n) \rightarrow \mathbb{1}$, which we define by considering the components $P_+(n) = P_+(n) \otimes P_+(0)^{\otimes n} \xrightarrow{\mu} P_+(0)$ of the composition products of a unitary operad P_+ in §3.2.1, form a morphism of unitary operads $\epsilon : P_+ \rightarrow \mathbf{Com}_+$.*

PROOF. The equivariance, unit, and associativity axioms of operads, as formulated in the definition of §1.1.1, imply that the augmentations $\epsilon : P_+(n) \rightarrow \mathbb{1}$ carry all structure morphisms associated with the unitary operad P_+ to the identity of the unit object $\mathbb{1}$. We immediately conclude that these augmentations define a morphism towards the commutative operad \mathbf{Com}_+ as asserted. \square

From this proposition, we readily conclude that:

PROPOSITION 3.2.16. *The unitary commutative operad \mathbf{Com}_+ , as defined in §2.1, gives the terminal object of the category of unitary operads.* \square

3.2.17. *Free algebras over unitary operads.* The operads considered in May's monograph [134] are actually unitary operads (called unital operads in that reference) in the category of topological spaces. We have already observed that, for an algebra over a unitary operad giving the arity 0 operation $\lambda : P_+(0) \rightarrow A$ amounts to fixing a unit element in A . When we deal with topological spaces, this unit element is identified with a base point naturally associated to the space A .

The action of the category of ordinal injections is used in this context to give a reduced version of the free P_+ -algebra functor on the category of pointed spaces. We now consider, to be more precise, the complete category Λ , which includes an empty ordinal $\mathbb{0}$, rather than the truncated category $\tilde{\Lambda}$, where this empty ordinal

is excluded. The (contravariant) action of the category Λ on the non-unitary P , which we consider all through this section, extends to a (contravariant) action of this category Λ on the unitary operad P_+ . The cartesian powers $X^{\times n}$, $n \in \mathbb{N}$, of a pointed space X inherits a Λ -diagram structure: to an injective map $f : \{1 < \dots < m\} \rightarrow \{1 < \dots < n\}$, defining a morphism in Λ , we associate the mapping $f_* : X^{\times m} \rightarrow X^{\times n}$ which assigns any $(x_1, \dots, x_m) \in X^{\times m}$ to the n -tuple (y_1, \dots, y_n) such that

$$y_j = \begin{cases} x_i, & \text{if } j = f(i), \text{ for some } i, \\ *, & \text{otherwise.} \end{cases}$$

We then form the coend

$$S_*(P_+, X) = \int^{\mathbf{n} \in \Lambda} P_+(n) \times X^{\times n}$$

to get a P_+ -algebra, naturally associated with X . Intuitively, the performance of this coend amounts to implementing identities

$$pf_*(x_1, \dots, x_m) = f^*p(x_1, \dots, x_m),$$

in the free algebra structures of §1.3. One can readily check that this reduced free operad functor $S_*(P_+) : X \mapsto S_*(P_+, X)$ gives a left adjoint of the reduced forgetful functor $\omega : \mathcal{P}_+ \rightarrow \mathcal{Top}_*$, which retains the base point, yielded by the arity 0 action $\lambda : P_+(0) \rightarrow A$, from the structure of a P_+ -algebra.

May's approximation theorem [134] deals with the reduced free algebras associated with the little n -cubes operads C_{n+} , $n \in \mathbb{N}$ (see §4.1). May's result precisely asserts that, when X is a connected space (and more generally, when X is group like), the free algebra $S_*(C_{n+}, X)$ is weakly-equivalent to the iterated loop spaces $\Omega^n \Sigma^n X$, where Ω^n refers to the n -fold loop space functor on pointed spaces, and Σ^n refers to the n -fold suspension. In this construction, which gives the starting point of the iterated loop space theory of [134], the little n -cubes operad C_{n+} can be replaced by any Λ -diagram weakly-equivalent to C_{n+} and satisfying some mild cofibrancy conditions with respect to the action of symmetric groups.

The most classical example, occurring in the case $n = 1$, is given by the associative (permutation) operad As_+ . In this case, the reduced free associative monoid, which our construction represents, can be identified with the construction $J(X)$ introduced by James in [92]. May's approximation theorem actually occurred as a generalization of a result established by James, in terms of the combinatorial construction $J(X)$. We go back to this subject, and give further references on iterated loop space theory, in §4.1. 

3.3. Categorical constructions for unitary operads

We now assume that the tensor product of the base category preserves colimits on each side §0.8(a), and we revisit the definition of the categorical constructions of §1.2 in the context of unitary operads.

Let P_+ be any unitary operad. By Proposition 3.2.5 and Proposition 3.2.6, the collection $P(n)$, $n > 0$, where we drop the arity zero term $P_+(0) = 1$, inherits the structure of a $\tilde{\Lambda}^{op}$ -diagram which is also augmented over the constant $\tilde{\Lambda}^{op}$ -diagram $Cst = Com$, underlying the unitary commutative operad Com_+ . Hence, the mapping $\omega_+ : P_+ \mapsto P$ actually gives a forgetful functor $\omega_+ : \mathcal{Op}_1 \rightarrow \Lambda Seq_0 / Com$

towards the category, denoted by $\Lambda \text{Seq}_0 / \text{Com}$, which has these augmented $\tilde{\Lambda}^{op}$ -diagrams as objects. Throughout this section, we rather use the expression of augmented non-unitary Λ -sequence to refer to the objects of this category (see §3.2.2).

Our first purpose is to define a version of free operads giving a left adjoint of this extended forgetful functor $\omega_+ : \mathcal{O}p_1 \rightarrow \Lambda \text{Seq}_0 / \text{Com}$. The technical construction of these free unitary operads is carried out in the following lemma:

LEMMA 3.3.1. *Let $M \in \Lambda \text{Seq}_0 / \text{Com}$. Let $\mathcal{O}(M)$ be the free (non-unitary) operad associated to the symmetric sequence underlying M , where we forget about the restriction morphisms and the augmentations.*

- (a) *This free (non-unitary) operad $\mathcal{O}(M)$ has a unique (unitary) extension $\mathcal{O}(M)_+$ determined by restriction morphisms $u^* : \mathcal{O}(M)(n) \rightarrow \mathcal{O}(M)(m)$, $u \in \text{Mor}_{\Lambda^+}(\underline{m}, \underline{n})$, and augmentations $\epsilon : \mathcal{O}(M)(n) \rightarrow \mathbb{1}$ that extend the corresponding structure morphisms, given with our object M , on the image of the universal morphism $\iota : M \rightarrow \mathcal{O}(M)$.*
- (b) *Let $f : M \rightarrow P$ be a morphism of augmented non-unitary Λ -sequences, which has the augmented non-unitary Λ -sequence underlying a unitary operad P_+ as codomain. The operad morphism $\phi_f : \mathcal{O}(M) \rightarrow P$ associated to f has a unitary extension $\phi_{f+} : \mathcal{O}(M)_+ \rightarrow P_+$ and therefore gives rise to a factorization of f in the category of unitary operads.*
- (c) *In our construction (a), the universal morphism $\iota : M \rightarrow \mathcal{O}(M)$, defining the unit of the free operad adjunction on non-unitary objects, forms a morphism in the category of augmented non-unitary Λ -sequences $\Lambda \text{Seq}_0 / \text{Com}$. In the converse direction, the application of construction (b) to the identity morphism of the operad P , provides a morphism of unitary operads $\lambda_+ : \mathcal{O}(P)_+ \rightarrow P_+$ extending the adjunction augmentation of the ordinary free operad $\lambda : \mathcal{O}(P) \rightarrow P$.*

EXPLANATIONS. We refer to the appendix part (§II.A.5) for the formal proof of this statement. At this stage, we can content ourselves with informal explanations. We explained in §1.2 that the free operad $\mathcal{O}(M)$ intuitively consists of formal composites of elements of the generating symmetric sequence M (in the point-set context), which we can represent by general tree-wise tensors.

We basically use the associativity relations of Proposition 3.2.11 to deduce the action of restriction morphisms on such formal composites from the internal structure of the symmetric sequence M . To illustrate our constructions, we consider the same formal composite $p = (1\ 5) \cdot (((x \circ_1 y) \circ_4 z) \circ_3 t)$ as in our introduction of the free operad (see §1.2). Recall that this element p is represented by the tree-wise picture

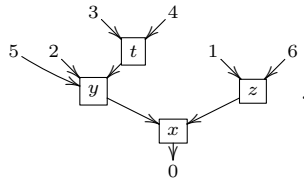

Let $u : \{1 < 2 < 3\} \rightarrow \{1 < 2 < 3 < 4 < 5 < 6\}$ be the map such that $u(1) = 1$, $u(2) = 2$, $u(3) = 5$. We use the conventions of §3.2.9 and we replace the input indices in the picture of the element p by the corresponding counter-image $u^{-1}(k)$ when $k \in \{u(1), u(2), u(3)\}$, by the unitary mark $*$ otherwise, in order to

represent the application of the restriction operation u^* on p :

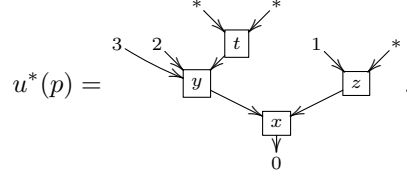

We assume that we work within a category of modules, so that the application of the augmentation $\epsilon : M(n) \rightarrow \mathbb{k}$ to an element $\xi \in M(n)$ returns a multiplicative scalar $\epsilon(\xi) \in \mathbb{k}$. We get the following reductions:

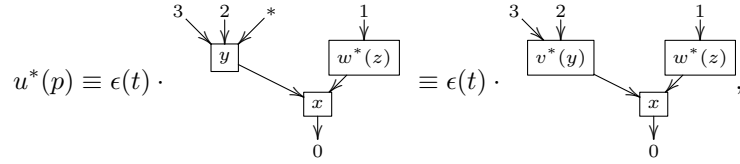

where $v^*(y)$ denotes the image of the element $y \in M(3)$ under the restriction morphism associated to the increasing map $v : \{1 < 2\} \rightarrow \{1 < 2 < 3\}$ such that $v(1) = 1$, $v(2) = 2$, and $w^*(z)$ denotes the image of the element $z \in M(2)$ under the restriction morphism associated to the increasing map $w : \{1\} \rightarrow \{1 < 2\}$ such that $w(1) = 1$.

We can use the same ideas in the case of the augmentation morphisms. We can equivalently determine the augmentation on the free operad as the unique operad morphism $\epsilon : \mathbb{O}(M) \rightarrow \mathit{Com}$ that extends the augmentation on M . But we have to go back to the explicit construction in order to check that this morphism carries the action of the restriction morphisms on the free operad $\mathbb{O}(M)$ to identity morphisms on Com .

We immediately obtain that the morphism $\phi_f : \mathbb{O}(M) \rightarrow P$ extending a morphism of augmented non-unitary Λ -sequences $f : M \rightarrow P$ in assertion (b) preserves restriction morphisms and augmentations, because we use universal relations, valid in any given unitary extension by Proposition 3.2.11, to define our structures on the free operad $\mathbb{O}(M)$. We deduce the conclusion of assertion (b) from this observation.

The claims of assertion (c) are tautological: in this concluding part of our statement, we just record some immediate consequences of the results obtained in (a-b). \square

We now check that:

THEOREM 3.3.2. *The construction of Lemma 3.3.1 provides a left adjoint*

$$\mathbb{O}(-)_+ : \Lambda \mathit{Seq}_0 / \mathit{Com} \rightarrow \mathcal{O}p_1$$

of our extended forgetful functor $\omega_+ : \mathcal{O}p_1 \rightarrow \Lambda \mathit{Seq}_0 / \mathit{Com}$ towards the category of augmented non-unitary Λ -sequences $\Lambda \mathit{Seq}_0 / \mathit{Com}$.

PROOF. This proposition is an immediate consequence of the claims of assertion (b-c) in Lemma 3.3.1. \square

The construction of Lemma 3.3.1 also implies that the unit morphism $\iota : M \rightarrow \mathbb{O}(M)$ associated with the free unitary operad adjunction is given by the adjunction unit attached to the free non-unitary operad. The claim of assertion (c) similarly implies that the adjunction augmentation $\lambda_+ : \mathbb{O}(P)_+ \rightarrow P_+$ is a unitary extension

of the basic adjunction augmentation $\lambda : \mathbb{O}(P) \rightarrow P$ attached to the free non-unitary operad $\mathbb{O}(-)$.

The unit operad I admits an obvious unitary extension I_+ , and we immediately see that this operad I_+ defines the initial object of the category of unitary operads. We can also readily check the following result, which parallels the statement of Proposition 1.2.4 in §1.2:

PROPOSITION 3.3.3.

- (a) *The extended forgetful functor $\omega_+ : \mathcal{O}p_1 \rightarrow \Lambda \text{Seq}_0 / \text{Com}$, from unitary operads to augmented non-unitary Λ -sequences, creates all small limits, the filtered colimits, as well as the coequalizers which are reflexive in the category of augmented non-unitary Λ -sequences.*
- (b) *The category of unitary operads admits coproducts too and, as a by-product, all small colimits.*

PROOF. Exercise: check that the arguments of §1.2.4 extends to the unitary context. The case of coproducts is reviewed in the proof of the next statement. \square

To complete our results, we study the image of limits and colimits under the truncation functor $\tau : P_+ \mapsto P$ from unitary operads to non-unitary operads. Recall that any unitary operad P_+ inherits an augmentation over the commutative operad Com_+ by Proposition 3.2.15. We shall consider, to be precise, the functor $\tau : \mathcal{O}p_1 \rightarrow \mathcal{O}p_0 / \text{Com}$ which retains the augmentation $\epsilon : P \rightarrow \text{Com}$ induced by this canonical morphism on the unitary operad P_+ . We have the following result:

PROPOSITION 3.3.4. *The functor $\tau : \mathcal{O}p_1 \rightarrow \mathcal{O}p_0 / \text{Com}$, from the category of unitary operads to the category of augmented non-unitary operads, creates limits and colimits.*

PROOF. The case of limits follows from the observation that the forgetful functor $\omega : \Lambda \text{Seq}_0 / \text{Com} \rightarrow \text{Seq}_0 / \text{Com}$ creates limits, because limits in all diagram categories are created term-wise, and from the results Proposition 1.2.4 and Proposition 3.3.3, asserting that limits in the category of unitary and non-unitary operads are created at the level of the underlying sequence of objects in the base category (see also Proposition 1.2.16).

We can check the case of filtered colimits and reflexive coequalizers by the same argument.

We can address the case of a coproduct $Q = \bigvee_{\alpha} P_{\alpha}$ by using the same realization, in terms of a reflexive coequalizer of free operads

$$\mathbb{O}(\coprod_{\alpha \in J} \mathbb{O}(P_{\alpha})) \begin{array}{c} \xleftarrow{s_0} \\ \xrightarrow[d_1]{d_0} \\ \xrightarrow{\hspace{1.5cm}} \end{array} \mathbb{O}(\coprod_{\alpha \in J} P_{\alpha}) \dashrightarrow Q,$$

as in the proof of Proposition 1.2.4. We assume that each P_{α} has a unitary extension. We obtain from Lemma 3.3.1 that the restriction morphisms (and the augmentation) of the operads P_{α} have a unique extension to $\mathbb{O}(\coprod_{\alpha \in J} P_{\alpha})$, giving a unitary extension of this free operad. We similarly have a unitary extension of the free operad $\mathbb{O}(\coprod_{\alpha \in J} \mathbb{O}(P_{\alpha}))$, and of the structure morphisms of our coequalizer diagram. We readily deduce that our coequalizer Q admits a unitary extension since we observed that the reflexive coequalizers are created termwise in all operadic categories, and this unitary extension represents the coproducts of the unitary extension

of the operads P_α . The uniqueness claim in the definition of the restriction morphisms on $\mathcal{O}(\coprod_{\alpha \in \mathcal{J}} P_\alpha)$ implies the uniqueness requirement in the colimit creation process.

We deduce the case of general colimits from coproducts and reflexive coequalizers (by using that all colimits can be obtained as a combination of these particular colimit constructions). \square

We use the result of this proposition in §II.3.4, where we address the definition of a model structure on unitary operads.

3.4. The definition of connected unitary operads

In the previous sections, we addressed the definition of unitary operads in a general context. But in applications, we often deal with operads satisfying connectedness conditions. We assume that the tensor product of our base category preserves colimits on each side §0.8(a) as in the previous section.

Recall that, under our conventions, a non-unitary operad P is connected if we have $P(1) = \mathbb{1}$ in addition to the defining condition $P(0) = \emptyset$ of the category of non-unitary operads. In the unitary setting, we say that P is connected when we have $P(1) = \mathbb{1}$ in addition to $P(0) = \mathbb{1}$ (see §§1.1.19-1.1.20). The connected unitary operads P_+ are obviously identified with the unitary extensions of the non-unitary operads P which are connected as non-unitary operads. The category isomorphism of Theorem 3.2.13, between unitary operads and augmented non-unitary Λ -operads, has, therefore, an obvious restriction to connected operads.

Recall that a symmetric sequence M is said to be connected when $M(0) = M(1) = \emptyset$. The category formed by these connected symmetric sequences is denoted by Seq_{00} . The category of connected non-unitary operads is denoted by \mathcal{Op}_{01} , and the category of connected unitary operads by \mathcal{Op}_{11} .

In Theorem 1.2.14, we have observed that the standard free operad functor $\mathcal{O}(-)$ gives a functor from the category of connected symmetric sequences towards the category of connected (non-unitary) operads. Furthermore, we have established that this functor is left adjoint of the augmentation ideal functor $\bar{\omega} : P \mapsto \bar{P}$ which maps a connected operad P to the symmetric sequence such that $\bar{P}(n) = \emptyset$, if $n = 0, 1$, and $\bar{P}(n) = P(n)$, otherwise. The definition of the unitary extension of free operads in §3.3 is not well suited for this connected version of the adjunction relation, because when we form the augmentation ideal of an operad \bar{P} , we discard the restriction morphisms $u^* : P(n) \rightarrow P(1)$ which have the unit component of the operad as target.

We aim to adapt the construction of §3.3 in order to get a reduced definition of free connected unitary operads. We first introduce a truncated version of the category $\tilde{\Lambda}$ in order to address the structures underlying the augmentation ideal of connected unitary operads.

3.4.1. The connected version of the category of ordinal injections. We basically consider the full subcategory of the category of ordinal injections $\tilde{\Lambda}$ generated by the ordinals $\underline{n} = \{1 < \dots < n\}$, such that $n > 1$. We use the notation $\bar{\Lambda}$ for this truncated category, and as in §3.2.2, the notation $\bar{\Lambda}^+$, with a + superscript mark, to refer to the subcategory of $\bar{\Lambda}$ which has the increasing maps as morphisms.

We also use the notation $\bar{\Sigma}$ for the isomorphism subcategory of $\bar{\Lambda}$, of which morphism sets $\text{Mor}_{\bar{\Sigma}}(\underline{m}, \underline{n})$ are identified with the symmetric group Σ_n if $m = n$,

with the empty set otherwise. We have obvious identities $\bar{\Lambda}^+ = \Lambda^+ \cap \bar{\Lambda}$ and $\bar{\Sigma} = \Sigma \cap \bar{\Lambda}$, as well as a decomposition $\bar{\Lambda} = \bar{\Sigma} \sqcup \bar{\Lambda}^+$ as in the case of the category $\tilde{\Lambda}$. Recall that we use the notation of the complete category Λ (respectively, Λ^+ , Σ) rather than the notation of a specific subcategory in the expression of morphism sets.



We call connected Λ -sequence the structure formed by a connected symmetric sequence M together with restriction morphisms $u^* : M(n) \rightarrow M(m)$, associated to any $u \in \text{Mor}_\Lambda(\underline{m}, \underline{n})$, $m, n > 1$, and so that the associativity and equivariance relations of Proposition 3.2.4 are fulfilled in M . We immediately see, as in Proposition 3.2.5, that giving this structure amounts to providing the sequence M with a contravariant action of the category $\bar{\Lambda}$, so that the restriction morphisms $u^* : M(n) \rightarrow M(m)$ give the action of the subcategory $\bar{\Lambda}^+$ on M and the internal symmetric structure of the collection $M(n)$ provides the action of the isomorphism subcategory $\bar{\Sigma} \subset \bar{\Lambda}$. We use the notation ΛSeq_{00} , elaborating on our previous conventions, for this category of diagrams.

3.4.2. *The underlying structure of the augmentation ideal of connected unitary operads.* We immediately obtain that the action of the category $\tilde{\Lambda}$ on the non-unitary truncation P of a unitary operad P_+ in Proposition 3.2.5 restricts to an action of the truncated category $\bar{\Lambda}$ on the augmentation ideal \bar{P} . We moreover have an augmentation morphism $\epsilon : \bar{P} \rightarrow \overline{\text{Com}}$, defined as a restriction of the augmentation morphism of Proposition 3.2.15, with the augmentation ideal of the commutative operad as codomain.

The mapping $\bar{\omega}_+ : P_+ \mapsto \bar{P}$ therefore gives a functor $\bar{\omega}_+ : \mathcal{Op}_{11} \rightarrow \Lambda \text{Seq}_{00} / \overline{\text{Com}}$ from the category of connected unitary operads \mathcal{Op}_{11} towards the category of augmented connected Λ -sequences $\Lambda \text{Seq}_{00} / \overline{\text{Com}}$, where we adopt conventions similar to §3.2.2 to refer to the category formed by the connected Λ -sequences $M \in \Lambda \text{Seq}_{00}$ which are augmented over $\overline{\text{Com}}$.

Let M be any object of this category $\Lambda \text{Seq}_{00} / \overline{\text{Com}}$. Let $\mathcal{O}(M)$ be the free non-unitary operad associated to the symmetric sequence underlying M . The assumption $M(0) = M(1) = \emptyset$ implies that this free operad is connected, so that $\mathcal{O}(M)(1) = \mathbb{1}$, with a unit morphism $\eta : \mathbb{1} \rightarrow \mathcal{O}(M)(1)$ given by the identity of the unit object.

We have the following lemma:

LEMMA 3.4.3.

- (a) *The free operad $\mathcal{O}(M)$ inherits restriction morphisms $u^* : \mathcal{O}(M)(n) \rightarrow \mathcal{O}(M)(m)$, associated to all increasing maps $u : \{1 < \dots < n\} \rightarrow \{1 < \dots < m\}$, where $n, m > 0$, and whose restriction to $M(n) \subset \mathcal{O}(M)(n)$ is defined by:*

*/m
/n*

- the augmentation

$$M(n) \xrightarrow{\epsilon} \mathbb{1} = \mathcal{O}(M)(1)$$

when $n > m = 1$,

- the internal restriction morphism attached to our object

$$M(n) \xrightarrow{u^*} M(m) \subset \mathcal{O}(M)(m)$$

when $n \geq m \geq 2$.

- (b) *The free operad $\mathbb{O}(M)$ also inherits augmentations $\epsilon : \mathbb{O}(M)(n) \rightarrow \mathbb{1}$, $n > 0$, whose restriction to $M(n) \subset \mathbb{O}(M)(n)$ is defined by the natural augmentation $\epsilon : M(n) \rightarrow \mathbb{1}$ given with our object M for any $n \geq 2$.*
- (c) *The restriction morphisms $u^* : \mathbb{O}(M)(n) \rightarrow \mathbb{O}(M)(m)$ and augmentations $\epsilon : \mathbb{O}(M)(n) \rightarrow \mathbb{1}$, whose existence is asserted in (a-b), provide the free operad $\mathbb{O}(M)$ with the structure of an augmented non-unitary Λ -operad. These structure morphisms are also uniquely determined by our extension conditions in (a-b), together with the equivariance, unit and associativity requirements of the definition of augmented non-unitary Λ -operads in §3.2.12.*

/n /m

EXPLANATIONS. We again give short explanations and refer to the appendix part (§II.A.5) for a formal proof of this statement. We also assume that we work in a category of modules.

We use the conditions of §3.2.12, as in the proof of Lemma 3.3.1, to determine the image of a tree-wise tensor $p \in \mathbb{O}(M)(n)$, representing a formal composite of generating elements, under a restriction operation. The main difference, stated in assertion (a), is that the application of a restriction operation associated to an injection $u : \{1\} \rightarrow \{1 < \dots < n\}$ on a generating factor $\xi \in M(n)$ within the free operad $\mathbb{O}(M)(n)$ produces a multiple of the operad unit $1 \in \mathbb{O}(M)(1)$, which we can reduce further in the outcome of our operation.

We go back to the example given in the verification of Lemma 3.3.1 to illustrate this process. We now obtain the following result:

$$\begin{aligned}
 u^*(p) = & \begin{array}{c} \begin{array}{c} * \quad * \\ \swarrow \quad \searrow \\ \boxed{t} \\ \swarrow \quad \searrow \\ \boxed{y} \quad \boxed{z} \\ \swarrow \quad \searrow \\ \boxed{x} \\ \downarrow \\ 0 \end{array} \\ \begin{array}{c} 3 \quad 2 \\ \swarrow \quad \searrow \\ \boxed{y} \end{array} \quad \begin{array}{c} 1 \\ \swarrow \\ \boxed{z} \end{array} \end{array} \\
 \equiv & \epsilon(t) \cdot \epsilon(z) \cdot \begin{array}{c} \begin{array}{c} 3 \quad 2 \quad * \\ \swarrow \quad \searrow \\ \boxed{y} \\ \swarrow \quad \searrow \\ \boxed{x} \\ \downarrow \\ 0 \end{array} \quad \begin{array}{c} 1 \\ \downarrow \\ 1 \end{array} \\
 \equiv & \epsilon(t) \cdot \epsilon(z) \cdot \begin{array}{c} \begin{array}{c} 3 \quad 2 \\ \swarrow \quad \searrow \\ \boxed{v^*(y)} \\ \swarrow \quad \searrow \\ \boxed{x} \\ \downarrow \\ 0 \end{array} \quad \begin{array}{c} 1 \\ \swarrow \\ 1 \end{array} ,
 \end{array}
 \end{aligned}$$

where $v^*(y)$ denotes the image of the element $y \in M(3)$ under the restriction morphism associated to the increasing map $v : \{1 < 2\} \rightarrow \{1 < 2 < 3\}$ such that $v(1) = 1$, $v(2) = 2$ (as in the verification of Lemma 3.3.1). We apply the augmentation $\epsilon : M(2) \rightarrow \mathbb{1}$ to both $z \in M(2)$ and $t \in M(2)$, but in order to produce a unitary factor in the first case, a multiple of the operadic unit 1 in the second case.

The definition of the augmentation morphism $\epsilon : \mathbb{O}(M) \rightarrow \mathit{Com}$ is the same as in the context of Lemma 3.3.1. □

The definition of the restriction morphisms $u^* : \mathbb{O}(M)(n) \rightarrow \mathbb{O}(M)(1)$ in assertion (a) of the lemma is forced by the unit requirement of §3.2.12, which implies that the augmentation $\epsilon : \mathbb{O}(M)(1) \rightarrow \mathbb{1}$ defines a retraction of the operadic unit, and the associativity of the augmentation with respect to restriction morphisms.

Indeed, since $\mathbb{O}(M)(1) = \mathbb{1}$, we have a commutative diagram

$$\begin{array}{ccc}
 M(n) & \xrightarrow{\iota} & \mathbb{O}(M)(n) \\
 & \searrow & \downarrow u^* \\
 & & \mathbb{O}(M)(1) \\
 & \swarrow & \xrightarrow{\epsilon} \mathbb{1} \\
 & \searrow & \xrightarrow{\epsilon} \mathbb{1}
 \end{array}$$

ϵ

giving our definition of the restriction morphism $u^* : \mathbb{O}(M)(n) \rightarrow \mathbb{O}(M)(1)$ on the image of the universal morphism $\iota : M(n) \rightarrow \mathbb{O}(M)(n)$. This observation gives the crux of the following lemma:

LEMMA 3.4.4. *Let $M \in \Lambda \text{Seq}_{00} / \overline{\text{Com}}$. Let $\mathbb{O}(M)$ be the free connected operad associated to the symmetric sequence underlying M .*

- (a) *This free connected non-unitary operad $\mathbb{O}(M)$ has a unique unitary extension $\mathbb{O}(M)_+$, determined by the restriction morphisms and augmentations of Lemma 3.4.3, and such that the unit morphism $\iota : M \rightarrow \overline{\mathbb{O}(M)}$, associated with the free connected operad adjunction of Theorem 1.2.14, defines a morphism in the category of augmented connected Λ -sequences.*
- (b) *Let $f : M \rightarrow \overline{P}$ be a morphism of augmented connected Λ -sequences towards the augmentation ideal of a unitary operad P_+ . The operad morphism $\phi_f : \mathbb{O}(M) \rightarrow P$ associated to f has a unitary extension $\phi_{f+} : \mathbb{O}(M)_+ \rightarrow P_+$ and therefore gives rise to a factorization of f in the category of unitary operads.*
- (c) *In our construction (a), the universal morphism $\iota : M \rightarrow \overline{\mathbb{O}(M)}$, defining the unit of the connected free operad adjunction of Theorem 1.2.14, forms a morphism in the category of augmented connected Λ -sequences $\Lambda \text{Seq}_0 / \text{Com}$. In the converse direction, the application of construction (b) to the identity morphism of the augmentation ideal of the operad P , provides a morphism of connected unitary operads $\lambda_+ : \mathbb{O}(\overline{P})_+ \rightarrow P_+$ extending the basic adjunction augmentation $\lambda : \mathbb{O}(\overline{P}) \rightarrow P$ which arises from the result of Theorem 1.2.14.*

EXPLANATIONS. We have already explained the definition of the restriction morphisms and augmentations of assertion (a) in the verification of Lemma 3.4.3. The uniqueness of this structure has also been established in that statement.

We deduce the definition of the unitary extension $\mathbb{O}(M)_+$ from these previously obtained results and the result of Theorem 3.2.13.

We immediately obtain, as in the verification of Lemma 3.3.1, that the morphism $\phi_f : \mathbb{O}(M) \rightarrow P$ extending a morphism of augmented connected Λ -sequences $f : M \rightarrow \overline{P}$ in assertion (b) preserves restriction morphisms and augmentations, because we define our structures on the free operad $\mathbb{O}(M)$ by using universal relations, valid in any unitary extension of a connected operad. We deduce the conclusion of assertion (b) from this observation, and the claims of assertion (c) are again corollaries of the results obtained in the previous assertions of the lemma (a-b). \square

We now check that:

THEOREM 3.4.5. *The construction of Lemma 3.4.4 provides a left adjoint*

$$\mathbb{O}(-)_+ : \Lambda \text{Seq}_{00} / \overline{\text{Com}} \rightarrow \mathcal{Op}_{11}$$

of the augmentation ideal functor $\bar{\omega}_+ : P_+ \mapsto \bar{P}$ on the category of unitary operad $P_+ \in \mathcal{O}p_{11}$ and where we use the observations of §3.4.2 to provide the image of an object under this functor with the structure of an augmented connected Λ -sequence.

PROOF. This proposition directly follows from the claims of Lemma 3.4.4. \square

The construction of Lemma 3.4.4 also implies that the unit morphism $\iota : M \rightarrow \bar{\mathcal{O}}(M)$ associated with this free connected unitary operad adjunction is given by the adjunction unit attached to the free non-unitary operad. The claim of assertion (c) in Lemma 3.4.4 similarly implies that the adjunction augmentation $\lambda_+ : \mathcal{O}(P)_+ \rightarrow P_+$ is a unitary extension of the basic adjunction augmentation $\lambda : \mathcal{O}(P) \rightarrow P$ attached to the free non-unitary operad $\mathcal{O}(-)$.

We observed in §1.2.15 that the category embedding $\iota : \mathcal{O}p_{01} \hookrightarrow \mathcal{O}p_0$ has an obvious right adjoint $\tau : \mathcal{O}p_0 \rightarrow \mathcal{O}p_{01}$, which maps a non-unitary operad $P \in \mathcal{O}p_0$ to the connected operad such that $\tau P(0) = \emptyset$, $\tau P(1) = \mathbb{1}$, and $\tau P(n) = P(n)$ for $n > 1$. We have an analogous construction in the unitary context, but we now need the category isomorphism of Theorem 3.2.13 to obtain our result:

PROPOSITION 3.4.6. *The category embedding $\iota : \Lambda \mathcal{O}p_{01} / \text{Com} \hookrightarrow \Lambda \mathcal{O}p_0 / \text{Com}$ has a right adjoint $\tau : \Lambda \mathcal{O}p_0 / \text{Com} \rightarrow \Lambda \mathcal{O}p_{01} / \text{Com}$, given by the same truncation operation as in §1.2.15 since the connected operad τP associated to some $P \in \mathcal{O}p$ inherits obvious restriction morphisms and augmentations when we assume $P \in \Lambda \mathcal{O}p_0 / \text{Com}$.*

By unitary extension, this right adjoint gives rise to a functor $\tau : \mathcal{O}p_1 \rightarrow \mathcal{O}p_{11}$, which is also a right adjoint of the embedding $\iota : \mathcal{O}p_{11} \hookrightarrow \mathcal{O}p_1$ at the level of unitary operad categories.

PROOF. This proposition follows from straightforward verifications. \square

We can use the result of this proposition to extend the adjunction relation of the free connected unitary operad of Theorem 3.4.5 to morphisms $\phi_{f+} : \mathcal{O}(M)_+ \rightarrow Q_+$ with any unitary operad (possibly not connected) as codomain. We can also apply this observation to the definition of morphisms on connected unitary operads given by a presentation by generators and relations (see §3.4.8).

The results established in Proposition 1.2.16 and in Proposition 3.3.4 admit the following corollary which summarizes the construction of limits and colimits in our operad subcategories:

PROPOSITION 3.4.7. *We have a commutative square of embedding and truncation functors*

$$\begin{array}{ccc} \mathcal{O}p_{11} & \xrightarrow{\iota} & \mathcal{O}p_1 \\ \tau_+ \downarrow & & \downarrow \tau_+ \\ \mathcal{O}p_{01} / \text{Com} & \xrightarrow{\iota} & \mathcal{O}p_0 / \text{Com} \xrightarrow{\iota} \mathcal{O}p / \text{Com} \end{array} ,$$

which all create limits and colimits. \square

We now specialize our study to operads in a module category $\mathcal{M} = \text{Mod}$. We explain in §1.2.9 that operads in module categories can be defined by generators and relations as quotients $P = \mathcal{O}(M) / \langle z^\alpha, \alpha \in \mathcal{J} \rangle$, where we consider an ideal $\langle z^\alpha, \alpha \in \mathcal{J} \rangle$ in a free operad $\mathcal{O}(M)$. We generally use this basic construction in the context of connected non-unitary operads. When we deal with connected

unitary operads, we usually elaborate on the result of Theorem 3.4.5 to obtain a reduced presentations of unitary operads. We proceed as follows.

3.4.8. *The definition of unitary operads by generators and relations.* We assume that M is an augmented connected Λ -sequence (in \mathbb{k} -modules). We apply the construction of Lemma 3.4.3 to provide the free operad associated to M with the structure of an augmented non-unitary Λ -operad.

Let $S = \langle z^\alpha, \alpha \in \mathcal{J} \rangle$ be an ideal generated by a collection of elements $z^\alpha \in S(n_\alpha)$ in this free operad $\mathbb{O}(M)$.

We assume that we have

$$(a) \quad \epsilon(z^\alpha) = 0$$

when we apply the augmentation $\epsilon : \mathbb{O}(M)(n_\alpha) \rightarrow \mathbb{k}$ to any $z^\alpha \in S(n_\alpha)$. We also assume that we have

$$(b) \quad u^*(z^\alpha) \equiv 0 \pmod{S(m)},$$

for all restriction morphisms $u^* : \mathbb{O}(M)(n) \rightarrow \mathbb{O}(M)(m)$ such that $n = n_\alpha$. When these conditions hold, we readily obtain, from the correspondence of §3.2.12 between augmentations, restriction morphisms and composition operations, that the symmetric sequence $\langle z^\alpha, \alpha \in \mathcal{J} \rangle$ forms an operadic ideal in the unitary extension of the free operad $\mathbb{O}(M)$. Therefore, we have a quotient unitary operad $\mathbb{O}(M)_+ / \langle z^\alpha, \alpha \in \mathcal{J} \rangle$ associated to our ideal, and we immediately check that this operad defines a unitary extension of the basic quotient operad $\mathbb{O}(M) / \langle z^\alpha, \alpha \in \mathcal{J} \rangle$, considered in the study of §1.2.9.

The morphisms of unitary operads $\bar{\phi}_{f+} : \mathbb{O}(M)_+ / \langle z^\alpha, \alpha \in \mathcal{J} \rangle \rightarrow \mathcal{Q}_+$ are clearly in bijection with the morphisms of augmented non-unitary Λ -operads $\phi_f : \mathbb{O}(M) \rightarrow \mathcal{Q}$ such that $\phi_f(z^\alpha) = 0$ for each generating element of the ideal $z^\alpha \in S(n_\alpha)$.

In applications, we can reduce the verification of our vanishing condition (b) to the restriction morphisms $\partial_k : \mathbb{O}(M)(n) \rightarrow \mathbb{O}(M)(n-1)$, $k = 1, \dots, n$, associated with the partial composition products $\partial_k(p) = p \circ_k *$ since we observed in §3.2.1 that all restriction morphisms on a unitary operad occur as composites of these particular restriction operations.

3.4.9. *Examples of unitary operads constructed by generators and relations.* We explain the application of the construction of §3.4.8 to the basic examples of unitary operads considered in §1.2.10, namely the associative operad \mathbf{As}_+ , and the commutative operad \mathbf{Com}_+ . We also address the definition of a unitary version of the Poisson operad \mathbf{Pois}_+ . We consider the case of the associative operad first.

Recall that $\mathbf{As} = \mathbb{O}(\mathbb{k}\mu(x_1, x_2) \oplus \mathbb{k}\mu(x_1, x_2)) / \langle \mu(\mu, 1) - \mu(1, \mu) \rangle$ for a generating symmetric sequence such that $M_{\mathbf{As}}(2) = \mathbb{k}\mu(x_1, x_2) \oplus \mathbb{k}\mu(x_1, x_2)$ and $M_{\mathbf{As}}(r) = 0$ for $r \neq 2$. Since $M_{\mathbf{As}}$ vanishes in arity $r > 2$, we only have to specify an augmentation $\epsilon : M_{\mathbf{As}}(2) \rightarrow \mathbb{k}$, in order to provide this symmetric sequence with the structure of an augmented Λ -sequence. We take $\epsilon(\mu) = 1$ to reflect the idempotence relations $\mu(e, e) = e$ for the unit element of an associative algebra. By applying the associativity of restriction morphisms with respect to operadic composition structures, we obtain $\partial_1(\mu(\mu, 1) - \mu(1, \mu)) = \mu(\mu(*, 1), 1) - \mu(1(*, \mu), \mu) = \mu - 1(\mu) = 0$ and similarly $\partial_2(\mu(\mu, 1) - \mu(1, \mu)) = \partial_3(\mu(\mu, 1) - \mu(1, \mu)) = 0$. Hence, the assumptions of §3.4.8 are fulfilled, so that the operad \mathbf{As} inherits restriction morphisms, and as a consequence, admits a unitary extension \mathbf{As}_+ satisfying $\mathbf{As}_+(0) = \mathbb{k}$ and $\mathbf{As}_+(r) = \mathbf{As}(r) = \mathbb{k}[\Sigma_r]$ for $r > 0$. This operad \mathbf{As}_+ is actually identified with

the image of the permutation operad under the functor $\mathbb{k}[-] : \mathit{SetOp} \rightarrow \mathit{ModOp}$ (see §2.1.5).

The case of the commutative operad is similar. We take the same expression as in the associative case for the value of the augmentation $\epsilon : M_{\mathit{Com}}(2) \rightarrow \mathbb{k}$ on the generating operation $\mu \in M_{\mathit{Com}}(2)$. We that the assumptions of §3.4.8 are also fulfilled for the commutative operad, which therefore admits a unitary extension Com_+ satisfying $\mathit{Com}_+(0) = \mathbb{k}$ and $\mathit{Com}_+(r) = \mathit{Com}(r) = \mathbb{k}$ for $r > 0$. This operad Com_+ is actually identified with the image of the one-point set operad under our functor $\mathbb{k}[-] : \mathit{SetOp} \rightarrow \mathit{ModOp}$ (see the concluding discussion of §2.1).

The unitary extension process can also be applied to the Poisson operad Pois . Recall that this operad has a generating symmetric sequence such that $M_{\mathit{Pois}}(2) = \mathbb{k}\mu(x_1, x_2) \oplus \mathbb{k}\lambda(x_1, x_2)$, where $\mu = \mu(x_1, x_2)$ represents a (symmetric) commutative product and $\lambda = \lambda(x_1, x_2)$ represents an (symmetric) Lie bracket. We take $\epsilon(\mu) = 1$ (as usual) and $\epsilon(\lambda) = 0$ to reflect standard unit relations associated with the structure of Poisson algebras. Actually, the vanishing of ϵ on λ is forced by the antisymmetry relation $(1\ 2) \cdot \lambda = -\lambda$ and the equivariance requirement of §3.2.1. Again, we can check that the generating relations of the Poisson operad (see §1.2.12) are canceled by the restriction morphisms, so that the operad Pois admits a unitary extension Pois_+ satisfying $\mathit{Pois}_+(0) = \mathbb{k}$ and $\mathit{Pois}_+(r) = \mathit{Pois}(r)$ for $r > 0$.

3.4.10. *Unitary Hopf operads.* The results obtained in this section and in the previous one make sense in any base category equipped with a tensor product preserving colimits on each side (see §0.9), and as such, can be applied without change within the category of augmented cocommutative coalgebras, in order to give a description of (connected) unitary Hopf operads.

On the other hand, we can also adapt the observations of §2.2 and regard (connected) unitary Hopf operads as augmented cocommutative coalgebras in the category of (connected) unitary operads. Indeed, the arity-wise tensor products $(P \boxtimes Q)(r) = P(r) \otimes Q(r)$, as defined in §2.2.3, clearly preserves the category of (connected) unitary operads.

Furthermore, we immediately see that the action of a restriction morphism u^* , associated to any increasing map u , on a tensor product of operads $P \boxtimes Q$ is simply given by the tensor product of the restriction morphisms determined by u on P and Q . The requirement that the restriction morphisms are morphisms in the base category of coalgebras also amounts to the assertion that the augmentation $\Delta : P \rightarrow \mathit{Com}_+$ and the diagonal $\Delta : P \rightarrow P \boxtimes P$ intertwine restriction morphisms. Similar observations hold for the augmentations, and we can therefore regard the (connected) non-unitary Hopf Λ -operads, which underlie our category of (connected) unitary Hopf operad structures, as augmented cocommutative coalgebras in the category of (connected) unitary operads in the base category.

Similarly, we can regard augmented Hopf Λ -sequences as augmented Λ -sequences in the category augmented cocommutative coalgebras, or as augmented cocommutative coalgebras in the category of augmented Λ -sequences in the base category.

The results of Proposition 2.2.10 and §3.4.8 can be combined to get a good definition of unitary Hopf operads by generators and relations. In this context, the input of our construction is an augmented connected Hopf Λ -sequence, combining the Hopf structures considered in Proposition 2.2.10, and the restriction structures of §3.2.1.

The associative operad As_+ , the commutative operad Com_+ , and the Poisson operad $Pois_+$, give examples of connected unitary Hopf operads which we can define by a presentation by generators and relations. In fact, we simply have to check that the augmentation morphisms defined in §3.4.9 preserve the coalgebra structure on the generating collection M_P of these operads $P = As, Com, Pois$ (see §§2.2.11-2.2.12) to conclude that each operad $P = As, Com, Pois$ has a unitary extension as Hopf operad.

3.5. Operads and symmetric collections

In the definition of §1.1, and in the definition of §3.1 similarly, we assume that the terms of an operad $P(r)$ are indexed by non-negative integers $r \in \mathbb{N}$. This choice amounts to considering that the elements of an operad (whenever the notion of element makes sense) represent operations with inputs indexed by finite ordinals $\underline{r} = \{1 < \dots < r\}$. In the graphical representation of §1.1.5 and §3.1.5, this input ordering is used to determine the planar arrangement of the ingoing edges of a box associated to an operation. In §1.1.6 (and in §3.1.5 similarly), we observed on the other hand that the operadic composition operations are left invariant when we perform a change of planar arrangement in our representation, and this motivates us to introduce an additional definition of the notion of an operad which reflects this invariance feature. For this aim, we use that any symmetric sequence, underlying the structure of an operad, extends to a functor on the category of finite sets and bijections between them.

These finite set extensions of operads intuitively amounts to considering operations $p = p(x_{i_1}, \dots, x_{i_r})$ with variables indexed by an arbitrary set $\underline{r} = \{i_1, \dots, i_r\}$ rather than by a fixed ordinal $\underline{r} = \{1 < \dots < r\}$ (see the introduction of the chapter). From this interpretation, we see that operations $p = p(x_{i_1}, \dots, x_{i_r})$ and $q = q(x_{j_1}, \dots, x_{j_s})$ have partial composites $p \circ_{i_k} q = p(x_{i_1}, \dots, q(x_{j_1}, \dots, x_{j_s}), \dots, x_{i_r})$ defined for any indexing element $i_k \in \{i_1, \dots, i_r\}$. The main purpose of this section is to reformulate the definition of an operad in terms of these finite set extension of the partial composition products, and to make precise the form of the equivariance, unit, and associativity axioms of operads in this setting. By the way, we will observe that the graphical representation of §§3.1.5-3.1.6 gives the picture of the partial composition operations shaped on finite sets: we simply have to forget the planar embedding of our figure.

To begin with, we give a formal definition of the extension of symmetric sequences to functors on the category of finite sets and bijections.

3.5.1. Symmetric collections. We denote by \mathcal{Bij} this category which has the finite sets as objects and the bijections as morphisms. We adopt the convention to denote a finite set, regarded as an object of \mathcal{Bij} , by an underlined sans serif letter \underline{r} . We use the italic letter $r = \text{card}(\underline{r})$ corresponding to our set \underline{r} to refer to the cardinal of this set. We may regard this cardinal either as a non-negative integer, or as an isomorphism class in the category of finite sets.

We call symmetric collection, or just collection, a functor $M : \mathcal{Bij} \rightarrow \mathcal{M}$ mapping any finite set $\underline{r} \in \mathcal{Bij}$ to an object in the base category $M(\underline{r}) \in \mathcal{M}$, and any bijection $u : \underline{r} \xrightarrow{\cong} \underline{s}$ to a morphism $u_* : M(\underline{r}) \rightarrow M(\underline{s})$. We may also use the expression of Σ -collection, which parallels the expression of Σ -sequence, for these structures. In general, we specify a symmetric collection M by the underlying collection of objects $\{M(\underline{r})\}$.

Naturally, a morphism of collections $f : M \rightarrow N$ is a collection of morphisms in the base category $f : M(\mathbf{r}) \rightarrow N(\mathbf{r})$, defined for each finite set \mathbf{r} , and commuting with the action of bijections. We generally use the notation $\mathcal{C}oll$ for the category formed by symmetric collections and their morphisms.

The category of finite sets $\mathcal{B}ij$ has a small skeleton with the standard ordinals $\mathbf{r} = \{1 < \dots < r\}$, $r \in \mathbb{N}$, as objects and the permutations w , viewed as bijections $w : \{1, \dots, r\} \xrightarrow{\cong} \{1, \dots, r\}$, as morphisms. The following proposition is a consequence of this fact:

PROPOSITION 3.5.2. *The category of symmetric collections $\mathcal{C}oll$ is equivalent to the category of symmetric sequence $\mathcal{S}eq$ considered in §1.2.*

CONSTRUCTION AND PROOF. In one direction, to a symmetric collection $M \in \mathcal{C}oll$, we associate the sequence $M(r) = M(\{1, \dots, r\})$, where we use the action of bijections $w : \{1, \dots, r\} \xrightarrow{\cong} \{1, \dots, r\}$ to define the action of the symmetric group Σ_r .

If the base category has small colimits, then we can use a general Kan extension process to obtain a functor in the converse direction, from symmetric sequences to symmetric collections, which provides a left adjoint of this canonical functor $\mathcal{C}oll \rightarrow \mathcal{S}eq$. Let $M(r)$, $r \in \mathbb{N}$, be any given symmetric sequence. We use the tensor product expression

$$M(\mathbf{r}) = \mathcal{B}ij(\{1, \dots, r\}, \mathbf{r}) \otimes_{\Sigma_r} M(r), \quad \text{where } r = \text{card}(\mathbf{r}),$$

to refer to this Kan extension process.

If the notion of element makes sense, then this relative tensor product can be defined as the set of pairs (u, ξ) , where $u \in \mathcal{B}ij(\{1, \dots, r\}, \mathbf{r})$, and $\xi \in M(r)$, quotiented by the relations $(us, \xi) \equiv (u, s\xi)$ identifying the action of permutations $s \in \Sigma_r$ by right translation on bijections $u \in \mathcal{B}ij(\{1, \dots, r\}, \mathbf{r})$ with the internal Σ_r -structure of $M(r)$. The verification that this mapping gives an inverse equivalence of the canonical functor $\mathcal{C}oll \rightarrow \mathcal{S}eq$ is straightforward. In a general context, we can replace the set of pairs (u, ξ) by a coproduct of copies of the object $M(r)$ indexed by the set $\mathcal{B}ij(\{1, \dots, r\}, \mathbf{r})$, and we perform an appropriate coequalizer construction to implement the identities $(us, \xi) \equiv (u, s\xi)$. Equivalently, our relative tensor product represents a coend over the category which has one object and the permutation group Σ_r as morphism sets.

In fact, the category equivalence of the proposition still holds when the base category has no colimits. To avoid the colimit operation, we pick a representative bijection $u_{\mathbf{r}} : \{1 < \dots < r\} \rightarrow \mathbf{r}$, for each finite set of cardinal r . We then set $M(\mathbf{r}) = M(r)$, and we define the morphism $f_* : M(\mathbf{r}) \rightarrow M(\mathbf{s})$ associated to any $f \in \mathcal{B}ij(\mathbf{r}, \mathbf{s})$ by the action of the composite bijection $u_{\mathbf{s}}^{-1} \cdot f \cdot u_{\mathbf{r}} : \{1 < \dots < r\} \rightarrow \{1 < \dots < r\}$, defining a permutation of $\{1 < \dots < r\}$, on the object $M(r)$. \square

In the case of the sequence of permutation groups $\Pi(r) = \Sigma_r$, the underlying symmetric sequence of the permutation operad (§§1.1.7-1.1.9), we have an identity $\Pi(\mathbf{r}) = \mathcal{B}ij(\{1, \dots, r\}, \mathbf{r})$.

In what follows, we often use that the bijection $u \in \mathcal{B}ij(\{1, \dots, r\}, \mathbf{r})$ occurring in the equivalence of Proposition 3.5.2, are equivalent to orderings $i_1 < \dots < i_r$ of the set \mathbf{r} . The k th term of such an ordering i_k gives the value of the corresponding bijection $u(k) = i_k$ on the k th term of the ordinal $\{1 < \dots < r\}$. Thus, in the case

of the permutation operad Π , we can identify the elements of $\Pi(\underline{r})$ with orderings of the unordered set \underline{r} .

3.5.3. *Back to the graphical representation of symmetric sequences.* The construction of the collection from a symmetric sequence in Proposition 3.5.2 is materialized by the labeled-box representation of operads in §1.1.5. Indeed, in the picture

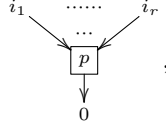

where p is any operad element, we can obviously assume that (i_1, \dots, i_r) are the elements of an arbitrary finite set, and not necessarily a permutation of $(1, \dots, r)$. The relation

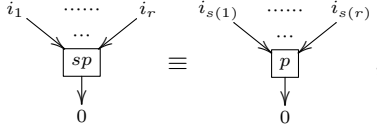

used to identify equivalent elements in the construction of §1.1.5, corresponds to the quotient process involved in the tensor product $\mathcal{B}ij(\{1, \dots, r\}, \underline{r}) \otimes_{\Sigma_r} P(r)$ (see the proof of Proposition 3.5.2). In §1.1.5, we only consider operads, but this interpretation of our construction obviously works for arbitrary symmetric sequences, not only the underlying symmetric sequences of operads.

3.5.4. *The graphical representation of symmetric collections.* The box representation, recalled in the previous paragraph, has a natural extension in the context of symmetric collections. In the picture §1.1.5, we use the planar arrangement of the ingoing edges of the box to materialize the bijection between the global inputs $\{i_1, \dots, i_r\}$ and the inputs of operad elements. Let us be more precise: our convention is to use the ordering, inherited from the ambient plane orientation, to get a canonical bijection between the set of ingoing edges $\{e_1, \dots, e_r\}$ and the finite ordinal $\{1 < \dots < r\}$ corresponding to the inputs of elements $p \in P(r)$. In the setting of symmetric collections, we just forget about the planar embedding to consider abstract trees, and we assume that ingoing edges form an abstract set $\{e_1, \dots, e_r\}$, not necessarily equipped with an ordering.

Suppose that we work within a category where the notion of element makes sense. Then we represent a collection element $\xi \in M(\underline{r})$ by a box labeled by ξ together with one outgoing edge e_0 , whose target is usually marked by the symbol 0 , and a set of ingoing edges $\{e_{i_1}, \dots, e_{i_r}\}$, whose source are usually marked by the elements of the indexing set $\underline{r} = \{i_1, \dots, i_r\}$, as in the following figure:

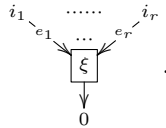

The edge set $\underline{e} = \{e_1, \dots, e_r\}$ may be distinguished from the external indexing set $\underline{r} = \{i_1, \dots, i_r\}$, and we assume that ξ belongs to $M(\underline{e})$. The edge indexing is equivalent to a bijection between $\underline{r} = \{i_1, \dots, i_r\}$ and the edge set $\underline{e} = \{e_1, \dots, e_r\}$. Thus, our representation formally amounts to giving a pair (s, ξ) , where $s : \underline{e} \xrightarrow{\cong} \underline{r}$ and $\xi \in M(\underline{e})$. The isomorphism $s_* : M(\underline{e}) \xrightarrow{\cong} M(\underline{r})$ induced by the bijection can

be used to associate an element of $M(\underline{r})$ to $\xi \in M(\underline{e})$. To make this correspondence faithful, we simply set $(su, \xi) \equiv (s, u_*(\xi))$ whenever we apply a bijection $u : \underline{e} \xrightarrow{\cong} \underline{f}$ to change the edge set. Graphically, this identity $(su, \xi) \equiv (s, u_*(\xi))$ reads:

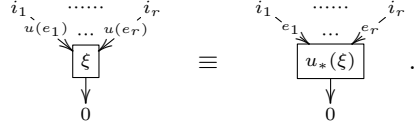

The natural action of bijections $v : \underline{r} \xrightarrow{\cong} \underline{s}$ corresponds, in the graphical representation, to the obvious reindexing operation on the input labels of ingoing edges.

Of course, the distinction between the indexing set \underline{r} and the actual input set \underline{e} amounts to considering overkilled information, which we simply reduce in our identification process. But in certain constructions (when we address the representation of composite operations for instance), we are naturally lead to mark such distinctions and to delay that reduction.

Naturally, we can apply our representation to objects and not only to elements. To be explicit, we set again $\underline{r} = \{i_1, \dots, i_r\}$ and $\underline{e} = \{e_1, \dots, e_r\}$. The picture

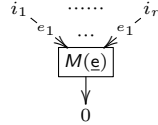

represents a copy of the object $M(\underline{e})$, which is naturally identified with $M(\underline{r})$ by applying the isomorphism $s_* : M(\underline{e}) \xrightarrow{\cong} M(\underline{r})$ induced by the bijection $s : \underline{e} \xrightarrow{\cong} \underline{r}$ such that $s(e_k) = i_k$, for $k = 1, \dots, r$.

3.5.5. *Operadic composition of finite sets.* To an operad P , we now associate a collection $P(\underline{r})$ indexed by the finite sets \underline{r} . Our next purpose is to give the representation of the composition structure of the operad in terms of this associated collection. The unit morphism of the operad P is obviously equivalent to a morphism $\eta : \underline{1} \rightarrow P(\underline{1})$, where we set $\underline{1} = \{1\}$. To go further, we need to introduce composition operations on finite sets. These finite set composites give the shape of the operadic composition structures which we aim to define.

Let $\underline{m} = \{i_1, \dots, i_m\}$. Let $\underline{n} = \{j_1, \dots, j_n\}$. For any $i_k \in \underline{m}$, we set

$$\underline{m} \circ_{i_k} \underline{n} = \{i_1, \dots, \widehat{i_k}, \dots, i_m\} \amalg \{j_1, \dots, j_n\}, \quad /m \ /n$$

where we use the notation $\widehat{i_k}$ to mark the removal of the element i_k from \underline{m} . To bijections $u : \underline{r} \xrightarrow{\cong} \underline{m}$, $v : \underline{s} \xrightarrow{\cong} \underline{n}$, and any $i_k \in \underline{r}$, we can associate a bijection, denoted by $u \circ_{u(i_k)} v : \underline{r} \circ_{i_k} \underline{s} \rightarrow \underline{m} \circ_{u(i_k)} \underline{n}$, given by u on $\{i_1, \dots, \widehat{i_k}, \dots, i_r\}$ and by v on $\{j_1, \dots, j_s\}$. Thus, this composition mapping on sets is in some sense equivariant with respect to the action of bijections.

Besides, we can readily check that the partial composition of finite sets fulfill set-theoretic analogues of the unit and associativity relations of §3.1. To be precise:

- (a) For any finite set \underline{s} , we have an identity $\underline{1} \circ_1 \underline{s} = \underline{s}$. For a finite set \underline{r} equipped with a distinguished element $i_k \in \underline{r}$, the set $\underline{r} \circ_{i_k} \underline{1}$ is not equal to \underline{r} in the strict sense, but we have an obvious bijection $\underline{r} \circ_{i_k} \underline{1} \simeq \underline{r}$ naturally associated to the pair (\underline{r}, i_k) .

(b) For a triple $(\underline{r}, \underline{s}, \underline{t})$, we have associativity identities

$$\begin{aligned} (\underline{r} \circ_{i_k} \underline{s}) \circ_{j_l} \underline{t} &= \underline{r} \circ_{i_k} (\underline{s} \circ_{j_l} \underline{t}), \\ (\underline{r} \circ_{i_k} \underline{s}) \circ_{i_l} \underline{t} &= (\underline{r} \circ_{i_l} \underline{t}) \circ_{i_k} \underline{s}, \end{aligned}$$

where $i_k \in \underline{r}$, $j_l \in \underline{s}$ in the first case, and $\{i_k \neq i_l\} \subset \underline{r}$ in the second case.

(c) The bijections of (a) are coherent with respect to the associativity relations of (b): any possible combination of a unit bijection $\underline{r} \circ_{i_k} \underline{1} \simeq \underline{r}$ with an associativity identity (in which we take a unit set $\underline{1}$ for one of the objects \underline{r} , \underline{s} , or \underline{t}) yields a diagram which commutes.

This is enough to formalize the definition of partial composition operation shaped on the composition of finite sets:

PROPOSITION 3.5.6. *The definition of morphisms*

(a)
$$P(m) \otimes P(n) \xrightarrow{\circ^k} P(m+n-1)$$

for all $m, n \in \mathbb{N}$ and $k = 1, \dots, m$, and such that the equivariance relation of Proposition 3.1.2 holds, amounts to the definition of morphisms

(b)
$$P(\underline{m}) \otimes P(\underline{n}) \xrightarrow{\circ_{i_k}} P(\underline{m} \circ_{i_k} \underline{n}),$$

for all finite sets $\underline{m}, \underline{n}$, and each $i_k \in \underline{m}$, so that the diagram

$$\begin{array}{ccc} P(\underline{r}) \otimes P(\underline{s}) & \xrightarrow{u_* \otimes v_*} & P(\underline{m}) \otimes P(\underline{n}) \\ \circ_{i_k} \downarrow & & \downarrow \circ_{u(i_k)} \\ P(\underline{r} \circ_{i_k} \underline{s}) & \xrightarrow{(u \circ_{u(i_k)} v)_*} & P(\underline{m} \circ_{u(i_k)} \underline{n}) \end{array}$$

commutes, for all bijections $u : \underline{r} \xrightarrow{\cong} \underline{m}$, $v : \underline{s} \xrightarrow{\cong} \underline{n}$.

The main purpose of this proposition is to make explicit the relationship between the plain partial composition operations (a) and the extended ones (b).

PROOF. For standard ordinals $\underline{m} = \{1 < \dots < m\}$ and $\underline{n} = \{1 < \dots < n\}$, we consider the bijection $\{1 < \dots < m\} \circ_{i_k} \{1 < \dots < n\} = \{1 < \dots < \widehat{i_k} < \dots, m\} \amalg \{1 < \dots < n\} \xrightarrow{\cong} \{1 < \dots < m+n-1\}$ mapping the interval $\{1 < \dots < i_k - 1\} \subset \{1 < \dots < \widehat{i_k} < \dots, m\}$ to the same interval $\{1 < \dots < i_k - 1\}$ in $\{1 < \dots < m+n-1\}$, the summand $\{1 < \dots < n\}$ to $\{i_k < \dots < i_k+n-1\}$ and the remaining elements $\{i_k + 1 < \dots < m\}$ of the summand $\{1 < \dots < \widehat{i_k} < \dots < m\}$ to $\{i_k + n < \dots < m+n-1\}$. The desired correspondence between our partial composition operations is deduced from the following diagram

$$\begin{array}{ccc} P(m) \otimes P(n) & \xrightarrow{\circ_{i_k}} & P(m+n-1) \\ \downarrow = & & \downarrow = \\ P(\{1, \dots, m\}) \otimes P(\{1, \dots, n\}) & \xrightarrow{\circ_{i_k}} & P(\{1, \dots, m\} \circ_{i_k} \{1, \dots, n\}) \\ & & \uparrow \simeq \\ & & P(\{1, \dots, m+n-1\}) \end{array} ,$$

which is supposed to commute.

This diagram enables us to get any collection of partial composition operations (a) from partial composition operations of the form (b) by identification. In the other direction, given finite sets \underline{m} and \underline{n} , we can pick bijections $\{1 < \dots < m\} \xrightarrow{\cong} \underline{m}$, $\{1 < \dots < n\} \xrightarrow{\cong} \underline{n}$, and use the equivariance diagram of the proposition to retrieve the partial composite (b) associated with the pair \underline{m} and \underline{n} from a partial composite of the form occurring in our diagram:

$$P(\{1 < \dots < m\}) \otimes P(\{1 < \dots < n\}) \xrightarrow{\circ_{i_k}} P(\{1 < \dots < m\} \circ_{i_k} \{1 < \dots < n\}).$$

This process makes the correspondence between partial composition operations of the form (a) and (b) fully explicit. In turn, the equivalence between the equivariance relations for (a) and (b) follows from straightforward verifications. \square

3.5.7. *The example of the permutation operad.* In the case of the permutation operad $\Pi(r) = \Sigma_r$, the elements of $\Pi(r)$ are identified with orderings $u = (i_1 < \dots < i_r)$ of the unordered set \underline{r} (see explanations below Proposition 3.5.2). We can use this representation to give a simple definition of the partial composition operations associated with this operad. We just describe the final result of this composition process again and leave the verification of our claim as an exercise for the readers.

In short, the sequence corresponding to the composite $u \circ_{i_k} v$ can be obtained by replacing the occurrence of the composition index i_k in the sequence representing u by the sequence representing v . For elements $u = (i_1 < \dots < i_m) \in \Pi(\underline{m})$ and $v = (j_1 < \dots < j_n) \in \Pi(\underline{n})$, we explicitly obtain a result of the form

$$u \circ_{i_k} v = (i_1 < \dots < i_{k-1} < j_1 < \dots < j_n < i_{k+1} < \dots < i_m).$$

In comparison with the process of §3.1.3, we simply have to forget the value shifts, which actually correspond to the bijection considered in the proof of Proposition 3.5.6.

3.5.8. *Operads with terms indexed by finite sets.* We can readily adapt the representation of §3.1.5 to get the picture of partial composition products in the context of operads with terms indexed by finite sets:

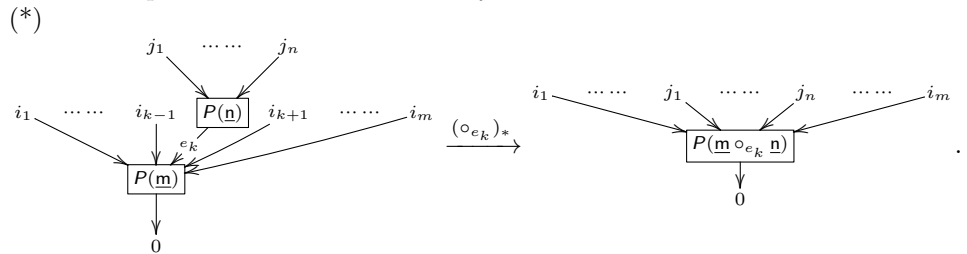

On the source of this mapping, we consider indexing sets \underline{m} and \underline{n} representing the sets of ingoing edges attached to each box of our tree-wise structure. The labeling of the tree inputs represent bijections $\{i_1, \dots, i_{k-1}, i_{k+1}, \dots, i_m\} \xrightarrow{\cong} \underline{m} \setminus \{e_k\}$ and $\{j_1, \dots, j_n\} \xrightarrow{\cong} \underline{n}$.

We readily see that these partial composites satisfy an obvious generalizations of the unit and associativity relations of §3.1. We simply have to insert the bijections of §3.5.5(a) when we apply the commutative diagrams of Figure 3.1, expressing our unit relation, to terms indexed by finite sets. Similarly, in the diagrams of Figure 3.2-3.3, expressing our associativity relation, we have to replace the ordinal

numbers $r + s - 1$, respectively $s + t - 1$, $r + t - 1$, $r + s + t - 2$, by appropriate finite set composites, using the associativity identities of §3.5.5(b).

We consider the general structures defined by the tree-wise composites (*) satisfying these finite set extension of the unit and associativity relations of operads as axioms. We deduce from Proposition 3.5.2 and Proposition 3.5.6 that this category of operads, with terms indexed by finite sets, is equivalent to the category of plain operads, with terms indexed by non-negative integers and a composition structure determined by partial composition products of the form considered in §3.1. We use the definition of operads with terms indexed by finite sets as working definition in §§II.A-B.

3.5.9. *Unitary operads with terms indexed by finite sets.* The constructions of §3.2, about the definition of unitary operads, can be extended to operads with terms indexed by finite sets. We then consider the category $\mathcal{J}nj$ formed by the non-empty finite sets as objects and the injective maps as morphisms. We also consider the complete variant of this category $\mathcal{J}nj$, as well as a connected variant $\mathcal{J}nj$, where we restrict ourselves to finite sets \underline{r} of cardinal $r \geq 2$.

For the non-unitary operad P underlying a unitary operad P_+ , we have restriction morphisms $f^* : P(\underline{s}) \rightarrow P(\underline{r})$ naturally associated to all injections $f : \underline{r} \rightarrow \underline{s}$ and extending the restriction morphisms of §3.2.1, as well as augmentations $\epsilon : M(\underline{r}) \rightarrow \mathbb{1}$. The collection P forms a diagram over the category $\mathcal{J}nj_{>0}$ therefore and comes also equipped with an augmentation towards the underlying collection of the commutative operad Com . To get the construction of the extended restriction morphisms from the plain ones, we just adapt the arguments of Proposition 3.5.6.

The associativity of restriction morphisms with respect to the partial composition products in Figure 3.4-3.5 holds same once we replace the arities $r - 1$, $s - 1$, $r + s - 1$, occurring in our diagrams, by appropriate finite set operations, and similarly in the case of the equivariance and unit relations.



Part 1

Braids and E_2 -operads

The Little Discs Model of E_n -operads

The first purpose of this chapter is to recall the definition of the operad of little n -discs D_n , and to explain the definition of the notion of E_n -operad. These recollections form the subject matter of the first section of the chapter (§4.1). In a second step, we give a survey of classical results on the homology of the little disc operads. This subject is addressed in our second section (§4.2).

The homology functor naturally goes from spaces to graded modules. In good cases, the homology of a space also inherits a coalgebra structure, dual to the standard commutative algebra structure of the cohomology, and the homology defines a symmetric monoidal functor from the category of spaces towards counitary cocommutative coalgebras in graded modules. This assertion implies that the homology of an operad forms an operad in the category of counitary cocommutative coalgebras in graded modules (we say graded Hopf operad for short), and the ultimate aim of §4.2 is to determine the structure associated to the little discs operads.

To complete our account, we provide an introduction to geometrical variants of the little discs operads: the operad of framed little discs, obtained by adding a rotation parameter in the definition of the ordinary little discs operad; and the Fulton-MacPherson operad, which is a model of E_n -operad obtained by a compactification of the configuration spaces of points in the plane. We address these subjects in an outlook section (§4.3). We also briefly explain the relationship between the little 2-discs operad and an operad defined by another compactification of configuration spaces, the Deligne-Mumford compactification, whose terms represents the moduli spaces of stable marked curves of genus zero. We finally devote an appendix section (§4.4) to the definition of the symmetric monoidal structure on the category of graded modules.

In this book, we deal with non-unitary operad structures as soon as we perform in-depth constructions on operads, and for technical reasons, we systematically regard unitary operads as unitary extensions of an underlying non-unitary operad. Therefore, in contrast with standard conventions, we assume that the little n -discs operad satisfies $D_n(0) = \emptyset$ in the basic case. The unitary version of the operad little n -discs, more usually considered in the literature, is denoted by D_{n+} , and is obtained by adding an arity zero term $D_{n+}(0) = pt$ to this non-unitary operad D_n .

Most results and concepts surveyed in this chapter come from [25, 26, 134] with regard to the definition of the little discs operads and the applications to iterated loop spaces, and [7, 40, 41] with regard to the homology of little discs and configuration spaces.

We consider operads in topological spaces from now on. We have to recall some concepts of homotopical algebra which become necessary when we have to compare operads defined in this category. We do not need more than some basic definitions

for the moment. We give a more comprehensive introduction to homotopical algebra constructions in §II.1, when we really start using the methods of this theory.

To begin with, recall that a map of topological spaces $f : X \rightarrow Y$ is a weak-equivalence if this map induces a bijection at the level of connected component sets $f_* : \pi_0 X \xrightarrow{\cong} \pi_0 Y$, and an iso at the level of homotopy groups $f_* : \pi_n(X, x_0) \xrightarrow{\cong} \pi_n(X, f(x_0))$, for all dimension n , and every choice of base points $x_0 \in X$. We say that a morphism of operads in topological spaces $\phi : P \rightarrow Q$ is a weak-equivalence if each component of this morphism $\phi(r) : P(r) \rightarrow Q(r)$ defines a weak-equivalence of topological spaces. We also deal with augmented non-unitary Λ -operads and augmented non-unitary Λ -sequences (see §3.2) in our study. We similarly define the weak-equivalences of these categories as the class of morphisms which are weak-equivalences of spaces arity-wise.

We generally use the notation $\xrightarrow{\sim}$ to mark a class of distinguished weak-equivalences in a category, like the weak-equivalences of topological spaces, and the weak-equivalences of operads. Recall that a homotopy equivalence of topological spaces is automatically a weak-equivalence. The converse implication holds for cell complexes, but not in general. In the operad case, we will consider homotopy equivalences in the operadic sense, which are invertible up to homotopy in the category of operads (we refer to the foreword for an introduction to this topic). Let us observe that a morphism of operads in topological spaces $\phi : P \rightarrow Q$ whose components $\phi(r) : P(r) \rightarrow Q(r)$ are homotopy equivalences of spaces for all $r \in \mathbb{N}$ is a weak-equivalence of operads, but not necessarily a homotopy equivalence of operads, because the homotopy inverses of the maps $\phi(r) : P(r) \rightarrow Q(r)$ do not necessarily form an operad morphism.

We consider the homotopy category of the category of operads in topological spaces $\text{Ho}(\mathcal{J}op\mathcal{O}p)$ defined by formally inverting the weak-equivalences in the category of operads. We do not need more than this rough idea for the moment (we will give more details on the definition of a homotopy category in the setting of model categories in §II.1).

4.1. The definition of the little discs operads

The purpose of this section, as we just explained, is to recall the definition of the little n -discs operad, and of the derived notion of an E_n -operad. To complete our account, we provide a short survey of the applications of operads to iterated loop spaces, because these original motivating applications yield some intuition on E_n -operads and on the associated algebra structures.

To begin with, we explain what the little discs are. We assume that n is a positive (finite) integer $n = 1, 2, \dots$ for the moment.

4.1.1. *The little discs.* Let \mathbb{D}^n denote the standard unit n -disc, defined as the subspace $\mathbb{D}^n = \{(t_1, \dots, t_n) \in \mathbb{R}^n \mid t_1^2 + \dots + t_n^2 \leq 1\}$ in the euclidean space \mathbb{R}^n . The little n -discs, giving the name of the little n -discs operad, are affine embeddings $c : \mathbb{D}^n \rightarrow \mathbb{D}^n$ of the form

$$c(t_1, \dots, t_n) = (a_1, \dots, a_n) + r \cdot (t_1, \dots, t_n),$$

for some translation vector $(a_1, \dots, a_n) \in \mathbb{D}^n$ and multiplicative scalar $r > 0$ such that $r^2 < 1 - (a_1^2 + \dots + a_n^2)$. To specify such an embedding, it is enough to give the subset $c(\mathbb{D}^n)$ since the definition of c amounts to assuming that $c(\mathbb{D}^n)$ forms an n -disc inside \mathbb{D}^n , with $(a_1, \dots, a_n) = c(0, \dots, 0) \in \mathbb{D}^n$ as center and

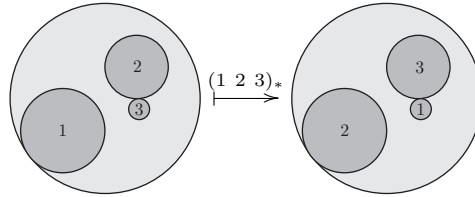

FIGURE 4.1. The representation of an element in the little 2-disc operad, and the action of the cyclic permutation $(1\ 2\ 3)$ on this element.

$r > 0$ as radius. This observation implies that little 2-discs are determined by their graphical representations, which we can therefore safely use in order to illustrate our constructions. By abuse of notation, we set $c = c(\mathbb{D}^n)$ and we use the same letter c to denote both our mapping from \mathbb{D}^n to \mathbb{D}^n and the corresponding subspace in \mathbb{D}^n .

The boundary of the unit n -disc \mathbb{D}^n , defined as the space of points $(t_1, \dots, t_n) \in \mathbb{D}^n$ such that $t_1^2 + \dots + t_n^2 = 1$, will be denoted by $\partial \mathbb{D}^n$. The interior of \mathbb{D}^n , defined as the complement of the subspace $\partial \mathbb{D}^n$ in \mathbb{D}^n , or equivalently, as the space of points $(t_1, \dots, t_n) \in \mathbb{D}^n$ such that $t_1^2 + \dots + t_n^2 < 1$, will be denoted by $\mathring{\mathbb{D}}^n$. We define the boundary of a little n -disc c as the subspace $\partial c = c(\partial \mathbb{D}^n)$ of $c = c(\mathbb{D}^n)$, and the interior as $\mathring{c} = c(\mathring{\mathbb{D}}^n)$.

4.1.2. *The little disc spaces.* The little n -discs space $D_n(r)$ formally consists of r -tuples $\underline{c} = (c_1, \dots, c_r)$ of affine embeddings $c_i : \mathbb{D}^n \rightarrow \mathbb{D}^n$, $i = 1, \dots, r$, of the form considered in §4.1.1, and such that $\mathring{c}_i \cap \mathring{c}_j = \emptyset$ for all pairs $i \neq j$.

The space $D_n(r)$ is equipped with the compact-open topology since the collection of affine maps $\underline{c} = (c_1, \dots, c_r)$ is naturally identified with an element of the mapping space $\text{Map}_{\mathcal{J}op}(\coprod^r \mathbb{D}^n, \mathbb{D}^n)$. Equivalently, we can use parameters associated with these maps, like the centers $(a_1, \dots, a_n) = c_i(0, \dots, 0) \in \mathbb{D}^n$ and the radius $r > 0$, to determine the topology of $D_n(r)$. The first approach is more convenient when we deal with applications of little discs to iterated loop spaces. The second equivalent definition is more convenient when we examine the connections of little discs with configuration spaces (see §4.2.1).

Figure 4.1 gives the representation of an element $\underline{c} \in D_n(3)$. In this picture, we use that the definition of \underline{c} as an r -tuple $\underline{c} = (c_1, \dots, c_r)$ amounts to assuming that the little n -discs $c_1, \dots, c_r \subset \mathbb{D}^n$ are indexed by the elements $i = 1, \dots, r$. We have a natural mapping $s_* : D_n(r) \rightarrow D_n(r)$, associated to each permutation $s \in \Sigma_r$, formally defined by $s_*(c_1, \dots, c_r) = (c_{s^{-1}(1)}, \dots, c_{s^{-1}(r)})$, for any $\underline{c} = (c_1, \dots, c_r) \in D_n(r)$. Pictorially, the mapping $s_* : D_n(r) \rightarrow D_n(r)$ is given by an obvious reindexing operation: we apply the permutation $s \in \Sigma_r$ to the index $i = 1, \dots, r$ associated with each little n -disc of $\underline{c} = (c_1, \dots, c_r) \in D_n(r)$ in order to get the picture of $s_*(\underline{c}) \in D_n(r)$ from the picture of \underline{c} (see Figure 4.1 for an example).

The collection $D_n = \{D_n(r)\}$, where the space $D_n(r)$ is equipped with this action of Σ_r , for each $r \in \mathbb{N}$, forms a symmetric sequence.

/r

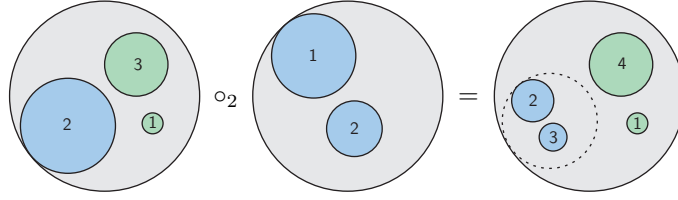

FIGURE 4.2. The composition of elements in the little 2-disc operad.

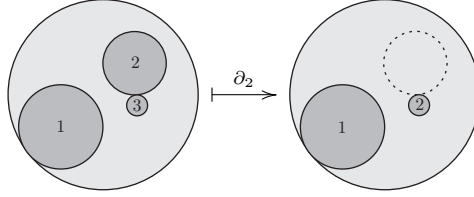

FIGURE 4.3. The representation of a restriction operation in the little 2-disc operad.

In certain applications, we may prefer to consider the symmetric collection associated to D_n , of which terms are indexed by arbitrary finite sets \mathbf{r} , rather than this symmetric sequence. The elements of a term $D_n(\mathbf{r})$ in this symmetric collection are identified with collections of little discs $\underline{c} = \{c_{i_1}, \dots, c_{i_r}\}$ indexed by the elements of the given set $\mathbf{r} = \{i_1, \dots, i_r\}$ rather than by ordinal elements $i = 1, \dots, r$. The action of finite set bijections $u \in \mathcal{B}ij(\mathbf{r}, \mathbf{s})$ on the symmetric collection $D_n(\mathbf{r})$ is the obvious extension of the reindexing process associated with permutations.

4.1.3. *The operad of little n -discs.* We consider the symmetric sequence of little n -disc spaces defined in the previous paragraph. We have a natural unit element $1 \in D_n(1)$ given by the 1-tuple $1 = (id)$, where we consider the identity mapping $id : \mathbb{D}^n \rightarrow \mathbb{D}^n$, with the full unit disc $\mathbb{D}^n = id(\mathbb{D}^n)$ as corresponding subspace $id(\mathbb{D}^n) \subset \mathbb{D}^n$.

We now define the partial composition operations $\circ_i : D_n(r) \times D_n(s) \rightarrow D_n(r + s - 1)$ giving the operadic composition structure of D_n . To $\underline{a} = (a_1, \dots, a_r) \in D_n(r)$ and $\underline{b} = (b_1, \dots, b_s) \in D_n(s)$, we associate the $r + s - 1$ -tuple of little discs

$$\underline{a} \circ_i \underline{b} = (a_1, \dots, a_{i-1}, a_i \circ b_1, \dots, a_i \circ b_s, a_{i+1}, \dots, a_r) \in D_n(r + s - 1),$$

where the expression $a_i \circ b_k$ refers to the composite of the maps $a_i : \mathbb{D}^n \rightarrow \mathbb{D}^n$ and $b_k : \mathbb{D}^n \rightarrow \mathbb{D}^n$. Note that such a composite $a_i \circ b_k$ is still an embedding of the form specified in §4.1.1. Intuitively, the little n -disc configuration $\underline{a} \circ_i \underline{b} \in D_n(r + s - 1)$ is obtained by putting the configuration $\underline{b} = (b_1, \dots, b_s)$ in the little disc of $\underline{a} = (a_1, \dots, a_r)$ indexed by i , as depicted in Figure 4.2. In this process, we apply the affine mapping $a_i : \mathbb{D}^n \rightarrow \mathbb{D}^n$, equivalent to the given little n -disc $a_i = a_i(\mathbb{D}^n)$, in order to put the little n -disc configuration \underline{b} at the appropriate position and scale.

The definition of the operad D_n , for $n = 1, 2, \dots$, is now complete since we can immediately check, by a straightforward inspection of definitions, that the unit and associativity axioms of operads are satisfied by our composition operations.

4.1.4. *The unitary version of the little n -disc operad.* We take the convention that $D_n(0) = \emptyset$ (as explained in the introduction of this chapter). On the other hand, we can formally extend the definitions of the previous paragraphs to include an empty collection of little n -discs as an arity 0 element of a unitary version of the little n -discs operad. We then obtain an operad D_{n+} such that $D_{n+}(0) = *$, where $*$ refers to both the one-point set, and the element of this set, which represents the distinguished arity 0 element of the unitary operad D_{n+} .

This operad D_{n+} forms a unitary extension of the non-unitary little n -discs operad D_n (in the sense considered in §1.1.20), and the partial composites with the arity 0 element $*$ in $D_{n+}(0)$ are equivalent to restriction operations $\partial_k : D_{n+}(r) \rightarrow D_{n+}(r-1)$ so that $\partial_k(\underline{c}) = \underline{c} \circ_k *$ (see §3.2.1). The image of a little n -disc collection $\underline{c} = (c_1, \dots, c_r)$ under the restriction map $\partial_k : D_{n+}(r) \rightarrow D_{n+}(r-1)$ can readily be identified with the $r-1$ -tuple $\partial_k(\underline{c}) = (c_1, \dots, \widehat{c}_k, \dots, c_r)$, where the k th term of \underline{c} has been removed (see Figure 4.3 for an example). Recall that the permutations and the restriction operations generate a contravariant action of the category of ordinal injections Λ (see §3.2.2) on the underlying sequence of the operad D_n , which accordingly forms an augmented non-unitary Λ -sequence (see §3.2). The action of a map $u : \{1 < \dots < r\} \rightarrow \{1 < \dots < s\}$ defining a morphism of that category Λ on a little discs collection $\underline{c} = (c_1, \dots, c_s) \in D_n(s)$ is simply given by $u^*(\underline{c}) = (c_{u(1)}, \dots, c_{u(r)})$, and in this picture, the restriction operation $\partial_k : D_n(r) \rightarrow D_n(r-1)$ corresponds to the map $\partial^k : \{1 < \dots < r-1\} \rightarrow \{1 < \dots < r\}$ jumping over the value $k \in \{1 < \dots < r\}$ in the image set (see §3.2.1).

In the general study of unitary operads in §3.2, we also deal with augmentation morphisms which reflect the operadic composites $\epsilon(p) = p(*, \dots, *)$ where we plug the unitary element $*$ in all inputs of the operation $p = p(x_1, \dots, x_r)$. In the case of the little n -discs operads in topological spaces, these augmentations reduce to the obvious canonical maps $\epsilon : D_n(r) \rightarrow pt$.

The unitary operads D_{n+} naturally occur in applications to iterated loop spaces. The computation of the homology of the little discs operads (see the next section) involves the restriction morphisms arising from the unitary structures too.

4.1.5. *The operads of little discs as a nested sequence of operads.* The operad of little n -discs, as defined in the previous paragraphs for a finite integer $n = 1, 2, \dots$, actually form a nested sequence of topological operads

$$D_1 \hookrightarrow D_2 \hookrightarrow \dots \hookrightarrow D_n \hookrightarrow \dots$$

We take the colimit $D_\infty = \text{colim}_n D_n$ to add a terminal term to this sequence and to define the infinite dimensional version of the little disc operads. We have an extension of this construction in the unitary setting too.

We use the equatorial embedding of the n -disc \mathbb{D}^n into the $n+1$ -disc \mathbb{D}^{n+1} , formally defined by $\iota(t_1, \dots, t_n) = (t_1, \dots, t_n, 0)$, to regard \mathbb{D}^n as a subspace of \mathbb{D}^{n+1} . To a little n -disc $c : \mathbb{D}^n \rightarrow \mathbb{D}^n$, we associate the little $n+1$ -disc $\iota(c) : \mathbb{D}^{n+1} \rightarrow \mathbb{D}^{n+1}$ with the same center as c in the equatorial disc $\mathbb{D}^n \subset \mathbb{D}^{n+1}$, and the same radius $r > 0$. Thus, if we assume $c(t_1, \dots, t_n) = (a_1, \dots, a_n) + r \cdot (t_1, \dots, t_n)$, then this little $n+1$ -disc $\iota(c)$ is formally defined by $\iota(c)(t_1, \dots, t_n, t_{n+1}) = (a_1, \dots, a_n, 0) + r \cdot (t_1, \dots, t_n, t_{n+1})$.

The operad embedding $\iota : D_n \hookrightarrow D_{n+1}$ is defined by the formula $\iota(\underline{c}) = (\iota(c_1), \dots, \iota(c_r))$ for any $\underline{c} = (c_1, \dots, c_r) \in D_n(r)$ and each $r \in \mathbb{N}$ (see Figure 4.4 for the graphical representation of this process). We readily see that the collec-

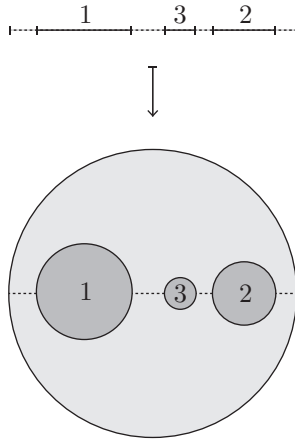

FIGURE 4.4. The image of a little 1-disc configuration in the little 2-disc operad.

tion of these mappings preserve the internal structure of operads, and hence, do define operad morphisms, which moreover admit an obvious extension to the unitary version of the little discs operads. We can check further that our mappings $\iota : D_n(r) \hookrightarrow D_{n+1}(r)$, are topological inclusions, for all $r \in \mathbb{N}$, and hence, the little n -disc space $D_n(r)$ can really be identified with a subspace of $D_{n+1}(r)$.

To complete our definitions, we record the following result (already mentioned in the chapter introduction) about the initial term of the sequence D_1 and the added terminal term D_∞ :

PROPOSITION 4.1.6.

- (a) We have $\pi_0 D_1(r) = \Sigma_r$, for $r = 1, 2, \dots$, and the canonical maps $D_1(r) \rightarrow \pi_0 D_1(r)$ define a weak-equivalence of topological operads $D_1 \xrightarrow{\sim} \mathbf{As}$ between the little 1-disc operad D_1 and the associative operad \mathbf{As} , formed in the category of sets and viewed as a discrete topological operad. In the unitary setting, we have similarly $\pi_0 D_{1+} \simeq \mathbf{As}_+$.
- (b) We have $\pi_0 D_\infty(r) = *$, for $r = 1, 2, \dots$, and the canonical maps $D_\infty(r) \rightarrow \pi_0 D_\infty(r)$ define a weak-equivalence of topological operads $D_\infty \xrightarrow{\sim} \mathbf{Com}$ between D_∞ and the commutative operad \mathbf{Com} , formed in the category of sets and viewed as a discrete topological operad. In the unitary setting, we have similarly $\pi_0 D_{\infty+} \simeq \mathbf{Com}_+$.

PROOFS AND EXPLANATIONS. In the proposition, we consider the sets of path-connected components $\pi_0 P(r)$ associated to the topological spaces $P(r)$ underlying an operad P . The collection of sets $\pi_0 P(r)$ inherits an operad structure from P . Moreover, the collection of maps $P(r) \rightarrow \pi_0 P(r)$ defines a morphism of topological operads, where we regard the sets $\pi_0 P(r)$ as discrete topological spaces, as stated in the proposition. This assertions formally follows from the obvious observation that the mapping $\pi_0 : X \mapsto \pi_0 X$, from topological spaces to sets, defines a symmetric monoidal functor with the functors from sets to discrete spaces as adjoint

(see §§2.1.3-2.1.7). The claim that $P \rightarrow \pi_0 P$ defines a weak-equivalence of topological operads, as formulated in the proposition, amounts to the assertion that the path-connected components of the spaces $P(r)$ are weakly-contractible.

In the case $P = D_1$, the embedding of a collection of little intervals (of little 1-discs) $\underline{c} = (c_1, \dots, c_r) \in D_1(r)$ in the one dimensional space \mathbb{D}^1 determines an order relation between the intervals. To be explicit, we set $c_i < c_j$ when we have $c_i(0) < c_j(0)$, or equivalently, when $c_i(s) \leq c_j(t)$ for all $s, t \in \mathbb{D}^1$. The obtained ordering $c_{i_1} < \dots < c_{i_r}$ determines a permutation (i_1, \dots, i_r) of the indices $(1, \dots, r)$ which we associate to ~~our~~ the little 1-disc configuration (c_1, \dots, c_r) . For the little configuration of Figure 4.4, for instance, we obtain the permutation $(1, 3, 2)$.

This assignment gives a map $D_1(r) \rightarrow \Sigma_r$, for any $r \in \mathbb{N}$, and we can easily check, by providing a map in the converse direction and a contracting homotopy, that this map is a homotopy equivalence of topological spaces. From this verification, we conclude that $\pi_0 D_1(r) = \Sigma_r$ and the path-connected components of $D_1(r)$ are contractible, as asserted. Recall that the permutation groups $\Sigma_r, r > 0$, define the underlying collection of the associative operad in sets As . By inspection of definitions, we can also easily check that the relation $\pi_0 D_1 = As$ holds as an identity of operads. In the unitary context, we simply consider an additional base point in arity 0 on both sides of the identity $\pi_0 D_1 = As$, and we easily check, again, that the obtained an identity $\pi_0 D_{1+} = As_+$ holds in the category of unitary operads.

We refer to [26, Lemma 2.50] for a proof that each space $D_\infty(r)$ is contractible, so that we have $\pi_0 D_\infty(r) = *$, for each $r > 0$, where we use the notation $*$ for the one-point set (viewed as a terminal object of the category of sets). Recall that the commutative operad in sets Com is also given by $Com(r) = pt = *$, for all $r > 0$. In the case of one-point sets, the existence of the relation $\pi_0 D_\infty(r) = *$ for each $r > 0$ automatically implies that the identity $\pi_0 D_\infty = Com$ holds the category of operads, and we similarly have an identity $\pi_0 D_{\infty+} = Com_+$ in the category of operads in the unitary setting. \square

The operads D_n , where $1 < n < \infty$, are not weakly-equivalent to discrete operads (unlike D_1 and D_∞). This observation can be deduced from the homology computations of the next section. We readily see, nonetheless, that the spaces $D_n(r)$ are path-connected for $n > 1$. Accordingly, the identity of the theorem $\pi_0 D_n = Com$ in assertion (b) holds as soon as $n > 1$, and we similarly have $\pi_0 D_{n+} = Com_+$ in the unitary setting.

4.1.7. *Relationship with the little n -cubes operad.* The little n -cubes operad, denoted by C_n , is a variant of the little n -discs operad D_n of which elements consist of collections of cube (rather than disc) embeddings. To be precise, we define a little cube c as a map $c_i : [0, 1]^n \hookrightarrow [0, 1]^n$, of the form

$$c_i(t_1, \dots, t_n) = (a_1 + (b_1 - a_1)t_1, \dots, a_n + (b_n - a_n)t_n), \tag{4.1.7}$$

for each point $(t_1, \dots, t_n) \in [0, 1]^n$, where $(a_1, \dots, a_n), (b_1, \dots, b_n) \in [0, 1]^n$ are given parameters such that $0 \leq a_k < b_k \leq 1$, for each k . The space $C_n([0, 1]^n)$ accordingly defines an n -dimensional cube in $[0, 1]^n$ with non-empty interior $\overset{\circ}{c}_i$ and faces parallel to the faces of the ambient unit cube. The n -tuples $(a_1, \dots, a_n), (b_1, \dots, b_n) \in [0, 1]^n$ represent the extremal vertices of this little cube.

The spaces $C_n(r)$, forming the little n -cubes operad C_n , consist of r -tuples of little n -cubes $\underline{c} = (c_1, \dots, c_r)$ with disjoint interiors. Thus, a typical element of the

little n -cubes operad is represented by a picture of the following form:

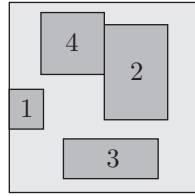

The definition of the operad structure on little n -cubes is an obvious variation of the definition of the operad structure on little n -discs.

The operad of little n -discs is weakly-equivalent to the operad of little n -cubes as an operad in topological spaces (we refer to [20] arguments giving a conceptual proof of this statement). The operads of little cubes can be used to define models of suspension maps in iterated loop space theory (see [134, ??]), while the operads of little discs can not. But the little discs operads make some of our constructions more natural, and we therefore prefer to use this model. The operads of little discs also have a framed version, which is also needed for certain geometric constructions extending the applications of operads to iterated loop spaces (reviewed in the next paragraphs), but where spheres without a distinguished base point naturally occur (we provide an introduction to this subject in §4.3)

4.1.8. *Iterated loop spaces.* The little n -discs are used to represent composition schemes of continuous maps $\alpha : \mathbb{D}^n \rightarrow X$ towards a space X equipped with a fixed base point x_0 so that $\alpha|_{\partial \mathbb{D}^n} = x_0$. The space formed by these maps

$$\Omega^n X = \{\alpha \in \mathbf{Map}_{\mathcal{J}op}(\mathbb{D}^n, X) \mid \alpha|_{\partial \mathbb{D}^n} = x_0\},$$

together with the topology inherited from $\mathbf{Map}_{\mathcal{J}op}(\mathbb{D}^n, X)$, is one of the possible equivalent definitions for the n -fold loop space associated to X . In the case $n = 1$, we retrieve with this construction the basic definition of the space of loops $\alpha : \mathbb{D}^1 \rightarrow X$ based at x_0 . This 1-fold loop space is more usually denoted by ΩX (with the dimension exponent dropped from the notation).

The pairs (X, x_0) , consisting of a topological space X together with a distinguished base point $x_0 \in X$, form the objects of the category of pointed spaces $\mathcal{J}op_*$. The morphisms of this category are the morphisms of topological spaces preserving the base point. In general, we use the expression of the underlying space X for the objects of $\mathcal{J}op_*$, and the notation $*$ to refer to the base point attached to any such space (except in particular cases where the base point has to be specified). Implicitly, we abusively consider that a space X , regarded as an object of $\mathcal{J}op_*$, comes together with a base point, which is part of its internal structure.

The loop space $\Omega^n X$ is equipped with a natural base point, defined by the constant map towards the base point of X . The assignment $\Omega^n : X \mapsto \Omega^n X$ accordingly gives a functor $\Omega^n : \mathcal{J}op_* \rightarrow \mathcal{J}op_*$ on the category of pointed spaces $\mathcal{J}op_*$. The n -fold loop space functor $\Omega^n : \mathcal{J}op_* \rightarrow \mathcal{J}op_*$ can formally be identified with the n -fold composite of the basic single loop space functor $\Omega : \mathcal{J}op_* \rightarrow \mathcal{J}op_*$. This observation motivates the terminology of iterated loop space for spaces of the form $Y = \Omega^n X$.

4.1.9. *Operations on iterated loop spaces associated to little discs.* Each element $\underline{c} \in D_{n+}(r)$ in the unitary operad of little n -discs D_{n+} determines an r -fold operation $\underline{c} : \Omega^n X \times \cdots \times \Omega^n X \rightarrow \Omega^n X$. Let us recall this construction.

Let $\underline{c} = (c_1, \dots, c_r) \in D_{n+}(r)$. The assumption that each little disc c_i has a radius > 0 in the definition of the little n -discs operad implies that the map $c_i : \mathbb{D}^n \rightarrow \mathbb{D}^n$ induces an affine isomorphism between \mathbb{D}^n and $c_i = c_i(\mathbb{D}^n)$. To a collection of n -fold loop space elements $\alpha_1, \dots, \alpha_r \in \Omega^n X$, we associate the map $\alpha : \mathbb{D}^n \rightarrow X$ such that

$$\alpha(t_1, \dots, t_n) = \begin{cases} \alpha_i(c_i^{-1}(t_1, \dots, t_n)), & \text{when } (t_1, \dots, t_n) \text{ belongs to the image} \\ & \text{of a small disc } c_i = c_i(\mathbb{D}^n), \\ * & \text{(the base point of } X), \text{ otherwise.} \end{cases}$$

The assumption $\alpha_i|_{\partial \mathbb{D}^n} = *$ for the elements of $\Omega^n X$ ensures that this map is well defined and continuous over \mathbb{D}^n . Moreover, we clearly have $\alpha|_{\partial \mathbb{D}^n} = *$. Thus, the map $\alpha : \mathbb{D}^n \rightarrow X$ defines an element of the n -fold loop space $\alpha = \underline{c}(\alpha_1, \dots, \alpha_r) \in \Omega^n X$ naturally associated to $\alpha_1, \dots, \alpha_r \in \Omega^n X$, and this mapping $\underline{c} : (\alpha_1, \dots, \alpha_r) \mapsto \underline{c}(\alpha_1, \dots, \alpha_r)$ gives the operation $\underline{c} : \Omega^n X \times \cdots \times \Omega^n X \rightarrow \Omega^n X$ associated to our operad element $\underline{c} \in D_{n+}(r)$.

Intuitively, the composite $\alpha = \underline{c}(\alpha_1, \dots, \alpha_r) : \mathbb{D}^n \rightarrow \Omega^n X$ is obtained by applying the maps α_i to the little n -discs of the configuration \underline{c} , and the composition with c_i^{-1} simply amounts to performing a suitable change of scale before applying this map α_i . The complement of the little n -discs inside \mathbb{D}^n is sent to the base point.

We easily see that the definition of the operad structure on our little n -discs spaces reflects the structures associated with the corresponding operations on n -fold loop spaces, and we obtain the following statement:

PROPOSITION 4.1.10. *The construction of §4.1.9 provides each n -fold loop space $\Omega^n X$ with an action of the (unitary version of the) little n -discs operad D_{n+} so that $\Omega^n X$ forms an algebra over this operad.*

To summarize the idea, this proposition gives the construction of an algebraic structure (an algebra over D_{n+}) from a topological object (an n -fold loop space). The question is how far the algebraic structure provides a faithful picture of the topological objects. The answer is provided by the following recognition theorem, which gave the first motivation for the introduction of operads in topology:

THEOREM 4.1.11 (J. Boardman, R. Vogt [25, 26], P. May [134]). *For any space Y equipped with an action of the (unitary) operad of little n -discs D_{n+} , we have a pointed space $B_n Y$, naturally associated to Y , together with maps $\Omega^n B_n Y \leftarrow \cdot \xrightarrow{\sim} Y$ commuting with D_{n+} -actions, where the middle term is again equipped with a D_{n+} -action and the right hand side map is a weak-equivalence.*

The left hand side map is a weak-equivalence too when Y is path-connected (or, more generally, when $\pi_0 Y$ forms a group). \square

The cited references provide different approaches of this theorem. The arguments of [134] rely on an approximation theorem (see Theorem 2.7 in *loc. cit.*) asserting that free algebras over D_{n+} are weakly-equivalent to iterated loop spaces of suspensions $\Omega^n \Sigma^n X$ (see again *loc. cit.*) and returns the n -fold delooping $B_n Y$ in one step. The arguments of [25, 26] rely on an inductive delooping process.

The space $\Omega^n B_n Y$ is not weakly-equivalent to Y in general, but forms a so-called group completion of Y (see [2] for an introduction to this notion and further references on this subject).

We will not go much further into the applications of operads to iterated loop spaces. We refer to the literature, notably the already mentioned monographs [26, 134], for a comprehensive account of that subject. We simply want to explain, in order to complete our survey, that the action of the little n -discs operad on n -fold loop spaces represents a fine homotopical structure underlying the classical definition of the homotopy groups of pointed spaces, and we address this subject matter in the next paragraphs.

4.1.12. *Basic motivations: the definition of homotopy groups.* The n th homotopy group $\pi_n(X, x_0)$ of a space X equipped with a base point $x_0 \in X$ can be defined as the set of homotopy classes of maps $u : \mathbb{D}^n \rightarrow X$ which are identical to the base point $x_0 \in X$ on $\partial \mathbb{D}^n \subset \mathbb{D}^n$. Simply recall that a homotopy between any such maps $u_0, u_1 : \mathbb{D}^n \rightarrow X$ consists of a map $h : [0, 1] \times \mathbb{D}^n \rightarrow \mathbb{D}^n$ such that $h(0, \cdot) = u_0$, $h(1, \cdot) = u_1$ and $h(s, \cdot) \mid_{\partial \mathbb{D}^n} = x_0$, for all $s \in [0, 1]$.

The group $\pi_1(X, x_0)$ is identified with the fundamental group of X because a based loop on the pointed space X is nothing but a map $\alpha : \mathbb{D}^1 \rightarrow X$ such that $\alpha \mid_{\partial \mathbb{D}^1} = x_0$, and we have a similar identification for homotopies. Recall that the fundamental group $\pi_1(X, x_0)$ is not abelian in general while all higher homotopy groups $\pi_n(X, x_0)$, $n > 1$, are. We aim to revisit the definition of the group structure on $\pi_n(X, x_0)$, from the operadic viewpoint.

We have a formal identity between the group $\pi_n(X, x_0)$ and the set of path-connected components of the n -fold loop space $\Omega^n X$. The group multiplication of $\pi_n(X, x_0)$, as usually defined (see for instance [177, §IV]), can be identified with an operation $\mu : \Omega^n X \times \Omega^n X \rightarrow \Omega^n X$, formed at the loop space level, and associated with an arity 2 element the little n -cubes operad $C_n(2)$. (We then have to define the n -fold loop space $\Omega^n X$ as a set of maps on a cube $[0, 1]^n$ instead of a disc \mathbb{D}^n , but this does not change the result of the construction.) In our setting, we consider an operation $\mu = \underline{c} : \Omega^n X \times \Omega^n X \rightarrow \Omega^n X$ associated an arity 2 element in the little n -discs operad $\underline{c} \in D_n(2)$.

If we assume $n > 1$, then all operations $\underline{c} : \Omega^n X \times \Omega^n X \rightarrow \Omega^n X$ associated to such a little n -disc configuration $\underline{c} \in D_n(2)$ are the same up to homotopy: indeed, since $D_n(2)$ is path-connected, any pair of little n -disc configurations $\underline{c}^0, \underline{c}^1 \in D_n(2)$ are connected by a path \underline{c}^s , $s \in [0, 1]$, in $D_n(2)$, and the collection of operations $\underline{c}^s : \Omega^n X \times \Omega^n X \rightarrow \Omega^n X$, $s \in [0, 1]$, associated to this path determines a homotopy between the operations associated to \underline{c}^0 and \underline{c}^1 on $\Omega^n X$.

This argument line also implies that the multiplication defined by an element $\underline{c} \in D_n(2)$ is homotopy equivalent to the multiplication determined by the transposed operation $(1\ 2) \cdot \underline{c} \in D_n(2)$. Hence, we obtain that a multiplication on $\pi_n(X, x_0)$ is equal to the opposite operation, and as a consequence, that the group $\pi_n(X, x_0)$ is commutative.

In the case of $n = 1$, we have two choices of multiplications in homotopy, corresponding to the two path-connected components of the space $D_1(2)$, and these multiplications are transposed to each other. Thus we retrieve the non-commutativity of the fundamental group $\pi_1(X, x_0)$ from the identity $\pi_0 D_1(2) = \mathcal{A}\mathcal{S}(2)$.

The homotopy, giving the associativity of the multiplication on homotopy groups, can also be defined by a one parameter family of triple operations $\mu_3^s(\cdot, \cdot, \cdot) :$

$\Omega^n X \times \Omega^n X \times \Omega^n X \rightarrow \Omega^n X$, $s \in [0, 1]$, associated with a path in the little n -discs space $D_n(3)$. The inversion operation is apart because the homotopies giving this operation are not included in the structure associated with the little n -discs operad.

By pushing our operadic analysis further, we can regard the associativity (respectively, commutativity) of the group structure on $\pi_n(X, x_0)$ as a consequence of the operad identity $\pi_0 D_{1+} = \mathbf{As}_+$ (respectively, $\pi_0 D_{n+} = \mathbf{Com}_+$ for $n > 1$). We mention after Proposition 4.1.6 that the operads D_{n+} are not componentwise contractible for $1 < n < \infty$. We precisely check in the next section that $D_n(2)$ is homotopy equivalent to a sphere \mathbb{S}^{n-1} and that each space $D_n(r)$ has a non-trivial homology. Fine structures arising from the operad little n -discs operad can be revealed by studying homology groups $H_*(\Omega^n X, \mathbb{k})$ rather than restricting our consideration to the set of connected components $\pi_n(X, x_0) = \pi_0(\Omega^n X)$. The monograph [40] gives a complete description of these homological structures in the case where the coefficient ring of the homology is a field.

4.1.13. *The notion of an E_n -operad.* To conclude this chapter, we just record the formal definition of the notion of an E_n -operad: a non-unitary (respectively, unitary) E_n -operad in topological spaces is an operad P , in the category of topological spaces, which is isomorphic to the operad of little n -discs D_n (respectively, D_{n+}) in the homotopy category of topological operads $\mathbf{Ho}(\mathcal{TopOp})$.

By definition of the homotopy category $\mathbf{Ho}(\mathcal{TopOp})$, this definition amounts to assuming that P is connected to D_n by a chain of morphisms of topological operads

$$P \xleftarrow{\sim} \cdot \xrightarrow{\sim} \cdots \xrightarrow{\sim} D_n$$

inducing isomorphisms on homotopy groups, and hence, defining weak-equivalences in the category of topological operads.

The existence of a model structure on \mathcal{TopOp} , which we study in §1, implies that such a chain can be reduced to a zig-zag of two weak-equivalences

$$P \xleftarrow{\sim} \cdot \xrightarrow{\sim} D_n.$$

The same observations hold in the unitary context.

In many applications, authors take the additional assumption that E_n -operads are cofibrant as symmetric collections (we explain the definition of this concept in §II.1.4 and §II.3.1) in order to ensure that the category of algebras associated with different models of E_n -operads are Quillen equivalent (see §II.1.4). The interesting reader can notice that all instances of E_n -operads considered in this work (including the reference model of little n -discs by the way) are cofibrant as symmetric collections. But we will not pay attention to this technical point. Furthermore, as soon as we consider homotopy automorphism groups, we need to deal with cofibrant models of E_n -operads, and this requirement is actually stronger than being cofibrant as a symmetric collection (see for instance [22]).

In the cofibrant case, the model category axioms implies that we can reduce our chain of a weak-equivalences, connecting P and D_n , to a single element $P \xrightarrow{\sim} D_n$, but we usually do not need to make this weak-equivalence explicit too.

In the case $n = 1, \infty$, the result of Proposition 4.1.6 immediately implies:

PROPOSITION 4.1.14.

- (a) *A non-unitary operad P is E_1 if and only if we have $\pi_0 P(r) = \Sigma_r$, for $r = 1, 2, \dots$, and the canonical maps $P(r) \rightarrow \pi_0 P(r)$ define a weak-equivalence of topological operads $P \xrightarrow{\sim} \mathbf{As}$, where we regard the associative operad \mathbf{As} ,*

formed in the category of sets, as a discrete topological operad. A similar result holds in the unitary context, with the non-unitary associative operad \mathbf{As} replaced by the unitary one \mathbf{As}_+ .

- (b) A non-unitary operad P is E_∞ if and only if we have $\pi_0 P(r) = *$, for $r = 1, 2, \dots$, and the canonical maps $P(r) \rightarrow \pi_0 P(r)$ define a weak-equivalence of topological operads $P \xrightarrow{\sim} \mathbf{Com}$, where we regard the commutative operad \mathbf{Com} , formed in the category of sets, as a discrete topological operad. A similar result holds in the unitary context, with the non-unitary commutative operad \mathbf{Com} replaced by the unitary one \mathbf{Com}_+ . \square

Since the operads D_n are not equivalent to discrete operads for $1 < n < \infty$, we do not have such a simple characterization of E_n -operads in general. On the other hand, the existence of weak-equivalences $P \xleftarrow{\sim} \cdot \xrightarrow{\sim} D_n$ implies that E_n -operads have the same homology as the operad of little n -discs (and similarly in the unitary context). This already gives a simple criterion for the recognition of E_n -operads. But the study of the homology of E_n -operads gives the subject of the next section.

4.2. The homology (and cohomology) of the little discs operads

The goal of this section is to give a description of the homology of the little n -discs operads D_n , and as a byproduct of any E_n -operad. We work throughout this section with a fixed ground ring \mathbb{k} , which we take as coefficient ring for the homology $\mathbb{H}_*(X) = \mathbb{H}_*(X, \mathbb{k})$ and the cohomology $\mathbb{H}^*(X) = \mathbb{H}^*(X, \mathbb{k})$ of topological spaces. We need to assume that the ground ring is a field in order to have general structure result on the homology of operads. We can adopt this assumption to simplify, because we do not need more than the case of a characteristic zero field in subsequent applications, but our description of the homology of the little n -discs operads remains valid over any ring.

We naturally deal with objects defined in the category of graded modules, denoted by $gMod$. We have a symmetric monoidal structure, recalled in the appendix section §4.4, on the category of graded modules, and the homology of a space forms a counitary cocommutative coalgebra in that symmetric monoidal category (at least when we take a field as coefficient ring). When we apply the homology to a topological operad, we get an operad in the category of counitary cocommutative coalgebras in graded modules. We also speak about graded Hopf operads for short. We precisely aim to determine the graded Hopf operads defined by the homology of the little discs operads.

We adopt the following conventions. We use the prefix graded rather than the full expression of graded module, to refer to objects defined within the category of graded modules $gMod$. For instance, we speak about graded counitary cocommutative coalgebras, graded operads, \dots Following the convention of §2.2, we also generally use the prefix Hopf to refer to objects defined in a category of counitary cocommutative coalgebras. Therefore, we use the expression of a graded Hopf operad to refer to the structure defined by an operad in counitary cocommutative coalgebras in graded modules.

In mathematical formulas, we similarly use the notation $gCom_+^c$, rather than $gModCom_+^c$, to refer to the category of graded counitary cocommutative coalgebras, the notation gOp , rather than $gModOp$, for the category of graded operads, and the notation $gHopfOp$ for the category of graded Hopf operads. In Proposition 2.2.4, we observed that Hopf operads can be identified with counitary

cocommutative coalgebras in operads. In the graded context, this identity reads $g \mathcal{H}opf \mathcal{O}p = g \mathcal{C}om_+^c \mathcal{O}p = g \mathcal{O}p \mathcal{C}om_+^c$.

The homology of the little n -discs operads is essentially trivial when $n = 1, \infty$, since the topological spaces underlying these operads have contractible connected components (and similarly in the unitary context). Therefore most of our efforts are devoted to the cases where $1 < n < \infty$

In a first stage, we forget about operadic composition structures. We give a description of the cohomology of each space $D_n(r)$ as a graded unitary commutative algebra. In this context, we can replace the little n -discs spaces $D_n(r)$ by homotopy equivalent configuration spaces $F(\mathring{\mathbb{D}}^n, r)$, which do not form an operad but are more suitable for the analysis of topological structures. To begin with, we recall the definition of these spaces:

4.2.1. *Configuration spaces.* The space of configuration of r points in a topological space $M \in \mathcal{T}op$ is generally defined by:

$$F(M, r) = \{(a_1, \dots, a_r) \in M^r \mid a_i \neq a_j \text{ for all pairs } i \neq j\},$$

for any $r \in \mathbb{N}$. In what follows, we mostly consider the configuration space associated to the open n -discs $M = \mathring{\mathbb{D}}^n$. The configuration space associated to the euclidean space $M = \mathbb{R}^n$ is more usually considered in the operadic litterature. But the standard homeomorphism between the euclidean space and the open n -disc induces a homeomorphism at the configuration space level. Therefore, we can deduce results involving one of these configuration spaces from results involving the other. We easily see that:

To an element of the little n -discs operad $\underline{c} \in D_n(r)$, we associate the configuration of points $(c_1(0), \dots, c_r(0)) \in F(\mathring{\mathbb{D}}^n, r)$ defined by the centers of the little n -discs c_i , $i = 1, \dots, r$, of our collection $\underline{c} = (c_1, \dots, c_r)$, and we get a map $\omega : D_n(r) \rightarrow F(\mathring{\mathbb{D}}^n, r)$, which we call the disc center mapping. We have the following result:

PROPOSITION 4.2.2. *The disc center mapping defines a homotopy equivalence of topological spaces $\omega : D_n(r) \xrightarrow{\sim} F(\mathring{\mathbb{D}}^n, r)$, for each $r \in \mathbb{N}$.*

PROOF. Exercise or see [134, §4]. □

We have no operadic composition products on configuration spaces. Nonetheless, we still have some structure result when we focus on unitary composition operations. We then consider our notion of augmented non-unitary Λ -sequence which formalize this part of the structure attached to operads (see §3.2). Recall that the little n -discs operad D_n , has such a structure, which we associate to the unitary extension of this operad (see §4.1.4). Then we have the following statement:

PROPOSITION 4.2.3. *The collection of configuration spaces $F(\mathring{\mathbb{D}}^n, r)$ forms an augmented non-unitary Λ -sequence so that the disc center mappings $\omega : D_n(r) \xrightarrow{\sim} F(\mathring{\mathbb{D}}^n, r)$ form a morphism of augmented non-unitary Λ -sequences.*

EXPLANATIONS. The action of an ordinal injection $u : \{1 < \dots < r\} \rightarrow \{1 < \dots < s\}$ on an element $\underline{a} = (a_1, \dots, a_s) \in F(\mathring{\mathbb{D}}^n, s)$ is defined by $u^*(\underline{a}) = (a_{u(1)}, \dots, a_{u(r)})$. This construction clearly gives an action of our category Λ on the collection of configuration spaces, and we have an obvious canonical augmentation $\epsilon : F(\mathring{\mathbb{D}}^n, r) \rightarrow pt$, for each $r \in \mathbb{N}$, so that the collection $\{F(\mathring{\mathbb{D}}^n, r)\}$ forms

an augmented non-unitary Λ -sequence as stated in the proposition. We immediately see, from the definition of the augmented Λ -sequence structure on the little n -discs spaces $D_n(r)$ in §4.1.4, that the collection of disc center mappings $\omega : D_n(r) \xrightarrow{\sim} F(\mathring{\mathbb{D}}^n, r)$ defines a morphism of augmented non-unitary Λ -sequences, when we take this definition of Λ -sequence structure on the configuration spaces $F(\mathring{\mathbb{D}}^n, r)$. \square

We now examine the topological structure of the configuration spaces $F(\mathring{\mathbb{D}}^n, r)$ with the aim of determining the cohomology of these spaces. We begin with the following simple observation:

PROPOSITION 4.2.4. *We have a homotopy equivalence $F(\mathring{\mathbb{D}}^n, 2) \xrightarrow{\sim} \mathbb{S}^{n-1}$, between the configuration space of two points $F(\mathring{\mathbb{D}}^n, 2)$ and the $n - 1$ -sphere \mathbb{S}^{n-1} .*

PROOF. We easily check that the mapping which associates the normalized vector $\vec{ab}/\|\vec{ab}\| \in \mathbb{S}^{n-1}$ to each pair $(a, b) \in F(\mathring{\mathbb{D}}^n, 2)$ defines a homotopy equivalence. \square

4.2.5. *The definition of fundamental classes.* For $n > 1$, the result of Proposition 4.2.4 implies that we have:

$$\mathbb{H}_*(F(\mathring{\mathbb{D}}^n, 2)) = \mathbb{H}_*(\mathbb{S}^{n-1}) = \begin{cases} \mathbb{k}, & \text{if } * = 0, n - 1, \\ 0, & \text{otherwise,} \end{cases}$$

and similarly for the cohomology $\mathbb{H}^*(F(\mathring{\mathbb{D}}^n, 2))$. We use the notation $[\mathbb{S}^{n-1}]$ the fundamental class of the sphere (equipped with a suitable orientation) which defines a generator of the module $\mathbb{H}_{n-1}(\mathbb{S}^{n-1})$, and which we transport to $\mathbb{H}_*(F(\mathring{\mathbb{D}}^n, 2))$ by using the homotopy equivalence of Proposition 4.2.4. We will also use the notation $[pt]$ for the canonical generator of the degree 0 component of the homology module $H_*(F(\mathring{\mathbb{D}}^n, 2))$. In the cohomological context, we consider the element $\omega \in \mathbb{H}^{n-1}(F(\mathring{\mathbb{D}}^n, 2))$, dual to $[\mathbb{S}^{n-1}]$, in order to obtain a canonical generator of $\mathbb{H}^{n-1}(F(\mathring{\mathbb{D}}^n, 2))$.

Let now $r \geq 2$. For each pair $1 \leq i < j \leq r$, we consider the map $\phi_{ij} : F(\mathring{\mathbb{D}}^n, r) \rightarrow F(\mathring{\mathbb{D}}^n, 2)$ such that $\phi_{ij}(a_1, \dots, a_r) = (a_i, a_j)$, and we set $\omega_{ij} = \phi_{ij}^*(\omega)$ for the image of $\omega \in \mathbb{H}^{n-1}(F(\mathring{\mathbb{D}}^n, 2))$ under the morphism $\phi_{ij}^* : \mathbb{H}^{n-1}(F(\mathring{\mathbb{D}}^n, 2)) \rightarrow \mathbb{H}^{n-1}(F(\mathring{\mathbb{D}}^n, r))$ induced by this map. Observe that ϕ_{ij} is the restriction operation associated with the injection $\rho_{ij} : \{1 < 2\} \rightarrow \{1 < \dots < r\}$ such that $\rho_{ij}(1) = i$ and $\rho_{ij}(2) = j$.

Let $\mathbb{S}(\omega_{ij}, i < j)$ be the graded symmetric algebra generated by the classes ω_{ij} in degree $n - 1$. We have the following result:

THEOREM 4.2.6 (See V. Arnold [7], F. Cohen [40]). *Let $n > 1$. Let $r \geq 2$.*

- (a) *In $\mathbb{H}^*(F(\mathring{\mathbb{D}}^n, r))$, we have the relation $\omega_{ij}^2 = 0$ for each pair $i < j$, and the relation $\omega_{ij}\omega_{jk} - \omega_{ik}\omega_{jk} - \omega_{ij}\omega_{ik} = 0$ for each triple $i < j < k$.*
- (b) *The morphism $\mathbb{S}(\omega_{ij}, i < j) \rightarrow \mathbb{H}^*(F(\mathring{\mathbb{D}}^n, r))$, mapping the generator ω_{ij} to the corresponding cohomology class in $\mathbb{H}^*(F(\mathring{\mathbb{D}}^n, r))$, induces an isomorphism*

$$\frac{\mathbb{S}(\omega_{ij}, i < j)}{(\omega_{ij}^2, \omega_{ij}\omega_{jk} - \omega_{ik}\omega_{jk} - \omega_{ij}\omega_{ik})} \xrightarrow{\cong} \mathbb{H}^*(F(\mathring{\mathbb{D}}^n, r)),$$

when we form the quotient of the symmetric algebra $\mathbb{S}(\omega_{ij}, i < j)$ by the ideal generated by the relations of (a). \square

This theorem is established in the cited references, by using euclidean spaces \mathbb{R}^n instead of open discs $\mathring{\mathbb{D}}^n$. This choice does not change the result since the homeomorphism between the euclidean n -space \mathbb{R}^n and the open n -disc $\mathring{\mathbb{D}}^n$ induces a homeomorphism at the configuration space level.

In the case $n = 2$, we can still use the complex plane \mathbb{C} instead of \mathbb{R}^2 . This case $n = 2$ of the theorem is addressed in the reference [7], by using the differential form $d \log(z_i - z_j)$ as a representative of the class ω_{ij} in the de Rham complex of the configuration space $F(\mathbb{C}, r) = \{(z_1, \dots, z_r) \in \mathbb{C}^r \mid z_i \neq z_j\}$, where we take the complex field as coefficient ring. The general case of the theorem is addressed in the reference [40]. The computation involves the Leray-Serre spectral sequences associated to the projection map

$$f : F(\mathbb{R}^n, r) \rightarrow F(\mathbb{R}^n, r - 1)$$

which forgets about the last point of a configuration. We also refer to the article [158] provides a comprehensive survey, with little background, of this homological computation.

We use the result of Theorem 4.2.6 (in this form) when we study the commutative algebra part of the deformation complex of E_2 -operads. We also need to determine the morphisms $\partial_k^* : \mathbb{H}^*(F(\mathring{\mathbb{D}}^n, r - 1)) \rightarrow \mathbb{H}^*(F(\mathring{\mathbb{D}}^n, r))$ induced by the map $\partial_k : F(\mathring{\mathbb{D}}^n, r) \rightarrow F(\mathring{\mathbb{D}}^n, r - 1)$ such that $\partial_k(a_1, \dots, a_r) = (a_1, \dots, \widehat{a_k}, \dots, a_r)$, for any $\underline{a} = (a_1, \dots, a_r) \in F(\mathring{\mathbb{D}}^n, r)$. These maps are the restriction operations associated to the usual generating morphisms $\partial^k : \{1 < \dots < r - 1\} \rightarrow \{1 < \dots < r\}$ of the category Λ in Proposition 4.2.3. We have the following easy result:

PROPOSITION 4.2.7. *Let $n > 1$ again. The morphism $\partial_k^* : \mathbb{H}^*(F(\mathring{\mathbb{D}}^n, r - 1)) \rightarrow \mathbb{H}^*(F(\mathring{\mathbb{D}}^n, r))$, for any $r \in \mathbb{N}$, and any $k = 1, \dots, r$, satisfies*

$$\partial_k^*(\omega_{ij}) = \begin{cases} \omega_{ij}, & \text{if } i \neq j \neq k, \\ 0, & \text{otherwise,} \end{cases}$$

for each generating cohomology class ω_{ij} , $1 \leq i < j \leq r$, of the cohomology algebra $\mathbb{H}^*(F(\mathring{\mathbb{D}}^n, r))$.

PROOF. Exercise. \square

4.2.8. Homology and monoidal structures. We can use the existence of a cohomology isomorphism $\omega^* : \mathbb{H}^*(F(\mathring{\mathbb{D}}^n, r)) \xrightarrow{\cong} \mathbb{H}^*(D_n(r))$ and the duality pairing

$$\mathbb{H}^*(F(\mathring{\mathbb{D}}^n, r)) \otimes \mathbb{H}_*(D_n(r)) \xrightarrow{\cong} \mathbb{H}^*(F(\mathring{\mathbb{D}}^n, r)) \otimes \mathbb{H}_*(F(\mathring{\mathbb{D}}^n, r)) \xrightarrow{\langle -, - \rangle} \mathbb{k}$$

to determine the homology of each component of the little n -discs operad from our description of the cohomology of the configuration spaces in Theorem 4.2.6. But we now aim to give a description of the collection of homology modules $\{\mathbb{H}_*(D_n(r))\}$ as an operad.

We have already used that the cohomology defines a functor from spaces to commutative algebras. We carefully check the definition of a coalgebra structure on the homology of spaces first, and we address the general definition of operadic structures on the homology of operads before tackling the case of little n -discs. We use the formalism of symmetric monoidal functors (see §2.3.1).

We obviously have $H_*(pt) = \mathbb{k}$, by definition of ordinary homology, so that the mapping $H_* : X \mapsto H_*(X)$ defines a unit pointed functor from topological spaces to graded modules. We consider the Künneth morphism $\kappa : H_*(X) \otimes H_*(Y) \rightarrow H_*(X \times Y)$. We have the following classical statement:

PROPOSITION 4.2.9 (See [121, §VIII] or [161, §5.3]).

- (a) *The Künneth morphism defines a symmetric monoidal transformation on the homology functor $H_* : X \mapsto H_*(X)$, regarded as a functor from the symmetric monoidal category of spaces \mathcal{Top} towards the symmetric monoidal category of graded modules $gMod$.*
- (b) *If the coefficient ring is a field, then the Künneth morphism is an iso, so that the homology defines a symmetric monoidal functor $H_* : \mathcal{Top} \rightarrow gMod$. \square*

We can therefore apply the general constructions of §2.0.4 to obtain:

PROPOSITION 4.2.10. *If the coefficient ring is a field, then the homology functor $H_* : \mathcal{Top} \rightarrow gMod$ induces a functor from the category of topological spaces \mathcal{Top} towards the category of counitary cocommutative coalgebras in graded modules $gCom_+^c$, and this functor $H_* : \mathcal{Top} \rightarrow gCom_+^c$ is also symmetric monoidal.*

EXPLANATIONS. In §2.0.4, we deal with the general case of a functor between symmetric monoidal categories. In the context of Proposition 4.2.10, we consider the homology functor $H_* : \mathcal{Top} \rightarrow gMod$ between topological spaces and graded modules. The first result of that proposition, the existence of a counitary cocommutative coalgebra structure on the homology, follows from Proposition 4.2.9 and the observation that any space X naturally forms a counitary cocommutative coalgebra in the category of spaces, with the constant map $\epsilon : X \rightarrow pt$ as counit, and the diagonal map $\Delta : X \rightarrow X \times X$ as coproduct. The second result of the proposition, the definition of the symmetric monoidal functor $H_* : \mathcal{Top} \rightarrow gCom_+^c$, arises from the observations of §2.0.4.

To prepare our subsequent study of the homology of little discs, we examine this applications of the general construction of §2.0.4 with more details. First, the graded counitary cocommutative coalgebra structure on the homology of a space $H_*(X)$ is formed as follows:

- (a) To define the counit of this coalgebra, we simply consider the morphism $H_*(X) \rightarrow H_*(pt) = \mathbb{k}$, associated to the constant map $X \rightarrow pt$;
- (b) To define the coproduct, we form the composite

$$H_*(X) \xrightarrow{\Delta_*} H_*(X \times X) \xleftarrow{\cong} H_*(X) \otimes H_*(X),$$

where we consider the morphism induced by the diagonal of the space X , followed by the Künneth isomorphism.

The unit, associativity and symmetry constraints, fulfilled by the Künneth isomorphism, ensures that the obtained coalgebra structure satisfies the counit, coassociativity, and cocommutativity relations of graded counitary cocommutative coalgebras (see §2.0.4).

The coproduct on the homology represents the dual morphism of the product $\mu : H^*(X) \otimes H^*(X) \rightarrow H^*(X)$, defining the commutative algebra structure of the cohomology $H^*(X)$, because this product can also be defined as a composite

$$H^*(X) \otimes H^*(X) \xrightarrow{\kappa^*} H^*(X \times X) \xrightarrow{\Delta^*} H^*(X),$$

where we consider a cohomological version of the Künneth morphism, followed by the morphism induced by the diagonal of the space X . Note that the commutative algebra structure of the cohomology is still defined when the Künneth morphism is not an iso (in contrast with the coalgebra structure of the homology). To give a more explicit formulation of this duality between product and coproduct, we consider the natural pairing $\langle -, - \rangle : \mathbb{H}^*(X) \otimes \mathbb{H}_*(X) \rightarrow \mathbb{k}$, between the cohomology and the homology of X . If we set $\Delta(c) = \sum_i a_i \otimes b_i$ for the coproduct of an element c in $\mathbb{H}_*(X)$, then we have the adjunction relation

$$\langle \alpha \cdot \beta, c \rangle = \sum_i \pm \langle \alpha, a_i \rangle \cdot \langle \beta, b_i \rangle,$$

for every $\alpha, \beta \in \mathbb{H}^*(X)$, where the sign \pm is produced by the commutation of the factors α and a_i in this expression.

The tensor product $\otimes : g\mathcal{C}om_+^c \times g\mathcal{C}om_+^c \rightarrow g\mathcal{C}om_+^c$ of the category of graded counitary cocommutative coalgebras is inherited from the category of graded modules by definition (see §2.0.3). The construction implies that the Künneth morphism $\mathbb{H}_*(X) \otimes \mathbb{H}_*(Y) \rightarrow \mathbb{H}_*(X \times Y)$ defines a morphism of graded counitary cocommutative coalgebras, and satisfies the unit, associativity, and symmetry constraints of §2.3.1 in that category $g\mathcal{C}om_+^c$ (see §2.0.4). Thus, improving on the assertion of Proposition 4.2.9, we finally obtain that the homology functor defines a symmetric monoidal functor $\mathbb{H}_* : \mathcal{T}op \rightarrow g\mathcal{C}om_+^c$, between spaces and graded counitary cocommutative coalgebras, as asserted in the proposition. \square

We then obtain:

PROPOSITION 4.2.11. *Let P be any operad in topological spaces.*

- (a) *The collection of graded modules $\mathbb{H}_*(P) = \{\mathbb{H}_*(P(r)), r \in \mathbb{N}\}$ associated to the spaces $P(r)$ forms a graded operad naturally associated to P , for any choice of ground ring.*
- (b) *If the ground ring is a field, then this operad $\mathbb{H}_*(P)$ is actually an operad in graded counitary cocommutative coalgebras, where we use Proposition 4.2.10 to get the coalgebra structure on the homology modules $\mathbb{H}_*(P(r))$.*

EXPLANATIONS. This proposition is a corollary of the results of §2.1, where we examine the image of operads under functors between symmetric monoidal categories. We consider the homology functor $\mathbb{H}_* : X \mapsto \mathbb{H}_*(X)$, from the category of spaces towards the category of graded modules (respectively, graded counitary cocommutative coalgebras), and we use the result of Lemma 2.1.3 to get the definition of an operad structure on the homology $\mathbb{H}_*(P)$. We obtain the following structures:

- (a) The morphisms $w_* : \mathbb{H}_*(P(r)) \rightarrow \mathbb{H}_*(P(r))$, induced by the action of permutations $w \in \Sigma_r$ at the topological level, give the action of permutations on the homology of the operad.
- (b) The morphism $\mathbb{k} = \mathbb{H}_*(pt) \xrightarrow{\eta_*} \mathbb{H}_*(P(1))$, induced by the operadic unit of the topological operad P , gives an operadic unit at the homology level.
- (c) The partial composition products of the topological operad P induce morphisms

$$\mathbb{H}_*(P(m)) \otimes \mathbb{H}_*(P(n)) \rightarrow \mathbb{H}_*(P(m) \times P(n)) \xrightarrow{(\circ_i)_*} \mathbb{H}_*(P(m+n-1))$$

which give the partial composition products of the homology operad $\mathbb{H}_*(P)$.

The unit, associativity and symmetry constraints of symmetric monoidal functors ensures that these structure morphisms fulfills the equivariance, unit and associativity axioms of operads (see §2.1). Depending on the context (a-b), we can form the morphisms giving this operad structure in the category of graded modules or in the category of counitary cocommutative coalgebras.

To complete this analysis, recall that such a functor on operads $\mathbb{H}_* : P \mapsto \mathbb{H}_*(P)$ preserves unitary extensions: we have the identity $\mathbb{H}_*(P_+) = \mathbb{H}_*(P)_+$ for any unitary extension P_+ of a non-unitary operad P . \square

Following the conventions of §2.2, we will use the terminology of graded Hopf operad to refer to an operad in augmented graded commutative coalgebras, and the notation $g\mathcal{H}opfOp$ (instead of $g\mathcal{C}om_+^c Op$) for the category formed by these operads. We similarly use the terminology of graded Hopf symmetric sequence, and the notation $g\mathcal{H}opfSeq$, for the category of symmetric sequence in graded counitary cocommutative coalgebras. Proposition 4.2.11(b) asserts, under these conventions, that the homology functor $\mathbb{H}_* : \mathcal{T}op \rightarrow g\mathcal{C}om_+^c$ induces a functor $\mathbb{H}_* : \mathcal{T}opOp \rightarrow g\mathcal{H}opfOp$.

For $P = D_1$ (respectively, $P = D_\infty$), the existence of a weak-equivalences between our operad and the discrete operad of associative (respectively, commutative) monoids implies:

PROPOSITION 4.2.12.

- (a) *We have an identity of graded Hopf operads $\mathbb{H}_*(D_1) = \mathbf{As}$, where we consider the associative operads in \mathbb{k} -modules \mathbf{As} , regarded as a graded operad concentrated in degree 0, together with the coproduct inherited from the corresponding set operad (see the concluding paragraph of §2.1). In the unitary setting, we have similarly $\mathbb{H}_*(D_{1+}) = \mathbf{As}_+$.*
- (b) *We have an identity of graded Hopf operads $\mathbb{H}_*(D_\infty) = \mathbf{Com}$, where we consider the commutative operads in \mathbb{k} -modules \mathbf{Com} , regarded as a graded operad concentrated in degree 0, together with the coproduct inherited from the corresponding set operad (see the concluding paragraph of §2.1 again). In the unitary setting, we have similarly $\mathbb{H}_*(D_{\infty+}) = \mathbf{Com}_+$.*

Recall that our main objective is to give the description of $\mathbb{H}_*(D_n)$ as a graded Hopf operad when $1 < n < \infty$. We give an abstract definition of this sequence of graded Hopf operads first and we explain the identity with the homology of little discs afterwards.

4.2.13. *The Gerstenhaber operad.* We use the notation \mathbf{Gerst}_n , and the terminology of n -Gerstenhaber operad, for the n th term of this sequence of graded Hopf operads, which we now consider. This graded Hopf operad \mathbf{Gerst}_n is actually a graded versions of the Poisson operad of §1.2.12, and some authors use the name of Poisson operad of degree $n - 1$, rather than n -Gerstenhaber operad. We precisely define \mathbf{Gerst}_n by the same presentation as the Poisson operad

$$\begin{aligned} \mathbf{Gerst}_n = \mathcal{O}(\mathbb{k}\mu(x_1, x_2) \oplus \mathbb{k}\lambda(x_1, x_2)) : \\ \mu(\mu(x_1, x_2), x_3) \equiv \mu(x_1, \mu(x_2, x_3)), \\ \lambda(\lambda(x_1, x_2), x_3) + \lambda(\lambda(x_2, x_3), x_1) + \lambda(\lambda(x_3, x_1), x_2) \equiv 0, \\ \lambda(\mu(x_1, x_2), x_3) \equiv \mu(\lambda(x_1, x_3), x_2) + \mu(x_1, \lambda(x_2, x_3)) \end{aligned}$$

with a generating operation $\mu = \mu(x_1, x_2)$ of degree 0 and such that $(1\ 2) \cdot \mu = \mu$, but where we now assume that $\lambda = \lambda(x_1, x_2)$ is a generating operation of degree $n-1$, satisfying a symmetry relation $(1\ 2) \cdot \lambda = (-1)^n \lambda$ that depends on the degree n of the operad.

The operation μ forms associative and commutative product in Gerst_n which generates as suboperad isomorphic to the commutative operad Com within the n -Gerstenhaber operad (see [73, 126]). The operation λ is a graded analogue of Lie bracket. The suboperad of Gerst_n generated by λ is isomorphic to a suspension of the Lie operad Lie (see [73]).

The distribution relation $\lambda(\mu(x_1, x_2), x_3) = \mu(\lambda(x_1, x_3), x_2) + \mu(x_1, \lambda(x_2, x_3))$ implies, as in the Poisson case, that any composite of products and Lie bracket in the n -Gerstenhaber operad is equal to a product of Lie monomials. To be more precise, one can prove that the components of the operad $\mathit{Gerst}_n(r)$ are the \mathbb{k} -modules spanned by formal products

$$p(x_1, \dots, x_r) = p_1(x_{11}, \dots, x_{1r_1}) \cdot \dots \cdot p_m(x_{m1}, \dots, x_{mr_m}),$$

where each $p_i = p_i(x_{i1}, \dots, x_{ir_i})$ is a Lie monomial of degree 1 with respect to each variable x_{ik} , $k = 1, \dots, r_i$, and so that the variable subsets $\{x_{i1}, \dots, x_{ir_i}\}$ form a partition of $\{x_1, \dots, x_r\}$. We simply have to consider operadic composites of the graded Lie bracket λ when we form our Lie monomials. The description of the Lie operad in §1.2.10, remains also valid in this context, and any monomial $p_i = p_i(x_{i1}, \dots, x_{ir_i})$ in the above expansion has a reduced form

$$p_i(x_{i1}, \dots, x_{ir_i}) = \lambda(\dots \lambda(\lambda(x_{i1}, x_{i2}), x_{i3} \dots), x_{ir_i}),$$

where we assume $x_{i1} < x_{ik}$, for all $1 < k$ (with respect to the natural ordering inherited from the set of variables $\{x_1 < \dots < x_r\}$).

We provide the operad Gerst_n with a Hopf structure such that $\epsilon(\mu) = 1$ and $\Delta(\mu) = \mu \otimes \mu$, for the commutative product operation $\mu \in \mathit{Gerst}_n(2)$ and $\epsilon(\lambda) = 1$ and $\Delta(\lambda) = \lambda \otimes \mu + \mu \otimes \lambda$ for the Lie bracket operation $\lambda \in \mathit{Gerst}_n(2)$. We can readily see, as in the Poisson case (see §2.2.12), that the ideal of generating relations forms a Hopf ideal, so that this Hopf structure is well defined.

4.2.14. *The unitary Gerstenhaber operad.* We have considered a non-unitary version of the n -Gerstenhaber operad in the construction of the previous paragraph. We can also define a unitary n -Gerstenhaber operad, by observing, as in the Poisson case, that the operad Gerst_n inherits a restriction structure such that $\partial_1 \mu = \partial_2 \mu = 1$ and $\partial_1 \lambda = \partial_2 \lambda = 0$ for the generating operations $\mu, \lambda \in \mathit{Gerst}_n(2)$. We easily check that the application of these restriction operations cancel the generating relations of Gerst_n . We then use the process of §3.4.8 to obtain the definition of our unitary extension Gerst_{n+} of the operad Gerst_n .

The Hopf structure of the n -Gerstenhaber operad is clearly preserved by our restriction operations so that our construction yields a unitary extension of the n -Gerstenhaber operad in the category of Hopf operads.

In the computation of the homology of the operad of little discs, we use the restriction morphisms, associated with this unitary extension of the Gerstenhaber operad, as well as the Hopf structure. The main result reads:

THEOREM 4.2.15 (F. Cohen [40]). *Let $n > 1$.*

- (a) *The elements $\mu = [pt] \in \mathbb{H}_0(D_n(2))$ and $\lambda = [\mathbb{S}^{n-1}] \in \mathbb{H}_{n-1}(D_n(2))$ satisfy the symmetry relations $(1\ 2) \cdot \mu = \mu$ and $(1\ 2) \cdot \lambda = \lambda$ as well as the*

generating relations of the Poisson operad

$$\begin{aligned}\mu(\mu(x_1, x_2), x_3) &= \mu(x_1, \mu(x_2, x_3)), \\ \lambda(\lambda(x_1, x_2), x_3) + \lambda(\lambda(x_2, x_3), x_1) + \lambda(\lambda(x_3, x_1), x_2) &= 0, \\ \lambda(\mu(x_1, x_2), x_3) &= \mu(\lambda(x_1, x_3), x_2) + \mu(x_1, \lambda(x_2, x_3))\end{aligned}$$

in the homology of the little n -discs.

- (b) The counit and coproduct of our elements on the homology of the space $D_n(2)$ are given by:

$$\begin{aligned}\epsilon[pt] &= 1, \quad \Delta[pt] = [pt] \otimes [pt], \\ \epsilon[\mathbb{S}^{n-1}] &= 0, \quad \Delta[\mathbb{S}^{n-1}] = [\mathbb{S}^{n-1}] \otimes [pt] + [pt] \otimes [\mathbb{S}^{n-1}].\end{aligned}$$

The restriction operations $\partial_k : \mathbb{H}_*(D_n(2)) \rightarrow \mathbb{H}_*(D_n(1))$, $k = 1, 2$, which the homology module $\mathbb{H}_*(D_n(2))$ inherits from the little n -discs operad, are determined by:

$$\partial_1[pt] = \partial_2[pt] = 1, \quad \partial_1[\mathbb{S}^{n-1}] = \partial_2[\mathbb{S}^{n-1}] = 0,$$

where we use the obvious identity $\mathbb{H}_*(D_n(1)) = \mathbb{H}_*(F(\mathbb{D}^n, 1)) = \mathbb{k}$.

- (c) The mapping $\mu \mapsto [pt] \in \mathbb{H}_0(D_n(2))$ and $\lambda \mapsto [\mathbb{S}^{n-1}] \in \mathbb{H}_{n-1}(D_n(2))$ induces an isomorphism of graded Hopf operads

$$h : \mathbf{Gerst}_n \xrightarrow{\cong} \mathbb{H}_*(D_n),$$

which also admits a unitary extension $h_+ : \mathbf{Gerst}_{n+} \xrightarrow{\cong} \mathbb{H}_*(D_{n+})$.

EXPLANATIONS AND REFERENCES. We refer to [40] for the proof of the identities of (a) in the homology of the little discs operad (see also [158] for another nice reference on this topic). The identities of (b) are obvious.

We deduce, after this preliminary verification, that we have a morphism of graded operads $h : \mathbf{G}_n \rightarrow \mathbb{H}_*(D_n)$ mapping the generating operation $\mu \in \mathbf{Gerst}_n(2)$ (respectively, $\lambda \in \mathbf{Gerst}_n(2)$) to the element $[pt] \in \mathbb{H}_0(D_n(2))$ (respectively $[\mathbb{S}^{n-1}] \in \mathbb{H}_{n-1}(D_n(2))$), as specified in the theorem. As the coproduct of the homology classes $[pt]$ and $[\mathbb{S}^{n-1}]$ matches the definition of the coproduct of the corresponding generating operations in the Gerstenhaber operad, we immediately conclude that coproducts are preserved by our morphism, which therefore forms a morphism of graded Hopf operads.

We still have to check that this morphism is an iso. We can deduce this claim from the computation of the cohomology of configuration spaces in Theorem 4.2.6, and from the next proposition, which involves the definition of the morphism (and no more). We refer to [158] for details.

The result of the theorem also follows from the computation of [40], giving the expression of the homology $\mathbb{H}_*(S_*(D_n, X))$ as a functor in $\mathbb{H}_*(X)$, for any space X , where $S_*(D_n, X)$ refers to the free D_n -algebra associated to X modulo base point (see *loc. cit.* for details). In the case of rational coefficients, the result of [40] asserts that this functor is precisely the free \mathbf{Gerst}_n -algebra on $\mathbb{H}_*(X)$, and the identity between \mathbf{Gerst}_n and $\mathbb{H}_*(D_n)$ is actually equivalent to this functor identity.

The preservation of restriction morphisms implies that our morphism h extends to a morphism of unitary operads h_+ which is obviously an iso too as soon as h is. \square

PROPOSITION 4.2.16. *Let $\omega_{ij} \in \mathbb{H}^*(F(\mathring{\mathbb{D}}^n, r))$ be any of the generating elements of the cohomology algebra $\mathbb{H}^*(F(\mathring{\mathbb{D}}^n, r))$, as defined in §4.2.5. Let $p = p(x_1, \dots, x_r) \in \mathit{Gerst}_n(r)$. We apply the morphism of Theorem 4.2.15 to regard p as an element of $\mathbb{H}_*(D_n(r))$. Then we have the duality relation*

$$\langle \omega_{ij}, p \rangle = \begin{cases} 1, & \text{in the case } p = x_1 \cdots \lambda(x_i, x_j) \cdots \hat{x}_j \cdots x_r, \\ 0, & \text{otherwise,} \end{cases}$$

with respect the pairing $\langle \cdot, \cdot \rangle : \mathbb{H}_*(F(\mathring{\mathbb{D}}^n, r)) \otimes \mathbb{H}_*(D_n(r)) \rightarrow \mathbb{k}$ considered in §4.2.8.

PROOF. We use that the disc center map $\omega : D_n(r) \rightarrow F(\mathring{\mathbb{D}}^n, r)$ defines a weak-equivalence of non-unitary Λ -sequences. We have by definition $\omega_{ij} = \phi_{ij}^*(\omega)$, where $\omega \in \mathbb{H}^{n-1}(F(\mathring{\mathbb{D}}^n, 2))$ is the dual element of the class $[\mathbb{S}^{n-1}]$ which represents the Lie bracket operation $\lambda = \lambda(x_1, x_2)$ in $\mathbb{H}_*(D_n)$. Recall that the map $\phi_{ij} : F(\mathring{\mathbb{D}}^n, r) \rightarrow F(\mathring{\mathbb{D}}^n, 2)$, considered in the definition of this element ω_{ij} , is the restriction operation associated to the mapping $\rho_{ij} : \{1 < 2\} \rightarrow \{1 < \dots < r\}$ such that $\rho(1) = i$ and $\rho(2) = j$. By functoriality of the pairing between cohomology and homology, and the preservation of restriction morphisms, we obtain:

$$\langle \omega_{ij}, p \rangle = \langle (\phi_{ij})^*(\omega), p \rangle = \langle \omega, (\rho_{ij})^*(p) \rangle$$

for any $p = p(x_1, \dots, x_r) \in \mathit{Gerst}_n(r)$. The result of the proposition accordingly follows from the expression of the expression of restriction operations on products of Lie monomials in the Gerstenhaber operad §4.2.13, and from the duality formula $\langle \omega, \lambda \rangle = 1$. \square

The expression of the pairing $\langle \pi, p \rangle$ associated to any monomial $\pi = \omega_{i_1 j_1} \cdots \omega_{i_r j_r}$ can be obtained from the result of this proposition, and the adjunction relation between the product of $\mathbb{H}^*(F(\mathring{\mathbb{D}}^n, r))$ and the coproduct of $\mathbb{H}_*(D_n(r))$ (see §4.2.8). The combinatorial formula arising from this process is worked out in [158], and implies that our construction yields a non-degenerate pairing in each arity $r \in \mathbb{N}$, between the component of the n -Gerstenhaber operad $G_n(r)$ and the cohomology algebra of Theorem 4.2.6. This argument provides a proof that the map of Theorem 4.2.15 defines an iso between the n -Gerstenhaber operad and the homology of the little n -discs operad (as we mention in the proof of this statement).

4.3. Outlook: variations on the little discs operads

The little n -discs operad of §4.1 is our reference model of E_n -operad, and we mostly deal with structures which we directly obtain from the consideration of this topological object. Nonetheless, this operad is not universal. We have other instances of E_n -operads and, depending on the considered application, one model of E_n -operad may be more appropriate than another. We may also consider additional structures in our definition in order to get variants of the notion of an E_n -operad. The purpose of this section is to give an overview of geometric constructions yielding such operads related to little discs.

In the first instance, we provide an outline of the definition of the Fulton-MacPherson operad FM_n , an instance of E_n -operad introduced by E. Getzler and J. Jones in [73], and which arises from a compactification of the configuration space of points in the euclidean space $F(\mathbb{R}^n, r)$. We may intuitively regard a configuration of points as a configuration of discs equipped with a zero radius. The idea of the Fulton-MacPherson operad is to use the compactification process in order to extend

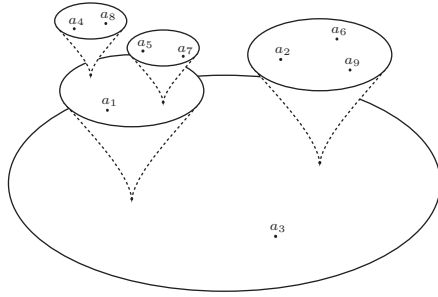

FIGURE 4.5. The picture of an element in the Fulton-MacPherson compactification of the configuration space.

the composition of little discs to this degenerate case. We then obtain a picture of the form of Figure 4.5, involving a scale of microscopic configurations, forming a tree, and which represent a free operadic composite in our compactification. We outline the definition of the topological spaces underlying this operad structure first.

4.3.1. *The Fulton-MacPherson compactifications.* In the approach of the reference [73], we first consider a compactified space $\overline{F}(\mathbb{R}^n, r)$, for each $r \in \mathbb{N}$, defined by performing real blow-ups of the diagonal subspaces $x_{i_1} = x_{i_2} = \dots = x_{i_k}$ in the product space $(\mathbb{R}^n)^r$, and by taking the closure of $F(\mathbb{R}^n, r)$ in the cartesian product of all these blow-up spaces. This compactification process is a real analogue of the construction introduced by Fulton-MacPherson in [62], for the study of configuration spaces of points in complex varieties. The real version of the compactification process was initially introduced by Axelrod-Singer in [11], for the study of the perturbative expansion of Chern-Simons quantum field theories.

In short, the real blow-up of the small diagonal $\Delta = \{x_1 = x_2 = \dots = x_k\}$ in a product space $(\mathbb{R}^n)^k$ is a space $\text{Bl}_\Delta(\mathbb{R}^n)^k \subset (\mathbb{R}^n)^k \times (\mathbb{R}^n)^k$ such that:

- the mapping

$$\pi : \text{Bl}_\Delta(\mathbb{R}^n)^k \rightarrow (\mathbb{R}^n)^k,$$

induced by the projection $\pi(x_1, \dots, x_k, v_1, \dots, v_k) = (x_1, \dots, x_k)$, is one-to-one over the complement of the diagonal Δ in $(\mathbb{R}^n)^k$,

- and we have

$$\pi^{-1}(a, \dots, a) = \{(a, \dots, a)\} \times ((\Delta^\perp \setminus 0) / \mathbb{R}_{>0}),$$

for the points of the diagonal $(a, \dots, a) \in \Delta$, where $(\Delta^\perp \setminus 0) / \mathbb{R}_{>0}$ is the space of open half lines $\mathbb{R}_{>0} v$ in the vector space $\Delta^\perp = \{x_1 + x_2 + \dots + x_k = 0\}$.

The spaces $\overline{F}(\mathbb{R}^n, r)$ returned by the real Fulton-MacPherson compactification process are manifolds with corners. The canonical embeddings $F(\mathbb{R}^n, r) \hookrightarrow \overline{F}(\mathbb{R}^n, r)$ also define weak-equivalences of topological spaces. We refer to the cited articles [11, 62], or to [149], for further details on the construction of these spaces $\overline{F}(\mathbb{R}^n, r)$.

The configuration space $F(\mathbb{R}^n, r)$ inherits an action of the group $\mathbb{R}_{>0} \times \mathbb{R}^n$ consisting of the transformations of the euclidean space \mathbb{R}^n such that

$$\phi : (x_1, \dots, x_n) \mapsto \lambda \cdot (x_1, \dots, x_n) + (a_1, \dots, a_n),$$

CO

where $\lambda \in \mathbb{R}_{>0}$, $(a_1, \dots, a_n) \in \mathbb{R}^n$. The Fulton-MacPherson compactification process can be performed equivariantly in order to get a compactification $\overline{C}(\mathbb{R}^n, r)$ of the quotient space $C(\mathbb{R}^n, r) = F(\mathbb{R}^n, r)/\mathbb{R}_{>0} \times \mathbb{R}^n$. The spaces $\overline{C}(\mathbb{R}^n, r)$ have the structure of manifolds with corners, like $\overline{F}(\mathbb{R}^n, r)$, and the composite map $F(\mathbb{R}^n, r) \rightarrow C(\mathbb{R}^n, r) \hookrightarrow \overline{C}(\mathbb{R}^n, r)$ defines a weak-equivalence too (we refer to [149] for a detailed proof of this assertion).

4.3.2. *The Fulton-MacPherson operad.* The spaces $FM_n(r) = \overline{C}(\mathbb{R}^n, r)$ form the underlying collection of the Fulton-MacPherson operad FM_n . The structure of this operad is defined as follows. To start with, we immediately see that the symmetric group Σ_r acts on $FM_n(r)$, for each r , so that our collection of spaces forms a symmetric sequence. We also have $FM_n(1) = pt$, so that FM_n inherits a canonical operadic unit too.

Let $FM_n(r) = C(\mathbb{R}^n, r) = F(\mathbb{R}^n, r)/\mathbb{R}_{>0} \times \mathbb{R}^n$. We explain the definition of operadic composites in the case of (equivariance classes of) configurations of points $\underline{a} = (a_1, \dots, a_r) \in F(\mathbb{R}^n, r)$ and $\underline{b} = (b_1, \dots, b_s) \in F(\mathbb{R}^n, s)$ defining elements in these inner subspaces $FM_n(-)$ of the Fulton-MacPherson operad $FM_n(-) = \overline{C}(\mathbb{R}^n, -)$. We can assume $a_1 + \dots + a_r = 0$ and $b_1 + \dots + b_s = 0$ by equivariance with respect the action of translations. We define the operadic composite $\underline{a} \circ_k \underline{b}$ in $FM_n(r+s-1) = \overline{C}(\mathbb{R}^n, r+s-1)$ by considering the element

$$(a_k, \dots, a_k) \times (b_1, \dots, b_s) \in \{(a_k, \dots, a_k)\} \times ((\Delta^\perp \setminus 0)/\mathbb{R}_{>0})$$

in the blow-up of the subspace $x_k = x_{k+1} = \dots = x_{k+s-1}$, and by taking $x_1 = a_1, \dots, x_{k-1} = a_{k-1}, x_{k+s} = a_{k+1}, \dots, x_{r+s-1} = a_r$ for the remaining components of our point.

This process has a natural extension to the whole spaces $FM_n(-) = \overline{C}(\mathbb{R}^n, -)$ and returns well-defined operadic composition operations $\circ_k : FM_n(r) \times FM_n(s) \rightarrow FM_n(r+s-1)$, for all $r, s > 0$ and each $k = 1, \dots, r$.

We have already mentioned, in §4.3.1, that the spaces $FM_n(r)$ are weakly-equivalent to the configuration spaces $F(\mathbb{R}^n, r)$. Thus, we have weak-equivalences of spaces $D_n(r) \xrightarrow{\sim} F(\mathbb{R}^n, r) \xrightarrow{\sim} FM_n(r)$ between the little n -discs spaces $D_n(r)$ and the components of the Fulton-MacPherson operad. These maps do not form an operad morphism, but one can lift them to get an operad weak-equivalence $\mathbb{W}(D_n) \xrightarrow{\sim} FM_n$, where $\mathbb{W}(D_n)$ is the Boardman-Vogt construction of D_n (see [26]), an operad consisting of formal composites of little n -discs configuration, which we arrange on trees equipped with a metric structure. This operad $\mathbb{W}(D_n)$ is also equipped with a natural weak-equivalence $\mathbb{W}(D_n) \xrightarrow{\sim} D_n$ so that we have a chain of weak-equivalences of operads

$$D_n \xleftarrow{\sim} \mathbb{W}(D_n) \xrightarrow{\sim} FM_n$$

proving that the Fulton-MacPherson operad FM_n defines an instance of an E_n -operad. We refer to [149] for the explicit construction of the operad morphism $\mathbb{W}(D_n) \xrightarrow{\sim} FM_n$.

We have not been explicit about arity 0 terms in the construction of our operad FM_n . We tacitly assume that we deal with a non-unitary operad FM_n , so that $FM_n(0) = \emptyset$. But we also have an obvious extension of our operad construction in arity zero, and this extended construction naturally yields a unitary extension FM_{n+} of the non-unitary Fulton-MacPherson operad FM_n .

The Boardman-Vogt construction is a general construction used to define cofibrant resolutions of operads in the setting of model categories. We tackle this subject in §II.1.4. In the case of the Fulton-MacPherson operad, we actually have an isomorphism of topological operads $FM_n \simeq \mathbb{W}(FM_n)$, and deduce from this relation that the Fulton-MacPherson operad forms a cofibrant model of E_n -operad (see [149]).

4.3.3. *Trees and the underlying structure of the Fulton-MacPherson operad.* The relation $FM_n \simeq \mathbb{W}(FM_n)$ mentioned in the previous paragraph implies that the operad FM_n is free as an operad in sets. If we forget about the topology, then we can actually identify the Fulton-MacPherson operad FM_n with the free operad generated by the symmetric sequence $\mathring{FM}_n(r)$. This free operad structure reflects the geometry of the spaces $FM_n(r)$ in the blow-up construction of §4.3.1.

To be more explicit, one can observe that each space $FM_n(r)$ has a decomposition $FM_n(r) = \coprod_{\mathbb{T} \in \mathcal{T}_{ree}(r)} \mathring{FM}_n(\mathbb{T})$ of the same shape as the components of the free operad, where we use the formalism of the appendix chapter §II.A. Simply say for the moment that $\mathcal{T}_{ree}(r)$ denotes the category of r -trees, and the space $\mathring{FM}_n(\mathbb{T})$, is formed by a cartesian product

$$\mathring{FM}_n(\mathbb{T}) = \prod_{v \in V(\mathbb{T})} \mathring{FM}_n(\underline{r}_v),$$

representing an arrangement of factors $\mathring{FM}_n(\underline{r}_v)$ on the vertices $v \in V(\mathbb{T})$ of a tree \mathbb{T} .

The open space $\mathring{FM}_n(r) = C(\mathbb{R}^n, r) = F(\mathbb{R}^n, r) / \mathbb{R}_{>0} \times \mathbb{R}^n$, inside the compactification $FM_n(r) = \overline{C}(\mathbb{R}^n, r)$ is identified with the space $\mathring{FM}_n(\underline{Y})$ associated to the corolla:

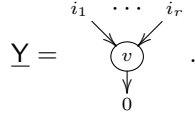

The operadic composite of configurations $\underline{a} = (a_1, \dots, a_r) \in F(\mathbb{R}^n, r)$ and $\underline{b} = (b_1, \dots, b_s) \in F(\mathbb{R}^n, s)$, of which we have made the definition explicit in §4.3.2, lies in the subspace $\mathring{FM}_n(\mathbb{T})$ associated to a tree with two vertices

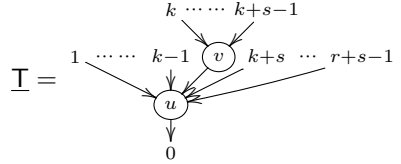

The spaces $\mathring{FM}_n(\mathbb{T})$, which we associate to r -trees \mathbb{T} such that $\sharp V(\mathbb{T}) \geq 2$, define the facets of the manifold with corners $FM_n(r) = \overline{C}(\mathbb{R}^n, r)$.

4.3.4. *Some variations on the Fulton-MacPherson compactification.* In [104], Kontsevich considers a simpler definition of compactifications from the quotients $C(\mathbb{R}^n, r) = F(\mathbb{R}^n, r) / \mathbb{R}_{>0} \times \mathbb{R}^n$ of the configuration spaces $F(\mathbb{R}^n, r)$. We refer to [66] for a detailed study of the relationship between Kontsevich’s approach and the blow-up construction of §4.3.1.

For each pair $i \neq j$, we consider the mapping $\theta_{ij} : C(\mathbb{R}^n, r) \rightarrow \mathbb{S}^{n-1}$ which sends the equivariance class of a configuration $\underline{a} = (a_1, \dots, a_r)$ to the unit vector

$$\theta_{ij}(a_1, \dots, a_r) = \frac{\overrightarrow{a_i a_j}}{\|\overrightarrow{a_i a_j}\|},$$

and, for each triple $i \neq j \neq k$, we consider the mapping $\delta_{ijk} : \mathcal{C}(\mathbb{R}^n, r) \rightarrow [0, \infty]$ such that:

$$\delta_{ijk}(a_1, \dots, a_r) = \|\overrightarrow{a_i a_j}\| / \|\overrightarrow{a_i a_k}\|.$$

We then consider the map

$$\iota : \mathcal{C}(\mathbb{R}^n, r) \rightarrow (\mathbb{S}^{n-1})^{\binom{r}{2}} \times [0, \infty]^{\binom{r}{3}}$$

such that $\iota(a_1, \dots, a_r) = ((\theta_{ij}(a_1, \dots, a_r))_{ij}, (\delta_{ijk}(a_1, \dots, a_r))_{ijk})$. We readily see that this map is an embedding. We can identify, according to [66], the compactification $\overline{\mathcal{C}}(\mathbb{R}^n, r)$ of §4.3.1 with the closure of the image of the space $\mathcal{C}(\mathbb{R}^n, r)$ in the product space $(\mathbb{S}^{n-1})^{\binom{r}{2}} \times [0, \infty]^{\binom{r}{3}}$.

We have a variant of this construction defined by considering the closure of the image the space $\mathcal{C}(\mathbb{R}^n, r)$ under the map

$$\iota^\sim : \mathcal{C}(\mathbb{R}^n, r) \rightarrow (\mathbb{S}^{n-1})^{\binom{r}{2}}$$

such that $\iota(a_1, \dots, a_r) = (\theta_{ij}(a_1, \dots, a_r))_{ij}$. Let $\overline{\mathcal{C}}(\mathbb{R}^n, r)^\sim$ be the space obtained by this compactification construction. We still have an operad structure, which is studied in details in [156], on the collection of the spaces $FM_n(r)^\sim = \overline{\mathcal{C}}(\mathbb{R}^n, r)^\sim$. We see however that the map ι^\sim is not injective, and therefore, the space $FM_n(r)^\sim = \overline{\mathcal{C}}(\mathbb{R}^n, r)^\sim$ differs from the previously considered compactification $FM_n(r) = \overline{\mathcal{C}}(\mathbb{R}^n, r)$.

Kontsevich is not precise about the operads used in his work. In [104], he calls FM_n^\sim the Fulton-MacPherson operad, though this operad differs from the standard Fulton-MacPherson operad FM_n .

This operad FM_n seems also better suited for the proof of the formality of the operad of little n -discs (we go back to this subject in §7), which is the purpose of the Kontsevich's construction in [104]. The variant FM_n^\sim is used in Sinha study of knot spaces [155, 156]. The operad FM_n^\sim has the advantage of giving rise to a cosimplicial space which Sinha uses to define models for knot spaces.

4.3.5. The Deligne-Mumford compactification of the moduli spaces of curves.

We now consider the case $n = 2$ of the configuration spaces $F(\mathbb{R}^n, r)$ and of the Fulton-MacPherson operad. In §4.3.1, we consider the action of group of real similarities $\mathbb{R}_{>0} \times \mathbb{R}^n$ on the configuration space $F(\mathbb{R}^n, r)$, but when we deal with configuration of points in the plane $\mathbb{R}^2 = \mathbb{C}$, we can also consider an action of the group of complex similarities $\mathbb{C}^\times \times \mathbb{C}$, consisting of the transformations of the complex plane $\phi : z \mapsto az + b$ such that $a \in \mathbb{C}^\times$, $b \in \mathbb{C}$.

The quotient space occurring in this case $F(\mathbb{C}, r) / \mathbb{C}^\times \times \mathbb{C}$ is identified with the quotient space $F(\mathbb{C}\mathbb{P}^1, r + 1) / PGL_2(\mathbb{C})$ of the configuration space of $r + 1$ points in the projective line $\mathbb{C}\mathbb{P}^1$, which also represents the moduli space of isomorphism classes of genus zero smooth curves with $r + 1$ marked points \mathcal{M}_{0r+1} .

This space \mathcal{M}_{0r+1} has a particular compactification $\overline{\mathcal{M}}_{0r+1}$, the Deligne-Mumford-Knudsen compactification, which represents the moduli space of genus zero stable curves with $r + 1$ marked points, the curves C such that:

- (a) We have at most a finite number of singularities in C , which all consist of double points, and $r + 1$ marked points $a_0, \dots, a_r \in C$ distinct for the singular points. These points all together (the singular points and the marked points) define the special points of our curve.
- (b) Each irreducible component of the curve includes at least three special points.

- (c) The dual graph of the curve, which has the irreducible components as vertices and the local branches passing through special points as half edges (possibly glued on double points), is a tree.

For instance, for the stable curves of $\overline{\mathcal{M}}_{04}$, we get the following forms of dual graphs:

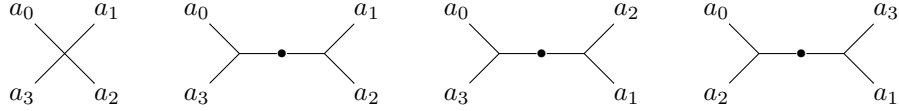

We refer to the work of Deligne and Mumford [46] and Knudsen [100] for a definition of these space $\overline{\mathcal{M}}_{0r+1}$ from a moduli space approach. We refer the work of Keel [97] for a more combinatorial definition of the space $\overline{\mathcal{M}}_{0r+1}$ in terms of iterated blow-up constructions (as in the Fulton-MacPherson compactification process).

The collection $\overline{\mathcal{M}}(r) = \overline{\mathcal{M}}_{0r+1}$ inherits an operad structure, with composition products $\circ_k : \overline{\mathcal{M}}_{0r+1} \times \overline{\mathcal{M}}_{0s+1} \rightarrow \overline{\mathcal{M}}_{0r+s}$ defined at the point set level by the natural gluing operation of curves on marked points. The space $\overline{\mathcal{M}}_{0r+1}$ is also equipped with a stratification, with strata parameterized by the dual graphs of curves, and which reflects the composition structure of the operad $\overline{\mathcal{M}}$. We refer to [71] for the detailed definition of the operad structure and of this correspondence with the stratification of the spaces $\overline{\mathcal{M}}_{0r+1}$.

The articles [97] gives a description of the cohomology ring of the space $\overline{\mathcal{M}}_{0r+1}$. The Fulton-MacPherson compactification of the configuration space $F(\mathbb{C}P^1, r + 1)$ in [62] includes a divisor which is isomorphic to the cartesian product of the space $\overline{\mathcal{M}}_{0r+1}$ with the affine line \mathbb{A}^1 , and can also be used to give a description of this cohomology ring $H^*(\overline{\mathcal{M}}_{0r+1})$.

The homology of the spaces $\overline{\mathcal{M}}_{0r+1}$ also forms a operad in graded modules $H_*(\overline{\mathcal{M}})$, like the homology of the little 2-discs spaces. The structure of this operad is determined in [71], in terms of a presentation by generators and relations. In short, the result asserts that this homology operad $H_*(\overline{\mathcal{M}})$ is identified with an operad *HyCom*, called the hypercommutative operad in [71], which has a symmetric generating operation $\mu_r \in \text{HyCom}(r)$ in each arity $r \geq 2$, and higher associativity relations as generating relations. We also refer to the book [125] for a account of this computation, and the relationship with structures associated to the quantum cohomology of projective algebraic varieties.

4.3.6. *The operad of framed little discs.* We have a connection between the little discs and the Deligne-Mumford-Knudsen operads, which can be made more precise by considering a framed version of the little 2-discs operad of §§4.1.1-4.1.3.

In §4.1.1, we define a little n -disc as an affine embedding $c : \mathbb{D}^n \hookrightarrow \mathbb{D}^n$ of the form $c(t_1, \dots, t_n) = (a_1, \dots, a_n) + r \cdot (t_1, \dots, t_n)$, for a translation term $(a_1, \dots, a_n) \in \mathring{\mathbb{D}}$, and a scaling factor $r > 0$. The framed little n -discs, occurring in the definition of the framed little n -discs operad $f\mathcal{D}_n$, are defined by embeddings $c : \mathbb{D}^n \rightarrow \mathbb{D}^n$ of the form $c(t_1, \dots, t_n) = (a_1, \dots, a_n) + r \cdot q(t_1, \dots, t_n)$, where, with respect to the little discs of §4.1.1, we consider an additional rotation transformation $q \in SO_n$. The space $f\mathcal{D}_n(r)$ precisely consists of collections of embeddings of this form $\underline{c} = (c_1, \dots, c_r)$ with the same intersection condition $i \neq j \Rightarrow \mathring{c}_i \cap \mathring{c}_j = \emptyset$ as in the definition of the ordinary little n -discs operad \mathcal{D}_n . The symmetric, unit, and composition structure of this operad $f\mathcal{D}_n$ are defined by an obvious extension of the

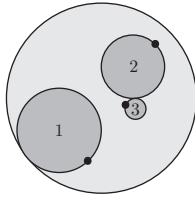

FIGURE 4.6. The representation of an element in the framed little 2-disc operad.

construction of §4.1.3. The framed little discs operad fD_n has a natural unitary extension fD_{n+} satisfying $fD_{n+}(0) = pt$ too.

In the 2-dimensional case, we add a mark to the picture of the little 2-discs in order to represent the angle of the rotation occurring in the definition of the framed little discs (the horizontal axis defining the zero angle). Figure 4.6 for instance gives the picture of a configuration of framed little discs in the space $fD(3)$.

We now focus on the case $n = 2$ of the construction. Let S be the operad such that $S(1) = SO_2 = S^1$ and $S(r) = \emptyset$ for $r \neq 1$. We have an obvious operad morphism $S \rightarrow fD_2$. The moduli space operad $\overline{\mathcal{M}}$ of §4.3.5 is, according to a result of Drumond-Cole [49], identified with the result of a homotopy pushout in the category of topological operads:

$$\begin{array}{ccc}
 S & \longrightarrow & I \\
 \downarrow & & \downarrow \\
 fD_2 & \dashrightarrow & \overline{\mathcal{M}}
 \end{array}$$

This operadic homotopy pushout is an instance of the homotopical algebra construction which we study in §II.1.

The operad $H_*(S)$ has a single generating operation Δ , given by the fundamental class of the sphere in arity one $H_*(S(1)) = H_*(S^1)$, and we have $\Delta \circ_1 \Delta = 0$. The operad $H_*(fD_2)$ is identified with an operadic semi-direct product of the Gerstenhaber operad $Gerst_1$ and of the operad $H_*(S)$. We refer to [70] for a full description of this homology operad $H_*(fD_2)$, which is usually called the Batalin-Vilkovsky operad in the literature. We also refer to [150] for a description of the homology operad $H_*(fD_n)$ in the case $n \geq 2$.

4.4. Appendix: the symmetric monoidal category of graded modules

Let \mathbb{k} be any fixed a ground ring. In §0.1, we define the category of graded modules $gMod$ as the category formed by \mathbb{k} -modules K equipped with a splitting $K = \bigoplus_{n \in \mathbb{Z}} K_n$. A morphism of graded modules is a morphism of \mathbb{k} -modules $f : K \rightarrow L$ such that $f(K_n) \subset L_n$, for all $n \in \mathbb{Z}$. We say that an element $x \in K$ is homogeneous of degree $n \in \mathbb{Z}$, and we write $\deg(x) = n$, when we have $x \in K_n$.

The main purpose of this appendix is to explain the definition of our symmetric monoidal structure on graded modules. By the way, we also check the existence of graded hom-objects $\text{Hom}_{gMod}(-, -) : gMod^{op} \times gMod \rightarrow gMod$ defining an internal hom in this monoidal category $gMod$.

4.4.1. *The symmetric monoidal structure of graded modules.* The tensor product of $K, L \in gMod$ in the category of graded modules is the tensor product of K and L as \mathbb{k} -modules, which we equip with the decomposition $K \otimes L = \bigoplus_{n \in \mathbb{Z}} (K \otimes L)_n$

i

such that $(K \otimes L)_n = \bigoplus_{p+q=n} K_p \otimes L_q$. This construction obviously gives a bifunctor $\otimes : g\mathcal{M}od \times g\mathcal{M}od \rightarrow g\mathcal{M}od$ with the ground ring \mathbb{k} regarded as a graded module concentrated in degree 0 as unit object. We also have an obvious associativity isomorphism $(K \otimes L) \otimes M \simeq K \otimes (L \otimes M)$ inherited from \mathbb{k} -modules.

We get an obvious symmetry isomorphism from the category of \mathbb{k} -modules too, but we shall modify this basic isomorphism in order to implement the signs of dg-algebra in our categorical operations on graded modules. We precisely define our symmetry isomorphism $c : K \otimes L \rightarrow L \otimes K$ by the formula $c(x \otimes y) = (-1)^{pq} y \otimes x$, for any pair of homogeneous elements $x \in K_p$ and $y \in L_q$, where we consider the sign $(-1)^{pq}$ determined by the rules of §0.2. We generally simply add the symbol \pm to mark the occurrence of such a sign in a formula (see §0.2). We take this symmetry isomorphism $c : K \otimes L \rightarrow L \otimes K$ to complete our definition of the symmetric monoidal structure on graded modules.

We immediately see that the tensor product of graded modules satisfies the colimit requirement §0.9(a). We mention in §0.14 that this extra condition is related to the existence of an internal hom in the category of graded modules. We make this internal hom explicit in the next paragraph.

4.4.2. *The internal hom of graded modules.* We basically define the internal hom of graded modules $L, M \in g\mathcal{M}od$ as the graded module $\mathbf{Hom}_{g\mathcal{M}od}(L, M)$ spanned in degree n by the morphisms of \mathbb{k} -modules $f : L \rightarrow M$ such that $f(L_p) \subset L_{p+n}$. Thus, we set $\mathbf{Hom}_{g\mathcal{M}od}(L, M)_n = \prod_p \mathbf{Hom}_{g\mathcal{M}od}(L_p, M_{p+n})$, for each $n \in \mathbb{Z}$. The adjunction relation $\mathbf{Mor}_{g\mathcal{M}od}(K \otimes L, M) \simeq \mathbf{Mor}_{g\mathcal{M}od}(K, \mathbf{Hom}_{g\mathcal{M}od}(L, M))$ easily follows from the adjunction relation of \mathbb{k} -modules. Note that a morphism of graded modules is identified with a homomorphism of degree 0, where according to the conventions of §0.13, we use the term of homomorphism to refer to an element of the graded hom $\mathbf{Hom}_{g\mathcal{M}od}(L, M)$.

In §0.14, we mention that, for general reasons, the internal hom-objects of a closed symmetric monoidal category inherit a composition product, an internal tensor product operation, and evaluation morphisms. In the context of graded modules, the evaluation morphism is identified with the morphism of graded modules $\epsilon : \mathbf{Hom}_{g\mathcal{M}od}(L, M) \otimes L \rightarrow M$ mapping any tensor $f \otimes x$, such that $f \in \mathbf{Hom}_{g\mathcal{M}od}(L, M)$, $x \in L$, to the element $f(x) \in M$ defined by applying the \mathbb{k} -module map $f : L \rightarrow M$ to $x \in L$. Note that $\mathbf{Hom}_{g\mathcal{M}od}(L, M) \otimes L$ refers to the tensor product of graded modules in this construction. The composition product $\circ : \mathbf{Hom}_{g\mathcal{M}od}(L, M) \otimes \mathbf{Hom}_{g\mathcal{M}od}(K, L) \rightarrow \mathbf{Hom}_{g\mathcal{M}od}(K, M)$ is induced by the obvious composition operation on \mathbb{k} -module morphisms. The tensor product operation $\otimes : \mathbf{Hom}_{g\mathcal{M}od}(K, L) \otimes \mathbf{Hom}_{g\mathcal{M}od}(M, N) \rightarrow \mathbf{Hom}_{g\mathcal{M}od}(K \otimes M, L \otimes N)$ maps (homogeneous) homomorphisms $f : K \rightarrow L$ and $g : M \rightarrow N$ to the homomorphism $f \otimes g : K \otimes M \rightarrow L \otimes N$ such that $(f \otimes g)(x \otimes y) = \pm f(x) \otimes g(y)$, for any pair of (homogeneous) elements $x \in K$ and $y \in M$, where the sign \pm is produced by the commutation of f and x .

Braids and the Recognition of E_2 -operads

Recall that an operad P is E_n when we have weak-equivalences of topological operads $P \xleftarrow{\sim} \cdot \xrightarrow{\sim} D_n$ connecting P to the operad of little n -discs D_n . In this situation, we also say that P is weakly-equivalent to D_n . In many problems the issue is to prove that a given operad P is E_n . The usual method is to apply an appropriate recognition criterion building the required weak-equivalences from internal structures of P .

In the previous chapter, we observed that a topological operad P is E_1 if only if each space $P(r)$ has contractible components which form an operad in sets $\pi_0 P$ isomorphic to the operad of associative monoids As . This criterion actually implies that P is weakly-equivalent to the set operad As , viewed as a discrete operad in topological spaces. The weak-equivalence with the little 1-discs operad follows from the observation that the operad D_1 is itself weakly-equivalent to As . Similarly, we observed that a topological operad P is E_∞ if only if each space $P(r)$ is contractible. This criterion actually implies that P is weakly-equivalent to the discrete set operad of commutative monoids Com . The weak-equivalence with D_∞ follows, again, from the observation that D_∞ consists of contractible spaces and is itself weakly-equivalent to Com .

The main objective of this chapter is to explain a similar characterization, due to Z. Fiedorowicz [56], for the class of E_2 -operads.

We start with the observation that each space $D_2(r)$ is an Eilenberg-MacLane space $K(P_r, 1)$, where $P_r = \pi_1 D_2(r)$ denotes the pure braid group on r strands. We then consider the universal covering $\check{D}_2(r)$ of the little 2-discs space $D_2(r)$, which is contractible and comes equipped with a P_r -action so that $\check{D}_2(r)/P_r = D_2(r)$. This action of the pure braid group P_r on the covering space $\check{D}_2(r)$ actually extends to an action of the entire braid group B_r which lifts the action of the symmetric group Σ_r on the little 2-discs space $D_2(r)$. The crux of Fiedorowicz's idea relies on the observation that the collection of spaces $\check{D}_2 = \{\check{D}_2(r)\}_r$ inherits the same structure as an operad, except that have to replace the symmetric group actions of the standard definition §1.1.1 by the just considered braid group actions. We adopt the name of braided operad for this variant of the notion of an operad. We regard the quotient process $\check{D}_2(r)/P_r = D_2(r)$ giving the connection between the little 2-discs space $D_2(r)$ and the associated universal covering space $\check{D}_2(r)$ as an instance of a general symmetrization process, which enables us to retrieve a symmetric operad from any braided operad structure. The recognition theorem of Z. Fiedorowicz precisely asserts that any operad P obtained by symmetrization $P(r) = \check{P}(r)/P_r$ from a contractible braided operad \check{P} is E_2 .

We notably use this recognition method to check that the classifying spaces of a certain operad in groupoids, the operad of colored braids, forms an instance of an E_2 -operad.

In a preliminary section §5.0, we survey basic concepts of braid theory and we recall the definition of the braid groups B_r . In §5.1, we explain the definition of a braided operad and we state Fiedorowicz’s recognition criterion. In §5.2, we give the definition of the operad of colored braids, and we explain our construction of a model of E_2 -operad from the classifying spaces of this operad in groupoids. In §5.3, we explain that the operad of colored braids is also equivalent to an operad in groupoids, naturally associated to the little 2-discs operad, formed by the fundamental groupoids of the little 2-discs spaces. In a concluding section §5.4, we give a brief introduction to more general recognition theorems, aiming to give characterizations of E_n -operads for all $n \geq 1$.

The ideas of §§5.1-5.2 are mostly borrowed from [56]. The preprint [181] provides a generalization of this approach for the recognition of operads built from Eilenberg-MacLane spaces. In §5.3, we outline another approach of Fiedorowicz’s criterion, involving the adjunction between classifying spaces and fundamental groupoids.

5.0. Braid groups

In the previous chapter, we introduced the configuration spaces $F(\mathring{\mathbb{D}}^n, r)$ as a suitable model of the little n -discs spaces $D_n(r)$, which we use to perform cohomology and homology computations. By the way, we observed that, in the case $n = 1$, the configuration spaces $F(\mathring{\mathbb{D}}^1, r)$ have contractible connected components, indexed by the permutations of the sequence $(1, \dots, r)$, just like the little 1-discs spaces $D_1(r)$. Let us begin this chapter with the following preliminary observation about the homotopy of the spaces $F(\mathring{\mathbb{D}}^n, r)$ for $n > 1$:

PROPOSITION 5.0.1. *The spaces $F(\mathring{\mathbb{D}}^n, r)$ are connected for all $n > 1$. If $n > 2$, then we have $\pi_1 F(\mathring{\mathbb{D}}^n, r) = 0$ too. If $n = 2$, then we have in contrast $\pi_* F(\mathring{\mathbb{D}}^2, r) = 0$, for $* \neq 1$.*

PROOF. In the previous chapter, we recalled that the maps $f : F(\mathring{\mathbb{D}}^n, r) \rightarrow F(\mathring{\mathbb{D}}^n, r - 1)$ which forget about the last component of a configuration is a fibration. The idea is to prove the proposition by induction on r , by using the homotopy exact sequence

$$\begin{aligned} \dots &\rightarrow \pi_*(f^{-1}(\underline{b}), \underline{a}) \rightarrow \pi_*(F(\mathring{\mathbb{D}}^n, r), \underline{a}) \xrightarrow{f_*} \pi_*(F(\mathring{\mathbb{D}}^n, r - 1), \underline{b}) \rightarrow \dots \\ \dots &\rightarrow \pi_1(f^{-1}(\underline{b}), \underline{a}) \rightarrow \pi_1(F(\mathring{\mathbb{D}}^n, r), \underline{a}) \xrightarrow{f_*} \pi_1(F(\mathring{\mathbb{D}}^n, r - 1), \underline{b}) \rightarrow \underbrace{\pi_0(f^{-1}(\underline{b}), \underline{a})}_{=*} \end{aligned}$$

associated to these fibrations, where $\underline{a} = (a_1, \dots, a_r)$ is a fixed base point in the configuration space $F(\mathring{\mathbb{D}}^n, r)$, and we set $\underline{b} = (a_1, \dots, a_{r-1}) = f(\underline{a})$. The fiber of the map f at this base point \underline{b} is identified with the punctured space

$$f^{-1}(\underline{b}) = \{(a_1, \dots, a_{r-1}, b) \in \mathring{\mathbb{D}}^n \mid b \neq a_1, \dots, a_{r-1}\} = \mathring{\mathbb{D}}^n \setminus \{a_1, \dots, a_{r-1}\},$$

which is connected as soon as $n > 1$. Hence, we have the identity $\pi_0(f^{-1}(\underline{a}), a_r) = *$ as indicated in our formula.

The connectedness of this space $f^{-1}(\underline{b})$ implies, by induction on r , that the spaces $F(\mathring{\mathbb{D}}^n, r)$ are connected as well, for all $n > 1$. In the case $n > 2$, we have besides $\pi_1(f^{-1}(\underline{b}), \underline{a}) = \pi_1(\mathring{\mathbb{D}}^n \setminus \{a_1, \dots, a_{r-1}\}, a_r) = *$, and by an immediate induction again, we deduce from the degree 1 terms of the homotopy exact sequence

that the spaces $F(\mathring{\mathbb{D}}^n, r)$ are simply connected too. In the case $n = 2$, we have $\pi_*(f^{-1}(\underline{b}), \underline{a}) = \pi_*(\mathring{\mathbb{D}}^2 \setminus \{a_1, \dots, a_{r-1}\}, a_r) = *$ for $* > 1$, and we use the higher terms of the homotopy exact sequence to conclude that $\pi_*(F(\mathring{\mathbb{D}}^2, r), \underline{a})$ vanishes for all $* > 1$. \square

The result of the proposition obviously holds for the little disc spaces $D_n(r)$ since we have a homotopy equivalence $\omega : D_n(r) \xrightarrow{\sim} F(\mathring{\mathbb{D}}^n, r)$ (see Proposition 4.2.2) which induces an isomorphism on homotopy groups. Briefly recall that this homotopy equivalence, which we call the disc center mapping, sends an r -tuple of little n -discs $\underline{c} = (c_1, \dots, c_n)$, defining an element of $D_n(r)$, to the configuration of points defined by the centers $c_i(0, \dots, 0) \in \mathring{\mathbb{D}}^n$ of the discs $c_i : \mathbb{D}^n \rightarrow \mathbb{D}^n$.

The previous proposition implies that the configuration spaces $F(\mathring{\mathbb{D}}^2, r)$, and hence the little 2-discs spaces $D_2(r)$, are Eilenberg-MacLane spaces $K(P_r, 1)$, where we set $P_r = \pi_1(F(\mathring{\mathbb{D}}^2, r), *)$. Recall that this group P_r is the pure braid group on r strands. The Artin braid group B_r , which we also consider in our study of E_2 -operads, sits in a short exact sequence $1 \rightarrow P_r \rightarrow B_r \rightarrow \Sigma_r \rightarrow 1$. The purpose of this preliminary section is to recall the classical interpretation of these groups, in terms of isotopy classes of braids on r strands, and the geometric representation arising from this interpretation. The identity between little 2-discs spaces $D_2(r)$ and the Eilenberg-MacLane spaces $K(P_r, 1)$ is used in the next sections.

To begin with, we explain the definition of the Artin braid group B_r as the fundamental group of a space.

5.0.2. *Braid groups.* Recall that the space $F(\mathring{\mathbb{D}}^2, r)$ is equipped with an action of the symmetric group Σ_r , given by the standard formula

$$w_*(a_1, \dots, a_r) = (a_{w^{-1}(1)}, \dots, a_{w^{-1}(r)}),$$

for all $(a_1, \dots, a_r) \in F(\mathring{\mathbb{D}}^2, r)$, and for any permutation $w \in \Sigma_r$ (see Proposition 4.2.3). The braid group on r strands B_r is precisely defined as the fundamental group of the quotient of the configuration space $F(\mathring{\mathbb{D}}^2, r)$ under this action:

$$B_r = \pi_1(F(\mathring{\mathbb{D}}^2, r)/\Sigma_r, *).$$

The quotient map $q : F(\mathring{\mathbb{D}}^2, r) \rightarrow F(\mathring{\mathbb{D}}^2, r)/\Sigma_r$ induces a morphism $q_* : P_r \rightarrow B_r$.

We easily check that:

LEMMA 5.0.3. *The symmetric group Σ_r acts freely and properly on $F(\mathring{\mathbb{D}}^2, r)$ so that the quotient map $q : F(\mathring{\mathbb{D}}^2, r) \rightarrow F(\mathring{\mathbb{D}}^2, r)/\Sigma_r$ is a covering map.* \square

Then we apply standard results of covering theory to obtain:

PROPOSITION 5.0.4. *The morphism $q_* : P_r \rightarrow B_r$ fits in an exact sequence of groups $1 \rightarrow P_r \xrightarrow{q_*} B_r \xrightarrow{p_*} \Sigma_r \rightarrow 1$, where $p_* : B_r \rightarrow \Sigma_r$ is deduced from the action of $B_r = \pi_1(F(\mathring{\mathbb{D}}^2, r)/\Sigma_r, *)$ on the fiber of the covering $q : F(\mathring{\mathbb{D}}^2, r) \rightarrow F(\mathring{\mathbb{D}}^2, r)/\Sigma_r$ at any base point $* \in F(\mathring{\mathbb{D}}^2, r)/\Sigma_r$.* \square

5.0.5. *Braids and braid diagrams.* The braids, giving the name of braid groups, come in a representation of the paths in the configuration space $F(M, r)$ associated to any manifold M . We review this representation of a braid before recalling the classical presentation of the braid groups by generators and relations. For our purpose, we focus on the case $M = \mathring{\mathbb{D}}^2$, and our braids are defined in the cylinder $\mathring{\mathbb{D}}^2 \times [0, 1]$. In our survey, we refer to works dealing with braids in the

euclidean plane $M = \mathbb{R}^2$, rather than in the open disc $M = \mathring{\mathbb{D}}^2$. We just use that the homeomorphism between the euclidean plane and the open disc gives an equivalence between the notions of braids associated to these spaces in order to get the correspondence between our presentation and the set-up of these references.

We precisely define a braid with r strands in $\mathring{\mathbb{D}}^2$ as a collection of r disjoint arcs $\alpha_i : [0, 1] \rightarrow \mathring{\mathbb{D}}^2 \times [0, 1]$, $i = 1, \dots, r$, of the form

$$\alpha_i(t) = (x_i(t), y_i(t), t), \quad t \in [0, 1],$$

and whose origin $\alpha_i(0) = (x_i(0), y_i(0), 0)$ and end-point $\alpha_i(1) = (x_i(1), y_i(1), 1)$ lie in a set of fixed contact points $\{(x_k^0, 0, t^0) | k = 1, \dots, r\}$ on the axis $y = 0$ of the boundary discs of our cylinder $\mathring{\mathbb{D}}^2 \times \{t^0\}$, $t^0 = 0, 1$ (see [9]). We can take the set of equidistant points

$$(x_k^0, 0, 0), (x_k^0, 0, 1), \quad \text{with } x_k^0 = -1 + (2k - 1)/(r + 1), \quad k = 1, \dots, r,$$

as contact points for the moment.

The requirement that the arcs α_i are disjoint amounts to the relation

$$(x_i(t), y_i(t)) \neq (x_j(t), y_j(t))$$

for all $i \neq j$ and every $t \in [0, 1]$. In the case $t^0 = 0, 1$, this assumption implies that the r -tuple $(\alpha_1(t^0), \dots, \alpha_r(t^0)) = ((x_1(t^0), 0, t^0), \dots, (x_r(t^0), 0, t^0))$ forms a permutation of $((x_1^0, 0, t^0), \dots, (x_r^0, 0, t^0))$. The mapping $s : k \mapsto s(k)$ such that

$$x_i(0) = x_k^0, \quad x_i(1) = x_{s(k)}^0, \quad \text{for } i = 1, \dots, r,$$

defines a permutation $s \in \Sigma_r$, naturally associated to our braid α , and usually referred to as the underlying permutation of the braid α .

The set of pure braids consists of the braids which have the identity as underlying permutation.

The arcs α_i define the strands of the braid. For the moment, we take the convention that the collection of strands α_i , $i = 1, \dots, r$, defining a braid α is equipped with the indexing such that $\alpha_i(0) = (x_i^0, 0, 0)$, for $i = 1, \dots, r$. We then have $(\alpha_1(1), \dots, \alpha_r(1)) = ((x_{s(1)}^0, 0, 1), \dots, (x_{s(r)}^0, 0, 1))$, where $s \in \Sigma_r$ is the permutation associated to our braid. We adopt another convention in §5.2 where we consider braids equipped with additional structures for which this ordering is not natural.

We use a projection onto the plane (x, t) to get a convenient representation of our braids. We give an example of this representation in Figure 5.1, for a braid on 4 strands with

$$s = \begin{pmatrix} 1 & 2 & 3 & 4 \\ 4 & 2 & 1 & 3 \end{pmatrix}$$

as underlying permutation. The projection picture works for braids such that the intersection between the projected arcs $(x_i(t), t)$ reduce to isolated points, and so that each intersection $(x_i(t), t) = (x_j(t), t)$ involves no more than two arcs $(x_i(t), t)$, $(x_j(t), t)$. In this context, the usual convention is to insert a gap at each intersection point $(x_i(t), t) = (x_j(t), t)$, as in the example of Figure 5.1, in order to mark the strand going under the other with respect to the y -coordinate. Such a figure is called a braid diagram.

In the next paragraph, we recall the definition of the isotopy relation between braids. The notion of isotopy can be formalized in terms of braid diagrams, and one can prove that braid diagrams are enough to give a faithful picture of braids

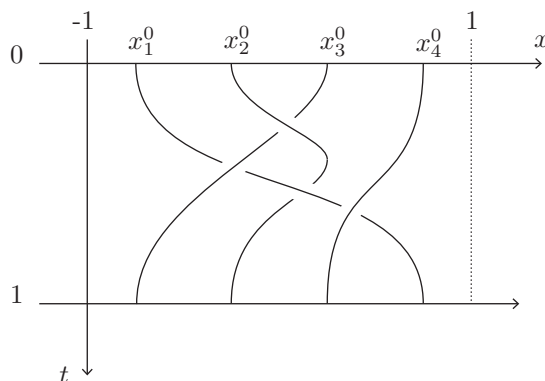

FIGURE 5.1. An instance of braid diagram. In the next pictures, we generally do not specify the abscissa x_i^0 of the contact points. We just mark the index of some contact points when necessary.

up to isotopy. This observation is originally due to E. Artin, and we refer to his article [9], or to the subsequent textbook [96] by C. Kassel and V. Turaev, for more explanations about the relationship between braids and braid diagrams. In what follows, we just use braid diagrams informally, in order to illustrate our constructions.

5.0.6. *Braid isotopies.* By definition, an isotopy from a braid α to another one β is a continuous family of braids h_s such that $h_0 = \alpha$ and $h_1 = \beta$. Two braids are isotopic if we have an isotopy between them, and in this case we write $\alpha \sim \beta$. The isotopy relation is clearly an equivalence relation on the set of braids. Figure 5.2 gives simple instances of braid isotopies and fundamental examples of non-isotopic braids.

Let us regard a braid as a single map $\alpha(t) = (\alpha_1(t), \dots, \alpha_r(t))$ rather than as a collection. The assumption that the underlying braids of an isotopy h_s form a continuous family amounts to the requirement that the two parameter map $h : (s, t) \mapsto h_s(t)$ is continuous on $[0, 1] \times [0, 1]$. By continuity, the requirement that $h_s(1)$ belongs to the discrete space $\{((x_{w(1)}^0, 0, 1), \dots, (x_{w(k)}^0, 0, 1)) \mid w \in \Sigma_r\}$ implies that the map $s \mapsto h_s(1)$, given by the endpoints of the isotopy, is constant. Hence, we see that isotopic braids have the same underlying permutation.

By a standard abuse of language, we generally use the word braid to refer to an isotopy class of braids unless the distinction is made necessary by the context.

5.0.7. *Relationship with the fundamental groups.* We immediately see that a pure braid on r -strands $\alpha_i(t) = (x_i(t), y_i(t), t)$ is equivalent to a based loop $\gamma(t) = ((x_1(t), y_1(t)), \dots, (x_r(t), y_r(t)))$ in the configuration space $F(\mathbb{D}^2, r)$, where we take the configuration of our contact points on the line $\underline{a}^0 = ((x_1^0, 0), \dots, (x_r^0, 0))$ as base point. Similarly, an isotopy of pure braids is equivalent to a homotopy of based loops in $F(\mathbb{D}^2, r)$. Thus, the pure braid group P_r , which we define as the fundamental group of the space $F(\mathbb{D}^2, r)$, is identified with the set of isotopy classes of pure braids.

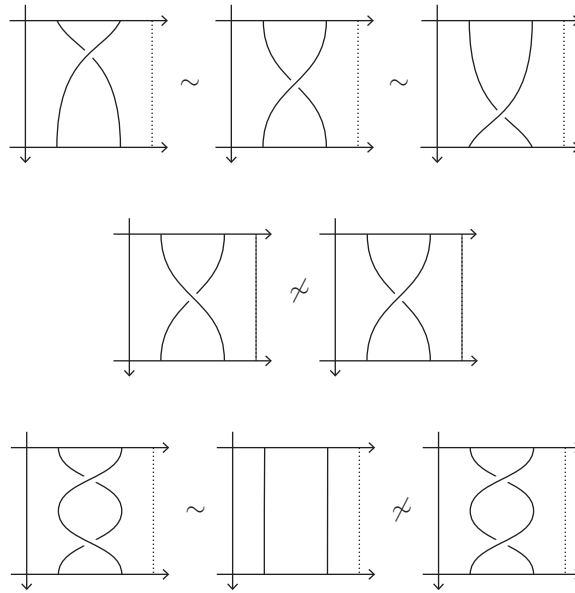

FIGURE 5.2. Basic examples of isotopic and non-isotopic braids

Let $\underline{b}^0 = q(\underline{a}^0)$ be the image of the element $\underline{a}^0 = ((x_1^0, 0), \dots, (x_r^0, 0))$ in the quotient space $F(\hat{\mathbb{D}}^2, r)/\Sigma_r$. The fiber of this point \underline{b}^0 under the covering map $q : F(\hat{\mathbb{D}}^2, r) \rightarrow F(\mathbb{D}^2, r)/\Sigma_r$ is $q^{-1}(\underline{b}^0) = \{((x_{w(1)}^0, 0), \dots, (x_{w(r)}^0, 0)), w \in \Sigma_r\}$. The set of all braids on r strands is identified with the set of paths connecting \underline{a}^0 to another point $w\underline{a}^0 = ((x_{w(1)}^0, 0), \dots, (x_{w(r)}^0, 0))$ in this fiber. Braid isotopies are also equivalent to path homotopies. By standard results of covering theory, any loop γ based at \underline{b}^0 in the quotient space $F(\mathbb{D}^2, r)/\Sigma_r$ lifts to a path of this form $\tilde{\gamma}$, with $\tilde{\gamma}(0) = \underline{a}^0$ and $\tilde{\gamma}(1) = w\underline{a}^0$ for some $w \in \Sigma_r$. Moreover, such a lifting is unique once we fix the starting point $\tilde{\gamma}(0) = \underline{a}^0$ and any homotopy of based loops lifts to a path homotopy. Hence, the full braid group B_r , which we define as the fundamental group of the quotient space $F(\hat{\mathbb{D}}^2, r)/\Sigma_r$, is identified with the set of isotopy classes of all braids.

In both cases P_r and B_r , the group multiplication can readily be identified with a natural concatenation operation on braids, of which the Figure 5.3 gives an example. The unit element with respect to this group multiplication is given by the identity braid, represented in Figure 5.4. (In what follows, we also use the notation id to refer to this braid.) Note that we perform compositions downwards, in the increasing direction of the t coordinates, in contrast with conventions adopted by other authors. Our choice is more natural when we regard braids as morphisms oriented from a source to a target object, and we heavily use this interpretation next.

In Proposition 5.0.3, we refer to a general result of covering theory in order to define the morphism $p_* : B_r \rightarrow \Sigma_r$. By going back to the proof of this result,

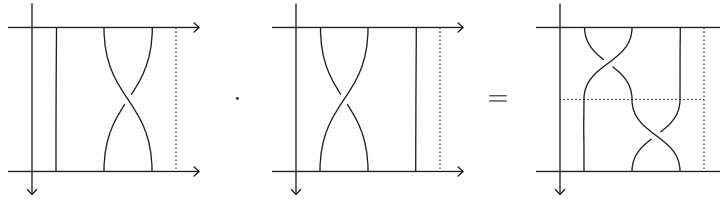

FIGURE 5.3. The concatenation of braids

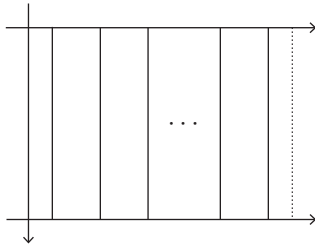

FIGURE 5.4. The identity braid

we immediately see that the morphism $p_* : B_r \rightarrow \Sigma_r$ is identified with the map sending the isotopy class of a braid α to its underlying permutation s . The natural embedding of the subset of pure braids into the set of all braids gives the morphism $q_* : P_r \rightarrow B_r$. Thus we have a full interpretation of the exact sequence of groups $1 \rightarrow P_r \rightarrow B_r \rightarrow \Sigma_r \rightarrow 1$ in terms of isotopy classes of braids.

5.0.8. *Generating elements.* For $i = 1, \dots, r-1$, we consider the element $\tau_i \in B_r$ represented by the diagram of Figure 5.5

The mapping $q_* : B_r \rightarrow \Sigma_r$ assigns the elementary transposition $t_i = (i \ i+1) \in \Sigma_r$ to this braid $\tau_i \in B_r$. In §0.10, we recall that the symmetric group has a simple presentation by generators and relations involving these transpositions t_i , $i = 1, \dots, r-1$, as generating elements. For the braid group, we have the following classical result:

THEOREM 5.0.9 (see [8]). *The braid group B_r is generated by the elements τ_i , $i = 1, \dots, r-1$, together with the commutation relations*

$$\tau_i \tau_j = \tau_j \tau_i, \quad \text{for } i, j = 1, \dots, r-1 \text{ such that } |i-j| \geq 2,$$

and the braid relations

$$\tau_i \tau_{i+1} \tau_i = \tau_{i+1} \tau_i \tau_{i+1}, \quad \text{for } i = 1, \dots, r-2,$$

as generating relations (see also the representation of these relations in Figure 5.6). \square

In other words, the braid group B_r is given by the same presentation as the symmetric group Σ_r , except that we drop the involution relation $t_i^2 = 1$ associated to transpositions. The idea of this result goes back to the work of E. Artin [8] cited in reference. We refer to [24], [58], and [96] for various proofs of the theorem.

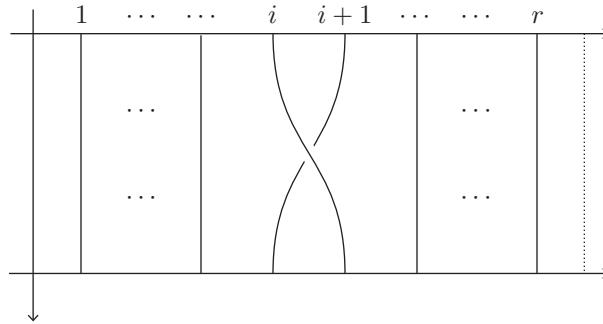

FIGURE 5.5. The generating braids

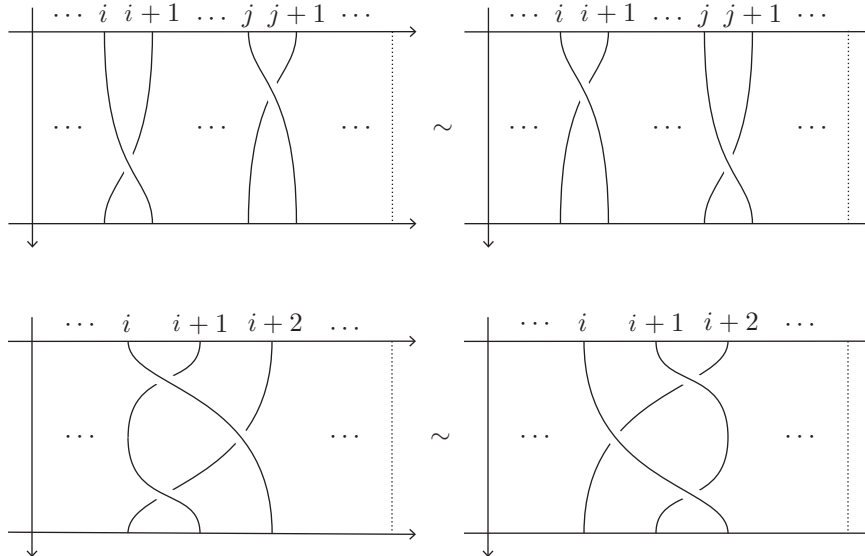

FIGURE 5.6. The commutation and braid relations in braid groups.

The inverse of a generator τ_i in the braid group can actually be obtained by switching the disposition of the strands in the representation of Figure 5.5 (the $i + 1$ th strand comes in the foreground and i th strand goes in the background). The case $r = 2$, where the braid is reduced to these overlapping strands, has already been represented in Figure 5.2, to give an example of non-isotopic braids.

5.0.10. *Change of contact points.* In the definition of §5.0.5, we assume that the origin points of a braid belong to the subset $\{(x_k^0, 0, 0) | k = 1, \dots, r\}$, where $x_k^0 = -1 + (2k - 1)/(r + 1)$, and the end points belong to the subset $\{(x_k^0, 0, 1) | k = 1, \dots, r\}$. Equivalently, our braids correspond to paths in the configuration space

$F(\mathring{\mathbb{D}}^2, r)$ starting at the element $((x_1^0, 0), \dots, (x_r^0, 0))$ and ending at a permutation $((x_{w(1)}^0, 0), \dots, (x_{w(r)}^0, 0))$ of this base point $((x_1^0, 0), \dots, (x_r^0, 0))$.

In principle, the fundamental groups arising from different choices of base points in a connected space are isomorphic. In our case, we obtain the same result if we replace our collection of contact points $\{(x_k^0, 0) | k = 1, \dots, r\} \times \{0, 1\}$, in the definition of the braid group by an arbitrary one $\{(a_k, b_k) | k = 1, \dots, r\} \times \{0, 1\}$. But the definition of an isomorphism comparing the groups associated to these choices involves the choice of a path $\gamma(t) = (\gamma_1(t), \dots, \gamma_r(t))$ going from one configuration $\gamma(0) = ((x_1^0, 0), \dots, (x_r^0, 0))$ to the other one $\gamma(1) = ((a_1, b_1), \dots, (a_r, b_r))$ in the space $F(\mathring{\mathbb{D}}^2, r)$. In the braid picture, we consider a concatenation of the strands of our braids with the arcs of the path γ . This isomorphism clearly depends on the homotopy class of the path γ , and hence, is not canonical in general.

In the sequel, we implicitly use changes of base points, but we also need a strict control of the isomorphism involved in the operation. For this aim, we restrict ourselves to base configurations of the form $((a_1, 0), \dots, (a_r, 0))$, where all points lie on the line $y = 0$, and for which we assume $a_1 < \dots < a_r$. Equivalently, we only consider base configurations arising from a configuration (a_1, \dots, a_r) in the equatorial 1-disc $\mathring{\mathbb{D}}^1 \subset \mathring{\mathbb{D}}^2$, and belonging to the connected component associated to the permutation $(1, \dots, r)$ in the configuration space $F(\mathring{\mathbb{D}}^1, r)$. Since $F(\mathring{\mathbb{D}}^1, r)$ has contractible connected components, all paths $\gamma(t) = (\gamma_1(t), \dots, \gamma_r(t))$ going from one such configuration to another one within this space are homotopic and hence, induce the same isomorphism at the fundamental group level. Thus, all choices of contact points on the the line $y = 0$ yields the same braid group up to a canonical and well determined isomorphism.

5.0.11. *Degenerate cases.* We should note that the definition of the braid group B_r makes sense for $r = 0$. We then deal with a degenerate situation of braid with an empty set of strands. We therefore have $B_0 = *$ for formal reasons.

The braid group B_1 is also trivial (like the symmetric group Σ_1), with the isotopy class of a one-strand vertical braid as unique element.

5.1. Braided operads and E_2 -operads

Let $\check{D}_2(r)$ be the universal coverings of the spaces of little 2-discs $D_2(r)$. The main purpose of this section is to prove, after [56], that the collection of spaces $\check{D}_2(r)$ inherits a braided variant of the structure of an operad. The main application of this construction, as we explained in the chapter introduction, is a simple characterization of E_2 -operads from contractible braided operads. We conclude our account with the proof of this recognition theorem.

In a preliminary step, we give the general definition of the notion of braided operad. We follow the same plan as in the definition of a symmetric operad (§1.1.1). We essentially replace the symmetric group actions considered in this definition by braid group actions.

5.1.1. *Braided operads.* Explicitly, a braided operad P in a base category \mathcal{M} consists of a sequence of objects $P(r) \in \mathcal{M}$, $r \in \mathbb{N}$, where $P(r)$ is now equipped with an action of the braid group B_r , together with

- (a) a unit morphism $\eta : \mathbb{1} \rightarrow P(1)$
- (b) and composition products $\mu : P(r) \otimes P(n_1) \otimes \dots \otimes P(n_r) \rightarrow P(n_1 + \dots + n_r)$, defined for every $r \geq 0$, and all $n_1, \dots, n_r \geq 0$,

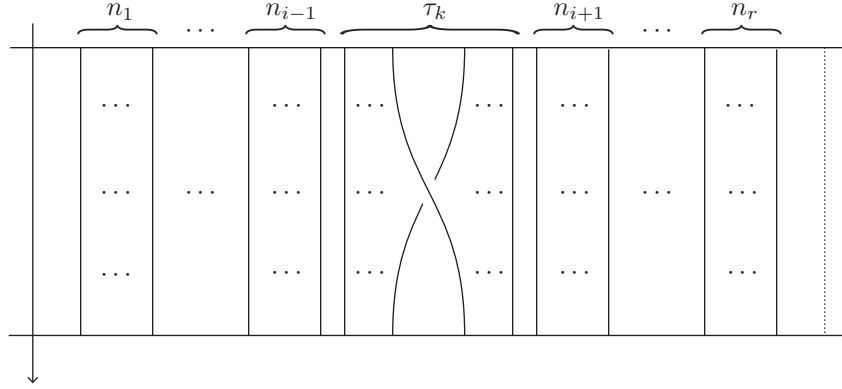

FIGURE 5.7. The direct sum $id \oplus \cdots \oplus \tau_k \oplus \cdots \oplus id$ in the braid group.

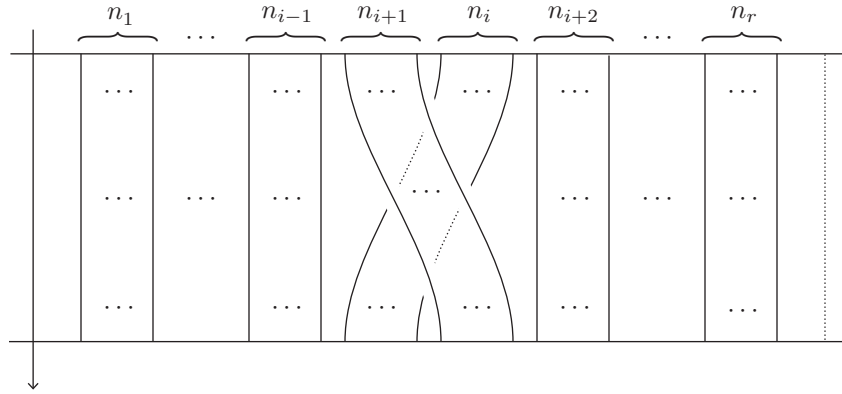

FIGURE 5.8. The block braid $(\tau_i)_*(n_1, \dots, n_r)$

so that natural equivariance, unit and associativity relations, modeled on the same commutative diagram as in the symmetric operad case (Figure 1.1-1.3), hold. We just have to consider braid group elements $\alpha \in B_r$ (respectively, $\beta_1 \in B_{n_1}, \dots, \beta_r \in B_{n_r}$) instead of permutations $s \in \Sigma_r$ (respectively, $t_1 \in \Sigma_{n_1}, \dots, t_r \in \Sigma_{n_r}$) in equivariance relations and an extension to the braid groups of the construction of block permutations and of the direct sum of permutations. We address these constructions in the following proposition:

PROPOSITION 5.1.2. *Let $r \in \mathbb{N}$. Let $n_1, \dots, n_r \in \mathbb{N}$.*

- (a) *The direct sum of permutations, regarded as a mapping $\Sigma_{n_1} \times \cdots \times \Sigma_{n_r} \rightarrow \Sigma_{n_1 + \cdots + n_r}$, has a unique lifting to braid groups*

$$B_{n_1} \times \cdots \times B_{n_r} \rightarrow B_{n_1 + \cdots + n_r},$$

given by the picture of Figure 5.7 for direct sums $id \oplus \cdots \oplus \tau_k \oplus \cdots \oplus id$ involving a single generating element $\tau_k \in B_{n_i}$, and so that we have the

following multiplication relation

$$(\alpha_1 \cdot \beta_1 \oplus \cdots \oplus \alpha_r \cdot \beta_r) = (\alpha_1 \oplus \cdots \oplus \alpha_r) \cdot (\beta_1 \oplus \cdots \oplus \beta_r),$$

for all $(\alpha_1, \dots, \alpha_r), (\beta_1, \dots, \beta_r) \in B_{n_1} \times \cdots \times B_{n_r}$.

- (b) The block permutation construction, regarded as a mapping $\Sigma_r \rightarrow \Sigma_{n_1+\dots+n_r}$, has a unique lifting to braid groups

$$B_r \rightarrow B_{n_1+\dots+n_r},$$

given by the picture of Figure 5.8 for the generating elements $\tau_i \in B_r$, and so that we have the following multiplication relation

$$(\alpha \cdot \beta)_*(n_1, \dots, n_r) = \alpha_*(n_1, \dots, n_r) \cdot \beta_*(n_{s(1)}, \dots, n_{s(r)}),$$

for all $\alpha, \beta \in B_r$, and where s denotes the underlying permutation of the braid α .

- (c) In addition, we have the commutation relation

$$\beta_1 \oplus \cdots \oplus \beta_r \cdot \alpha_*(n_1, \dots, n_r) = \alpha_*(n_1, \dots, n_r) \cdot \beta_{s(1)} \oplus \cdots \oplus \beta_{s(r)}$$

for all $\alpha \in B_r$, every $(\beta_1, \dots, \beta_r) \in B_{n_1} \times \cdots \times B_{n_r}$, and where s denotes the underlying permutation of the braid α again.

PROOF. The multiplication relations imply that these operations on braids are uniquely determined by fixing the image of generating elements. In each case, we simply have to check that our mapping preserves generating relations in order to prove the coherence of our definition.

In (a), we have to deal with the internal generating relations of braid groups, within each factor B_{n_i} , and with the commutation relation

$$\begin{aligned} (id \oplus \cdots \oplus \tau_k \oplus \cdots \oplus id) \cdot (id \oplus \cdots \oplus \tau_l \oplus \cdots \oplus id) \\ = (id \oplus \cdots \oplus \tau_l \oplus \cdots \oplus id) \cdot (id \oplus \cdots \oplus \tau_k \oplus \cdots \oplus id) \end{aligned}$$

when we take generating elements in disjoint factors B_{n_i} and B_{n_j} , $i \neq j$, of the cartesian product $B_{n_1} \times \cdots \times B_{n_r}$. Our mapping visibly preserves all these identities.

The case of construction (b) is addressed by a similar straightforward inspection.

The multiplication relations also imply that we are reduced to check the identity of assertion (c) in the case where one element among α and β_1, \dots, β_r is a generating braid τ_k , and all the others are identities. The validity of the relation in this generating case is still immediate, and this verification completes the proof of our proposition. \square

The braids of Figure 5.7 and Figure 5.8 can also be defined purely algebraically, in terms of the generating elements of the braid group $B_{n_1+\dots+n_r}$. Let $k_i = n_1 + \cdots + n_{i-1}$, $i = 1, \dots, r$. In the case of Figure 5.7, we have:

$$id \oplus \cdots \oplus \tau_k \oplus \cdots \oplus id = \tau_{k_i+k},$$

for all $\tau_k \in B_{n_i}$. In the case of Figure 5.8, we obtain:

$$\begin{aligned} (\tau_k)_*(n_1, \dots, n_r) = \\ (\tau_{k_i+n_i} \cdot \tau_{k_i+n_i-1} \cdots \tau_{k_i+1}) \cdot (\tau_{k_i+n_i+1} \cdot \tau_{k_i+n_i} \cdots \tau_{k_i+2}) \cdots \\ \cdots (\tau_{k_i+n_i+n_{i+1}} \cdot \tau_{k_i+n_i+n_{i+1}-1} \cdots \tau_{k_i+n_{i+1}}). \end{aligned}$$

The definition of the permutation operad in Proposition 1.1.9 has the following braided analogue:

PROPOSITION 5.1.3. *The collection of braid groups B_n , $n \in \mathbb{N}$, forms a braided operad in sets so that:*

- (a) *the action of the braid group on each B_n is given by left translations;*
- (b) *the element of $B_1 = \{id\}$ gives the operadic unit,*
- (c) *and the composition product $\mu : B_r \times (B_{n_1} \times \cdots \times B_{n_r}) \rightarrow B_{n_1 + \cdots + n_r}$ maps a collection $\alpha \in B_r$, $(\beta_1, \dots, \beta_r) \in B_{n_1} \times \cdots \times B_{n_r}$, to the product element*

$$\alpha(\beta_1, \dots, \beta_r) = \beta_1 \oplus \cdots \oplus \beta_r \cdot \alpha_*(n_1, \dots, n_r)$$

in $B_{n_1 + \cdots + n_r}$.

PROOF. This statement easily follows from the relations of Proposition 5.1.2. \square

By convention, we assume that the operad defined in this proposition includes the braid group $B_0 = pt$ as arity 0 component (as in the case of the permutation operad).

The result of §3.1, the equivalence between the plain definition of an operad and the definition in terms of partial composition operations has an obvious extension to braided operads. In the sequel, we use this definition, in terms of partial composites, rather than the plain definition of §5.1.3.

Let $\alpha \in B_m$, $\beta \in B_n$. To illustrate the definition, we give an instance of operadic composition of braids $\alpha \circ_k \beta = \alpha(id, \dots, \beta, \dots, id) \in B_{m+n-1}$ in Figure 5.9. Intuitively, the operadic composite $\alpha \circ_k \beta$ is obtained by inserting the braid β on the k th strand of the braid α . To ease the understanding of our picture, we have marked the array in which the braid β is inserted.

In subsequent constructions, we will use that the strands defining the composite $\alpha \circ_k \beta$ in this process are canonically in bijection with the strands of the braid α , minus the k th one α_k , plus the strands of the braid β .

5.1.4. *Unitary braided operads and restriction operations.* The notion of a non-unitary and of a unitary operad have obvious analogues in the braided setting, and similarly as regards the notion of unitary extension of non-unitary operads. Furthermore, any unitary braided operad P_+ inherits restriction morphisms $u^* : P_+(n) \rightarrow P_+(m)$ associated to all increasing injections $u : \{1 < \cdots < m\} \rightarrow \{1 < \cdots < n\}$, and defined like the restriction morphisms of symmetric operads in §3.2.

The collection of braid groups B_r , $r \in \mathbb{N}$, forms an instance of a unitary braided operad since we have $B_0 = *$. The image of a braid $\alpha \in B_n$ under a restriction operation $u^* : B_n \rightarrow B_m$ is obtained by removing the strands α_k whose index k does not lie in the image of the map $u : \{1 < \cdots < m\} \rightarrow \{1 < \cdots < n\}$. Figure 5.10 gives an instance of application of this restriction process for the injection $u : \{1 < 2\} \rightarrow \{1 < 2 < 3 < 4\}$ such that $u(1) = 2$ and $u(2) = 4$.

The components of a symmetric operad naturally inherit an action of braid groups (by restriction through the canonical morphism $p_* : B_r \rightarrow \Sigma_r$) so that any symmetric operad naturally forms a braided operad. The next proposition gives a functor in the converse direction:

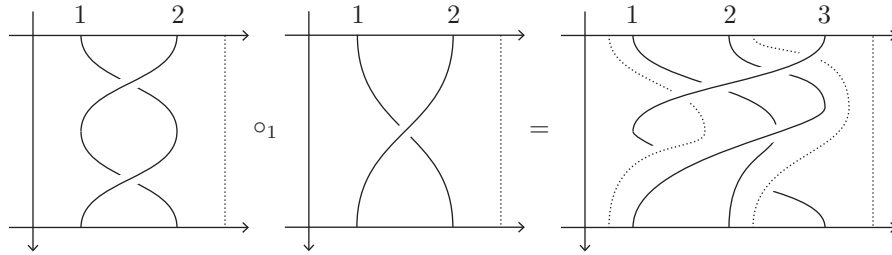

FIGURE 5.9. An operadic composition of braids

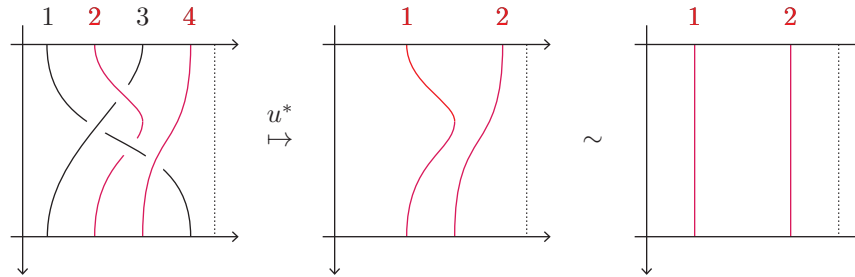

FIGURE 5.10. An instance of restriction operation in the braid operad

PROPOSITION 5.1.5.

- (a) Let P be any braided operad. Let $\mathbf{Sym} P(r) = P(r)/P_r$. The collection of these objects $\mathbf{Sym} P(r)$ inherits a symmetric structure and an operadic composition structure from the braided operad P . Hence the collection of quotient objects $\mathbf{Sym} P(r) = P(r)/P_r$ forms a symmetric operad $\mathbf{Sym} P$ naturally associated to P .
- (b) The mapping $\mathbf{Sym} : P \mapsto \mathbf{Sym} P$ provides a left adjoint of the obvious restriction functor from symmetric operads to braided operads (the functor defined by the componentwise restriction of group actions). The collection of quotient morphisms $P(r) \rightarrow P(r)/P_r$ forms a morphism of braided operads $P \rightarrow \mathbf{Sym} P$ which represents the augmentation of this adjunction.
- (c) In the case of the braid operad $B(r) = B_r$, we have $\mathbf{Sym} B(r) = B_r/P_r = \Sigma_r$ and the symmetric operad $\mathbf{Sym} B$ is identified with the permutation operad, as defined in Proposition 1.1.9.
- (d) The mapping $\mathbf{Sym} : P \mapsto \mathbf{Sym} P$ preserves unitary extensions. To be explicit, for any unitary braided operad P_+ , we have an obvious identity $\mathbf{Sym}(P_+) = \mathbf{Sym}(P)_+$ in the category of symmetric operads.

PROOF. Since $\Sigma_r = B_r/P_r$, we immediately obtain that the action of B_r on $P(r)$ induces an action of the symmetric group Σ_r on the quotient object $P(r)/P_r$.

The operadic unit of P obviously defines a unit morphism $\mathbb{1} \xrightarrow{\eta} \mathbf{Sym} P(1)$ at the level of the collection $\mathbf{Sym} P$ since $\mathbf{Sym} P(1) = P(1)/P_1 = P(1)$. Recall that the direct sums $\beta_1 \oplus \cdots \oplus \beta_r$ as well as the block braid construction $\alpha_*(n_1, \dots, n_r)$ of

Proposition 5.1.2 lift the corresponding constructions on permutations. If β_1, \dots, β_r are pure braids, then so is the direct sum $\beta_1 \oplus \dots \oplus \beta_r$ because we have the identity $id_{n_1} \oplus \dots \oplus id_{n_r} = id_{n_1 + \dots + n_r}$ at the level of permutations, and similarly in the case of the block braid $\alpha_*(n_1, \dots, n_r)$. Thus, the permutations $\beta_1 \oplus \dots \oplus \beta_r$ and $\alpha_*(n_1, \dots, n_r)$ occurring in the equivariance relations of braided operads are pure whenever α and β_1, \dots, β_r are pure braids. From this observation, we immediately deduce that the composition products of the operad P induce composition products on the collection of quotient objects $\text{Sym } P(r) = P(r)/P_r$ so that we have a commutative diagram

$$\begin{array}{ccc}
 P(r) \otimes P(n_1) \otimes \dots \otimes P(n_r) & \xrightarrow{\mu} & P(n_1 + \dots + n_r) \\
 \downarrow & & \downarrow \\
 P(r)/P_r \otimes P(n_1)/P_{n_1} \otimes \dots \otimes P(n_r)/P_{n_r} & \xrightarrow[\exists \mu]{} & P(n_1 + \dots + n_r)/P_{n_1 + \dots + n_r}
 \end{array}$$

for every $r \geq 0$ and all $n_1, \dots, n_r \geq 0$. Furthermore, the equivariance, unit and associativity relations of Figure 1.1-1.3 remain obviously satisfied in the quotient $\text{Sym } P$. This verification completes the construction of the symmetric operad $\text{Sym } P$ associated to P . The assertion about the adjunction relation follows from a straightforward inspection of our construction.

The identity between the symmetrization of the braided operad and the permutation operad follows from the observation that the composition operation on braids $\alpha(\beta_1, \dots, \beta_r) = \beta_1 \oplus \dots \oplus \beta_r \cdot \alpha_*(n_1, \dots, n_r)$ lifts a corresponding operation on permutations.

The last assertion of the proposition is immediate. □

Our main objective is to prove that the topological operad of little 2-discs is the symmetrization of a contractible braided operad in topological spaces. For this purpose, we consider the universal coverings $\check{D}_2(r)$ of the little 2-discs spaces $D_2(r)$. The result reads:

THEOREM 5.1.6 (Z. Fiedorowicz [56]). *The universal coverings $\check{D}_2(r)$ of the little 2-disc spaces $D_2(r)$ form a braided operad in topological spaces \check{D}_2 with the operad of little 2-discs D_2 as associated symmetric operad.*

The construction of this operad structure works for the unitary extension of the operad of little 2-discs D_{2+} as well, and gives in this case a unitary extension \check{D}_{2+} of the non-unitary operad \check{D}_2 .

We address the proof of this theorem in a series of constructions and lemmas. We focus on the definition of the non-unitary operad structure on the collection of covering spaces $\check{D}_2(r)$, $r > 0$. The extension of our constructions to the unitary setting is straightforward.

Recall that the definition of a universal covering depends on the choice of a base point in the base space. To be precise, the universal coverings associated to different base points are isomorphic, but the isomorphisms connecting them is not canonical, and we need a rigid construction in order to check that the operad relations hold at the level of universal covers. We use a specific choice of base points in the little 2-disc spaces in order to work out this issue. We devote the next paragraph to this point.

5.1.7. *The choice of base points.* Recall that the operad of little 1-discs embeds into the little 2-discs operad by a topological inclusion $D_1 \hookrightarrow D_2$. In Proposition 4.1.6, we prove that each space $D_1(r)$ has contractible connected components $D_1(r)_w$ indexed by permutations $w \in \Sigma_r$. Recall that $\pi_0 D_1$ is also isomorphic to the permutation operad as an operad. Equivalently, the partial composition product $\circ_k : D_1(m) \times D_1(n) \rightarrow D_1(m+n-1)$ maps each cartesian product of connected components $D_1(m)_s \times D_1(n)_t$ into the connected component $D_1(m+n-1)_{s \circ_k t}$, associated to the composition product $s \circ_k t$ of the permutations $s \in \Sigma_m$, $t \in \Sigma_n$, within the permutation operad.

We consider the contractible space $D_1(r)_{id}$ associated to the identity permutation $id \in \Sigma_r$, and the corresponding subspace in $D_2(r)$, which, according to definitions (check §4.1.5), consist of little disc configurations of the form represented in Figure 5.11. We fix such a disc configuration \underline{c}^0 , coming from $D_1(r)_{id}$, as base point for the little 2-disc space $D_2(r)$, and from now on, we use the notation $\check{D}_2(r)$ to refer to the universal covering of $D_2(r)$ formed at that base point.

Any disc configuration \underline{c} coming from the subspace $D_1(r)_{id} \hookrightarrow D_2(r)$ can be connected to our base point \underline{c}^0 by a path γ in that subspace $D_1(r)_{id} \hookrightarrow D_2(r)$. All paths of this form belong to the same homotopy class since $D_1(r)_{id}$ is contractible. Such a path gives a canonical isomorphism between the universal covering of $D_2(r)$ determined at the base point \underline{c} and the universal covering $\check{D}_2(r)$ determined at our chosen base point \underline{c}^0 . We explain this process in the next paragraph where we give an explicit construction of our covering spaces.

5.1.8. *The construction of the universal coverings.* The covering spaces $\check{D}_2(r)$ can actually be built as sets of homotopy classes of paths $\gamma : [0, 1] \rightarrow D_2(r)$ with our base point \underline{c}^0 as origin:

$$\check{D}_2(r) = \{\gamma : [0, 1] \rightarrow D_2(r) \mid \gamma(0) = \underline{c}^0\} / \simeq .$$

We use in this identity a classical construction of the universal covering of a space. We briefly recall the definition of the topology on this space. We refer to standard textbooks (like [132, §V.10]) for details.

The homotopies considered in our definition of the space $\check{D}_2(r)$ consists of continuous families of paths γ_s , $s \in [0, 1]$, which have our base point as origin $\gamma_s(0) = \underline{c}^0$, and which are constant at the end-point $\gamma_s(1) \equiv \underline{c}^1$. We use the notation $[\gamma]$ for the class of a path γ with respect to this homotopy relation.

We consider the map $q : \check{D}_2(r) \rightarrow D_2(r)$ sending (the homotopy class of) a path $\gamma : [0, 1] \rightarrow D_2(r)$ to the end-point $\gamma(1) \in D_2(r)$, and we equip the set $\check{D}_2(r)$ with an appropriate topology so that this map $q : \check{D}_2(r) \rightarrow D_2(r)$ is a covering. We determine this topology by the following process:

- each point $\underline{c} \in D_2(r)$ in the little 2-discs space $D_2(r)$ clearly admits a basis of neighborhoods formed by contractible open sets $U_{\underline{c}, \alpha}$, $\alpha \in \mathcal{J}$;
- to each path $\gamma : [0, 1] \rightarrow D_2(r)$ such that $\gamma(0) = \underline{c}^0$, we associate the collection of sets $\check{U}_{\underline{c}, \alpha} \subset \check{D}_2(r)$ consisting of homotopy classes of paths of the form $\alpha \cdot \gamma$ where α is any path such that $\alpha(0) = \underline{c}$ and lying in $U_{\underline{c}, \alpha}$;
- we take this collection $\check{U}_{\underline{c}, \alpha}$, $\alpha \in \mathcal{J}$, as a basis of open neighborhoods for the element $[\gamma]$ in the space $\check{D}_2(r)$.

This definition is actually forced by the requirement that the counter-image of the set $U_{\underline{c}, \alpha}$ under the covering map $q : \check{D}_2(r) \rightarrow D_2(r)$ is a union of open sets.

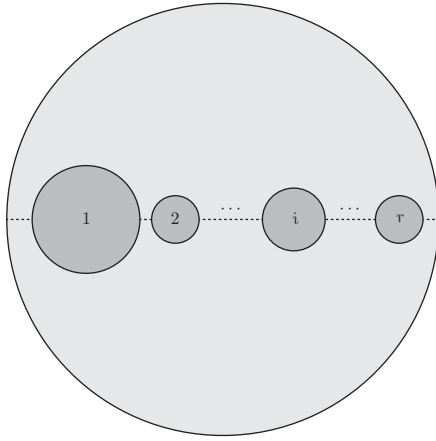

FIGURE 5.11. The form of a chosen base disc configuration, lying in the image of the contractible subspace $D_1(r)_{id} \hookrightarrow D_2(r)$.

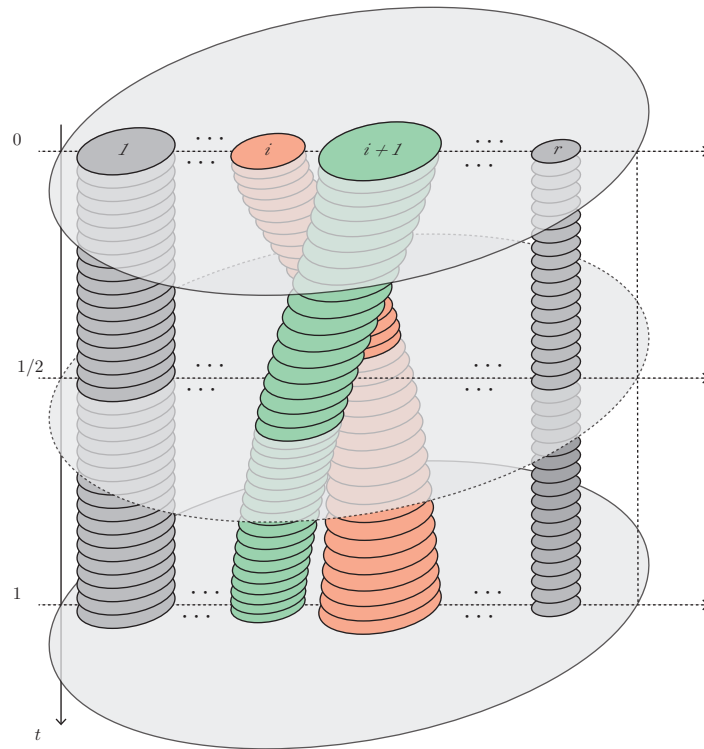

FIGURE 5.12. The path defining a representative of the generating braid τ_i in the little 2-disc space $D_2(r)$.

In what follows, we omit to check the continuity of the maps which we define on covering spaces. These verifications generally reduce to straightforward inspections.

In the construction of this paragraph, the isomorphism connecting the space $\check{D}_2(r)$ with the universal covering taken at another base point \underline{c} is given by the concatenation of the paths $\gamma : [0, 1] \rightarrow D_2(r)$, defining the elements of the covering space $\check{D}_2(r)$, with a path $\gamma^0 : [0, 1] \rightarrow D_2(r)$ such that $\gamma^0(0) = \underline{c}$ and $\gamma^0(1) = \underline{c}^0$. From this construction, we immediately see that this isomorphism is canonical as soon as the homotopy class of the path γ^0 connecting the base points is uniquely determined, and this is so when, as set in §5.1.7, we restrict ourselves to base points \underline{c}^0 lying within the component $D_1(r)_{id}$ of the little 1-disc space $D_1(r)$ inside $D_2(r)$.

5.1.9. *The action of braid groups.* The pure braid group P_r can immediately be identified with the group of automorphisms of the covering $\check{D}_2(r) \rightarrow D_2(r)$ because:

- the automorphism group of a universal covering is identified with the fundamental group of its base space,
- and the homotopy equivalence $\omega : D_2(r) \xrightarrow{\sim} F(\mathbb{D}^2, r)$, defined by the disc center mapping, induces a group isomorphism

$$\pi_1(D_2(r), *) \xrightarrow{\sim} \pi_1(F(\mathbb{D}^2, r), *) = P_r.$$

One can adapt this approach in order to prove that the action of P_r on $\check{D}_2(r)$ extends to an action of the full braid group B_r . Indeed, we can also identify our covering space $\check{D}_2(r)$ with the universal covering of the quotient space $D_2(r)/\Sigma_r$, for which we have $\pi_1(D_2(r)/\Sigma_r, *) \xrightarrow{\sim} \pi_1(F(\mathbb{D}^2, r)/\Sigma_r, *) = B_r$.

In order to ease the subsequent proof of operad equivariance relations on our covering spaces $\check{D}_2(r)$, we prefer to give an explicit construction of this action. For this aim, we rely on our explicit definition of the universal covering $\check{D}_2(r)$, in §5.1.8. We consider a path in the little 2-disc space $\tau_i : [0, 1] \rightarrow D_2(r)$ of the form represented in Figure 5.12. We immediately see from our picture that the image of this path under the disc center mapping $\omega : D_2(r) \rightarrow F(\mathbb{D}^2, r)$ is a representative of the generating braid of Figure 5.5.

Note that the endpoint of this path $\tau_i(1)$ is identified with the image of our base disc configuration \underline{c}^0 under the action of the transposition $t_i = (i \ i + 1)$.

Let now $\gamma : [0, 1] \rightarrow D_2(r)$ be a path in $D_2(r)$ with $\gamma(0) = \underline{c}^0$ as origin so that the homotopy class of this path $[\gamma]$ defines an element of the covering space $\check{D}_2(r)$. We apply the transposition t_i to this path in order to obtain a path $t_i\gamma$ with $t_i\gamma(0) = t_i \cdot \underline{c}^0$ as origin. We can then concatenate $t_i\gamma$ with the path represented in Figure 5.12 to obtain a new path $(t_i\gamma) \cdot \tau_i : [0, 1] \rightarrow D_2(r)$ with \underline{c}^0 as origin, and of which homotopy class $[(t_i\gamma) \cdot \tau_i]$ determines an element of $\check{D}_2(r)$ associated to the class $[\gamma]$.

By an immediate visual inspection, we obtain that:

LEMMA 5.1.10.

- (a) *The mapping $\tau_i : [\gamma] \mapsto [(t_i\gamma) \cdot \tau_i]$ defines a lifting, to the space $\check{D}_2(r)$, of the map $t_i : D_2(r) \rightarrow D_2(r)$ defining the action of the transposition $t_i = (i \ i + 1)$ on the little 2-disc space.*
- (b) *The maps $\tau_i : \check{D}_2(r) \rightarrow \check{D}_2(r)$, obtained by this construction for $i = 1, \dots, r - 1$, satisfy the generating relations of braids groups, and hence, determine an action of the braid group B_r on the covering space $\check{D}_2(r)$. \square*

This result completes the construction of the braided structure on the collection of spaces $\check{D}_2 = \{\check{D}_2(r)\}_{r \in \mathbb{N}}$.

We can use a similar composition process $[\gamma] \mapsto [\gamma \cdot \omega]$ when $\omega : [0, 1] \rightarrow D_2(r)$ is any loop based at $\omega(0) = \omega(1) = \underline{c}^0$ in order to determine the action of the fundamental group $\pi_1(D_2(r), \underline{c}^0)$ on the universal covering $\check{D}_2(r)$. We immediately see that this action corresponds to a restriction of the action considered in Lemma 5.1.10 when we apply the isomorphism $\pi_1(D_2(r), *) \xrightarrow{\cong} \pi_1(F(\mathbb{D}^2, r), *)$ to identify $\pi_1(D_2(r), *)$ with the pure braid group P_r .

The following statement follows from this identification and standard results of covering theory:

LEMMA 5.1.11. *The covering map $q : \check{D}_2(r) \rightarrow D_2(r)$, defined in §5.1.8, induces a homeomorphism $q_* : \check{D}_2(r)/P_r \xrightarrow{\cong} D_2(r)$, where the quotient space $\check{D}_2(r)/P_r$ is formed by considering the restriction of the action of Lemma 5.1.10 to the pure braid group P_r . \square*

5.1.12. *The operadic composition structure.* We now aim at providing the collection \check{D}_2 with an operadic composition structure.

We can assume that our base point in arity $r = 1$ is given by the operadic unit of the little 2-disc operad $1 \in D_2(1)$. We take the homotopy class of the constant path $1(t) = 1$ associated to this element $1 \in D_2(1)$ as operadic unit for \check{D}_2 .

We proceed as follows to define the composition products of \check{D}_2 . Let $\alpha : [0, 1] \rightarrow D_2(m)$ (respectively, $\beta : [0, 1] \rightarrow D_2(n)$) be a path defining an element in the covering space $\check{D}_2(m)$ (respectively, $\check{D}_2(n)$). Let $\underline{a}^0 = \alpha(0)$ (respectively, $\underline{b}^0 = \beta(0)$) be the base point in the little 2-discs space $D_2(m)$ (respectively, $D_2(n)$) underlying this covering. We fix a composition index $k \in \{1, \dots, m\}$. By performing the operadic composition of little 2-discs point-wise, we obtain a path $\alpha \circ_k \beta : [0, 1] \rightarrow D_2(m+n-1)$ with $\alpha \circ_k \beta(0) = \underline{a}^0 \circ_k \underline{b}^0$ as origin. This composite little discs configuration $\underline{a}^0 \circ_k \underline{b}^0$ is not necessarily equal to the chosen base point \underline{c}^0 of the little 2-disc space $D_2(m+n-1)$. But, the assumption that \underline{a}^0 lies in the contractible space $D_1(m)_{id} \hookrightarrow D_2(m)$, and that \underline{b}^0 similarly arises from $D_1(n)_{id} \hookrightarrow D_2(n)$ implies that $\underline{a}^0 \circ_k \underline{b}^0$ lies in our distinguished subspace $D_1(m+n-1)_{id}$ too, because the composition of these connected components is reflected by the composition structure of the permutation operad where we have $id \circ_k id = id$ (see Proposition 1.1.9). Thus, as we explain in §5.1.7, we have a path $\gamma^0 : [0, 1] \rightarrow D_2(m+n-1)$, going from $\gamma^0(0) = \underline{c}^0$ to $\gamma^0(1) = \underline{a}^0 \circ_k \underline{b}^0$, and with a well determined homotopy class. We concatenate our composite $\alpha \circ_k \beta$ with such a path $\gamma^0 : [0, 1] \rightarrow D_2(m+n-1)$. The homotopy class $[\alpha \circ_k \beta \cdot \gamma^0]$ defines an element of $\check{D}_2(m+n-1)$ naturally associated to $[\alpha] \in \check{D}_2(m+n-1)$ and $[\beta] \in \check{D}_2(m+n-1)$. We obtain by this process a composition product on our universal coverings

$$\circ_k : \check{D}_2(m) \times \check{D}_2(n) \rightarrow \check{D}_2(m+n-1)$$

which obviously lifts the composition product \circ_k of the little 2-discs operad. We prove that:

LEMMA 5.1.13. *The operadic unit and composition products defined on the covering spaces $\check{D}_2(r)$ in the previous paragraphs fulfill the unit and associativity requirements of operadic composition structures, as well as the equivariance relation of braided operad.*

PROOF. The proof of the unit and associativity relations of composition products follows from a quick visual inspection. The equivariance relation is checked similarly in the case of a generating braid τ_i by going back to the definition of the action of these elements in §§5.1.9-5.1.10. The verification of this case suffices to prove the equivariance relation in full generality. \square

The covering maps $q : \check{D}_2(r) \rightarrow D_2(r)$ clearly define a morphism of braided operads $q : \check{D}_2 \rightarrow D_2$. The assertion of Lemma 5.1.11 also implies that this morphism induces an isomorphism between the symmetrized operad $\text{Sym } \check{D}_2$ and D_2 , and this verification finishes the proof of Theorem 5.1.6. \square

Theorem 5.1.6 has the following consequence:

THEOREM 5.1.14 (Z. Fiedorowicz [56]). *Let P be a braided operad in topological spaces. Suppose that the action of B_r on $P(r)$ is free and proper, for all $r \in \mathbb{N}$. If the spaces $P(r)$ are contractible for all $r \in \mathbb{N}$, then the symmetric operad naturally associated to P , and formed by the collection of quotient spaces $\text{Sym } P(r) = P(r)/P_r$, is an E_2 -operad. This result has an obvious extension in the unitary setting.*

PROOF. We again focus on the non-unitary setting because the generalization of our statement to unitary operads follows from a straightforward extension of our arguments.

We form the arity-wise product $Q(r) = P(r) \times \check{D}_2(r)$ in the category of braided operads. The braid group B_r operates diagonally on $Q(r)$, for each $r \in \mathbb{N}$, and we equip the collection $Q = \{Q(r)\}_{r \in \mathbb{N}}$ with the obvious operad structure so that the canonical projections

$$P(r) \leftarrow P(r) \times \check{D}_2(r) \rightarrow \check{D}_2(r)$$

define morphisms of braided operads $P \leftarrow Q \rightarrow \check{D}_2$.

Recall that the spaces $P(r)$ are contractible by assumption, and we have already observed that the spaces $\check{D}_2(r)$ are contractible too. Thus, the considered projections are weak-equivalences between contractible spaces.

The braid group B_r operates freely and properly on $P(r)$ by assumption, and on $\check{D}_2(r)$ as well by definition of this space as a universal covering. The diagonal action of B_r on $P(r) \times \check{D}_2(r)$ is free and proper too. By performing the quotient over the action of $P_r \subset B_r$, we accordingly obtain weak-equivalences of spaces

$$P(r)/P_r \xleftarrow{\sim} (P(r) \times \check{D}_2(r))/P_r \xrightarrow{\sim} \check{D}_2(r)/P_r = D_2(r),$$

and these weak-equivalences define a chain of morphisms of symmetric operads $\text{Sym } P \xleftarrow{\sim} \text{Sym } Q \xrightarrow{\sim} D_2$. The conclusion of the theorem follows. \square

5.2. The classifying spaces of the colored braid operad

Recall that an Eilenberg-MacLane space of type $K(G, 1)$, where G is any group, is a connected space X such that $\pi_1(X) = G$ and $\pi_*(X) = 0$ for $* \neq 1$. These conditions determine the homotopy type of the space X : all Eilenberg-MacLane spaces of a given type $K(G, 1)$ are weakly-equivalent.

In the preliminary section §5.0, we mentioned that the underlying spaces of the little 2-discs operad D_2 are Eilenberg-MacLane spaces $K(P_r, 1)$ associated to the pure braid groups P_r . This result follows from the existence of the homotopy equivalence $D_2(r) \xrightarrow{\sim} F(\mathbb{D}^2, r)$, established in Proposition 4.2.2, and the computation of the homotopy groups of the configuration spaces $F(\mathbb{D}^2, r)$ in Proposition 5.0.1.

In topology, we have a standard simplicial model BG for the Eilenberg-MacLane space $K(G, 1)$. This simplicial set BG also represents the base space of a universal G -principal bundle, and for that reason, is usually referred to as the classifying space of G .

The objective of this section is to define a classifying space model of the little 2-disc operad D_2 . But we do not have a full operad structure on the collection of pure braid groups. To get our model, we have to consider an extension of the classifying space construction to groupoids and to operad in groupoids. We precisely construct a collection of groupoids, the colored braid groupoids $CoB(r)$, which include the pure braid groups P_r as automorphism groups of objects, and form an operad in the category of groupoids. We prove that the collection of classifying spaces $B CoB(r)$ associated to this operad forms a model of E_2 -operad.

To begin with, we make explicit the definition of an operad in the category of small categories and in the category of groupoids. Then we recall the definition of the classifying space of a category, and we examine the application of this classifying space construction to operads in categories. We define the colored braid operad afterwards, as an instance of operad in groupoids.

5.2.1. *The category of small categories and groupoids.* We use the notation Cat for the category of small categories. The cartesian product of categories defines the underlying product $\times : Cat \times Cat \rightarrow Cat$ of a symmetric monoidal structure on Cat . The one-point set pt , which is identified with the final object of the category of small categories, defines the unit object associated with this symmetric monoidal structure. We may identify sets with discrete categories, which have no morphism outside the identity attached to each object.

We basically define a groupoid is a small category in which all morphisms are invertible. We may identify groups with groupoids of which underlying object set is reduced to a point. We use the notation Grd for the category of groupoids which, according to our definition, form a full subcategory of the category of small categories. We immediately see that the embedding $Grd \hookrightarrow Cat$ creates products and final objects. The category of groupoids Grd forms, therefore, a symmetric monoidal subcategory of the category of small categories Cat .

5.2.2. *Operads in small categories and in groupoids.* We define the category of operads in the category of small categories as an instance of a category of operads in a symmetric monoidal category, and similarly in the case of operads in groupoids. An operad in the category of small categories P (we also say operad in categories for short) accordingly consists of a sequence of small categories $P(r) \in Cat$, $r \in \mathbb{N}$, equipped with an action of the symmetric groups Σ_r , together with a unit morphism $\eta : pt \rightarrow P(1)$, and composition products $\mu : P(r) \times P(n_1) \times \cdots \times P(n_r) \rightarrow P(n_1 + \cdots + n_r)$, all formed in the category of categories, and satisfying our usual equivariance, unit and associativity relations. Since the category of groupoids forms a symmetric monoidal subcategory of the category of small categories, an operad in groupoids can be defined as an operad in categories P of which components $P(r)$ are groupoids.

The equivalence between the plain definition of an operad (§1.1) and the definition in terms of partial composition operations (§3.1) naturally holds in the context of categories $\mathcal{M} = Cat$ (respectively, groupoids $\mathcal{M} = Grd$). Hence, the composition structure of an operad in categories (respectively, groupoids) can be defined by

giving a collection of functors $\circ_k : P(m) \times P(n) \rightarrow P(m+n-1)$, $k = 1, \dots, m$, satisfying the equivariance, unit and associativity relations of §3.1.

The category of operads in categories is denoted by CatOp (following our notation conventions for operad categories). By definition, a morphism of operads in categories $f : P \rightarrow Q$ consists of a sequence of functors $f : P(r) \rightarrow Q(r)$ preserving the internal structures of our operads. The category of operads in groupoids, also denoted by GrdOp , forms a full subcategory of the category of operads in categories.

In the category of small categories, one distinguishes the class of equivalences (functors which are invertible up to natural equivalence) in addition to isomorphisms (the functors which are strictly invertible). For operads in categories, we will naturally consider operad morphisms $f : P \rightarrow Q$ of which all underlying functors $f : P(r) \rightarrow Q(r)$ are equivalences of categories. In this situation, we will say that the operad morphism f is a categorical equivalence, and we will use the distinguishing mark \sim in the notation of f . Note that the inverse equivalences of the functors $f : P(r) \xrightarrow{\sim} Q(r)$ do not necessarily define an operad morphism in general, and we do not assume that such a property holds in our definition of a categorical equivalence of operads.

5.2.3. *Recollections on classifying spaces.* The classifying space of a category \mathcal{C} is the simplicial set $\mathbf{B}\mathcal{C}$ defined in dimension n by the n -fold sequences of composable morphisms of \mathcal{C}

$$\underline{\alpha} = \{x_0 \xrightarrow{\alpha_1} x_1 \xrightarrow{\alpha_2} \dots \xrightarrow{\alpha_n} x_n\}$$

together with the face operators such that

$$\begin{aligned} d_0(\underline{\alpha}) &= x_1 \xrightarrow{\alpha_2} \dots \xrightarrow{\alpha_n} x_n, \\ d_i(\underline{\alpha}) &= x_0 \xrightarrow{\alpha_1} \dots \xrightarrow{\alpha_{i-1}} x_{i-1} \xrightarrow{\alpha_{i+1}\alpha_i} x_{i+1} \xrightarrow{\alpha_{i+2}} \dots \xrightarrow{\alpha_n} x_n, \quad \text{for } 0 < i < n, \\ d_n(\underline{\alpha}) &= x_0 \xrightarrow{\alpha_1} \dots \xrightarrow{\alpha_{n-1}} x_{n-1}, \end{aligned}$$

and the degeneracy operators given by the insertion of identity morphisms

$$s_j(\underline{\alpha}) = x_0 \xrightarrow{\alpha_1} \dots \xrightarrow{\alpha_j} x_j \xrightarrow{id} x_j \xrightarrow{\alpha_{j+1}} \dots \xrightarrow{\alpha_n} x_n,$$

for all $j = 0, \dots, n$. One can prove that the simplicial set $\mathbf{B}\mathcal{C}$ forms a Kan complex if and only if the category \mathcal{C} is a groupoid (see for instance [78, §I.3]). In the case of a group G , this result can be used to check, by a direct and simple computation, that the geometric realization of BG is an Eilenberg-MacLane space (use the combinatorial definition of simplicial homotopy groups in [43, §2] or in [133, §1]).

The mapping $\mathbf{B} : \mathcal{C} \mapsto \mathbf{B}\mathcal{C}$ defines a functor from the category of small categories to the category of simplicial sets. To study the image of operads in categories under the classifying space construction, we use the following result:

PROPOSITION 5.2.4. *The functor $\mathbf{B} : \mathit{Cat} \rightarrow \mathit{Simp}$ is symmetric monoidal in the sense of §2.3.1:*

- (a) *for a point pt , viewed as the unit object of the category of small categories, we have an obvious identity $\mathbf{B}(pt) = pt$;*
- (b) *for a cartesian product of categories $\mathcal{C} \times \mathcal{D}$, the maps $\mathbf{B}\mathcal{C} \xleftarrow{p^*} \mathbf{B}(\mathcal{C} \times \mathcal{D}) \xrightarrow{q^*} \mathbf{B}\mathcal{D}$, induced by the canonical projections $\mathcal{C} \xleftarrow{p} \mathcal{C} \times \mathcal{D} \xrightarrow{q} \mathcal{D}$, give rise to an isomorphism $\mathbf{B}(\mathcal{C} \times \mathcal{D}) \xrightarrow{\cong} \mathbf{B}\mathcal{C} \times \mathbf{B}\mathcal{D}$;*
- (c) *and these comparison isomorphisms (a-b) fulfill the unit, associativity and symmetry constraints of §2.3.1.*

PROOF. The proof of assertions (a-b) reduces to a straightforward inspection of definitions. The definition of the isomorphism $\mathbf{B}(\mathcal{C} \times \mathcal{D}) \xrightarrow{\cong} \mathbf{B}\mathcal{C} \times \mathbf{B}\mathcal{D}$ from universal categorical constructions automatically ensures that the unit, associativity and symmetry constraints of §2.3.1 are fulfilled. \square

From this statement, the result of Proposition 2.1.4 gives:

PROPOSITION 5.2.5. *Let P be an operad in small categories. The collection of classifying spaces $\mathbf{B}P(r)$ associated to the categories $P(r)$ forms an operad in simplicial sets naturally associated to P .* \square

Recall that, in the situation of Proposition 5.2.4, the mapping $\mathbf{B} : P \mapsto \mathbf{B}P$ preserves unitary extensions, so that we have an identity $\mathbf{B}(P_+) = (\mathbf{B}P)_+$ for any unitary operad in the category of small categories P_+ (see Proposition 2.1.4).

In §2.3.2, we observe that the geometric realization functor $|-| : \mathit{Simp} \rightarrow \mathit{Top}$ is symmetric monoidal as well. We can apply this functor to the simplicial operad $\mathbf{B}P$ in order to form a classifying space operad in topological spaces naturally associated to P . In general, we abusively use the notation of the underlying simplicial operad $\mathbf{B}P$ for this associated operad in topological spaces too. We only mark the application of the realization functor $|-|$ when the context requires to distinguish the topological object from its simplicial counterpart.

The mapping $\mathbf{B} : P \mapsto \mathbf{B}P$ defines a functor from the category of operads in the category of small categories to the category of operads in simplicial sets. In §4, we introduced a notion of weak-equivalence for the category of operads in topological spaces. In the simplicial framework, we consider weak-equivalences of simplicial sets, consisting of maps $f : X \rightarrow Y$ of which topological realization $|f| : |X| \rightarrow |Y|$ defines a weak-equivalence of topological spaces, and we similarly say that an operad morphism $\phi : P \rightarrow Q$ is a weak-equivalence if each component of this morphism $\phi(r) : P(r) \rightarrow Q(r)$ defines a weak-equivalence of simplicial sets. From this definition, we immediately see that a morphism of operads in simplicial sets is a weak-equivalence $\phi : P \xrightarrow{\sim} Q$ if and only if the topological realization of this morphism defines a weak-equivalence of operads in topological spaces $|\phi| : |P| \xrightarrow{\sim} |Q|$.

The following proposition, which is an immediate corollary of a standard result on classifying spaces, is worth recording:

PROPOSITION 5.2.6. *The morphism $\mathbf{B}f : \mathbf{B}P \rightarrow \mathbf{B}Q$ associated to a categorical equivalence of operads $f : P \xrightarrow{\sim} Q$ is a weak-equivalence of simplicial operads.* \square

The rest of this section is devoted to the definition of the colored braid operad CoB and to the proof that the associated classifying space operad $\mathbf{B}\mathit{CoB}$ defines an instance of E_2 -operad. We also establish a unitary extension of this result. In a first step, we define the underlying groupoids of this operad.

In §5.2.1, we define a small category by an object set $\mathit{Ob}\mathcal{C}$ together with morphism sets $\mathit{Mor}_{\mathcal{C}}(x, y)$, associated to all pairs of objects $x, y \in \mathit{Ob}\mathcal{C}$, and we adopt the same approach for the definition of groupoids, which we regard as categories \mathcal{G} where all morphisms are isomorphisms. But for the definition of the groupoid of colored braids $\mathit{CoB}(r)$, we follow another approach, because all the information is carried by the morphisms. In short, we consider that $\mathit{CoB}(r)$ is formed of an object set $\mathit{Ob}\mathit{CoB}(r)$ and a single morphism set $\mathit{Mor}\mathit{CoB}(r)$ collecting all morphisms of our groupoid. We give a definition of the colored braid groupoid along these lines

first. We make explicit the morphism set $\text{Mor}_{\text{CoB}(r)}(u, v)$, associated to each pair of objects $u, v \in \text{Ob CoB}(r)$, and the equivalence between this initial definition of our groupoid $\text{CoB}(r)$ and the structures considered in §5.2.1, in a second step.

We adopt a parallel plan all along this section, when we address the definition the symmetric and composition structure of the operad formed by our groupoids $\text{CoB}(r)$, $r \in \mathbb{N}$.

5.2.7. *Groupoids revisited.* In a preliminary step, we explain the general definition of a groupoid structure \mathcal{G} from an object set $\text{Ob } \mathcal{G}$ and a single morphism set $\text{Mor } \mathcal{G}$ collecting all morphisms of the groupoid.

In this approach, we assume the existence of maps $s, t : \text{Mor } \mathcal{G} \rightarrow \text{Ob } \mathcal{G}$, determining the source and target of the morphisms in \mathcal{G} , as well as the existence of a map $e : \text{Ob } \mathcal{G} \rightarrow \text{Mor } \mathcal{G}$, which determines the identity morphism associated to each object. We also assume that these maps satisfy the relation $se = te = id$. The morphism sets $\text{Mor}_{\mathcal{G}}(x, y)$, which we have considered so far, are identified with the subsets of morphisms $\alpha \in \text{Mor } \mathcal{G}$ associated to a given source $s(\alpha) = x$ and target object $t(\alpha) = y$.

The fiber product

$$\begin{array}{ccc} \text{Mor } \mathcal{G} \times_{st} \text{Mor } \mathcal{G} & \xrightarrow{q} & \text{Mor } \mathcal{G} \\ \downarrow p & & \downarrow t \\ \text{Mor } \mathcal{G} & \xrightarrow{s} & \text{Ob } \mathcal{G} \end{array}$$

more explicitly defined as the set $\text{Mor } \mathcal{G} \times_{st} \text{Mor } \mathcal{G} = \{(\alpha, \beta) | s(\alpha) = t(\beta)\}$, collects all pairs of composable morphisms of the groupoid. The composition operation of \mathcal{G} is given by a product operation $\mu : \text{Mor } \mathcal{G} \times_{st} \text{Mor } \mathcal{G} \rightarrow \text{Mor } \mathcal{G}$, defined on this fiber product, and such that $s\mu = sq$, $t\mu = tp$. In point-wise terms, these requirements read $s(\alpha\beta) = s(\beta)$ and $t(\alpha\beta) = t(\alpha)$ for all composable morphisms $(\alpha, \beta) \in \text{Mor } \mathcal{G} \times_{st} \text{Mor } \mathcal{G}$, where we set $\alpha\beta = \mu(\alpha, \beta)$.

To define the inverse of morphisms in a groupoid, we similarly consider a map $\iota : \text{Mor } \mathcal{G} \rightarrow \text{Mor } \mathcal{G}$ such that $s\iota = t$ and $t\iota = s$. The unit, associativity, and inverse relations of the composition structure of groupoids can be written in terms of commutative diagrams, involving the fiber product $\text{Mor } \mathcal{G} \times_{st} \text{Mor } \mathcal{G}$. But, since we define the product and inversion maps of our groupoids as point-set mappings, we are just going to use the basic point-set interpretation of these relations.

5.2.8. *The groupoids of colored braids.* The object set $\text{Ob CoB}(r)$ of the r th colored braid groupoid $\text{CoB}(r)$ is the set of permutations $w \in \Sigma_r$ which we regard as ordered sequences $(w(1), \dots, w(r))$ of integers $w(i) \in \{1, \dots, r\}$. The morphism set $\text{Mor CoB}(r)$ consists of isotopy classes of braids α equipped with a bijection between $\{1, \dots, r\}$ and the collection of strands $\{\alpha_1, \dots, \alpha_r\}$ underlying the braid α . Intuitively, the extra bijection assigns a color $i \in \{1, \dots, r\}$ to each strand α_i , and this interpretation motivates the name of colored braid which we adopt for our groupoid.

In §5.0.5, we consider that the strands of a braid form an r -tuple $(\alpha_1, \dots, \alpha_r)$ arranged according to the ordering of the points $(\alpha_1(0), \dots, \alpha_r(0))$ on the axis $(y = 0, t = 0)$. In the colored braid case, we rather consider the ordering equivalent to the bijection $i \mapsto \alpha_i$ given together with our braid α . Thus, we have $(\alpha_1(0), \dots, \alpha_r(0)) = ((x_{u(1)}^0, 0, 0), \dots, (x_{u(r)}^0, 0, 0))$ for some permutation $u \in \Sigma_r$, where we again use the notation x_k^0 , $k = 1, \dots, r$, for the abscissa of our contact

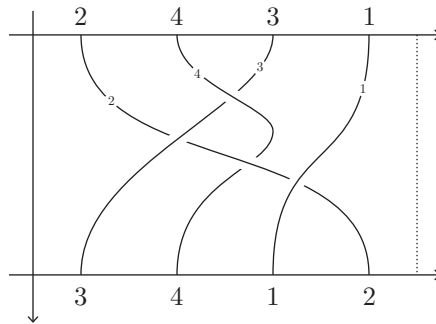

FIGURE 5.13. An instance of colored braid.

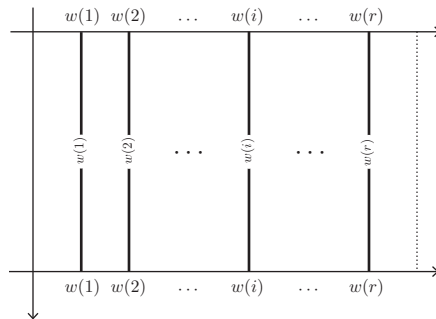

FIGURE 5.14. The representation of identity elements in the groupoid of colored braids.

points on the axis $y = 0$ (see §5.0.5). This permutation defines the source of our braid $u = s(\alpha)$ in the groupoid $\mathit{CoB}(r)$. The target of the braid $v = t(\alpha)$ is the permutation v such that $(\alpha_1(1), \dots, \alpha_r(1)) = ((x_{v(1)}^0, 0, 1), \dots, (x_{v(r)}^0, 0, 1))$. Intuitively, we simply take the ordering of the origin points of the strands on the axis $(y = 0, t = 0)$ to determine a color ordering yielding the source permutation u of the colored braid α , and we take the ordering of the end points of the strands on the axis $(y = 0, t = 1)$ to determine another color ordering yielding our target permutation v .

To illustrate these definitions, we give an instance of a colored braid in Figure 5.13. The source and target permutations associated to this colored braid are given by the ordered sequences $u = (2, 4, 3, 1)$ and $v = (3, 4, 1, 2)$.

The identity morphism $id_w = e(w)$ assigned to any permutation $w \in \Sigma_r$ is defined by the identity braid whose strands α_i are equipped with the coloring determined by the permutation $w = (w(1), \dots, w(r))$ so that we have $\alpha_{w(i)}(t) = (x_i^0, 0, t)$, for any $i = 1, \dots, r$ (see Figure 5.14).

The composition of the groupoid is given by the standard concatenation operation on braids, inherited from the braid group, and represented in Figure 5.3. In our new context, we simply note that the colors assigned to strands agree on contact points precisely when our braids (α, β) satisfy the relation $s(\alpha) = t(\beta)$ and hence are composable in the sense of §5.2.7. In this situation, each composite strand

inherits a single color from its components, which we use to define the coloring of the composite braid $\alpha \cdot \beta$.

The inversion of colored braids can also be deduced from the inversion operation of the braid groups.

5.2.9. *Braid cosets and morphisms in the colored braid groupoids.* In the previous paragraph, we chose an approach which provides an intuitive definition of the colored braid groupoid. On the other hand, we immediately see, from this first definition, that the color indexing of an element $\alpha \in \mathbf{CoB}(r)$ is determined by giving the permutation $u = s(\alpha)$, which represents the source of the morphism α in the colored braid groupoid. Indeed, the ordered sequence $u = (u(1), \dots, u(r))$ corresponds to the color indexing of the origin points $((x_1^0, 0, 0), \dots, (x_r^0, 0, 0))$, which in turn determines the coloring of the braid strands. By using this observation, we can readily identify the morphism set $\mathbf{Mor}_{\mathbf{CoB}(r)}(u, v)$ associated to fixed permutations $u, v \in \Sigma_r$ with the coset $q_*^{-1}(v^{-1}u) \subset B_r$, where we consider the natural group morphism $q_* : B_r \rightarrow \Sigma_r$ from braids to permutations. The composition operation of $\mathbf{CoB}(r)$ is also identified with the operation $q_*^{-1}(w^{-1}v) \times q_*^{-1}(v^{-1}u) \rightarrow q_*^{-1}(w^{-1}u)$ obtained by restriction of the natural multiplication of the braid group B_r . For a single permutation $w \in \Sigma_r$, we have an identity $\mathbf{Mor}_{\mathbf{CoB}(r)}(w, w) = q_*^{-1}(w^{-1}w) = P_r$, and the identity morphism associated to w in the groupoid corresponds to the neutral element of the pure braid group P_r .

5.2.10. *The symmetric structure of the colored braid groupoids.* Each groupoid of colored braids $\mathbf{CoB}(r)$ inherits a natural action of permutations. Therefore the collection $\mathbf{CoB} = \{\mathbf{CoB}(r), r \in \mathbb{N}\}$ forms a symmetric sequence of groupoids. To be explicit, the groupoid morphism $s_* : \mathbf{CoB}(r) \rightarrow \mathbf{CoB}(r)$ associated to any $s \in \Sigma_r$ is defined by the following process: for a permutation $w \in \Sigma_r$, representing an object of $\mathbf{CoB}(r)$, we set $s_*(w) = sw$; for a braid α equipped with a strand coloring $i \mapsto \alpha_i$, we define $s_*(\alpha)$ by the same underlying braid as α , but we equip $s_*(\alpha)$ with the modified coloring $s(i) \mapsto \alpha_i$ which assigns the value $s(i) \in \{1, \dots, r\}$ to the strand α_i which was previously colored by the index $i \in \{1, \dots, r\}$. The mappings $s_* : \mathbf{Mor}_{\mathbf{CoB}(r)} \rightarrow \mathbf{Mor}_{\mathbf{CoB}(r)}$ and $s_* : \mathbf{Ob}_{\mathbf{CoB}(r)} \rightarrow \mathbf{Ob}_{\mathbf{CoB}(r)}$ clearly preserve the structure morphisms attached to our groupoid. In the definition of §5.2.9, the mapping $s_* : \mathbf{Mor}_{\mathbf{CoB}(r)}(u, v) \rightarrow \mathbf{Mor}_{\mathbf{CoB}(r)}(s_*(u), s_*(v))$ is given by the identity of the coset $q_*^{-1}(s_*(v)^{-1}s_*(u)) = q_*^{-1}((sv)^{-1}(su)) = q_*^{-1}(v^{-1}u) \subset B_r$ with which both morphism sets $\mathbf{Mor}_{\mathbf{CoB}(r)}(u, v)$ and $\mathbf{Mor}_{\mathbf{CoB}(r)}(s_*(u), s_*(v))$ are identified.

5.2.11. *The operadic composition operations on colored braids.* We have an obvious identity $\mathbf{CoB}(1) = pt$, giving a canonical operadic unit in the colored braid groupoids. We also have operadic composition operations, deduced from the operadic composition of permutations and braids, so that \mathbf{CoB} inherits a full operad structure. We proceed as follows to define these operations.

On object sets $\mathbf{Ob}_{\mathbf{CoB}(r)} = \Sigma_r$, we simply use the operadic composition of permutations. (Accordingly, the collection $\mathbf{Ob}_{\mathbf{CoB}}$ is identified with the permutation operad in the category of sets.) On morphism sets $\mathbf{Mor}_{\mathbf{CoB}(r)}$, we use the operadic composition of braids, defined in §§5.1.2-5.1.3, together with an operadic composition of the braid colorings which we define as follows.

Let $\alpha \in \mathbf{Mor}_{\mathbf{CoB}(m)}$ and $\beta \in \mathbf{Mor}_{\mathbf{CoB}(n)}$ be colored braids. Intuitively, to define the composite $\alpha \circ_k \beta \in \mathbf{Mor}_{\mathbf{CoB}(m+n-1)}$, we insert the k th input braid β in the strand of α colored by $k \in \{1, \dots, m\}$. We also apply the standard operadic shift $i \mapsto i+k-1$ to the index of the strands of β in the composite braid, the shift

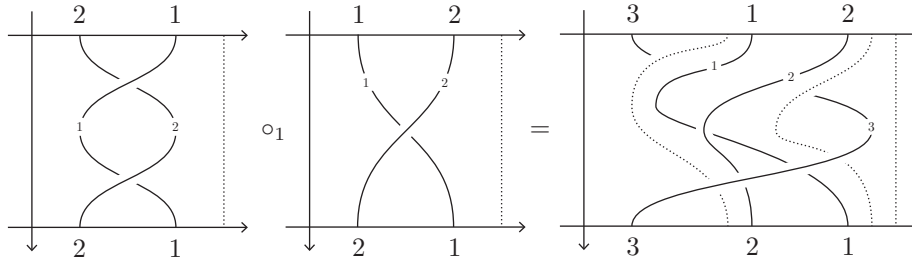

FIGURE 5.15. An operadic composition of colored braids

$i \mapsto i + n - 1$ to the index of the strands of α when $k < i$, and this gives the coloring of $\alpha \circ_k \beta$. In comparison with the process of §§5.1.2-5.1.3, we simply use an ordering defined by the color indexing of the strands of α instead of the natural ordering of the source points on the line $y = t = 0$. Thus, the composition of braids in the colored braid groupoid is formally defined by the composition operation of §§5.1.2-5.1.3 up to an input reordering, which we determine from the source permutation of the braid α . To illustrate this process, we give an instance of partial composition operation $\alpha \circ_1 \beta = \alpha(\beta, 1)$ in Figure 5.15. In order to ease the understanding of this picture, we have added dotted lines marking the array in which the braid β is inserted.

In the coset representation of morphism sets (§5.2.9), the partial composite $\text{Mor}_{\text{CoB}(m)}(s, t) \times \text{Mor}_{\text{CoB}(n)}(u, v) \xrightarrow{\circ_k} \text{Mor}_{\text{CoB}(m+n-1)}(s \circ_k u, t \circ_k v)$ maps elements $\alpha \in q_*^{-1}(t^{-1}s)$ and $\beta \in q_*^{-1}(v^{-1}u)$ to the composite braid $\alpha \circ_{s^{-1}(k)} \beta$ which has $q_*(\alpha \circ_{s^{-1}(k)} \beta) = (t \circ_k v)^{-1} \cdot (s \circ_k u)$ as associated permutation. This operation obviously preserves the groupoid structure, and hence, gives a morphism $\circ_k : \text{CoB}(m) \times \text{CoB}(n) \rightarrow \text{CoB}(m+n-1)$ in the category of groupoids.

The verification of the operad axioms is straightforward from the results obtained for the braid operad in §5.1.

The construction of this composition clearly extends to the degenerate case of a colored braid β with an empty set of strands, and we readily deduce from this observation that the operad CoB has a unitary extension CoB_+ . The restriction operation $u^* : \text{CoB}_+(n) \rightarrow \text{CoB}_+(m)$ can actually be identified with a natural generalization to colored braids of the removal operations on braid groups, as described in §5.1.4, just like the operadic composition of colored braids define a generalization of the operadic composition of braids.

The definition of the colored braid operad is now complete and we aim to prove:

THEOREM 5.2.12. *The classifying space operad $\mathbf{B}(\text{CoB})$ associated to the operad of colored braids CoB is an E_2 -operad, and the operad $\mathbf{B}(\text{CoB})_+$, associated to the unitary extension of CoB , similarly defines an instance of a unitary E_2 -operad.*

We focus on the non-unitary context. The unitary extension of our statement follows, again, from a straightforward adaptation of the arguments.

The idea is to identify $\mathbf{B}(\text{CoB})$ with the symmetrization of a contractible braided operad in order to deduce Theorem 5.2.12 from the recognition theorem of §5.1. This contractible braided operad is formed by a collection of contractible classifying

spaces EB_r naturally associated to the braid groups B_r . In a preliminary stage, we review the general definition of these contractible classifying spaces EG , which can be associated to any group G .

5.2.13. *Translation categories and their classifying spaces.* First, to a group G , we associate a translation category E_G which has $\text{Ob } E_G = G$ as object set, and of which morphism sets are reduced to a single element $\text{Mor}_{E_G}(\alpha, \beta) = \{\beta^{-1}\alpha\}$, for all $\alpha, \beta \in G$. This element $\beta^{-1}\alpha$ represents the right translation connecting β and α in G . This interpretation motivates the name of translation category assigned to E_G . The translation category E_G obviously forms a groupoid, for any group G .

The translation category E_G is also naturally equipped with a left G -action, which assigns a functor $g_* : E_G \rightarrow E_G$ to each $g \in G$. This functor is given by the left translation operation $g_*(\alpha) = g\alpha$ at the object level, and by the identity of the translation elements $(g\beta)^{-1}(g\alpha) = \beta^{-1}\alpha$ at the morphism level.

The classifying space associated to the translation category E_G is usually denoted by $EG = \mathbb{B}(E_G)$. By definition of E_G , the n -simplices of this classifying space have a representation of the form

$$\underline{\alpha} = \{\alpha_0 \xrightarrow{\alpha_1^{-1}\alpha_0} \alpha_1 \xrightarrow{\alpha_2^{-1}\alpha_1} \dots \xrightarrow{\alpha_n^{-1}\alpha_{n-1}} \alpha_n\},$$

where $(\alpha_0, \dots, \alpha_n)$ runs over G^{n+1} . The morphisms occurring in this simplex are determined by the sequence of vertices $(\alpha_0, \dots, \alpha_n)$, as we see in the above expression. Faces d_i (respectively, degeneracies s_j) are given by the omission (respectively, repetition) of a vertex α_i (respectively, α_j). By functoriality of the classifying space construction, the simplicial set EG inherits a left G -action from the translation category E_G . The image of a simplex $\underline{\alpha}$ under this action reads:

$$g_*(\underline{\alpha}) = \{g\alpha_0 \xrightarrow{(g\alpha_1)^{-1}(g\alpha_0)} g\alpha_1 \xrightarrow{(g\alpha_2)^{-1}(g\alpha_1)} \dots \xrightarrow{(g\alpha_n)^{-1}(g\alpha_{n-1})} g\alpha_n\}.$$

The space EG is equipped with a natural map $p_* : EG \rightarrow BG$ towards the classifying space of the group G . If we regard the group G as a category with a single object $*$, then this classifying space map is induced by the functor $p : E_G \rightarrow G$ defined by $p(\alpha) = *$ on objects and by $p(\beta^{-1}\alpha) = \beta^{-1}\alpha$ on morphisms. The motivations for the introduction of this space EG are given by the following observations:

OBSERVATION 5.2.14.

- (a) *The groupoid E_G is equivalent to a point, and as a consequence, has a contractible classifying space $EG = \mathbb{B}(E_G)$.*
- (b) *The action of G on EG is free.*
- (c) *The mapping $p_* : EG \rightarrow BG$ goes down to an isomorphism $EG/G \xrightarrow{\cong} BG$ on the quotient space EG/G .*

These observations follow from immediate inspections. In the topological context, the contractibility of the simplicial set EG implies that the space $|EG|$ is contractible. The free action of G on EG gives rise to a free and proper action at the topological level. Furthermore, the mapping $p_* : EG \rightarrow BG$ induces a homeomorphism $|EG|/G = |EG/G| \xrightarrow{\cong} |BG|$ since we have $|X/G| = |X|/G$ for any space X equipped with a G -action.

We now consider the translation categories E_{B_r} associated to the braid groups B_r . We immediately see that the collection formed by this sequence of groupoids

$E(r) = E_{B_r}$ inherits a natural braided operad structure from the braid groups: the natural action of the group B_r on each E_{B_r} gives the braided structure of the collection E ; the identity $E_{B_1} = pt$ provides the operadic unit $\eta : pt \rightarrow E(1)$; and the composition morphism is the functor $\circ_k : E_{B_m} \times E_{B_n} \rightarrow E_{B_{m+n-1}}$ determined by the operadic composition of braids at the level of the object sets $\text{Ob } E_{B_n} = B_n$. We also easily check, by using the result obtained at the level of braid groups, that these morphisms fulfill the structure axioms of braided operads.

We apply the symmetrization functor of Proposition 5.1.5 in the context of the category of categories $\mathcal{M} = \mathcal{C}at$ in order to get a symmetric operad $\text{Sym } E$ naturally associated to E . We have the following observation:

LEMMA 5.2.15. *The colored braid operad CoB is identified, as a symmetric operad in groupoids, with the symmetrization of the braided operad E defined by the translation categories $E(r) = E_{B_r}$ of the braid groups B_r .*

PROOF. We use the definition of §5.2.9 where we identify the morphism sets of the groupoid $\text{CoB}(r)$ with the cosets $\text{Mor}_{\text{CoB}(r)}(u, v) = q_*^{-1}(v^{-1}u)$ naturally associated to the morphism $q_* : B_r \rightarrow \Sigma_r$. We have an obvious functor $q_* : E_{B_r} \rightarrow \text{CoB}(r)$, given by the map $q_* : B_r \rightarrow \Sigma_r$ on the object set $\text{Ob } E_{B_r} = B_r$, and by the embedding $\{\beta^{-1}\alpha\} \hookrightarrow q_*^{-1}(q_*(\beta)^{-1}q_*(\alpha))$ on each morphism set $\text{Mor}_{E_{B_r}}(\alpha, \beta) = \{\beta^{-1}\alpha\}$, for $\alpha, \beta \in B_r$. We immediately see that this functor carries the action of B_r on E_{B_r} to the natural action of Σ_r on $\text{CoB}(r)$, the action of $P_r \subset B_r$ to a trivial action. We can also readily check, by unraveling the definition of a quotient object in the category of categories, that $q_* : E_{B_r} \rightarrow \text{CoB}(r)$ identifies $\text{CoB}(r)$ with the quotient category E_{B_r}/P_r .

We have already observed that $q_* : E_{B_r} \rightarrow \text{CoB}(r)$ carries the B_r -action on E_{B_r} to the natural Σ_r -action on the groupoid $\text{CoB}(r)$. We readily obtain that q_* preserves the operadic composition structures too by using the coset definition of this structure in §5.2.11. Accordingly, the collection of functors $q_* : E_{B_r} \rightarrow \text{CoB}(r)$ defines a morphism $q_* : E \rightarrow \text{CoB}$ in the category of braided operads, and the relation $E_{B_r}/P_r = \text{CoB}(r)$ immediately implies that this morphism identifies CoB with the symmetric operad naturally associated to E . \square

The conclusion of Proposition 5.2.5 remains obviously valid in the context of braided operads. In the particular case of the translation categories associated to braid groups $E(r) = E_{B_r}$, we deduce from this assertion that:

FACT 5.2.16. *The collection of classifying spaces $\mathbb{B} E(r) = \mathbb{B}(E_{B_r}) = EB_r$ inherits a braided operad structure.*

The geometric realization and classifying space functors naturally commute with quotients under group actions. In the case of the symmetrization functor Sym , which is essentially given by such a quotient process, this observation implies:

OBSERVATION 5.2.17. *We have operad identities $\text{Sym} |\mathbb{B} E| = |\text{Sym } \mathbb{B} E| = |\mathbb{B}(\text{Sym } E)|$.*

Thus, from the identity $\text{Sym } E = \text{CoB}$ established in Lemma 5.2.15, we conclude that $|\mathbb{B}(\text{CoB})|$ is identified with the symmetrization of the contractible braided operad $|\mathbb{B} E|$. The braided operad $\mathbb{B} E$ is also contractible by observation 5.2.14 and the braid group B_r operates freely and properly at the level of the topological space $|\mathbb{B} E(r)| = EB_r$. By Theorem 5.1.14, these assertions imply that $|\mathbb{B}(\text{CoB})| = \text{Sym} |\mathbb{B} E|$ forms an E_2 -operad, as claimed in Theorem 5.2.12. \square

5.2.18. *Remark.* The category of algebras associated with the colored braid operad consists of braided categories equipped with a strictly associative tensor product. This statement is an operadic counterpart of a result of Joyal and Street [93] asserting that the disjoint union of the braids groups form a free braided category on one generating object. The correspondence between operads in groupoids and monoidal structures on categories is the subject of the next chapter, and we go back to the connection between the colored braid operad and Joyal-Street' statement in this subsequent account.

5.3. Fundamental groupoids and operads

In the previous section, we observed that the identity between the Eilenberg space $D_2(r)$ and an Eilenberg-MacLane spaces $K(P_r, 1)$ determines the homotopy type of the spaces underlying the little discs operad D_2 . However, we have needed to replace the pure braid groups P_r by groupoids of colored braids $\mathbf{CoB}(r)$ in order to retrieve an operad reflecting the structure associated with the little 2-discs operad.

The purpose of this section is to explain the source of our problems and to give an explanation for the introduction of colored braids in §5.2.

The pure braid group P_r represents the fundamental group of the little 2-discs space $D_2(r)$, and involves, by definition of the fundamental group, the choice of a base point in $D_2(r)$. The problem comes from this choice: base points can not be chosen coherently with respect to the structure operations attached to an operad. The natural idea is to replace fundamental groups by fundamental groupoids in order to work out this issue. In the case of the little 2-discs operad D_2 , we prove precisely that the fundamental groupoids of the spaces $D_2(r)$ form an operad in groupoids which is equivalent to the colored braid operad of §5.2. The main purpose of this section is to establish this result. Before, we quickly recall the definition of the fundamental groupoid and we check that the fundamental groupoids of the spaces underlying an operad in topological spaces form an operad in groupoids.

5.3.1. *Fundamental groupoids.* The fundamental groupoid of a topological space is denoted by πX . The object set of this groupoid πX is the underlying point-set of the space X . Let $x, y \in X$. The morphisms from x to y in πX are the homotopy classes of paths $\alpha : [0, 1] \rightarrow X$ with $\alpha(0) = x$ as prescribed origin and $\alpha(1) = y$ as prescribed endpoint. The composition of morphisms in πX is given by the usual composition operation on paths, and extends the composition of based loops considered in the definition of the fundamental group. The unit relation, the associativity relation and the existence of inverses in πX is proved by a straightforward extension of the arguments classically considered in the context of fundamental groups.

The fundamental group of X at a base point $x_0 \in X$ is clearly identified with the automorphism set of x_0 in the fundamental groupoid

$$\pi_1(X, x_0) = \mathbf{Mor}_{\pi X}(x_0, x_0)$$

and we have an isomorphism connecting $x_0 \in X$ to another point $x \in X$ in πX if and only if x_0 and x belongs to the same path connected component of X .

Thus, if we regard a group as a groupoid with one object, then we can also identify the fundamental group $\pi_1(X, x_0)$ at a base point x_0 with the full subcategory of πX generated by the single object $\{x_0\} \subset X = \mathbf{Ob} \pi X$, and, when X is path connected, the embedding $\pi_1(X, x_0) \hookrightarrow \pi X$, which arises from this categorical interpretation of the fundamental group, defines an equivalence of categories.

In general, the fundamental groupoid is equivalent (as a category) to the coproduct $\coprod_{[x_0] \in \pi_0(X)} \pi_1(X, x_0)$ formed by picking a representative $x_0 \in C$ in each path connected component $[x_0] = C \in \pi_0(X)$ of the space X .

Even in the path connected case, we usually have no canonical choice for a single base point x_0 in X . In subsequent applications, we rather consider subsets $A \subset X$ and the full subcategories, denoted by $\pi X \upharpoonright_A$, which such subsets generate. The embedding $\pi X \upharpoonright_A \hookrightarrow \pi X$ defines an equivalence of groupoids as soon as A includes a representative of each path connected component of X .

The mapping $\pi : X \mapsto \pi X$ clearly gives a functor from spaces to groupoids, and usual results on fundamental groups extend to fundamental groupoids. But, in the groupoid context, we need to take care of the difference between the notion of isomorphism and the notion of equivalence. For instance, a homeomorphism induces an isomorphism on fundamental groupoids, but a homotopy equivalence $f : X \xrightarrow{\sim} Y$ induces a groupoid equivalence $f_* : \pi X \xrightarrow{\sim} \pi Y$, and no more, unless f is a bijection at the point set level.

In order to study the image of topological operads under the fundamental groupoid functor $\pi : \mathcal{Top} \rightarrow \mathcal{Grd}$, we establish as usual that:

PROPOSITION 5.3.2. *The functor $\pi : \mathcal{Top} \rightarrow \mathcal{Grd}$ is symmetric monoidal:*

- (a) *for a point pt , viewed as the unit object of the category of spaces, we have an obvious identity $\pi pt = pt$;*
- (b) *for a cartesian product of spaces $X \times Y$, the maps $\pi X \xleftarrow{p_*} \pi(X \times Y) \xrightarrow{q_*} \pi Y$, induced by the canonical projections $X \xleftarrow{p} X \times Y \xrightarrow{q} Y$, give rise to an isomorphism $\pi(X \times Y) \xrightarrow{\cong} \pi X \times \pi Y$;*
- (c) *and these comparison isomorphisms (a-b) fulfill the unit, associativity and symmetry constraints of §2.3.1.*

PROOF. The proof of assertion (a) is immediate. The proof of assertion (b) reduces to a straightforward extension of arguments classically used in the case of fundamental groups. The definition of the isomorphism $\pi(X \times Y) \xrightarrow{\cong} \pi X \times \pi Y$ from universal categorical constructions automatically ensures, as usual, that the unit, associativity and symmetry constraints of symmetric monoidal functors are fulfilled. \square

From this statement, the result of Proposition 2.1.4 gives:

PROPOSITION 5.3.3. *Let P be an operad in topological spaces. The collection of groupoids $\pi P(r)$ associated to the spaces $P(r)$ forms an operad in groupoids naturally associated to P .* \square

From Proposition 2.1.4, we also deduce that the mapping $\pi : P \mapsto \pi P$ preserves unitary extensions, or more explicitly, that we have an identity $\pi(P_+) = (\pi P)_+$, for any unitary operad in topological spaces P_+ .

Now, for the operad of little 2-discs, we obtain the following result:

THEOREM 5.3.4. *The fundamental groupoid operad of the little 2-discs operad πD_2 is related to the colored braid operad CoB of §5.2 by a chain of categorical equivalences of operads in groupoids*

$$\pi D_2 \xleftarrow{\sim} \cdot \xrightarrow{\sim} \text{CoB},$$

and similarly for the unitary extension of these operads πD_{2+} and CoB_+ .

PROOF. We use the embedding $D_1 \hookrightarrow D_2$, defined in §4.1.5, to identify the operad of little 1-discs D_1 with a suboperad of D_2 . We consider, for each $r \in \mathbb{N}$, the full subcategory of the fundamental groupoid $\pi D_2(r)$ generated by the image of the set $D_1(r)$ in $D_2(r)$. We adopt the notation $\pi D_2(r) \upharpoonright_{D_1(r)}$ for this category, which obviously forms a groupoid. The collection of groupoids

$$\pi D_2 \upharpoonright_{D_1} = \{\pi D_2(r) \upharpoonright_{D_1(r)}\}_{r \in \mathbb{N}}$$

also defines a suboperad of πD_2 because the object sets $D_1(r)$ associated to these groupoids $\pi D_2(r) \upharpoonright_{D_1(r)}$ form themselves a suboperad of the little 2-discs operad D_2 , regarded as an operad in sets. We use this operad $\pi D_2 \upharpoonright_{D_1} \subset \pi D_2$ as an intermediate object between the fundamental groupoid operad πD_2 and the colored braid operad CoB .

The embeddings $\pi D_2(r) \upharpoonright_{D_1(r)} \hookrightarrow \pi D_2(r)$ are equivalences of categories since each space $D_2(r)$ is connected, and as a consequence, the embedding of operads in groupoids $\pi D_2 \upharpoonright_{D_1} \hookrightarrow \pi D_2$ defined by the collection of these morphisms forms a categorical equivalence of operads. To complete our arguments, we define a second categorical equivalence of operads $\pi D_2 \upharpoonright_{D_1} \xrightarrow{\sim} CoB$ connecting $\pi D_2 \upharpoonright_{D_1}$ with the colored braid operad CoB . In a preliminary step, we construct the collection of groupoid equivalences $\pi D_2(r) \upharpoonright_{D_1(r)} \xrightarrow{\sim} CoB(r)$ underlying our operad morphism.

Let $\Pi(r)$ be the subset of the configuration space $F(\mathbb{D}^2, r)$ formed by the elements of the form $\underline{a}_w^0 = ((x_{w(1)}^0, 0), \dots, (x_{w(r)}^0, 0))$, where $w \in \Sigma_r$. If we go back to the construction of §5.2.8, where we define the groupoids of colored braids, then we immediately see that the isotopy classes of braids defining the morphisms of the colored operad are nothing but homotopy classes of paths between elements of $\Pi(r)$. In other words, we have a formal identity $CoB(r) = \pi F(\mathbb{D}^2, r) \upharpoonright_{\Pi(r)}$, for each $r \in \mathbb{N}$.

The homotopy equivalence $\omega : D_2(r) \xrightarrow{\sim} F(\mathbb{D}^2, r)$, defined by the disc center mapping (see §§4.2.1-4.2.2), induces an equivalence of fundamental groupoids $\omega_* : \pi D_2(r) \xrightarrow{\sim} \pi F(\mathbb{D}^2, r)$. In order to connect $\pi D_2(r) \upharpoonright_{D_1(r)} \subset \pi D_2(r)$ with the groupoid $CoB(r) = \pi F(\mathbb{D}^2, r) \upharpoonright_{\Pi(r)}$, we pick a collection of little 2-discs \underline{c}^0 in the image of our embedding $D_1(r) \rightarrow D_2(r)$ so that $\omega(\underline{c}^0) = \underline{a}_{id}^0$. Then we consider the subset $\Xi(r)$ formed by the elements $\underline{c}_w^0 = w_*(\underline{c}^0)$, $w \in \Sigma_r$, in $D_1(r) \hookrightarrow D_2(r)$. The disc center mapping is clearly equivariant, so that $\omega(\underline{c}_w^0) = \underline{a}_w^0$, for all $w \in \Sigma_r$, and the equivalence $\omega_* : \pi D_2(r) \xrightarrow{\sim} \pi F(\mathbb{D}^2, r)$ induces, by restriction to $\Xi(r) \subset D_2(r)$, a groupoid isomorphism $\pi D_2(r) \upharpoonright_{\Xi(r)} \xrightarrow{\cong} \pi F(\mathbb{D}^2, r) \upharpoonright_{\Pi(r)}$. To recap, we now have a groupoid diagram

$$(a) \quad \begin{array}{ccc} \pi D_2(r) \upharpoonright_{\Xi(r)} & \xrightarrow{\cong} & \pi F(\mathbb{D}^2, r) \upharpoonright_{\Pi(r)} & \xrightarrow{=} & CoB(r) \\ \downarrow & & \downarrow & & \\ \pi D_2(r) \upharpoonright_{D_1(r)} & & & & \\ \downarrow & & \downarrow & & \\ \pi D_2(r) & \xrightarrow{\sim} & \pi F(\mathbb{D}^2, r) & & \end{array}$$

where vertical morphisms are embeddings of full subgroupoids, the bottom horizontal morphism is a groupoid equivalence, and the upper horizontal morphism is a groupoid isomorphism. The connectedness of $D_2(r)$ implies that the first vertical

embedding $\pi D_2(r) \upharpoonright_{\Xi(r)} \hookrightarrow \pi D_2(r) \upharpoonright_{D_1(r)}$ defines an equivalence of groupoids too, just like the second embedding $\pi D_2(r) \upharpoonright_{D_1(r)} \hookrightarrow \pi D_2(r)$.

The groupoid equivalence which we aim to define is obtained by picking an appropriate inverse equivalence of the embedding $\pi D_2(r) \upharpoonright_{\Xi(r)} \hookrightarrow \pi D_2(r) \upharpoonright_{D_1(r)}$.

Recall that the embedding of a configuration of little 1-discs $\underline{c} = (c_1, \dots, c_r)$ in the interval $\mathbb{D}^1 = [-1, 1]$ determines a linear ordering $i_1 < \dots < i_r$ of the indices of these 1-discs c_i . In Proposition 4.1.6, we use this observation to assign a permutation $w = (i_1, \dots, i_r)$ to each element $\underline{c} \in D_1(r)$, and to establish the identity $\pi_0 D_1(r) = \Sigma_r$. To an element \underline{c} in the image of $D_1(r) \hookrightarrow D_2(r)$, we associate the element $\underline{c}_w^0 \in \Xi(r)$, formed by applying the permutation w associated to \underline{c} to the initially chosen configuration of little 2-discs \underline{c}^0 . This construction amounts to considering the element \underline{c}_w^0 lying in the same connected component $D_1(r)_w$ of the 1-disc space $D_1(r)$ as our configuration \underline{c} within $D_2(r)$.

Recall that each space $D_1(r)_w$ is contractible. We pick a path γ connecting the element $\gamma(0) = \underline{c}_w^0$ to $\gamma(1) = \underline{c}$ and lying in this contractible space. We perform such a choice of path for every element \underline{c} in the image of the little 1-disc space $D_1(r)$ in $D_2(r)$. The homotopy class of our path γ represents an isomorphism between \underline{c} and \underline{c}_w^0 in the fundamental groupoid $\pi D_2(r)$. We consider the groupoid morphism $\pi D_2(r) \upharpoonright_{D_1(r)} \rightarrow \pi D_2(r) \upharpoonright_{\Xi(r)}$ which maps each object \underline{c} to the associated configuration \underline{c}_w^0 in the set $\Xi(r)$, and which is given, at the morphism set level, by the composition with the isomorphism $[\gamma] \in \text{Mor}_{\pi D_2(r)}(\underline{c}_w^0, \underline{c})$ determined by the homotopy class of our path connecting \underline{c}_w^0 and \underline{c} within $D_1(r) \hookrightarrow D_2(r)$. The contractibility of the space $D_1(r)_w$, where we define this path γ , implies that this isomorphism does not depend on choices.

Now we can take the composite of the just defined equivalence of groupoids with the obvious isomorphism $\pi D_2(r) \upharpoonright_{\Xi(r)} \xrightarrow{\sim} \pi F(\mathbb{D}^2, r) \upharpoonright_{\Pi(r)}$ in order to get a morphism of groupoids

$$(b) \quad \pi D_2(r) \upharpoonright_{D_1(r)} \xrightarrow{\sim} \pi F(\mathbb{D}^2, r) \upharpoonright_{\Pi(r)} = \text{CoB}(r),$$

which is also an equivalence by construction. We see that our mapping which associates an element \underline{c}_w^0 to any \underline{c} is equivariant with respect to the action of permutation, and as a consequence, so is our groupoid morphism since we observed that our construction does not depend on any other choice.

We immediately see that our morphism sends the unit element of the operad $\pi D_2 \upharpoonright_{D_1}$ to the unit element of the colored braid operad CoB too because we trivially have $\text{CoB}(1) = \pi F(\mathbb{D}^2, 1) \upharpoonright_{\Pi(1)} = pt$. We also see that our groupoid morphisms commute with operadic composition structures at the object level, because we use the decomposition of the little 1-discs operad into connected components to determine our correspondence on objects, and the operadic composition of permutations reflects the operadic composition associated to the connected components of the little 1-discs operad. The existence of a groupoid equivalence between $\pi D_2(r) \upharpoonright_{D_1(r)}$ and $\text{CoB}(r)$ for each r implies that the morphisms of the groupoid $\pi D_2(r) \upharpoonright_{D_1(r)}$ are composites of paths representing the generating braids τ_i in the little 2-discs space $D_2(r)$. We easily see, by going back to our figures, that we retrieve the definition of the operadic composites of generating and identity braids in Proposition 5.1.2 when we form operadic composites of paths in the little 2-discs operads corresponding to these generating elements of the braid group (see

Figure 5.12). We deduce from this generating case that our groupoid morphisms preserve the operadic composition of all morphisms in our groupoids.

We conclude that our collection of groupoid equivalences (b) defines a morphism of operads in groupoids $\pi D_2 \mid_{D_1} \rightarrow CoB$, which is also a categorical equivalence by construction. Hence, we finally have a chain of categorical equivalences of operads in groupoids

$$(c) \quad \pi D_2 \xleftarrow{\sim} \pi D_2 \mid_{D_1} \xrightarrow{\sim} CoB$$

connecting the fundamental groupoid of the operad of little 2-discs πD_2 to the operad of colored braids CoB . We also readily see, by an immediate extension of our arguments, that these categorical equivalences preserve the restriction operations attached to our operads, and hence, extends to categorical equivalences of unitary operads. This observation completes the proof of Theorem 5.3.4. \square

5.3.5. *Remark: The representation of morphisms in the fundamental groupoid of the little 2-discs operad.* The bijection

$$\omega_* : \text{Mor}_{\pi D_2(r)}(\underline{a}, \underline{b}) \xrightarrow{\cong} \text{Mor}_{\pi F(\hat{\mathbb{D}}^2, r)}(\omega(\underline{a}), \omega(\underline{b}))$$

induced by the disc center mapping $\omega : D_2(r) \xrightarrow{\cong} F(\hat{\mathbb{D}}^2, r)$ implies that the morphisms of the fundamental groupoid of the little 2-discs space are specified by:

- a configuration of little 2-discs $\underline{a} = (a_1, \dots, a_r)$, which represents the source of our morphism,
- a configuration of little 2-discs $\underline{b} = (b_1, \dots, b_r)$, which defines the target,
- and a braid on r strands $\alpha = (\alpha_1, \dots, \alpha_r)$ so that α_i connects the center of the i th little 2-disc a_i in the source configuration \underline{a} to the center of the i th little 2-disc b_i in the target configuration \underline{b} .

Thus, we get a picture of the following form:

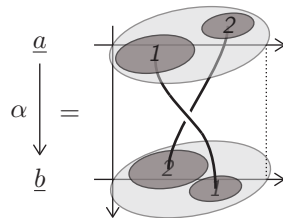

for a morphism $\alpha \in \text{Mor}_{\pi D_2(2)}(\underline{a}, \underline{b})$, with the configuration of little 2-discs \underline{a} represented at the top of the picture, and \underline{b} at the bottom.

In the special case of configurations of little 2-discs centered on the axis $y = 0$, like

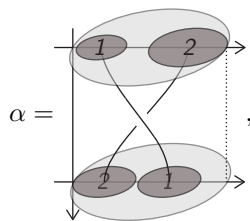

we may use a simplified picture where, as in the braid diagram representation, we only retain the trace of our little 2-discs configurations on the axis $y = 0$:

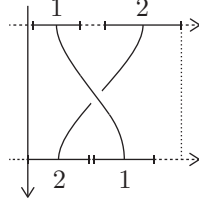

This trace also represents the counter-image of our configurations of little 2-discs under the operad embedding $D_1 \hookrightarrow D_2$. The groupoid equivalence $\pi D_2(r) \downarrow_{D_1(r)} \xrightarrow{\sim} CoB(r)$, considered in the proof of Theorem 5.3.4, is given at the morphism level by a simple path concatenation operation which recenters the contact points of such braid diagrams.

5.3.6. *Extra remarks.* The results of Theorem 5.2.12 and Theorem 5.3.4 are actually not independent though we give a direct proof of each statement. To explain the precise relationship between our results, we move from topological spaces to simplicial objects.

The classifying space construction of §5.2.3 is naturally given as a functor from categories to simplicial sets. The fundamental groupoid construction has a combinatorial analogue, defined on the category of simplicial sets, and yielding a left adjoint $\pi : Simp \rightarrow Grd$ of the restriction of the classifying space functor $B : Cat \rightarrow Simp$ to the category of groupoids $Grd \subset Cat$. The augmentation $\pi B\mathcal{G} \rightarrow \mathcal{G}$ of this adjunction $\pi : Simp \rightleftarrows Grd : B$ defines an isomorphism of groupoids, for all $\mathcal{G} \in Grd$. The adjunction unit $X \rightarrow B\pi X$ defines a weak-equivalence of simplicial sets when X is a Kan complex with a trivial homotopy in degree $* > 1$.

The simplicial version of the fundamental groupoid $\pi : Simp \rightarrow Grd$ is a symmetric monoidal functor, like the topological one (this result is a variation on the Eilenberg-Zilber correspondence). Therefore, the fundamental groupoid induces a functor $\pi : SimpOp \rightarrow GrdOp$ from simplicial operads to operads in groupoids, which is still left adjoint of the functor $B : GrdOp \rightarrow SimpOp$ defined by the arity-wise application of the classifying space functor from groupoids to simplicial sets. By combining this adjunction with the realization and singular complex adjunction relation (see §2.1.7), we get a chain of adjunctions

$$\begin{array}{ccccc}
 TopOp & \xleftarrow{|-|} & SimpOp & \xrightarrow{\pi} & GrdOp \\
 & \xrightarrow{(1)} & & \xleftarrow{(2)} & \\
 & \xrightarrow{Sing_\bullet(-)} & & \xleftarrow{B} &
 \end{array}$$

connecting the category of topological operads and the category of operads in groupoids.

The unit (respectively, the augmentation) of the adjunction between simplicial sets and topological spaces is a weak-equivalence, and so is the unit (respectively, the augmentation) of the corresponding adjunction (1) on operad categories.

The augmentation of the adjunction between simplicial sets and groupoids defines a groupoid isomorphism $\pi B\mathcal{G} \xrightarrow{\sim} \mathcal{G}$, for all $\mathcal{G} \in Grd$, while the unit of this adjunction $X \rightarrow B\pi X$ defines a weak-equivalence of simplicial sets as soon as X is a Kan complex with a trivial homotopy in degree $* > 1$. These assertions extend to the unit and the augmentation of the induced adjunction (2) on operad categories.

From these observations, we deduce that the existence of weak-equivalences of operads $D_2 \xleftarrow{\sim} \cdot \xrightarrow{\sim} \mathbf{B} \mathit{CoB}$, asserted by Theorem 5.2.12, implies the existence of categorical equivalences of groupoids connecting πD_2 and $\pi \mathbf{B} \mathit{CoB} \xrightarrow{\sim} \mathit{CoB}$. On the other hand, since we observed that the underlying spaces of the little 2-discs operad D_2 are Eilenberg-MacLane spaces, we automatically have weak-equivalences of operads connecting D_2 and $\mathbf{B} \pi D_2$. Hence, the existence of equivalences of operads in groupoids between πD_2 and CoB , asserted by Theorem 5.3.4, also implies the existence of weak-equivalences of simplicial operads connecting D_2 and $\mathbf{B} \mathit{CoB}$, which we establish in Theorem 5.2.12.

Our adjunctions (1-2) can also be used to give a necessary and sufficient recognition criterion of E_2 -operads. Namely, an operad P is E_2 if and only if each space $P(r)$ has a trivial homotopy in degree $* > 1$ and πP is equivalent to the colored braid operad CoB as an operad in groupoids.

5.4. Outlook: The recognition of E_n -operads for $n > 2$

The recognition of E_n -operads is more difficult in the case $n > 2$ than in the case $n = 2$, because the underlying spaces of the little n -discs operads are no longer Eilenberg-MacLane spaces when $n > 2$. On the other hand, we do have sufficient conditions asserting, as in Theorem 5.1.14, that certain operads $\mathit{Sym}_n P$ obtained by a quotient process from an appropriate contractible object P are E_n .

In the context of Theorem 5.1.14, we consider the category of braided operads, the obvious restriction functor from symmetric operads to braided operads, and the symmetrization functor which represents a left adjoint of this one. Nice analogues of these notions have been introduced by Michael Batanin's with the aim of defining higher dimensional generalizations of fundamental groupoids (see [15] for this part of the program). In Batanin's approach [17, 16, 18], the category of braided operads is replaced by a category of n -operads, which have an underlying collection $P(\tau)$ indexed by n -level trees, representing certain composition patterns that can be formed from the structure of an n -category. We again have an obvious functor $\mathcal{O}p \rightarrow {}_n \mathcal{O}p$, from the category of ordinary operads to the category of n -operads, and we consider an n -symmetrization functor in the converse direction $\mathit{Sym}_n : {}_n \mathcal{O}p \rightarrow \mathcal{O}p$. In [16], Batanin establishes that the symmetrization of a contractible n -operad (satisfying some suitable cofibrancy requirement) is an E_n -operad. In [17], he proves further that many usual models of E_n -operads, like the Fulton-MacPherson operads (see §4.3), can be obtained as instances of this symmetrization construction.

Batanin's recognition criteria are used to define models of E_n -operads, for each n independently. In [20], Clemens Berger explains that models of the little n -discs operads, regarded as a nested sequence of operads, can be obtained from contractible (symmetric) operads equipped with an appropriate cell structure. The first application of this recognition method, given by Berger himself in [20], is the construction of simplicial models of E_n -operads from a basic simplicial operad, first considered by Barratt-Eccles in [14], and given by an application of the translation category construction of §§5.2.13-5.2.16 to the symmetric groups Σ_n . The E_n -operads arising from the Barratt-Eccles operad are related to simplicial models of n -fold spaces of suspensions $\Omega^n \Sigma^n X$ (defined by Jeff Smith in [160]). Berger's method has also been applied successfully by Jim McClure and Jeff Smith in [136] to prove that a certain operad, defined by natural operations acting on Hochschild cochain complexes, is E_2 . This result has led to a new conceptual

proof of the Deligne conjecture claiming the existence of a natural E_2 -structure on the Hochschild cochain complex (see the preface of the book).

Other models of E_n -operads, related to the topics studied in the present chapter, arise from the iterated monoidal categories of [12], which generalize the classical braided monoidal categories of quantum algebra ($n = 2$) and yield higher intermediate structures between the standard (noncommutative) monoidal categories ($n = 1$) and symmetric monoidal categories ($n = \infty$).

The Magma and Parenthesized Braid Operad

The operads in the category of small categories, like the operad of colored braids considered in the previous chapter, govern multiplicative structures associated to categories. In §5.2.18, we already mentioned that an action of the operad of colored braids on a category encodes a braided monoidal structure whose tensor product is associative in the strict sense. We give a detailed proof of this statement in this chapter. But our main purpose is to explain the definition of a variant of the operad of colored braids, the operad of parenthesized braids, whose actions encode general braided monoidal structures, where the tensor product is associative up to a natural isomorphism.

Recall that the colored braid operad is an operad in groupoids CoB of which object sets form an operad in sets isomorphic to the permutation operad Π . The morphisms of the r th component of this operad $CoB(r)$ are isotopy classes of braids with r strands whose (fixed) contact points are labeled by indices (i_1, \dots, i_r) (the colors) that form a permutation of the set $(1, \dots, r)$. These contact points, together with the associated colors, represent the objects of our operad. In the parenthesized braid operad, denoted by PaB , the object sets form an operad in sets isomorphic to a free operad $\Omega = \mathcal{O}(\mu(x_1, x_2), \mu(x_2, x_1))$ generated by a non-symmetric operation $\mu = \mu(x_1, x_2)$ in arity 2. We adopt the name magma, which Bourbaki introduces for general non-associative structures (see [31, §I.1]), to refer to this free operad in sets.

In our geometrical picture, the morphisms of the r th component of the parenthesized braid operad $PaB(r)$ are still defined by isotopy classes of braids with r strands, but we now consider contact points located on the center of diadic partitions of the interval $[-1, 1]$. These diadic partitions are in bijection with planar binary trees and this correspondence gives the iso between the object sets of the parenthesized braid operad and the terms of the magma operad.

The diadic partitions correspond to a suboperad of the little 2-disc operad defined by certain little 2-disc configurations centered on the horizontal axis. The components of the operad of parenthesized braids are actually identified with the full subgroupoids of the fundamental groupoid operad of little 2-discs defined by these particular subsets of base points. Recall that the connection between the colored braid operad CoB and the fundamental operad of little 2-discs πD_2 involves a chain of categorical equivalences $\pi D_2 \xleftarrow{\sim} \cdot \xrightarrow{\sim} CoB$. The operad of parenthesized braids PaB is actually the minimal object which can be used to give the middle term in such a chain.

In a preliminary step §6.1, we explain the definition, from the magma operad, of an operad governing general monoidal category structures, where we have no symmetry constraint on the tensor product. By the way, we also give an operadic interpretation of the Mac Lane Coherence Theorem. In a second step §6.2, we

address the definition of the parenthesized braid operad itself, and we give the proof that this operad is associated to general braided monoidal category structures.

Let us mention that D. Bar-Natan uses the expression of parenthesized braid and the notation PaB_r for a structure which is not our parenthesized braid operad (see [13]). Bar-Natan's parenthesized braid categories actually represent, in a linear context, the summands of a free braided monoidal category on one generating object. The same difference of conception occurs for the parenthesized permutation operad PaP which we consider in §6.1. We explain the connection between Bar-Natan formalism and our operadic approach with more details in §6.2.8. By the way, we also explain the relationship between the operad of colored braids of §5.2 and Joyal-Street' definition of the free braided monoidal category on one generating object.

6.1. Magmas and the parenthesized permutation operad

The ultimate objective of this chapter, as we just explained, is to define an operad in groupoids, the operad of parenthesized braids, with the same morphism sets as the operad of colored braids in §5.2, but where the object sets are changed to terms of the magma operad in order to encode general braided monoidal category structures. The rough idea is to perform a pull-back operation in order to perform this change of object sets. This pull-back process can also be used to get an operad governing general non-symmetric monoidal categories, and we study this more basic example in a first instance in this section. The relationship between monoidal structures and our pull-back of operads in groupoids actually follows on an operadic formulation of the Mac Lane Coherence Theorem which we explain in this section too.

The magma operad, as we explain in the introduction of this chapter, is a free operad (in sets) with a single (non-symmetric generator) μ in arity 2. We explicitly set:

$$\Omega = \mathbb{O}(\mu(x_1, x_2), \mu(x_2, x_1)),$$

where $\mu = \mu(x_1, x_2)$ denotes our generating operation, and $t\mu = \mu(x_2, x_1)$, with $t = (1\ 2)$, is the associated transposed element. The algebras associated with this operad are identified with Bourbaki's (non-commutative) magmas (see [31, §I.1]). To be explicit, by going back to the definition of free operads in §1.2, we see that an Ω -algebra in sets consists of an object $A \in Set$ equipped with a (possibly non-commutative and non-associative) product $m : A \times A \rightarrow A$, giving the action of the generating operation $\mu \in \Omega(2)$ on A . This is exactly Bourbaki's definition of a magma, and the name of the magma operad is motivated by this correspondence.

To begin this section, we explain a representation of the elements of the magma operad in terms of non-commutative non-associative monomials and planar binary trees.

6.1.1. *The algebraic definition of the magma operad.* Recall that the elements of a free operad intuitively consists of formal operadic composites of generating operations, with no more relation between them as the general equivariance, unit and associativity relations of operads. In the case of the magma operad, we consider operadic composites of the product $\mu = \mu(x_1, x_2)$, and of the transposed operation $t\mu = \mu(x_2, x_1)$. If we take the usual product notation $x_1x_2 = \mu(x_1, x_2)$ for the generating operation $\mu = \mu(x_1, x_2)$, then these operadic composites have the form

of parenthesized words

$$(x_i x_j), \quad ((x_i x_j) x_k), \quad (x_i (x_j x_k)), \\ (((x_i x_j) x_k) x_l), \quad ((x_i (x_j x_k)) x_l), \quad ((x_i x_j) (x_k x_l)), \quad \dots$$

defined by providing any permutation of the variables (x_1, \dots, x_r) with a full binary bracketing (the parenthesization). These parenthesized words are the non-commutative non-associative monomials considered by Bourbaki.

In this algebraic representation of the elements of the magma operad, the symmetric groups act by permuting variable indices, the unit is defined by the one-variable word $1 = 1(x_1) = x_1$, and the operadic composition operation $\circ_k : \Omega(m) \times \Omega(n) \rightarrow \Omega(m + n - 1)$ are defined by the natural substitution of variables in non-commutative non-associative monomials. For instance, we have:

$$((x_3 x_1) x_2) \circ_1 ((x_2 x_1) x_3) = ((x_5 ((x_2 x_1) x_3)) x_4).$$

To get this composite, we replace the variable x_1 (corresponding to our composition index $k = 1$) in the first monomial $p = ((x_3 x_1) x_2)$ by the second monomial $q = ((x_2 x_1) x_3)$, and we use the variable index shift of §1.1.4 to form a new monomial $p \circ_1 q = p(q(x_1, x_2, x_3), x_4, x_5)$ on the variables (x_1, \dots, x_5) .

6.1.2. *The planar binary tree representation.* In our general construction of free operads, the elements are represented by trees whose vertices are labeled by generating operations. In the case of the magma operad, we can form a reduced version of this representation, where the elements of arity r consist of planar binary trees with r ingoing edges indexed by a permutation (i_1, \dots, i_r) of $(1, \dots, r)$ as in the following picture:

$$(x_i x_j) = \begin{array}{c} i \quad j \\ \diagdown \quad \diagup \\ \text{---} \\ | \end{array}, \quad ((x_i x_j) x_k) = \begin{array}{c} i \quad j \quad k \\ \diagdown \quad \diagup \quad / \\ \text{---} \\ | \end{array}, \quad (x_i (x_j x_k)) = \begin{array}{c} i \quad j \quad k \\ \diagdown \quad \diagup \quad / \\ \text{---} \\ | \end{array}, \\ (((x_i x_j) x_k) x_l) = \begin{array}{c} i \quad j \quad k \quad l \\ \diagdown \quad \diagup \quad / \quad \diagup \\ \text{---} \\ | \end{array}, \quad ((x_i (x_j x_k)) x_l) = \begin{array}{c} i \quad j \quad k \quad l \\ \diagdown \quad \diagup \quad / \quad \diagup \\ \text{---} \\ | \end{array}, \\ ((x_i x_j) (x_k x_l)) = \begin{array}{c} i \quad j \quad k \quad l \\ \diagdown \quad \diagup \quad / \quad \diagup \\ \text{---} \\ | \end{array}, \quad \dots$$

In the representation of §II.A, these planar binary trees correspond to tree-wise elements in which all vertices are labeled by the generating operation μ and where no vertex labeled by the transposed operation $t\mu$ occurs. The equivariance relation of §1.1.5 (see also §II.A.2) implies that the tree-wise elements considered in the appendix are, in the case of the magma operad, equivalent to tree-wise elements of this reduced form, and hence, that we can restrict ourselves to such planar binary trees in our construction.

The symmetric action, the operadic unit and the operadic composition operations of the magma operad are given by the same operations as in §II.A.1 for planar binary trees. The symmetric group acts by permutation of the indices attached to the ingoing edges. To obtain the picture of an operadic composite of trees $\underline{\sigma} \circ_k \underline{\tau}$, we plug the second tree $\underline{\tau}$ in the ingoing edge of the tree $\underline{\sigma}$ marked by the index k and we perform the usual shift operation on the input indices of this composite

object. For instance, in the case considered in §6.1.1, we get the following picture:

$$\begin{array}{c} 3 \\ \swarrow \\ \text{---} \\ \searrow \\ 1 \end{array} \begin{array}{c} 2 \\ \swarrow \\ \text{---} \\ \searrow \\ 1 \end{array} \circ_1 \begin{array}{c} 1 \\ \swarrow \\ \text{---} \\ \searrow \\ 2 \end{array} \begin{array}{c} 3 \\ \swarrow \\ \text{---} \\ \searrow \\ 2 \end{array} = \begin{array}{c} 5 \\ \swarrow \\ \text{---} \\ \searrow \\ 2 \end{array} \begin{array}{c} 1 \\ \swarrow \\ \text{---} \\ \searrow \\ 3 \end{array} \begin{array}{c} 4 \\ \swarrow \\ \text{---} \\ \searrow \\ 3 \end{array} .$$

6.1.3. *The underlying permutation and parenthesization of magma elements.*

We readily see that each component of the magma operad $\Omega(r)$ forms a free Σ_r -set. We obtain, to be more precise, that each element $p \in \Omega(r)$ has a unique writing $p = s\pi = \pi(x_{s(1)}, \dots, x_{s(1)})$, such that π arises as a (multiple) composite of the generating operation $\mu = \mu(x_1, x_2)$ (with no occurrence of the transposed operation), and where s is a permutation acting on this monomial $\pi = \pi(x_1, \dots, x_r)$. We refer to the permutation s occurring in this expression $p = s\pi$ as the underlying permutation of the magma element p . We also refer to the composite defining the monomial π as the underlying parenthesization of the word p .

We can easily retrieve the permutation s and the composite π from the monomial expression of our element $p \in \Omega(r)$. Indeed, the permutation s represents the ordering of the variables in the word underlying p (where we forget about the parenthesization), while the monomial $\pi = \pi(x_1, \dots, x_r)$ is determined by the parenthesization itself (with the variables put in the canonical order). As an example, in the case $p = ((x_5((x_2x_1)x_3))x_4)$, we obtain the permutation $s = (5, 2, 1, 3, 4)$, corresponding to the ordering of variables $x_5x_2x_1x_3x_4$, and we have an identity $p = s\pi = \pi(x_5, x_2, x_1, x_3, x_4)$, where

$$\pi = ((x_1((x_2x_3)x_4))x_5) = \begin{array}{c} 1 \quad 2 \quad 3 \quad 4 \quad 5 \\ \swarrow \quad \swarrow \quad \swarrow \quad \swarrow \\ \text{---} \\ \searrow \\ 1 \end{array} .$$

In the tree-wise representation, the permutation s can also be determined by the ordering (in the plane) of the indices attached to the ingoing edges of our tree, where we use the outgoing edge of the tree to fix the orientation of the figure.

6.1.4. *The unitary extension of the magma operad.* The magma operad has a unitary extension Ω_+ such that

$$\Omega_+(n) = \begin{cases} *, & \text{if } n = 0, \\ \Omega(n), & \text{otherwise,} \end{cases}$$

and of which composition structure extends the composition structure of the non-unitary operad Ω . In §3.2, we observe that the partial composition operations with the additional arity zero term of such an operad are equivalent to restriction operations $\partial_k : \Omega_+(n) \rightarrow \Omega_+(n - 1)$ so that $\partial_k(p) = p \circ_k *$. Furthermore, for a connected free operad, such as the magma operad $\Omega = \mathcal{O}(\mu(x_1, x_2), \mu(x_2, x_1))$, the associativity of partial composites implies that our restriction operations are uniquely determined by their expression on generating operations $\mu = \mu(x_1, x_2)$ and $t\mu = \mu(x_2, x_1)$ (see §3.4). In the case of the magma operad, we obviously have $\partial_1(\mu) = \partial_2(\mu) = 1$, and $\partial_1(t\mu) = \partial_2(t\mu) = 1$, the operadic unit, since the arity 1 component of our operad is reduced to a one-point set.

The restriction operations $\partial_k(p) = p \circ_k *$ are equivalent to the substitution of a variable by a unit element $*$ in an operad element $p = p(x_1, \dots, x_n)$. The assignment $\partial_1(\mu) = \partial_2(\mu) = 1$ is therefore equivalent to unit identities $\mu(*, x_1) = x_1 = \mu(x_1, *)$ for our generating product operation $\mu(x_1, x_2) = x_1x_2$. In the algebraic approach

The collection $\omega^* Q(r)$, $r \in \mathbb{N}$, therefore forms an operad in groupoids $\omega^* Q$. We refer to this operad as the pullback of the operad Q to the magma generated by the object m in $\mathbf{Ob} Q$.

In the case where our operad Q has a unitary extension Q_+ , we immediately see that the morphism of non-unitary operads $\omega : \Omega \rightarrow \mathbf{Ob} Q$ associated to an element $m \in \mathbf{Ob} Q(2)$ has a unitary extension $\omega_+ : \Omega_+ \rightarrow \mathbf{Ob} Q$ as soon as the relations $m \circ_1 * = m \circ_2 * = 1$ hold in Q_+ . In this situation, we also have a unitary version $\omega^* Q_+$ of the pullback operad $\omega^* Q$ defined by an obvious extension of our construction.

6.1.6. *The pullback of the permutation operad.* We first examine the application of our pullback construction to the permutation operad Π , which is basically defined in the category sets, but which we may also regard as formed of a collection of discrete groupoids. We adopt the notation CoP to distinguish this operad in the category of groupoids from the underlying operad in sets Π , so that we may write $\mathbf{Ob} CoP = \Pi$. Each groupoid $CoP(r)$ is explicitly defined by $\mathbf{Ob} CoP(r) = \Sigma_r$ and we have

$$\text{Mor}_{CoP(r)}(u, v) = \begin{cases} pt, & \text{if } u = v, \\ \emptyset, & \text{otherwise,} \end{cases}$$

for all $u, v \in \Sigma_r$.

Let $m \in \mathbf{Ob} CoP(2)$ be the object defined by the identity permutation $(1, 2) \in \Sigma_2$. The operad morphism $\omega : \Omega \rightarrow \Pi = \mathbf{Ob} CoP$ associated with this element $m \in \mathbf{Ob} CoP(2)$ is obviously identified with the map which sends a parenthesized words $p = p(x_{s(1)}, \dots, x_{s(r)})$ to the underlying permutation $(s(1), \dots, s(r))$ (in the sense of §6.1.3) and forgets about the bracketing (see §6.1.3). Let $PaP = \omega^* CoP$ denote the pullback of the permutation operad under this morphism. This notation PaP refers to the name of parenthesized permutation which we adopt for this operad.

For parenthesized words $p = p(x_{u(1)}, \dots, x_{u(r)})$ and $q = q(x_{v(1)}, \dots, x_{v(r)})$, with $\omega(p) = u$ and $\omega(q) = v$ as underlying permutations, we have:

$$\text{Mor}_{PaP(r)}(p, q) = \begin{cases} pt, & \text{if } \omega(p) = \omega(q), \\ \emptyset, & \text{otherwise.} \end{cases}$$

The morphism $\omega : \Omega \rightarrow \mathbf{Ob} CoP$ clearly admits a unitary extension, and we accordingly have a unitary version of the parenthesized permutation operad PaP_+ such that $PaP_+(0) = *$.

Let $\alpha(x_1, x_2, x_3)$ be the morphism connecting the composites $\mu(\mu(x_1, x_2), x_3) \in \Omega(3)$ and $\mu(x_1, \mu(x_2, x_3)) \in \Omega(3)$ in $PaP(3)$, and oriented in this direction, from $\mu(\mu(x_1, x_2), x_3)$ to $\mu(x_1, \mu(x_2, x_3))$. We refer to such a morphism, making the operation $\mu = \mu(x_1, x_2)$ associative, as an associator. We have the following result, which gives an interpretation of the Mac Lane Coherence Theorem:

THEOREM 6.1.7 (Operadic interpretation of the Mac Lane Coherence Theorem).

- (a) *In each groupoid $PaP(r)$, all morphisms can be obtained as (categorical) composites of morphisms which themselves decompose into operadic composition products of identity morphisms and of the associator $\alpha(x_1, x_2, x_3)$. Naturally, since the morphism sets of the groupoid $PaP(r)$ are either empty or reduced to a one-point set, all parallel morphisms of the parenthesized*

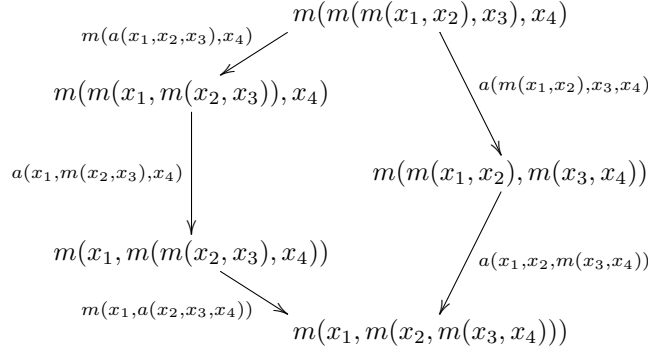

FIGURE 6.1. The pentagon relation

~~braid~~ operad, obtained by such combinations of categorical and operadic composition operations, are equal.

- (b) Now let \mathcal{Q} be any operad in the category of categories. Let

$$m = m(x_1, x_2) \in \mathbf{Ob} \mathcal{Q}(2)$$

be an object in the arity 2 term of this operad. Let

$$a(x_1, x_2, x_3) \in \mathbf{Mor}_{\mathcal{Q}(3)}(m(m(x_1, x_2), x_3), m(x_1, m(x_2, x_3)))$$

be an isomorphism connecting the composites $p = m(m(x_1, x_2), x_3) \in \mathbf{Ob} \mathcal{Q}(3)$ and $q = m(x_1, m(x_2, x_3)) \in \mathbf{Ob} \mathcal{Q}(3)$ in the category $\mathcal{Q}(3)$. If this associator $a = a(x_1, x_2, x_3)$ makes the pentagon diagram of Figure 6.1 commute in $\mathcal{Q}(4)$, then all parallel morphisms of the categories $\mathcal{Q}(r)$ which we obtain from this iso $a = a(x_1, x_2, x_3)$ by combinations of the operations of (a) are equal. In this situation, we also have a morphism of operads in groupoids $\phi : \mathbf{PaP} \rightarrow \mathcal{Q}$ uniquely determined by the assignment $\phi(\mu(x_1, x_2)) = m(x_1, x_2)$ at the object level, and $\phi(\alpha(x_1, x_2, x_3)) = a(x_1, x_2, x_3)$ at the morphism level.

- (c) In the construction of (b), if we moreover assume the existence of an object

$$e \in \mathbf{Ob} \mathcal{Q}(0)$$

satisfying the relation

$$m(e, x_1) = x_1 = m(x_1, e)$$

at the object level, and the relation

$$a(e, x_1, x_2) = a(x_1, e, x_2) = a(x_1, x_2, e) = \text{id}_{m(x_1, x_2)}$$

at the morphism level, then the morphism $\phi : \mathbf{PaP} \rightarrow \mathcal{Q}$ has a unitary extension $\phi_+ : \mathbf{PaP}_+ \rightarrow \mathcal{Q}$ sending the distinguished arity 0 element of the unitary operad of parenthesized permutations \mathbf{PaP}_+ to $e \in \mathbf{Ob} \mathcal{Q}(0)$.

permutation

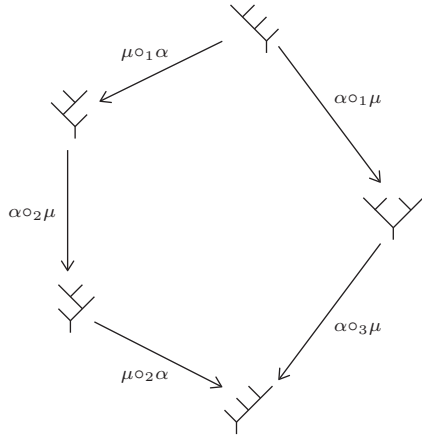

FIGURE 6.2. The associahedra in dimension 2. The edges are given by the image of the associator $\alpha \in \text{Mor } PaP(3)$ under the functors $- \circ_k \mu : PaP(3) \rightarrow PaP(4)$, $k = 1, 2, 3$, and $\mu \circ_k - : PaP(3) \rightarrow PaP(4)$, $k = 1, 2$, in the parenthesized permutation operad PaP .

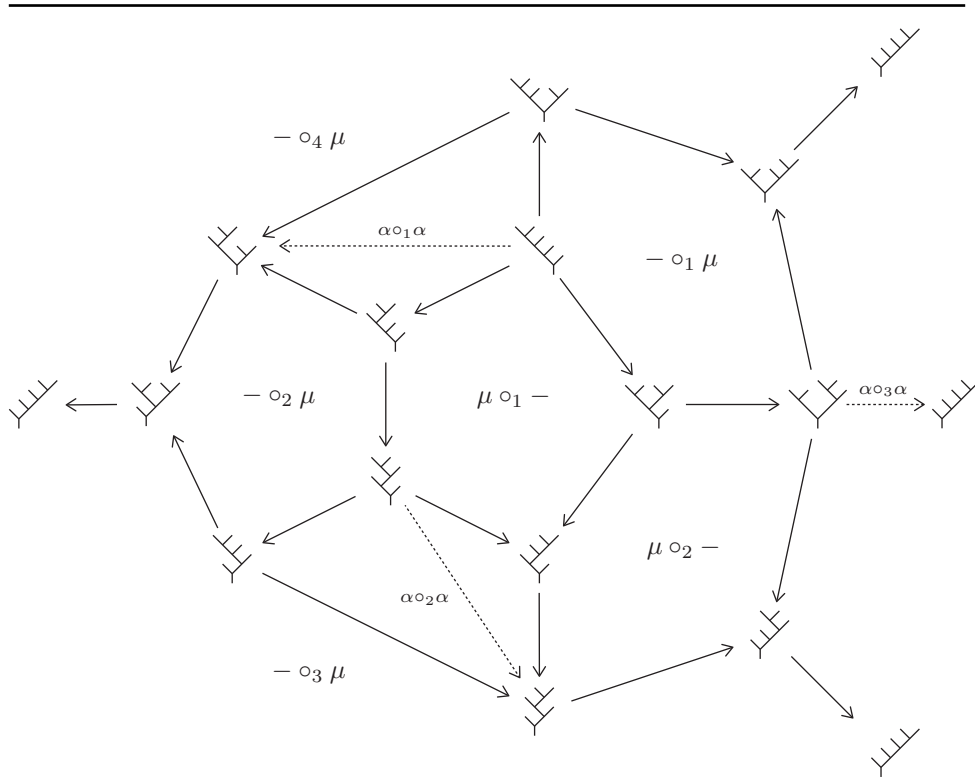

FIGURE 6.3. The stereographic projection of the 3 dimensional associahedra. The binary tree corresponding to the word $(x_1(x_2(x_3(x_4x_5))))$ is put at the infinity of the figure. The pentagon cells in this picture are identified with the image of the pentagon of Figure 6.2 under the functors $- \circ_k \mu : PaP(4) \rightarrow PaP(5)$, $k = 1, 2, 3, 4$, and $\mu \circ_k - : PaP(4) \rightarrow PaP(5)$, $k = 1, 2$, marked in the figure. The square cells correspond to factorization of morphisms $\alpha \circ_k \alpha$, marked by dotted arrows in the figure, and arising from the consideration of bifunctors $- \circ_k - : PaP(3) \times PaP(3) \rightarrow PaP(5)$, $k = 1, 2, 3$.

EXPLANATIONS. The claims of this theorem follow from an operadic interpretation of the Mac Lane Coherence Theorem [122].

To understand the statement of (a-b), we may look at the picture formed by the full subgroupoid of $PaP(r)$ generated by the parenthesized words $p = p(x_{s(1)}, \dots, x_{s(r)})$ for a given underlying permutation $s \in \Sigma_r$. The morphisms of this subgroupoid are identified with paths in a graph, represented in Figure 6.2 in the case $r = 4$, and in Figure 6.3 in the case $r = 5$. To simplify these pictures, we only represent the parenthesization (in the form of binary trees) underlying our objects $p \in \mathbf{Ob} PaP(r)$, and we omit the permutation labeling $(s(1), \dots, (s(r))$ which is by assumption the same for all objects occurring in the figure. In the case $r = 4$, we just retrieve the pentagon diagram of the theorem.

The edges of our graph are operadic composition products of associators and identities. The claim of (a) is therefore equivalent to the connectedness of this graph, which visibly holds in the case $r = 4$ and in the case $r = 5$. The general case of this claim can be established by an easy induction.

The idea beyond our second claim (b) is that the edges of our graphs form the 1-dimensional skeleton of a connected cell complex, whose 2-dimensional cells are equivalent either to the pentagon of Figure 6.1 or to square diagrams. The picture of Figure 6.3 make this observation clear in the case $r = 5$. The edges of our graph form, in general, the 1-dimensional skeleton of a polyhedra, the Stasheff associahedron $K(r)$, $r \in \mathbb{N}$, of which boundary decomposes as a union

$$\partial K(r) = \bigcup_{\substack{\mathbf{m} \circ_{i_k} \mathbf{n} \\ \mathbf{n} = \mathbf{1}}} K(\mathbf{m}) \times K(\mathbf{n}),$$

ranging over operadic composition schemes $p = a(x_{i_1}, \dots, b(x_{j_1}, \dots, x_{j_n}), \dots, x_{i_m})$ (see §3.1, §3.5), and where the summands are identified with cartesian products of associahedra of lower dimension. The form of the 2-dimensional cells of the associahedra can be obtained by induction from the shape of this decomposition. The associahedra actually define an operad in topological space modeling homotopy associative monoids (see [163]). We refer to [67, 111, 119] for various constructions of the associahedra as convex polyhedra and to Stasheff original article [163] for a realization as a cell complex. We can use all these constructions to get a geometrical proof of our statement (see [154]). We can also use a direct inductive argument, forgetting about the geometry of associahedra and focusing on the underlying combinatorics of trees, to establish that all relations between paths in our graph reduce to composites of pentagon and square relations. We refer to Mac Lane's monograph [122] for further details on this purely combinatorial approach.

To establish our assertion (b), we consider the image of our graph in the groupoid $Q(r)$, with the given object $m \in \mathbf{Ob} Q(2)$ and the given associator $a \in \mathbf{Mor} Q(3)$ substituted to the universal object μ and associator α in the parenthesized permutation operad PaP . The assumption on our associator $a(x_1, x_2, x_3)$ implies the commutation of the pentagon diagrams of this graph in the groupoid $Q(r)$. The (bi)functoriality of operadic composition products implies that the squares in our graph commute as well. The graph therefore commutes as a whole and this assertion gives the crux of the claim of (b). Indeed, the commutation of the graph implies that the image of our graph in the groupoid $Q(r)$ gives a coherent definition of groupoid morphisms $\phi : PaP(r) \rightarrow Q(r)$, for all $r \in \mathbb{N}$, preserving our operad structures.

The requirements of (c) imply that our operad morphism $\phi : PaP \rightarrow Q$ makes the composite with the arity zero term $*$ in the unitary extension of the operad PaP correspond to the composite with the object e in the operad Q . Therefore, we immediately obtain that our operad morphism $\phi : PaP \rightarrow Q$ admits an extension $\phi_+ : PaP_+ \rightarrow Q$ to the unitary operad PaP_+ as soon as we have an object e satisfying our conditions in Q . \square

To sum up, the result of Theorem 6.1.7 gives an equivalence between operad morphisms $\phi : PaP \rightarrow Q$ and pairs (m, a) consisting of an operation $m = m(x_1, x_2) \in \mathbf{Ob} Q(2)$ and an isomorphism $a = a(x_1, x_2, x_3) \in \mathbf{Mor} Q(3)$ which makes this operation associative in the operad Q . In the expression of this associativity relation, we assume the verification of coherence constraints, which can be reduced to the commutativity of the pentagon diagram of Figure 6.1. In the unitary case, we consider an additional object $e \in Q(0)$ satisfying strict unit relations $m(e, x_1) = x_1 = m(x_1, e)$ with respect to the product m , and the natural coherence constraints with respect to the associator.

For comparison, in the case of the discrete groupoid operad CoP we have the following statement:

THEOREM 6.1.8.

- (a) *Giving a morphism $\phi : CoP \rightarrow Q$ from the permutation operad CoP towards an operad in groupoids Q amounts to giving an object*

$$m(x_1, x_2) \in \mathbf{Ob} Q(2)$$

satisfying a strict associativity relation

$$m(m(x_1, x_2), x_3) = m(x_1, m(x_2, x_3))$$

in the operad Q .

- (b) *In the construction of (a), if we moreover assume the existence of an object*

$$e \in \mathbf{Ob} Q(0) \quad \text{such that} \quad m(e, x_1) = x_1 = m(x_1, e),$$

then the morphism $\phi : CoP \rightarrow Q$ has a unitary extension $\phi_+ : CoP_+ \rightarrow Q$ sending the distinguished arity 0 element of the unitary operad of permutations $\Pi_+ = \mathbf{Ob} CoP_+$ to this object $e \in \mathbf{Ob} Q(0)$.

PROOF. If we regard an operad in sets P as a collection of discrete groupoids, then giving a morphism of operads in groupoids $\phi : P \rightarrow Q$ reduces to giving a morphism of operads in sets $\phi : P \rightarrow \mathbf{Ob} Q$ towards the object operad underlying Q . In the case of the permutation operad $P = \Pi$, we deduce from the presentation by generators and relations of §1 that giving such a morphism reduces to giving an operation $m \in Q(2)$ satisfying the associativity relation on Q . The argument is similar in the unitary case. \square

6.1.9. The operadic representation of monoidal structures on categories. Recall that the action of an operad P on an object A in a base symmetric monoidal category \mathcal{M} is equivalent to a morphism $\phi : P \rightarrow \mathbf{End}_A$, where \mathbf{End}_A is the endomorphism operad of A . In the case where we work within the category of (small) categories $\mathcal{M} = \mathbf{Cat}$ and we deal with an object $\mathcal{C} \in \mathbf{Cat}$, the endomorphism operad $\mathbf{End}_{\mathcal{C}}$ is given in arity r by the category which has the r -functors $f : \mathcal{C}^{\times r} \rightarrow \mathcal{C}$ as objects and the natural transformation between them as morphisms.

From the results established in this section, we obtain that giving a morphism $\phi : PaP_+ \rightarrow \text{End}_{\mathcal{C}}$ amounts to giving a monoidal structure on \mathcal{C} with strict unit relations but general associativity isomorphisms (see [122]), while giving a morphism $\phi : CoP_+ \rightarrow \text{End}_{\mathcal{C}}$ is equivalent to giving a monoidal structure with both strict unit and strict associativity relations. In both cases, we take the image of the object $\mu = \mu(x_1, x_2)$ under ϕ to get the tensor product operation $m(X_1, X_2) = X_1 \otimes X_2 : \mathcal{C} \times \mathcal{C} \rightarrow \mathcal{C}$ of the monoidal structure on \mathcal{C} . In the unitary setting, we also take the image of the unitary element of the operad $* \in P_+(0)$ to get a natural transformation $e : pt \rightarrow \mathcal{C}$ equivalent to a unit object $\mathbb{1} \in \mathcal{C}$ for this tensor product in \mathcal{C} . In the parenthesized permutation operad case, we take the image of the associator $\alpha \in \text{Mor } P(3)$ to get a natural isomorphism $a(X_1, X_2, X_3) : (X_1 \otimes X_2) \otimes X_3 \xrightarrow{\cong} X_1 \otimes (X_2 \otimes X_3)$ making our tensor product associative. In the colored permutation case, we assume that this associativity relation holds strictly $(X_1 \otimes X_2) \otimes X_3 = X_1 \otimes (X_2 \otimes X_3)$ and we take the identity isomorphism as associator $a = id$. The pentagon relation of Theorem 6.1.7 is nothing but the usual coherence axiom of [122] for the associativity isomorphism of a monoidal category, and we have a similar correspondence for the coherence constraints associated with the unit object. This identity gives the correspondence between the results of Theorem 6.1.7-6.1.8 and the definition of monoidal structures on a category \mathcal{C} .

To complete the account of this section, we record the following result which motivates the introduction of the pullback construction of §6.1.5 for operads in groupoids:

PROPOSITION 6.1.10. *Let P be an operad in groupoid which has the magma operad as underlying object operad $\text{Ob } P = \Omega$. For any lifting problem*

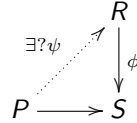

such that ϕ is a categorical equivalence of operads in groupoids (see §5.2.2), we have a fill-in morphism ψ that make the diagram commute in the strict sense.

PROOF. Exercise. □

6.2. The parenthesized braid operad

Recall that the operad of colored braids CoB satisfies $\text{Ob } CoB = \Pi$. We define the operad of parenthesized braids PaB by applying the pullback construction of §6.1.5 to this operad CoB . We explicitly take $PaB = \omega^* CoB$, where we again consider the morphism $\omega : \Omega \rightarrow \Pi$ mapping a parenthesized word $p = p(x_{s(1)}, \dots, x_{s(r)}) \in \Omega(r)$ to its underlying permutation $s \in \Sigma_r$ (as in §6.1.6). We then have $\text{Ob } PaB(r) = \Omega(r)$ for each r , and $\text{Mor}_{PaB(r)}(p, q) = \text{Mor}_{CoB(r)}(\omega(p), \omega(q))$ for any pair of parenthesized words $p = p(x_{u(1)}, \dots, x_{u(r)})$ and $q = q(x_{v(1)}, \dots, x_{v(r)})$ with $u = \omega(p)$ and $v = \omega(q)$ as underlying permutations. The symmetric group actions, the unit, and the composition operations defining the operad structure on this collection of groupoids are inherited from the magma operad at the object level, and from the colored braid operad at the morphism level (see §6.1.5). The

parenthesized braid operad has a unitary version (like the parenthesized permutation operad) which is defined by an obvious unitary extension of our pullback construction.

Recall that we use the notation CoP for the permutation operad Π regarded as an operad in groupoids. In the colored operad case, we have an obvious morphism of operads in groupoids $\iota : CoP \rightarrow CoB$ given by the identity $0b CoB = \Pi$ at the object level. This morphism admits a lifting

$$\begin{array}{ccc} PaP & \xrightarrow{\quad} & PaB, \\ \downarrow & & \downarrow \\ CoP & \xrightarrow{\quad \iota \quad} & CoB \end{array}$$

which identifies the operad of parenthesized permutations PaP with a suboperad of PaB such that $0b PaB = 0b PaP = \Omega$. This operad embedding construction has an obvious extension in the unitary setting.

The main purpose of this section is to give an analogue of Theorem 6.1.7 for the parenthesized braid operad. To complete our account, we also record an analogue of the result of Theorem 6.1.8 for the colored braid operad. But before examining this question we give a topological interpretation of the operad PaB in terms of the fundamental groupoid of the little 2-discs operad πD_2 .

6.2.1. *Parenthesized braids and fundamental groupoid elements.* In the definition of the operad of colored braids CoB , we make a choice of contact points a on the medium axis $y = 0$ of the open disc \mathring{D}^2 . The planar binary trees, defining the objects of the groupoids $PaB(r)$, actually have an analogous topological interpretation in terms of configurations of contact points on the line $y = 0$.

Instead of the equidistant contact points of §5.0, we just consider the centers of diadic decompositions of the axis $y = 0$ of the open disc \mathring{D}^2 . In the next proposition, we establish that these configurations of points are associated to little 2-discs configurations defining a free operad, isomorphic to the magma operad, inside the little 2-disc operad D_2 . The correspondence between these diadic decompositions, the free suboperad of little 2-discs, and the planar binary trees of the magma operad, is made explicit in the picture of Figure 6.4.

In the proposition, we use this correspondence and we elaborate on the proof of Theorem 5.3.4 to identify the parenthesized braid operad PaB with a suboperad of the operad πD_2 formed by the fundamental groupoids of the little 2-discs spaces. In the sequel, we essentially use the correspondence of this proposition to get a convenient representation, elaborating on observations of the previous chapter (§5.3.5), for the morphisms of the parenthesized braid operad. Figure 6.5 provides the picture of such a morphism in the parenthesized braid operad. In general, we use the simplified representation, where the source and target of our morphism are replaced by the corresponding diadic decompositions of the interval, rather than the perspective representation given in this figure.

PROPOSITION 6.2.2.

(a) *The little 2-disc configuration*

$$\mu = \left(\begin{array}{c} \bigcirc \\ \bigcirc \quad \bigcirc \\ \bigcirc \end{array} \right) \in D_2(2)$$

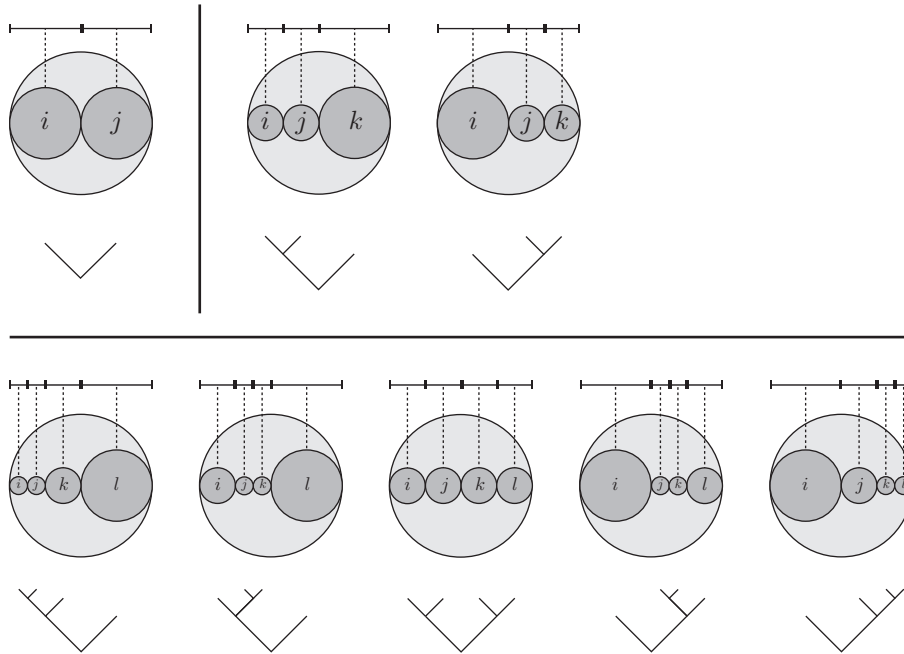

FIGURE 6.4. The correspondence between binary trees, operadic composites of a generating little 2-disc configurations and diadic decompositions of the interval in arity $r = 2, 3, 4$. The indices (i, j) , (i, j, k) , (i, j, k, l) , \dots run over permutations of $(1, 2)$, $(1, 2, 3)$, $(1, 2, 3, 4)$, \dots The diadic decompositions of the interval are counterparts, in the little 1-disc operad, of the little 2-disc composites considered in this picture (see proof of Proposition 6.2.2 for detailed explanations).

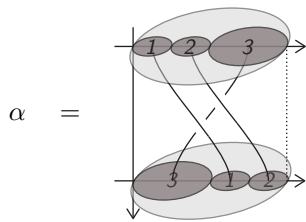

FIGURE 6.5. The picture, in the fundamental groupoid of the little 2-discs operad, of a morphism of the parenthesized braid operad.

- generates a free operad, isomorphic to Ω , within the little 2-disc operad D_2 .
- (b) The disc center mapping of §4.2.2, applied point-wise to paths in little 2-disc spaces, induces an isomorphism

$$\omega_* : \pi D_2 \upharpoonright_{\Omega} \xrightarrow{\cong} PaB$$

between the restriction of the fundamental groupoid operad of D_2 to the suboperad $\Omega \subset D_2$ and the operad of parenthesized braids PaB .

PROOF. Let $\phi : \Omega \rightarrow D_2$ be the morphism sending the generating element $\mu \in \Omega(2)$ of the free operad Ω to the little 2-disc configuration $\mu \in D_2(2)$ of assertion (a). The claim of assertion (a) is that this morphism defines an embedding. In our verification, we use the symmetric collection equivalent to the magma operad Ω , and we consider monomials $p = p(x_{i_1}, \dots, x_{i_r}) \in \Omega(\underline{r})$ of which variables may be indexed by an arbitrary finite set $\underline{r} = \{i_1, \dots, i_r\}$ (not necessarily a standard ordinal). Since μ visibly comes from the operad of little 1-discs D_1 , regarded as a suboperad of D_2 (see §4.1.5 and §5.1.7), our morphism ϕ admits a factorization through D_1 , and we are therefore reduced to prove that this factorization $\phi : \Omega \rightarrow D_1$ is an injection. Equivalently, we look at the trace of little 2-disc configurations $\underline{c} \in D_2(r)$ on the axis $y = 0$ in the ambient disc \mathbb{D}^2 to determine the counter-image of elements \underline{c} in Ω . (Recall that the image of D_1 in D_2 consists of configurations of little disc centered on this axis $y = 0$, and the trace, considered in our process, can be used to determine the counter-image in D_1 of an element of D_2 .)

The little interval configurations lying in the image of our map ϕ are associated with diadic decomposition of the interval $[-1, 1]$ (see Figure 6.4 for examples). To retrieve an element of Ω from the corresponding little interval configuration \underline{c} , just observe that we have $\underline{c} = \mu(\underline{a}, \underline{b})$ where $\underline{a} \in D_1(\{i_1, \dots, i_m\})$ (respectively, $\underline{b} \in D_1(\{j_1, \dots, j_n\})$) is produced by applying the affine transformation $t \mapsto 2t + 1$ (respectively, $t \mapsto 2t - 1$) to the configuration of little intervals lying in the subinterval $[-1, 0] \subset [-1, 1]$ (respectively, $[0, 1] \subset [-1, 1]$) in the collection \underline{c} . We continue by induction to obtain the full decomposition of \underline{c} and to determine the counter-image of \underline{c} in Ω .

The second claim of the proposition is a variation on the result of Theorem 5.2.12. Simply note that we now have a direct isomorphism $\omega_* : \pi D_2 \downarrow_{\Omega} \xrightarrow{\cong} PaB$ lifting the chain of category equivalences

$$\begin{array}{ccc}
 \pi D_2(r) \downarrow_{\Omega(r)} & \xrightarrow{\omega_*} & PaB(r) \\
 \downarrow & & \downarrow \\
 \pi D_2(r) \downarrow_{D_1(r)} & \longrightarrow & CoB(r) \\
 \downarrow & & \\
 \pi D_2(r) & &
 \end{array}$$

considered in the proof of Theorem 5.2.12. □

We must note that the isomorphism of the proposition $\omega_* : \pi D_2 \downarrow_{\Omega} \xrightarrow{\cong} PaB$ does not extend to a morphism of unitary operads. We therefore need to go back to the rectification process of Theorem 5.3.4 when we deal with restriction morphisms $u^* : PaB_+(n) \rightarrow PaB_+(m)$ defining the composition operations with the additional term $PaB_+(0) = *$ of the unitary parenthesized braid operad PaB_+ .

6.2.3. *The associator and the braiding in the parenthesized braid operad.* The morphism $\iota : PaP \rightarrow PaB$ considered in the introduction of this section is given by the identity $0b PaB = 0b PaP = \Omega$ on object sets and is defined at the morphism level by sending the associator $\alpha \in \text{Mor } PaP(3)$ in the parenthesized permutation

operad to the morphism

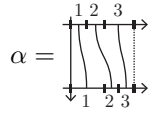

in the parenthesized braid operad. The pentagon relation of Figure 6.1 is equivalent to the identity of the following parenthesized braid diagrams

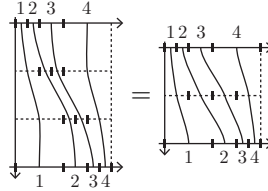

in $PaB(4)$. The cover picture of this volume is the perspective representation of this pentagon relation in the morphism set of the fundamental groupoid of the little 2 discs space $D_2(4)$.

Besides the associator $\alpha \in \text{Mor } PaB(3)$, we consider the morphism

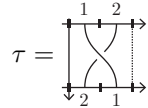

which we call the braiding. We readily see that the associator and the braiding satisfy hexagon coherence constraints expressed in Figure 6.6 (in algebraic terms) and equivalent to the identity of the following parenthesized braid diagrams

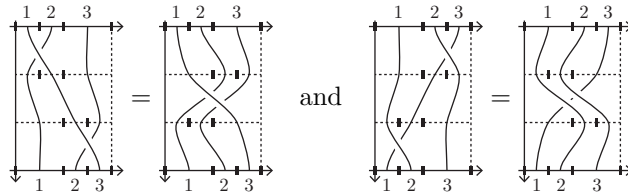

in $PaB(3)$.

We can now formulate the analogue of Theorem 6.1.7 for the parenthesized braid operad:

THEOREM 6.2.4.

- (a) *In each groupoid $PaB(r)$, all morphisms can be obtained as (categorical) composites of morphisms which themselves decompose into operadic composition products of identity morphisms, of the associator $\alpha \in \text{Mor } PaB(3)$, and of the braiding $\tau \in \text{Mor } PaB(2)$.*
- (b) *Let Q be any operad in the category of categories. Let*

$$m = m(x_1, x_2) \in \text{Ob } Q(2)$$

be an object in the arity 2 component of this operad. Let

$$a(x_1, x_2, x_3) \in \text{Mor}_{Q(3)}(m(m(x_1, x_2), x_3), m(x_1, m(x_2, x_3)))$$

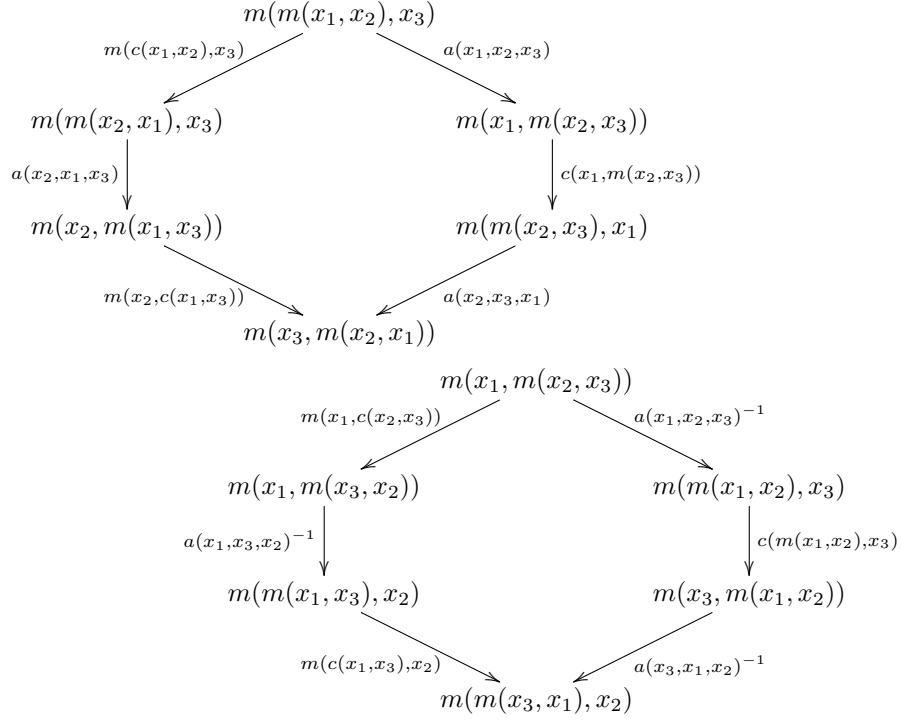

FIGURE 6.6. The hexagon relations

be an isomorphism connecting the composites $p = m(m(x_1, x_2), x_3) \in \mathbf{Ob} \mathcal{Q}(3)$ and $q = m(x_1, m(x_2, x_3)) \in \mathbf{Ob} \mathcal{Q}(3)$ in the category $\mathcal{Q}(3)$. Let

$$c(x_1, x_2) \in \mathbf{Mor}_{\mathcal{Q}(2)}(m(x_1, x_2), m(x_2, x_1))$$

be an isomorphism connecting the operation $m = m(x_1, x_2) \in \mathbf{Ob} \mathcal{Q}(2)$ to its transpose $tm = m(x_2, x_1) \in \mathbf{Ob} \mathcal{Q}(2)$ in the category $\mathcal{Q}(2)$. If these isos $a = a(x_1, x_2, x_3)$ and $c = c(x_1, x_2)$ make the pentagon diagram of Figure 6.1 and the hexagon diagrams of Figure 6.6 commute, then we have a morphism of operads in groupoids $\phi : \mathbf{PaB} \rightarrow \mathcal{Q}$ uniquely determined by the assignment $\phi(\mu) = m(x_1, x_2)$, $\phi(\alpha) = a(x_1, x_2, x_3)$ and $\phi(\tau) = c(x_1, x_2)$.

(c) In the construction of (b), if we moreover assume the existence of an object

$$e \in \mathbf{Ob} \mathcal{Q}(0)$$

satisfying the relation

$$m(e, x_1) = x_1 = m(x_1, e)$$

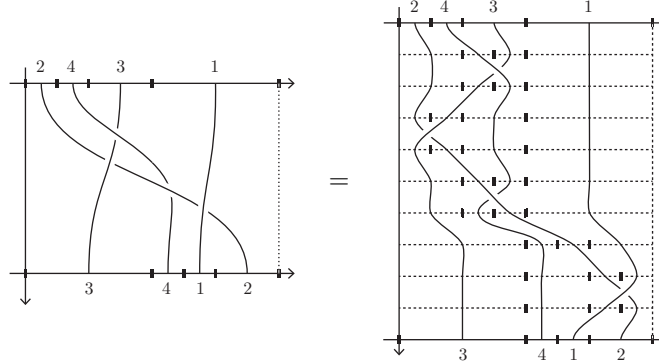

FIGURE 6.7. An instance of a parenthesized braid decomposition.

at the object level, and the identities

$$a(e, x_1, x_2) = a(x_1, e, x_2) = a(x_1, x_2, e) = id_{m(x_1, x_2)},$$

$$c(e, x_1) = c(x_1, e) = id_{x_1}$$

at the morphism level, then the morphism $\phi : PaB \rightarrow Q$ has a unitary extension $\phi_+ : PaB_+ \rightarrow Q$ sending the distinguished arity 0 element of the unitary operad of parenthesized braids PaP_+ to this object $e \in Ob Q(0)$.

PROOF. We subdivide the proof of this theorem in several steps.

Step 1: The decomposition of morphisms in the parenthesized braid operad. We first prove that any given morphism $\beta \in Mor_{PaB(r)}(p, q)$ has a decomposition of the form specified in assertion (a). We suggest the reader to follow our argument lines on the example depicted in Figure 6.7.

We have $Mor_{PaB(r)}(p, q) = Mor_{CoB(r)}(\omega(p), \omega(q)) \subset B_r$ by definition of the groupoids of parenthesized braids. We immediately obtain therefore that our morphism $\beta \in Mor_{PaB(r)}(p, q)$ admits a decomposition

$$\beta = \beta_1 \cdots \beta_n,$$

where each factor $\beta_i \in Mor_{PaB(r)}(p_i, q_i)$ consists, after forgetting about parenthesizations, of a single generating factor τ_k in the braid group B_r .

If $p_i = p_i(x_{s(1)}, \dots, x_{s(r)})$ has $s = (s(1), \dots, s(k), s(k+1), \dots, s(r))$ as underlying permutation, then q_i has an underlying permutation of the form $st_k = (s(1), \dots, s(k+1), s(k), \dots, s(r))$, with the factors $(s(k), s(k+1))$ switched. We pick a parenthesization gathering the factors $x_{s(k)}$ and $x_{s(k+1)}$ in the word $x_{s(1)} \cdots x_{s(r)}$. We thus consider a parenthesized word of the form

$$\kappa_i = \pi_i(x_{s(1)}, \dots, \mu(x_{s(k)}, x_{s(k+1)}), \dots, x_{s(r)}) \in \Omega(r),$$

where $\pi_i \in \Omega(r-1)$. By Theorem 6.1.7(a), we have a parenthesized permutation operad morphism

$$\rho = \rho(x_{s(1)}, \dots, x_{s(k)}, x_{s(k+1)}, \dots, x_{s(r)}) \in Mor PaP(r),$$

formed by a composite of associators, connecting p_i to κ_i . We similarly have a morphism

$$\sigma = \sigma(x_{s(1)}, \dots, x_{s(k+1)}, x_{s(k)}, \dots, x_{s(r)}) \in \text{Mor } PaP(r)$$

going from q_i to $\lambda_i = \pi_i(x_{s(1)}, \dots, \mu(x_{s(k+1)}, x_{s(k)}), \dots, x_{s(r)})$. We therefore have a decomposition of each morphism β_i of the form

$$\begin{aligned} \beta_i &= \sigma(x_{s(1)}, \dots, x_{s(k+1)}, x_{s(k)}, \dots, x_{s(r)})^{-1} \\ &\quad \cdot \pi_i(x_{s(1)}, \dots, \tau(x_{s(k)}, x_{s(k+1)}), \dots, x_{s(r)}) \\ &\quad \cdot \rho(x_{s(1)}, \dots, x_{s(k)}, x_{s(k+1)}, \dots, x_{s(r)}) \end{aligned}$$

where ρ and σ are defined by composites of associators, and the medium factor $s \cdot id_{\pi_i} \circ_k \tau$ reduces to the application of a braiding τ within a fixed parenthesized word.

This observation completes the proof of assertion (a) of the theorem.

Step 2: The construction of the category morphisms $\phi(r) : PaB(r) \rightarrow Q(r)$. The result of Theorem 6.1.7(b) implies the existence (and uniqueness) of a morphism $\phi : PaP \rightarrow Q$, determined by the assignments $\phi(\mu) = m$ and $\phi(\alpha) = a$, whenever we have an object $m \in \text{Ob } Q(2)$ and an associator $a \in \text{Mor } Q(3)$ satisfying the pentagon relation of Figure 6.1. The aim of our next verifications is to establish that this morphism $\phi : PaP \rightarrow Q$ has an extension to the parenthesized braid operad PaB , uniquely determined by the additional assignment $\phi(\tau) = c$, for a symmetry operator $c \in \text{Mor } Q(2)$ satisfying the hexagon relations of Figure 6.6.

The definition of the morphism $\phi : PaP \rightarrow Q$ includes the definition of a mapping $\phi : \Omega(r) \rightarrow Q(r)$ at the object level, for each $r \in \mathbb{N}$. In this second step, we aim to define a corresponding mapping $\phi : \text{Mor } PaB(r) \rightarrow \text{Mor } Q(r)$ at the morphism level, and to complete the construction of a groupoid morphism $\phi(r) : PaB(r) \rightarrow Q(r)$, for each $r \in \mathbb{N}$.

The image of a morphism $\beta \in \text{Mor}_{PaB(r)}(p, q)$ under an operad morphism $\phi : PaB \rightarrow Q$ is actually uniquely determined from the decomposition obtained in Step 1 and the assignments $\alpha \mapsto a = a(x_1, x_2, x_3)$, $\tau \mapsto c = c(x_1, x_2)$, since our operad morphism is supposed to commute with all structure operations involved in this decomposition. For instance, in the case of the braid of Figure 6.5, we obtain an image of the form

$$\begin{aligned} \phi(\beta) &= m(1, a^{-1}) \cdot m(1, m(1, c)) \cdot m(1, a) \cdot a(1, m, 1) \cdot m(m(1, c), 1) \\ &\quad \cdot m(a, 1) \cdot m(m(c, 1), 1) \cdot m(a^{-1}, 1) \cdot m(m(1, c), 1) \cdot m(a, 1) \end{aligned}$$

in $\text{Mor } Q(4)$ (where we do not mark input permutations to simplify our expression).

The main purpose of our verifications is to establish that the mapping

$$\phi(r) : \text{Mor}_{PaB(r)}(p, q) \rightarrow \text{Mor}_Q(\phi(p), \phi(q)),$$

which we determine from this decomposition process in Step 1, does not depend on choices involved in the operation.

The Mac Lane Coherence Theorem implies that $\phi(\beta)$ does not depend on the choice of the associator decompositions between the parenthesized words occurring in our factorization. We also see that the outcome of our construction does not depend on the parenthesizations $\pi \in \Omega(r-1)$, which we chose to gather the

factors of the braiding operations in our words. Indeed, we can go from one parenthesization $\kappa_i = \kappa_i(x_1, \dots, x_{r-1})$ to another one $\lambda_i = \lambda_i(x_1, \dots, x_{r-1})$ by a morphism $\rho = \rho(x_1, \dots, x_{r-1})$ defined within the parenthesized permutation operad and formed by a composite of associators therefore. The middle square in the commutative diagram

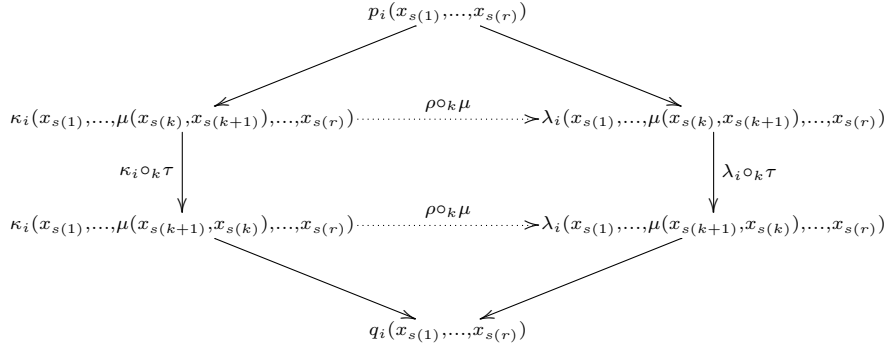

is carried to a commutative square by our morphism ϕ , for any choice of assignment $c = \phi(\tau)$, because the composition products of operads in categories $\circ_k : \mathcal{Q}(m) \times \mathcal{Q}(n) \rightarrow \mathcal{Q}(m+n-1)$ is a category morphism (or equivalently, defines a bifunctor). The external triangles are carried to commutative triangles too (by the Mac Lane Coherence Theorem), and we conclude that both paths from $p_i = p_i(x_{s(1)}, \dots, x_{s(r)})$ to $q_i = q_i(x_{s(1)}, \dots, x_{s(r)})$ yield the same morphism in \mathcal{Q} .

We still have to establish that the morphism $\phi(\beta)$ does not depend on the decomposition $\beta = \beta_1 \cdot \dots \cdot \beta_n$ formed from the image of the morphism β in the braid group B_r . We are reduced to check, for this purpose, that the application of the generating relations of braids does not change the result of our construction.

In the case of the commutation relations

$$\tau_k \tau_l = \tau_l \tau_k,$$

we assume that a parenthesization of the form

$$\lambda_i = \pi_i(x_{s(1)}, \dots, \mu(x_{s(k)}, x_{s(k+1)}), \dots, \mu(x_{s(l)}, x_{s(l+1)}), \dots, x_{s(r)})$$

is chosen when we proceed to determine the image of the factors β_i and β_{i+1} associated with the elementary braids of this relation. The identity of the result associated to the decompositions

$$\beta = \beta_1 \cdot \dots \cdot \beta_i \cdot \beta_{i+1} \cdot \dots \cdot \beta_n = \beta_1 \cdot \dots \cdot \beta_{i+1} \cdot \beta_i \cdot \dots \cdot \beta_n$$

follows, in that case, from the associativity of the composition product of operads.

In the case of the braiding relations

$$\tau_k \tau_{k+1} \tau_k = \tau_{k+1} \tau_k \tau_{k+1},$$

we assume that a parenthesization of the form

$$\lambda_i = \pi_i(x_{s(1)}, \dots, \mu(\mu(x_{s(k)}, x_{s(k+1)}), x_{s(k+2)}), \dots, x_{s(r)})$$

is chosen when we proceed to determine the image of the factors associated with the elementary braids of the relation. The identity of our morphisms in \mathcal{Q} reduces in that case to the commutation of the duodecagon diagram of Figure 6.8, which we establish next (in Lemma 6.2.5).

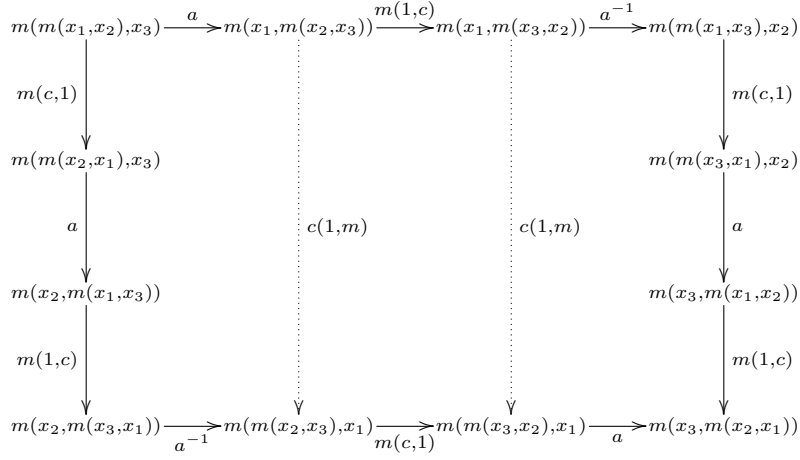

FIGURE 6.8. The duodecagon relation

Step 3: The preservation of operadic composition structures. In the previous step, we checked that we have a coherent definition of morphisms of small categories $\phi : PaB(r) \rightarrow Q(r)$, extending the components of an operad morphism $\phi : PaP \rightarrow Q$ on the parenthesized permutation operad PaP . The purpose of this third step is to check that our morphisms of small categories $\phi : PaB(r) \rightarrow Q(r)$ actually define an operad morphism on the parenthesized braid operad PaB . The equivariance and the preservation of operadic unit are immediate, and the preservation of operadic composition products at the object level follows from the definition of our morphisms as extensions of the components of an operad morphism on the parenthesized permutation operad. We are therefore reduced to check the preservation of operadic composition products on the morphisms of the parenthesized braid operad.

The decomposition of morphisms, which we have used to determine the mapping on morphisms $\phi : \text{Mor } PaB(r) \rightarrow \text{Mor } Q(r)$ in Step 2, can be applied to reduce the verification of the relations $\phi(\beta \circ_k \gamma) = \phi(\beta) \circ_k \phi(\gamma)$ to generating cases. The preservation of operadic composites with associators is also included in the definition of our morphisms of small categories as extensions of the components of an operad morphism on the parenthesized permutation operad. We therefore reduce our verifications to the case where β (respectively, γ) is an identity morphism in PaB and γ (respectively, β) is given by the application of a braiding τ within a parenthesized word.

The verification of the relation $\phi(\beta \circ_k \gamma) = \phi(\beta) \circ_k \phi(\gamma)$ is immediate when β is the identity and the braiding occurs in the second factor γ . Thus we focus on the case where the braiding occurs in the first factor β .

We assume $\beta = \kappa(x_1, \dots, \tau(x_l, x_{l+1}), \dots, x_m)$ and $\gamma = id_\lambda$, for some $\kappa \in \Omega(m-1)$, $l \in \{1, \dots, m-1\}$, and $\lambda \in \Omega(n)$. We can still use the decomposition of the word λ within the magma operad to reduce our verification to the case where $\lambda = \mu$ and $n = 2$. If $\gamma = id_\mu$ is plugged in an input $k \neq l, l+1$ of the word $\beta = \kappa(x_1, \dots, \tau(x_l, x_{l+1}), \dots, x_m)$, then our relation follows from the associativity of the

composition products in \mathcal{Q} . If $\gamma = id_\mu$ is plugged in an input $k = l, l + 1$ of the braiding $\tau = \tau(x_l, x_{l+1})$ within the composite $\beta = \kappa(x_1, \dots, \tau(x_l, x_{l+1}), \dots, x_m)$, then we see that the decomposition of the morphism $\tau(x_l, x_{l+1}) \circ_k id_\mu$, involved in the construction of our map $\phi : \beta \circ_k \gamma$, amounts to the application of the hexagon relations of Figure 6.6 within the parenthesized braid operad. The commutation of these diagrams in \mathcal{Q} implies the preservation of the operadic composition operation in this remaining case.

This verification completes the proof of assertion (b) of the theorem.

Step 4: the definition of the unitary extension of our morphism. To address the proof of assertion (c), we just observe that the relations of this assertion, which read $m \circ_1 e = m \circ_2 e = 1$, $a \circ_1 id_e = a \circ_2 id_e = a \circ_3 id_e = id_m$, and $c \circ_1 id_e = c \circ_2 id_e = id_1$, amounts to requiring that the assignment $\phi : * \mapsto e$ gives a coherent extension of our morphism $\phi : PaB \rightarrow \mathcal{Q}$ when we consider the image of the object $\mu \in \mathbf{Ob} PaB(2)$, and of the morphisms $\alpha \in \mathbf{Mor}_{PaB(3)}(((x_1 x_2) x_3), (x_1 (x_2 x_3)))$, $\tau \in \mathbf{Mor}_{PaB(2)}((x_1 x_2), (x_2 x_1))$ under the restriction operations $\partial_k = - \circ_k *$ in PaB . The decomposition obtained in the preliminary step then implies that ϕ carries any restriction operation in PaB to the corresponding composite with the object e in the operad \mathcal{Q} . The conclusion follows. \square

The next lemma, which we use in the proof of Theorem 6.2.4, is a standard statement of the theory of braided monoidal categories (see [93]):

LEMMA 6.2.5. *If the morphisms $a(x_1, x_2, x_3)$ and $c(x_1, x_2)$ in Theorem 6.2.4 make the hexagon diagrams of Figure 6.6 commute, then the duodecagon of Figure 6.8, tiled with two hexagons and one square, commutes as well. (To simplify, we do not mark input permutations in the morphisms of this diagram.)*

We suggest the reader to make these relations explicit for the associator α and the braiding τ of the parenthesized braid operad PaB .

PROOF. The left hand side and right hand side hexagons in the duodecagon tiling of the lemma are identified with the hexagons of Figure 6.6 (with a factor $a^{\pm 1}$ inverted) and therefore, these hexagons commute. The medium square commutes as well. Indeed, for the morphism $c = c(x_1, x_2)$, going from $m = m(x_1, x_2)$ to $(1\ 2) \cdot m = m(x_2, x_1)$, the functoriality of the composition product $\circ_2 : \mathcal{Q}(2) \times \mathcal{Q}(2) \rightarrow \mathcal{Q}(3)$ gives $c \circ_2 ((1\ 2) \cdot m) \cdot m \circ_2 c = c \circ_2 c = ((1\ 2) \cdot m) \circ_2 c \cdot c \circ_2 m$, which is the identity asserted by the commutation of that square. \square

To sum up, the result of Theorem 6.2.4 gives an equivalence between operad morphisms $\phi : PaB \rightarrow \mathcal{Q}$ and triples (m, a, c) consisting of an operation $m = m(x_1, x_2) \in \mathbf{Ob} \mathcal{Q}(2)$, an isomorphism $a = a(x_1, x_2, x_3) \in \mathbf{Mor} \mathcal{Q}(3)$ (an associator), which makes this operation associative in the operad \mathcal{Q} , and an isomorphism $c = c(x_1, x_2) \in \mathbf{Mor} \mathcal{Q}(2)$ (a braiding), which makes m braided commutative in the sense that we have $c(x_1, x_2) : m(x_1, x_2) \xrightarrow{\cong} m(x_2, x_1)$, but we do not necessarily get the identity of the object $m = m(x_1, x_2)$ when we go back to m by applying this symmetry iso twice. In both the expression of the associativity and symmetry relations, we assume the verification of coherence constraints, which can be reduced to the commutativity of the pentagon diagram of Figure 6.1 in the associativity case and of the hexagon diagrams of Figure 6.6 in the symmetry case. In the unitary case, we consider an additional object $e \in \mathcal{Q}(0)$ satisfying strict unit relations

$m(e, x_1) = x_1 = m(x_1, e)$, with respect to the product m , and the natural coherence constraints with respect to the associator and the braiding.

For comparison, in the case of the colored braid operad, we obtain the following statement:

THEOREM 6.2.6.

- (a) *Giving a morphism $\phi : \mathbf{CoB} \rightarrow \mathbf{Q}$ from the colored braid operad \mathbf{CoB} towards an operad in categories \mathbf{Q} amounts to giving an object*

$$m(x_1, x_2) \in \mathbf{Ob} \mathbf{Q}(2)$$

and an isomorphism

$$c(x_1, x_2) \in \mathbf{Mor}_{\mathbf{Q}(2)}(m(x_1, x_2), m(x_2, x_1))$$

so that the strict associativity relation

$$m(m(x_1, x_2), x_3) = m(x_1, m(x_2, x_3))$$

holds in the operad \mathbf{Q} , and the hexagons of Figure 6.6, where we take $a = id$, commute.

- (b) *In the construction of (a), if we moreover assume the existence of an object*

$$e \in \mathbf{Ob} \mathbf{Q}(0) \quad \text{such that} \quad m(e, x_1) = x_1 = m(x_1, e),$$

$$\text{and} \quad c(e, x_1) = id = c(x_1, e),$$

then the morphism $\phi : \mathbf{CoB} \rightarrow \mathbf{Q}$ has a unitary extension $\phi_+ : \mathbf{CoB}_+ \rightarrow \mathbf{Q}$ sending the distinguished arity 0 element of the unitary operad of colored braids \mathbf{CoB}_+ to this object $e \in \mathbf{Ob} \mathbf{Q}(0)$.

PROOF. This result follows from the same arguments as Theorem 6.2.4. We just drop the consideration of associators from our verifications. \square

6.2.7. *The operadic representation of braided monoidal structures on categories.*

We can extend the observations of §6.1.9 to get an interpretation of the action of the operads $P = \mathbf{CoB}_+, \mathbf{PaB}_+$ on a category \mathcal{C} . We again use that such an action is encoded by a morphism $\phi : P \rightarrow \mathbf{End}_{\mathcal{C}}$ mapping the objects of our operad $p \in \mathbf{Ob} P(r)$ to multi-functors $f : \mathcal{C}^{\times r} \rightarrow \mathcal{C}$ and the morphisms of the operad to natural transformations.

In both cases, we can take the image of the object $\mu = \mu(x_1, x_2)$ under our morphism ϕ to get the tensor product operation $m(X_1, X_2) = X_1 \otimes X_2 : \mathcal{C} \times \mathcal{C} \rightarrow \mathcal{C}$ of a monoidal structure on \mathcal{C} (as in §6.1.9). The image of the unitary element of the operad gives a natural transformation $e : pt \rightarrow \mathcal{C}$ equivalent to a unit object $\mathbb{1} \in \mathcal{C}$ for this tensor product in \mathcal{C} , and we can take the image of the image of the braiding τ to get a natural isomorphism $c(X_1, X_2) : X_1 \otimes X_2 \xrightarrow{\cong} X_2 \otimes X_1$ making the tensor product braided commutative. In the parenthesized braid operad case, we take the image of the associator $\alpha \in \mathbf{Mor} \mathbf{PaB}(3)$ to get a natural isomorphism $a(X_1, X_2, X_3) : (X_1 \otimes X_2) \otimes X_3 \xrightarrow{\cong} X_1 \otimes (X_2 \otimes X_3)$ making the tensor product associative. In the colored braid operad case, we assume that the tensor product satisfies the associativity relation in the strict sense $(X_1 \otimes X_2) \otimes X_3 = X_1 \otimes (X_2 \otimes X_3)$ and we take $a(X_1, X_2, X_3) = id$ for the associator. Hence, we obtain that giving a morphism $\phi : \mathbf{PaB}_+ \rightarrow \mathbf{End}_{\mathcal{C}}$ is equivalent to giving a braided monoidal structure (in the sense of [122]) with strict unit relations but

general associativity isomorphisms in \mathcal{C} , while giving a morphism $\phi : \mathit{CoB}_+ \rightarrow \mathit{End}_{\mathcal{C}}$ is equivalent to giving a braided monoidal structure with both strict unit and strict associativity relations. The pentagon diagram of Figure 6.1 and the hexagon diagrams of Figure 6.6 are equivalent to the usual coherence axioms of braided monoidal categories (see [122]), and we have a similar correspondence for the coherence constraints associated with the unit object.

The constructions of this chapter can readily be adapted to get operads governing symmetric monoidal category structures with strict or general associativity isomorphisms. We then consider the operad in sets Γ_+ such that $\Gamma_+(r) = pt$, for all $r \in \mathbb{N}$ (the operad of commutative monoids), and the discrete operads in groupoids, which has the components of this operad as object sets. We get the operad governing symmetric monoidal category structures with strict associativity isomorphisms by performing the pullback of this operad along the morphism $\alpha : \Pi_+ \rightarrow \Gamma_+$, from the permutation operad Π_+ to Γ_+ , and the operad governing symmetric monoidal category structures with general associativity isomorphisms by performing the pullback along the morphism $\omega : \Omega_+ \rightarrow \Gamma_+$ from the magma operad Ω_+ to Γ_+ .

6.2.8. *Free braided monoidal categories.* The free algebra construction of §1.3.4 can be applied in the category of small categories, and, in the case $P = \mathit{CoB}_+, \mathit{PaB}_+$, this construction returns a free (strict, general) braided monoidal category $\mathbb{S}(P, \mathcal{X})$, which we naturally associate to any $\mathcal{X} \in \mathcal{Cat}$.

We focus on the case of a one-point set $\mathcal{X} = pt$. For the operad $P = \mathit{CoB}_+$, we obtain $\mathit{Ob} \mathbb{S}(\mathit{CoB}_+, pt) = \mathbb{N}$, and $\mathbb{S}(\mathit{CoB}_+, pt) = \coprod_{r \in \mathbb{N}} (\mathit{CoB}_+(r) \times pt^{\times r})_{\Sigma_r} = \coprod_{r \in \mathbb{N}} \mathit{CoB}_+(r)_{\Sigma_r}$ is identified with the disjoint union of the braid groups B_r , regarded as categories with a single object. The tensor product $\otimes : \mathbb{S}(\mathit{CoB}_+, pt) \times \mathbb{S}(\mathit{CoB}_+, pt) \rightarrow \mathbb{S}(\mathit{CoB}_+, pt)$ is given by the addition of non-negative integers at the object level, and by the direct sum of braids at the morphism level. We actually retrieve, with this operadic approach, the Joyal-Street construction of the free braided monoidal category in [93].

For the operad $P = \mathit{PaB}_+$, we have $\mathit{Ob} \mathbb{S}(\mathit{PaB}_+, pt) = \Omega(x)_+$, where we use the notation $\Omega(x)_+$ for a free magma on one variable x . The category $\mathbb{S}(\mathit{PaB}_+, pt)$ admits a decomposition $\mathbb{S}(\mathit{PaB}_+, pt) = \coprod_{r \in \mathbb{N}} (\mathit{PaB}_+(r) \times pt^{\times r})_{\Sigma_r} = \coprod_{r \in \mathbb{N}} \mathit{PaB}_+(r)_{\Sigma_r}$, whose r th summand $\mathit{PaB}_+(r)_{\Sigma_r}$ is identified with the full subcategory generated by monomials of weight r in the object set defined by the free magma $\Omega(x)_+$. For any pair of such monomials $p, q \in \Omega(x)_+$, we moreover have $\mathit{Mor}_{\mathbb{S}(\mathit{PaB}_+, pt)}(p, q) = B_r$. The tensor product associated to this category $\otimes : \mathbb{S}(\mathit{PaB}_+, pt) \times \mathbb{S}(\mathit{PaB}_+, pt) \rightarrow \mathbb{S}(\mathit{PaB}_+, pt)$ is given by the substitution operation $p(x, \dots, x) \otimes q(x, \dots, x) = \mu(p(x, \dots, x), q(x, \dots, x))$ at the object level, and again, by the direct sum of braids at the morphism level.

Bar-Natan's parenthesized braid category (see [13]) is identified with the Hopf groupoids $\mathbb{k}[\mathit{PaB}_+(r)_{\Sigma_r}]$ associated to these summands of the free braided monoidal category (we give more details on Hopf groupoid constructions in §9).

Part 2

Completions and Grothendieck-Teichmüller Groups

Hopf Algebras

The purpose of this chapter is to review the definition of the notion of a Hopf algebra and to recall classical structure results on these objects.

Briefly recall for the moment that a Hopf algebra is an object which includes both a counitary coalgebra and a unitary algebra structure, and an operation, called the antipode, which is a generalization of the classical inversion operation for groups. Hopf algebras equipped with a commutative algebra structure naturally occur in the framework of algebraic geometry, as function rings of affine group schemes (see for instance [1, 30]). Hopf algebras equipped with a cocommutative coalgebra structure notably occur in algebraic topology as the homology of connected H -spaces (see for instance [177, §III.8] for an introduction to this subject), and as the natural structure of the Steenrod algebra (see [164]). Hopf algebras equipped with a cocommutative coalgebra structure also occur in representation theory, as the dual objects of the commutative Hopf algebras considered in the study of affine group schemes, and as enveloping algebras of Lie algebras (we address the subject of Lie algebras in the second section of this chapter). In the next chapter, we also use complete cocommutative Hopf algebra structure to extend the rationalization of abelian groups to pro-nilpotent groups. We refer to this construction as the Malcev completion. Further fields of applications of commutative and cocommutative Hopf algebra structures include algebraic combinatorics (see the monographs [3, 4]), the Grothendieck-Galois theory (see for instance [168, §6] for a nice introduction to this subject, and [29] for a comprehensive account), and the Connes-Kreimer approach of renormalization theory in mathematical physics (see [42]).

The notion of a Hopf algebra makes also sense without assuming any commutativity property, for both the coalgebra and the algebra part of the structure, and significant examples of Hopf algebras which are neither cocommutative nor commutative occur in the theory of quantum groups (we refer to [47] for a short overview of this subject, or to reference books). In our applications however, we only deal with Hopf algebras which are cocommutative as coalgebras. Therefore, when we deal with a Hopf algebra, we generally assume that the coalgebra structure is cocommutative and we do not recall this convention, unless the precision is required by the context.

In the first section of the chapter (§7.1), we recall the precise definition of a Hopf algebra, and we give a reminder of basic examples of Hopf algebra structures. To be more specific, we check that the free $\mathbb{k}[G]$ associated to a group G inherits a Hopf algebra structure.

The second section (§7.2) is devoted to the connection between Lie algebras and Hopf algebras: we recall the definition of the enveloping algebra of a Lie algebra, and the statement of the theorems of Poincaré-Birkhoff-Witt and Milnor-Moore

(the classical structure theorems of the theory of Hopf algebras). The main outcome of these theorems is that the enveloping algebra functor defines an equivalence of categories between the category of Lie algebras and a category formed by (co-commutative) Hopf algebras satisfying an appropriate conilpotence condition.

In the third section (§7.3), we provide a comprehensive study of Hopf algebras in the category of complete filtered modules. These complete Hopf algebra structures give the required device for the Hopf algebra approach of the Malcev completion of groups, which we tackle in the next the chapter §8.

7.1. The notion of a Hopf algebra

This first section is introductory. Our purpose is to recall the general definition of a Hopf algebra and the definition of the Hopf algebra structure on a group algebra $\mathbb{k}[G]$.

In short, the notion of a Hopf algebra is defined by replacing sets, underlying the usual group structures, by coalgebras, and by using tensor structures instead of cartesian structures in the definition of the unit, product, and inversion operations. In the case of a group algebra $\mathbb{k}[G]$, we consider the natural coalgebra structure of §2.0.5, with the coproduct defined by the diagonal $\Delta[g] = [g] \otimes [g]$ on the elements of G , and the counit such that $\epsilon[g] = 1$, for any $g \in G$. The Hopf structure on $\mathbb{k}[G]$ is yielded by the structure operations attached to our group G . In the sequel, we generally assume that the underlying coalgebra of a Hopf algebra is cocommutative, and we therefore take this convention in our definition.

The definition of a Hopf algebra makes sense in the general setting of symmetric monoidal categories. Throughout this section, we generally start with abstract definitions, formulated in that framework, and we make explicit the application of the concepts in the case of a category of modules over a ground ring \mathbb{k} . The purpose of this abstract approach is to give a conceptual introduction to the main ideas of the theory and to prepare the ground for applications of Hopf algebras in other contexts than plain module categories.

In certain cases, we may still use point-wise formulas, directly transported from a module context, to specify morphisms in abstract categories. The idea is to interpret such formulas in terms of operations on abstract variables, so that our formulas actually represent combinations of morphisms produced by applying structure operations associated with the ambient category. For instance, we may use the expression $c(x \otimes y) = y \otimes x$ to refer to a symmetry isomorphism $c : M \otimes N \xrightarrow{\cong} N \otimes M$.

To start with, we review the definition of the notion of a counitary (cocommutative) coalgebra, which we introduced in §2.0.3 in the context of symmetric monoidal categories, and on which we base our approach for the definition of a Hopf algebra. In a second stage, before addressing Hopf algebras, we examine the definition of a bialgebra, which are monoid objects (algebras in the sense of §2.0) in the symmetric monoidal category of coalgebras.

7.1.1. *Counitary cocommutative coalgebras.* Briefly recall that a counitary cocommutative coalgebra (in a symmetric monoidal category) consists of an object C equipped with a counit $\epsilon : C \rightarrow \mathbb{1}$ (also referred to as the augmentation) and a coproduct $\Delta : C \rightarrow C \otimes C$ satisfying counit, coassociativity and cocommutativity relations (see §2.0.3).

In the module context, the augmentation $\epsilon : C \rightarrow \mathbb{k}$ assigns a scalar $\epsilon(x) \in \mathbb{k}$ to any element $x \in C$, and we represent the expansion of a coproduct $\Delta(x) \in C^{\otimes 2}$, $x \in C$, by an expression of the form $\Delta(x) = \sum_{(x)} x_{(1)} \otimes x_{(2)}$, where $x_{(1)}, x_{(2)} \in C$ denote the factors of this tensor in $C^{\otimes 2}$.

The coassociativity relation implies that all iterations of the coproduct towards a fixed codomain $C^{\otimes n}$ define the same morphism $\Delta^{(n)} : C \rightarrow C^{\otimes n}$, and we can naturally extend our notation of the coproduct to represent the expansion of the n -fold tensor $\Delta^{(n)}(x) \in C^{\otimes n}$ arising from any such iterated application of coproducts. Explicitly, we write $\Delta^{(n)}(x) = \sum_{(x)} x_{(1)} \otimes \cdots \otimes x_{(n)}$, for any $x \in C$. In this formalism the coassociativity relation reads:

$$\underbrace{\sum_{(x)} x_{(1)} \otimes x_{(2)} \otimes x_{(3)}}_{\Delta^{(3)}(x)} = \underbrace{\sum_{(x)} \Delta(x_{(1)}) \otimes x_{(2)}}_{\Delta \otimes id \cdot \Delta(x)} = \underbrace{\sum_{(x)} x_{(1)} \otimes \Delta(x_{(2)})}_{id \otimes \Delta \cdot \Delta(x)}.$$

The counit relations read

$$\sum_{(x)} \epsilon(x_{(2)}) \cdot x_{(1)} = \sum_{(x)} \epsilon(x_{(1)}) \cdot x_{(2)} = x,$$

and the cocommutativity relation reads

$$\sum_{(x)} x_{(2)} \otimes x_{(1)} = \sum_{(x)} x_{(1)} \otimes x_{(2)}.$$

The associativity implies that these relations have an obvious extension to multiple coproducts. In particular, we obtain from the cocommutativity relation that an n -fold coproduct $\Delta^{(n)}(x) \in C^{\otimes n}$ is left invariant under the action of any permutation $s \in \Sigma_n$ on $C^{\otimes n}$.

Recall that we use the notation $\mathcal{C}om_+^c$ for the category formed by the counitary cocommutative coalgebras with the structure preserving morphisms of the ground category as morphisms.

7.1.2. Tensor product of counitary cocommutative coalgebras. In §2.0.3, we observe that the tensor product of augmented cocommutative coalgebras inherits a counitary cocommutative coalgebra structure, so that augmented cocommutative coalgebras form a symmetric monoidal category, with unit, associativity and symmetry isomorphisms inherited from the ground category.

In the module context, the definition of the augmentation on a tensor product of coalgebras $C, D \in \mathcal{C}om_+^c$ reads

$$\epsilon(x \otimes y) = \epsilon(x) \cdot \epsilon(y),$$

and the definition of the coproduct reads

$$\Delta(x \otimes y) = \sum_{(x),(y)} (x_{(1)} \otimes y_{(1)}) \otimes (x_{(2)} \otimes y_{(2)}),$$

for any $x \in C$, $y \in D$, and where we adopt the convention of §7.1.1 for the notation of the coproduct of x (respectively, y) in C (respectively, D).

The ground ring \mathbb{k} , defining the unit object of our module category $\mathcal{M}od$, is equipped with the augmented cocommutative algebra structure such that $\epsilon(1) = 1$ and $\Delta(1) = 1 \otimes 1$.

7.1.3. *Unitary associative algebras.* In §2.0, we focused on the study of commutative structures. However, we mentioned that most of our constructions can be handled for associative (non-commutative) algebras.

To get the definition of a unitary associative algebra, we just drop the commutativity requirement from our definition. Thus, a unitary associative algebra in a (symmetric) monoidal category \mathcal{M} explicitly consists of an object $A \in \mathcal{M}$ equipped with a unit morphism $\eta : \mathbb{1} \rightarrow A$ and a product $\mu : A \otimes A \rightarrow A$ satisfying unit and associativity relations, expressed by the commutativity of the usual diagrams:

$$\begin{array}{ccc}
 A \otimes \mathbb{1} & \xrightarrow{id \otimes \eta} & A \otimes A & \xleftarrow{\eta \otimes id} & \mathbb{1} \otimes A, \\
 & \searrow \simeq & \downarrow \mu & & \swarrow \simeq \\
 & & A & &
 \end{array}, \quad
 \begin{array}{ccc}
 A \otimes A \otimes A & \xrightarrow{id \otimes \mu} & A \otimes A \\
 \mu \otimes id \downarrow & & \downarrow \mu \\
 A \otimes A & \xrightarrow{\mu} & A
 \end{array}.$$

In the module context, we use the standard notation $1 = \eta(1) \in A$ and $a_1 \cdot a_2 = \mu(a_1 \otimes a_2)$, for the unit element and the product of any associative algebra A . If necessary, then we adopt the convention of §2.0 to specify the algebra corresponding to a given unit (respectively, product) morphism by adding a subscript in our notation.

The morphisms of unitary associative algebras consist, as in the commutative case, of the morphisms of the ground category which preserve the unit and product morphisms defining our structure. We use the notation $\mathcal{A}s_+ = \mathcal{M}\mathcal{A}s_+$ for the category of ~~associativity~~ algebras in \mathcal{M} , with the base category added as prefix when necessary.

unitary associative

7.1.4. *Tensor product of unitary associative algebras.* The tensor product $A \otimes B$ of unitary associative algebra $A, B \in \mathcal{A}s_+$ inherits a unitary associative algebra structure given by the same definition as in the unitary commutative algebra case:

- the unit morphism $\eta_{A \otimes B}$ is defined by the composite $\mathbb{1} \xrightarrow{\simeq} \mathbb{1} \otimes \mathbb{1} \xrightarrow{\eta_A \otimes \eta_B} A \otimes B$ involving the unit isomorphism of the ground symmetric monoidal category \mathcal{M} .
- the product morphism $\mu_{A \otimes B}$ is given by the composite $A \otimes B \otimes A \otimes B \xrightarrow{(2\ 3)^*} A \otimes A \otimes B \otimes B \xrightarrow{\mu_A \otimes \mu_B} A \otimes B$, involving the symmetry isomorphism of \mathcal{M} .

The unit object of the ground symmetric monoidal category $\mathbb{1}$ inherits a canonical unitary associative algebra structure and represents a unit object for the tensor product of unitary associative algebras. The category of unitary associative algebras inherits unit, associativity and symmetry isomorphisms from the ground category as well, and forms a symmetric monoidal category therefore.

In the module context, the unit element of the tensor product $A \otimes B$ is given by the tensor product $1 \otimes 1$ of the unit elements attached to each factor A, B , and the definition of the product reads $(a_1 \otimes b_1) \cdot (a_2 \otimes b_2) = (a_1 \cdot a_2) \otimes (b_1 \cdot b_2)$, for any $a_1 \otimes b_2, a_2 \otimes b_2 \in A \otimes B$.

This symmetric monoidal structure is similar to the symmetric monoidal structure on unitary commutative algebras, handled in §2.0.2. However, we may observe that the tensor product of unitary associative algebras is not identified with the coproduct of the category (in contrast with a tensor product of unitary commutative algebras). To be specific, we have a commutation relation $(a \otimes 1) \cdot (1 \otimes b) = (a \cdot 1) \otimes (1 \cdot b) = a \otimes b = (1 \cdot a) \otimes (b \cdot 1) = (1 \otimes b) \cdot (a \otimes 1)$, between the image

of the elements of A and B in the tensor product $A \otimes B$, while such commutativity relations do not occur in coproducts when we work in the category of unitary associative algebras.

7.1.5. *Bialgebras.* We formally define a (cocommutative) bialgebra as a unitary associative algebra (in the sense of §7.1.3) in the symmetric monoidal category of counitary (cocommutative) coalgebras. Accordingly, in the general context of a symmetric monoidal category \mathcal{M} , a cocommutative bialgebra consists of an object $H \in \mathcal{M}$ equipped with:

- (a) a counitary cocommutative coalgebra structure, determined by a counit $\epsilon : H \rightarrow \mathbb{1}$ and a coproduct $\Delta : H \rightarrow H \otimes H$ satisfying the counit, coassociativity, and cocommutativity relations of §2.0.3,
- (b) together with a unit morphism $\eta : \mathbb{1} \rightarrow H$ and a product morphism $\mu : H \otimes H \rightarrow H$, both formed in the category of counitary cocommutative coalgebras, and satisfying the unit and associativity relations of §7.1.3 in that category.

Under our conventions for the notation of algebra categories, the category of bialgebras which we define in this paragraph is denoted by the expression $\mathcal{C}om_+^c \mathcal{A}s_+ = \mathcal{M} \mathcal{C}om_+^c \mathcal{A}s_+$. (We mark the base category as a prefix when this information is necessary, as usual.)

7.1.6. *The distribution relations underlying a bialgebra structure.* Since the category of counitary cocommutative coalgebras inherits its symmetric monoidal structure from the ground category, the unit and product morphisms defining the unitary associative algebra structure of our bialgebra can be formed in the ground category, and the requirement that these morphisms are morphisms of counitary cocommutative coalgebras amounts to the commutativity of the diagrams:

(a)
$$\begin{array}{ccc} \mathbb{1} & \xrightarrow{\eta} & H \\ & \searrow & \downarrow \epsilon \\ & & \mathbb{1} \end{array} = \begin{array}{ccc} \mathbb{1} & \xrightarrow{\eta} & H \\ \simeq \downarrow & & \downarrow \Delta \\ \mathbb{1} \otimes \mathbb{1} & \xrightarrow{\eta \otimes \eta} & H \otimes H \end{array}$$

(as regards the unit morphism),

(b) and
$$\begin{array}{ccc} H \otimes H & \xrightarrow{\mu} & H \\ \epsilon \otimes \epsilon \downarrow & & \downarrow \epsilon \\ \mathbb{1} \otimes \mathbb{1} & \xrightarrow{\simeq} & \mathbb{1} \end{array}, \quad \begin{array}{ccc} H \otimes H & \xrightarrow{\mu} & H \\ \Delta \otimes \Delta \downarrow & & \downarrow \Delta \\ H \otimes H \otimes H \otimes H & & \\ (2\ 3)^* \downarrow & & \\ H \otimes H \otimes H \otimes H & \xrightarrow{\mu \otimes \mu} & H \otimes H \end{array}$$

(as regards the product). In the module context, the commutation of these diagrams are equivalent to identities:

$$\begin{aligned} \epsilon(1) &= 1, & \Delta(1) &= 1 \otimes 1, \\ \text{and } \epsilon(a \cdot b) &= \epsilon(a) \cdot \epsilon(b), & \Delta(a \cdot b) &= \sum_{(a),(b)} a_{(1)} \cdot b_{(1)} \otimes a_{(2)} \cdot b_{(2)}, \end{aligned}$$

for any $a, b \in H$.

We just get these relations by unraveling the definition of the counitary cocommutative coalgebra structure on the unit object $\mathbb{1}$ ($\mathbb{1} = \mathbb{k}$ in the module context) and on the tensor product $H \otimes H$. We readily see that the distribution relation between the product and the coproduct amounts to $\Delta(a \cdot b) = \Delta(a) \cdot \Delta(b)$ by definition of the product of tensors in unitary associative algebras. More globally, the commutativity of diagrams (a-b) amounts to assuming that the counit $\epsilon : H \rightarrow \mathbb{1}$ and the coproduct $\Delta : H \rightarrow H \otimes H$ define morphisms of unitary associative algebras, with respect to the underlying unitary associative algebras structure of the bialgebra. We therefore obtain that:

PROPOSITION 7.1.7. *The bialgebras, initially defined as unitary associative algebras in the category of counitary cocommutative coalgebras in §7.1.5, can equivalently be defined as counitary cocommutative coalgebras in the category of unitary associative algebras, where we use the observations of §7.1.4 to provide the category of unitary associative algebras with a symmetric monoidal structure. \square*

Thus, under our conventions for the notation of categories, we have a category identity $Com_+^c As_+ = As_+ Com_+^c$.

We use the observation of this proposition in the next section when we define the Hopf algebra structure of enveloping algebras.

We generally use the expression of Hopf object to refer to any class of structured object formed in the symmetric monoidal category of counitary cocommutative coalgebras (see §2). When we deal with unitary associative algebra structures however, we prefer to reserve the expression of Hopf algebra for unitary associative algebras in counitary cocommutative coalgebras endowed with special features (in order to agree with the conventions of the literature) and we use the name of bialgebra in the general case.

7.1.8. Hopf algebras. We explicitly define a Hopf algebra H as a bialgebra in the sense of §7.1.5 equipped with:

- (a) morphisms $\sigma, \tau : H \rightarrow H$, formed in the ground category, which fit in a commutative diagram

$$\begin{array}{ccccc}
 H & \xrightarrow{\epsilon} & \mathbb{1} & \xrightarrow{\eta} & H \\
 \Delta \downarrow & & & & \uparrow \mu \\
 H \otimes H & \xrightarrow[\cong]{\sigma \otimes id} & & \xrightarrow[\cong]{id \otimes \tau} & H \otimes H
 \end{array}$$

involving the structure morphisms of our bialgebra.

This definition makes sense in any symmetric monoidal category, but we examine the particular case of Hopf algebras in modules with more details first, before tackling more elaborate examples in the next sections. In the module context, our relations, formalized by the commutativity of diagrams in (a), are equivalent to the equations

$$\sum_{(a)} \sigma(a_{(1)}) \cdot a_{(2)} \stackrel{(1)}{=} \epsilon(a) \cdot 1 \stackrel{(2)}{=} \sum_{(a)} a_{(1)} \cdot \tau(a_{(2)}) \tag{1} \tag{2}$$

in H , for any $a \in H$. In general, a morphism σ which fits in a relation of the form (1) is called a left antipode, and a morphism τ which fits in the symmetric relation (2) is called a right antipode.

We denote the category of Hopf algebras by the expression $\mathcal{HopfGrp}$. We do not use the following remark, but under our conventions regarding the notation of categories of structured objects in ~~/unitary cocommutative/~~algebras, this notation $\mathcal{HopfGrp}$ can be motivated by the observation that Hopf algebras, in the sense of our definition, are nothing but group objects in the category of ~~/unitary cocommutative/~~algebras (see [1, §A.5]).

/cσ
/cσ
/cσ

To complete the definition of a Hopf algebra, we check that:

PROPOSITION 7.1.9. *In general, if we assume that a bialgebra H is equipped with a left antipode $\sigma : H \rightarrow H$, then we have at most one right antipode on H which is necessarily equal to the left antipode as a morphism from H to H . If we symmetrically assume that a bialgebra H is equipped with a right antipode $\tau : H \rightarrow H$, then we have at most one left antipode on H which is also necessarily equal to the right antipode.*

Hence, in our definition of a Hopf algebra §7.1.8, the left and the right antipodes are necessarily equal $\sigma = \tau$, and are also unique. Furthermore any morphism of bialgebras $\phi : G \rightarrow H$, where G and H are Hopf algebras, automatically preserves antipodes.

PROOF. The result of this proposition holds in any symmetric monoidal category, but we prefer to give a proof in the module setting in order to exercise with our coproduct notation. The reformulation of our arguments in a general setting is the matter of a straightforward transcription.

Let H be any bialgebra. The proof of the first claims of the proposition reduce to the proof of an identity $\sigma(a) = \tau(a)$, for all $a \in H$, and for any given left and right antipodes $\sigma, \tau : H \rightarrow H$. To establish this relation, we perform different reductions of the expression

$$\mu^{(3)}(\sigma \otimes id \otimes \tau) \cdot \Delta^{(3)}(a) = \sum_{(a)} \sigma(a_{(1)}) \cdot a_{(2)} \cdot \tau(a_{(3)}),$$

/μ⁽³⁾

leading to $\sigma(a)$ in one case, and to $\tau(a)$ in the other case. For this purpose, we just observe that both the left and right antipode relations can be applied within our 3-fold coproduct $\Delta^{(3)}(a) = \Delta \otimes id \cdot \Delta(a) = id \otimes \Delta \cdot \Delta(a)$. By using counit and unit relations together with these antipode relations, we explicitly obtain:

$$\begin{aligned} \sum_{(a)} \sigma(a_{(1)}) \cdot a_{(2)} \cdot \tau(a_{(3)}) &= \sum_{(a)} \epsilon(a_{(1)}) \cdot 1 \cdot \tau(a_{(2)}) = \sum_{(a)} \epsilon(a_{(1)}) \cdot \tau(a_{(2)}) = \tau(a), \\ &= \sum_{(a)} \sigma(a_{(1)}) \cdot 1 \cdot \epsilon(a_{(2)}) = \sum_{(a)} \sigma(a_{(1)}) \cdot \epsilon(a_{(2)}) = \sigma(a), \end{aligned}$$

and these identities prove our claim $\sigma(a) = \tau(a)$.

The relation $\phi\sigma(a) = \tau\phi(a) = \sigma\phi(a)$, for a morphism $\phi : G \rightarrow H$, follows from the same argument line, by considering different reductions of the expression $(\phi\sigma \otimes \phi \otimes \tau\phi) \cdot \Delta^{(3)}(a) = \sum_{(a)} \phi\sigma(a_{(1)}) \cdot \phi(a_{(2)}) \cdot \tau\phi(a_{(3)})$. \square

Thus, in what follows, we use the name of antipode (without extra precision) to refer to the single morphism $\sigma = \tau$ defining both the left and the right antipode of a Hopf algebra. The result of Proposition 7.1.9 also motivates us to regard Hopf algebras as bialgebras endowed with special features (as alluded to before we introduce our definition), rather than bialgebras equipped with an additional

structure. In categorical terms, we regard the category of Hopf algebras $\mathcal{HopfGrp}$ as a full subcategory of the category of bialgebras.

This interpretation diminishes the inconsistency between the definition of a Hopf algebra and our convention to use the name Hopf as a qualifier for any category of structured object in the symmetric monoidal category of counitary cocommutative coalgebras. In fact, the terminology of Hopf algebra was originally used in algebraic topology for bialgebra structures, without any reference to antipodes, but in situations where antipodes automatically exist.

By elaborating on the arguments of Proposition 7.1.9, we also obtain that:

PROPOSITION 7.1.10. *In a Hopf algebra H , the antipode $\sigma : H \rightarrow H$ defines:*

- (a) *a morphism of counitary cocommutative coalgebras from H to H ;*
- (b) *and a morphism of unitary associative algebras from H to H^{op} , the unitary associative algebra obtained by changing the product of H into the transposite operation $\mu^{op} = \mu \cdot (1\ 2)^*$ (we also say that σ defines a antimorphism of unitary associative algebras from H to H).*

We check this proposition in the module context again. The transcription of our arguments in a general categorical setting reduces to a straightforward exercise as in the proof of Proposition 7.1.9. We see that the assertions of our proposition are equivalent to the relations of the following statement:

LEMMA 7.1.11.

- (a) *The antipode $\sigma(a)$ of any element $a \in H$ in a Hopf algebra H satisfies the identities*

$$\epsilon(\sigma(a)) = \epsilon(a) \quad \text{and} \quad \Delta\sigma(a) = \sum_{(a)} \sigma(a_{(2)}) \otimes \sigma(a_{(1)}),$$

with respect to the counit $\epsilon : H \rightarrow \mathbb{k}$ and the coproduct $\Delta : H \rightarrow H \otimes H$ of the counitary cocommutative coalgebra structure underlying H .

- (b) *The antipode also preserves the unit element $1 \in H$, in the sense that $\sigma(1) = 1$, and we have the formula*

$$\sigma(a \cdot b) = \sigma(b) \cdot \sigma(a),$$

for a product of elements $a, b \in H$.

PROOF. We establish the product relation first. We need the identity $\sigma = \tau$, established in Proposition 7.1.9, between the left and right antipodes of the Hopf algebra.

We readily see, as in the proof of Proposition 7.1.9, that, for any $a, b \in H$, the expression $\sum_{(a),(b)} \sigma(a_{(1)} \cdot b_{(1)}) \cdot a_{(2)} \cdot b_{(2)} \cdot \tau(b_{(3)}) \cdot \tau(a_{(3)})$, can either be reduced to $\sigma(a \cdot b)$, by using the right antipode relation for τ (together with the other structure relations of bialgebras) or to $\tau(b) \cdot \tau(a)$ by using the left antipode relation for σ (together with the distribution relation between the product and the coproduct of H). We therefore obtain $\sigma(a \cdot b) = \tau(b) \cdot \tau(a) = \sigma(b) \cdot \sigma(a)$.

We establish the coproduct relation $\Delta\sigma(a) = \sum_{(a)} \sigma(a_{(2)}) \otimes \sigma(a_{(1)})$ by similar arguments, by considering different reductions of the expression $\sum_{(a)} \Delta\sigma(a_{(1)}) \cdot \Delta(a_{(2)}) \cdot (1\ 2)^*(\tau \otimes \tau)\Delta(a_{(3)})$ leading to $\Delta\sigma(a)$ in one case, to $\sum_{(a)} \tau(a_{(2)}) \otimes \tau(a_{(1)})$ in the other case. We establish the augmentation relation $\epsilon\sigma(a) = \epsilon(a)$ by considering different reductions of the expression $\sum_{(a)} \epsilon\sigma(a_{(1)}) \cdot \epsilon(a_{(2)})$, and the unit relation

$\sigma(1) = 1$ is a direct consequence of the left antipode relation $\sigma(1) \cdot 1 = \epsilon(1) \cdot 1$ and of the identity $\epsilon(1) = 1$. \square

For the sake of completeness, we also check that:

PROPOSITION 7.1.12. *The antipode of a Hopf algebra satisfies the involution equation $\sigma^2 = id$ as long as we assume that the coproduct of a Hopf algebra is cocommutative.*

PROOF. We check this assertion in the module context again. The transcription of our arguments in a general categorical setting reduces to a straightforward exercise. We start with the expression $\sum_{(a)} \sigma(\sigma(a_{(1)})) \cdot \sigma(a_{(2)}) \cdot a_{(3)}$. On the one hand, by performing the left antipode relation on factors (2, 3) of the tensor product, we see that this expression reduces to $\sigma(\sigma(a))$. On the other hand, the already established coproduct identity $\Delta\sigma = \sigma \otimes \sigma \cdot \Delta$ (where we use the cocommutativity of the coproduct to drop the transposition) implies that we can also apply the left antipode relation on factors (1, 2) of our tensor product, which, in the final outcome, reduces to the simple expression of our element $a \in A$. We obtain as a result that $\sigma(\sigma(a)) = a$, for any $a \in A$, which is the claim of the proposition. \square

7.1.13. Monoid and group algebras. Recall that we use the notation $\mathbb{k}[X]$ for the free \mathbb{k} -module associated to a set X , and the notation $[x]$ for the basis element of this \mathbb{k} -module $\mathbb{k}[X]$ associated to any $x \in X$. In §2.0.3, we observed that $\mathbb{k}[X]$ inherits a canonical counitary cocommutative coalgebra structure, with a counit determined on basis elements by the formula $\epsilon[x] = 1$, and a coproduct determined by $\Delta[x] = [x] \otimes [x]$, for any $x \in X$.

In the case of an associative monoid $X = M$, we readily see that $\mathbb{k}[M]$ inherits an additional unitary associative algebra structure, with a unit $1 = [1]$ yielded by the unit of M , and a product induced by the product of M on basis elements, so that $[a] \cdot [b] = [a \cdot b]$, for any $a, b \in M$. Furthermore, we easily check that the relations of §7.1.6 are satisfied, so that our unit $\eta : \mathbb{k} \rightarrow \mathbb{k}[M]$ and product morphisms $\mu : \mathbb{k}[M] \otimes \mathbb{k}[M] \rightarrow \mathbb{k}[M]$ are morphisms of counitary cocommutative coalgebras. Hence, the free \mathbb{k} -module $\mathbb{k}[M]$ associated to a monoid M forms a bialgebra in the sense of the definition of §7.1.5.

In the case of a group $X = G$, we can check further that the mapping $\sigma : \mathbb{k}[G] \rightarrow \mathbb{k}[G]$ such that $\sigma[g] = [g^{-1}]$, for any $g \in G$, satisfies the equation of a left and right antipode on $\mathbb{k}[G]$. Hence, the free \mathbb{k} -module $\mathbb{k}[G]$ associated to a group G (the group algebra of G) forms an instance of a Hopf algebra, in the sense of the definition of §7.1.8.

7.1.14. Group like elements. Recall that the subset of group-like elements of a counitary cocommutative coalgebra C , denoted by $\mathbb{G}(C)$, is defined by:

$$\mathbb{G}(C) = \{c \in C \mid \epsilon(c) = 1, \Delta(c) = c \otimes c\}.$$

In §2.0.5, we observed that the mapping $\mathbb{G} : C \mapsto \mathbb{G}(C)$ defines a right adjoint of the free \mathbb{k} -module construction $\mathbb{k}[-] : X \mapsto \mathbb{k}[X]$, regarded as a functor $\mathbb{k}[-] : \mathit{Set} \rightarrow \mathit{Com}_+^c$ from the category of sets Set to the category of counitary cocommutative coalgebras in \mathbb{k} -modules $\mathit{Com}_+^c = \mathit{Mod} \mathit{Com}_+^c$. The unit of this adjunction is the morphism $\iota : X \rightarrow \mathbb{G} \mathbb{k}[X]$ yielded by the identity between the elements of X and the basis elements of the \mathbb{k} -module $\mathbb{k}[X]$ which are group-like by definition of our counitary cocommutative coalgebra structure on $C = \mathbb{k}[X]$. The adjunction

augmentation is the morphism $\rho : \mathbb{k}[\mathbb{G}(C)] \rightarrow C$ induced by the inclusion $\mathbb{G}(C) \subset C$ on the basis elements of the free \mathbb{k} -module $\mathbb{k}[X]$ with $X = \mathbb{G}(C)$.

In the context of groups and Hopf algebras, we obtain the following results:

PROPOSITION 7.1.15. *The set of group-like elements $\mathbb{G}(H)$ in a Hopf algebra H satisfies the following belonging relations:*

$$1 \in \mathbb{G}(H), \quad g, h \in \mathbb{G}(H) \Rightarrow g \cdot h \in \mathbb{G}(H), \quad \text{and} \quad g \in \mathbb{G}(H) \Rightarrow \sigma(g) \in \mathbb{G}(H).$$

Furthermore, for a group-like element $g \in \mathbb{G}(H)$, the antipode relations imply:

$$g \cdot \sigma(g) = \sigma(g) \cdot g = 1.$$

The set of group-like elements $\mathbb{G}(H)$ of a Hopf algebra H consequently inherits a group structure with the multiplication $\mu : \mathbb{G}(H) \times \mathbb{G}(H) \rightarrow \mathbb{G}(H)$ induced by the product of our Hopf algebra.

PROOF. The axioms of bialgebras include the relations $\epsilon(1) = 1$, $\Delta(1) = 1 \otimes 1$, which are equivalent to the requirement that the unit element of H is group-like in the sense of our definition. Hence, we have $1 \in \mathbb{G}(H)$.

For a product of group-like elements $g, h \in H$, the axioms of §7.1.6 imply the relations $\epsilon(g \cdot h) = \epsilon(g) \cdot \epsilon(h) = 1 \cdot 1 = 1$ and $\Delta(g \cdot h) = \Delta(g) \cdot \Delta(h) = (g \otimes g) \cdot (h \otimes h) = (g \cdot h) \otimes (g \otimes h)$. Hence, we have $g, h \in \mathbb{G}(H) \Rightarrow g \cdot h \in \mathbb{G}(H)$.

For the antipode $\sigma(g) \in H$ of a group-like element $g \in \mathbb{G}(H)$, the identities established in Lemma 7.1.11 imply $\epsilon\sigma(g) = \epsilon(g) = 1$ and $\Delta\sigma(g) = (1 \ 2)^*(\sigma \otimes \sigma)\Delta(g) = \sigma(g) \otimes \sigma(g)$. Hence, we have $g \in \mathbb{G}(H) \Rightarrow \sigma(g) \in \mathbb{G}(H)$.

The identities $g \cdot \sigma(g) = \sigma(g) \cdot g = 1$ are a formal consequence of the application of the antipode relation when we assume $\epsilon(g) = 1 \Rightarrow \eta\epsilon(g) = 1$ and $\Delta(g) = g \otimes g$. This observation completes our verifications. \square

PROPOSITION 7.1.16. *The functor $\mathbb{G} : \mathcal{H}opf\mathcal{G}rp \rightarrow \mathcal{G}rp$ obtained by the construction of Proposition 7.1.15 is also right adjoint to the group algebra functor $\mathbb{k}[-] : \mathcal{G}rp \rightarrow \mathcal{H}opf\mathcal{G}rp$, from groups to Hopf algebras.*

PROOF. We easily see that the unit and augmentation of the adjunction $\mathbb{k}[-] : \mathcal{G}rp \rightleftarrows \mathcal{C}om_+^c : \mathbb{G}$, defined at the set and counitary cocommutative coalgebra level in §2.0.5, preserve the additional unit and product structures when we deal with groups and Hopf algebras. Therefore our functors still form an adjoint pair groups and Hopf algebras $\mathbb{k}[-] : \mathcal{G}rp \rightleftarrows \mathcal{H}opf\mathcal{G}rp : \mathbb{G}$. \square

7.2. Lie algebras and Hopf algebras

In this second section, we provide a survey of the relationship between Lie algebras and Hopf algebras. Lie algebras arose in the mathematical literature as infinitesimal versions of group structures. The tangent space of a Lie group (a manifold equipped with a group structure) is a fundamental instance of Lie algebra. The classical third theorem of Sophus Lie asserts that any finite dimensional real Lie algebra can be integrated into a Lie group structure, and hence occurs as such a tangent space.

The relationship, which we aim to review in this section, is an algebraic analogue of this correspondence. The main device for this study is the enveloping algebra functor, of which we recall the formal definition. The Milnor-Moore Theorem precisely implies that the enveloping algebra functor induces an equivalence of

categories between the category of Lie algebras and a subcategory of locally conilpotent Hopf algebras (see §7.2.15). Besides the Milnor-Moore Theorem, we recall the statement of the Poincaré-Birkhoff-Witt Theorem as a fundamental structure result about enveloping algebras, and we give the statement of a general structure theorem for locally conilpotent Hopf algebras which we use in our proofs.

The first definitions of this section makes sense over any additive base symmetric monoidal category \mathcal{M} . In addition to this basic requirements, we prefer to assume, all through this section, that the morphism sets of \mathcal{M} are uniquely divisible as abelian groups, and hence form \mathbb{Q} -modules. To coin this situation, we say that we work in a \mathbb{Q} -additive symmetric monoidal category. In the case of a module category $\mathcal{M} = \text{Mod}$, this requirement amounts to assuming that the ground ring \mathbb{k} satisfies $\mathbb{Q} \subset \mathbb{k}$. If we do not take this assumption, then we have to distinguish several variants of the notion of a Lie algebra.

In a second stage, we perform colimit constructions, and we therefore assume that \mathcal{M} is equipped with arbitrary colimits. Then we also assume that the tensor product satisfies the colimit preservation requirement of §0.9.

The existence of kernels is not needed until we introduce the primitive element functor in §7.2.11. To simplify our exposition, we will assume from that moment on that kernels exist in our base category, and we establish our structure theorems in that setting. Nevertheless, the careful reader may observe that our argument lines work as soon as we have kernels of idempotent morphisms, so that both the Poincaré-Birkhoff-Witt Theorem and the Milnor-Moore Theorem hold in that setting.

The \mathbb{Q} -additive category requirement amounts to assuming that our category \mathcal{M} is canonically enriched over the \mathbb{Q} -modules $\text{Mod} = \text{Mod}_{\mathbb{Q}}$, with the morphism sets $\text{Mor}_{\mathcal{M}}(-, -)$ as hom-objects $\text{Hom}_{\mathcal{M}}(-, -)$. In good cases, the existence of this \mathbb{Q} -additive structure implies that the category is equipped with an external tensor product $\otimes : \text{Mod} \times \mathcal{M} \rightarrow \mathcal{M}$ such that $\text{Mor}_{\mathcal{M}}(K \otimes M, N) = \text{Mor}_{\text{Mod}}(K, \text{Hom}_{\mathcal{M}}(M, N))$ for each $K \in \text{Mod}$, and all $M, N \in \mathcal{M}$. By adjunction, we readily see that we have unit, associativity and symmetry relations associated to any combination of this tensor product $\otimes : \text{Mod} \times \mathcal{M} \rightarrow \mathcal{M}$ with the internal tensor product of Mod and \mathcal{M} . In [60], we observe that the existence of this structure amounts to assuming that we have symmetric monoidal functor $\eta : \text{Mod} \rightarrow \mathcal{M}$, mapping any \mathbb{Q} -module $K \in \text{Mod}$ to the tensor product $K \otimes \mathbb{1}$ with the unit object $\mathbb{1}$ in our symmetric monoidal category \mathcal{M} . In §7.2.3, we use such structures to relate a general definition of a Lie algebra with an operadic approach.

Throughout this section, we still use the convention to specify general morphisms by point-wise formulas, directly transported from a module context, and which we can interpret as morphism combinations produced by the application of structure operations of the ambient category (see our explanations in the introduction of the previous section). In our survey, we formulate all definitions in an abstract setting, and we make their applications explicit in the module context too. The immediate purpose of this abstract approach is again to give an conceptual introduction to the main ideas of the theory, in order to be prepared for applications in other contexts than the plain module categories. To begin with, we review the definition of a Lie algebra.

7.2.1. *Lie algebras.* In §1.3.1, we recall the definition of a Lie algebra as an instance of a category of algebras associated to an operad *Lie*.

In the context of a \mathbb{Q} -additive symmetric monoidal category \mathcal{M} , we define a Lie algebra as an object $\mathfrak{g} \in \mathcal{M}$ equipped with a morphism $\lambda : \mathfrak{g} \otimes \mathfrak{g} \rightarrow \mathfrak{g}$, called the Lie bracket, which satisfies the antisymmetry relation $\lambda \cdot (id + (1\ 2))^* = 0$, and a 3-fold tensor relation $\lambda(\lambda, 1) \cdot (id + (1\ 2\ 3) + (1\ 2\ 3)^2)^* = 0$, called the Jacobi relation. In these formulas, we use the notation σ^* for the action of the transposition $\sigma = (1\ 2) \in \Sigma_2$ and of the cycle $\sigma = (1\ 2\ 3) \in \Sigma_3$ on tensor powers $\mathfrak{g}^{\otimes n}$.

In the module context, we write $[x_1, x_2] \in \mathfrak{g}$ for the image of elements $x_1, x_2 \in \mathfrak{g}$ under the Lie bracket $\lambda : \mathfrak{g} \otimes \mathfrak{g} \rightarrow \mathfrak{g}$. The antisymmetry relation reads $[x_1, x_2] + [x_2, x_1] = 0$, and the Jacobi relation reads

$$[[x_1, x_2], x_3] + [[x_2, x_3], x_1] + [[x_3, x_1], x_2] = 0,$$

for $x_1, x_2, x_3 \in \mathfrak{g}$.

We denote the category of Lie algebras by $\mathcal{L}ie$. We naturally define a morphism of Lie algebras as a morphism of the base category preserving the structure (the Lie bracket) of our Lie algebras. As usual, we just specify the ambient symmetric monoidal category \mathcal{M} in our notation $\mathcal{L}ie = \mathcal{M}\mathcal{L}ie$ when this information is necessary.

7.2.2. Remarks. In the standard definition of a Lie algebra, we assume the vanishing relation $[x, x] = 0$, for $x \in \mathfrak{g}$, instead of the antisymmetry relation. In §8.2.3, where we give a short introduction to Lie algebras over the integers, we will take this vanishing relation $[x, x] = 0$ in our definition. But, this relation is equivalent to the symmetry relation, and give the same notion of Lie algebra, as soon as 2 are invertible in the the ground ring, and hence, under our assumption that the ground ring satisfies $\mathbb{Q} \subset \mathbb{k}$.

Further subtleties occur in other instances of symmetric monoidal categories. Notably, in the context of graded modules, where we use the symmetric monoidal structure of §4.4, the antisymmetry relation reads $[x_1, x_2] + \pm[x_2, x_1] = 0$, with an extra sign arising from the permutation of the elements $x_1, x_2 \in \mathfrak{g}$ (see §0.2, §4.4.1), and we do not necessarily assume that the Lie bracket $[x, x]$ of a homogeneous element of odd degree vanishes. But the vanishing relation $[x, x] = 0$ for the homogeneous elements of even degree, as well as $[[x, x], x] = 0$ for the homogeneous elements of odd degree, is usually taken as part of the definition of graded Lie algebra in the literature. These requirements are automatically fulfilled, as consequences of the (graded) antisymmetry and Jacobi relations, when 2 and 3 are invertible in the the ground ring, and hence, under our assumption that the ground ring satisfies $\mathbb{Q} \subset \mathbb{k}$.

7.2.3. Relationship with the operadic definition and free Lie algebras. The definition of §7.2.1 agrees with the definition of the structure of an algebra over the Lie operad in §1.3.1.

In §1.3.1, we explain that the definition of such a structure, in terms of a morphism $\lambda : \mathfrak{g} \otimes \mathfrak{g} \rightarrow \mathfrak{g}$ satisfying relations, amounts to giving an operad morphism $\phi : \mathcal{L}ie \rightarrow \mathbf{End}_{\mathfrak{g}}$, where $\mathcal{L}ie$ is our notation for the Lie operad, and $\mathbf{End}_{\mathfrak{g}}$ is the endomorphism operad associated to the object $\mathfrak{g} \in \mathcal{M}$, defined by the hom-object $\mathbf{End}_{\mathfrak{g}}(r) = \mathbf{Hom}_{\mathcal{M}}(\mathfrak{g}^{\otimes r}, \mathfrak{g})$ in each arity $r \in \mathbb{N}$. In this correspondence, we use the observation, made in the introduction of this section, that our symmetric monoidal category \mathcal{M} is naturally enriched over the base category of \mathbb{Q} -modules (where the Lie operad is defined).

The interpretation of Lie algebras in terms of algebras over operads implies that the category of Lie algebras inherits free objects, which admit an expansion of the form $\mathbb{L}(M) = \bigoplus_{r=0}^{\infty} (\mathcal{L}ie(r) \otimes M^{\otimes r})_{\Sigma_r}$. Recall that the expression $(-)\Sigma_r$ in this

expansion refers to the application of a coinvariant functor, used to coequalize the right action of permutations on the tensor power $M^{\otimes r}$ with their left action on the term $Lie(r)$ of the Lie operad (see §§1.3.2-1.3.5). In the sequel, we refer to the terms of this expansion $\mathbb{L}_r(M) = (Lie(r) \otimes M^{\otimes r})_{\Sigma_r}$ as the components of homogeneous weight of the free Lie algebra.

In §1.3.2, we define the Lie operad Lie in a base category of modules over a ring. In the setting of a \mathbb{Q} -additive symmetric monoidal category \mathcal{M} , we can use the external tensor product operation $\otimes : Mod \times \mathcal{M} \rightarrow \mathcal{M}$ to form the summands $(Lie(r) \otimes M^{\otimes r})_{\Sigma_r}$ of the free Lie algebra, with $Lie(r) \in Mod$ and $M \in \mathcal{M}$.

In the literature, the free Lie algebra is usually defined as a quotient of a free magma (see for instance [32, II.2.2], or [147, §0.2]). This construction parallels the definition of the Lie operad by generators and relation. (Magmas, as we observed in §6.1, are identified with structures associated to free operads.)

The free Lie algebra $\mathbb{L}(M)$ intuitively consists of Lie monomials on generating variables $x \in M$, where a Lie monomial refers to a formal operadic composite of Lie brackets quotiented by the antisymmetry and Jacobi relations. The Lie bracket on $\mathbb{L}(M)$ is intuitively defined by the obvious substitution operation on Lie monomials. The homogeneous component $\mathbb{L}_r(M)$, for any $r \in \mathbb{N}$, consists of Lie monomials on r variables. The Lie bracket preserves the weight grading in the sense that $[\mathbb{L}_s(M), \mathbb{L}_t(M)] \subset \mathbb{L}_{s+t}(M)$. (We go back to the notion of weight grading in the next section.)

In §1.2.11, we mention that the Lie operad has an intricate symmetric structure. The structure theorems of Hopf algebras imply that the free Lie algebra functor has a more effective realization in terms of a retract of the tensor algebras, and we rather use this approach when we have to deal with free Lie algebras. We review the definition of the (non-unitary) tensor and symmetric algebras before tackling this subject.

7.2.4. The tensor algebra and the symmetric algebra. The (unitary) tensor algebra $\mathbb{T}(M)$ associated to an object $M \in \mathcal{M}$ in our base category \mathcal{M} is explicitly defined by the sum $\mathbb{T}(M) = \bigoplus_{r=0}^{\infty} M^{\otimes r}$, where we form the tensor powers of our object $M^{\otimes r}$ by using the tensor product operation of the base category $\otimes : \mathcal{M} \times \mathcal{M} \rightarrow \mathcal{M}$. In the sequel, we refer to the summands of this expansion $\mathbb{T}_r(M) = M^{\otimes r}$ as the components of homogeneous weight of the tensor algebra.

The (unitary) symmetric algebra $\mathbb{S}(M)$ is explicitly defined by the sum $\mathbb{S}(M) = \bigoplus_{r=0}^{\infty} (M^{\otimes r})_{\Sigma_r}$, where we apply the coinvariant functor $(-)_{\Sigma_r}$ to make the action of permutations $\sigma \in \Sigma_r$ on the tensor power $M^{\otimes r}$ equal to the identity morphism. In the module context, these coinvariance relations read $x_{\sigma(1)} \otimes \cdots \otimes x_{\sigma(r)} \equiv x_1 \otimes \cdots \otimes x_r$ for all $x_1 \otimes \cdots \otimes x_r \in M^{\otimes r}$, and each $\sigma \in \Sigma_r$. The summands $\mathbb{S}_r(M) = (M^{\otimes r})_{\Sigma_r}$ define the components of homogeneous weight of the symmetric algebra.

The tensor algebra inherits a unit $\eta : \mathbb{1} \rightarrow \mathbb{T}(M)$, given by the identity between the unit object $\mathbb{1}$ and the summand $M^{\otimes 0} = \mathbb{1}$ of weight $r = 0$ in $\mathbb{T}(M)$, as well as a product $\mu : \mathbb{T}(M) \otimes \mathbb{T}(M) \rightarrow \mathbb{T}(M)$, defined termwise by the concatenation operation $M^{\otimes s} \otimes M^{\otimes t} \xrightarrow{\cong} M^{\otimes s+t}$, so that $\mathbb{T}(M)$ forms a unitary associative algebra. The symmetric algebra inherits a similarly defined unit $\eta : \mathbb{1} \rightarrow \mathbb{S}(M)$, as well as a product $\mu : \mathbb{S}(M) \otimes \mathbb{S}(M) \rightarrow \mathbb{S}(M)$, which is given termwise by the morphism $(M^{\otimes s})_{\Sigma_s} \otimes (M^{\otimes t})_{\Sigma_t} \rightarrow (M^{\otimes s+t})_{\Sigma_{s+t}}$ induced by the concatenation operation of the

tensor algebra. The coinvariant quotient implies that this product operation becomes commutative on the symmetric algebra, and hence, the object $\mathbb{S}(M)$ actually forms a unitary commutative algebra.

In the tensor algebra case, we have a canonical embedding $\iota : M \rightarrow \mathbb{T}(M)$, given by the identity between the object M and the summand $M^{\otimes 1} = M$ of order $r = 1$ in $\mathbb{T}(M)$. In the symmetric algebra case, we have a similarly defined embedding $\iota : M \rightarrow \mathbb{S}(M)$, given by the identity between the object M and the summand $(M^{\otimes 1})_{\Sigma_1} = M$ in $\mathbb{S}(M)$.

In §1.3.5, we already briefly recalled the definition of the tensor and symmetric algebras (in the non-unitary context) as instances of free algebras associated to operads. This free algebra interpretation of the tensor and symmetric algebras reads as follows:

PROPOSITION 7.2.5.

- (a) *The tensor algebra functor $\mathbb{T} : \mathcal{M} \rightarrow \mathcal{A}s_+$ is left adjoint to the forgetful functor $\omega : \mathcal{A}s_+ \rightarrow \mathcal{M}$ from the category of unitary associative algebras $\mathcal{A}s_+$ to the base category \mathcal{M} . The embedding $\iota : M \rightarrow \mathbb{T}(M)$ represents the unit of this adjunction relation.*
- (b) *The symmetric algebra functor $\mathbb{S} : \mathcal{M} \rightarrow \mathcal{C}om_+$ is left adjoint to the forgetful functor $\omega : \mathcal{C}om_+ \rightarrow \mathcal{M}$ from the category of unitary commutative algebras $\mathcal{A}s_+$ to the base category \mathcal{M} . The embedding $\iota : M \rightarrow \mathbb{S}(M)$ also represents the unit of this adjunction relation.*

EXPLANATIONS. In §§1.3.3-1.3.4, we explained that the assertions of this proposition have an equivalent formulation in terms of universal properties. In the case of the tensor algebra $R = \mathbb{T}(M)$ (respectively, in the case of the symmetric algebra $R = \mathbb{S}(M)$), we explicitly obtain that any morphism $f : M \rightarrow A$ towards a unitary associative (respectively, commutative) algebra A admits a unique factorization

$$\begin{array}{ccc} M & \xrightarrow{f} & A \\ & \searrow \iota & \nearrow \phi_f \\ & R & \end{array}$$

such that ϕ_f is a morphism of unitary associative (respectively, commutative) algebras.

The image of a tensor $x_1 \otimes \cdots \otimes x_r \in M^{\otimes r}$ in the tensor algebra $\mathbb{T}(M)$ is denoted by $x_1 \cdot \cdots \cdot x_r \in \mathbb{T}(M)$ (whenever the notion of elements makes sense), because by identifying the object M with a summand of $\mathbb{T}(M)$, we obtain that this tensor represents the product of the elements $x_1, \dots, x_r \in M$ in $\mathbb{T}(M)$. We adopt similar conventions for the symmetric algebra. In this case, we have the identity $x_{\sigma(1)} \cdot \cdots \cdot x_{\sigma(r)} = x_1 \cdot \cdots \cdot x_r$, arising from the coinvariant quotient, and which also reflects the commutativity of the product in $\mathbb{S}(M)$. The product of the tensor algebra is given by the concatenation operation $(x_1 \cdot \cdots \cdot x_s) \cdot (y_1 \cdot \cdots \cdot y_t) = (x_1 \cdot \cdots \cdot x_s \cdot y_1 \cdot \cdots \cdot y_t)$, and similarly in the symmetric algebra case.

The extension of a module morphism $f : M \rightarrow A$ to the tensor (respectively, symmetric) algebra is explicitly defined by the formula $\phi_f(x_1 \cdot \cdots \cdot x_r) = f(x_1) \cdot \cdots \cdot f(x_r)$ for any tensor (respectively, symmetric) algebra monomial $x_1 \cdot \cdots \cdot x_r \in R$ where we form the product of the images of the elements $x_1, \dots, x_r \in M$ in the associative (respectively, commutative) algebra A . \square

We use the statement of Proposition 7.2.5 to establish the following structure result:

PROPOSITION 7.2.6. *The tensor algebra $R = \mathbb{T}(M)$ (respectively, the symmetric algebra $R = \mathbb{S}(M)$) inherits a Hopf algebra structure such that:*

- *the augmentation $\epsilon : R \rightarrow \mathbb{1}$ is the morphism of unitary associative (respectively, commutative) algebras associated with the zero morphism $\epsilon(x) = 0$ from M to the unit object $\mathbb{1}$;*
- *the coproduct $\Delta : R \rightarrow R \otimes R$ is the morphism of unitary associative (respectively, commutative) algebras defined, on $M \subset R$, by the formula $\Delta(x) = x \otimes 1 + 1 \otimes x$;*
- *the antipode $\Delta : R \rightarrow R$ is the anti-morphism of unitary associative (respectively, commutative) algebras defined, on $M \subset R$, by the opposite of the identity map $\sigma(x) = -x$.*

In an abstract categorical setting, we regard our point-wise formulas as an algebraic combination of morphisms involving the structure operations of the ambient category (as explained in the introduction of this section).

EXPLANATIONS. In the module context, we can apply the formula given in the proof of Proposition 7.2.5 to determine the image of any monomial $x_1 \cdots x_r \in R$ under our structure morphisms. For the augmentation, we obtain $\epsilon(x_1 \cdots x_r) = \epsilon(x_1) \cdots \epsilon(x_r) = 0$ as soon as $r > 0$. For the coproduct, we get the expression:

$$\begin{aligned} \Delta(x_1 \cdots x_r) &= \underbrace{(x_1 \otimes 1 + 1 \otimes x_1)}_{\Delta(x_1)} \cdots \underbrace{(x_r \otimes 1 + 1 \otimes x_r)}_{\Delta(x_r)} \\ &= \sum_{\substack{\{i_1 < \cdots < i_s\} \amalg \{j_1 < \cdots < j_t\} \\ = \{1 < \cdots < r\}}} (x_{i_1} \cdots x_{i_s}) \otimes (x_{j_1} \cdots x_{j_t}). \end{aligned}$$

For the antipode, we get $\sigma(x_1 \cdots x_r) = \sigma(x_r) \cdots \sigma(x_1) = (-1)^r \cdot (x_r \cdots x_1)$.

The proof of the structure relations of Hopf algebras reduces to straightforward verifications, which are also immediate once we observe that the uniqueness claim in the definition of morphisms on tensor (respectively, symmetric) algebras enables us to reduce these verifications to the case of generators. \square

7.2.7. *The adjunction between Lie and associative algebras.* Let A be any (unitary) associative algebra. One can readily check that the commutator $[a_1, a_2] = a_1 a_2 - a_2 a_1$ satisfies the antisymmetry and Jacobi relation of a Lie bracket, and hence provides A with a natural Lie algebra structure.

In §1.3.9, we interpret (a non-unitary version of) this correspondence as an instance of a restriction functor $\iota^* : A \mapsto \iota^* A$, associated to an operad morphism from the Lie operad to the (non-unitary) associative operad. This interpretation works same in the unitary context. In the case of the tensor algebra, the existence of this structure implies that, for any object $M \in \mathcal{M}$, we have a natural morphism of Lie algebras $\iota : \mathbb{L}(M) \rightarrow \mathbb{T}(M)$ fitting in a factorization

$$\begin{array}{ccc} M & \xrightarrow{\quad} & \mathbb{T}(M) \\ & \searrow & \nearrow \iota \\ & & \mathbb{L}(M) \end{array}$$

of the canonical embedding $M \hookrightarrow \mathbb{T}(M)$. In the operadic approach, we have $\mathbb{L}(M) = \bigoplus_{r=0}^{\infty} (\text{Lie}(r) \otimes M^{\otimes r})_{\Sigma_r}$ (see §1.3.5, §7.2.3), $\mathbb{T}(M) = \bigoplus_{r=0}^{\infty} (\text{As}_+(r) \otimes M^{\otimes r})_{\Sigma_r}$ (see §1.3.5), and our free algebra morphism is the natural transformation induced by the morphisms $\iota : \text{Lie}(r) \rightarrow \text{As}_+(r)$ at the operad level.

Intuitively, the morphism $\iota : \mathbb{L}(M) \rightarrow \mathbb{T}(M)$ maps the Lie monomials, which represent the elements of the free Lie algebra, into commutators in the tensor algebra. From this representation, we retrieve that the morphism $\iota : \mathbb{L}(M) \rightarrow \mathbb{T}(M)$ preserves the weight grading of our free algebras and splits as a sum of homogeneous components $\iota_r : \mathbb{L}_r(M) \rightarrow \mathbb{T}_r(M)$.

In Proposition 1.3.8, we give a general construction of extension functors on categories of algebras associated to operads. These extension functors are left adjoint to the restriction functors associated to operad morphisms. In the case of the Lie operad and the associative operad, the application of our construction returns a functor $\iota_! : \mathcal{L}ie \rightarrow \mathcal{A}s_+$ which is left adjoint to our explicitly defined restriction functor $\iota^* : \mathcal{A}s_+ \rightarrow \mathcal{L}ie$. The image of a Lie algebra \mathfrak{g} under this extension functor $\iota_! : \mathcal{L}ie \rightarrow \mathcal{A}s_+$ is usually called the enveloping algebra of \mathfrak{g} , and is denoted by $\iota_! \mathfrak{g} = \mathbb{U}(\mathfrak{g})$. The enveloping algebra of a Lie algebra is endowed with a Lie algebra a morphism $\iota : \mathfrak{g} \rightarrow \mathbb{U}(\mathfrak{g})$ which represents the unit of our adjunction.

In the approach of Proposition 1.3.8, the image of a Lie algebra under the extension functor $\iota_! \mathfrak{g} = \mathbb{U}(\mathfrak{g})$, is defined by a reflexive coequalizer of free algebras of the form:

$$\begin{array}{c} \begin{array}{ccc} & s_0 & \\ & \curvearrowright & \\ \mathbb{T}(\mathbb{L}(\mathfrak{g})) & \begin{array}{c} \xrightarrow{d_0} \\ \xrightarrow{d_1} \end{array} & \mathbb{T}(\mathfrak{g}) \end{array} \begin{array}{c} \xrightarrow{\epsilon} \\ \xrightarrow{\epsilon} \end{array} \mathbb{U}(\mathfrak{g}) . \end{array}$$

The morphism $\epsilon : \mathbb{T}(\mathfrak{g}) \rightarrow \mathbb{U}(\mathfrak{g})$ occurring in this coequalizer is identified with the morphism of associative algebras induced by the canonical morphism $\iota : \mathfrak{g} \rightarrow \mathbb{U}(\mathfrak{g})$ underlying the enveloping algebra. This coequalizer construction differs from the classical definition of the enveloping algebra, and which we will review in the next paragraph.

Before explaining the classical approach, we examine some applications of the general definition of our extension functor $\iota_! : \mathcal{L}ie \rightarrow \mathcal{A}s_+$ in the case of free Lie algebras. By composition of adjunction relations, we have in this case $\iota_! \mathbb{L}(M) = \mathbb{U} \mathbb{L}(M) = \mathbb{T}(M)$. Furthermore, we readily see that the previously considered morphism $\iota : \mathbb{L}(M) \rightarrow \mathbb{T}(M)$, defined by using the definition of free Lie algebras, is identified with the canonical Lie algebra morphism $\iota : \mathbb{L}(M) \rightarrow \mathbb{U} \mathbb{L}(M)$ attached with the enveloping algebra. For our purpose, we record the following observation:

PROPOSITION 7.2.8. *The morphism $\iota : \mathbb{L}(M) \rightarrow \mathbb{T}(M)$ admits a retraction $\rho : \mathbb{T}(M) \rightarrow \mathbb{L}(M)$, such that:*

$$\rho(x_1 \cdots x_r) = \frac{1}{r} \cdot [\cdots [[x_1, x_2], x_3], \dots, x_r],$$

for any tensor monomials $x_1 \cdots x_r \in \mathbb{T}_r(M)$, and all $r > 0$.

PROOF. We borrow our argument from [145, §B.2, Lemma 2.2]. We establish the proposition within a base category of modules. The general case of our assertion can then be deduced from the functoriality of the construction with respect to the underlying symmetric monoidal category. We use that the mapping $\Delta : \mathbb{L}(M) \rightarrow \mathbb{L}(M)$ such that $\Delta(p) = rp$, for any homogeneous monomial $p \in \mathbb{L}_r(M)$, defines a

derivation of the free Lie algebra. We explicitly have $\Delta([p, q]) = [\Delta(p), q] + [p, \Delta(q)]$ for all $p, q \in \mathbb{L}(M)$. We equip the sum $\mathbb{k}\Delta \oplus \mathbb{L}(M)$ with the Lie bracket such that $[(a\Delta, p), (b\Delta, q)] = (0, a\Delta(p) - b\Delta(q) + [p, q])$, for any $(p, a\Delta), (q, b\Delta) \in \mathbb{k}\Delta \oplus \mathbb{L}(M)$. We consider the associative algebra morphism $ad : \mathbb{U}\mathbb{L}(M) \rightarrow \mathbf{End}(\mathbb{k}\Delta \oplus \mathbb{L}(M))^{op}$ induced by the (right) adjoint action of the free Lie algebra $\mathbb{L}(M)$ on $\mathbb{k}\Delta \oplus \mathbb{L}(M)$, so that $ad(p) = [-, (0, p)]$, for any $p \in \mathbb{L}(M)$.

For a homogeneous Lie monomial $p \in \mathbb{L}_r(M)$, we have

$$ad(p)(\Delta, 0) = [(\Delta, 0), (0, p)] = (0, \Delta(p)) = (0, rp).$$

For a tensor algebra monomial $x_1 \cdot \dots \cdot x_r \in \mathbb{T}(M)$, identified with a product of generating elements $x_1, \dots, x_r \in M$ in the enveloping algebra $\mathbb{T}(M) = \mathbb{U}\mathbb{L}(M)$, we obtain on the other hand $ad(x_1 \cdot \dots \cdot x_r)(\Delta, 0) = ad(x_r) \cdot \dots \cdot ad(x_1)(\Delta, 0) = (0, [\dots [[x_1, x_2], x_3], \dots, x_r])$, and the conclusion of proposition follows. \square

The structure theorems of Hopf algebras, which we explain soon, give a characterization of the object $\mathbb{L}(M)$ within the tensor algebra $\mathbb{T}(M)$, and in the sequel, we actually use this representation when we need to handle free Lie algebra structures.

7.2.9. The classical definition of enveloping algebras. In the module context, the enveloping algebra $\mathbb{U}(\mathfrak{g})$ of a Lie algebra \mathfrak{g} is classically defined as a quotient

$$\mathbb{U}(\mathfrak{g}) = \mathbb{T}(\mathfrak{g}) / \langle x \cdot y - y \cdot x - [x, y] \mid x, y \in \mathfrak{g} \rangle,$$

where we divide the tensor algebra $\mathbb{T}(\mathfrak{g})$ by the ideal generated by the relations $x \cdot y - y \cdot x - [x, y] \equiv 0$, for $x, y \in \mathfrak{g}$. The morphism $\iota : \mathfrak{g} \rightarrow \mathbb{U}(\mathfrak{g})$ associated with the enveloping algebra $\mathbb{U}(\mathfrak{g})$ is defined as the composite of the morphism $\iota : \mathfrak{g} \rightarrow \mathbb{T}(\mathfrak{g})$ with the canonical quotient morphism $q : \mathbb{T}(\mathfrak{g}) \rightarrow \mathbb{U}(\mathfrak{g})$. In general, we use the same notation for the elements of the tensor algebra and their image in the enveloping algebra. Intuitively, the quotient process makes the commutator of Lie algebra elements $x, y \in \mathfrak{g}$ equal to the image of the Lie bracket $[x, y] \in \mathfrak{g}$ in the enveloping algebra $\mathbb{U}(\mathfrak{g})$.

From this quotient definition, we easily retrieve that the enveloping algebra $\mathbb{U}(\mathfrak{g})$ fits in an adjunction relation $\mathbf{Mor}_{\mathcal{A}s_+}(\mathbb{U}(\mathfrak{g}), A) = \mathbf{Mor}_{\mathcal{L}ie}(\mathfrak{g}, A)$, for $A \in \mathcal{A}s_+$, and so that the canonical morphism $\iota : \mathfrak{g} \rightarrow \mathbb{U}(\mathfrak{g})$ represents the adjunction unit. The morphism of unitary associative algebras $\phi_f : \mathbb{U}(\mathfrak{g}) \rightarrow A$ associated to a Lie algebra morphism $f : \mathfrak{g} \rightarrow A$ is given by the same formula as in the tensor algebra case $\phi_f(x_1 \cdot \dots \cdot x_r) = f(x_1) \cdot \dots \cdot f(x_r)$, except that we now assume that the monomial $x_1 \cdot \dots \cdot x_r$ represents an element of the enveloping algebra $\mathbb{U}(\mathfrak{g})$.

We use the adjunction relation of enveloping algebras to establish the following structure result:

PROPOSITION 7.2.10. *The enveloping algebra of a Lie algebra $\mathbb{U}(\mathfrak{g})$ inherits a Hopf algebra structure such that:*

- the augmentation $\epsilon : \mathbb{U}(\mathfrak{g}) \rightarrow \mathbb{1}$ is the morphism of unitary associative algebras induced by the zero morphism $\epsilon(x) = 0$ from the Lie algebra \mathfrak{g} to the unit object $\mathbb{1}$,
- the coproduct $\Delta : \mathbb{U}(\mathfrak{g}) \rightarrow \mathbb{U}(\mathfrak{g}) \otimes \mathbb{U}(\mathfrak{g})$ is the morphism of unitary associative algebras whose restriction to the Lie algebra \mathfrak{g} is given by the formula $\Delta(x) = x \otimes \mathbb{1} + \mathbb{1} \otimes x$,
- the antipode $\sigma : \mathbb{U}(\mathfrak{g}) \rightarrow \mathbb{U}(\mathfrak{g})$ is the anti-morphism of unitary associative algebras whose restriction to the Lie algebra \mathfrak{g} is given by the opposite of the identity map $\sigma(x) = -x$.

EXPLANATIONS. This proposition follows from the same argument line as Proposition 7.2.6 (about the Hopf algebra structures of tensor and symmetric algebras). For our purpose, we only have to check that the formulas of the proposition correspond to the definition of Lie algebra morphisms on \mathfrak{g} since this condition is required for the construction of well-defined structure morphisms on the enveloping algebra.

The condition is obvious for the augmentation. In the case of the coproduct, we readily obtain $[\Delta(x), \Delta(y)] = [x, y] \otimes 1 + 1 \otimes [x, y]$ in the algebra tensor product $\mathbb{U}(\mathfrak{g}) \otimes \mathbb{U}(\mathfrak{g})$, and therefore we have $[\Delta(x), \Delta(y)] = \Delta([x, y])$. In the case of the antipode, we have $\sigma([x, y]) = -[x, y] = yx - xy = \sigma(y)\sigma(x) - \sigma(x)\sigma(y)$, and this result agrees with the commutator of $\sigma(x)$ and $\sigma(y)$ (in this order) in the opposite algebra $\mathbb{U}(\mathfrak{g})^{op}$.

The explicit formulas for the augmentation, the coproduct, and the antipode of monomials are also the same as in the tensor algebra case. \square

The first objective of the Lie theory of Hopf algebras is to identify the image of a Lie algebra \mathfrak{g} in the associated enveloping algebra $\mathbb{U}(\mathfrak{g})$. For this aim, we explain the definition of a primitive element functor on coalgebras. Intuitively, the primitive element functor represents an infinitesimal version of the group-like element functor considered in the previous section.

7.2.11. *Primitive elements in counitary cocommutative coalgebras.* The primitive element functor on the category of coalgebras is defined by:

$$\mathbb{P}(C) = \{x \in C \mid \epsilon(x) = 0, \Delta(x) = x \otimes 1 + 1 \otimes x\}.$$

In the module context, we immediately see that this definition returns a submodule of the coalgebra $\mathbb{P}(C) \subset C$. In a general setting, we define the object $\mathbb{P}(C)$ by an appropriate kernel in the ambient category \mathcal{M} .

To simplify our presentation, we assume from now on that the base category is equipped with kernels (in addition to biproducts and colimits). Nevertheless, in each statement where we explicitly determine primitive elements of Hopf algebras, we proceed by a direct approach, without assuming the existence of a sub-object of primitive elements as a preliminary result. In general, we only need the existence of split kernels for idempotent morphisms. This assumption is actually sufficient for the Poincaré-Birkhoff-Witt Theorem (in our formulation), and for the Milnor-Moore Theorem.

The following observations parallel the assertions of Proposition 7.1.15 (concerning the definition of a group structure on group-like elements):

PROPOSITION 7.2.12. *In a Hopf algebra H , we have $[\mathbb{P}(H), \mathbb{P}(H)] \subset \mathbb{P}(H)$, where $[-, -]$ refers to the commutator $[x, y] = xy - yx$ defined from the underlying product of the Hopf algebra.*

The object $\mathbb{P}(H) \subset H$ consequently inherits a Lie algebra structure with the morphism $[-, -] : \mathbb{P}(H) \otimes \mathbb{P}(H) \rightarrow \mathbb{P}(H)$ induced by the commutator of H as Lie bracket.

PROOF. In the proof of Proposition 7.2.10, we already used an identity of the form $[x \otimes 1 + 1 \otimes x, y \otimes 1 + 1 \otimes y] = [x, y] \otimes 1 + 1 \otimes [x, y]$. If we assume $\Delta(x) = x \otimes 1 + 1 \otimes x$ and $\Delta(y) = y \otimes 1 + 1 \otimes y$, then we deduce from this relation that $\Delta([x, y]) = [\Delta(x), \Delta(y)] = [x, y] \otimes 1 + 1 \otimes [x, y]$. We clearly have $\epsilon(x) = \epsilon(y) = 0 \Rightarrow \epsilon([x, y]) = [\epsilon(x), \epsilon(y)] = 0$ too, and these verifications establish that the object $\mathbb{P}(H)$ is stable under commutators, which is the claim of the proposition. \square

PROPOSITION 7.2.13. *The functor of primitive elements $\mathbb{P} : \mathcal{HopfGrp} \rightarrow \mathcal{Lie}$ is right adjoint to the enveloping algebra functor $\mathbb{U} : \mathcal{Lie} \rightarrow \mathcal{HopfGrp}$ (which we regard as a functor towards the category of Hopf algebras by using the result of Proposition 7.2.10).*

PROOF. Let \mathfrak{g} be a Lie algebra. Let H be a Hopf algebra. We elaborate on the adjunction relation of §7.2.7, between Lie algebra morphisms $f : \mathfrak{g} \rightarrow H$ and unitary associative algebra morphisms $\phi = \phi_f : \mathbb{U}(\mathfrak{g}) \rightarrow H$. We use point-wise formulas to make our argument more explicit, as usual.

We have $f = \phi_f \circ \iota_{\mathfrak{g}}$ (by definition of this adjunction), and as a consequence, we have $f(\mathfrak{g}) \subset \mathbb{P}(H)$ (equivalently, f comes from a Lie algebra morphism towards $\mathbb{P}(H)$), if and only if the associated morphism of unitary associative algebras $\phi : \mathbb{U}(\mathfrak{g}) \rightarrow H$ satisfies $\epsilon\phi(x) = 0 = \epsilon(x)$ and $\Delta\phi(x) = f(x) \otimes 1 + 1 \otimes f(x) = \phi \otimes \phi \cdot \Delta(x)$ for any $x \in \mathfrak{g}$. We deduce from the injectivity of the adjunction correspondence that the verification of these relations on \mathfrak{g} implies that the identities $\epsilon\phi = \epsilon$ and $\Delta\phi = \phi \otimes \phi \cdot \Delta$ holds on the whole $\mathbb{U}(\mathfrak{g})$. We therefore conclude that the adjunction relation of §7.2.7 restricts to an adjunction relation between Lie algebra morphisms $f : \mathfrak{g} \rightarrow \mathbb{P}(H)$ and Hopf algebra morphisms $\phi : \mathbb{U}(\mathfrak{g}) \rightarrow H$ and this result proves the claim of our proposition. \square

The Milnor-Moore Theorem, which we state soon, implies that this adjunction defines an equivalence of categories when we restrict ourselves to a subcategory of Hopf algebras satisfying an appropriate conilpotence condition. Before addressing this general statement, we determine the primitive elements of the symmetric algebra and of the tensor algebra. The result reads as follows:

PROPOSITION 7.2.14.

- (a) *For the symmetric algebra $\mathbb{S}(M)$, which comes equipped with the Hopf algebra structure of Proposition 7.2.6, we have $\mathbb{P}\mathbb{S}(M) = M$.*
- (b) *For the tensor algebra $\mathbb{T}(M)$, which comes equipped with the Hopf algebra structure of Proposition 7.2.6, the morphism $\iota : \mathbb{L}(M) \rightarrow \mathbb{T}(M)$ of §§ 7.2.7-7.2.8 defines an isomorphism between the free Lie algebra $\mathbb{L}(M)$ and the Lie algebra of primitive elements $\mathbb{P}\mathbb{T}(M) \subset \mathbb{T}(M)$.*

This identity $\mathbb{P}\mathbb{T}(M) = \mathbb{L}(M)$ gives our working realization of free Lie algebras.

PROOF. We use point-wise formulas again, in order to make our argument more explicit.

The definition of the coproduct in the symmetric algebra $\mathbb{S}(M)$ immediately implies $M \subset \mathbb{P}\mathbb{S}(M)$. To check the converse inclusion, we consider the morphism $\phi : \mathbb{S}(M) \rightarrow \mathbb{S}(M)$ induced by the projection onto the summand $\mathbb{S}_1(M) = M \subset \mathbb{S}(M)$. For a homogeneous element $u \in \mathbb{S}_r(M)$ of weight $r > 0$, we have $u = (1/r) \cdot \sum_{(u)} u_{(1)} \cdot \phi(u_{(2)})$. (We can easily check this identity on monomials $u = x_1 \cdot \dots \cdot x_r$, by using the explicit formula of the coproduct in the proof of Proposition 7.2.6.) This equation implies the following belonging relation $u \in \mathbb{P}\mathbb{S}(M) \Rightarrow u = u \cdot \phi(1) + 1 \cdot \phi(u) = \phi(u) \Rightarrow u \in M$, which completes the verification of the identity $\mathbb{P}\mathbb{S}(M) = M$.

In the case of the tensor algebra, we again immediately have $M \subset \mathbb{P}\mathbb{T}(M)$, and this inclusion implies $\mathbb{L}(M) \subset \mathbb{P}\mathbb{T}(M)$ since primitive elements are preserved by commutators (see Proposition 7.2.12). To check the converse inclusion, we consider

the morphism $\psi : \mathbb{T}(M) \rightarrow \mathbb{T}(M)$ (closely related to the morphism of Proposition 7.2.8) such that $\psi(x_1 \cdots x_r) = [\cdots [[x_1, x_2], x_3], \dots, x_r]$. For a homogeneous element $u \in \mathbb{T}_r(M)$ of weight $r > 0$, we have again $u = (1/r) \cdot \sum_{(u)} u_{(1)} \cdot \psi(u_{(2)})$. (We refer to the article [178], from which we borrow this argument, for a detailed proof of this identity.) This equation readily implies, as in the symmetric algebra case, that we have $u \Rightarrow \mathbb{P}\mathbb{T}(M) \Rightarrow u \in \mathbb{L}(M)$ and the proof of this belonging relation completes the verification of our identity $\mathbb{P}\mathbb{T}(M) = \mathbb{L}(M)$. \square

This proposition gives a preliminary step of our proof of the Poincaré-Birkhoff-Witt Theorem. But we have to explain the concept of a locally conilpotent Hopf algebra before going further into our study.

7.2.15. *Locally conilpotent Hopf algebras.* We give a definition of the subcategory of locally conilpotent Hopf algebras which makes sense in any \mathbb{Q} -additive base category. We proceed as follows.

In any Hopf algebra H the relation $\epsilon\eta = id$, between the unit $\eta : \mathbb{1} \rightarrow H$ and the counit $\epsilon : H \rightarrow \mathbb{1}$, implies that we have a decomposition $H = \mathbb{1} \oplus \mathbb{L}(H)$, where we set $\mathbb{L}(H) = \ker(\epsilon : H \rightarrow \mathbb{1})$. We call this subobject $\mathbb{L}(H)$ the augmentation ideal of the Hopf algebra H . We consider the morphism $\pi = id - \epsilon\eta$, which defines the projector associated to this summand $\mathbb{L}(H)$ in the Hopf algebra H .

Let $\Delta^{(n)} : H \rightarrow H^{\otimes n}$ denote the n -fold coproduct associated to our Hopf algebra (see §7.1.1). Let $\pi^{(n)} : H^{\otimes n} \rightarrow H^{\otimes n}$ denote the n -fold tensor power of our projector π . The composite $\pi^{(n)}\Delta^{(n)}$ represents the components of the n -fold coproduct $\Delta^{(n)}$ on the summand $\mathbb{L}(H)^{\otimes n}$ of the tensor product $H^{\otimes n}$, and where all occurrences of unit factors have been removed.

We generally say that H is locally conilpotent when H admits a colimit decomposition $K^0 \rightarrow \cdots \rightarrow K^m \rightarrow \cdots \rightarrow \text{colim}_m K^m = H$ such that:

- (a) we have $\pi^{(n)}\Delta^{(n)} \upharpoonright_{K^m} = 0$ as soon as $n > m$;
- (b) and the coproduct $H \rightarrow H \otimes H$ admits a factorization

$$\begin{array}{ccc} H & \xrightarrow{\Delta} & H \otimes H \\ \uparrow & & \uparrow \\ K^m & \xrightarrow{\exists} & \text{colim}_{p+q \leq m} K^p \otimes K^q \end{array} \quad ,$$

for each $m \in \mathbb{N}$.

We use the notation $\mathcal{H}opf\mathcal{G}rp_c$ for the full subcategory of the category of Hopf algebras $\mathcal{H}opf\mathcal{G}rp$ formed by the locally conilpotent Hopf algebras.

We can retrieve the definition of [145, §B.3] (where our locally conilpotent Hopf algebras are called connected Hopf algebras) by taking $K^m = \ker(\pi^{(m+1)}\Delta^{(m+1)})$. We easily check (by using the coassociativity of the coproduct) that these kernels form a nested sequence $\ker(\pi^{(1)}\Delta^{(1)}) \subset \cdots \subset \ker(\pi^{(m+1)}\Delta^{(m+1)}) \subset \cdots \subset H$. We automatically have the vanishing condition (a). When we work in a category of modules over a field (so that the tensor product preserves kernels), we easily check (by using the coassociativity of the coproduct again) that the coproduct condition (b) is automatically fulfilled too. In this situation, the local conilpotence condition accordingly reduces to $\text{colim}_m \ker(\pi^{(m+1)}\Delta^{(m+1)}) = H$.

The tensor algebra (and the symmetric algebra similarly) is an instance of a locally conilpotent Hopf algebra: we take $K^m = \bigoplus_{r \leq m} \mathbb{T}_r(M)$, and our requirements follow from the expression of the coproduct in Proposition 7.2.6. This object

$K^m = \bigoplus_{r \leq m} \mathbb{T}_r(M)$ actually realizes the kernel of the morphism $\pi^{(m+1)} \Delta^{(m+1)}$ on the tensor algebra. The enveloping algebra $\mathbb{U}(\mathfrak{g})$ of a Lie algebra is locally conilpotent too. In the context of modules over a field, we take $K^m = \text{im}(\bigoplus_{r \leq m} \mathbb{T}_r(\mathfrak{g}) \rightarrow \mathbb{T}(\mathfrak{g}) \rightarrow \mathbb{U}(\mathfrak{g}))$ and our requirements follow from the observation that the coproduct in $\mathbb{U}(\mathfrak{g})$ is identified with a quotient of the coproduct in the tensor algebra $\mathbb{T}(\mathfrak{g})$. In the general context, we can arrange this construction by extending the colimit decomposition $\mathbb{T}(\mathfrak{g}) = \text{colim}_m \{\bigoplus_{r \leq m} \mathbb{T}_r(\mathfrak{g})\}$ to the coequalizer of §7.2.7 which serves to define the enveloping algebra.

We can now state the first main structure theorem of the theory of Hopf algebras:

THEOREM 7.2.16 (Structure Theorem). *Let H be a Hopf algebra. The morphism $e : \mathbb{S}\mathbb{P}(H) \rightarrow H$ defined by the symmetrized sum*

$$e(x_1 \cdots x_r) = (1/r!) \cdot \sum_{\sigma \in \Sigma_r} x_{\sigma(1)} \cdots x_{\sigma(r)}$$

on the symmetric algebra monomials $x_1 \cdots x_r \in \mathbb{S}(\mathbb{P}(H))$ is an isomorphism of counitary cocommutative coalgebras as soon as H is locally conilpotent (see §7.2.15).

PROOF. The proof of this theorem forms the technical heart of this section. We adapt ideas of [142] (see also [38, 141]) and divide our argument line in several steps.

Preliminaries: Convolution algebras. Let $\mathbf{End}(H)$ be the module formed by the endomorphisms $f : H \rightarrow H$ of the Hopf algebra H . The composition of endomorphisms gives a product \circ providing the module $\mathbf{End}(H)$ with a natural unitary associative algebra structure. To produce the isomorphism considered in the theorem, we use that $\mathbf{End}(H)$ is equipped with an additional unitary associative product, called to the convolution product, and defined by the formula:

$$(f * g)(u) = \sum_{(u)} f(u_{(1)}) \cdot g(u_{(2)})$$

for $f, g \in \mathbf{End}(H)$, and $u \in H$. The morphism $\eta\epsilon$, defined by the composite of the unit and of the counit of the Hopf algebra, is a unit with respect to the convolution product since we have $(\eta\epsilon * f)(u) = \sum_{(u)} \epsilon(u_{(1)}) \cdot f(u_{(2)}) = f(\sum_{(u)} \epsilon(u_{(1)}) \cdot u_{(2)}) = f(u)$ and similarly $(f * \eta\epsilon)(u) = f(u)$.

Let us observe that the definition of this convolution structure makes sense in the more general case of a hom-object $\mathbf{Hom}(C, A)$ such that C is a counitary cocommutative (or coassociative) coalgebra and A is a unitary associative algebra. In the course of our verifications, we use convolution structures attached to the hom-objects $\mathbf{Hom}(H, H \otimes H)$ and $\mathbf{Hom}(H \otimes H, H \otimes H)$. In these cases, we use the natural counitary cocommutative coalgebra (respectively, unitary associative algebra) structures attached to a tensor product of Hopf algebras to define the convolution product.

For our purpose, we still consider the morphism $\pi : H \rightarrow H$ such that $\pi = id - \eta\epsilon \Leftrightarrow id = \eta\epsilon + \pi$. Recall that this morphism defines the projector associated to the summand $\mathbb{1}(H) = \ker(\epsilon : H \rightarrow \mathbb{1})$ of our Hopf algebra H (see §7.2.15).

Step 1: A subalgebra of the convolution algebra. In a preliminary step, we consider the elements such that $\pi^n = \pi^{*n}$, for $n \in \mathbb{N}$. To make our subsequent argument lines work, we need to give a sense to formal sums $\sum_{n=0}^{\infty} \lambda_n \pi^n$, $\lambda_n \in \mathbb{Q}$, in the endomorphism algebra. For this purpose, we use the colimit decomposition

$H = \operatorname{colim}_m K^m$ arising from the local conilpotence condition. Our elements π^n are identified with composites $\pi^n = \nabla^{(n)}\pi^{(n)}\Delta^{(n)}$, where $\Delta^{(n)} : H \rightarrow H^{\otimes n}$ denotes the n -fold coproduct of our Hopf algebra (as in §7.2.15), the morphism $\pi^{(n)} : H^{\otimes n} \rightarrow H^{\otimes n}$ is the n -fold tensor power of our projector π , and $\nabla^{(n)} : H^{\otimes n} \rightarrow H$ denotes the n -fold product. By definition of the local conilpotence condition (in §7.2.15), we have $\pi^{(n)}\Delta^{(n)}(K^m) = 0 \Rightarrow \pi^n(K^m) = 0$ for all $n > m$, and we identify our formal sums with the definition of elements in the limit of hom-objects $\operatorname{End}(H) = \lim_m \operatorname{Hom}(K^m, H)$.

Let $\mathbf{S} = \{\sum_{n=0}^{\infty} \lambda_n \pi^n \mid \lambda_n \in \mathbb{Q} (\forall n)\}$ be the submodule of the endomorphism algebra formed by the morphisms f which admits an expansion of this form $f = \sum_{n=0}^{\infty} \lambda_n \pi^n$. We have $\pi^m * \pi^n = \pi^{m+n}$ and we can readily check, by using the coproduct condition §7.2.15(b) in our definition of the local conilpotence, that the usual extension of this formula to power series $f = \sum_{n=0}^{\infty} \lambda_n \pi^n$ corresponds to the convolution product on morphisms $f \in \operatorname{End}(H)$. We obtain, therefore, that our module \mathbf{S} forms a subalgebra of the endomorphism algebra $\operatorname{End}(H)$ with respect to the convolution structure.

In contrast, we face difficulties when we aim to analyze the composition product of our power series. We will be able to sort out this point by using a new collection of elements $e^s \in \operatorname{End}(H)$ which we define by the formulas:

$$e^1 = \log_*(id) = \log_*(\eta\epsilon + \pi) = \sum_{n=1}^{\infty} (-1)^{n-1} \cdot \frac{\pi^n}{n},$$

$$e^s = \frac{(e^1)^{*s}}{s!}, \quad \text{for } s \in \mathbb{N}.$$

We see that each e^s has an expansion of the form $e^s = \sum_{n \geq s} \lambda_n \pi^n$. We can therefore form infinite sums $\sum_s c_s e^s$. We moreover have the relation

$$\mathbf{S} = \{\sum_{n=0}^{\infty} \lambda_n \pi^n \mid \lambda_n \in \mathbb{Q} (\forall n)\} = \{\sum_{s=0}^{\infty} c_s e^s \mid c_s \in \mathbb{Q} (\forall s)\}$$

inside the endomorphism algebra $\operatorname{End}(H)$.

Step 2: the coproduct relations. In an intermediate step, we determine a distribution relation between the action of the elements e^s and the coproduct of the Hopf algebra H . For this purpose, we use the convolution structure associated with the hom-objects $\operatorname{Hom}(H, H \otimes H)$ and $\operatorname{Hom}(H \otimes H, H \otimes H)$. We have an obvious extension of the formal sum representation of Step 1 to $\operatorname{Hom}(H, H \otimes H)$ since we also have a limit decomposition $\operatorname{Hom}(H, H \otimes H) = \lim_n \operatorname{Hom}(K^n, H \otimes H)$ in this case. We have a similar observation for the hom-object $\operatorname{Hom}(H \otimes H, H \otimes H)$, for which we use $\operatorname{Hom}(H \otimes H, H \otimes H) = \lim_{pq} \operatorname{Hom}(K^p \otimes K^q, H \otimes H)$.

We can easily check that the distribution relation between the coproduct and the product in H implies the distribution relation $\Delta \circ (f * g) = (\Delta \circ f) * (\Delta \circ g)$ when we form the composite of morphisms $f, g \in \operatorname{Hom}(H, H)$ with the coproduct $\Delta \in \operatorname{Hom}(H, H \otimes H)$. We accordingly obtain that the mapping $\Delta \circ - : f \mapsto \Delta \circ f$ defines a morphism of convolution algebras $\Delta \circ - : \operatorname{Hom}(H, H) \rightarrow \operatorname{Hom}(H, H \otimes H)$. We have a similar result for the mapping $- \circ \Delta : \operatorname{Hom}(H \otimes H, H \otimes H) \rightarrow \operatorname{Hom}(H, H \otimes H)$. We observe the commutativity of the coproduct at this point (or, equivalently, the observation that the coproduct defines a morphism of coalgebras).

We examine the composite of the element $e^1 = \log_*(id)$ with the coproduct. We have $\Delta \circ id = (id \otimes id) \circ \Delta$, and we deduce from the usual logarithm addition

formula that:

$$\begin{aligned}\Delta \circ \log_*(id) &= \log_*(id \otimes id) \circ \Delta \\ &= \log_*((id \otimes \eta\epsilon) * (\eta\epsilon \otimes id)) \circ \Delta \\ &= (\log_*(id) \otimes \eta\epsilon + \eta\epsilon \otimes \log_*(id)) \circ \Delta.\end{aligned}$$

Again, we use at this point the coproduct condition in the definition of local conilpotence §7.2.15(b) in order to give a sense to the above identities in our limit of hom-objects.

We have $e^0 = (e^1)^{*0} = \eta\epsilon$ (the convolution unit), and accordingly, we can rewrite the above result as $\Delta(e^1) = (e^1 \otimes e^0 + e^0 \otimes e^1) \circ \Delta$. When we deal with a general element $e^r = (e^1)^{*r}/r!$, we have $\Delta \circ e^r = (\Delta \circ e^1)^{*r}/r!$, and a simple computation gives the formula:

$$(*) \quad \Delta \circ e^r = \sum_{s+t=r} (e^s \otimes e^t) \circ \Delta,$$

for all $r \in \mathbb{N}$.

Step 3: the Eulerian idempotents. We now prove that the endomorphisms e^s , $s \in \mathbb{N}$, form a complete collection of orthogonal idempotents in the endomorphism algebra $\mathbf{End}(H)$. For this purpose, we consider a third collection of elements, which we define by the simple formula $\psi^n = id^{*n}$, where $id : H \rightarrow H$ is the identity morphism. For each $n \in \mathbb{N}$, we have:

$$\psi^n = \exp_*(n \log_*(id)) = \sum_{s=0}^{\infty} n^s e^s,$$

where we define the exponential $\exp_*(x)$ by the usual power series expansion in the convolution algebra.

Recall that we use the notation $\Delta^{(n)}$ for the n -fold coproduct of the Hopf algebra H and the notation $\nabla^{(n)}$ for the n -fold product. We have already observed that we have $\pi^n = \nabla^{(n)}\pi^{(n)}\Delta^{(n)}$ for the elements introduced in Step 1, where we set $\pi^{(n)} = \pi^{\otimes n}$. We can also immediately deduce, from the definition of the convolution product, that our new elements $\psi^n = id^{*n}$ are identified with the composites $\psi^n = \nabla^{(n)}\Delta^{(n)}$.

We obtain, from the distribution relation (*), that we have:

$$(\nabla^{(n)}\pi^{(n)}\Delta^{(n)}) \circ e^r = \nabla^{(n)} \left[\sum_{r_1+\dots+r_n=r} (\pi \circ e^{r_1}) \otimes \dots \otimes (\pi \circ e^{r_n}) \right] \circ \Delta^{(n)}$$

This formula implies the relation

$$\pi^n \circ e^r = 0$$

for $n > r$ since we have $\pi e^0 = \pi\eta\epsilon = 0$. We similarly obtain that:

$$\begin{aligned}\psi^n \circ e^r &= (\nabla^{(n)}\Delta^{(n)}) \circ e^r \\ &= \sum_{r_1+\dots+r_n=r} (e^{r_1} * \dots * e^{r_n}) = \sum_{r_1+\dots+r_n=r} \frac{r!}{r_1! \dots r_n!} \cdot e^r \\ &= n^r e^r,\end{aligned}$$

for all $n \in \mathbb{N}$, $r \in \mathbb{N}$.

We consider the variants $\mathbf{S}_r = \{\sum_{s=r}^{\infty} c_s e^s \mid c_s \in \mathbb{Q}(\forall s)\} = \{\sum_{n=r}^{\infty} \lambda_n \pi^n \mid \lambda_n \in \mathbb{Q}(\forall n)\}$, of the module $\mathbf{S} = \mathbf{S}_0$ introduced in Step 1. We form the quotient object $\mathbf{S}/\mathbf{S}_{r+1}$ and we set $\bar{p} \in \mathbf{S}/\mathbf{S}_{r+1}$ for the image of an element $p \in \mathbf{S}$ in this quotient. From the definition of the element ψ^n , we deduce the relation:

$$\bar{\psi}^n = \sum_{s=0}^r n^s \bar{e}^s \Rightarrow \bar{e}^s = \sum_{n=0}^r \theta_{ns} \bar{\psi}^n,$$

where $(\theta_{ns})_{n,s}$ denotes the inverse of the Vandermonde matrix $(n^s)_{n,s}$.

We deduce from the vanishing of the product $\pi^n \circ e^r$ for $n > r$ that we have the relation $\mathbf{S}_{r+1} \circ e^r = 0$. The mapping $\rho : f \mapsto f \circ e^r$ accordingly induces a linear map $\rho : \mathbf{S}/\mathbf{S}_{r+1} \rightarrow \mathbf{End}(H)$. We deduce from our computation of the product $\psi^n \circ e^r$ that we have the formula $\rho(\bar{\psi}^n) = n^r e^r$, for all $n \in \mathbb{N}$. By using the Vandermonde matrix again, we obtain $\rho(\bar{e}^s) = \sum_{n=0}^r \theta_{ns} \rho(\bar{\psi}^n) = \sum_{n=0}^r \theta_{ns} n^r e^r = \delta_{rs}^r e^r$, where δ_{rs} is the Kronecker delta (compare this argument with [118]). This computation finishes the proof that our elements e^r , $r \in \mathbb{N}$, satisfy the relations

$$e^s \circ e^t = \begin{cases} e^s, & \text{if } s = t, \\ 0, & \text{otherwise,} \end{cases}$$

and hence, form a complete set of orthogonal idempotents in the endomorphism algebra.

From now on, we use the name of Eulerian idempotents (following the convention of the article [142]) to refer to these elements e^s , $s \in \mathbb{N}$. The original Eulerian idempotents, as defined in [146], are collections of idempotent elements e_n^s defined in the group algebra of the symmetric groups $\mathbb{Q}[\Sigma_n]$, and which correspond to our idempotent morphisms $e^s \in \mathbf{End}(H)$ in the case of the tensor algebra $H = \mathbb{T}(M)$ (see [118, 142] and [147, §9]).

Step 4: the Eulerian splitting. We consider the splitting

$$H = \bigoplus_{r=0}^{\infty} e^r(H)$$

deduced from the action of the Eulerian idempotents on the Hopf algebra. Recall that we have $e^0 = \eta\epsilon$, the unit of the convolution product. We readily see that $e^1(H) \subset \mathbb{P}(H)$, because we have $e^0 e^1(u) = 0 \Rightarrow \epsilon(e^1(u)) = 0$, and for $r = 1$, the distribution relation (*) implies:

$$\begin{aligned} \Delta(e^1(u)) &= \sum_{(u)} [e^1(u_{(1)}) \otimes e^0(u_{(2)}) + e^0(u_{(1)}) \otimes e^1(u_{(2)})] \\ &= \sum_{(u)} [\epsilon(u_{(2)}) \cdot e^1(u_{(1)}) \otimes 1 + 1 \otimes \epsilon(u_{(1)}) \cdot e^1(u_{(2)})] \\ &= e^1(u) \otimes 1 + 1 \otimes e^1(u). \end{aligned}$$

We aim to prove that this inclusion $e^1(H) \subset \mathbb{P}(H)$ is an equality and that we have in addition $e^r(H) = \mathbb{S}_r(e^1(H))$.

Recall that we set $\mathbb{1}(H) = \ker(\epsilon : H \rightarrow \mathbb{1})$, and the morphism $\pi : H \rightarrow H$, such that $\pi = id - \eta\epsilon = id - e^0$, is identified with the projector associated to this summand of our Hopf algebra. Recall besides that we use the notation $\nabla^{(r)} : H^{\otimes r} \rightarrow H$ for the r -fold product, and the notation $\Delta^{(r)} : H \rightarrow H^{\otimes r}$ for the r -fold coproduct. We also consider the morphism $\pi^{(r)} : H^{\otimes r} \rightarrow H^{\otimes r}$ defined by the tensor power of our projector $\pi : H \rightarrow H$.



We readily check, by applying the distribution formula (*), and the identities $\pi e^0 = 0$, $\pi e^s = e^s$ for $s > 0$, that we have:

$$(**) \quad \pi^{(r)} \Delta^{(r)}(e^r(u)) = \sum_{(u)} e^1(u_{(1)}) \otimes \cdots \otimes e^1(u_{(r)}),$$

for all $u \in H$. We use the symmetrization morphism $\mathbb{S}_r(e^1(H)) \hookrightarrow e^1(H)^{\otimes r} \hookrightarrow H^{\otimes r}$ (defined by the same expression as in the statement of the theorem) to deduce, from the above formula, the existence of a morphism $S_r : e^r(H) \rightarrow \mathbb{S}_r(e^1(H))$ fitting in a commutative diagram

$$\begin{array}{ccc} e^r(H) & \xrightarrow{\quad S_r \quad} & \mathbb{S}(e^1(H)) \\ & \searrow \quad \swarrow & \\ & \pi^{(r)} \Delta^{(r)} & H^{\otimes r} \end{array}$$

We form the composite

$$\mathbb{S}_r(e^1(H)) \hookrightarrow H^{\otimes r} \xrightarrow{(1/r!) \cdot \nabla^{(r)}} H \xrightarrow{e^r} e^r(H)$$

to get a morphism going in the converse direction $\Pi_r : \mathbb{S}_r(e^1(H)) \rightarrow e^r(H)$, for every $r \in \mathbb{N}$.

We use our formula (**) to get the relations

$$\begin{aligned} (1/r!) \cdot \nabla^{(r)} \pi^{(r)} \Delta^{(r)}(e^r(u)) &= (1/r!) \cdot \sum_{(u)} e^1(u_{(1)}) \cdots e^1(u_{(r)}) \\ &= \underbrace{(1/r!) \cdot (e^1 * \cdots * e^1)(u)}_{=e^r(u)} \end{aligned}$$

from which we readily conclude that $\Pi_r S_r(e^r(u)) = e^r(u)$, for every $u \in H$. We now consider the image of a symmetric algebra monomial $\varpi = e^1(u_1) \cdots e^1(u_r) \in \mathbb{S}_r(e^1(H))$ under our morphism Π_r . We readily identify this image $\Pi_r(\varpi)$ with the component $e^r(u) \in e^r(H)$ of the product $u = e^1(u_1) \cdots e^1(u_r)$ in H . We have $\Delta^{(s)}(u) = \Delta^{(s)}(e^1(u_1)) \cdots \Delta^{(s)}(e^1(u_r))$ by distribution between the product and the coproduct in our Hopf algebra. This formula, together with the observation that $e^1(H)$ consists of primitive elements, readily implies that we have $\pi^{(r)} \Delta^{(r)}(u) = \sum_{\sigma \in \Sigma_r} e^1(u_{\sigma(1)}) \otimes \cdots \otimes e^1(u_{\sigma(r)})$, and $\pi^{(s)} \Delta^{(s)}(u) = 0$ whenever $s > r$. We use Equation (**) again to conclude that we retrieve the symmetrization of the monomial $e^1(u_1) \cdots e^1(u_r) \in \mathbb{S}_r(e^1(H))$ when we insert the idempotent e^r in the expression $\pi^{(r)} \Delta^{(r)}(u)$. We therefore have $S_r \Pi_r = id$ in addition to the already established identity $\Pi_r S_r = id$.

We moreover see, by the using the case $s > r$ of our computation, that we have $S_s(e^s(u)) = 0$, when the weight s exceeds the order r of our monomial $u = e^1(u_1) \cdots e^1(u_r)$.

We take the sum of our morphisms Π_r to get an isomorphism $\Pi : \mathbb{S}(e^1(H)) \xrightarrow{\sim} H$. We see that the symmetrization map $e : \mathbb{S}(e^1(H)) \rightarrow H$ (defined as in the statement of the theorem) differs from this iso by the insertion of the idempotents e^r . We use our computation of the image of monomials $u = e^1(u_1) \cdots e^1(u_r)$ under the morphisms $S_s(e^s(-))$ to obtain that the symmetrization map satisfies $e(\mathbb{S}_r(e^1(H))) \subset \bigoplus_{s \leq r} e^s(H)$, and agrees with our isomorphism $\Pi_r : \mathbb{S}_r(e^1(H)) \rightarrow$

$e^r(H)$ on $e^r(H)$. We conclude that this map $e : \mathbb{S}(e^1(H)) \rightarrow H$ is an isomorphism too.

Conclusions. To complete this proof, we can just check, by using the inclusion $e^1(H) \subset \mathbb{P}(H)$ and a straightforward coproduct computation, that e defines a isomorphism in the category of counitary cocommutative coalgebras. Then we use Proposition 7.2.14(a) to obtain the relation $e^1(H) = \mathbb{P} \mathbb{S}(e^1(H)) = \mathbb{P}(H)$ in addition to the definition of this isomorphism $e : \mathbb{S}(e^1(H)) \xrightarrow{\cong} H$. \square

Proposition 7.2.14(b) and Theorem 7.2.16 give the free Lie algebra case of the Poincaré-Birkhoff-Witt Theorem:

THEOREM 7.2.17 (Poincaré-Birkhoff-Witt Theorem). *The morphism $e : \mathbb{S}(\mathfrak{g}) \rightarrow \mathbb{U}(\mathfrak{g})$ defined by the symmetrized sum*

$$e(x_1 \cdot \dots \cdot x_r) = (1/r!) \cdot \sum_{\sigma \in \Sigma_r} x_{\sigma(1)} \cdot \dots \cdot x_{\sigma(r)}$$

on the symmetric algebra monomials $x_1 \cdot \dots \cdot x_r \in \mathbb{S}(\mathfrak{g})$ yields an isomorphism of counitary cocommutative coalgebras from the symmetric algebra $\mathbb{S}(\mathfrak{g})$ to the enveloping algebra $\mathbb{U}(\mathfrak{g})$, for all Lie algebras in our base category $\mathfrak{g} \in \mathcal{L}ie$.

We refer to [1, §3.3] for an another approach of the Poincaré-Birkhoff-Witt Theorem, and to [80] for a historical overview of the subject.

The equivalence between the claim of Theorem 7.2.17 and the combined results of Proposition 7.2.14(b) and Theorem 7.2.16 in the case of a free Lie algebra $\mathfrak{g} = \mathbb{L}(M)$ follows from the identity $\mathbb{U} \mathbb{L}(M) = \mathbb{T}(M)$ (see §7.2.7). The assertion that our morphism $e : \mathbb{S}(\mathfrak{g}) \rightarrow \mathbb{U}(\mathfrak{g})$ is a morphism of counitary cocommutative coalgebras in the theorem follows from a straightforward verification (similar to the verification of the parallel claim of Theorem 7.2.16), and we do not come back to this claim.

The Poincaré-Birkhoff-Witt Theorem (in the formulation of Theorem 7.2.17) is established in [145, Theorem B.2.3] in the module context, and in other usual examples of base categories, like graded modules (in the sense of §4.4), and differential graded modules (which we use later on). Our proof of the free Lie algebra case, provided by Proposition 7.2.14(b) and Theorem 7.2.16 proceeds from a different approach as the proof given in this reference and works as soon as we have kernels for idempotent morphisms. Nevertheless, after establishing the preliminary case of free Lie algebra, we can obtain the proof of general case of Theorem 7.2.17 by the same argument line as in [145, §B.2] (without loss of generality), and this is this argument which we now recall.

PROOF. Explicitly, to establish the general case of our theorem, we use that any Lie algebra \mathfrak{g} fits in a reflexive coequalizer of free Lie algebras

$$\begin{array}{c} \mathbb{L}(M_1) \begin{array}{c} \xrightarrow{d^0} \\ \xrightarrow{d^1} \end{array} \mathbb{L}(M_0) \dashrightarrow \mathfrak{g} \\ \curvearrowright^{s^0} \end{array}$$

of which construction can be deduced from the free Lie algebra adjunction (see [122, §VI.7] for details). The symmetric algebra functor preserves reflexive coequalizers (by the general statements of §1.4) as well as the enveloping algebra functor (by adjunction and because reflexives coequalizers of algebras are created in the underlying category). Thus, our natural transformation fits in a diagram of coequalizers

of the form:

$$\begin{array}{ccccc}
 & \curvearrowright & & & \\
 \mathbb{S}\mathbb{L}(M_1) & \rightrightarrows & \mathbb{S}\mathbb{L}(M_0) & \dashrightarrow & \mathbb{S}(\mathfrak{g}) , \\
 \downarrow \simeq & & \downarrow \simeq & & \downarrow e \\
 \mathbb{T}(M_1) & \rightrightarrows & \mathbb{T}(M_0) & \dashrightarrow & \mathbb{U}(\mathfrak{g})
 \end{array}$$

where we use the identity $\mathbb{U}\mathbb{L}(M) = \mathbb{T}(M)$ of §7.2.7, and the combined results of Proposition 7.2.14(b) and Theorem 7.2.16 to get that this diagram involves isomorphisms between the terms of our coequalizers. The existence of these isomorphisms implies that we get an iso at the level of the coequalizers themselves, and this assertion finishes the proof of our theorem. \square

Theorem 7.2.17 admits the following immediate consequence, which extends the results of Proposition 7.2.14(b) to arbitrary Lie algebras:

THEOREM 7.2.18. *The canonical morphism $\iota : \mathfrak{g} \rightarrow \mathbb{U}(\mathfrak{g})$, associated with an enveloping algebra $\mathbb{U}(\mathfrak{g})$, admits a natural retraction $\rho : \mathbb{U}(\mathfrak{g}) \rightarrow \mathfrak{g}$ and induces an isomorphism between the Lie algebra \mathfrak{g} and the Lie algebra of primitive elements $\mathbb{P}\mathbb{U}(\mathfrak{g}) \subset \mathbb{U}(\mathfrak{g})$.* \square

This result gives one part of the Milnor-Moore Theorem:

THEOREM 7.2.19 (Milnor-Moore Theorem). *The enveloping algebra and primitive element functors $\mathbb{U} : \mathcal{L}ie \rightleftarrows \mathcal{H}opfGrp : \mathbb{P}$ induce adjoint equivalences of categories between the category of Lie algebras $\mathcal{L}ie$ and the subcategory of locally conilpotent Hopf algebras $\mathcal{H}opfGrp_c$.*

The original Milnor-Moore Theorem [138] deals with Hopf algebras in (weight) graded modules satisfying a stronger conilpotence condition, which we study in the next section (see §7.3.16). The reference [145, Theorem B.4.5] provides a generalization of Milnor-Moore' statement to the setting of locally conilpotent (connected) Hopf algebras in \mathbb{Q} -modules (respectively, graded modules, differential graded modules). We give a direct proof of the general case of our theorem, by relying on the results of Theorem 7.2.16 (the Structure Theorem), Theorem 7.2.17 (the Poincaré-Birkhoff-Witt Theorem). and Theorem 7.2.18, which we already obtained as a corollary of these preliminary statements.

7/3/13

PROOF. The claim of Theorem 7.2.18 actually gives one inversion relation of our category equivalence $\mathfrak{g} \xrightarrow{\simeq} \mathbb{P}\mathbb{U}(\mathfrak{g})$, and we use the statements of Theorem 7.2.16 and Theorem 7.2.17. to get the converse relation $\mathbb{U}\mathbb{P}(H) \xrightarrow{\simeq} H$. For this purpose, we simply observe that our morphism $\mathbb{U}\mathbb{P}(H) \rightarrow H$ fits in a commutative triangle

$$\begin{array}{ccc}
 & \mathbb{U}\mathbb{P}(H) , & \\
 & \nearrow \simeq & \downarrow \\
 \mathbb{S}\mathbb{P}(H) & & H \\
 & \searrow \simeq & \\
 & &
 \end{array}$$

where the diagonal morphisms are the isos of Theorem 7.2.16 and Theorem 7.2.17. \square

To complete the survey of this section, and as a preparation for applications to operads, we examine the definition of a symmetric monoidal structure on Lie algebras.

7.2.20. *Direct sums of Lie algebras.* The category of Lie algebras inherit limits and colimits, like any category of algebras over an operad, so that the limits, as well as the filtered colimits and the reflexive coequalizers, are created in the ambient symmetric monoidal category. In our setting, we also have an identity between the direct sum $\mathfrak{g} \oplus \mathfrak{h}$ and the product of \mathfrak{g} and \mathfrak{h} in the category of Lie algebras since we assume that the ambient category is additive. We precisely take this direct sum operation $\oplus : \mathcal{L}ie \times \mathcal{L}ie \rightarrow \mathcal{L}ie$ to provide the category of Lie algebras $\mathcal{L}ie$ with a symmetric monoidal structure. The zero object 0 , which also represents the initial object in the category of Lie algebras, defines the monoidal unit. The axioms are trivially satisfied for this symmetric monoidal structure, but we must note that the colimit preservation requirement of §0.9 is not fulfilled.

The Lie bracket of the Lie algebra $\mathfrak{g} \oplus \mathfrak{h}$ is defined by $[(x_1, y_1), (x_2, y_2)] = ([x_1, x_2], [y_1, y_2])$, for any $x_1, x_2 \in \mathfrak{g}$, $y_1, y_2 \in \mathfrak{h}$.

The canonical embeddings $i : \mathfrak{g} \rightarrow \mathfrak{g} \oplus \mathfrak{h}$ and $j : \mathfrak{h} \rightarrow \mathfrak{g} \oplus \mathfrak{h}$ define morphisms of Lie algebras. We moreover have $[i(\mathfrak{g}), j(\mathfrak{h})] = 0$ in $\mathfrak{g} \oplus \mathfrak{h}$. We readily see that the Lie algebra $\mathfrak{g} \oplus \mathfrak{h}$ is universal with this property so that giving a morphism from $\mathfrak{g} \oplus \mathfrak{h}$ towards a Lie algebra \mathfrak{m} amounts to giving a pair of Lie algebra morphism $(f : \mathfrak{g} \rightarrow \mathfrak{m}, g : \mathfrak{h} \rightarrow \mathfrak{m})$ such that $[f(\mathfrak{g}), g(\mathfrak{h})] = 0$ in \mathfrak{m} . This result holds in the general setting of \mathbb{Q} -additive symmetric monoidal categories.

The Lie algebra embeddings $\mathfrak{g} \xrightarrow{i} \mathfrak{g} \oplus \mathfrak{h} \xleftarrow{j} \mathfrak{h}$ induce morphisms $\mathcal{U}(\mathfrak{g}) \xrightarrow{i_*} \mathcal{U}(\mathfrak{g} \oplus \mathfrak{h}) \xleftarrow{j_*} \mathcal{U}(\mathfrak{h})$ at the enveloping algebra level, and we can use the product of the enveloping algebra in order to get a morphism $\mu(i_*, j_*) : \mathcal{U}(\mathfrak{g}) \otimes \mathcal{U}(\mathfrak{h}) \rightarrow \mathcal{U}(\mathfrak{g} \oplus \mathfrak{h})$ so that $\mu(i_*, j_*)(u \otimes v) = i_*(u) \cdot j_*(v)$, for $u \otimes v \in \mathcal{U}(\mathfrak{g}) \otimes \mathcal{U}(\mathfrak{h})$. We claim that:

LEMMA 7.2.21. *The just defined morphism $\mu(i_*, j_*) : \mathcal{U}(\mathfrak{g}) \otimes \mathcal{U}(\mathfrak{h}) \rightarrow \mathcal{U}(\mathfrak{g} \oplus \mathfrak{h})$ is an iso.*

PROOF. In general, we have an bijection between the morphisms of unitary associative algebras on a tensor product $\phi : U \otimes V \rightarrow T$ and the pair of unitary associative algebra morphisms $(\phi_f : U \rightarrow T, \phi_g : V \rightarrow T)$ satisfying $[\phi_f(U), \phi_g(V)] = 0$ in T as we can set $\phi(u \otimes v) = \phi_f(u) \cdot \phi_g(v)$ to get a morphism on $U \otimes V$ when this condition is satisfied. In the case of the enveloping algebras $U = \mathcal{U}(\mathfrak{g})$ and $V = \mathcal{U}(\mathfrak{h})$, the verification of the relation $[f(\mathfrak{g}), g(\mathfrak{h})] = 0$ for the Lie algebra morphisms $(f : \mathfrak{g} \rightarrow T, g : \mathfrak{h} \rightarrow T)$ associated to $(\phi_f : \mathcal{U}(\mathfrak{g}) \rightarrow T, \phi_g : \mathcal{U}(\mathfrak{h}) \rightarrow T)$, readily implies that we have the commutation relation $[\phi_f(u), \phi_g(v)] = 0$ on the whole tensor product $\mathcal{U}(\mathfrak{g}) \otimes \mathcal{U}(\mathfrak{h})$.

Hence, giving a morphism of unitary associative algebras $\phi : \mathcal{U}(\mathfrak{g}) \otimes \mathcal{U}(\mathfrak{h}) \rightarrow T$ amounts to giving a pair of Lie algebra morphisms $(f : \mathfrak{g} \rightarrow T, g : \mathfrak{h} \rightarrow T)$ such that $[f(\mathfrak{g}), g(\mathfrak{h})] = 0$, and according to the analysis of §7.2.20, this data amounts to defining a Lie algebra morphism on the direct sum $\mathfrak{g} \oplus \mathfrak{h}$.

From this result, we conclude that the tensor product $\mathcal{U}(\mathfrak{g}) \otimes \mathcal{U}(\mathfrak{h})$ fits in the adjunction relation characterizing the enveloping algebra of the Lie algebra $\mathfrak{g} \oplus \mathfrak{h}$, and hence, is isomorphic to this enveloping algebra. The morphism considered in the lemma can readily be identified with the comparison isomorphism arising from our argument line. \square

7.2.22. *The symmetric monoidal category of Hopf algebras.* We have already observed that the category of counitary cocommutative coalgebras in any symmetric monoidal category, and the category of unitary associative algebras similarly, inherits a symmetric monoidal structure. As we define bialgebras in term of a combination of these structures, we deduce from our general primary results that the category of bialgebras inherit a symmetric monoidal structure too. When we deal with Hopf algebras $G, H \in \mathcal{H}opfGrp$, we have an obvious antipode on the tensor $G \otimes H$, defined factor-wise by the tensor product of the antipodes associated to G and H . We conclude that the category of Hopf algebras $\mathcal{H}opfGrp$ forms a symmetric monoidal subcategory of the category of bialgebras.

We implicitly check, in the proof of Lemma 7.2.21, that our pairing $\mu(i_*, j_*) : \mathbb{U}(\mathfrak{g}) \otimes \mathbb{U}(\mathfrak{h}) \rightarrow \mathbb{U}(\mathfrak{g} \oplus \mathfrak{h})$ defines a morphism of unitary associative algebras. We readily see that our morphism preserves counits and coproducts too (since this is so on the Lie algebras which generate our unitary algebra tensor product). Accordingly, our pairing defines an isomorphism of Hopf algebras.

In the formalism of symmetric monoidal categories, the result of Lemma 7.2.21 implies:

PROPOSITION 7.2.23. *The enveloping algebra functor $\mathbb{U} : \mathcal{L}ie \rightarrow \mathcal{H}opfGrp$ is symmetric monoidal in the sense that:*

- (a) *in the case of the zero object 0 , viewed as the unit object of the category of Lie algebras, we have an obvious identity $\mathbb{U}(0) = \mathbb{1}$;*
- (b) *in the case of a direct sum of Lie algebras $\mathfrak{g} \oplus \mathfrak{h}$, the pairing of §7.2.20 defines a Hopf algebra isomorphism $\mathbb{U}(\mathfrak{g}) \otimes \mathbb{U}(\mathfrak{h}) \xrightarrow{\cong} \mathbb{U}(\mathfrak{g} \oplus \mathfrak{h})$;*
- (c) *and these comparison isomorphisms fulfill the unit, associativity and symmetry constraints of §2.3.1.*

PROOF. The statement of assertion (a) is obvious and we have already checked the result of assertion (b). The proof of the unit, associativity and symmetry constraints, claimed by assertion (c), follows from a straightforward inspection of definitions. \square

7.3. Lie algebras and Hopf algebras in complete filtered modules

In this section, we examine the definition of Hopf algebras and the applications of the concepts of §§7.1-7.2 in the case where the ambient category consists of modules M equipped with a filtration $M = F_0 M \supset \cdots \supset F_s M \supset \cdots$ so that $M = \lim_s M / F_s M$. We use the expression of complete filtered module to refer to such objects. We also deal with Hopf algebras satisfying an appropriate connectedness condition when we work in the category of complete filtered modules, and will use the expression of complete Hopf algebra to refer to this more precise notion.

Our main purpose is to check that the main results of §7.2, about the relationship between Lie algebras and Hopf algebras, work well for complete Hopf algebras. We check that the category of complete filtered modules forms an example of category fitting the setting of §7.2 first. We revisit the adjunction between Lie algebras and Hopf algebras afterwards. We are notably going to observe that the universal algebra structures of §7.2, namely the free Lie, symmetric, tensor, and enveloping algebras, can be realized, in the category of complete filtered modules, as completions of the corresponding ordinary objects in the category of \mathbb{k} -modules.

Throughout this section, we assume that our ground ring \mathbb{k} is a field of characteristic zero. The assumption that \mathbb{k} is a field ensures us that the tensor product of \mathbb{k} -modules preserves monomorphisms, kernels and finite limits. Let us mention that our constructions have generalizations in the context of complete modules over a complete local ring R , like power series ring $\mathbb{k}[[t]]$, which are naturally considered in problems of deformation theory (see for instance [130] for a general reference on this subject).

We work in the category of \mathbb{k} -modules and in the categories formed by the filtered objects, complete filtered objects, and weight graded objects in this base category $\mathcal{M}od = \mathcal{M}od_{\mathbb{k}}$. We first explain the precise definition of these categories and check that they form examples of \mathbb{Q} -additive symmetric monoidal categories in the sense considered in §7.2.

7.3.1. *The category of filtered modules.* We call filtered module the structure defined by a module M equipped with a decreasing filtration of the form:

$$M = \mathbf{F}_0 M \supset \cdots \supset \mathbf{F}_s M \supset \cdots .$$

We also say that a module morphism $f : M \rightarrow N$ is filtration preserving when we have $f(\mathbf{F}_s M) \subset \mathbf{F}_s N$, for all $s \in \mathbb{N}$. We set $f\mathcal{M}od$ for the category formed by the filtered modules as objects and the filtration preserving morphisms as morphisms.

We use this category as an auxiliary category for the definition of complete filtered modules, and we will need the following constructions:

- (a) The direct sum $\bigoplus_{\alpha \in \mathcal{J}} M_\alpha$ of filtered modules M_α , $\alpha \in \mathcal{J}$, inherits a canonical filtration, defined by the obvious formula $\mathbf{F}_s(\bigoplus_{\alpha} M_\alpha) = \bigoplus_{\alpha} \mathbf{F}_s(M_\alpha)$, and represents the coproduct of the objects M_α , $\alpha \in \mathcal{J}$, in the category of filtered modules. The category of filtered modules is obviously additive, so that we have an identity between finite direct and cartesian products of filtered modules.
- (b) A submodule $K \subset M$ of a filtered module M inherits a canonical filtration, defined by $\mathbf{F}_s K = K \cap \mathbf{F}_s M$, and to which we refer as the induced filtration on K . We easily see that the kernel $K = \ker(f)$ of a filtration preserving morphism $f : M \rightarrow N$, $M, N \in f\mathcal{M}od$, equipped with this induced filtration, represents the kernel of the morphism f in the category of filtered modules.
- (c) A quotient N/M of a filtered module N by a submodule M is also equipped with a canonical filtration, defined by $\mathbf{F}_s(N/M) = \mathbf{F}_s(N)/M \cap \mathbf{F}_s(N)$. We easily see that this quotient filtered module N/M represents the cokernel of the canonical embedding $i : M \hookrightarrow N$ in the category of filtered modules. In general, the cokernel of a morphism $f : M \rightarrow N$ in the category of filtered modules can be realized as the quotient filtered module $N/f(M)$, where we regard the image of our morphism $f(M) \subset N$ as a submodule of the codomain N .

The existence of coproducts and cokernels implies that the category of filtered modules has all colimits. Recall that, in an additive category, the cokernel of a parallel pair (d_0, d_1) is identified with the cokernel of the difference $d_0 - d_1$.

The observations (b) imply that the monomorphisms of the category of filtered modules are the filtration preserving morphisms $i : M \rightarrow N$ which are injective as module morphisms. In general, the preservation of filtrations by a morphism $i : M \rightarrow N$ is equivalent to the relation $i(\mathbf{F}_s M) \subset \mathbf{F}_s N \Leftrightarrow \mathbf{F}_s M \subset i^{-1}(\mathbf{F}_s N)$.

We say that a monomorphism of filtered modules $i : M \rightarrow N$ is a filtered module inclusion, and we write $i : M \hookrightarrow N$, when we have an equality in this relation $F_s M = i^{-1}(F_s N)$, so that we can identify the subobject M with a submodule of N equipped with the induced filtration, as defined in (b).

Note that a monomorphism of filtered modules is not necessarily a filtered module inclusion, and hence, a kernel in the category of filtered modules. This observation immediately proves that the category of filtered modules, though additive, fails to be abelian. Note also that a morphism of filtered modules which is bijective as a module morphism is not an isomorphism in the category of filtered modules in general. The isomorphisms of the category of filtered modules precisely consist of the filtration preserving morphisms $f : M \rightarrow N$ which are bijective as module morphisms and of which inverse bijection $f^{-1} : N \rightarrow M$ is also filtration preserving.

7.3.2. *Towers.* We immediately see that giving a filtration in §7.3.1 amounts to giving a coaugmented tower of surjections of the form

$$M \twoheadrightarrow \cdots \twoheadrightarrow M/F_s M \twoheadrightarrow \cdots \twoheadrightarrow M/F_0 M = 0 ,$$

since we have $p_s M = M/F_s M \Leftrightarrow F_s M = \ker(M \rightarrow p_s M)$. We refer to the quotient $p_s M = M/F_s M$ occurring in this tower as the s th level of the tower associated to the filtered module M . We also have an equivalence between the morphisms of filtered modules and the morphisms of coaugmented towers, which formally consist of an underlying module morphism $f : M \rightarrow N$ together with a sequence of fill-in morphisms

$$\begin{array}{ccccccc} M & \twoheadrightarrow & \cdots & \twoheadrightarrow & M/F_s M & \twoheadrightarrow & \cdots & \twoheadrightarrow & M/F_0 M . \\ \downarrow f & & & & \downarrow f_* & & & & \downarrow f_* \\ N & \twoheadrightarrow & \cdots & \twoheadrightarrow & N/F_s N & \twoheadrightarrow & \cdots & \twoheadrightarrow & N/F_0 N \end{array}$$

In this equivalence, the isomorphisms of the category of filtered modules correspond to the morphisms of coaugmented towers which form an isomorphism level-wise.

We mainly use the tower representation when we define the completion of filtered modules (in the next paragraph). In the tower representation, we can easily realize colimits by an obvious level-wise construction, and we can see that the filtration constructions of §7.3.1 match this process. For our purpose, we record the following observations:

- (a) For a direct sum $\bigoplus_{\alpha \in \mathcal{J}} M_\alpha$ of filtered modules M_α , $\alpha \in \mathcal{J}$, we have an obvious identity:

$$\left(\bigoplus_{\alpha \in \mathcal{J}} M_\alpha \right) / F_s \left(\bigoplus_{\alpha \in \mathcal{J}} M_\alpha \right) = \bigoplus_{\alpha \in \mathcal{J}} (M_\alpha / F_s M_\alpha),$$

for each $s \in \mathbb{N}$.

- (b) For a submodule $K \subset M$ of a filtered module M , which we equip with the induced filtration of §7.3.1(b), we have a tower identity $K/F_s K = K/K \cap F_s M$, and the inclusion $K \subset M$ induces an embedding

$$K/K \cap F_s M \hookrightarrow K/F_s M,$$

for each $s \in \mathbb{N}$. For the kernel $K = \ker(f)$ of a filtration preserving morphism $f : M \rightarrow N$, we have the relation

$$\ker(f)/\ker(f) \cap \mathbf{F}_s M = \ker(f_* : M/\mathbf{F}_s M \rightarrow N/\mathbf{F}_s N),$$

at each level $s \in \mathbb{N}$.

- (c) For the quotient N/M of a complete filtered module N by a submodule M , where we consider the quotient filtration of §7.3.1(c), we have a short exact sequence

$$0 \rightarrow M/M \cap \mathbf{F}_s N \rightarrow N/\mathbf{F}_s N \rightarrow (N/M)/\mathbf{F}_s(N/M) \rightarrow 0,$$

for each $s \in \mathbb{N}$.

The proof of these observations reduces to easy verifications.

7.3.3. *Completions.* The completion of a filtered module M is the module \hat{M} such that $\hat{M} = \lim_s M/\mathbf{F}_s M$. The tower of quotient morphisms $q : M \rightarrow M/\mathbf{F}_s M$ gives rise to a canonical morphism $q : M \rightarrow \hat{M}$ towards this limit $\hat{M} = \lim_s M/\mathbf{F}_s M$. The module \hat{M} inherits a canonical filtration, defined by the kernels

$$\mathbf{F}_s \hat{M} = \ker(\hat{M} \rightarrow M/\mathbf{F}_s M),$$

where we consider the canonical projections $\hat{M} \rightarrow M/\mathbf{F}_s M$, $s \in \mathbb{N}$, associated with the limit $\hat{M} = \lim_s M/\mathbf{F}_s M$. Our canonical morphism $q : M \rightarrow \hat{M}$ is clearly filtration preserving. The construction of this object \hat{M} , together with the associated morphism $q : M \rightarrow \hat{M}$, is obviously functorial in $M \in f\mathcal{M}od$.

In the language of §7.3.2, the definition $\mathbf{F}_s \hat{M} = \ker(\hat{M} \rightarrow M/\mathbf{F}_s M)$ amounts to providing the completed module \hat{M} with the filtration associated to the tower

$$\hat{M} \twoheadrightarrow \dots \twoheadrightarrow M/\mathbf{F}_s M \twoheadrightarrow \dots \twoheadrightarrow M/\mathbf{F}_0 M = 0$$

used to define this limit, so that we have an identity:

$$\hat{M}/\mathbf{F}_s \hat{M} = M/\mathbf{F}_s M,$$

for every $s \in \mathbb{N}$. This tower identity implies that the completion functor is idempotent in the sense that the canonical morphism $q : N \rightarrow \hat{N}$ associated to a completed module $N = \hat{M}$ is an iso.

In general, we say that a filtered module M is complete when the associated morphism $q : M \rightarrow \hat{M}$ is an iso (equivalently, if we have $M = \lim_s M/\mathbf{F}_s(M)$). The idempotence of the completion functor implies that the completion of a filtered module M gives a complete filtered module \hat{M} , naturally associated to M . This complete filtered module \hat{M} is also universal in the sense that any filtration preserving morphism $f : M \rightarrow N$, where N is complete, admits a unique factorization

$$\begin{array}{ccc} M & \xrightarrow{f} & N \\ & \searrow q & \nearrow \hat{f} \\ & \hat{M} & \end{array}$$

in the category of filtered modules (we take the image of the morphism f under the completion functor, and use the identity $N = \hat{N}$ to get this factorization).

7.3.4. *The category of complete filtered modules.* The category formed by the complete filtered modules as objects and the filtration preserving morphisms as morphisms is denoted by $\widehat{\mathcal{M}od}$ (we forget about the f prefix in this notation, because we assume that a complete filtered module is automatically given with a fixed filtration). The completion functor can be interpreted as a left adjoint of the category embedding $i : \widehat{\mathcal{M}od} \hookrightarrow f\mathcal{M}od$.

$\widehat{\mathcal{M}od} = \widehat{f\mathcal{M}od}$
in revised
versions of
this work

In what follows, we use a notation of the form $\widehat{\text{colim}}_{\alpha} M_{\alpha}$, with a hat mark, to distinguish the colimit of a diagram M_{α} , $\alpha \in \mathcal{J}$, in the category complete filtered modules $\widehat{\mathcal{M}od}$ from the colimit of this diagram $\text{colim}_{\alpha} M_{\alpha}$ in the category of filtered modules $f\mathcal{M}od$, which we also use as an auxiliary construction in the complete setting. The idempotence of the completion functor actually implies that the complete colimit $\widehat{\text{colim}}_{\alpha} M_{\alpha}$ can be realized as a completion of the ordinary colimit $(\text{colim}_{\alpha} M_{\alpha})^{\widehat{}}$. This observation implies that the category of complete filtered modules has all colimits too. In general, for a diagram in the category of filtered modules M_{α} , $\alpha \in \mathcal{J}$, we have an identity

$$(\text{colim}_{\alpha} M_{\alpha})^{\widehat{}} = \widehat{\text{colim}}_{\alpha} \hat{M}_{\alpha}$$

in the category of complete filtered modules.

For our purpose, we record the following assertions concerning particular cases of colimit and limit constructions (we rely on the observations of §7.3.2 for the verification of these claims):

- (a) For the direct sum of a finite collection of filtered modules M_{α_i} , $i = 1, \dots, n$, we have an obvious relation

$$(M_{\alpha_1} \oplus \dots \oplus M_{\alpha_n})^{\widehat{}} = \hat{M}_{\alpha_1} \oplus \dots \oplus \hat{M}_{\alpha_n}.$$

In the case of complete filtered modules $M_{\alpha_i} = \hat{M}_{\alpha_i}$ we deduce from this identity that the direct sum $M_{\alpha_1} \oplus \dots \oplus M_{\alpha_n}$ is complete, and we obtain, besides, that this direct sum represents the coproduct of the objects M_{α_i} , $i = 1, \dots, n$, in the category of complete filtered modules. The category of complete filtered modules is therefore additive (like the category of filtered modules). For the direct sum $\bigoplus_{\alpha \in \mathcal{J}} M_{\alpha}$ of a (possibly infinite) collection of filtered modules M_{α} , $\alpha \in \mathcal{J}$, the completion returns a complete filtered module $(\bigoplus_{\alpha \in \mathcal{J}} M_{\alpha})^{\widehat{}}$ which represents the coproduct of the objects \hat{M}_{α} in the category of complete filtered modules. By convention, we may use the notation $\widehat{\bigoplus}_{\alpha \in \mathcal{J}} M_{\alpha}$ (with the hat mark) to refer to these coproducts in the complete sense.

- (b) Let $K \subset M$ be a submodule of a filtered module M , which we equip with the induced filtration of §7.3.1(b). The morphism of complete filtered modules $\hat{K} \rightarrow \hat{M}$ extending the inclusion $i : K \hookrightarrow M$ is an inclusion of filtered modules. The kernel $\ker(f)$ of a filtration preserving morphism $f : M \rightarrow N$, equipped with the induced filtration, is automatically complete as soon as M and N are complete, and represents the kernel of the morphism f in the category of complete filtered modules. In general, we have the relation

$$\ker(f)^{\widehat{}} = \ker(\hat{f} : \hat{M} \rightarrow \hat{N}),$$

where $\hat{f} : \hat{M} \rightarrow \hat{N}$ is the morphism of complete filtered modules induced by our morphism $f : M \rightarrow N$.

- (c) For the quotient N/M of a filtered module N by a submodule M , equipped with the quotient filtration of §7.3.1(c), we have the relation

$$(N/M)^\wedge = \hat{N}/\hat{M},$$

where we use the observation of assertion (b) to identify the completion \hat{M} with a submodule of the complete filtered module \hat{N} . In particular, the quotient of a complete filtered module $N = \hat{N}$ by a complete submodule $M = \hat{M}$ is automatically complete. The object $(N/M)^\wedge$ represents the cokernel of the inclusion $\hat{M} \hookrightarrow \hat{N}$ in the category of complete filtered modules. In general, the cokernel of a morphism $\hat{f} : \hat{M} \rightarrow \hat{N}$ in the category of complete filtered modules can be identified with the completion $(N/f(M))^\wedge$, where we regard the image of our morphism $f(M) \subset N$ as a submodule of the codomain N .

We can easily observe that the category of complete filtered modules, though additive, fails to be abelian (for the same reasons as the category of plain filtered modules). In the next paragraph, we recall the definition of weight graded module structures, which we use as approximations of our complete filtered modules, and which do form an abelian category. The idea is to use abelian category methods at this level in order to get structure results for complete filtered modules.

7.3.5. *The category of weight graded modules.* The category of weight graded modules, denoted by $w\text{Mod}$, consists of the modules M equipped with a decomposition of the form $M = \bigoplus_{s \in \mathbb{N}} M_s$, and where we refer to the summand M_s as the homogeneous component of weight s of the module M . The morphisms of this category are the module morphisms $f : M \rightarrow N$ which preserve the weight decomposition in the sense that $f(M_s) \subset N_s$. The definition of a weight graded module is obviously the same as the definition of a graded module of §4.4 (except that we now restrict the grading to non-negative integers). But we introduce a new category in order to distinguish structures of different nature. This difference appears, at the categorical level, in the definition of a symmetric monoidal structure on weight graded modules (see §7.3.13).

The category of weight graded modules inherits both limits and colimits (realized componentwise) and is also clearly abelian (unlike the category of filtered modules and the category of filtered modules).

7.3.6. *The weight graded module associated to a filtered module.* To a filtered module M we associate a weight graded module $E^0 M$ with the sub-quotients

$$E_s^0 M = F_s M / F_{s+1} M, \quad \text{for } s \in \mathbb{N},$$

as homogeneous components. The mapping $E^0 : M \mapsto E^0 M$ defines a functor on the category of filtered modules and on the category of complete filtered modules as well by restriction.

The sub-quotients $E_s^0 M$ can also be defined in terms of the tower associated to M . We explicitly have:

$$E_s^0 M = \ker(M / F_{s+1} M \rightarrow M / F_s M), \quad \text{for } s \in \mathbb{N}.$$

For the completion of a filtered module \hat{M} , we immediately deduce from this representation that we have the relation:

$$E_s^0 \hat{M} = E_s^0 M,$$

for every $s \in \mathbb{N}$.

The following easy statement motivates the introduction of weight graded modules for the study of complete filtered modules:

PROPOSITION 7.3.7. *A morphism of complete filtered modules $f : M \rightarrow N$ is an iso as soon as the associated morphism of weight graded modules $\mathbf{E}^0 f : \mathbf{E}^0 M \rightarrow \mathbf{E}^0 N$ is an iso in $w\text{Mod}$.*

PROOF. The definition $\mathbf{E}_s^0 M = \ker(M/\mathbf{F}_{s+1}M \rightarrow M/\mathbf{F}_sM)$ implies that the modules of homogeneous weight $\mathbf{E}_s^0 M$ fit in short exact sequences

$$0 \rightarrow \mathbf{E}_s^0 M \rightarrow M/\mathbf{F}_{s+1}M \rightarrow M/\mathbf{F}_sM \rightarrow 0,$$

for all $s \in \mathbb{N}$. From these exact sequences, we obtain by induction that a morphism of filtered modules $f : M \rightarrow N$ induces an isomorphism at each level s of the towers associated to our modules as soon as the morphism of weight graded modules $\mathbf{E}^0 f : \mathbf{E}^0 M \rightarrow \mathbf{E}^0 N$ is an iso. The proposition follows. \square

In subsequent verifications, we combine the result of this proposition with the following observations:

PROPOSITION 7.3.8. *The mapping $\mathbf{E}^0 : M \mapsto \mathbf{E}^0 M$ preserves the categorical operations considered in §7.3.1(a-c). To be explicit, we have the following assertions:*

- (a) *For a direct sum $\bigoplus_{\alpha} M_{\alpha}$ of (complete) filtered modules M_{α} , we have the obvious relation*

$$\mathbf{E}^0\left(\bigoplus_{\alpha} M_{\alpha}\right) = \bigoplus_{\alpha} \mathbf{E}^0 M_{\alpha}.$$

- (b) *For the kernel $K = \ker(f : M \rightarrow N)$ of a filtration preserving morphism $f : M \rightarrow N$, where M and N are (complete) filtered modules, we have the relation*

$$\mathbf{E}^0 \ker(f : M \rightarrow N) = \ker(\mathbf{E}^0 f : \mathbf{E}^0 M \rightarrow \mathbf{E}^0 N).$$

- (c) *For a submodule $M \subset N$ of a filtered module N , equipped with the induced filtration of §7.3.1(b), the weight graded module $\mathbf{E}^0 M$ associated to M embeds into $\mathbf{E}^0 N$, and we have a short exact sequence*

$$0 \rightarrow \mathbf{E}^0 M \rightarrow \mathbf{E}^0 N \rightarrow \mathbf{E}^0(N/M) \rightarrow 0$$

identifying $\mathbf{E}^0 M/\mathbf{E}^0 N$ with the weight graded module $\mathbf{E}^0(N/M)$, where the module N/M is equipped with the quotient filtration of §7.3.1(c).

PROOF. The proof of this proposition reduces to easy verifications which elaborate on the observations of §7.3.2. \square

7.3.9. The tensor product of filtered modules. The tensor product $M \otimes N$ of filtered modules $M, N \in f\text{Mod}$ inherits a canonical filtration, which we define by:

$$\mathbf{F}_r(M \otimes N) = \sum_{s+t=r} \mathbf{F}_s(M) \otimes \mathbf{F}_t(N) \subset M \otimes N, \quad \text{for each } r \in \mathbb{N}.$$

The category of filtered modules is therefore equipped with a natural tensor product operation.

The ground field \mathbb{k} , regarded as a module equipped with a trivial filtration, such that $\mathbf{F}_0 \mathbb{k} = \mathbb{k}$ and $\mathbf{F}_s \mathbb{k} = 0$ for $s > 0$, forms a unit for this tensor product. Besides, we readily check that the associativity isomorphism $(K \otimes L) \otimes M \simeq K \otimes (L \otimes M)$ preserves filtrations, so that the associativity of the tensor product holds in the

category of filtered modules, and we also have a symmetry isomorphism $M \otimes N \simeq N \otimes M$ inherited from the base category of \mathbb{k} -modules. Thus we have a natural symmetric monoidal structure on the category of filtered modules. We readily see, moreover, that the tensor product of filtered modules preserves the direct sums of §7.3.1(a), the cokernels of §7.3.1(c), and as a consequence all colimits, so that the colimit preservation requirement of §0.9 is entirely satisfied in the category of filtered modules.

We use the symmetric monoidal category of filtered modules as an auxiliary structure for the definition of a symmetric monoidal structure on complete filtered modules. The tensor product of complete filtered modules is not complete in general. For $M, N \in \widehat{\mathcal{M}od}$, we therefore perform the completion operation

$$M \hat{\otimes} N = \varinjlim_r (M \otimes N) / \mathbf{F}_r(M \otimes N)$$

in order to get a tensor product operation $\hat{\otimes}$ on the category of complete filtered modules. Our purpose is to establish that the category of complete filtered modules, equipped with this completed tensor product, is symmetric monoidal. Our verifications rely on the following observation:

LEMMA 7.3.10. *The natural morphism*

$$\begin{aligned} \bigoplus_{s+t=r} \underbrace{\mathbf{F}_s M / \mathbf{F}_{s+1} M}_{=\mathbf{E}_s^0 M} \otimes \underbrace{\mathbf{F}_t N / \mathbf{F}_{t+1} N}_{=\mathbf{E}_t^0 N} \\ \rightarrow \underbrace{\sum_{s+t=r} \mathbf{F}_s(M) \otimes \mathbf{F}_t(N) / \sum_{s+t=r+1} \mathbf{F}_s(M) \otimes \mathbf{F}_t(N)}_{=\mathbf{E}_r^0(M \otimes N)} \end{aligned}$$

is an iso.

PROOF. The proof of this lemma reduces to an elementary exercise of linear algebra. \square

This lemma gives our main argument in the proof of the following proposition:

PROPOSITION 7.3.11. *The canonical morphism $M \otimes N \rightarrow \hat{M} \otimes \hat{N} \rightarrow \hat{M} \hat{\otimes} \hat{N}$, defined for any pair of filtered modules $M, N \in f\mathcal{M}od$, extends to an isomorphism*

$$(M \otimes N)^\wedge \xrightarrow{\cong} \hat{M} \hat{\otimes} \hat{N}$$

in the category of complete filtered modules.

PROOF. Lemma 7.3.10 implies that we have

$$\mathbf{E}_r^0(M \otimes N)^\wedge = \mathbf{E}_r^0(M \otimes N) = \bigoplus_{s+t=r} \mathbf{E}_s^0 M \otimes \mathbf{E}_t^0 N$$

as well as

$$\mathbf{E}_r^0(\hat{M} \hat{\otimes} \hat{N}) = \mathbf{E}_r^0(\hat{M} \otimes \hat{N}) = \bigoplus_{s+t=r} \mathbf{E}_s^0 \hat{M} \otimes \mathbf{E}_t^0 \hat{N} = \bigoplus_{s+t=r} \mathbf{E}_s^0 M \otimes \mathbf{E}_t^0 N$$

for every $r \in \mathbb{N}$. Besides, we immediately see that the morphism of the proposition $(M \otimes N)^\wedge \rightarrow \hat{M} \hat{\otimes} \hat{N}$ induces the identity morphism at the level of these weight graded modules. Proposition 7.3.7 immediately implies, therefore, that this morphism is an isomorphism. \square

In the next paragraphs §§7.3.12-7.3.13, we reinterpret these intermediate results as the definition of symmetric monoidal functors between the symmetric monoidal categories formed by the filtered modules, the complete filtered modules and the weight graded modules.

7.3.12. *The symmetric monoidal structure on the category of complete filtered modules.* We equip the category of complete filtered modules with the completed tensor product of §7.3.9:

$$M \hat{\otimes} N = M \otimes N / \mathbf{F}_r(M \otimes N).$$

We see that the ground field, for which we have $\hat{\mathbb{k}} = \mathbb{k}$, also defines a unit for this tensor structure. We moreover readily obtain, from the result of Proposition 7.3.11, that the completed tensor product inherits an associativity isomorphism from the tensor product of filtered modules:

$$((K \hat{\otimes} L) \hat{\otimes} M) \simeq ((K \otimes L) \otimes M)^\wedge \simeq (K \otimes (L \otimes M))^\wedge \simeq (K \hat{\otimes} (L \hat{\otimes} M)).$$

We also have an obvious symmetry isomorphism $M \hat{\otimes} N \simeq N \hat{\otimes} M$ induced by the symmetry isomorphism of the category of filtered modules (we just use the functoriality of completions in this case). Thus the category of complete filtered modules $\widehat{\mathcal{M}od}$, equipped with our completed tensor product $\hat{\otimes}$, has a full symmetric monoidal category structure. From the realization of colimits of complete filtered modules in terms of completions (see §7.3.4), the result of Proposition 7.3.11, and the preservation of colimits by the tensor product of filtered modules (see §7.3.9), we obtain that the colimit preservation axiom of §0.9 is fulfilled in the category of complete filtered modules as well.

We can interpret the result Lemma 7.3.10, in terms of a symmetric monoidal structure on weight graded modules, of which we now explain the definition. Simply note, before addressing this subject, that the result of Proposition 7.3.11 and the definition of our symmetric monoidal structure on complete filtered modules, implies that the completion functor $(-)^{\wedge}: f\mathcal{M}od \rightarrow \widehat{\mathcal{M}od}$ is symmetric monoidal.

7.3.13. *The symmetric monoidal structure on the category of weight graded modules.* The tensor product of weight graded module $M, N \in w\mathcal{M}od$ inherits a canonical weight decomposition $M \otimes N = \bigoplus_{r=0}^{\infty} (M \otimes N)_r$, which we define by the same formula as in the homological algebra framework (see §4.4):

$$(M \otimes N)_r = \bigoplus_{s+t=r} M_s \otimes N_t, \quad \text{for } r \in \mathbb{N}.$$

The category of weight graded modules is therefore equipped with a natural tensor product operation $\otimes : w\mathcal{M}od \times w\mathcal{M}od \rightarrow w\mathcal{M}od$ (given by the same construction as the tensor product of graded modules in §4.4.1). The ground ring \mathbb{k} , regarded as weight graded module of rank 1 concentrated in weight $r = 0$, still provides a unit object for this tensor product, and we have an obvious associativity isomorphisms yet. But, in contrast with the definition of §4.4.1, we now consider the plain symmetry isomorphism of the category of \mathbb{k} -modules $M_s \otimes N_t \simeq N_t \otimes M_s$ (with no sign involved) to define a symmetry isomorphism for the tensor product of weight graded modules.

The tensor product of weight graded modules clearly fully satisfies the colimit preservation requirement of §0.9.

The result of Lemma 7.3.10 amounts to the definition of a weight-graded module isomorphism

$$\mathbf{E}^0(M \otimes N) \simeq \mathbf{E}^0(M) \otimes \mathbf{E}^0(N)$$

and we have an analogous iso in the complete case, since the definition of the tensor product $M \hat{\otimes} N$ as a completion implies $\mathbf{E}^0(M \hat{\otimes} N) = \mathbf{E}^0(M \otimes N)$ (see §7.3.6). The mapping $\mathbf{E}^0 : M \mapsto \mathbf{E}^0(M)$ clearly preserves unit objects, our iso satisfies the associativity constraint of §2.3.1, as well as the commutativity constraint. To be explicit, the morphism $\mathbf{E}^0(M \otimes N) \simeq \mathbf{E}^0(M \otimes N)$ induced by the symmetry isomorphism of filtered modules is carried to the plain symmetry isomorphism of the category of weight graded modules $\mathbf{E}^0(M) \otimes \mathbf{E}^0(N) \simeq \mathbf{E}^0(M) \otimes \mathbf{E}^0(N)$ (of which definition was actually motivated by this correspondence) when we apply our symmetric monoidal transformation. Thus, the mapping $\mathbf{E}^0 : M \mapsto \mathbf{E}^0(M)$ defines a symmetric monoidal functor from the category of filtered modules (respectively, the category of complete filtered modules) towards the category of weight graded modules.

7.3.14. *Hopf algebras in filtered, complete and weight graded modules.* The definition of the symmetric monoidal structures, in the previous paragraphs, enables us to apply concepts of the previous sections §§7.1-7.2 in the context of filtered modules, complete filtered modules, and weight graded modules. In particular, we can define Hopf algebra structures in these categories.

In the weight graded setting, the definition of such a Hopf algebra H explicitly amounts to assuming that we have a weight graded module H together with a Hopf algebra structure (in the ordinary sense) so that the unit $\eta : \mathbb{k} \rightarrow H$, the product $\mu : H \otimes H \rightarrow H$, the counit $\epsilon : H \rightarrow \mathbb{k}$, the coproduct $\Delta : H \rightarrow H \otimes H$, and the antipode $\sigma : H \rightarrow H$ are homogeneous morphisms. In the filtered module setting, we similarly obtain that a Hopf algebra H consists of a filtered module H together with a Hopf algebra structure (in the ordinary sense) so that the unit $\eta : \mathbb{k} \rightarrow H$, the product $\mu : H \otimes H \rightarrow H$, the counit $\epsilon : H \rightarrow \mathbb{k}$, the coproduct $\Delta : H \rightarrow H \otimes H$, and the antipode $\sigma : H \rightarrow H$ are filtration preserving morphisms.

In the complete case, we have to replace the plain tensor product by the completed one $\hat{\otimes}$ in the definition of a Hopf algebra. The product can still be composed with the canonical morphism $H \otimes H \rightarrow H \hat{\otimes} H$ (associated to our completion) to give an ordinary product on the Hopf algebra H (we go back to this observation in §7.3.21). In contrast, the coproduct $\Delta : H \rightarrow H \hat{\otimes} H$ does not factor through the ordinary tensor product in general, and accordingly, is not equivalent to an ordinary coproduct.

The preservation of symmetric monoidal structures implies that the filtration subquotient functor $\mathbf{E}^0 : M \mapsto \mathbf{E}^0 M$ maps a Hopf algebra in filtered modules (respectively, in complete filtered modules) to a Hopf algebra in weight graded modules. The completion functor $(-)^{\wedge} : M \mapsto \hat{M}$ similarly maps a Hopf algebra in filtered modules to a Hopf algebra in complete filtered modules.

7.3.15. *Connected weight graded Hopf algebras and complete Hopf algebras.* In order to agree with standard conventions (see [138]), we say that a weight graded Hopf algebra (for a Hopf algebra in weight graded modules) is connected when we have $H_0 = \mathbb{k}$. The unit $\eta : \mathbb{k} \rightarrow H$ (respectively, the counit $\epsilon : H \rightarrow \mathbb{k}$) is necessarily given, in this case, by the identity morphism between the ground field \mathbb{k} and the component H_0 . We use the notation $w\mathcal{HopfGrp}_1$ for the category formed by the connected weight graded Hopf algebras.

In the filtered module context, we analogously say that a filtered Hopf algebra (for a Hopf algebra in filtered modules) is connected when we have $E_0^0 H = H/F_1 H = \mathbb{k}$, and we use the notation $f\mathcal{H}opf\mathcal{G}rp_1$ for this subcategory of the category of Hopf algebras in filtered modules. In the case of Hopf algebras in complete filtered modules, we suppose that the requirement $E_0^0 H = \mathbb{k}$ is satisfied in all applications. Therefore we reserve the expression of complete Hopf algebra and we use the notation $\widehat{\mathcal{H}opf\mathcal{G}rp}$ (with no further precision) for the subcategory of Hopf algebras in complete filtered modules that satisfy our condition $E_0^0 H = \mathbb{k}$.

$\widehat{\mathcal{H}opf\mathcal{G}rp} = \widehat{\mathcal{H}opf\mathcal{G}rp}$
in new versions of this work

The requirement $H/F_1 H = \mathbb{k}$ amounts to defining the category of connected filtered (respectively, complete) Hopf algebras as the counter-image of the category connected weight graded Hopf algebras under the mapping $E^0 : H \mapsto E^0 H$, and we accordingly have a diagram of functors

$$\begin{array}{ccc}
 f\mathcal{H}opf\mathcal{G}rp_1 & \xrightarrow{(-)^\wedge} & \widehat{\mathcal{H}opf\mathcal{G}rp} \\
 \searrow^{E^0} & & \swarrow_{E^0} \\
 & w\mathcal{H}opf\mathcal{G}rp_1 &
 \end{array}$$

summarizing the connections between our Hopf algebra categories.

The following proposition motivates the introduction of the connectedness condition for weight graded Hopf algebras:

PROPOSITION 7.3.16. *The connected weight graded Hopf algebras are locally conilpotent in the sense of the definition of §7.2.15.*

PROOF. Let H be a connected weight graded Hopf algebra. We check that the conditions of local conilpotence hold for the objects $K^m = H_0 \oplus \dots \oplus H_m$. We obviously have $\text{colim}_m K^m = H$ and the homogeneity of the coproduct implies the inclusion relation $\Delta(K^m) \subset \sum_{p+q=m} K_p \otimes K_q$. We are therefore reduced to check the vanishing condition $n > m \Rightarrow \pi^{(n)}\Delta^{(n)}(K^m) = 0$.

Recall that the morphism $\pi^{(n)}\Delta^{(n)}$ represents the components of the n -fold coproduct $\Delta^{(n)} : H \rightarrow H^{\otimes n}$ on the summand $\mathbb{1}(H)^{\otimes n} \subset H^{\otimes n}$. In the case of a connected weight graded Hopf algebra, for which we have $H_0 = \mathbb{k}$, the augmentation ideal $\mathbb{1}(H) = \ker(\epsilon : H \rightarrow \mathbb{k})$ is identified with the sum $\mathbb{1}(H) = \bigoplus_{r>0} H_r$. The reduced n -fold coproduct $\pi^{(n)}\Delta^{(n)}$ is equivalently defined by dropping all terms involving at least one unit factor $1 \in H_0$ in the expansion of the n -fold coproduct of an element $u \in H$. The preservation of the grading by the coproduct implies

$$\pi^{(n)}\Delta^{(n)}(H_r) \subset \bigoplus_{\substack{r_1+\dots+r_n=r \\ r_1, \dots, r_n > 0}} H_{r_1} \otimes \dots \otimes H_{r_n},$$

and we accordingly have $n > r \Rightarrow \pi^{(n)}\Delta^{(n)}(H_r) = 0$. This observation finishes the proof of our statement. \square

7.3.17. *Weight graded Lie algebras and Hopf algebras.* We can formally apply the definitions and constructions of §7.2 to the category of weight graded modules $\mathcal{M} = w\mathcal{M}od$ since this symmetric monoidal category fulfills all our requirements, including the colimit preservation condition of §0.9. We accordingly have a category of weight graded Lie algebras (for Lie algebras in weight graded modules), an enveloping algebra functor which assigns a weight graded Hopf algebra $\mathbb{U}(\mathfrak{g})$

to any weight graded Lie algebra \mathfrak{g} , as well as a primitive element functor $\mathbb{P}(H)$ which forms a right adjoint of this enveloping algebra functor on weight graded Lie algebras. We basically get all constructions by plugging in the tensor product of weight graded modules in the definitions of §7.2. We also have, by the way, a weight graded version of the symmetric Lie algebras $\mathbb{S}(M)$, of the tensor algebras $\mathbb{T}(M)$, and of the free Lie algebras $\mathbb{L}(M)$ of §§7.2.3-7.2.4.

We immediately get, from the formal definition, that a weight graded Lie algebra consists of a weight graded module \mathfrak{g} equipped with a morphism $\lambda : \mathfrak{g} \otimes \mathfrak{g} \rightarrow \mathfrak{g}$, which defines a Lie structure (in the ordinary sense) on \mathfrak{g} , and is homogenous with respect to the weight grading. We explicitly have $[\mathfrak{g}_s, \mathfrak{g}_t] \subset \mathfrak{g}_{s+t}$, for all $s, t \in \mathbb{N}$, where we use the Lie bracket notation $[x, y] = \lambda(x \otimes y)$. We say that a weight graded Lie algebra is connected when we have $\mathfrak{g}_0 = 0$, and we use the notation $w\mathcal{L}ie_0$ for this subcategory of the category of weight graded Lie algebras. We readily see that the enveloping algebra functor maps a connected weight graded Lie algebra to a connected weight graded Hopf algebra (in the sense of §7.3.15) and conversely as regards primitive elements. We accordingly have adjoint functors between our subcategories of connected objects $\mathbb{U} : w\mathcal{L}ie_0 \rightleftarrows w\mathcal{H}opf\mathcal{G}rp_1 : \mathbb{P}$, and the result of Proposition 7.2.23, asserting that the enveloping algebra functor is symmetric monoidal, holds in the weight graded setting. We also immediately see, by the way, that the symmetric algebra $R = \mathbb{S}(M)$ associated to a weight graded module $M \in w\mathcal{M}od$ is connected in the sense that $R_0 = \mathbb{k}$ when $M_0 = 0$. We have a similar result $M_0 = 0 \Rightarrow \mathbb{T}(M)_0 = \mathbb{k}$ for the tensor algebra $R = \mathbb{T}(M)$, and we obtain $M_0 = 0 \Rightarrow \mathbb{L}(M)_0 = 0$ for the free Lie algebra $R = \mathbb{L}(M)$.

We record the following weight graded version of the main theorems of §7.2:

THEOREM 7.3.18. *In the weight graded context:*

- (a) *The result of Theorem 7.2.16 (the Structure Theorem of Hopf algebras) returns an iso of weight graded counitary cocommutative coalgebras*

$$e : \mathbb{S}\mathbb{P}(H) \xrightarrow{\cong} H$$

for any connected weight graded Hopf algebra $H \in w\mathcal{H}opf\mathcal{G}rp_1$.

- (b) *The result of Theorem 7.2.17 (the Poincaré-Birkhoff-Witt Theorem) returns an iso of weight graded counitary cocommutative coalgebras*

$$e : \mathbb{S}(\mathfrak{g}) \xrightarrow{\cong} \mathbb{U}(\mathfrak{g})$$

for any connected weight graded Lie algebra $\mathfrak{g} \in w\mathcal{L}ie_0$.

- (c) *The result of Theorem 7.2.19 (the Milnor-Moore Theorem) implies that the graded versions of the enveloping algebra $\mathbb{U} : \mathfrak{g} \mapsto \mathbb{U}(\mathfrak{g})$ and primitive element functors $\mathbb{P} : H \mapsto \mathbb{P}(H)$, induce adjoint equivalences of categories*

$$\mathbb{U} : w\mathcal{L}ie_0 \rightleftarrows w\mathcal{H}opf\mathcal{G}rp_1 : \mathbb{P}$$

between the category of connected weight graded Lie algebras $w\mathcal{L}ie_0$ and the category of connected weight graded Hopf algebras $w\mathcal{H}opf\mathcal{G}rp_1$.

The third assertion of this theorem actually gives the original version of the Milnor-Moore theorem (see [138]).

PROOF. These assertions are applications of the results of Theorem 7.2.16, Theorem 7.2.17 and Theorem 7.2.19 since we established in Proposition 7.3.16 that the connected weight graded Hopf algebras are locally conilpotent in the sense of §7.2.15. \square

We now review the applications of the concepts of §7.2 in the category of complete filtered modules. We can formally apply the definitions and constructions of §7.2 in this context since we observed in §7.3.12 that the tensor product of complete filtered modules (and the tensor product of plain filtered modules similarly) fulfill all our requirements, including the colimit preservation axiom of §0.9. We may however follow another approach to make these constructions more explicit. We precisely explain, in the next paragraphs, that the complete versions of the free Lie algebras, symmetric and tensor algebras, enveloping algebras, considered in §7.2, are identified with completions of their ordinary counterpart. We examine the definition of a Lie algebra structure first.

7.3.19. *Lie algebras in filtered modules and in complete filtered modules.* We immediately get, from the definition of §7.2.1, that the structure a filtered Lie algebra (for a Lie algebra in filtered modules) consists of a filtered module \mathfrak{g} equipped a Lie bracket $\lambda : \mathfrak{g} \otimes \mathfrak{g} \rightarrow \mathfrak{g}$, which defines a Lie structure (in the ordinary sense) on \mathfrak{g} , and preserves filtration. We explicitly assume $[\mathbf{F}_s \mathfrak{g}, \mathbf{F}_t \mathfrak{g}] \subset \mathbf{F}_{s+t} \mathfrak{g}$, for all $s, t \in \mathbb{N}$, where we use the bracket notation $[x, y] = \lambda(x \otimes y)$. When we deal with Lie algebras in complete filtered modules, we assume that \mathfrak{g} is a complete filtered module $\hat{\mathfrak{g}} = \mathfrak{g}$ and we formally replace the plain tensor product in the definition of the Lie bracket by the completed one. We immediately see that any such Lie bracket on the completion $\mathfrak{g} \hat{\otimes} \mathfrak{g} = (\mathfrak{g} \otimes \mathfrak{g})^\wedge$ arises as the extension of an ordinary filtration preserving Lie bracket on \mathfrak{g} :

$$\begin{array}{ccc}
 \mathfrak{g} \otimes \mathfrak{g} & \xrightarrow{\lambda} & \mathfrak{g} \\
 \searrow & & \nearrow \hat{\lambda} \\
 & \mathfrak{g} \hat{\otimes} \mathfrak{g} &
 \end{array}$$

We obtain, therefore, that a Lie algebra in complete filtered modules is equivalent to a filtered Lie algebra \mathfrak{g} whose underlying filtered module is complete $\hat{\mathfrak{g}} = \mathfrak{g}$.

This observation implies, besides, that we have an embedding of the category of Lie algebras in complete filtered modules into the category of Lie algebras in filtered modules. We see that this embedding is a right adjoint of the functor induced by the completion $(-)^{\wedge} : \mathfrak{g} \mapsto \hat{\mathfrak{g}}$, where we use the preservation of symmetric monoidal structures, asserted in §7.3.12, to get that the completion $\hat{\mathfrak{g}}$ of a Lie algebra in filtered modules \mathfrak{g} inherits a Lie algebra structure.

7.3.20. *Connected filtered Lie algebras and complete Lie algebras.* We say that a filtered Lie algebra is connected when we have $\mathbf{E}_0^0 \mathfrak{g} = \mathfrak{g} / \mathbf{F}_1 \mathfrak{g} = 0$, so that the filtration of our Lie algebra has the form $\mathfrak{g} = \mathbf{F}_1 \mathfrak{g} \supset \dots \supset \mathbf{F}_s \mathfrak{g} \supset \dots$. We use the notation $f\mathcal{L}ie_0$ for the subcategory of connected filtered Lie algebras. In the case of Lie algebras in complete filtered modules, we suppose that the requirement $\mathbf{E}_0^0 \mathfrak{g} = 0$ (equivalently, $\mathfrak{g} = \mathbf{F}_1 \mathfrak{g}$) is satisfied in all applications. Therefore we reserve the expression of complete Lie algebra and we use the notation $\widehat{\mathcal{L}ie}$ (with no further precision) for the subcategory of Lie algebras in complete filtered modules that fulfill this condition $\mathbf{E}_0^0 \mathfrak{g} = 0$.

The mapping $\mathbf{E}^0 : M \mapsto \mathbf{E}^0 M$ also induces a functor on Lie algebra categories since we observed in §7.3.13 that this mapping is a symmetric monoidal functor in the sense of §2.3. The requirement $\mathbf{E}^0 \mathfrak{g} = 0$ amounts to defining the category of connected filtered (respectively, complete) Lie algebras as the counter-image of the category connected weight graded Lie algebras of §7.3.17 under the functor $\mathbf{E}^0 : \mathfrak{g} \mapsto \mathbf{E}^0 \mathfrak{g}$. The connections between our Lie algebra categories are summarized

$\widehat{\mathcal{L}ie} = \widehat{f\mathcal{L}ie}$
 in revised
 versions of
 this work

by the functor diagram:

$$\begin{array}{ccc}
 f\mathcal{L}ie_0 & \xrightleftharpoons{(-)^\wedge} & \widehat{\mathcal{L}ie} \\
 \searrow^{E^0} & & \swarrow_{E^0} \\
 & w\mathcal{L}ie_0 &
 \end{array}$$

where the horizontal arrows are the embedding and completion functors of §7.3.19.

We now aim to revisit the construction of the symmetric algebras, tensor algebras, and enveloping algebras of §7.2 in the setting of complete filtered modules. We then deal with unitary associative algebras and unitary commutative algebras in complete filtered modules. We examine the definition of these structures in a preliminary stage. We also deal, for our purpose, with auxiliary categories of unitary associative algebras and unitary commutative algebras in filtered modules.

7.3.21. *Unitary associative and unitary commutative algebras in complete filtered modules.* We immediately see (as in the Lie algebra case) that a unitary associative (respectively, commutative) algebra in filtered modules is equivalent to a filtered module A equipped with a unit $\eta : \mathbb{k} \rightarrow A$ and product morphisms $\mu : A \otimes A \rightarrow A$, which provide A with a unitary associative (respectively, commutative) structure (in the ordinary sense), and preserve filtrations (this condition is void for the unit since we assume $F_1 \mathbb{k} = 0$). We also readily observe that a unitary associative (respectively, commutative) algebra in complete filtered modules is equivalent to a unitary associative (respectively, commutative) algebra in filtered modules A which is complete as a filtered module $A = \hat{A}$, because we have $\hat{\mathbb{k}} = \mathbb{k}$ and any product in the sense of the symmetric monoidal structure of complete filtered modules $\hat{\mu} : A \hat{\otimes} A \rightarrow A$ arises as an extension of a product in the ordinary sense $\mu : A \otimes A \rightarrow A$.

We say that a unitary associative (respectively, commutative) algebra in filtered modules is connected when we have $E_0^0 A = A/F_1 A = \mathbb{k}$. When we work in the complete setting, we reserve the expression of complete unitary associative (respectively, commutative) algebras for the unitary associative (respectively, commutative) algebras in complete filtered modules which fulfill this connectedness requirement. We adopt the notation $f\mathcal{A}s_1$ (respectively, $f\mathcal{C}om_1$) for the subcategory of connected filtered unitary associative (respectively, commutative) algebras, and the notation $\widehat{\mathcal{A}s}$ (respectively, $\widehat{\mathcal{C}om}$) for the subcategory of complete unitary associative (respectively, commutative) algebras. We use similar conventions for unitary associative (respectively, commutative) algebras in weight graded modules and we have a diagram, similar to the functor diagram of §7.3.20, summarizing the connections between these algebra categories.

The observations of this paragraph imply that the completion functor $(-)^\wedge : A \mapsto \hat{A}$ induces a functor on filtered unitary associative (respectively, commutative) algebras. We readily see that the functor defines a left adjoint of the category embedding $i : \widehat{\mathcal{A}s} \hookrightarrow f\mathcal{A}s_1$ (respectively, $i : \widehat{\mathcal{C}om} \hookrightarrow f\mathcal{C}om_1$).

7.3.22. *The completion of free algebras.* We can apply the general construction of §7.2.4 to get the definition of a tensor (respectively, symmetric) algebra in the category of filtered modules (and in the category of complete filtered modules similarly). We can also use the general construction of §7.2.3 to get the definition of free Lie algebras. In all case, we simply replace the generic direct sums and

↑ fts and ↑ Com in revised versions of this work

tensor products of §7.2 by the coproduct and tensor product of our categories (the complete direct sum $\hat{\oplus}$ and the complete tensor product $\hat{\otimes}$ in the complete filtered module setting).

When we deal with plain filtered modules, we can identify the tensor algebra $\mathbb{T}(M)$ with the standard tensor algebra associated to the module M , which we equip with the filtration $\mathbb{T}(M) = \mathbf{F}_0 \mathbb{T}(M) \supset \cdots \supset \mathbf{F}_s \mathbb{T}(M) \supset \cdots$ such that $\mathbf{F}_s \mathbb{T}(M) = \bigoplus_{r=0}^{\infty} \mathbf{F}_s(M^{\otimes r})$ and $\mathbf{F}_s(M^{\otimes r}) = \sum_{s_1+\cdots+s_r=s} \mathbf{F}_{s_1} M \otimes \cdots \otimes \mathbf{F}_{s_r} M$. We have a similar observation in the symmetric algebra and free Lie algebra case.

When we deal with a complete filtered module $M = \hat{M}$, we use the notation $\hat{\mathbb{T}}(M)$ to refer to the complete tensor algebra associated to M , and $\mathbb{T}(M)$ for the ordinary tensor algebra (formed in the category of filtered modules) which we also use as an auxiliary structure in this context. We adopt an analogous notation $\hat{\mathbb{S}}(M)$ for the complete symmetric algebra associated to M , which we oppose to the ordinary symmetric algebra $\mathbb{S}(M)$. We similarly set $\hat{\mathbb{L}}(M)$ for the complete free Lie algebra associated to M , and $\mathbb{L}(M)$ for the ordinary free Lie algebra in the category of filtered modules.

We actually immediately obtain, by using the adjunction between unitary associative (respectively, commutative) algebras in filtered modules and in complete filtered modules, that the complete tensor (respectively, symmetric) algebra can be realized as the completion of the ordinary tensor (respectively, symmetric) algebra. We more generally have $\hat{\mathbb{T}}(\hat{M}) = \mathbb{T}(M)^\wedge$ for any filtered module $M \in fMod$. We have similarly $\hat{\mathbb{S}}(\hat{M}) = \mathbb{S}(M)^\wedge$ in the case of the symmetric algebra, and $\hat{\mathbb{L}}(\hat{M}) = \mathbb{L}(M)^\wedge$ in the case of the free Lie algebra. We can use this relationship to get an explicit representation of the complete tensor (respectively, symmetric, free Lie) algebra.

Let $R = \mathbb{S}(M)$ (respectively, $R = \mathbb{T}(M)$) denote the symmetric (respectively, tensor) algebra associated with a filtered module M . The definition of the counit $\epsilon : R \rightarrow \mathbb{k}$, coproduct $\Delta : R \rightarrow R \otimes R$, and antipode $\sigma : R \rightarrow R$ in the construction of Proposition 7.2.6 automatically returns filtration preserving morphisms that define the counitary cocommutative coalgebra structure of our algebra $R = \mathbb{S}(M), \mathbb{T}(M)$ in filtered modules. In the complete case, the counit $\hat{\epsilon} : \hat{R} \rightarrow \mathbb{k}$, coproduct $\hat{\Delta} : \hat{R} \rightarrow \hat{R} \hat{\otimes} \hat{R}$ and antipode $\hat{\sigma} : \hat{R} \rightarrow \hat{R}$, obtained by completion from these morphisms, clearly yield the counitary cocommutative coalgebra structure of the complete algebra $\hat{R} = \hat{\mathbb{S}}(M), \hat{\mathbb{T}}(M)$ associated to R .

7.3.23. Connectedness assumptions and complete free algebras. We generally consider the complete tensor algebra of complete filtered modules M such that $\mathbf{E}_0^0 M = 0 \Leftrightarrow M = \mathbf{F}_1 M$. We readily see that $M = \mathbf{F}_1 M \Rightarrow \mathbf{E}_0^0 \hat{\mathbb{T}}(M) = \mathbf{E}_0^0 \mathbb{T}(M) = \mathbb{k}$ so that the complete tensor algebra $\hat{\mathbb{T}}(M)$ associated to a complete filtered modules M which satisfies this connectedness requirement $\mathbf{E}_0^0 M = 0$ forms a complete unitary associative algebra in the sense of §7.3.21. We have similar results in the symmetric algebra and free Lie algebra case.

In the case $\mathbf{E}_0^0 M = 0$, we moreover have

$$\hat{\mathbb{S}}(M) = \prod_{r=0}^{\infty} (M^{\hat{\otimes} r})_{\Sigma_r} \quad \text{and} \quad \hat{\mathbb{T}}(M) = \prod_{r=0}^{\infty} M^{\hat{\otimes} r},$$

essentially because this condition $\mathbf{E}_0^0 M = 0 \Leftrightarrow M = \mathbf{F}_1 M$ implies the inclusion relation $M^{\otimes r} = \mathbf{F}_r(M^{\otimes r}) \subset \mathbf{F}_r \mathbb{T}(M)$ for each $r \in \mathbb{N}$, and similarly in the symmetric algebra case. In other terms, the complete direct sums $\hat{\oplus}$, which we usually have in the expansion of the tensor and symmetric algebra, reduce to an ordinary product

when the module M is connected. We also have

$$\hat{\mathbb{L}}(M) = \prod_{r=0}^{\infty} \hat{\mathbb{L}}_r(M)$$

in the free Lie algebra case, where we take

$$\hat{\mathbb{L}}_r(M) = \mathbb{L}_r(M)^\wedge = (\text{Lie}(r) \otimes M^{\hat{\otimes} r})_{\Sigma_r},$$

the completion of the homogeneous summands of the ordinary free Lie algebra in the expansion of §7.2.3.

7.3.24. *The completed enveloping algebras of Lie algebras, primitive elements and adjunctions.* We can readily extend our analysis of the construction of symmetric and tensor algebras to enveloping algebras.

When we deal with a Lie algebra in filtered modules \mathfrak{g} , we can provide the usual enveloping algebra associated to \mathfrak{g} (as explicitly defined §7.2.9) with a canonical filtration, so that this algebra $\mathbb{U}(\mathfrak{g})$ naturally forms a unitary associative algebra in the category of filtered modules and satisfies the adjunction relation of enveloping algebras (see §7.2.7) in this setting. When the Lie algebra is complete $\hat{\mathfrak{g}} = \mathfrak{g}$, we adopt the notation $\hat{\mathbb{U}}(\mathfrak{g})$ for the enveloping algebra in complete filtered modules associated to \mathfrak{g} , as opposed to the ordinary enveloping algebra in filtered modules $\mathbb{U}(\mathfrak{g})$, which we use as an auxiliary construction in this setting. We can actually readily identify the complete enveloping algebra $\hat{\mathbb{U}}(\mathfrak{g})$ with the completion of the ordinary enveloping algebra $\mathbb{U}(\mathfrak{g})$. We more generally have $\hat{\mathbb{U}}(\hat{\mathfrak{g}}) = \mathbb{U}(\mathfrak{g})^\wedge$ for any Lie algebra in filtered modules \mathfrak{g} .

We moreover easily see that the counit $\hat{\epsilon} : \hat{\mathbb{U}}(\mathfrak{g}) \rightarrow \mathbb{k}$, coproduct $\hat{\Delta} : \hat{\mathbb{U}}(\mathfrak{g}) \rightarrow \hat{\mathbb{U}}(\mathfrak{g}) \hat{\otimes} \hat{\mathbb{U}}(\mathfrak{g})$ and antipode $\hat{\sigma} : \hat{\mathbb{U}}(\mathfrak{g}) \rightarrow \hat{\mathbb{U}}(\mathfrak{g})$, defining the counitary cocommutative coalgebra structure of the enveloping algebra in the complete case, are identified with the morphisms induced by the counit, coproduct and antipode of the ordinary enveloping algebra $\mathbb{U}(\mathfrak{g})$ on the completion. We have besides $\mathbf{E}_0^0 \hat{\mathbb{U}}(\mathfrak{g}) = \mathbb{k}$ as soon as our Lie algebra satisfies $\mathbf{E}^0 \mathfrak{g} = 0 \Leftrightarrow \mathfrak{g} = \mathbf{F}_1 \mathfrak{g}$. Accordingly, we obtain under our conventions that the complete enveloping algebra functor induces a functor from the category of complete Lie algebras $\widehat{\mathcal{L}ie}$ towards the category of complete Hopf algebras $\widehat{\mathcal{H}opfGrp}$:

$$\hat{\mathbb{U}} : \widehat{\mathcal{L}ie} \rightarrow \widehat{\mathcal{H}opfGrp}.$$

In the converse direction, the image of a Hopf algebra H under the primitive element functor $\mathbb{P} : H \mapsto \mathbb{P}(H)$ is defined, in the complete case, as the submodule

$$\mathbb{P}(H) = \{x \in H \mid \epsilon(x) = 0, \Delta(x) = x \hat{\otimes} 1 + 1 \hat{\otimes} x\},$$

which we equip with the induced filtration of §7.3.1(b). Recall that this object is complete and is identified with the appropriate kernel in the category of complete filtered modules (see §7.3.4). In the case of a complete Hopf algebra, we moreover have $\mathbf{E}_0^0 H = \mathbb{k} \Rightarrow \mathbf{E}_0^0 \mathbb{P}(H) = 0$ so that the mapping $\mathbb{P} : H \mapsto \mathbb{P}(H)$ yields a functor from the category of complete Hopf algebras $\widehat{\mathcal{H}opfGrp}$ towards the category of complete Lie algebras $\widehat{\mathcal{L}ie}$:

$$\mathbb{P} : \widehat{\mathcal{H}opfGrp} \rightarrow \widehat{\mathcal{L}ie}.$$

The adjunction of Proposition 7.2.13 between the enveloping algebra and primitive element functors also holds in the complete context.

The results of Proposition 7.2.14, also holds in the category of complete filtered modules since this category fits the assumptions of §7.2. Thus, we have $\mathbb{P}\hat{\mathbb{T}}(M) = \hat{\mathbb{L}}(M)$.

In the rest of this section, we check the analogue of the structure theorems of §7.2 for complete Hopf algebras. To start with, we observe that:

THEOREM 7.3.25. *The symmetrization morphism of Theorem 7.2.16 (the Structure Theorem of Hopf algebras) gives, in the complete setting, an iso of counitary cocommutative coalgebras*

$$e : \hat{\mathbb{S}}\mathbb{P}(H) \xrightarrow{\cong} H$$

for any complete Hopf algebra $H \in \widehat{\mathcal{H}opfGrp}$ (satisfying our requirement $H/\mathbb{F}_1 H = \mathbb{k}$).

EXPLANATION AND PROOF. In §7.2, we use a local conilpotence condition to establish this statement in a general context. Recall that this assumption is essentially used to have a limit decomposition of the endomorphism algebra $\mathbf{End}(H)$ and give a sense to formal sums in this object.

In the case of a complete Hopf algebra H , we more naturally use the relation $H = \lim_s H/\mathbb{F}_s H$ to get a limit decomposition at the level of hom-objects $\mathbf{Hom}(-, H) = \lim_s \mathbf{Hom}(-, H/\mathbb{F}_s H)$, and we can similarly take the decomposition $\mathbf{Hom}(-, H \hat{\otimes} H) = \lim_s \mathbf{Hom}(-, H \otimes H/\mathbb{F}_s(H \otimes H))$ when we have to deal with hom-objects towards a tensor product. We easily check that the proof of Theorem 7.2.16 works same when we take this limit decomposition instead of the one considered in §7.2. We precisely use the connectedness condition $H/\mathbb{F}_1 H = \mathbb{k}$ to give a sense to our formal sums $\sum_n \lambda_n \pi^n$. We therefore get a version of the result of Theorem 7.2.16 for complete Hopf algebras, as claimed in the present theorem. (Just note that we have to take the complete direct sums of §7.3.4(a) instead of the ordinary direct sums when we work in the category of complete filtered modules.) \square

This structure theorem is completed by the following analogues of the Poincaré-Birkhoff-Witt and Milnor-Moore theorems:

THEOREM 7.3.26.

- (a) *The symmetrization morphism of Theorem 7.2.17 (the Poincaré-Birkhoff-Witt Theorem) gives, in the complete setting, an iso of counitary cocommutative coalgebras*

$$e : \hat{\mathbb{S}}(\mathfrak{g}) \xrightarrow{\cong} \hat{\mathbb{U}}(\mathfrak{g})$$

for any complete Lie algebra $\mathfrak{g} \in \widehat{\mathcal{L}ie}$.

- (b) *The result of Theorem 7.2.19 (the Milnor-Moore theorem) implies, in the complete setting, that the complete enveloping algebra $\hat{\mathbb{U}} : \mathfrak{g} \mapsto \hat{\mathbb{U}}(\mathfrak{g})$ and primitive element functors $\mathbb{P} : H \mapsto \mathbb{P}(H)$, define adjoint equivalences of categories*

$$\hat{\mathbb{U}} : \widehat{\mathcal{L}ie} \rightleftarrows \widehat{\mathcal{H}opfGrp} : \mathbb{P}$$

between the category of complete Lie algebras $\widehat{\mathcal{L}ie}$ and the category of complete Hopf algebras $\widehat{\mathcal{H}opfGrp}$.

PROOF. The claim of assertion (a) follows from the statement of Theorem 7.2.17 (just recall that this result holds for any Lie algebra in a general \mathbb{Q} -additive symmetric monoidal category setting which includes the example of complete filtered

module as a particular case). The argument line of Theorem 7.2.19 works and yields a proof of assertion (b) as soon as we have the result of the Structure Theorem and the result of the Poincaré-Birkhoff-Witt Theorem. In the case of complete filtered modules, these results are provided by the statements of Theorem 7.3.25 and Theorem 7.3.26(a). \square

For the sake of completeness, we record the following relationship between the complete and weight graded versions of our functors:

PROPOSITION 7.3.27.

- (a) For any complete filtered module $M \in \widehat{\mathcal{M}od}$, we have the relation $\mathbf{E}^0 \hat{\mathcal{S}}(M) = \mathcal{S}(\mathbf{E}^0 M)$, $\mathbf{E}^0 \hat{\mathcal{T}}(M) = \mathcal{T}(\mathbf{E}^0 M)$, and $\mathbf{E}^0 \hat{\mathcal{L}}(M) = \mathcal{L}(\mathbf{E}^0 M)$.
- (b) For a complete Hopf algebra $H \in \widehat{\mathcal{H}opfGrp}$, we have $\mathbf{E}^0 \mathcal{P}(H) = \mathcal{P}(\mathbf{E}^0 H)$.
- (c) For a complete Lie algebra $\mathfrak{g} \in \widehat{\mathcal{L}ie}$, we have $\mathbf{E}^0 \hat{\mathcal{U}}(\mathfrak{g}) = \mathcal{U}(\mathbf{E}^0 \mathfrak{g})$.

PROOF. In fact, we prove that we have the relations $\mathbf{E}^0 \mathcal{S}(M) = \mathcal{S}(\mathbf{E}^0 M)$ and $\mathbf{E}^0 \mathcal{T}(M) = \mathcal{T}(\mathbf{E}^0 M)$ at the level of plain filtered modules, and we use the general identity $\mathbf{E}^0(-)^\wedge = \mathbf{E}^0(-)$ to get the complete case of these identities, as asserted in our proposition.

The identity $\mathbf{E}^0 \mathcal{T}(M) = \mathcal{T}(\mathbf{E}^0 M)$ follows from the preservation of the tensor product (see §7.3.13) and direct sums (see Proposition 7.3.8) by the filtration subquotient functor $\mathbf{E}^0 : f\mathcal{M}od \rightarrow w\mathcal{M}od$. In any \mathbb{Q} -additive symmetric monoidal category, the quotient map $\mathcal{T}_r(M) \rightarrow \mathcal{S}_r(M)$ from the tensor product $\mathcal{T}_r(M) = M^{\otimes r}$ to the symmetric tensor product $\mathcal{S}_r(M) = (M^{\otimes r})_{\Sigma_r}$ admits a natural section, for every $r \in \mathbb{N}$, which is defined by the symmetrization map $e(x_1 \cdots x_r) = \sum_{\sigma \in \Sigma_r} x_{\sigma(1)} \otimes \cdots \otimes x_{\sigma(r)}$. The functor $\mathbf{E}^0 : M \mapsto \mathbf{E}^0 M$ preserves this retraction diagram (because \mathbf{E}^0 preserves the symmetry isomorphism of our symmetric monoidal structure). Therefore, we also have $\mathbf{E}^0 \mathcal{S}_r(M) = \mathcal{S}_r(\mathbf{E}^0 M)$ for the symmetric tensor functor $\mathcal{S}_r(-)$, and we conclude that $\mathbf{E}^0 \mathcal{S}(M) = \mathcal{S}(\mathbf{E}^0 M)$. The case of the free Lie algebra follows from the same argument line as the symmetric algebra by using the observation, established in Proposition 7.2.8, that the free Lie algebra forms a natural retract of the tensor algebra.

The second and third assertions of the proposition readily follow from the identity $\mathbf{E}^0 \hat{\mathcal{S}}(M) = \mathcal{S}(\mathbf{E}^0 M)$ and the parallel statements of the structure theorems of Hopf algebras established in this section, in the weight graded (Theorem 7.3.18) and complete settings (Theorem 7.3.25-7.3.26). \square

The Malcev Completion for Groups

In this chapter, we give an account of the applications of Hopf algebras for the definition of a category of Malcev complete groups, where we have power operations g^a with exponents a in any given ground field \mathbb{k} . We also examine the specific case $\mathbb{k} = \mathbb{Q}$, where the Malcev completion construction is identified with a generalization to pro-nilpotent groups of the rationalization functor on abelian groups.

The main idea of our approach is to consider a complete version of the group algebras of §7.1.13, a complete version of the group-like element functor of §7.1.14, and to check that these functors form an adjoint pair:

$$\mathbb{k}[-]^\wedge : \mathcal{G}rp \rightleftarrows \widehat{\mathcal{H}opf\mathcal{G}rp} : \mathbb{G},$$

like the ordinary group algebra and group-like element functors. We precisely define our category of Malcev complete groups $\widehat{\mathcal{G}rp}$ as the image of the category of complete Hopf algebras under the group-like element functor $\mathbb{G} : \widehat{\mathcal{H}opf\mathcal{G}rp} \rightarrow \mathcal{G}rp$. We have an obvious Malcev complete group \hat{G} , assigned to any group G , defined by the formula

$$\hat{G} = \mathbb{G}\mathbb{k}[G]^\wedge,$$

where we take the composite of the group-like element and complete Hopf algebra functors of our adjunction relation. This map $(-)^{\wedge} : G \mapsto \hat{G}$ is our Malcev completion functor with coefficients in the field \mathbb{k} .

The structure theorems of complete Hopf algebras imply that we have an equivalence between the Malcev groups $\hat{G} = \mathbb{G}(H)$ and the complete Lie algebras $\mathfrak{g} = \mathbb{P}(H)$, and we use this correspondence to get insights into the structure of Malcev complete groups. To be specific, the definition of the logarithm and exponential functions, in terms of power series, makes sense in any complete Hopf algebra. We will check that these maps induce inverse bijections between primitive and group-like elements, and as a consequence, that every element in a Malcev complete group \hat{G} is represented by an exponential $g = e^x$ such that x belongs to the Lie algebra \mathfrak{g} associated to \hat{G} . The definition of general power operations g^a in \hat{G} , where $a \in \mathbb{k}$, follows from this exponential representation. Indeed, for an element $g = e^x$, we can simply set $g^a = e^{ax}$.

We devote the first section of the chapter §8.1 to the definition of the complete group-like element and complete group algebra functors. We also define the exponential correspondence, between primitive and group like elements, at this point. We devote the second section §8.2 to the definition and the study of the category of Malcev complete groups.

In a third section §8.3, we study the Malcev completion of free groups and of groups defined by generators and relations. We use the correspondence between

Hopf algebras and Lie algebras to give another explicit description, in terms of commutator expansions, of elements in the Malcev completion of such groups.

To complete our account, we give, in the fourth section of the chapter §8.4, a survey of the rational case of the Malcev completion process. In this setting, we actually have an equivalence between our category of Malcev complete groups and the category of uniquely divisible pro-nilpotent groups. Furthermore, the group \hat{G} , returned by our Malcev completion functor, represents, according to [145, Corollary A.3.7-A.3.8], a universal uniquely divisible pro-nilpotent group associated to G . This statement implies that our Malcev completion functor, of which we actually borrow the definition from [145, Appendix A], returns the same result as the classical Malcev completion of groups [124].

We assume throughout this chapter that the ground ring \mathbb{k} is a field of characteristic 0. We consider the category of modules associated to this field $\text{Mod} = \text{Mod}_{\mathbb{k}}$, and the associated category of complete filtered modules $\widehat{\text{Mod}} = \widehat{\text{Mod}}_{\mathbb{k}}$ (see §7.3).

8.1. The adjunction between groups and complete Hopf algebras

The main purpose of this section is to define the complete version of the group algebra and group-like element functors of §7.1. The idea is to observe that any ordinary algebra H inherits a canonical filtration, in the sense of §7.3.1, and to perform the completion process of §7.3.3 with respect to this filtration on the ordinary group algebra $\mathbb{k}[-]$ in order to get our complete group algebra $\mathbb{k}[-]^\wedge$.

We explain the general definition of this canonical filtration first.

8.1.1. *The canonical completion of a Hopf algebra.* Let H be any Hopf algebra in the category of \mathbb{k} -modules. Let $\mathbb{l}(H) = \ker(\epsilon : H \rightarrow \mathbb{k})$ be the augmentation ideal associated to H . Recall that H admits a splitting $H = \mathbb{k}1 \oplus \mathbb{l}(H)$, where $1 \in H$ refers to the unit element of the Hopf algebra. Let $\mathbb{l}^n(H)$, for any $n \in \mathbb{N}$, denote the n th power of the augmentation ideal $\mathbb{l}(H)$ in the unitary algebra H . These ideals form a nested sequence

$$(a) \quad H = \mathbb{l}^0(H) \supset \mathbb{l}^1(H) \supset \dots \supset \mathbb{l}^n(H) \supset \dots$$

defining a canonical filtration of our Hopf algebra H .

The counit $\epsilon : H \rightarrow \mathbb{k}$ satisfies $\epsilon(\mathbb{l}(H)) = 0$ by definition, and hence, defines a filtration preserving morphism towards the ground field \mathbb{k} , which we equip with the filtration such that $F_0 \mathbb{k} = \mathbb{k}$ and $F_s \mathbb{k} = 0$ for $s > 0$ (see §7.3.9). The counit identities $\epsilon \otimes id \cdot \Delta(u) = id \otimes \epsilon \cdot \Delta(u) = u$ imply that the coproduct of an element $u \in \mathbb{l}(H)$, has the form:

$$(b) \quad \Delta(u) = \underbrace{u \otimes 1 + 1 \otimes u}_{\in \mathbb{l}(H) \otimes 1 + 1 \otimes \mathbb{l}(H)} + \underbrace{\sum'_{(u)} u_{(1)} \otimes u_{(2)}}_{\in \mathbb{l}(H) \otimes \mathbb{l}(H)}.$$

In what follows, we generally use the expression $\sum'_{(u)} u_{(1)} \otimes u_{(2)}$ to denote the terms of the coproduct $\Delta(u) = \sum_{(u)} u_{(1)} \otimes u_{(2)}$ lying in the summand $\mathbb{l}(H) \otimes \mathbb{l}(H)$. From this expansion, we deduce that $u \in \mathbb{l}(H) \Rightarrow \Delta(u) \in \mathbb{l}^1(H) \otimes \mathbb{l}^0(H) + \mathbb{l}^0(H) \otimes \mathbb{l}^1(H)$. In general, for an n -fold product $u = u_1 \cdot \dots \cdot u_n$, we have:

$$u = u_1 \cdot \dots \cdot u_n \in \mathbb{l}^n(H) \Rightarrow \Delta(u) = \Delta(u_1) \cdot \dots \cdot \Delta(u_n) \in \sum_{p+q=n} \mathbb{l}^p(H) \otimes \mathbb{l}^q(H),$$

and this relation proves that the coproduct of our Hopf algebra $\Delta : H \rightarrow H \otimes H$ is a filtration preserving morphism.

Recall that the preservation of filtration is a void condition for the unit morphism (see §7.3.21). The product $\mu : H \otimes H \rightarrow H$ is obviously a filtration preserving morphism too since we have $\mathbb{I}^p(H) \cdot \mathbb{I}^q(H) = \mathbb{I}^{p+q}(H)$ by definition of the powers of an ideal. For the antipode, we have $u \in \mathbb{I}(H) \Rightarrow \sigma(u) \in \mathbb{I}(H)$ and

$$u = u_1 \cdot \dots \cdot u_n \in \mathbb{I}^n(H) \Rightarrow \sigma(u) = \sigma(u_n) \cdot \dots \cdot \sigma(u_1) \in \mathbb{I}^n(H)$$

by Proposition 7.1.10 so that the antipode $\sigma : H \rightarrow H$ preserves our filtration as well.

We also trivially have $\mathbb{I}(H) = \ker(\epsilon : H \rightarrow \mathbb{k}) \Leftrightarrow H/\mathbb{I}(H) = \mathbb{k}1$. We conclude from these observations that our filtration by the powers of the augmentation ideal (a) provides H with the structure of a connected filtered Hopf algebra in the sense of §7.3.15. By observations of §§7.3.14-7.3.15, we can take the completion of this filtered object (a) to get a complete Hopf algebra

$$(c) \quad \hat{H} = \lim_n H/\mathbb{I}^n(H)$$

canonically associated to H .

8.1.2. *The complete group algebra and group-like element functors.* We associate a complete group algebra $\mathbb{k}[G]^\wedge$ to any group G by taking the completion §8.1.1(c) of the ordinary group algebra $H = \mathbb{k}[G]$ of §7.1.13. We explicitly set

$$\mathbb{k}[G]^\wedge = \lim_n \mathbb{k}[G]/\mathbb{I}^n \mathbb{k}[G]$$

to get a functor $\mathbb{k}[-]^\wedge : \mathcal{G}rp \rightarrow \widehat{\mathcal{H}opf\mathcal{G}rp}$ from the category of groups $\mathcal{G}rp$ towards the category of complete Hopf algebras $\widehat{\mathcal{H}opf\mathcal{G}rp}$.

We use a complete analogue of the group-like element functor of §7.1.14 to define a functor in the converse direction. The set of group-like elements in a counitary cocommutative coalgebra in the category of complete filtered modules is explicitly defined by:

$$\mathbb{G}(C) = \{c \in C \mid \epsilon(c) = 1, \Delta(c) = c \hat{\otimes} c\},$$

where the tensor $c \hat{\otimes} c \in C \hat{\otimes} C$, associated to any $c \in C$, represents the image of the ordinary tensor product $c \otimes c \in C \otimes C$ under the completion morphism $C \otimes C \rightarrow C \hat{\otimes} C$. In the case of a complete Hopf algebra $C = H$, we obtain (as in Proposition 7.1.15) that:

$$\begin{aligned} 1 &\in \mathbb{G}(H), \\ g, h \in \mathbb{G}(H) &\Rightarrow g \cdot h \in \mathbb{G}(H), \\ g \in \mathbb{G}(H) &\Rightarrow \sigma(g) \in \mathbb{G}(H) \quad \text{and} \quad g \cdot \sigma(g) = \sigma(g) \cdot g = 1. \end{aligned}$$

Hence, the set of group-like elements of a complete Hopf algebra $\mathbb{G}(H)$ forms, like the set of group-like elements of an ordinary Hopf algebra, a group naturally associated H .

Proposition 7.1.16 has the following analogue in the context of complete Hopf algebras:

PROPOSITION 8.1.3. *The complete group algebra $\mathbb{k}[-]^\wedge : G \mapsto \mathbb{k}[G]^\wedge$ and group-like functors $\mathbb{G} : H \rightarrow \mathbb{G}(H)$ obtained by the construction of §8.1.2 define a pair*

of adjoint functors $\mathbb{k}[-]^\wedge : \mathcal{G}rp \rightleftarrows \widehat{\mathcal{H}opf\mathcal{G}rp} : \mathbb{G}$ between the category of groups $\mathcal{G}rp$ and the category of complete Hopf algebras $\widehat{\mathcal{H}opf\mathcal{G}rp}$.

PROOF. Let $G \in \mathcal{G}rp$. Let $H \in \widehat{\mathcal{H}opf\mathcal{G}rp}$. In §7.3.21, we observe that the completion functor defines a left adjoint of the obvious embedding from the category of unitary associative algebras in complete filtered modules towards the category unitary associative algebras in filtered modules. Consequently, we have an equivalence between the morphisms of complete unitary associative algebras $\hat{\phi} : \mathbb{k}[G]^\wedge \rightarrow H$ and the morphisms of ordinary unitary associative algebras $\phi : \mathbb{k}[G] \rightarrow H$ such that $\phi(\mathbb{l}^n \mathbb{k}[G]) \subset \mathbf{F}_n H$. This morphism is uniquely determined by the images $\phi(g) \in H$ of the group elements $g \in G$ and the preservation of the unit and product reduces to the usual equations $\phi(1) = 1$ and $\phi(gh) = \phi(g) \cdot \phi(h)$ in H . The completion adjunction also implies that the preservation of augmentation and coproducts is equivalent to the verification of the identities $\epsilon\phi(g) = 1$ and $\Delta\phi(g) = \phi(g) \hat{\otimes} \phi(g)$ in H , and hence to the belonging relation $\phi(g) \in \mathbb{G}(H)$. To complete these verifications, simply observe that for a complete Hopf algebra, such that $\mathbf{E}_0^0 H = \mathbb{k} \Leftrightarrow \mathbb{l}(H) = \mathbf{F}_1 H$, the relation $\epsilon\phi(g) = 1 \Rightarrow \phi(g - 1) \in \mathbf{F}_1 H$ automatically implies $\phi(\mathbb{l}^n \mathbb{k}[G]) \subset (\mathbf{F}_1 H)^n \subset \mathbf{F}_n H$, and hence, that our morphism is filtration preserving. \square

8.1.4. *Logarithms and exponentials.* Recall that we assume $\mathbf{E}_0^0 H = H/\mathbf{F}_1 H = \mathbb{k}$ for any complete Hopf algebra H . In the proof of Proposition 8.1.3, we have already observed that this condition implies $\mathbf{F}_1 H = \mathbb{l}(H)$ and $\mathbb{l}(H)^n = (\mathbf{F}_1 H)^n \subset \mathbf{F}_n H$ for any $n \in \mathbb{N}$. We can use this observation to give a sense to logarithm

$$\log(\underbrace{1+h}_{=g}) = \sum_{n=1}^{\infty} (-1)^{n-1} \cdot \frac{h^n}{n}$$

and exponential maps

$$\exp(x) = e^x = \sum_{n=0}^{\infty} \frac{x^n}{n!}$$

when we have $h \in \mathbb{l}(H) \Leftrightarrow \epsilon(g) = \epsilon(1+h) = 1$ and $x \in \mathbb{l}(H) \Leftrightarrow \epsilon(x) = 0$. We formally define the logarithm $\log(1+h) \in H = \lim_r H/\mathbf{F}_{r+1} H$ by the sequence of truncated power series $\log_r(1+h) = \sum_{n=1}^r (-1)^{n-1} \cdot (1/n) \cdot h^n$, by using $h \in \mathbb{l}(H) \Rightarrow h^{r+1} \in \mathbf{F}_{r+1} H \Rightarrow \log_{r+1}(1+h) \equiv \log_r(1+h) \pmod{\mathbf{F}_{r+1} H}$, and we use a similar construction in the case of the exponential $\exp(x)$.

We have the following general observation:

PROPOSITION 8.1.5. *In a complete Hopf algebra H , we have*

$$g \in \mathbb{G}(H) \Rightarrow \log(g) \in \mathbb{P}(H) \quad \text{and} \quad x \in \mathbb{P}(H) \Rightarrow \exp(x) \in \mathbb{G}(H),$$

so that the logarithm $\log : g \mapsto \log(g)$ and exponential maps $\exp : x \mapsto \exp(x)$ define inverse bijections between the sets of primitive and group-like elements in H .

PROOF. The identity $\epsilon(\log(g)) = 0$ is obvious, for any $g \in 1 + \mathbb{l}(H)$, and similarly as regards the identity $\epsilon(\exp(x)) = 1$.

The definition of the coproduct as an algebra morphism $\Delta : H \rightarrow H \hat{\otimes} H$ implies $\Delta(\log(g)) = \log(\Delta(g))$, where in the right hand side of this equation, we consider the logarithm of the element $\Delta(g)$ in the tensor product of Hopf algebras

$H \hat{\otimes} H$. For a group-like element, we have $\Delta(\log(g)) = \log(g \hat{\otimes} g)$, and according to the standard addition formula for logarithms, which we apply to the commuting elements $(g \hat{\otimes} 1) \cdot (1 \hat{\otimes} g) = (1 \hat{\otimes} g) \cdot (g \hat{\otimes} 1) = g \hat{\otimes} g$, we obtain:

$$\begin{aligned} \Delta(\log(g)) &= \log(g \hat{\otimes} g) = \log((g \hat{\otimes} 1) \cdot (1 \hat{\otimes} g)) \\ &= \log(g \hat{\otimes} 1) + \log(1 \hat{\otimes} g) = \log(g) \hat{\otimes} 1 + 1 \hat{\otimes} \log(g). \end{aligned}$$

Hence, we have $g \in \mathbb{G}(H) \Rightarrow \log(g) \in \mathbb{P}(H)$ as stated in the proposition.

In the case of the exponential of a primitive element $x \in \mathbb{P}(H)$, we argue similarly to get:

$$\begin{aligned} \Delta(\exp(x)) &= \exp(x \hat{\otimes} 1 + 1 \hat{\otimes} x) = \exp(x \hat{\otimes} 1) \cdot \exp(1 \hat{\otimes} x) \\ &= (\exp(x) \hat{\otimes} 1) \cdot (1 \hat{\otimes} \exp(x)) = \exp(x) \hat{\otimes} \exp(x). \end{aligned}$$

Thus, we have $x \in \mathbb{P}(H) \Rightarrow \exp(x) \in \mathbb{G}(H)$.

The conclusion of the proposition follows from the fact that the logarithm and the exponential are inverse to each other as power series. \square

We have the following result:

PROPOSITION 8.1.6. *The functor $\mathbb{G} : \widehat{\mathcal{H}opfGrp} \rightarrow Grp$ induces an injective map on morphism sets*

$$\text{Mor}_{\widehat{\mathcal{H}opfGrp}}(A, B) \hookrightarrow \text{Mor}_{Grp}(\mathbb{G}(A), \mathbb{G}(B)),$$

for all $A, B \in \widehat{\mathcal{H}opfGrp}$, and hence, is faithful.

This mapping is also bijective when we take $\mathbb{k} = \mathbb{Q}$ as coefficient ring. We establish this result in §8.4.

PROOF. The group morphism $\mathbb{G}(f) : \mathbb{G}(A) \rightarrow \mathbb{G}(B)$ associated to a morphism of complete Hopf algebras $f : A \rightarrow B$ fits in a commutative diagram

$$\begin{array}{ccc} \mathbb{P}(A) & \xrightarrow{\mathbb{P}(f)} & \mathbb{P}(B), \\ \downarrow & & \downarrow \\ \mathbb{G}(A) & \xrightarrow{\mathbb{G}(f)} & \mathbb{G}(B) \end{array} \quad \begin{array}{l} \text{18} \\ \text{16 17} \end{array}$$

where we consider the exponential correspondence of Proposition 8.1.5. Hence, if we have $\mathbb{G}(f) = \mathbb{G}(g)$ for morphisms of complete Hopf algebras $f, g : A \rightarrow B$, then we also have $\mathbb{P}(f) = \mathbb{P}(g)$ and Theorem 7.3.26(b) (the Milnor-Moore theorem) implies that we have $f = g$ as soon as this relation holds. \square

Recall that any category of Hopf algebras, including the example of complete Hopf algebras, inherits a symmetric monoidal structure from the ground category (see §7.2.22). The category of groups is also equipped with a symmetric monoidal structure with the cartesian product as tensor operation. To complete this section, we observe that:

PROPOSITION 8.1.7. *The functors $\mathbb{k}[-]^\wedge : Grp \rightarrow \widehat{\mathcal{H}opfGrp}$ and $\mathbb{G} : \widehat{\mathcal{H}opfGrp} \rightarrow Grp$ are symmetric monoidal, as well as the adjunction relation between them.*

PROOF. For the trivial group, we immediately obtain $\mathbb{k}[pt] = \mathbb{k}$. For a cartesian product $G \times H$, we have a Hopf algebra identity $\mathbb{k}[G \times H] = \mathbb{k}[G] \otimes \mathbb{k}[H]$, and we can also readily check that the filtration by the powers of the augmentation ideal of the group algebra $\mathbb{k}[G \times H]$ agrees with the filtration of the tensor product $\mathbb{k}[G] \otimes \mathbb{k}[H]$. We explicitly have $\mathbb{I}^n \mathbb{k}[G \times H] = \sum_{p+q=n} \mathbb{I}^p \mathbb{k}[G] \otimes \mathbb{I}^q \mathbb{k}[H]$ for all n . We immediately deduce from this relation that we have the identity $\mathbb{k}[G \times H]^\wedge = (\mathbb{k}[G] \otimes \mathbb{k}[H])^\wedge = \mathbb{k}[G]^\wedge \hat{\otimes} \mathbb{k}[H]^\wedge$ at the level of our completed group algebras. We easily check that the isomorphisms which give these relations satisfy the coherence constraints of §2.3.1.

We can actually identify the tensor product of §7.2.22 with a cartesian product bifunctor in the category of Hopf algebras, and our comparison isomorphisms, making the complete group algebra functor into a symmetric monoidal functor are identified with canonical morphisms attached to the cartesian structure of Hopf algebras. We can therefore readily retrieve that these comparison morphisms satisfy the coherence constraints of §2.3.1. We also deduce from the identity between the tensor structure and the cartesian structure of the category of Hopf algebras that the group-like element functor is symmetric monoidal, since this functor preserves all limits by adjunction.

We easily check that the unit and augmentation of our adjunction commute with the isos making our functors symmetric monoidal. We therefore conclude that our functors define a symmetric monoidal adjunction. \square

We will establish a groupoid version of the result of this proposition in §9.3.

8.2. The category of Malcev complete groups

We define the category of Malcev complete groups as the image of the category of complete Hopf algebras under the functor $\mathbb{G} : \widehat{\mathcal{H}opf\mathcal{G}rp} \rightarrow \mathcal{G}rp$. We adopt the notation $\widehat{\mathcal{G}rp}$ for this category:

$$\widehat{\mathcal{G}rp} = \mathbb{G}(\widehat{\mathcal{H}opf\mathcal{G}rp}).$$

We also say that a group G is Malcev complete when we have $G = \mathbb{G}(H)$, for some $H \in \widehat{\mathcal{H}opf\mathcal{G}rp}$, so that $G \in \widehat{\mathcal{G}rp}$.

We define the Malcev completion of a group by the formula $\hat{G} = \mathbb{G}[\mathbb{k}[G]^\wedge]$, where we consider the complete group algebra and group-like element functors of §8.1.2. This group is automatically Malcev complete in our sense.

Proposition 8.1.6 implies that the group-like element functor \mathbb{G} induces an equivalence of categories between the category of complete Hopf algebras and the category of Malcev complete groups. Besides:

PROPOSITION 8.2.1. *Any group morphism $\phi : G \rightarrow H$ where $H = \mathbb{G}(A)$ is Malcev complete admits a unique factorization*

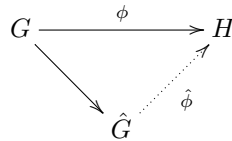

such that $\hat{\phi}$ belongs to the category of Malcev complete groups.

$\widehat{\mathcal{G}rp} = \mathbb{G}\widehat{\mathcal{G}rp}$
 in subsequent versions of his work

PROOF. This proposition is a tautological consequence of the adjunction relation between the complete group algebra and the group like element functors, and the observation that the group-like element functor is injective on morphisms. \square

Most of this section is devoted to the study of natural structures attached to Malcev complete groups $G = \mathbb{G}(H)$ in terms of the exponential correspondence of §§8.1.4-8.1.5. We first define a general notion of group filtration giving a suitable background for this study of the structure of Malcev complete groups.

8.2.2. *Filtrations on groups.* We use the notation (a, b) for the commutator $(a, b) = a^{-1}b^{-1}ab$ in a group G . When we have subgroups $A, B \subset G$, we also use the notation (A, B) for the subgroup of G generated by the commutators $(a, b) \in G$ such that $a \in A$ and $b \in B$. We consider groups G equipped with a filtration

$$(a) \quad G = \mathbf{F}_1 G \supset \cdots \supset \mathbf{F}_n G \supset \cdots$$

by subgroups $\mathbf{F}_n G \subset G$ such that

$$(b) \quad (\mathbf{F}_p G, \mathbf{F}_q G) \subset \mathbf{F}_{p+q} G \quad \text{for all } p, q \in \mathbb{N}.$$

The lower series filtration of the group, inductively defined by

$$\Gamma_1 G = G \quad \text{and} \quad \Gamma_n G = (G, \Gamma_{n-1}(G)) \quad \text{for } n > 1,$$

gives a universal example of a filtration which meets this requirement. In fact, our condition (b) implies that any filtration (a) satisfies $\mathbf{F}_n G \subset \Gamma_n G$ for $n > 0$.

8.2.3. *The weight graded Lie algebra associated to a group.* Suppose we have a group G equipped with a filtration of the form considered in the previous paragraph §8.2.2(a) and satisfying the commutator condition §8.2.2(b). This condition (b) implies, in the case $p = 1$, that the filtration §8.2.2(a) consists of a nested sequence of normal subgroups so that each quotient $\mathbf{F}_n G / \mathbf{F}_{n+1} G$ is abelian. We use additive notation for the abelian group operation associated with these quotients $\mathbf{F}_n G / \mathbf{F}_{n+1} G$. We explicitly set $\bar{u} + \bar{v} = \overline{u \cdot v}$, for any pair $u, v \in \mathbf{F}_n G$, where \bar{g} refers to the class of any element $g \in \mathbf{F}_n G$ in $\mathbf{F}_n G / \mathbf{F}_{n+1} G$. We also adopt the notation $\mathbf{E}^0 G$ for the connected weight graded \mathbb{Z} -module such that:

$$\mathbf{E}^0 G = \bigoplus_{n=1}^{\infty} \underbrace{\mathbf{F}_n G / \mathbf{F}_{n+1} G}_{=\mathbf{E}_n^0 G},$$

where we consider the obvious extension, in the context of modules over a ring, of the notion of weight graded module of §7.3.5.

The requirement $(\mathbf{F}_p G, \mathbf{F}_q G) \subset \mathbf{F}_{p+q} G$ of §8.2.2(b) implies that we can associate a well-defined element $[\bar{u}, \bar{v}] = \overline{(u, v)} \in \mathbf{F}_{m+n} G / \mathbf{F}_{m+n+1} G$ to any pair $\bar{u} \in \mathbf{F}_m G / \mathbf{F}_{m+1} G$ and $\bar{v} \in \mathbf{F}_n G / \mathbf{F}_{n+1} G$ in these quotients. The Philip Hall identities

$$\begin{aligned} (a, b) \cdot (b, a) &= 1, \\ (a, b \cdot c) &= (a, c) \cdot (a, b) \cdot ((a, b), c), \\ ((a, b), c^a) \cdot ((c, a), b^c) \cdot ((b, c), a^b) &= 1, \end{aligned}$$

where $(-, -)$ is our commutator operation and we set $g^h = h^{-1}gh$ for any $g, h \in G$ (see [83, 108]), imply that the mapping $[\bar{x}, \bar{y}] = \overline{(x, y)}$ induces a biadditive operation

$$\underbrace{\mathbb{F}_m G / \mathbb{F}_{m+1} G}_{=\mathbb{E}_m^0 G} \times \underbrace{\mathbb{F}_n G / \mathbb{F}_{n+1} G}_{=\mathbb{E}_n^0 G} \xrightarrow{[-, -]} \underbrace{\mathbb{F}_{m+n} G / \mathbb{F}_{m+n+1} G}_{=\mathbb{E}_{m+n}^0 G}$$

for every $m, n > 0$, so that the weight graded \mathbb{Z} -module $\mathbb{E}^0 G$ inherits the structure of a connected weight graded Lie algebra. To be precise, we consider, in this construction, a \mathbb{Z} -module analogue of the weight graded Lie algebras of §7.3.17 since our sub-quotients $\mathbb{E}_n^0 G = \mathbb{F}_n G / \mathbb{F}_{n+1} G$ are just abelian groups (\mathbb{Z} -modules) in general. The Lie bracket then satisfies the vanishing relation $[x, x] = 0$, for all $x \in \mathbb{E}^0 G$, in addition to the Jacobi relation $[[x, y], z] + [[y, z], x] + [[z, x], y] = 0$, for $x, y, z \in \mathbb{E}^0 G$. This vanishing relation is obvious and the Jacobi relation follows from the Philip Hall identities.

In the case of the group of group-like elements of a complete Hopf algebra, we have the following result:

PROPOSITION 8.2.4. *Let H be any complete Hopf algebra.*

(a) *The sets*

$$\mathbb{F}_n \mathbb{G}(H) = \{g \in \mathbb{G}(H) \mid g - 1 \in \mathbb{F}_n H\}, \quad n > 0,$$

define a filtration of the form §8.2.2(a-b) for the group of group like elements of the Hopf algebra H , and we moreover have

$$\mathbb{G}(H) = \lim_n \mathbb{G}(H) / \mathbb{F}_n \mathbb{G}(H)$$

in this case.

(b) *The sub-quotients of this filtration $\mathbb{E}_n^0 \mathbb{G}(H)$, $n > 0$, are modules over our ground field \mathbb{k} and form a weight graded Lie algebra in the category of \mathbb{k} -modules. The exponential map $\exp : \mathbb{P}(H) \rightarrow \mathbb{G}(H)$ induces an isomorphism of weight graded Lie algebras*

$$\exp : \mathbb{E}^0 \mathbb{P}(H) \xrightarrow{\cong} \mathbb{E}^0 \mathbb{G}(H),$$

where $\mathbb{P}(H) \subset H$ is equipped with the filtration induced by the natural filtration of the complete Hopf algebra H , and $\mathbb{E}^0 \mathbb{P}(H)$ refers to the weight graded Lie algebra associated to this complete Lie algebra (see §§7.3.19-7.3.20).

The result of this proposition is used in the next section where we give a representation of elements in the Malcev completion of free groups.

PROOF. We readily obtain, from the exponential correspondence $g = e^x \Leftrightarrow x = \log(g)$, and the multiplicativity of the filtration of Hopf algebras, that the elements $g \in \mathbb{F}_n \mathbb{G}(H)$ are identified with the exponentials $g = e^x$ of primitive elements such that $x \in \mathbb{P}(H) \cap \mathbb{F}_n H = \mathbb{F}_n \mathbb{P}(H)$. We moreover have

$$x, y \in \mathbb{P}(H) \cap \mathbb{F}_n H \Rightarrow e^x, e^y \equiv 1 \pmod{\mathbb{F}_n H} \Rightarrow e^x \cdot e^y \equiv 1 \pmod{\mathbb{F}_n H}$$

so that each $\mathbb{F}_n \mathbb{G}(H)$ forms a subgroup of $\mathbb{G}(H)$. When we assume $x \in \mathbb{P}(H) \cap \mathbb{F}_n H$, $y \in \mathbb{P}(H) \cap \mathbb{F}_{n+1} H$, we obtain:

$$e^{-y} \cdot e^{-x} \cdot e^{x+y} \equiv 1 \pmod{\mathbb{F}_{n+1} H} \Rightarrow e^{x+y} \equiv e^x \cdot e^y \pmod{\mathbb{F}_{n+1} H}$$

so that the exponential induces a well defined bijection

$$\exp : \mathbf{E}_n^0 \mathbb{P}(H) \xrightarrow{\cong} \mathbf{F}_n G / \mathbf{F}_{n+1} G$$

for every $n > 0$.

Let $\sigma : H \rightarrow H$ denote the antipode of our Hopf algebra. For $x \in \mathbb{P}(H) \cap \mathbf{F}_m H \Rightarrow u = e^x - 1 \in \mathbf{F}_m H$, and $y \in \mathbb{P}(H) \cap \mathbf{F}_n H \Rightarrow v = e^y - 1 \in \mathbf{F}_n H$, we write

$$e^x = 1 + u, \quad e^y = 1 + v, \quad e^{-x} = \sigma(e^x) = 1 + \sigma(u), \quad e^{-y} = \sigma(e^y) = 1 + \sigma(v),$$

where we use $\xi \in \mathbb{P}(H) \Rightarrow e^\xi \in \mathbb{G}(H) \Rightarrow \sigma(e^\xi) = (e^\xi)^{-1} = e^{-\xi}$. The antipode relation implies

$$1 + u + \sigma(u) + u\sigma(u) = 1 \quad \text{and} \quad 1 + v + \sigma(v) + v\sigma(v) = 1$$

and we use the multiplicativity of the filtration of the Hopf algebra to obtain

$$(e^x, e^y) \equiv 1 + uv - vu \equiv 1 + xy - yx \pmod{\mathbf{F}_{m+n+1} H}.$$

This computation implies $(\mathbf{F}_m \mathbb{G}(H), \mathbf{F}_n \mathbb{G}(H)) \subset \mathbf{F}_{m+n} \mathbb{G}(H)$ and proves that the exponential map defines a morphism of Lie algebras.

The relation $\mathbb{G}(H) = \lim_n \mathbb{G}(H) / \mathbf{F}_n \mathbb{G}(H)$ is a straightforward consequence of the identity $H = \hat{H} = \lim_n H / \mathbf{F}_n H$ and this observation completes the proof of the proposition. Note that our requirement $H / \mathbf{F}_1 H = \mathbb{k} \Leftrightarrow \mathbb{1}(H) = \mathbf{F}_1 H$ for a complete Hopf algebra also implies $\mathbb{G}(H) = \mathbf{F}_1 \mathbb{G}(H)$. \square

8.2.5. *Remarks: The equivalence with the category of complete Lie algebras and the Baker-Campbell-Hausdorff formula.* The category of Malcev complete groups is, according to our definition, equivalent to the category of complete Hopf algebras, with an equivalence of categories yielded by the group-like element functor, from complete Hopf algebras to groups. The category of complete Hopf algebras is also equivalent to the category of complete Lie algebras (according to the results of §7.3), with adjoint equivalences of categories yielded by the complete enveloping algebra and primitive elements functors.

We can obviously compose these equivalences of categories to get an equivalence between the category of Malcev complete groups and the category of complete Lie algebras. We then consider the functor which assigns the group $G = \mathbb{G} \hat{\mathbb{U}}(\mathfrak{g})$, to any complete Lie algebra $\mathfrak{g} \in \widehat{\mathcal{L}ie}$. As we have $\mathfrak{g} = \mathbb{P} \hat{\mathbb{U}}(\mathfrak{g})$, the result of Proposition 8.1.5 implies that the exponential map induces a natural bijection $\exp : \mathfrak{g} \xrightarrow{\cong} G$ between the Lie algebra \mathfrak{g} and the associated Malcev complete group $G = \mathbb{G} \hat{\mathbb{U}}(\mathfrak{g})$. In particular, for any $a, b \in \mathfrak{g}$, we have an identity $e^a \cdot e^b = e^c$, between the product of the elements e^a and e^b in the group G , and the exponential of a certain element c in the Lie algebra \mathfrak{g} .

We can use the functoriality of the exponential correspondence to get a universal formula, usually referred to as the Baker-Campbell-Hausdorff formula in the literature, for this Lie algebra element (see for instance [32, §II.6]). We proceed as follows. We first work within a free complete Lie algebra $\mathfrak{g} = \hat{\mathbb{L}}(\mathbb{k}x \oplus \mathbb{k}y)$, where x and y now represent abstract variables, and we use the exponential correspondence to get a Lie power series $\phi(x, y) \in \hat{\mathbb{L}}(\mathbb{k}x \oplus \mathbb{k}y)$ satisfying our relation $e^x \cdot e^y = e^{\phi(x, y)}$ in the tensor algebra $\hat{\mathbb{T}}(\mathbb{k}x \oplus \mathbb{k}y) = \hat{\mathbb{U}} \hat{\mathbb{L}}(\mathbb{k}x \oplus \mathbb{k}y)$. We also have $\phi(x, y) = \log(e^x \cdot e^y)$ and we can use the retraction of Proposition 7.2.8 to get an effective definition of

this Lie power series. We obtain for the first terms:

$$\phi(x, y) = x + y + \frac{1}{2}[x, y] + \frac{1}{12}([[x, y], y] + [[y, x], x]) + \cdots.$$

We then consider the Lie algebra morphism $\mathbb{L}(\mathbb{k}x \oplus \mathbb{k}y) \rightarrow \mathfrak{g}$, mapping our variables (x, y) to any pair of given elements (a, b) in the Lie algebra \mathfrak{g} , and we immediately conclude that we have the relation $e^a \cdot e^b = e^{\phi(a, b)}$ for the Lie algebra element $c = \phi(a, b)$ obtained by the substitution $(x, y) = (a, b)$ in our Lie power series.

The Baker-Campbell-Hausdorff formula can be used to give a direct definition of the Malcev complete group G associated to a Lie algebra \mathfrak{g} , without referring to the theory of Hopf algebras. This approach is used by Bourbaki [32] for instance. We then define G as the set of formal exponential elements e^ξ , where $\xi \in \mathfrak{g}$. We set $e^a \cdot e^b = e^{\phi(a, b)}$ to provide this set $G = \exp \mathfrak{g}$ with a group structure.

8.2.6. *Remarks: The relationship with the notion of a unipotent algebraic group.*

In the case where \mathfrak{g} is a finite dimensional algebra in §8.2.5, the exponential map gives, for any choice of a basis on \mathfrak{g} , an identity between the underlying set of the group G associated to \mathfrak{g} and the affine space \mathbb{k}^N , where we set $N = \dim \mathfrak{g}$. The identity $\mathfrak{g} = \lim_n \mathfrak{g} / \mathbb{F}_n \mathfrak{g}$ is also equivalent to the vanishing relation $\mathbb{F}_{m+1} \mathfrak{g} = 0$ for some $m \geq 0$, and implies that the Lie algebra is nilpotent in the sense that all Lie monomials of weight $> m$ vanish on \mathfrak{g} . From this observation, we deduce that the Baker-Campbell-Hausdorff formula reduces to a finite sum on \mathfrak{g} , and as a consequence, is given by a polynomial expression in our choice of coordinates $G \simeq \mathbb{k}^N$. Thus, when we have $\dim \mathfrak{g} = N$, we obtain that the group G associated to \mathfrak{g} forms an algebraic group in the classical sense of algebraic geometry (see for instance [30]).

If we moreover assume that \mathfrak{g} has a trivial center $[c, -] = 0 \Rightarrow c = 0$, then we can consider the adjoint action $Ad(e^\xi) : x \mapsto e^\xi x e^{-\xi}$ to get an injective morphism $Ad : G \rightarrow \text{End}(\mathfrak{g})$ identifying G with a closed subgroup, defined by a collection of polynomial equations, in the general linear group $GL(\mathfrak{g})$. This statement follows from the relation $e^\xi x e^{-\xi} = x + [\xi, x] \pmod{\mathbb{F}_{s+t+1} \mathfrak{g}}$, valid for all $x \in \mathbb{F}_s \mathfrak{g}$ and $\xi \in \mathbb{F}_t \mathfrak{g}$, and which also implies that our group G is actually unipotent. Recall that an algebraic group is unipotent if and only if this group admits an embedding into a group of upper triangular matrices with unit entries on the diagonal. In our case, such an embedding can be obtained by providing a basis of our Lie algebra reflecting our filtration.

We refer to standard textbooks on algebraic group theory (like [30]) for more complete explanations on the structure of unipotent algebraic groups.

8.3. The Malcev completion of free groups

We now study the Malcev completion of free groups and groups defined by a presentation by generators and relations. To simplify, we focus on finite generation cases. We use the notation $\mathbb{F}(x_1, \dots, x_n)$ for the free group generated by elements x_1, \dots, x_n . We still consider Malcev completions with coefficients in arbitrary field of characteristic zero \mathbb{k} . We have the following result:

PROPOSITION 8.3.1. *For a free group $G = \mathbb{F}(x_1, \dots, x_n)$, we have an isomorphism of complete Hopf algebras*

$$\mathbb{k}[\mathbb{F}(x_1, \dots, x_n)]^\wedge \xrightarrow{\cong} \hat{\mathbb{T}}(\xi_1, \dots, \xi_n),$$

where $\hat{\mathbb{T}}(\xi_1, \dots, \xi_n)$ is a short notation for the complete tensor algebra associated to the free \mathbb{k} -module $M = \mathbb{k}\xi_1 \oplus \dots \oplus \mathbb{k}\xi_n$ equipped with the filtration such that $F_1 M = M$ and $F_s M = 0$ for $s > 1$. This complete tensor algebra is equipped with the canonical Hopf algebra structure of §7.2.6 (see also §7.3.23), so that each generator ξ_i defines a primitive element in $\hat{\mathbb{T}}(\xi_1, \dots, \xi_n)$.

For the primitive part, we have an identity:

$$\mathbb{P} \mathbb{k}[\mathbb{F}(x_1, \dots, x_n)]^\wedge = \hat{\mathbb{L}}(\xi_1, \dots, \xi_n),$$

where $\hat{\mathbb{L}}(\xi_1, \dots, \xi_n)$ is also a short notation for the free complete Lie algebra associated to the free \mathbb{k} -module $M = \mathbb{k}\xi_1 \oplus \dots \oplus \mathbb{k}\xi_n$.

The elements of the Malcev completion of a free group are therefore identified with exponentials of Lie power series (elements of a free complete Lie algebra).

PROOF. The elements ξ_i are primitive by definition of the Hopf algebra structure of the tensor algebra, and the associated exponential elements e^{ξ_i} are group-like by Proposition 8.1.5.

We consider the group morphism $\phi : \mathbb{F}(x_1, \dots, x_n) \rightarrow \mathbb{G}(\hat{\mathbb{T}}(\xi_1, \dots, \xi_n))$ which sends the generating elements of the free group x_i to these group-like elements e^{ξ_i} , and the associated morphism of complete Hopf algebras $\phi_\# : \mathbb{k}[\mathbb{F}(x_1, \dots, x_n)]^\wedge \rightarrow \hat{\mathbb{T}}(\xi_1, \dots, \xi_n)$. We have a Hopf algebra morphism going in the conversion direction $\psi : \hat{\mathbb{T}}(\xi_1, \dots, \xi_n) \rightarrow \mathbb{k}[\mathbb{F}(x_1, \dots, x_n)]^\wedge$ which assigns the logarithm $\log(x_i)$ of the group like elements x_i to the generating elements of the tensor algebra ξ_i .

We have $\phi_\# \cdot \psi(\xi_i) = \exp \log(\xi_i) = \xi_i$ for each i so that $\phi_\# \cdot \psi = id$. We also have $\mathbb{G}(\psi)(\phi(x_i)) = x_i$ for each generator of the free group x_i , where we consider the morphism on group-like elements induced by our complete Hopf algebra morphism ψ . We accordingly have $\mathbb{G}(\psi)\phi = \iota$, where ι refers to the standard morphism $\iota : \mathbb{F}(x_1, \dots, x_n) \rightarrow \mathbb{G} \mathbb{k}[\mathbb{F}(x_1, \dots, x_n)]^\wedge$ defining the unit morphism of the group-like adjunction. We have $\mathbb{G}(\psi)\phi = \iota \Rightarrow \psi\phi_\# = id$ by adjunction. We conclude that $\phi_\#$ and ψ define inverse isomorphisms between the complete group algebra of the free group and the complete tensor algebra.

The second assertion of the proposition follows from the result of Proposition §7.2.14 (see also §7.3.24). \square

8.3.2. *The combinatorial group theory approach of the Malcev completion.* The free Lie algebra $\mathbb{L}(\xi_1, \dots, \xi_n)$ has a definition over \mathbb{Z} and forms a free \mathbb{Z} -module (see [32, II.2.9] or [147, §0.3]). Furthermore, each homogeneous component of the free Lie algebra $\mathbb{L}_r(\xi_1, \dots, \xi_n)$, $r > 0$, admits a basis $h(\xi_1, \dots, \xi_n)$, $h \in H(r)$, where $h(\xi_1, \dots, \xi_n)$ is a Lie monomial. Examples of such monomial basis are associated with Hall sets (see [147, §4] for a general reference on this subject).

The sub-quotients of the lower central series filtration of a free group (see §8.2.2) form, by fundamental results of combinatorial group theory, a free weight graded Lie algebra (over \mathbb{Z})

$$(a) \quad \bigoplus_{s>0} \Gamma_s \mathbb{F}(x_1, \dots, x_n) / \Gamma_{s+1} \mathbb{F}(x_1, \dots, x_n) = \mathbb{L}(\xi_1, \dots, \xi_n),$$

where we assume that each generator ξ_1 is homogeneous of weight 1 (see for instance [32, §II.5.4] or [123, Theorem 5.12]). This statement implies that any element $g(x_1, \dots, x_n)$ in the pro-nilpotent completion of the free group $\mathbb{F}(x_1, \dots, x_n)$ has a

unique expansion

$$(b) \quad g(x_1, \dots, x_n) = x_1^{a_1} \cdots x_n^{a_n} \cdot \prod_{\substack{h \in H(r) \\ r \geq 2}} h(x_1, \dots, x_n)^{a_h},$$

where $a_1, \dots, a_n \in \mathbb{Z}$, $a_h \in \mathbb{Z}$, for all h , and each factor $h(x_1, \dots, x_n) \in \mathbb{F}(x_1, \dots, x_r)$ is obtained by replacing the iterated Lie bracket $[-, -]$ of our Lie monomials $h(\xi_1, \dots, \xi_n)$ by iterated commutators of generating elements in the free group (see [83] for the original statement of this result, see [32, §II.5.4] or [123, Theorem 5.13A] in our reference books on this subject). This process implies that we have $h(\xi_1, \dots, \xi_n) \in \mathbb{L}_r(\xi_1, \dots, \xi_r) \Rightarrow h(\xi_1, \dots, \xi_n) \in \Gamma_r \mathbb{F}(x_1, \dots, x_r)$. The product of our expansion is also performed in the increasing direction of the weight index $r > 0$, and according to a fixed order on each indexing set $H(r)$. The truncated product $x_1^{a_1} \cdots x_n^{a_n} \cdot \prod_{2 \leq r \leq s} (\prod_{h \in H(r)} h(x_1, \dots, x_n)^{a_h})$ represents the image of our element $g(x_1, \dots, x_n)$ in the quotient $\mathbb{F}(x_1, \dots, x_n) / \Gamma_{s+1} \mathbb{F}(x_1, \dots, x_n)$.

Proposition 8.3.1 implies that we have parallel results for the Malcev completion of a free group $\hat{\mathbb{F}}(x_1, \dots, x_n)$. The subquotients of our filtration on $\hat{\mathbb{F}}(x_1, \dots, x_n)$ are identified with a free weight graded Lie algebra, as in (a), but we now take a free Lie algebra over the ground field \mathbb{k} . Each element $g(x_1, \dots, x_n)$ has a unique expansion of the form (b), but we now take exponents in the coefficient field $a_1, \dots, a_n \in \mathbb{k}$, $a_h \in \mathbb{k}$. We use this consequence of Proposition 8.3.1 in the next section.

8.3.3. *The Malcev completion of a group defined by a presentation by generators and relations.* The result of Proposition 8.3.1 can be used to determine the primitive Lie algebra $\mathbb{P} \mathbb{k}[G]^\wedge$ for a group given by a presentation by generators and relations $G = \langle x_1, \dots, x_n : w_0^1 \equiv w_1^1, \dots, w_0^r \equiv w_1^r \rangle$. The definition of a group by such a presentation can be formulated in terms of a reflexive coequalizer of free groups

$$\begin{array}{c} \xleftarrow{s_0} \\ \underbrace{\mathbb{F}(x_1, \dots, x_n, z_1, \dots, z_r)}_{=F_1} \xrightleftharpoons[d_1]{d_0} \underbrace{\mathbb{F}(x_1, \dots, x_n)}_{=F_0} \xrightarrow{\epsilon} \underbrace{\langle x_1, \dots, x_n : w_0^j \equiv w_1^j \rangle}_{=G} \end{array}$$

where d_0, d_1 and s_0 are both the identity on the generating elements x_i , and we set $d_0(z_j) = w_0^j(x_1, \dots, x_n)$, $d_1(z_j) = w_1^j(x_1, \dots, x_n)$ for the remaining variables. The functor $\mathbb{k}[-]^\wedge$ preserves coequalizers by adjunction, and we still have a reflexive coequalizer at the Lie algebra level

$$\begin{array}{c} \xleftarrow{(s_0)_*} \\ \underbrace{\hat{\mathbb{L}}(\xi_1, \dots, \xi_n, \zeta_1, \dots, \zeta_r)}_{=\mathbb{P} \mathbb{k}[F_1]^\wedge} \xrightleftharpoons[(d_1)_*]{(d_0)_*} \underbrace{\hat{\mathbb{L}}(\xi_1, \dots, \xi_n)}_{=\mathbb{P} \mathbb{k}[F_0]^\wedge} \xrightarrow{\epsilon} \mathbb{P} \mathbb{k}[G]^\wedge \end{array}$$

since the primitive element functor is an equivalence of categories (by Theorem 7.3.26, the Milnor-Moore theorem for complete Hopf algebras). The morphisms $(d_0)_*$, $(d_1)_*$ and $(s_0)_*$ occurring in this coequalizer are also given by the identity on the generating elements ξ_i , and we deduce from the exponential correspondence between group-like and primitive elements that we have $(d_0)_*(\zeta_j) = \log(w_0^j(e^{\xi_1}, \dots, e^{\xi_n}))$ and $(d_1)_*(\zeta_j) = \log(w_1^j(e^{\xi_1}, \dots, e^{\xi_n}))$ for the remaining generators ζ_j . We therefore have a presentation (in the complete sense) of the Lie algebra associated to our group.

8.4. Malcev completions in the rational coefficient case

To conclude this chapter, we examine the case $\mathbb{k} = \mathbb{Q}$ of the Malcev completion process. Throughout this section, we use the infinite product expansion §8.3.2(b)

$$(*) \quad g(\xi_1, \dots, \xi_n) = (e^{\xi_1})^{a_1} \cdots (e^{\xi_n})^{a_n} \cdot \prod_{\substack{h \in H(r) \\ r \geq 2}} h(e^{\xi_1}, \dots, e^{\xi_n})^{a_h},$$

for the elements of the completion of a free group $g(\xi_1, \dots, \xi_n) \in \hat{\mathbb{F}}(x_1, \dots, x_n)$, where we set $x_i = e^{\xi_i}$, $i = 1, \dots, n$, and where we also assume $a_1, \dots, a_n \in \mathbb{Q}$, and $a_h \in \mathbb{Q}$, for all $h \in H(r)$, $r \geq 2$. By Proposition 8.3.1, these Malcev group elements $g = g(\xi_1, \dots, \xi_n)$ are identified with group-like elements in the tensor algebra $\hat{\mathbb{T}}(\xi_1, \dots, \xi_n)$. In the rational setting, the existence of such an expansion is a consequence of the single result of Proposition 8.3.1. The factors $h(e^{\xi_1}, \dots, e^{\xi_n})$ can also be obtained as the commutators associated to any (ordered) basis of the summands of homogeneous weight the free Lie algebra over \mathbb{Q} .

Proposition 8.2.4 implies that a Malcev complete group $\hat{G} = \mathbb{G}(H)$ is pro-nilpotent. The exponential correspondence implies that this group \hat{G} is a uniquely divisible group. Indeed, we have $g^n = h \Leftrightarrow n \log(g) = \log(h) \Leftrightarrow g = \exp(1/n \cdot \log(h))$ for any exponent $n > 0$. These properties actually characterize the Malcev completion (see [145, Corollary A.3.7-A.3.8]). We revisit the proof of this result. We start with the following theorem:

THEOREM 8.4.1. *The augmentation morphism $\rho : \mathbb{Q}[\mathbb{G}(H)]^\wedge \rightarrow H$ of the adjunction between groups and complete Hopf algebras is an iso when $\mathbb{k} = \mathbb{Q}$ is our ground field.*

PROOF. We check the case of a complete tensor algebra $H = \hat{\mathbb{T}}(M)$ first. We also assume that M is equipped with a finite basis (ξ_1, \dots, ξ_n) .

We consider the morphism of complete Hopf algebras $\psi : \hat{\mathbb{T}}(M) \rightarrow \mathbb{Q}[\mathbb{G}(H)]^\wedge$ such that $\psi(\xi_i) = \log[e^{\xi_i}]$. We immediately see that $\rho\psi(\xi_i) = \xi_i$, for any basis element $\xi_i \in M$, and we mainly have to check the validity of the converse relation $\psi\rho([g]) = [g]$, for any group like element $g = g(\xi_1, \dots, \xi_n) \in \mathbb{G}\hat{\mathbb{T}}(M)$. We use the infinite product expansion (*). We clearly have the identity $\psi\rho([h(e^{\xi_1}, \dots, e^{\xi_n})]) = [h(e^{\xi_1}, \dots, e^{\xi_n})]$, for any factor of this expansion, and we also see that $\psi\rho([h]) = [h] \Leftrightarrow \psi\rho([h^a]) = [h^a]$ for any rational exponent $a = p/q$ and any $h \in \mathbb{G}\hat{\mathbb{T}}(M)$, because this element $[h^{p/q}]$ is characterized by the relation $[h^{p/q}]^q = [h^p] = [h]^p$ in $\mathbb{G}\hat{\mathbb{T}}(M) \subset \hat{\mathbb{T}}(M)$. We conclude that we have $\psi\rho([g]) = [g]$, as required, for our group-like element $g = g(\xi_1, \dots, \xi_n)$.

We now consider the general case of an arbitrary complete Hopf algebra H . We have $H = \hat{\mathbb{U}}(\mathfrak{g})$ by Theorem 7.3.26 (the Milnor-Moore theorem), where we consider the complete Lie algebra such that $\mathfrak{g} = \mathbb{P}(H)$. We set $G = \mathbb{G}(H) = \mathbb{G}\hat{\mathbb{U}}(\mathfrak{g})$, and we use the exponential mapping $\exp : \xi \mapsto e^\xi$ to get a bijection $\exp : \mathfrak{g} \rightarrow G$. We consider the map $\psi : \mathfrak{g} \rightarrow \mathbb{Q}[G]^\wedge$ which associates the logarithm series $\log[e^\xi] \in \mathbb{Q}[G]^\wedge$ to any $\xi \in \mathfrak{g}$. We have $\rho\psi(\xi) = \log \exp(\xi) = \xi$ in $\hat{\mathbb{U}}(\mathfrak{g})$.

Let us observe that the construction of this mapping is functorial with respect to the Lie algebra \mathfrak{g} , and returns, in the case of a free complete Lie algebra $\mathfrak{g} = \hat{\mathbb{L}}(\xi_1, \dots, \xi_n)$, an inverse of the isomorphism $\rho : \mathbb{Q}[\mathbb{G}\hat{\mathbb{T}}(\xi_1, \dots, \xi_n)] \xrightarrow{\cong} \hat{\mathbb{T}}(\xi_1, \dots, \xi_n)$ (obtained in the first step of this proof) since we have $\hat{\mathbb{U}}\hat{\mathbb{L}}(\xi_1, \dots, \xi_n) = \hat{\mathbb{T}}(\xi_1, \dots, \xi_n)$. From this free case, and by using the functoriality of our mapping

$\psi : \mathfrak{g} \rightarrow \mathbb{Q}[G]^\wedge$ with respect to a Lie algebra morphism $f : \hat{\mathbb{L}}(\xi_1, \xi_2) \rightarrow \mathfrak{g}$, we obtain that the identities $\psi(x_1 + x_2) = \psi(x_1) + \psi(x_2)$ and $\psi([x_1, x_2]) = [\psi(x_1), \psi(x_2)]$ hold in $\mathbb{Q}[G]^\wedge$ for all $x_1, x_2 \in \mathfrak{g}$. We also have $\psi(ax) = a\psi(x)$, for all $a \in \mathbb{Q}$ and $x \in \mathfrak{g}$. Hence, our mapping defines a morphism of complete Lie algebras, from \mathfrak{g} to $\mathbb{Q}[G]^\wedge$, which also admits an extension to the enveloping algebra $\hat{U}(\mathfrak{g})$. The identity $\rho\psi(\xi) = \xi$ for any $\xi \in \mathfrak{g}$, implies that this morphism $\psi : \hat{U}(\mathfrak{g}) \rightarrow \mathbb{Q}[G]^\wedge$ satisfies $\rho\psi = id$ on the whole $\hat{U}(\mathfrak{g})$. For an element $e^\xi \in G$, we moreover have $\psi\rho([e^\xi]) = \psi(\exp \xi) = \exp \log[e^\xi] = [e^\xi]$ in the complete group algebra $\mathbb{Q}[G]^\wedge$, and hence, we also have the relation $\psi\rho = id$ on $\mathbb{Q}[G]^\wedge$. We conclude that the morphism $\rho : \mathbb{Q}[G]^\wedge \rightarrow \hat{U}(\mathfrak{g})$ is an iso, and the proof of our theorem is complete. \square

This theorem admits the following corollaries:

PROPOSITION 8.4.2. *If we take the rational field as coefficient field $\mathbb{k} = \mathbb{Q}$, then:*

- (a) *The group-like element functor, from complete Hopf algebras to groups, is full and faithful, so that the category of Malcev complete groups forms a full subcategory of the category of groups equivalent to the category of complete Hopf algebras.*
- (b) *The Malcev completion functor $\hat{G} = \mathbb{G} \mathbb{Q}[G]^\wedge$ is idempotent, and a group G is Malcev complete if and only if we have $G = \hat{G}$.*

PROOF. These assertions are immediate consequences of the result of Theorem 8.4.1. \square

In addition, we have the following result:

PROPOSITION 8.4.3. *A pro-nilpotent group G is Malcev complete in our sense if and only if this group is uniquely divisible.*

PROOF. We closely follow the argument line of [32, §II.6, Exercise 4], which we complete by our statements on complete Hopf algebras. We have already checked that a Malcev complete group is uniquely divisible, and we aim to prove the converse implication. We can restrict ourselves to the case of a nilpotent group G . We aim to define a nilpotent Lie algebra \mathfrak{g} , naturally associated to G , and such that $G = \mathbb{G} \hat{U}(\mathfrak{g})$.

We use the expansion (*) for the elements of the Malcev completion of a free group, which we also identify with the set of group-like elements in a complete tensor algebra. In the case $g(\xi_1, \xi_2) = e^{\xi_1 + \xi_2}$ and $g(\xi_1, \xi_2) = e^{[\xi_1, \xi_2]}$, we get a formula for the sum and the Lie bracket in terms of commutators of group-like elements. We define our Lie algebra \mathfrak{g} by the same underlying set as the group G , and we equip this set with the sum and Lie bracket defined by these universal formulas. We use the assumption that G is uniquely divisible to provide \mathfrak{g} with a \mathbb{Q} -module structure. We see that the structure relations of Lie algebras hold in \mathfrak{g} because these relations are satisfied by our universal formulas, within the completed tensor algebra. We also readily obtain that the Lie algebra \mathfrak{g} is nilpotent. We have bijections $\mathfrak{g} \simeq \mathbb{G} \hat{U}(\mathfrak{g}) \simeq G$, and we see retrieve the multiplication of the group G in $\mathbb{G} \hat{U}(\mathfrak{g})$, because this is so for the Malcev completion of a free group. We conclude that our group G is Malcev complete as required. \square

The Malcev Completion for Groupoids and Operads

In the previous chapter §7, we recalled that the adjunction between groups and Hopf algebras can be used to define a rationalization process, the Malcev completion, for groups.

To be more explicit, recall that the free \mathbb{k} -module $\mathbb{k}[G]$ associated to a group G inherits a Hopf algebra structure so that the mapping $\mathbb{k}[-] : G \mapsto \mathbb{k}[G]$ defines a functor from the category of groups $\mathcal{G}rp$ to the category of Hopf algebras $\mathcal{H}opf\mathcal{G}rp$. The other way round, we have a functor from Hopf algebras to groups, defined by observing that the set of group like elements $\mathbb{G}(H)$ in a Hopf algebra H inherits a group structure, and we checked that this functor $\mathbb{G} : \mathcal{H}opf\mathcal{G}rp \rightarrow \mathcal{G}rp$ forms a right adjoint of the group algebra functor $\mathbb{k}[-] : \mathcal{G}rp \rightarrow \mathcal{H}opf\mathcal{G}rp$. To obtain our Malcev completion functor in §8, we consider an extension of this adjunction relation, where the category of plain Hopf algebras is replaced by a category of complete Hopf algebras. The complete Hopf algebra $\mathbb{k}[G]^\wedge$ associated to a group G is precisely defined as the completion $\mathbb{k}[G]^\wedge = \lim_n \mathbb{k}[G] / \mathbb{I}^n \mathbb{k}[G]$ of the Hopf algebra associated to G with respect to the powers of the augmentation ideal $\mathbb{I} \mathbb{k}[G] = \ker(\epsilon : \mathbb{k}[G] \rightarrow \mathbb{k})$, and the completion of the group G is defined by the set of group like elements $\hat{G} = \mathbb{G} \mathbb{k}[G]^\wedge$ associated to this completed Hopf algebra $\mathbb{k}[G]^\wedge$.

In §8, we also crucially assume that the ground ring \mathbb{k} is a field of characteristic 0. The elements of the group \hat{G} are then identified with exponentials $g = e^x$ such that x belongs to the Lie algebra of primitive elements in $\mathbb{k}[G]^\wedge$. This representation enables us to define powers g^α for arbitrary exponents $\alpha \in \mathbb{k}$ in \hat{G} . In the case $\mathbb{k} = \mathbb{Q}$, our construction therefore returns a rationalization of the group G . The case $\mathbb{k} = \mathbb{C}$ of our construction will be used in the next chapter, for the definition of the Drinfeld associator. This application motivates us to keep the general case of a characteristic zero field under consideration in our constructions.

Throughout this chapter, we still assume all that the ground ring \mathbb{k} is a field such that $\mathbb{Q} \subset \mathbb{k}$. Our first purpose is to check that the Malcev completion process for groups extends to groupoids. Then we prove that the obtained completion functor on groupoids preserves symmetric monoidal structures, and hence can be applied to operads arity-wise in order to yield a Malcev completion functor for operads in groupoids. Some care is necessary when we deal with groupoids, and not all arguments are generalizable, since the morphism sets of groupoids, as opposed to the underlying set of a group, are not naturally pointed.

In a first section (§9.1), we define the notion of a Hopf groupoid, extending the classical notion of a Hopf algebra, which we need to form the Hopf side of our completion process in the groupoid context. The definition of the Malcev

completion functor for groupoids itself is addressed in the second section of the chapter (§9.2) and the applications to operads in the third section (§9.3).

9.1. The notion of a Hopf groupoid

Like Hopf algebras, the Hopf groupoids, which we consider in our completion process, are defined by replacing the morphism sets of plain groupoids by coalgebras and by using tensor product operations instead of cartesian structures. The goal of this section is to check the application of this idea and to make the definition of a Hopf groupoid explicit.

We follow the same plan as in §7.1. To begin with, we make explicit the definition of a Hopf category, which parallels the notion of a bialgebra. We address the definition of Hopf groupoids afterwards, and we complete our account with the definition of the generalization to groupoids of the group algebras of §7.1.

9.1.1. *Hopf categories.* In §7.1, we define (cocommutative) bialgebras as unitary associative algebras (or monoids) in the category of counitary cocommutative coalgebras. The Hopf categories which we consider are small categories enriched in counitary cocommutative coalgebras, and are defined by applying the general concepts of §0.13 to this instance of symmetric monoidal category $\mathcal{C}om_+^c$. This process makes sense in any (lower level) base symmetric monoidal category where the category of counitary cocommutative coalgebras can be defined. For the moment we focus on the case of counitary cocommutative coalgebras in \mathbb{k} -modules $\mathcal{C}om_+^c = \text{Mod } \mathcal{C}om_+^c$. In the next section, we will consider counitary cocommutative coalgebras in the category of complete filtered modules of §7.3.

Thus, a Hopf category in our sense is a small category \mathcal{H} , equipped with a hom-bifunctor towards the category of counitary cocommutative coalgebras $\text{Hom}_{\mathcal{H}}(-, -) : \mathcal{H}^{op} \times \mathcal{H} \rightarrow \mathcal{C}om_+^c$, unit morphisms

$$(a) \quad \mathbb{k} \xrightarrow{\eta} \text{Hom}_{\mathcal{H}}(X, X), \quad \text{for } X \in \mathcal{H},$$

and composition morphisms

$$(b) \quad \text{Hom}_{\mathcal{H}}(Y, Z) \otimes \text{Hom}_{\mathcal{H}}(X, Y) \xrightarrow{\mu} \text{Hom}_{\mathcal{H}}(X, Z), \quad \text{for all } X \in \mathcal{H},$$

satisfying the usual unit and associativity axioms of categories within the symmetric monoidal category of counitary cocommutative cocoalgebras (see §0.12). Recall that we also assume that the structure morphisms (a-b) are left invariant under the action of the morphisms of the plain category underlying \mathcal{H} on the hom-objects. We revisit this correspondence in the next paragraph.

In applications, we also use the classical notation $id_X \in \text{Hom}_{\mathcal{H}}(X, X)$ for the homomorphism such that $\eta(1) = id_X$, and which defines an analogue of the identity morphism in our hom-objects. Similarly, we use the notation $f \circ g$ (or just fg) for the image of homomorphisms under the composition morphism (b).

9.1.2. *Morphisms and homomorphisms in Hopf categories.* In §0.13, we briefly mention that we can define a mapping between the morphism sets $\text{Mor}_{\mathcal{C}}(-, -)$ of an enriched category \mathcal{C} and the hom-objects $\text{Hom}_{\mathcal{C}}(-, -)$. In the general case of categories enriched over an abstract symmetric monoidal category \mathcal{M} , this mapping is defined by a morphism $\iota_{\#} : \mathbb{1}[\text{Mor}_{\mathcal{C}}(X, Y)] \rightarrow \text{Hom}_{\mathcal{C}}(X, Y)$, where $\mathbb{1}[\text{Mor}_{\mathcal{C}}(X, Y)]$ denotes the coproduct, over the morphism set $\text{Mor}_{\mathcal{C}}(X, Y)$, of copies of the unit object of the category \mathcal{M} .

In the case of a Hopf category $\mathcal{C} = \mathcal{H}$, we consider the coalgebra $\mathbb{k}[\mathbf{Mor}_{\mathcal{H}}(X, Y)]$ associated to the set $\mathbf{Mor}_{\mathcal{H}}(X, Y)$, and where the elements $[f]$, associated to morphisms $f \in \mathbf{Mor}_{\mathcal{H}}(X, Y)$, are group-like. The morphism $\eta : \mathbb{k} \rightarrow \mathbf{Hom}_{\mathcal{H}}(X, X)$, which models the identity morphism associated to any object $X \in \mathbf{Ob} \mathcal{H}$, is formally determined by the group-like element $id_X \in \mathbf{Hom}_{\mathcal{H}}(X, X)$ such that $\eta(1) = id_X$. Our mapping

$$(a) \quad \iota_{\#} : \mathbb{k}[\mathbf{Mor}_{\mathcal{H}}(X, Y)] \rightarrow \mathbf{Hom}_{\mathcal{H}}(X, Y)$$

is defined by $\iota_{\#}[f] = f_*(id_X)$, where we consider the image of this group-like element $id_X \in \mathbf{Hom}_{\mathcal{H}}(X, X)$ under the hom-object morphism $f_* : \mathbf{Hom}_{\mathcal{H}}(X, X) \rightarrow \mathbf{Hom}_{\mathcal{H}}(X, Y)$ associated to f . The homomorphism $\iota_{\#}[f]$ is group-like in $\mathbf{Hom}_{\mathcal{H}}(X, Y)$ (because f_* is a morphism of counitary cocommutative coalgebras) and therefore our mapping defines a morphism of counitary cocommutative coalgebras from $\mathbb{k}[\mathbf{Mor}_{\mathcal{H}}(X, Y)]$ to $\mathbf{Hom}_{\mathcal{H}}(X, Y)$. In this construction, we can equivalently take $\iota_{\#}[f] = f^*(id_Y)$ since, in the case of the unit morphisms, the invariance requirements of §9.1.1 imply $f_*(id_X) = f^*(id_Y)$.

By adjunction, the morphism of counitary cocommutative coalgebras (a) is equivalent to a mapping

$$(b) \quad \iota : \mathbf{Mor}_{\mathcal{H}}(X, Y) \rightarrow \mathbb{G}(\mathbf{Hom}_{\mathcal{H}}(X, Y))$$

which assigns the group-like element $\iota(f) = f_*(id_X) = f^*(id_Y) \in \mathbf{Hom}_{\mathcal{H}}(X, Y)$ to any $f \in \mathbf{Mor}_{\mathcal{H}}(X, Y)$.

The invariance of the composition operation on hom-objects with respect to the action of morphisms implies that the mapping $f_* : \mathbf{Hom}_{\mathcal{H}}(-, X) \rightarrow \mathbf{Hom}_{\mathcal{H}}(-, Y)$ associated to any morphism $f \in \mathbf{Mor}_{\mathcal{H}}(X, Y)$ is also identified with the composition operation $f_*(u) = \iota(f) \circ u$, where we consider the homomorphism $\iota(f) \in \mathbf{Hom}_{\mathcal{H}}(X, Y)$ associated to f . For the mapping $f^* : \mathbf{Hom}_{\mathcal{H}}(Y, -) \rightarrow \mathbf{Hom}_{\mathcal{H}}(X, -)$ we similarly obtain $f^*(u) = u \circ \iota(f)$.

Our mapping (b) also satisfies $\iota(id_X) = id_X$ and $\iota(f \circ g) = \iota(f) \circ \iota(g)$ by functoriality of the action of morphisms on hom-objects. Thus the unit and composition structure of the hom-objects $\mathbf{Hom}_{\mathcal{H}}(X, Y)$ extends the unit and composition structure of the plain set-theoretic category \mathcal{H} .

In practice, we define Hopf categories by giving the underlying category \mathcal{H} , the hom-coalgebras $\mathbf{Hom}_{\mathcal{H}}(X, Y)$, the mapping (b), which associates a group-like element in the hom-object $\mathbf{Hom}_{\mathcal{H}}(X, Y)$ to any plain morphism $f \in \mathbf{Mor}_{\mathcal{H}}(X, Y)$, and the extension of the composition of morphisms to the whole hom-objects. In applications, we often assume that the maps $\iota : \mathbf{Mor}_{\mathcal{H}}(X, Y) \rightarrow \mathbb{G}(\mathbf{Hom}_{\mathcal{H}}(X, Y))$ is an embedding so that this mapping identifies the morphisms of our category \mathcal{H} with a subset of the group-like elements in the hom-objects.

9.1.3. *Hopf groupoids.* We define a Hopf groupoid as a Hopf category \mathcal{G} , where every morphism is invertible (thus, the underlying category of \mathcal{G} is a groupoid in the classical sense), and where we have an extra operation on hom-objects

$$(a) \quad \mathbf{Hom}_{\mathcal{G}}(X, Y) \xrightarrow{\sigma} \mathbf{Hom}_{\mathcal{G}}(Y, X),$$

defined for all $X, Y \in \text{Ob } \mathcal{G}$, such that the diagrams

$$(b) \quad \begin{array}{ccccc} \text{Hom}_{\mathcal{G}}(X, Y) & \xrightarrow{\epsilon} & \mathbb{k} & \xrightarrow{\eta} & \text{Hom}_{\mathcal{G}}(X, X) \\ \Delta \downarrow & & & & \uparrow \mu \\ \text{Hom}_{\mathcal{G}}(X, Y) \otimes \text{Hom}_{\mathcal{G}}(X, Y) & \xrightarrow{\sigma \otimes id} & & & \text{Hom}_{\mathcal{G}}(Y, X) \otimes \text{Hom}_{\mathcal{G}}(X, Y) \end{array}$$

and

$$(c) \quad \begin{array}{ccccc} \text{Hom}_{\mathcal{G}}(X, Y) & \xrightarrow{\epsilon} & \mathbb{k} & \xrightarrow{\eta} & \text{Hom}_{\mathcal{G}}(Y, Y) \\ \Delta \downarrow & & & & \uparrow \mu \\ \text{Hom}_{\mathcal{G}}(X, Y) \otimes \text{Hom}_{\mathcal{G}}(X, Y) & \xrightarrow{id \otimes \sigma} & & & \text{Hom}_{\mathcal{G}}(X, Y) \otimes \text{Hom}_{\mathcal{G}}(Y, X) \end{array}$$

commute. We naturally assume in this definition that our operation σ is defined by a morphism of counitary cocommutative coalgebras.

We immediately see that a Hopf algebra is identified with a Hopf groupoid with one object, and our extra structure is an obvious generalization of the notion of antipode attached to Hopf algebras. We therefore keep the same name, antipode, to refer to these morphisms.

The relations formulated in our diagrams are naturally coalgebra analogues of the inversion relation of morphisms in groupoids. For a group-like element f , representing a morphism in \mathcal{G} , the relations read $f \cdot \sigma(f) = id$, $\sigma(f) \cdot f = id$, and hence amounts to the requirement that f is invertible with $\sigma(f) = f^{-1}$ as inverse. From this observation and the uniqueness of inverse, we also deduce that the antipode extends the inversion operation for the morphisms of the underlying category of our Hopf groupoid.

One can prove, by an easy extension of the standard argument in the Hopf algebra context, that the antipode operation in a Hopf groupoid is unique and satisfies the relation $\sigma(id_X) = id_X$, for any $X \in \mathcal{G}$, as well as $\sigma(u \circ v) = \sigma(v) \circ \sigma(u)$, for any pair of composable homomorphisms $u \in \text{Hom}_{\mathcal{G}}(Y, Z)$, $v \in \text{Hom}_{\mathcal{G}}(X, Y)$.

9.1.4. *The category of Hopf categories and of Hopf groupoids.* We have a natural notion of morphism associated to Hopf categories, so that Hopf categories form a category $\mathcal{HopfCat}$.

To be explicit, a morphism of Hopf categories $\phi : \mathcal{G} \rightarrow \mathcal{H}$ consists of a functor between the underlying set-theoretic categories of \mathcal{G} and \mathcal{H} , together with a collection of coalgebra morphisms

$$(a) \quad \text{Hom}_{\mathcal{G}}(X, Y) \xrightarrow{\phi} \text{Hom}_{\mathcal{H}}(\phi X, \phi Y),$$

preserving the unit and composition structure on hom-coalgebras, and natural in $X, Y \in \mathcal{G}$ with respect to the action of the morphisms on hom-objects.

In the approach of §9.1.2, the assumption that our morphisms (a) are natural amounts to the requirement that these morphisms fit in commutative diagrams

$$(b) \quad \begin{array}{ccc} \text{Mor}_{\mathcal{G}}(X, Y) & \xrightarrow{\phi} & \text{Mor}_{\mathcal{H}}(\phi X, \phi Y) \quad , \\ \downarrow & & \downarrow \\ \mathbb{G}(\text{Hom}_{\mathcal{G}}(X, Y)) & \xrightarrow[\mathbb{G}(\phi)]{\dots\dots\dots} & \mathbb{G}(\text{Hom}_{\mathcal{H}}(\phi X, \phi Y)) \end{array}$$

for all $X, Y \in \mathcal{G}$, and hence, extend the mapping defined by our functor at the level of the morphisms of the underlying categories of \mathcal{G} and \mathcal{H} .

We define the category of Hopf groupoids $\mathcal{H}opf\mathcal{G}rd$ as the full subcategory of the category of Hopf categories generated by Hopf groupoids. We should note that a morphism of Hopf groupoids automatically preserves the extra structure given by the inversion operations (this assertion is a variation of the uniqueness of inversion morphisms in Hopf algebras). Recall that we use the notation $\mathcal{G}rd$ for the category of groupoids.

We have the following result, extending the classical adjunction relation between groups and Hopf algebras:

PROPOSITION 9.1.5.

- (a) *The coalgebras $\mathbb{k}[\mathbf{Mor}_{\mathcal{G}}(X, Y)]$ associated to the morphism sets of a groupoid \mathcal{G} define the hom-objects of a Hopf groupoid $\mathbb{k}[\mathcal{G}]$ with \mathcal{G} as underlying groupoid in sets.*
- (b) *The set of group-like elements $\mathbb{G}(\mathbf{Hom}_{\mathcal{H}}(X, Y))$ associated to the hom-coalgebras of a Hopf groupoid \mathcal{H} form the hom-objects of a groupoid $\mathbb{G}(\mathcal{H})$, naturally associated to \mathcal{H} , and the mapping $\mathbb{G} : \mathcal{H} \mapsto \mathbb{G}(\mathcal{H})$ gives a right adjoint of the functor $\mathbb{k}[-] : \mathcal{G}rd \rightarrow \mathcal{H}opf\mathcal{G}rd$ defined in assertion (a).*

PROOF. The definition of the Hopf groupoid $\mathbb{k}[\mathcal{G}]$ in assertion (a) is a straightforward extension of the definition of the Hopf algebra $\mathbb{k}[G]$ in the group context, and similarly as regards the definition of a groupoid structure on the group-like element sets $\mathbb{G}(\mathbf{Hom}_{\mathcal{H}}(X, Y))$ associated to a Hopf groupoid \mathcal{H} in assertion (b). One can also readily check that the adjunction relations between coalgebra morphisms $f : \mathbb{k}[X] \rightarrow C$ and set maps $g : X \rightarrow \mathbb{G}(C)$ make morphisms of Hopf groupoids $f : \mathbb{k}[\mathcal{G}] \rightarrow \mathcal{H}$ correspond to groupoid morphisms $g : \mathcal{G} \rightarrow \mathbb{G}(\mathcal{H})$ so that the mappings $\mathbb{k}[-] : \mathcal{G} \mapsto \mathbb{k}[\mathcal{G}]$ and $\mathbb{G} : \mathcal{H} \mapsto \mathbb{G}(\mathcal{H})$ define adjoint functors between the category of groupoids $\mathcal{G}rd$ and the category of Hopf groupoids $\mathcal{H}opf\mathcal{G}rd$. \square

9.2. The Malcev completion for groupoids

To obtain the Malcev completion of groupoids, we consider, as in the group context, an extension of the adjunction relation of §9.1.5 to complete Hopf groupoids. The goal of this section is to address this construction of the Malcev completion.

In §9.1, we mention that our fundamental definitions make sense in any ambient symmetric monoidal category. To define our complete Hopf groupoids, we work within the symmetric monoidal category of complete filtered modules of §7.3. In a first step, a briefly review the concepts of §9.1 in order to make this definition explicit.

9.2.1. *Complete Hopf categories and complete Hopf groupoids.* First, in order to get the notion of a category enriched in complete counitary cocommutative coalgebras, we just replace the category of plain counitary cocommutative coalgebras in the definition of §9.1.1 by the category of counitary cocommutative coalgebras in complete filtered modules $\widehat{\mathcal{C}om}_+^c = \widehat{\mathcal{M}od}\mathcal{C}om_+^c$. Thus, we consider a hom-bifunctor with values in that category

$$\mathbf{Hom}_{\mathcal{H}}(-, -) : \mathcal{H}^{op} \times \mathcal{H} \rightarrow \widehat{\mathcal{C}om}_+^c.$$

In the definition of the unit morphisms §9.1.1(a) and of the composition morphisms §9.1.1(b), we also deal the symmetric monoidal structure of complete counitary cocommutative coalgebras, and we have to replace the ordinary tensor product by the completed tensor product of §7.3.12. The structure of a groupoid enriched in complete filtered modules is defined similarly, by assuming that the antipodes of §9.1.3 are morphisms of complete counitary cocommutative coalgebras, and by taking completed tensor products instead of ordinary tensor products in the diagrams of §9.1.3.

Recall that the ground field \mathbb{k} is identified with a complete filtered module equipped with a trivial filtration and forms a unit for the completed tensor product. The unit morphisms of a category enriched in complete counitary cocommutative coalgebras are therefore equivalent to ordinary unit morphisms of counitary cocommutative coalgebras §9.1.1(a). The preservation of filtration, which we require for morphisms in complete filtered module in general, is automatically fulfilled for these unit morphisms. The preservation of counitary cocommutative coalgebra structures is equivalent to the requirement that the element $id_X = \eta(1)$ associated to each unit morphism $\eta : \mathbb{k} \rightarrow \text{Hom}_{\mathcal{H}}(X, X)$ is group-like as an element of the complete counitary cocommutative coalgebra $\text{Hom}_{\mathcal{H}}(X, X)$, where we use the definition of §8.1.2 for this notion of group-like element in the complete sense.

In the definition of the composition operations of §9.1.1(b), we have to replace the ordinary tensor product by the completed tensor product of §7.3.12. The composition operations can still be identified with extensions of ordinary filtration preserving composition products, as in the Hopf algebra case (see §7.3.14), but we need to work at the level of the completed tensor product in order to get the coalgebra structure of our hom-objects, and hence, to check the preservation of coalgebra structures by our composition operations.

The observations of §9.1.2 have a straightforward extension in the case of complete counitary cocommutative coalgebras, so that a group-like element in the complete sense $\iota(f) \in \mathbb{G}(\text{Hom}_{\mathcal{H}}(X, Y))$ is associated to each morphism of our category $f \in \text{Mor}_{\mathcal{H}}(X, Y)$. The covariant (respectively, contravariant) action of morphisms $f \in \text{Mor}_{\mathcal{H}}(X, Y)$ on hom-objects is also identified with the composition operation $f_*(u) = \iota(f) \circ u$ (respectively, $f^*(u) = u \circ \iota(f)$).

9.2.2. *The category of complete Hopf categories and of complete Hopf groupoids.* The definition of a morphism of Hopf category (respectively, groupoid) in §9.1.4 has an obvious generalization in the complete setting. In §7.3.15, we introduce a connectedness condition for the definition of the subcategory of complete Hopf algebras within the category of Hopf algebras in complete filtered modules. In the Hopf category case, we consider categories enriched in complete counitary cocommutative coalgebras \mathcal{H} such that the augmentation $\epsilon : \text{Hom}_{\mathcal{H}}(X, Y) \rightarrow \mathbb{k}$ induces an iso between the quotient $\text{Hom}_{\mathcal{H}}(X, Y) / \mathbf{F}_1 \text{Hom}_{\mathcal{H}}(X, Y)$ and the ground field \mathbb{k} . We reserve the expression of complete Hopf category for the enriched categories which satisfy this connectedness condition and we use the notation $\widehat{\mathcal{H}opfCat}$ for this subcategory of the category of categories enriched in complete counitary cocommutative coalgebras. We use the same convention, and take the same connectedness requirement, to define a category of complete Hopf groupoids such that $\widehat{\mathcal{H}opfGrd} \subset \widehat{\mathcal{H}opfCat}$.

9.2.3. *The completion of Hopf groupoids.* The natural filtration of Hopf algebras, arising from the tensor powers of the augmentation ideal, has a natural generalization in the context of Hopf groupoids.

To be explicit, let $\mathcal{H} \in \mathcal{H}opf\mathcal{G}rd$ be a Hopf groupoid. For any $X, Y \in \mathcal{H}$, we consider the nested sequence

$$\mathbf{Hom}_{\mathcal{H}}(X, Y) = \mathbb{I}^0(\mathbf{Hom}_{\mathcal{H}}(X, Y)) \supset \mathbb{I}^1(\mathbf{Hom}_{\mathcal{H}}(X, Y)) \supset \dots \supset \mathbb{I}^n(\mathbf{Hom}_{\mathcal{H}}(X, Y)) \supset \dots,$$

where $\mathbb{I}^n \mathbf{Hom}_{\mathcal{H}}(X, Y)$ is the submodule of $\mathbf{Hom}_{\mathcal{H}}(X, Y)$ spanned by the n -fold composites $f_1 \dots f_n$ of homomorphisms f_i such that $\epsilon(f_i) = 0$. Equivalently, we assume that each f_i lies in the kernel of the augmentation on hom-objects $\mathbb{I} \mathbf{Hom}_{\mathcal{H}}(-, -) = \ker\{\mathbf{Hom}_{\mathcal{H}}(-, -) \xrightarrow{\epsilon} \mathbb{k}\}$ which gives the $n = 1$ layer of our sequence.

The preservation of the counitary cocommutative coalgebra structure by the composition operations of \mathcal{H} implies, as in the Hopf algebra case (see §8.1.1), that we have the inclusion relation $\Delta(\mathbb{I}^n(\mathbf{Hom}_{\mathcal{H}}(X, Y))) \subset \sum_{p+q=n} \mathbb{I}^p(\mathbf{Hom}_{\mathcal{H}}(X, Y)) \otimes \mathbb{I}^q(\mathbf{Hom}_{\mathcal{H}}(X, Y))$, for each $n \in \mathbb{N}$, so that the coproduct defines a filtration preserving morphism for this choice of filtration. The counit $\epsilon : \mathbf{Hom}_{\mathcal{H}}(X, Y) \rightarrow \mathbb{k}$ trivially defines a filtration preserving morphism too.

Hence, each hom-object $\mathbf{Hom}_{\mathcal{H}}(X, Y)$ of our Hopf groupoid \mathcal{H} canonically inherits the structure of a counitary cocommutative coalgebra in filtered modules, of which we perform the completion

$$\mathbf{Hom}_{\mathcal{H}}(X, Y)^\wedge = \lim_n \mathbf{Hom}_{\mathcal{H}}(X, Y) / \mathbb{I}^n(\mathbf{Hom}_{\mathcal{H}}(X, Y))$$

to get a complete counitary cocommutative coalgebra $\mathbf{Hom}_{\mathcal{H}}(X, Y)^\wedge$, for each pair $X, Y \in \mathcal{H}$. Recall that the filtration associated to such a completed module satisfies $\mathbf{Hom}_{\mathcal{H}}(X, Y)^\wedge / \mathbb{F}_1 \mathbf{Hom}_{\mathcal{H}}(X, Y)^\wedge = \mathbf{Hom}_{\mathcal{H}}(X, Y) / \mathbb{I}^n(\mathbf{Hom}_{\mathcal{H}}(X, Y))$, for every $n \in \mathbb{N}$. In the case $n = 1$, we have $\mathbb{I}(\mathbf{Hom}_{\mathcal{H}}(X, Y)) = \ker(\epsilon : \mathbf{Hom}_{\mathcal{H}}(X, Y) \rightarrow \mathbb{k}) \Leftrightarrow \mathbf{Hom}_{\mathcal{H}}(X, Y) / \mathbb{I}(\mathbf{Hom}_{\mathcal{H}}(X, Y)) = \mathbb{k}$, and we deduce from this relation that the augmentation of $\mathbf{Hom}_{\mathcal{H}}(X, Y)^\wedge$, obtained by completion from the augmentation of the ordinary coalgebra $\mathbf{Hom}_{\mathcal{H}}(X, Y)$, induces an iso between the quotient module $\mathbf{Hom}_{\mathcal{H}}(X, Y)^\wedge / \mathbb{F}_1 \mathbf{Hom}_{\mathcal{H}}(X, Y)^\wedge$ and the ground field \mathbb{k} .

The unit morphisms of \mathcal{H} have a trivial prolongation $\eta : \mathbb{k} \rightarrow \mathbf{Hom}_{\mathcal{H}}(X, X)^\wedge$ for every $X \in \mathcal{H}$, and so does the mapping $\iota : f \mapsto \iota(f)$ which associates a group-like homomorphism to every morphism of the category underlying \mathcal{H} . The composition operations of \mathcal{H} trivially preserve the filtration of our counitary cocommutative coalgebras, and hence induce composition operations at the level of our completed hom-objects $\mathbf{Hom}_{\mathcal{H}}(-, -)^\wedge$. The relations satisfied by antipodes imply, as in the Hopf algebra case, that the antipodes of our Hopf groupoid preserve filtrations too and hence admit an extension to the completed hom-objects as well.

We conclude from these observations that the collection of complete counitary cocommutative coalgebras $\mathbf{Hom}_{\mathcal{H}}(X, Y)^\wedge$, $X, Y \in \mathcal{H}$, define the hom-objects of a complete Hopf groupoid $\hat{\mathcal{H}}$ naturally associated to \mathcal{H} .

9.2.4. *The complete Hopf groupoid and group-like element functors.* We associate a complete Hopf groupoid $\mathbb{k}[\mathcal{G}]^\wedge$ to any groupoid \mathcal{G} by taking the completion §9.2.3 of the Hopf groupoid $\mathbb{k}[\mathcal{G}]$ of Proposition 9.1.5. This complete Hopf groupoid $\mathbb{k}[\mathcal{G}]^\wedge$ has \mathcal{G} as underlying groupoid and the completed modules

$$\mathbf{Hom}_{\mathcal{G}}(X, Y)^\wedge = \lim_n \mathbb{k}[\mathbf{Mor}_{\mathcal{G}}(X, Y)] / \mathbb{I}^n \mathbb{k}[\mathbf{Mor}_{\mathcal{G}}(X, Y)]$$

as hom-coalgebras. The outcome of this construction is a functor $\mathbb{k}[-]^\wedge : \mathcal{G}rd \rightarrow \widehat{\mathcal{H}opf\mathcal{G}rd}$ from the category of groupoids $\mathcal{G}rd$ to the category of complete Hopf groupoids $\widehat{\mathcal{H}opf\mathcal{G}rd}$.

In the converse direction, we see that the group-like element functor in Proposition 9.1.5 has an obvious complete version, so that a groupoid of group-like elements $\mathbb{G}(\mathcal{H})$ can be associated to any complete Hopf groupoid \mathcal{H} . This groupoid has the same object set as the underlying groupoid of \mathcal{H} and the sets of group-like elements in the complete sense

$$\mathbb{G}(\text{Hom}_{\mathcal{H}}(X, Y)) = \{f \in \text{Hom}_{\text{cat}}(X, Y) \mid \epsilon(f) = 1 \text{ and } \Delta(f) = f \hat{\otimes} f\}$$

as morphism sets (see §8.1.2). The identity morphisms and the composition operation are yielded by the unit and composition on hom-objects, as in the construction of Proposition 9.1.5. The inverse of morphisms in $\mathbb{G}(\mathcal{H})$ is also given by the antipode of the complete Hopf groupoid \mathcal{H} .

Proposition 9.1.5(b) has the following analogue in the context of complete Hopf groupoids:

PROPOSITION 9.2.5. *The complete Hopf groupoid $\mathbb{k}[-]^\wedge : \mathcal{G} \mapsto \mathbb{k}[\mathcal{G}]^\wedge$ and group-like functors $\mathbb{G} : \mathcal{H} \rightarrow \mathbb{G}(\mathcal{H})$ obtained by the construction of this paragraph §9.2.4 define a pair of adjoint functors $\mathbb{k}[-]^\wedge : \text{Grd} \rightleftarrows \widehat{\mathcal{H}\text{opfGrd}} : \mathbb{G}$ between the category of groupoids Grd and the category of complete Hopf groupoids $\widehat{\mathcal{H}\text{opfGrd}}$.*

PROOF. This proposition follows from a straightforward extension of the arguments of Proposition 8.1.3, where we define the adjunction between groups and complete Hopf algebras. \square

The definition of a Hopf groupoid in §9.1.3 implies that the endomorphism coalgebra $\text{Hom}_{\mathcal{H}}(X, X)$ of any object $X \in \text{Ob } \mathcal{H}$ in a Hopf groupoid \mathcal{H} forms a Hopf algebra in the classical sense (and similarly in the context of a complete Hopf groupoid), just as the endomorphism set $\text{Mor}_{\mathcal{G}}(X, X)$ of any object $X \in \text{Ob } \mathcal{G}$ in a groupoid \mathcal{G} forms a group. We easily check that:

LEMMA 9.2.6.

- (a) *Let \mathcal{H} be a Hopf groupoid. Suppose that the set of group-like elements $\mathbb{G}(\text{Hom}_{\mathcal{H}}(X, Y))$ is non-empty for every pair $X, Y \in \mathcal{H}$ (equivalently, the groupoid $\mathbb{G}(\mathcal{H})$ is connected). The endomorphism coalgebras $\text{Hom}_{\mathcal{H}}(X, X)^\wedge$ associated to the objects $X \in \mathcal{H}$ in the completion of the Hopf groupoid \mathcal{H} (§9.2.3) are isomorphic to the completion of the Hopf algebras $\text{Hom}_{\mathcal{H}}(X, X)$ (§8.1.1) associated to each object $X \in \mathcal{H}$ individually.*
- (b) *For a connected groupoid $\mathcal{G} \in \text{Grd}$, the endomorphism coalgebras of the objects $X \in \mathcal{G}$ in the complete Hopf groupoid $\mathbb{k}[\mathcal{G}]^\wedge$ associated to \mathcal{G} are isomorphic to the complete group algebras $\mathbb{k}[\text{Mor}_{\mathcal{G}}(X, X)]^\wedge$ associated to each automorphism group $\text{Mor}_{\mathcal{G}}(X, X)$ taken individually.*

PROOF. To check the first assertion (a), we just observe that the filtration of §9.3.3, where we consider all composites of composable homomorphisms in \mathcal{H} , agrees with the filtration of §8.1.1 for the Hopf algebra $\text{Hom}_{\mathcal{H}}(X, X)$, where we only consider composites of endomorphisms of X in \mathcal{H} . The latter is obviously included in the former. The converse inclusion immediately follows from our assumption ensuring that we can insert appropriate invertible elements (recall that the antipode defines an inversion operation on group-like elements) to convert any sequence of composable homomorphisms $X_0 \xrightarrow{f_1} X_1 \xrightarrow{f_2} \cdots \xrightarrow{f_n} X_n$ going from $X_0 = X$ to $X_n = X$ into a sequence of endomorphisms of X .

The second assertion of the lemma is a corollary of the first one. \square

9.2.7. *The category of Malcev complete groupoids.* We define the category of Malcev complete groupoids as the image of the category of complete Hopf groupoids under the functor $\mathbb{G} : \widehat{\mathcal{H}opf\mathcal{G}rd} \rightarrow \mathcal{G}rd$. We also adopt the notation $\widehat{\mathcal{G}rd}$ for this category, so that $\widehat{\mathcal{G}rd} = \mathbb{G}(\widehat{\mathcal{H}opf\mathcal{G}rd})$, and we say that a groupoid \mathcal{G} is Malcev complete when we have $\mathcal{G} = \mathbb{G}(\mathcal{H})$, for some $\mathcal{H} \in \widehat{\mathcal{H}opf\mathcal{G}rd}$, so that $\mathcal{G} \in \widehat{\mathcal{G}rd}$.

We define the Malcev completion of a groupoid by $\hat{\mathcal{G}} = \mathbb{G}\mathbb{k}[\mathcal{G}]^\wedge$ where we consider the complete Hopf groupoid and group-like element functors of §9.2.4.

The observation of Lemma 9.2.6 has the following consequence, which parallels the result of Proposition 8.1.6 Proposition 8.2.1 for Malcev complete groups:

PROPOSITION 9.2.8.

- (a) *The functor $\mathbb{G} : \widehat{\mathcal{H}opf\mathcal{G}rd} \rightarrow \mathcal{G}rd$ induces an injective map on morphism sets*

$$\text{Mor}_{\widehat{\mathcal{H}opf\mathcal{G}rd}}(\mathcal{A}, \mathcal{B}) \hookrightarrow \text{Mor}_{\mathcal{G}rd}(\mathbb{G}(\mathcal{A}), \mathbb{G}(\mathcal{B})),$$

for all $\mathcal{A}, \mathcal{B} \in \widehat{\mathcal{H}opf\mathcal{G}rd}$, and hence, is faithful.

- (b) *If \mathcal{G} is a connected groupoid, then any groupoid morphism $\phi : \mathcal{G} \rightarrow \mathcal{H}$ towards a Malcev complete groupoid $\mathcal{H} = \hat{\mathcal{H}}$ admits a unique factorization*

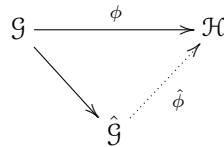

such that $\hat{\phi}$ belongs to the category of Malcev complete groupoids.

PROOF. These assertions follow from the same arguments as the results of Proposition 8.1.6 and Proposition 8.2.1. □

Lemma 9.2.6 also readily implies:

PROPOSITION 9.2.9. *The automorphism group of an object $X \in \mathcal{G}$ in the Malcev completion $\hat{\mathcal{G}}$ of a connected groupoid \mathcal{G} is identified with the Malcev completion (in the classical sense) of the group of automorphisms of X in \mathcal{G} .* □

9.3. Symmetric monoidal structures and operads

We now check that Malcev completion process of the previous section defines a symmetric monoidal functor on groupoids and, as a consequence, induces a functor on operads in groupoids. We actually prove that the adjunction $\mathbb{k}[-]^\wedge : \mathcal{G}rd \rightleftarrows \widehat{\mathcal{H}opf\mathcal{G}rd} : \mathbb{G}$, which we use in our construction of the Malcev completion, is symmetric monoidal in the sense of §2.3.3.

In a preliminary step, we explain the definition of a symmetric monoidal structure on (complete) Hopf groupoids. The idea is to combine the (cartesian) symmetric monoidal structures of categories with the symmetric monoidal structure of (complete) counitary cocommutative coalgebras.

9.3.1. *Symmetric monoidal structures on Hopf categories and Hopf groupoids.* In §5.2.1, we equip the category of categories with the symmetric monoidal structure defined by the cartesian product of categories. In §2.0.3, we observe that the tensor product defines the cartesian product in the category of counitary cocommutative coalgebras.

To Hopf categories \mathcal{G} and \mathcal{H} , we associate the Hopf category $\mathcal{G} \otimes \mathcal{H}$ with the cartesian product $\mathbf{Ob}(\mathcal{G} \otimes \mathcal{H}) = \mathbf{Ob} \mathcal{G} \times \mathbf{Ob} \mathcal{H}$ as object set, and the coalgebra tensor products $\mathbf{Hom}_{\mathcal{G} \otimes \mathcal{H}}((X, Y), (Z, T)) = \mathbf{Hom}_{\mathcal{G}}(X, Z) \otimes \mathbf{Hom}_{\mathcal{H}}(Y, T)$ as hom-coalgebras. These tensor products inherit identity morphisms and composition products from the hom-coalgebras of \mathcal{G} and \mathcal{H} so that $\mathcal{G} \otimes \mathcal{H}$ forms a Hopf category. We moreover have natural functors $\mathcal{G} \xleftarrow{p} \mathcal{G} \otimes \mathcal{H} \xrightarrow{q} \mathcal{H}$ given by the natural projections $\mathbf{Ob} \mathcal{G} \xleftarrow{p} \mathbf{Ob} \mathcal{G} \times \mathbf{Ob} \mathcal{H} \xrightarrow{q} \mathbf{Ob} \mathcal{H}$ on object sets, and yielded by the tensor products with augmentation morphisms $\mathbf{Hom}_{\mathcal{G}}(X, Z) \xleftarrow{\epsilon \otimes id} \mathbf{Hom}_{\mathcal{G}}(X, Z) \otimes \mathbf{Hom}_{\mathcal{H}}(Y, T) \xrightarrow{id \otimes \epsilon} \mathbf{Hom}_{\mathcal{H}}(Y, T)$ on hom-coalgebras (see §2.0.3). This Hopf category $\mathcal{G} \otimes \mathcal{H}$ actually represents the cartesian product of \mathcal{G} and \mathcal{H} in the category of Hopf categories (this assertion follows from our parallel interpretation of the tensor product of counitary cocommutative coalgebras in §2.0.3).

We can replace the plain tensor product by the completed one in order to define an analogous tensor product construction $\hat{\mathcal{G}} \hat{\otimes} \hat{\mathcal{H}}$ for complete Hopf categories. We readily see that the complete Hopf category $\hat{\mathcal{G}} \hat{\otimes} \hat{\mathcal{H}}$ obtained by this operation represents the cartesian product of $\hat{\mathcal{G}}$ and $\hat{\mathcal{H}}$ in the category of complete Hopf categories too.

In §5.2.1, we observe that the cartesian product of groupoids $\mathcal{G} \times \mathcal{H}$, formed in the category of small categories, defines a groupoid and represents the cartesian product of \mathcal{G} and \mathcal{H} in the category of groupoids as well. In the context of Hopf categories, we can similarly prove that the tensor product of Hopf groupoids $\mathcal{G} \otimes \mathcal{H}$ forms a Hopf groupoid and represents the cartesian product of \mathcal{G} and \mathcal{H} in the category of Hopf groupoids, and we have the same statement for the completed tensor product of complete Hopf groupoids.

The existence of these symmetric monoidal structures enables us to give a sense to the notion of an operad in Hopf groupoids and in complete Hopf groupoids. We have the following result:

PROPOSITION 9.3.2.

- (a) *The functors $\mathbb{k}[-]^\wedge : \mathcal{G}rd \rightarrow \widehat{\mathcal{H}opf \mathcal{G}rd}$ and $\mathbb{G} : \widehat{\mathcal{H}opf \mathcal{G}rd} \rightarrow \mathcal{G}rd$, between groupoids and complete Hopf groupoids, are symmetric monoidal, as well as the adjunction relation between them.*
- (b) *These functors can also be applied to operads arity-wise in order to yield functors on operad categories*

$$\mathbb{k}[-]^\wedge : \mathcal{G}rd \mathcal{O}p \rightleftarrows \widehat{\mathcal{H}opf \mathcal{G}rd} \mathcal{O}p : \mathbb{G}$$

and we still have an adjunction relation at this level.

PROOF. The functor $\mathbb{G} : \widehat{\mathcal{H}opf \mathcal{G}rd} \rightarrow \mathcal{G}rd$, defining a right-adjoint of $\mathbb{k}[-]^\wedge : \mathcal{G}rd \rightarrow \widehat{\mathcal{H}opf \mathcal{G}rd}$, preserves terminal objects and cartesian products and is therefore symmetric monoidal since we observed that the (complete) tensor product of (complete) Hopf groupoids represent the cartesian product (as well as the cartesian product of groupoids).

The proof that the functor $\mathbb{k}[-]^\wedge: \mathcal{G}rd \rightarrow \widehat{\mathcal{H}opf}\mathcal{G}rd$ is symmetric monoidal follows from easy verifications. For the trivial one-point set groupoid pt , we obviously have $\mathbb{k}[pt]^\wedge = \mathbb{k}$. For a cartesian product of groupoids $\mathcal{G} \times \mathcal{H}$, we can easily check that the filtration of §9.2.3 satisfies

$$\mathbb{I}^n \mathbb{k}[\mathbf{Mor}_{\mathcal{G} \times \mathcal{H}}((X, Y), (Z, T))] = \sum_{p+q=n} \mathbb{I}^p \mathbb{k}[\mathbf{Mor}_{\mathcal{G}}(X, Z)] \otimes \mathbb{I}^{n-p} \mathbb{k}[\mathbf{Mor}_{\mathcal{H}}(Y, T)]$$

in the coalgebra tensor product

$$\begin{aligned} \mathbb{k}[\mathbf{Mor}_{\mathcal{G} \times \mathcal{H}}((X, Y), (Z, T))] &= \mathbb{k}[\mathbf{Mor}_{\mathcal{G}}(X, Z) \times \mathbf{Mor}_{\mathcal{H}}(Y, T)] \\ &= \mathbb{k}[\mathbf{Mor}_{\mathcal{G}}(X, Z)] \otimes \mathbb{k}[\mathbf{Mor}_{\mathcal{H}}(Y, T)] \end{aligned}$$

The isomorphism $\mathbb{k}[\mathbf{Mor}_{\mathcal{G} \times \mathcal{H}}((X, Y), (Z, T))] \simeq \mathbb{k}[\mathbf{Mor}_{\mathcal{G}}(X, Z)] \otimes \mathbb{k}[\mathbf{Mor}_{\mathcal{H}}(Y, T)]$ is therefore an identity of filtered modules which, as such, induces an isomorphism at the level of completions

$$\mathbb{k}[\mathbf{Mor}_{\mathcal{G} \times \mathcal{H}}((X, Y), (Z, T))]^\wedge \simeq \mathbb{k}[\mathbf{Mor}_{\mathcal{G}}(X, Z)]^\wedge \hat{\otimes} \mathbb{k}[\mathbf{Mor}_{\mathcal{H}}(Y, T)]^\wedge$$

(compare with the proof of Proposition 8.1.7, where we a similar result is established for the Malcev completion of a cartesian product of groups). This verification proves that the natural morphism $\mathbb{k}[\mathcal{G} \times \mathcal{H}]^\wedge \rightarrow \mathbb{k}[\mathcal{G}]^\wedge \hat{\otimes} \mathbb{k}[\mathcal{H}]^\wedge$, induced by the canonical projections $\mathcal{G} \xleftarrow{p} \mathcal{G} \times \mathcal{H} \xrightarrow{q} \mathcal{H}$ (where we use the interpretation of the complete tensor product as a categorical cartesian product), is an iso. The definition of this comparison isomorphism from categorical constructions immediately implies the fulfillment of the unit, associativity and symmetry constraints of §2.3.1 (as usual), and we conclude that $\mathbb{k}[-]^\wedge: \mathcal{G}rd \rightarrow \widehat{\mathcal{H}opf}\mathcal{G}rd$ is symmetric monoidal as asserted.

The proof that the adjunction unit (respectively, augmentation) associated with our functors preserve symmetric monoidal structure reduces to straightforward verifications, and the second assertion of the proposition is a consequence of the general observations of Proposition 2.1.4 and Proposition 2.1.6. \square

This proposition implies:

PROPOSITION 9.3.3. *The Malcev completion functor on groupoids $(-)^^\wedge: \mathcal{G}rd \rightarrow \widehat{\mathcal{G}rd}$ is symmetric monoidal (as a composite of symmetric monoidal functors) and can be applied arity-wise to operads in groupoids in order to yield a Malcev completion functor on operads $(-)^^\wedge: \mathcal{G}rd \mathcal{O}p \rightarrow \widehat{\mathcal{G}rd} \mathcal{O}p$.* \square

To recap the construction, the Malcev completion of an operad in groupoids $P \in \mathcal{G}rd \mathcal{O}p$ is the operad \hat{P} formed by the collection $\hat{P}(r)$, where we consider the Malcev completion of each groupoid $P(r)$. We also have $P = \mathbb{G} \mathbb{k}[P]^\wedge$, where $\mathbb{k}[P]^\wedge$ is the operad in complete Hopf groupoids defined by the completion of the Hopf groupoid $\mathbb{k}[P(r)]$ associated to each $P(r) \in \mathcal{G}rd$, and $\mathbb{G}(-)$ refers to the arity-wise application of the group-like element functor of complete Hopf groupoids.

Recall that in the situation of Proposition 9.3.2(a), the functors $\mathbb{k}[-]^\wedge: \mathcal{G}rd \mathcal{O}p \rightarrow \widehat{\mathcal{H}opf}\mathcal{G}rd \mathcal{O}p$ and $\mathbb{G}: \widehat{\mathcal{H}opf}\mathcal{G}rd \mathcal{O}p \rightarrow \mathcal{G}rd \mathcal{O}p$, preserves unitary extensions of operads (see Proposition 2.1.4), and as a byproduct, so does the composite functors $(-)^^\wedge = \mathbb{G} \mathbb{k}[-]^\wedge$. In the notation of §3.2, we have the identity $(P_+)^^\wedge = (\hat{P})_+$ for any unitary operad in groupoids P_+ .

The Definition of the Grothendieck-Teichmüller Group

We have several notions of Grothendieck-Teichmüller groups. We mostly deal with a pro-unipotent group $GT^1(\mathbb{k})$, defined over any characteristic zero field \mathbb{k} , and which, for us, occurs as a group of automorphisms associated to the parenthesized braid operad of §6. We just have to deal with a Malcev completion of the operad of parenthesized braids in order to get this pro-unipotent Grothendieck-Teichmüller group because the automorphism group of the uncompleted operad of parenthesized braids is trivial.

The pro-unipotent Grothendieck-Teichmüller group $GT^1(\mathbb{k})$ has a graded counterpart $GRT^1(\mathbb{k})$, which we interpret as a group of automorphisms associated to another operad related to little 2-discs, the operad of parenthesized chord diagrams. These groups $GT^1(\mathbb{k})$ and $GRT^1(\mathbb{k})$ are isomorphic, with isomorphisms arising from the set of Drinfeld's associators $Ass^1(\mathbb{k})$, which we interpret as isomorphisms between the parenthesized braid and the chord diagram operad.

The main purpose of this chapter is to explain the definition of the pro-unipotent Grothendieck-Teichmüller group, of the graded Grothendieck-Teichmüller group, and of the torsor of Drinfeld's associators from the operadic viewpoint. We address the definition of the pro-unipotent Grothendieck-Teichmüller group first (§10.1). We give the definition of the operad of chord diagrams and of the torsor of Drinfeld's associators in second (§10.2), and we provide a brief survey of the definition of the graded Grothendieck-Teichmüller group afterwards (§10.3). We work with a fixed coefficient field \mathbb{k} , of characteristic zero, and we address all definitions in this setting.

To conclude this chapter, we survey the definition of the Knizhnik-Zamolodchikov associator, the first instance of associator which was constructed by Drinfeld in [48] from the work of Knizhnik-Zamolodchikov in conformal field theory [99]. We devote §10.4 to this subject.

The second instance of an associator effectively constructed in the literature is the Alekseev-Torossian associator, whose definition, given in articles of Alekseev-Torossian [5] and Ševera-Willwacher [153], arose from Kontsevich's approach of the formality of the little discs operad [104]. The definition of this associator will be explained in the second volume, when we study rational models of the little discs operads.

10.1. The prounipotent Grothendieck-Teichmüller group

The pro-unipotent Grothendieck-Teichmüller group $GT^1(\mathbb{k})$, which we consider in this work, has formally been defined by Drinfeld in [48] as a group of power series satisfying certain equations in the Malcev completion of the pure braid groups.

Drinfeld motivated his definition by explaining that any element in this group $\phi \in GT^1(\mathbb{k})$ could be regarded as a universal transformation acting on (the completion of) braided monoidal categories.

The goal of this section is to revisit Drinfeld's approach and to explain that the group $GT^1(\mathbb{k})$ can be interpreted as a group of automorphisms associated to the Malcev completion of the operad of parenthesized braids of §6. We start with this operadic definition and prove the equivalence with Drinfeld's original definition afterwards.

10.1.1. *The Grothendieck-Teichmüller group as a group of operad automorphisms.* Recall that the operad of parenthesized braids, defined in §6.2, is an operad in groupoids PaB , whose object sets form a free operad on one non-symmetric generator (the magma operad in the terminology of §6.2) and whose morphisms are depicted as braids with contact points on the center of a diadic decomposition of the horizontal axis. We consider the Malcev completion of this operad \widehat{PaB} , and the associated unitary operad \widehat{PaB}_+ . The underlying object operad of the completed operad \widehat{PaB} is also the magma operad by definition of our Malcev completion process for operads in groupoids (see §9). Recall that we use the notation Ω for the magma operad. We accordingly have $\mathbf{Ob} \widehat{PaB} = \mathbf{Ob} PaB = \Omega$

We define the Grothendieck-Teichmüller group $GT^1(\mathbb{k})$ as the group formed by the automorphisms

$$\phi : \widehat{PaB}_+ \xrightarrow{\cong} \widehat{PaB}_+$$

of the unitary operad in Malcev complete groupoids \widehat{PaB}_+ so that:

- (a) each component $\phi(r) : \widehat{PaB}(r) \rightarrow \widehat{PaB}(r)$ of our morphism is given by the identity mapping at the level of the object set $\mathbf{Ob} \widehat{PaB}(r) = \Omega(r)$;
- (b) and the component $\phi(2) : \widehat{PaB}(2) \rightarrow \widehat{PaB}(2)$ also fixes the braiding τ in the morphism set $\mathbf{Mor}_{\widehat{PaB}(2)}(\mu(x_1, x_2), \mu(x_2, x_1))$.

We can drop the constraint (b) from our definition and consider a group $GT(\mathbb{k})$ formed by all automorphisms of the operad \widehat{PaB}_+ which are the identity at the object level. The image of the braiding under a morphism $\phi : \widehat{PaB}_+ \rightarrow \widehat{PaB}_+$ has an expression the form $\phi(\tau) = \tau^\lambda$, for a formal exponent $\lambda \in \mathbb{k}$. We necessarily have $\lambda \in \mathbb{k}^\times$ if we assume that ϕ is an iso, and the mapping $\nu : \phi \mapsto \lambda$ defines a group morphism $\nu : GT(\mathbb{k}) \rightarrow \mathbb{k}^\times$ of which kernel defines the group $GT^1(\mathbb{k})$. We do not use the full group $GT(\mathbb{k})$ further in this book. Just mention that ν is split surjective (this result, established in [48, §5], is a consequence of the existence of associators, which we address in §10.2 and in §10.4).

10.1.2. *The explicit construction of elements in the Grothendieck-Teichmüller group.* By definition of the category of Malcev complete groupoids, a morphism $\phi : \widehat{PaB}_+ \rightarrow \widehat{PaB}_+$ is equivalent to a morphism of operads in groupoids $\phi : PaB_+ \rightarrow \widehat{PaB}_+$, where we now consider the plain version of the parenthesized braid operad PaB_+ . By Theorem 6.2.4, such a morphism is fully determined by giving the image of:

- the object $\mu \in \mathbf{Ob} PaB(2)$,
- the associator $\alpha \in \mathbf{Mor}_{PaB(3)}(\mu(\mu(x_1, x_2), x_3), \mu(x_1, \mu(x_2, x_3)))$,
- and the braiding $\tau \in \mathbf{Mor}_{PaB(2)}(\mu(x_1, x_2), \mu(x_1, x_2))$.

In the general statement of Theorem 6.2.4, we also consider a unit object e in arity 0. In our present setting, and more generally when we deal with unitary

operads, the image of the unit term is just fixed by the assumption that the groupoid $\widehat{PaB}_+(0)$ reduces to the one-point set pt . Since we assume $\phi(\mu) = \mu$ and $\phi(\tau) = \tau$ in the definition of the Grothendieck-Teichmüller group $GT^1(\mathbb{k})$, our morphism $\phi : PaB_+ \rightarrow \widehat{PaB}_+$ can be determined by giving a single morphism $a(x_1, x_2, x_3) = \phi(\alpha) \in \text{Mor}_{\widehat{PaB}}(\mu(\mu(x_1, x_2), x_3), \mu(x_1, \mu(x_2, x_3)))$ in the arity 3 component of the Malcev completion of the parenthesized braid operad \widehat{PaB} .

We go back to the completion process in order to figure out the explicit definition of this element $a(x_1, x_2, x_3)$ such that $a(x_1, x_2, x_3) = \phi(\alpha)$. We have $\text{Mor}_{PaB(3)}(\mu(\mu(x_1, x_2), x_3), \mu(x_1, \mu(x_2, x_3))) \simeq P_3$, where P_3 denotes the pure braid group on 3 strands, and as a consequence:

$$\text{Mor}_{\widehat{PaB}}(\mu(\mu(x_1, x_2), x_3), \mu(x_1, \mu(x_2, x_3))) \simeq \hat{P}_3.$$

Our element $a(x_1, x_2, x_3)$ is therefore determined by an element in the Malcev completion of the pure braid group P_3 .

The group of pure braid groups on 3 strands P_3 is generated by the elements

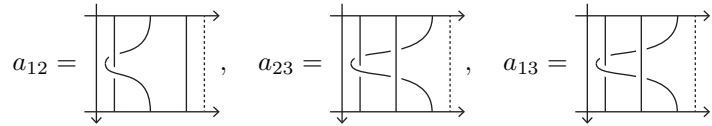

and is also isomorphic to the cartesian product of a central cyclic subgroup $\langle c \rangle$, generated by the following element

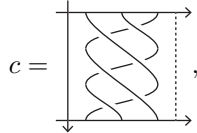

with the free group generated by a_{12} and a_{23} (see for instance [96, §1.3], or the subsequent paragraph §10.2.2 where we give more comprehensive recollections on the presentation of pure braid groups). We actually have $c = a_{12}a_{23}a_{13}$.

Our element $a(x_1, x_2, x_3) \in \hat{P}_3$ consequently splits as a product $a = c^\lambda \cdot F(a_{12}, a_{23})$, for some formal exponent $\lambda \in \mathbb{Q}$ of the central element c , and where $F(a_{12}, a_{23})$ is an element in the Malcev completion of the free group generated by the pure braids a_{12} and a_{23} . The unit relation $a(x_1, e, x_2) = id_{\mu(x_1, x_2)}$, in the correspondence of Theorem 6.2.4, implies the relation $\partial_2(c)^\lambda \cdot F(1, 1) = \partial_2(c)^\lambda = 1$ in \hat{P}_2 , where $\partial_2(c)$ denotes the result of the omission of the second strand in c , and since $\partial_2(c) = \tau^2 \neq 1$, we obtain $\lambda = 0$. Hence, the expression of an element $a = a(x_1, x_2, x_3)$ which corresponds to a well-defined morphism of unitary operads on PaB_+ necessarily reduces to the factor $F = F(a_{12}, a_{23})$ in the Malcev completion of the free group $F(a_{12}, a_{23})$.

We record the outcome of the discussion of this paragraph in a proposition:

PROPOSITION 10.1.3. *A morphism of unitary operads $\phi : PaB_+ \rightarrow \widehat{PaB}_+$ which fixes the generating object of the parenthesized braid operad $\mu = \mu(x_1, x_2) \in \text{Ob } PaB(2)$ and the braiding $\tau \in \text{Mor}_{PaB(2)}(\mu(x_1, x_2), \mu(x_2, x_1))$ is uniquely determined by an elements in the Malcev completion of the free group on two generators*

$$F(x, y) \in \hat{F}(x, y),$$

$$\begin{aligned}
 & F \left(\left(\begin{array}{c} \downarrow \\ \text{Diagram 1} \\ \downarrow \end{array} \right), \left(\begin{array}{c} \downarrow \\ \text{Diagram 2} \\ \downarrow \end{array} \right) \right) \cdot F \left(\left(\begin{array}{c} \downarrow \\ \text{Diagram 3} \\ \downarrow \end{array} \right), \left(\begin{array}{c} \downarrow \\ \text{Diagram 4} \\ \downarrow \end{array} \right) \right) \cdot F \left(\left(\begin{array}{c} \downarrow \\ \text{Diagram 5} \\ \downarrow \end{array} \right), \left(\begin{array}{c} \downarrow \\ \text{Diagram 6} \\ \downarrow \end{array} \right) \right) \\
 &= F \left(\left(\begin{array}{c} \downarrow \\ \text{Diagram 7} \\ \downarrow \end{array} \right), \left(\begin{array}{c} \downarrow \\ \text{Diagram 8} \\ \downarrow \end{array} \right) \right) \cdot F \left(\left(\begin{array}{c} \downarrow \\ \text{Diagram 9} \\ \downarrow \end{array} \right), \left(\begin{array}{c} \downarrow \\ \text{Diagram 10} \\ \downarrow \end{array} \right) \right)
 \end{aligned}$$

FIGURE 10.1. The pentagon constraints for the Malcev group element $F = F(x, y)$ associated to an element of the Grothendieck-Teichmüller group $GT^1(\mathbb{k})$. The relation holds in the Malcev completion of the braid group \hat{P}_4 . The factors of this relation are obtained by applying F , which we regard as an element of the Malcev completion of free group on two generators (x, y) , to the braids $\beta \in P_4$ represented in the picture.

so that we have the formula

$$\phi(\alpha) = \underbrace{\left(\begin{array}{c} \downarrow \\ \text{Diagram 11} \\ \downarrow \end{array} \right)}_{=\alpha} \cdot F \left(\underbrace{\left(\begin{array}{c} \downarrow \\ \text{Diagram 12} \\ \downarrow \end{array} \right), \left(\begin{array}{c} \downarrow \\ \text{Diagram 13} \\ \downarrow \end{array} \right)}_{=F(a_{12}, a_{23})} \right)$$

in the morphism set $\text{Mor}_{\widehat{\text{PaB}}(3)}(\mu(\mu(x_1, x_2), x_3), \mu(x_1, \mu(x_2, x_3)))$ of the parenthesized braid operad $\widehat{\text{PaB}}$. □

To complete this proposition, we write down the coherence constraints of Theorem 6.2.4 for the definition of operad morphisms $\phi : \text{PaB}_+ \rightarrow \widehat{\text{PaB}}_+$ in terms of the associated Malcev group element $F = F(a_{12}, a_{23})$. We obtain the following proposition:

PROPOSITION 10.1.4. *The assignment*

$$\phi(\mu) = \mu, \quad \phi(\tau) = \tau, \quad \phi(\alpha) = \alpha \cdot F(a_{12}, a_{23})$$

in Proposition 10.1.3 determines a well-defined morphism of unitary operads

$$\phi : \text{PaB}_+ \rightarrow \widehat{\text{PaB}}_+$$

if and only if our Malcev group element $F = F(x, y) \in \hat{\mathbb{F}}(x, y)$ satisfies:

- (a) the unit relations $F(x, 1) = 1 = F(1, x)$,
- (b) the involution relation $F(x, y) \cdot F(y, x) = 1$,
- (c) the hexagon equation $F(x, y) \cdot F(z, x) \cdot F(y, z) = 1$, where (x, y, z) is any triple of variables such that $z \cdot y \cdot x = 1$,
- (d) and the pentagon relation of Figure 10.1.

PROOF. We determine the expression of the unit, pentagon and hexagon constraints of Theorem 6.2.4(b-c) for the braiding operator $c = \tau$ and an associator of the form $a = \alpha \cdot F(a_{12}, a_{23})$. The reduction of the unit constraints of the theorem

to $F(x, 1) = 1 = F(1, x)$ is immediate. The equivalence between the pentagon constraint, expressed by the commutation of the diagram of Figure 6.1, and the equation of Figure 10.1 is immediate too (we just expand the expression of our element in the general relation of that figure).

The hexagon relations of the theorem, expressed by the commutation of the diagram of Figure 6.6, read:

$$\begin{aligned} m(1, c) \cdot a \cdot m(c, 1) &= a \cdot c(1, m) \cdot a, \\ m(c, 1) \cdot a^{-1} \cdot m(1, c) &= a^{-1} \cdot c(m, 1) \cdot a^{-1}. \end{aligned}$$

These equations are equivalent to

$$\begin{aligned} a &= (m(1, c)^{-1} a \cdot m(1, c)) \cdot (m(c, 1) \cdot a \cdot m(c, 1)^{-1}) \\ (m(1, c)^{-1} \cdot a^{-1} \cdot m(1, c)) &= (c(m, 1)^{-1} \cdot a^{-1} \cdot c(m, 1)) \cdot a^{-1} \end{aligned}$$

In our case $a = \alpha \cdot F(a_{12}, a_{23})$, we have the relation $g^{-1} \cdot F(x, y) \cdot g = F(g^{-1} x g, g^{-1} y g)$ and we see that

$$\begin{aligned} m(c, 1) \cdot a_{12} \cdot m(c, 1)^{-1} &= a_{12}, & m(c, 1) \cdot a_{23} \cdot m(c, 1)^{-1} &= a_{13}, \\ c(m, 1)^{-1} \cdot a_{12} \cdot c(m, 1) &= a_{13}, & c(m, 1)^{-1} \cdot a_{23} \cdot c(m, 1) &= a_{12}, \\ m(1, c)^{-1} \cdot a_{12} \cdot m(1, c) &= a_{13}, & m(1, c)^{-1} \cdot a_{23} \cdot m(1, c) &= a_{23}. \end{aligned}$$

(Draw the pictures corresponding to these conjugation relations.) Hence, the hexagon relations are equivalent to the combined identities

$$\begin{aligned} &\begin{cases} F(a_{12}, a_{23}) = F(a_{13}, a_{23}) \cdot F(a_{12}, a_{13}), \\ F(a_{13}, a_{23})^{-1} = F(a_{13}, a_{12})^{-1} \cdot F(a_{12}, a_{23})^{-1}, \end{cases} \\ \Leftrightarrow &\begin{cases} F(a_{12}, a_{13}) = F(a_{13}, a_{23})^{-1} \cdot F(a_{12}, a_{23}), \\ F(a_{13}, a_{12})^{-1} = F(a_{13}, a_{23})^{-1} \cdot F(a_{12}, a_{23}) \end{cases} \end{aligned}$$

in the group \hat{P}_3 .

The elements $x = a_{12}$ and $y = a_{13}$ generate a free group in P_3 (like a_{12} and a_{23}), and the already mentioned relation $c = a_{12} a_{23} a_{13}$ implies that a_{23} agrees with the product $z = x^{-1} y^{-1}$ up to a central element c which we can factor from any formal expression in the group \hat{P}_3 . These observations imply that our equations are equivalent to the system of relations

$$F(x, y) = F(y, x)^{-1} \quad \text{and} \quad F(x, y) \cdot F(z, x) \cdot F(y, z) = 1$$

given in our statement, and this result completes the verification of our assertions. \square

In the discussion of §10.1.2, we already recalled that the morphisms $\phi : PaB_+ \rightarrow \widehat{PaB}_+$ in Proposition 10.1.4 are equivalent to morphisms defined on the Malcev completion of the parenthesized braid operad. Let $\phi : \widehat{PaB}_+ \rightarrow \widehat{PaB}_+$ and $\psi : \widehat{PaB}_+ \rightarrow \widehat{PaB}_+$ be such morphisms, associated to the Malcev group elements $F(x, y) \in \hat{\mathbb{F}}(x, y)$ and $G(x, y) \in \hat{\mathbb{F}}(x, y)$ under the correspondence of Proposition 10.1.3-10.1.4.

We have the following easy observation:

PROPOSITION 10.1.5. *The Malcev group element $(F \circ G)(x, y) \in \widehat{\mathbb{F}}(x, y)$ associated to the composite morphism $\phi \circ \psi : \widehat{\mathcal{PaB}}_+ \rightarrow \widehat{\mathcal{PaB}}_+$ can be determined by the formula*

$$(F \circ G)(x, y) = F(x, y) \cdot G(x, y^F),$$

where we set $y^F = F(x, y)^{-1} \cdot y \cdot F(x, y)$.

PROOF. Exercise: go back to the arguments of Theorem 6.2.4 in order to determine the image of the element $\psi(\alpha) = \alpha \cdot G(a_{12}, a_{23})$ under the morphism ϕ determined by the Malcev group element $F(x, y)$. \square

We get the following final result:

THEOREM 10.1.6 (Equivalence between the operadic approach and the Drinfeld definition [48, §4]). *The Grothendieck-Teichmüller group $GT^1(\mathbb{k})$ is isomorphic to the group formed by the Malcev group elements $F(x, y) \in \widehat{\mathbb{F}}(x, y)$, which satisfy the relations of Proposition 10.1.4, and are invertible with respect to the composition operation of Proposition 10.1.5.* \square

10.1.7. *The pro-unipotent structure of the Grothendieck-Teichmüller group.* The Grothendieck-Teichmüller group $GT^1(\mathbb{k})$ is equipped with a natural filtration by normal subgroups $F_m GT^1(\mathbb{k})$ such that $GT^1(\mathbb{k}) = \lim_m GT^1(\mathbb{k})/F_m GT^1(\mathbb{k})$, and each quotient $GT^1(\mathbb{k})/F_m GT^1(\mathbb{k})$ is unipotent in the classical sense of algebraic group theory (see for instance [30]). We therefore say that $GT^1(\mathbb{k})$ is a pro-unipotent version of the Grothendieck-Teichmüller group, as opposed to the profinite version which occurs in Grothendieck's program (see our overview in the concluding part of this volume).

We refer to [48, §5] for a description of the Lie algebra \mathfrak{gt}^1 associated with this pro-algebraic group structure on $GT^1(\mathbb{k})$. This Lie algebra \mathfrak{gt}^1 is also equipped with a filtration such that $\mathfrak{gt}^1 = \lim_m \mathfrak{gt}^1/F_m \mathfrak{gt}^1$.

In the next section, we define a graded version of the Grothendieck-Teichmüller group $GRT^1(\mathbb{k})$, which is also pro-algebraic. The Lie algebra associated with this group, denoted by \mathfrak{grt}^1 , is equipped with a weight grading such that $\mathfrak{grt}^1 = \mathbf{E}^0 \mathfrak{gt}^1$, and this relationship motivates the name (as well as the notation) given to this group (see [48, §5]).

10.2. The operad of chord diagrams and associators

We now address the definition of the torsor of Drinfeld's associators. In the introduction of the chapter, we only mention the torsor $Ass^1(\mathbb{k})$, but we have a torsor $Ass^\mu(\mathbb{k})$ associated to each parameter $\mu \in \mathbb{k}^\times$ and we recall the general definition.

We first define an operad in weight graded Lie algebras, the Drinfeld-Kohno operad, which intuitively represents an infinitesimal approximation of the operad of colored braids of §5.2. We proved in §8 that any Malcev complete group \hat{G} is associated to a complete Lie algebra $\hat{\mathfrak{g}}$ so that $\hat{G} = \mathbb{G}\mathbb{k}[\hat{G}]^\wedge = \mathbb{G}\hat{U}(\hat{\mathfrak{g}})$. We moreover have an identity $\mathbf{E}^0 \hat{\mathfrak{g}} = \mathbf{E}^0 \hat{G}$, where $\mathbf{E}^0 \hat{G}$ is a weight graded Lie algebra defined by the sub-quotients of a natural filtration on \hat{G} . The weight graded Lie algebras $\mathfrak{p}(r)$ defining the components of the Drinfeld-Kohno operad $\mathfrak{p} = \{\mathfrak{p}(r)\}$ are identified with the weight graded Lie algebras $\mathbf{E}^0 \hat{P}_r$ associated to the Malcev completion of the pure braid groups $G = P_r$. Recall that P_r represents the automorphism

group of any object in the r th component of the operad of colored braids $\text{CoB}(r)$. The definition of the operad structure on the Drinfeld-Kohno operad reflects the structure of this operad.

In a second step, we study an operad in complete Hopf algebras formed by the completion (with respect to the weight grading) of the enveloping algebras of the Drinfeld-Kohno Lie algebras $\hat{\mathfrak{p}}(r)$. We regard this operad in complete Hopf algebras as an operad in complete Hopf groupoids which has the one-point set as object set in each arity. We use the notation \widehat{CD} for the image of this operad under the group-like element functor (see §9.3), and we adopt the name of chord diagram operad to refer to this operad in the category of Malcev complete groupoids. This terminology is motivated by a correspondence between the monomials in the enveloping algebra of the Drinfeld-Kohno Lie algebras and certain chord diagrams occurring in the definition of a universal Vassiliev invariant.

We have by definition $\text{Mor } \widehat{CD}(r) = \mathbb{G}\hat{\mathfrak{p}}(r) = \{e^\xi | \xi \in \hat{\mathfrak{p}}(r)\}$, where we take the completion of a weight graded Lie algebra $\mathfrak{p}(r)$ such that $\mathfrak{p}(r) = \mathbb{E}^0 \hat{P}_r$. The main purpose of this section is to check the existence of categorical equivalences of operads $\phi : \widehat{PaB} \rightarrow \widehat{CD}$ which realizes this identity of weight graded objects at the morphism level. We deduce from Theorem 6.2.4 that the set of these operad morphisms is in bijection with a set of associators in the chord diagram operad. We precisely check that this set of associators is equivalent to the notion of associator introduced by Drinfeld in [48], and as such, is not empty for any coefficient field of characteristic zero \mathbb{k} .

To start with, we explain the definition of the Drinfeld-Kohno Lie algebras $\mathfrak{p}(r)$, $r \in \mathbb{N}$.

10.2.1. *The Drinfeld-Kohno Lie algebras.* The r th Drinfeld-Kohno Lie algebra $\mathfrak{p}(r)$ is defined by a presentation by generators and relations

$$\mathfrak{p}(r) = \mathbb{L}(t_{ij} | 1 \leq i \neq j \leq r) / \langle [t_{ij}, t_{kl}], [t_{ij}, t_{ik} + t_{kl}] \rangle$$

where:

- (a) a generator t_{ij} is associated to each pair $\{i \neq j\} \subset \{1, \dots, r\}$,
- (b) and the generating relations consist of the commutation relations

$$[t_{ij}, t_{kl}] = 0,$$

which hold for all quadruples $\{i \neq j \neq k \neq l\} \subset \{1, \dots, r\}$, together with relations

$$[t_{ij}, t_{ik} + t_{kj}] = 0,$$

usually referred to as the Yang-Baxter relations, which hold for all triples $\{i \neq j \neq k\} \subset \{1, \dots, r\}$.

In these expressions, we assume $t_{ij} = t_{ji}$ for each pair $\{i, j\} \subset \{1, \dots, r\}$.

The generating relations (b) are homogeneous with respect to the natural weight grading of free Lie algebras. The Lie algebras $\mathfrak{p}(r)$ accordingly inherit a weight grading where the generating elements t_{ij} are homogeneous of weight 1. We explicitly have $\mathfrak{p}(r)_m = \mathbb{L}_m / \mathbb{L}_m \cap \langle [t_{ij}, t_{kl}], [t_{ij}, t_{ik} + t_{kl}] \rangle$, where we set \mathbb{L}_m for the homogeneous component of weight m in the free Lie algebra $\mathbb{L} = \mathbb{L}(t_{ij} | 1 \leq i \neq j \leq r)$.

10.2.2. *The connection with the presentation of pure braid groups.* In §10.1.2, we recall the definition of the generating elements a_{ij} of the pure braid group on 3 strands P_3 . In the general case, we consider an obvious extension of this definition, with an element $a_{ij} \in P_r$, associated to each pair $\{i < j\} \subset \{1 < \dots < r\}$, given by the following picture:

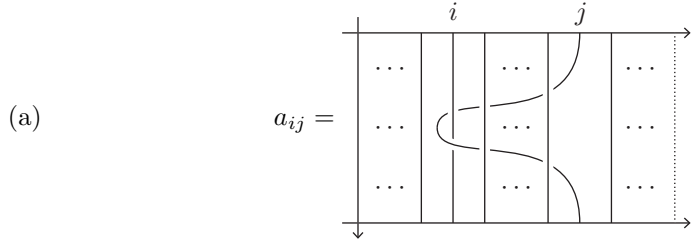

Note that the ordering of the pair $i < j$ is significant in this definition since we do not get the same braid when we swap the positions of the strands (i, j) . The pure braid group P_r has a presentation with these elements as generators, and whose generating relations read:

$$(b) \quad a_{kl}^{-1} a_{ij} a_{kl} = \begin{cases} a_{ij}, & \text{for } k < l < i < j \text{ or } i < k < l < j, \\ a_{kj} a_{ij} a_{kj}^{-1}, & \text{for } k < l = i < j, \\ (a_{ij} a_{lj}) a_{ij} (a_{ij} a_{lj})^{-1}, & \text{for } k = i < l < j, \\ (a_{kj} a_{lj} a_{kj}^{-1} a_{lj}^{-1}) a_{ij} (a_{kj} a_{lj} a_{kj}^{-1} a_{lj}^{-1})^{-1}, & \text{for } k < i < l < j. \end{cases}$$

Just recall that the pure braid group P_r can be defined as the fundamental group of the configuration space of r points in the open disc $F(\mathbb{D}^2, r)$. The above presentation can be established by induction, by using the homotopy exact sequence associated to the fibration $f : F(\mathbb{D}^2, r) \rightarrow F(\mathbb{D}^2, r - 1)$ which forgets about the last point of a configuration. In the proof of Proposition 5.0.1, we already observed that the fiber of this map is a disc with $r - 1$ punctures $\mathbb{D}^2 \setminus \{z_1^0, \dots, z_{r-1}^0\}$, so that our homotopy exact exact reduces to a short exact sequence of fundamental groups

$$1 \rightarrow \pi_1(\mathbb{D}^2 \setminus \{z_1^0, \dots, z_{r-1}^0\}) \rightarrow \underbrace{\pi_1 F(\mathbb{D}^2, r)}_{=P_r} \rightarrow \underbrace{\pi_1 F(\mathbb{D}^2, r - 1)}_{=P_{r-1}} \rightarrow 1.$$

The elements $a_{ir}, i = 1, \dots, r - 1$, in our presentation are given by the standard generators of the fundamental group of this punctured disc $\mathbb{D}^2 \setminus \{z_1^0, \dots, z_{r-1}^0\}$. We refer to [24] for details.

We use the following theorem:

THEOREM 10.2.3 (T. Kohno [102]). *We have a Hopf algebra isomorphism*

$$v : \cup \mathfrak{p}(r) \xrightarrow{\cong} \mathbf{E}^0 \mathbb{k}[P_r]$$

defined on generating elements by the mapping

$$v(t_{ij}) = \overline{[a_{ij}] - 1}, \quad \text{for } i < j,$$

where we use the notation $\overline{[a_{ij}] - 1}$ for the class of the difference $[a_{ij}] - 1 \in \mathbb{k}[P_r]$ in the homogeneous component of weight 1 of the weight graded algebra $\mathbf{E}^0 \mathbb{k}[P_r] = \bigoplus_s \mathbb{l}^s \mathbb{k}[P_r] / \mathbb{l}^{s+1} \mathbb{k}[P_r]$.

EXPLANATIONS AND REFERENCES. The difference $\overline{[a_{ij}] - 1}$ defines a primitive element in the weight graded Hopf algebra $\mathbf{E}^0 \mathbb{k}[P_r]$ because we have

$$\Delta(\overline{[a_{ij}] - 1}) = (\overline{[a_{ij}] - 1}) \otimes 1 + 1 \otimes (\overline{[a_{ij}] - 1}) + \underbrace{(\overline{[a_{ij}] - 1}) \otimes (\overline{[a_{ij}] - 1})}_{\equiv 0}$$

by definition of the filtration on a tensor product. We can moreover readily deduce, from the relations (b) of §10.2.2, that our mapping cancels the defining relations of the Drinfeld-Kohno Lie algebra (go back to the relations establish in the proof of Proposition 8.2.4 in order to perform this computation). We therefore have a well defined morphism of weight graded Hopf algebras $v : \mathbb{U}(\mathfrak{p}(r)) \rightarrow \mathbf{E}^0 \mathbb{k}[P_r]$ such that $v(t_{ij}) = \overline{[a_{ij}] - 1}$, for all $i < j$.

The difficulty is to check that this mapping is an iso. This result is established by methods of rational homotopy in the cited paper [102]. In a more elementary approach, one can rely on the short exact sequence of fundamental groups of §10.2.2 to establish that the sub-quotients of the derived series of the group P_r are isomorphic to the homogeneous components of the Drinfeld-Kohno Lie algebra (see [180]), and we can use this observation (together with general statements of §7.3 and §8) to define a morphism of Lie algebras $\mathbb{P}(\mathbf{E}^0 \mathbb{k}[P_r]) = \mathbf{E}^0(\hat{P}_r) \rightarrow \mathfrak{p}(r)$ yielding an inverse of our map $v : \mathbb{U} \mathfrak{p}(r) \rightarrow \mathbf{E}^0 \mathbb{k}[P_r]$ at the Hopf algebra level. \square

By Proposition 8.2.4, the claim of Theorem 10.2.3 is also equivalent to the definition of an isomorphism $v : \mathfrak{p}(r) \xrightarrow{\cong} \mathbf{E}^0 \hat{P}_r$ between the Drinfeld-Kohno Lie algebra $\mathfrak{p}(r)$ and the weight graded Lie algebra associated to the Malcev completion of the pure braid group P_r . This iso maps the generator t_{ij} of the Drinfeld-Kohno Lie algebra to the class of the element $a_{ij} \in P_r$ in the subquotient $\mathbf{E}^0 \hat{P}_r$. In applications of this section, we use this equivalent form of the result of Theorem 10.2.3.

10.2.4. *The algebras of chord diagrams.* The enveloping algebra of the Drinfeld-Kohno Lie algebra $\mathfrak{p}(r)$ is identified with the associative algebras defined by the presentation:

$$\mathbb{U} \mathfrak{p}(r) = \mathbb{T}(t_{ij} | 1 \leq i \neq j \leq r) / \langle [t_{ij}, t_{kl}], [t_{ij}, t_{ik} + t_{kj}] \rangle,$$

where we consider the same relations as in the Lie algebra case, but the bracket now refers to the commutator $[a, b] = ab - ba$.

The associative algebra given by this presentation is also called the algebra of chord diagrams. This expression refers to a representation of the monomials $t_{i_1 j_1} \cdots t_{i_m j_m}$ by chord diagrams on r strands. The diagrams corresponding to such a monomial is obtained by drawing a chord between the strand i_k and the strand j_k , for each factor $t_{i_k j_k}$, so that the composition ordering of the monomial, read from right to left, corresponds to a downwards orientation of the diagram. For instance, we have:

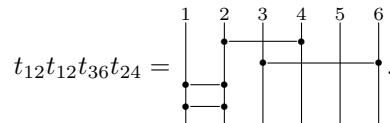

In this chord diagram representation, the commutation relation reads

$$\begin{array}{c} i & j \\ | & | \\ \bullet & \bullet \\ | & | \\ i & j \end{array} \begin{array}{c} k & l \\ | & | \\ \bullet & \bullet \\ | & | \\ k & l \end{array} - \begin{array}{c} i & j \\ | & | \\ \bullet & \bullet \\ | & | \\ i & j \end{array} \begin{array}{c} k & l \\ | & | \\ \bullet & \bullet \\ | & | \\ k & l \end{array} = 0,$$

and the Yang-Baxter relation is equivalent to the identity:

$$\begin{array}{c} i & j & k \\ | & | & | \\ \hline | & | & | \\ \hline | & | & | \\ | & | & | \end{array} + \begin{array}{c} i & j & k \\ | & | & | \\ \hline | & | & | \\ \hline | & | & | \\ | & | & | \end{array} - \begin{array}{c} i & j & k \\ | & | & | \\ \hline | & | & | \\ \hline | & | & | \\ | & | & | \end{array} - \begin{array}{c} i & j & k \\ | & | & | \\ \hline | & | & | \\ \hline | & | & | \\ | & | & | \end{array} = 0.$$

This latter equation is also called the four term relation (the $4T$ relation for short) in the literature on Vassiliev’s invariants.

10.2.5. *The operad structure on the Drinfeld-Kohno Lie algebras.* In §§7.2.20-7.2.23, we introduce the direct sum of Lie algebras as the tensor product operation of a symmetric monoidal structure, which we use to define the notion of an operad in the category of Lie algebras.

We provide the collection of Lie algebras $\mathfrak{p}(r)$, $r \in \mathbb{N}$, with such an operad structure:

- (a) the action of a permutation $w \in \Sigma_r$ on the Lie algebra $\mathfrak{p}(r)$ is defined on generating elements by the formula

$$w \cdot t_{ij} = t_{w(i)w(j)}$$

for all pairs $\{i, j\} \subset \{1, \dots, r\}$,

- (b) the operadic unit $\eta : 0 \rightarrow \mathfrak{p}(1)$ is naturally given by the zero morphism (which is also an isomorphism since we trivially have $\mathfrak{p}(1) = 0$),
- (c) the partial composition products are the Lie algebra morphisms

$$\circ_k : \mathfrak{p}(m) \oplus \mathfrak{p}(n) \rightarrow \mathfrak{p}(m + n - 1)$$

such that

$$t_{ij} \circ_k 0 = \begin{cases} t_{i+n-1j+n-1}, & \text{if } k < i < j, \\ t_{ij+n-1} + \dots + t_{i+n-1j+n-1}, & \text{if } k = i < j, \\ t_{ij+n-1}, & \text{if } i < k < j, \\ t_{ij} + \dots + t_{ij+n-1}, & \text{if } i < k = j, \\ t_{ij}, & \text{if } i < j < k, \end{cases}$$

and

$$0 \circ_k t_{pq} = t_{p+k-1q+k-1} \quad \text{for all values of } k = 1, \dots, m,$$

where we use the notation $x \circ_k y$ for the image of an element (x, y) under this Lie algebra map \circ_k .

Recall that the Lie algebra morphisms $\phi : \mathfrak{g} \oplus \mathfrak{h} \rightarrow \mathfrak{m}$ are equivalent to pairs of Lie algebra morphisms $(u : \mathfrak{g} \rightarrow \mathfrak{m}, v : \mathfrak{h} \rightarrow \mathfrak{m})$ such that $[u(\mathfrak{g}), v(\mathfrak{h})] = 0$. In the definition of (c), we implicitly assume that our maps give rise to such well-defined Lie algebra morphisms on the direct sum $\mathfrak{p}(m) \oplus \mathfrak{p}(n)$. This assertion follows from straightforward verifications involving the commutation and the Yang-Baxter relations.

The verification of the operad axioms in the Lie algebras $\mathfrak{p}(r)$ is immediate from our definition of the structure morphisms on generating elements. We refer to this operad, formed by the collection of the Drinfeld-Kohno Lie algebras $\mathfrak{p} = \{\mathfrak{p}(r)\}$, as the Drinfeld-Kohno operad.

10.2.6. *The operad structure on chord diagrams.* By Proposition 7.2.23, we have an iso $\mathbb{U}(\mathfrak{g}) \otimes \mathbb{U}(\mathfrak{h}) = \mathbb{U}(\mathfrak{g} \oplus \mathfrak{h})$ so that the enveloping algebra functor defines a symmetric monoidal functor from Lie algebras to Hopf algebras. This result implies, according to the general statement of Proposition 2.1.4, that the collection of enveloping algebras $\mathbb{U}\mathfrak{p} = (\mathbb{U}\mathfrak{p}(n))$ forms an operad in the category of Hopf algebras. In short:

- each Hopf algebra $\mathbb{U}\mathfrak{p}(r)$ inherits an action of the symmetric group from the Lie algebra $\mathfrak{p}(r)$ by functoriality of the enveloping algebra mapping;
- we moreover have $\mathfrak{p}(1) = 0 \Rightarrow \mathbb{U}\mathfrak{p}(1) = \mathbb{k}$ so that our collection $\mathbb{U}\mathfrak{p}$ has an obvious operadic unit;
- and we consider the Hopf algebra morphisms

$$\mathbb{U}(\mathfrak{p}(m)) \otimes \mathbb{U}(\mathfrak{p}(n)) \xrightarrow{\cong} \mathbb{U}(\mathfrak{p}(m) \oplus \mathfrak{p}(n)) \xrightarrow{\circ_k} \mathbb{U}(\mathfrak{p}(m+n-1)),$$

induced by the Lie algebra morphism of §10.2.5(c) to define the partial composition products of our operad $\mathbb{U}\mathfrak{p}$.

In the chord diagram representation, the k th partial composition product of monomials in the enveloping algebra $\mathbb{U}\mathfrak{p}(m+n-1)$ can be identified with a natural cabling operation where a chord diagram on n strands u is plugged in the k th strand of an input chord diagram v . The composite of these chord diagrams $u \circ_k v$ is the sum of all diagrams obtained by attaching the strings joining the k th strand of u to a strand in v . To give a simple example, we have the formula

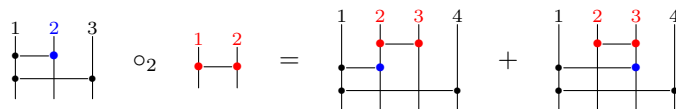

in $\mathbb{U}\mathfrak{p}(4)$.

10.2.7. *The unitary extension of the Drinfeld-Kohno operad.* In §§10.2.5-10.2.6, we are not precise about the arity 0 component of our operads. By convention, we assume that we deal with a non-unitary operad when we use the notation \mathfrak{p} . But the definition of §10.2.5 has an obvious extension in the unitary setting. Hence, we also have a unitary operad in the category of Lie algebras, defining a unitary extension of our operad \mathfrak{p} , and which we denote by \mathfrak{p}_+ (with the usual $+$ mark of unitary operads). Recall that we have to adapt the concepts of §§3.2-3.3 when we work within a symmetric monoidal category, like the category of Lie algebras, of which tensor product does not preserve colimits (see §§1.1.19-1.1.20). To be explicit, when we deal with such a situation, we simply drop our consideration of arity 0 terms in the definition of non-unitary operads instead of assuming that such terms are given by the initial object of the ambient category. In fact, since the initial object (the zero object) 0 is the tensor product unit in the category of Lie algebras, we have $\mathfrak{p}_+(0) = 0$ for the unitary operad \mathfrak{p}_+ , and not the converse.

The definition of the partial composition operations with this arity zero term are given by a formal extension of the definition of §10.2.5. The restriction morphisms $\partial_k : \mathfrak{p}(r) \rightarrow \mathfrak{p}(r-1)$, $k = 1, \dots, r$, equivalent to these partial composition operations,

are given on generating elements by:

$$\partial_k(t_{ij}) = \begin{cases} t_{i-1j-1}, & \text{if } k < i < j, \\ 0, & \text{if } k = i < j, \\ t_{ij-1}, & \text{if } i < k < j, \\ 0, & \text{if } i < k = j, \\ t_{ij}, & \text{if } i < j < k. \end{cases}$$

We adopt similar conventions for the enveloping algebra operad associated to the Drinfeld-Kohno operad in Lie algebras. We then have $\mathbb{U}\mathfrak{p}_+(0) = \mathbb{k}$, the ground ring, which also represents the zero object of the category of Hopf algebras. We can identify the restriction morphisms $\partial_k : \mathbb{U}\mathfrak{p}(r) \rightarrow \mathbb{U}\mathfrak{p}(r-1)$, $k = 1, \dots, r$, with the operation which consists in withdrawing the k th strand in the chord diagram representation of our monomials. The image of a chord diagram under this operation is zero as soon as a chord is attached to the k th strand of our diagram.

10.2.8. *Completions and the operad of chord diagrams.* We can regard the Hopf algebras of §10.2.4 as the hom-objects of a collection of Hopf groupoids $\mathcal{H}(r)$ such that $\mathbf{Ob}\mathcal{H}(r) = pt$ and $\mathbf{Hom}_{\mathcal{H}(r)}(pt, pt) = \mathbb{U}\mathfrak{p}(r)$ for each $r > 0$. We have an operad structure on this collection of Hopf groupoids defined by the construction of §10.2.8 at the hom-object level. We apply the completion process of §9.2 to get an operad in complete Hopf groupoids $\hat{\mathcal{H}}$ from this operad \mathcal{H} .

The filtration used to defined this completion is given, on the hom-object $\mathbf{Hom}_{\mathcal{H}(r)}(pt, pt)$, by the powers of the augmentation ideal of the enveloping algebra $\mathbb{U}(\mathfrak{p}(r))$. In the presentation of §10.2.4, we readily see that the s th layer of this filtration $\mathbb{U}^s \mathbb{U}(\mathfrak{p}(r))$ is identified with the module spanned by monomials $t_{i_1j_1} \cdots t_{i_mj_m}$ of length $m \geq s$. These monomials corresponds to chord diagrams with $m \geq s$ chords in our representation. The completion of the enveloping algebra $\mathbb{U}(\mathfrak{p}(r))$ with respect to this filtration is also identified with the complete enveloping algebra $\hat{\mathbb{U}}(\hat{\mathfrak{p}}(r))$ on the complete Lie algebra $\hat{\mathfrak{p}}(r)$ such that

$$\hat{\mathfrak{p}}(r) = \hat{\mathbb{L}}(t_{ij} | 1 \leq i \neq j \leq r) / \langle [t_{ij}, t_{kl}], [t_{ij}, t_{ik} + t_{kj}] \rangle,$$

for each $r > 0$, where we take the same conventions as in Proposition 8.3.1 for the definition of the free complete Lie algebra $\hat{\mathbb{L}}(t_{ij} | 1 \leq i \neq j \leq r)$. Since the generating relations of the Lie algebra $\mathfrak{p}(r)$ are homogeneous, we have an identity $\hat{\mathfrak{p}}(r) = \prod_{m=1}^{\infty} \mathbb{L}_m / \mathbb{L}_m \cap \langle [t_{ij}, t_{kl}], [t_{ij}, t_{ik} + t_{kj}] \rangle$, where, as in §10.2.1, we set \mathbb{L}_m for the homogeneous component of weight m of the free Lie algebra $\mathbb{L} = \mathbb{L}(t_{ij} | 1 \leq i \neq j \leq r)$. The complete enveloping algebra $\hat{\mathbb{U}}(\hat{\mathfrak{p}}(r))$ similarly satisfies $\hat{\mathbb{U}}(\hat{\mathfrak{p}}(r)) = \hat{\mathbb{T}}(t_{ij} | 1 \leq i \neq j \leq r) / \langle [t_{ij}, t_{kl}], [t_{ij}, t_{ik} + t_{kj}] \rangle$, where we just replace the ordinary tensor algebra of §10.2.4 by the completed one.

We adopt the expression of chord diagram operad, and use the notation \widehat{CD} , for the operad in Malcev complete groupoids such that $\mathbf{Ob}\widehat{CD} = \mathbb{G}(\hat{\mathcal{H}})$, where we apply the group-like element functor of §9.2.4 (see also §9.3). We therefore have $\mathbf{Ob}\widehat{CD}(r) = pt$ and

$$\mathbf{Mor}_{\widehat{CD}(r)}(pt, pt) = \mathbb{G} \underbrace{\hat{\mathbb{T}}(t_{ij} | 1 \leq i \neq j \leq r) / \langle [t_{ij}, t_{kl}], [t_{ij}, t_{ik} + t_{kj}] \rangle}_{=\hat{\mathbb{U}}(\hat{\mathfrak{p}}(r))},$$

for every $r > 0$.

Proposition 8.1.5 (see also Lemma 9.2.9) gives an identity between the morphisms $u \in \text{Mor}_{\widehat{\text{CD}}(r)}(pt, pt)$ and the exponentials e^p such that $p \in \hat{\mathfrak{p}}(r)$. The defining structure morphisms of this operad are defined by constant maps at the object set level and by the structure morphisms of the Drinfeld-Kohno Lie operad at the morphism set level.

The chord diagram operad has also an obvious unitary extension $\widehat{\text{CD}}_+$ defined by considering the unitary extension of the Drinfeld-Kohno operad at the morphism level.

10.2.9. *Operad morphisms and associators in the chord diagram operad.* We consider the set of morphisms of unitary operads in Malcev complete groupoids

$$\phi : \widehat{\text{PaB}}_+ \rightarrow \widehat{\text{CD}}_+$$

which are bijective at the morphism set level, and hence, define a categorical equivalence from the Malcev completion of the operad of parenthesized braids $\widehat{\text{PaB}}_+$ towards the Malcev complete operad of chord diagrams $\widehat{\text{CD}}_+$.

By Proposition 9.2.8, any such morphism of operads in the category of Malcev complete groupoids $\phi : \widehat{\text{PaB}}_+ \rightarrow \widehat{\text{CD}}_+$ occurs as the unique extension, to the completed operad $\widehat{\text{PaB}}_+$, of a morphism of operads in groupoids $\phi : \text{PaB}_+ \rightarrow \widehat{\text{CD}}_+$, where we consider the basic operad of parenthesized braids PaB_+ and we forget about the Malcev structure of the operad of chord diagrams. By Theorem 6.2.4, the construction of such a morphism $\phi : \text{PaB}_+ \rightarrow \widehat{\text{CD}}_+$ reduces to the definition of a product operation $m = m(x_1, x_2) = \phi(\mu) \in \text{Ob } \widehat{\text{CD}}(2)$ in the chord diagram operad $\widehat{\text{CD}}$, of a braiding $c = c(x_1, x_2) = \phi(\tau) \in \text{Mor } \widehat{\text{CD}}(2)$, and of an associator $a = a(x_1, x_2, x_3) = \phi(\alpha) \in \text{Mor } \widehat{\text{CD}}(3)$. The unit object e , which is also considered in the general statement of Theorem 6.2.4, is again fixed by the assumption that the groupoid $\widehat{\text{CD}}_+(0)$ reduces to the one-point set pt . We have no choice for the product too $m = \phi(\mu) \in \text{Ob } \widehat{\text{CD}}(2)$ since we have $\text{Ob } \widehat{\text{CD}}(r) = pt$ for all $r > 0$ by definition of the chord diagram operad.

In arity 2, we trivially have $\hat{\mathfrak{p}}(2) = \mathbb{k}t_{12}$ so that the braiding $c = c(x_1, x_2) \in \text{Mor}_{\widehat{\text{CD}}(2)}(pt, pt)$ is given by an exponential

$$(a) \quad c(x_1, x_2) = \exp(\mu t_{12}/2) \in \mathbb{G} \hat{\mathbb{U}}(\hat{\mathfrak{p}}(2)),$$

for some $\mu \in \mathbb{k}$. In the case of a categorical equivalence, we assume that our morphism ϕ induces a bijection of morphism sets $\text{Mor}_{\widehat{\text{PaB}}(2)}(pt, pt) \xrightarrow{\cong} \text{Mor}_{\widehat{\text{CD}}(2)}(pt, pt)$, and this requirement implies $\mu \in \mathbb{k}^\times$.

In arity 3, the Lie algebra $\hat{\mathfrak{p}}(3)$ splits as a direct sum $\hat{\mathfrak{p}}(3) = \mathbb{k}c \oplus \hat{\mathbb{L}}(t_{12}, t_{23})$, where $\mathbb{k}c$ is a central Lie subalgebra, spanned by the element $c = t_{12} + t_{23} + t_{13}$, and we consider the free complete Lie algebra generated by the Drinfeld-Kohno elements t_{12} and t_{23} . We therefore have $a(x_1, x_2, x_3) = e^{\lambda c} \cdot \Phi(t_{12}, t_{23})$, where $\lambda \in \mathbb{k}$ and $\Phi(t_{12}, t_{23})$ is a group like element in the enveloping algebra of the free complete Lie algebra $\hat{\mathbb{L}}(t_{12}, t_{23})$. We immediately deduce from the unit identity $a(x_1, e, x_3) = 0$ that the central factor $e^{\lambda c}$ is trivial in $a(x_1, x_2, x_3)$. Thus we finally obtain an expression of the form:

$$(b) \quad a(x_1, x_2, x_3) = \Phi(t_{12}, t_{23}) \in \mathbb{G} \hat{\mathbb{U}}\hat{\mathbb{L}}(t_{12}, t_{23})$$

for the associator $a = a(x_1, x_2, x_3) \in \text{Mor } \widehat{\text{CD}}(3)$. We record the outcome of this discussion in a proposition:

PROPOSITION 10.2.10. *A morphism of unitary operads $\phi : PaB_+ \rightarrow \widehat{CD}_+$, satisfying*

$$\phi(\tau) = \exp(\mu t_{12}/2) \in \text{Mor}_{\widehat{CD}(2)}(pt, pt), \quad \mu \in \mathbb{k}^\times,$$

for the braiding $\tau \in \text{Mor } PaB(2)$, is uniquely determined by a group-like power series

$$\Phi(t_{12}, t_{23}) \in \mathbb{G}\widehat{T}(t_{12}, t_{23}) = \mathbb{G}\widehat{U}\widehat{L}(t_{12}, t_{23})$$

so that we have:

$$\phi(\alpha) = \Phi(t_{12}, t_{23})$$

in the morphism set $\text{Mor}_{\widehat{CD}(3)}(pt, pt)$. \square

To complete this proposition, we write down the coherence constraints of Theorem 6.2.4 for the definition of operad morphisms $\phi : PaB_+ \rightarrow \widehat{CD}_+$ in terms of the corresponding associator $\Phi = \Phi(t_{12}, t_{23})$. We obtain the following proposition:

PROPOSITION 10.2.11. *The assignment*

$$\phi(\mu) = pt, \quad \phi(\tau) = \exp(\mu t_{12}/2), \quad \phi(\alpha) = \Phi(t_{12}, t_{23}),$$

in Proposition 10.2.10, determines a well-defined morphism of unitary operads

$$\phi : PaB_+ \rightarrow \widehat{CD}_+$$

if and only if our power series $\Phi(t_{12}, t_{23})$ satisfies:

- (a) *the unit relations $\Phi(x, 0) = 1 = \Phi(0, x)$,*
- (b) *the involution relation $\Phi(x, y) \cdot \Phi(y, x) = 1$,*
- (c) *the hexagon equation $e^{\mu x/2} \cdot \Phi(z, x) \cdot e^{\mu z/2} \cdot \Phi(y, z) \cdot e^{\mu y/2} \cdot \Phi(x, y) = 1$,*
where (x, y, z) is any triple of variables such that $z + y + x = 0$.
- (d) *and the pentagon equation*

$$\begin{aligned} & \Phi(t_{12}, t_{23} + t_{34}) \cdot \Phi(t_{13} + t_{23}, t_{34}) \\ &= \Phi(t_{23}, t_{34}) \cdot \Phi(t_{12} + t_{13}, t_{24} + t_{34}) \cdot \Phi(t_{12}, t_{23}) \end{aligned}$$

in $\widehat{U}(\widehat{\mathfrak{p}}(4))$.

PROOF. We determine the expression of the unit, pentagon and hexagon constraints of Theorem 6.2.4 for the braiding $\phi(\tau) = \exp(\mu t_{12}/2)$ and an element of the form $\phi(\alpha) = \Phi(t_{12}, t_{23})$ in \widehat{CD} . The equivalence between the pentagon constraint of Figure 6.1 and the equation of Figure 10.1 is immediate (we just expand the expression of our element in the general relation of Figure 6.1). The reduction of the unit constraints of Theorem 6.2.4 to $\Phi(x, 0) = 1 = \Phi(0, x)$ is immediate too.

The hexagon equations read:

$$\begin{aligned} e^{\mu t_{13}/2} \cdot \Phi(t_{12}, t_{13}) \cdot e^{\mu t_{12}/2} &= \Phi(t_{23}, t_{13}) \cdot e^{\mu(t_{12}+t_{13})/2} \cdot \Phi(t_{12}, t_{23}), \\ e^{\mu t_{13}/2} \cdot \Phi(t_{13}, t_{23})^{-1} \cdot e^{\mu t_{23}/2} &= \Phi(t_{13}, t_{12})^{-1} \cdot e^{\mu(t_{13}+t_{23})/2} \cdot \Phi(t_{12}, t_{23})^{-1}. \end{aligned}$$

In the first equation, we set $x = t_{13}$, $y = t_{23}$. We then have $t_{12} = z + c$, where we set $z = -x - y$ and $c = t_{12} + t_{23} + t_{13}$ denotes the central element of $\mathfrak{p}(3)$ as in §10.2.9. The unit relations $\Phi(x, 0) = 1 = \Phi(0, x)$ implies that the Lie power series $P(x, y) = \log \Phi(x, y) \in \mathbb{L}(x, y)$ such that $\Phi(x, y) = \exp(P(x, y))$ has no component in weight 1, and we consequently have $\Phi(t_{12}, -) = \Phi(z, -)$, and $\Phi(-, t_{12}) = \Phi(-, z)$,

since c is central $[c, -] = 0$. We can also collect the factors $e^{\mu c/2}$ in our equation. The first hexagon relation is therefore equivalent to the equation:

$$\begin{aligned} e^{\mu x/2} \cdot \Phi(z, x) \cdot e^{\mu z/2} &= \Phi(y, x) \cdot e^{-\mu y/2} \cdot \Phi(z, y) \\ \Leftrightarrow \Phi(y, x) &= e^{\mu x/2} \cdot \Phi(z, x) \cdot e^{\mu z/2} \cdot \Phi(z, y)^{-1} \cdot e^{\mu y/2} \end{aligned}$$

The second hexagon relation, where we set $x = t_{12}$ and $y = t_{23}$, so that $t_{13} = z + c$ for $z = -x - y$, is similarly equivalent to the equation

$$\begin{aligned} e^{\mu z/2} \cdot \Phi(z, y)^{-1} \cdot e^{\mu y/2} &= \Phi(z, x)^{-1} \cdot e^{-\mu x/2} \cdot \Phi(x, y)^{-1} \\ \Leftrightarrow \Phi(x, y)^{-1} &= e^{\mu x/2} \cdot \Phi(z, x) \cdot e^{\mu z/2} \cdot \Phi(z, y)^{-1} \cdot e^{\mu y/2}. \end{aligned}$$

These equations are clearly equivalent to the combination of relations

$$\Phi(y, x) = \Phi(x, y)^{-1} \quad \text{and} \quad e^{\mu x/2} \cdot \Phi(z, x) \cdot e^{\mu z/2} \cdot \Phi(y, z) \cdot e^{\mu y/2} \cdot \Phi(x, y) = 1,$$

given in our statement, and this result completes the verification of our assertions. \square

10.2.12. *Remark.* By Proposition 8.1.5, the group like elements $\Phi(t_{12}, t_{23})$ considered in Proposition 10.2.10, satisfy $\Phi(t_{12}, t_{23}) = \exp P(t_{12}, t_{23})$ for a Lie power series $P(t_{12}, t_{23}) = \alpha t_{12} + \beta t_{23} + \gamma [t_{12}, t_{23}] + \cdots \in \hat{\mathbb{L}}(t_{12}, t_{23})$. In the proof of our statement, we have already observed that the unit relations $\Phi(x, 0) = \Phi(0, x) = 1$ imply $\alpha = \beta = 0$. By a theorem of Furusho (see [64]), any element $\Phi(t_{12}, t_{23}) \in \mathbb{G} \hat{\mathbb{T}}(t_{12}, t_{23})$ satisfying the pentagon equation (d) of Proposition 10.2.11 also satisfies the hexagon equation (c) for a parameter $\mu \in \mathbb{k}$ determined by the coefficient $\gamma \in \mathbb{k}$.

In the discussion of §10.2.9, we already recalled that the morphisms $\phi : PaB_+ \rightarrow \widehat{CD}_+$ in Proposition 10.2.11 are equivalent to morphisms defined on the Malcev completion of the parenthesized braid operad $\phi : \widehat{PaB}_+ \rightarrow \widehat{CD}_+$. In §10.1, we used the same correspondence for the study of the automorphisms of the Malcev completion of the parenthesized braid operad. In the associator case, we can establish the following result:

PROPOSITION 10.2.13. *The morphisms $\phi : \widehat{PaB}_+ \rightarrow \widehat{CD}_+$ arising from the construction of Proposition 10.2.11 induce bijections on morphisms sets (and hence, are categorical equivalences of operads in groupoids in the sense of §5.2.2), as soon as we assume $\mu \in \mathbb{k}^\times$.*

PROOF. To establish this proposition, we use the identity $\mathbf{Mor}_{\widehat{PaB}(r)}(p, p) = \hat{P}_r$, which holds for any parenthesized word $p \in \Omega(r)$, and the isomorphism $v : \mathfrak{p}(r) \xrightarrow{\cong} \mathbf{E}^0 \hat{P}_r$ between the Drinfeld-Kohno Lie algebra $\mathfrak{p}(r)$ and the weight graded Lie algebra associated to the Malcev completion of the pure braid group P_r . Recall that this iso associates the element $\bar{a}_{ij} \in \mathbf{E}^0 \hat{P}_r$ to the generator t_{ij} of the Drinfeld-Kohno Lie algebra.

We have by definition $\mathbf{Mor}_{\widehat{CD}(r)}(pt, pt) = \mathbb{G} \hat{\mathbb{U}}(\hat{\mathfrak{p}}(r))$, where we consider the completion of the Lie algebra $\mathfrak{p}(r)$ with respect to the filtration defined by the weight grading. By Proposition 8.1.5, we also have an iso $\mathbf{E}^0 \mathbb{G} \hat{\mathbb{U}}(\hat{\mathfrak{p}}(r)) = \mathbf{E}^0 \hat{\mathfrak{p}}(r) = \mathfrak{p}(r)$, yielded by the exponential mapping.

Since all morphism sets of the groupoid $\widehat{PaB}(r)$ are isomorphic, we can work with the fixed parenthesized word $p = ((\cdots((x_1x_2)x_3)\cdots)x_r)$. Each subgroup of the natural filtration on $\mathbb{G}\widehat{U}(\widehat{p}(r))$ is normal (by the commutator condition of §8.2.2) and each sub-quotient $\mathbb{E}^0\mathbb{G}\widehat{U}(\widehat{p}(r))$ is also abelian. Consequently, we have $g^{-1} \cdot e^{\lambda t_{ij}} \cdot g = e^{\lambda t_{ij}/2}$ in $\mathbb{E}^0\mathbb{G}\widehat{U}(\widehat{p}(r))$, for any $\lambda \in \mathbb{k}$, and this exponential also corresponds to the element λt_{ij} in the Drinfeld-Kohno Lie algebra. The image of the pure braid generator a_{ij} in the morphism set $\text{Mor}_{\widehat{PaB}(r)}(p, p)$, can be written as a composite morphism

$$u = g^{-1} \cdot q(x_1, \dots, \tau^2(x_i, x_j), \dots, x_r) \cdot g,$$

where g is a composite of braidings and associators in $PaB(r)$, and q is a parenthesized word on $r - 1$ variables. The image of this composite under our morphism $\phi : \widehat{PaB}_+ \rightarrow \widehat{CD}_+$ reads

$$\phi(u) = \phi(g)^{-1} \cdot e^{\mu t_{ij}} \cdot \phi(g),$$

and according to our recollections, reduce to the exponential $e^{\mu t_{ij}}$ in the sub-quotient.

Hence, our map

$$\underbrace{\text{Mor}_{\widehat{PaB}(r)}(p, p)}_{=\widehat{P}_r} \xrightarrow{\phi} \underbrace{\text{Mor}_{\widehat{CD}(r)}(pt, pt)}_{=\mathbb{G}\widehat{U}(\widehat{p}(r))}$$

reduces to the multiple $\mu \cdot v^{-1}$ of the inverse of the iso v considered in Theorem 10.2.3 on the weight graded Lie algebras $\mathbb{E}^0\widehat{G}$ associated to our groups $\widehat{G} = \widehat{P}_r, \mathbb{G}\widehat{U}(\widehat{p}(r))$. By the limit condition of §8.2.2, we immediately conclude that the map ϕ is bijective at the level of our morphism sets themselves, so that $\phi : \widehat{PaB}_+(r) \rightarrow \widehat{CD}_+(r)$ defines an equivalence of groupoids for each $r \in \mathbb{N}$. \square

We now consider an automorphism of the completed parenthesized braid operad $\psi : \widehat{PaB}_+ \rightarrow \widehat{PaB}_+$, which defines an element in the Grothendieck-Teichmüller group, and we aim to determine the composite $\phi \circ \psi : \widehat{PaB}_+ \rightarrow \widehat{CD}_+$ of this morphism with our categorical equivalence of operads in Malcev complete groupoids $\phi : \widehat{PaB}_+ \rightarrow \widehat{CD}_+$. Let $G(x, y) \in \widehat{\mathbb{F}}(x, y)$ be the Malcev group element associated to $\psi : \widehat{PaB}_+ \rightarrow \widehat{PaB}_+$ under the correspondence of Proposition 10.1.3-10.1.4. We still deal with the power series $\Phi(t_{12}, t_{23}) \in \mathbb{G}\widehat{\mathbb{T}}(t_{12}, t_{23})$, associated to $\phi : \widehat{PaB}_+ \rightarrow \widehat{CD}_+$.

We have the following easy observation:

PROPOSITION 10.2.14. *The composite morphism $\phi \circ \psi : \widehat{PaB}_+ \rightarrow \widehat{CD}_+$ satisfies $\phi \circ \psi(\tau) = \phi(\tau) = \exp(\mu t_{12}/2)$, and the power series $\phi \circ \psi(\alpha) = \Phi^G(t_{12}, t_{23}) \in \mathbb{G}\widehat{\mathbb{T}}(t_{12}, t_{23})$ associated to this composite morphism under the correspondence of Proposition 10.2.10-10.2.11 can be determined by the formula:*

$$\Phi^G(t_{12}, t_{23}) = \Phi(t_{12}, t_{23}) \cdot G(\exp(\mu t_{12}/2), \exp(\mu t_{23}/2)^\Phi),$$

where we set $y^\Phi = \Phi(t_{12}, t_{23})^{-1} \cdot y \cdot \Phi(t_{12}, t_{23})$ for any $y \in \widehat{\mathbb{T}}(t_{12}, t_{23})$.

PROOF. Exercise: go back to the arguments of Theorem 6.2.4 in order to determine the image of the element $\psi(\alpha) = \alpha \cdot G(a_{12}, a_{23})$ under the morphism ϕ determined by our power series $\Phi(t_{12}, t_{23})$. \square

10.2.15. *The explicit definition of the set of Drinfeld’s associators.* We now define the set of Drinfeld’s associators, denoted by $Ass^\mu(\mathbb{k})$, as the set of group-like power series

$$\Phi(t_{12}, t_{23}) \in \mathbb{G}\hat{\mathbb{T}}(t_{12}, t_{23}) = \mathbb{G}\hat{\mathbb{U}}\hat{\mathbb{L}}(t_{12}, t_{23})$$

satisfying the unit, involution, hexagon and pentagon constraints (a-d) of Proposition 10.2.11, for a given parameter $\mu \in \mathbb{k}^\times$. We use the discussion §10.2.9 and the result of Proposition 10.2.11 to identify such a power series with an associator in the chord diagram operad \widehat{CD}_+

$$a(x_1, x_2, x_3) = \Phi(t_{12}, t_{23}) \in \underbrace{\text{Mor}_{\widehat{CD}(3)}(pt, pt)}_{=\mathbb{G}\hat{\mathbb{U}}(\hat{\mathfrak{p}}(3))}$$

where we take the braiding morphism $c(x_1, x_2) = \exp(\mu t_{12}/2)$ to fix a symmetry constraint.

We summarize the result of Proposition-10.2.10-10.2.13 in the following Theorem:

THEOREM 10.2.16 (Equivalence between the operadic approach and the Drinfeld definition [48, §5]). *The categorical equivalences of operads in Malcev complete groupoids*

$$\phi : \widehat{PaB}_+ \rightarrow \widehat{CD}_+$$

satisfying

$$\phi(\tau) = \exp(\mu t_{12}/2),$$

for some parameter $\mu \in \mathbb{k}^\times$, are in bijections with the Drinfeld associators $\Phi(t_{12}, t_{23}) \in Ass^\mu(\mathbb{k})$, so that we have

$$\phi(\alpha) = \Phi(t_{12}, t_{23})$$

in the chord diagram operad \widehat{CD}_+ , where τ (respectively, α) denotes the braiding morphism (respectively, associator) defined within the parenthesized braid operad (see §6.2.3). □

We have the following result:

THEOREM 10.2.17 (V. Drinfeld [48, Proposition 5.3, Proposition 5.8]). *The set of Drinfeld’s associators $Ass^1(\mathbb{k})$ is not empty for every field such that $\mathbb{Q} \subset \mathbb{k}$.*

The cited paper of V. Drinfeld [48] gives a first analytic construction of an associator, in the complex coefficient case $\mathbb{k} = \mathbb{C}$. Drinfeld’s construction relies on the study of the holonomy of a connection, the Knizhnik-Zamolodchikov connection, which was introduced by Knizhnik-Zamolodchikov in the realm of conformal field theory [99]. The papers [5, 153], give another effective construction of an associator by using the holonomy of another connection, usually called the Alekseev-Torossian connection. The definition of this latter connection relies on fiberwise integrations, encoded by a graph complex, of certain differential forms on configuration spaces of points in the plane. This process was introduced by M. Kontsevich in his work on deformation-quantization [104, 105]. We give a brief account of Drinfeld’s associator construction in §10.4. We will survey Kontsevich’s construction of differential forms and give a brief overview of the definition of the Alekseev-Torossian associator later on, in §II.7, when we study the formality of the little discs operads.

The existence of associators with coefficients in any characteristic zero field is established in [48, Proposition 5.3, Proposition 5.8] by two different methods. In the approach of [48, Proposition 5.8] (see also [13, Corollary 4.1]) the idea is to consider the sets $Ass_m^1(\mathbb{k})$ formed by the truncated power series $\Phi_m(t_{12}, t_{23}) \in \widehat{\mathbb{T}}(t_{12}, t_{23}) / \mathbb{T}^{m+1} \widehat{\mathbb{T}}(t_{12}, t_{23})$ which satisfy the constraints attached to an associator modulo error terms of weight $> m$. We then have $Ass^1(\mathbb{k}) = \lim_m Ass_m^1(\mathbb{k})$.

The lifting $\Phi_{m+1} \in Ass_{m+1}^1(\mathbb{k})$ of a residue $\Phi_m \in Ass_m^1(\mathbb{k})$ is determined by affine equations with the element Φ_m as second member. (We refer to the cited articles [13, 48] for details.) The existence of a complex (or real) associator implies that these affine equations have a solution in the field $\mathbb{k} \subset \mathbb{C}$, for any such $\Phi_m \in Ass_m^1(\mathbb{k})$. Hence, we can obtain a whole sequence of truncated power series $\Phi_m(t_{12}, t_{23})$ defining an element $\Phi(t_{12}, t_{23})$ in the limit set $Ass^1(\mathbb{k}) = \lim_m Ass_m^1(\mathbb{k})$.

10.2.18. *The set of associators as a torsor under the Grothendieck-Teichmüller group.* The definition of §10.2.9 readily implies that the group $GT^1(\mathbb{k})$ acts freely and transitively on each set $Ass^\mu(\mathbb{k})$, for any fixed parameter $\mu \in \mathbb{k}^\times$.

In §10.1.7, we mention that the group $GT^1(\mathbb{k})$ decomposes into a limit $GT^1(\mathbb{k}) = \lim_m GT^1(\mathbb{k}) / \mathbb{F}_m GT^1(\mathbb{k})$, where each quotient $GT_m^1(\mathbb{k}) = GT^1(\mathbb{k}) / \mathbb{F}_m GT^1(\mathbb{k})$ is an (algebraic) unipotent group. The just considered quotients $Ass_m^\mu(\mathbb{k})$ are also algebraic varieties and each of them $Ass_m^\mu(\mathbb{k})$ forms a torsor, in the sense of algebraic group theory (see for instance [137, §III.4]), under the group $GT_m^1(\mathbb{k})$. The set of associators $Ass^\mu(\mathbb{k})$ is therefore a pro-torsor under the pro-unipotent group $GT^1(\mathbb{k})$.

In the next section, we explain that the set $Ass^\mu(\mathbb{k})$ inherits an action of the graded Grothendieck-Teichmüller group $GRT^1(\mathbb{k})$ too. Both actions commute and the set $Ass^\mu(\mathbb{k})$ actually forms a pro-bitorsor under the action of the groups $GT^1(\mathbb{k})$ and $GRT^1(\mathbb{k})$.

10.3. The graded Grothendieck-Teichmüller group

The purpose of this section is to outline the definition of the graded Grothendieck-Teichmüller group $GRT^1(\mathbb{k})$. This group has also been introduced by Drinfeld in [48] and we again revisit Drinfeld's original definition by introducing an operadic viewpoint. We do not use the graded Grothendieck-Teichmüller group in our study. We therefore reduce the account of this section to a survey of main definitions, and we just give references for the proof of each statement.

We can apply the pullback construction of §6.1.5 to get a parenthesized version of the chord diagram operad \widehat{PaCD}_+ with the magma as object operad. We explicitly define the graded Grothendieck-Teichmüller group $GRT^1(\mathbb{k})$ by analogy with the pronipotent Grothendieck-Teichmüller group $GT^1(\mathbb{k})$ as a group of automorphisms associated to this operad \widehat{PaCD}_+ . We examine the definition of the operad \widehat{PaCD}_+ first.

In §6, we mention that Bar-Natan uses the name of parenthesized braids and the notation PaB for a concept which differs from our operad of parenthesized braids (see [13]). He actually deals with homogeneous components of the free algebra on one variable associated with this operad (in the linear context). Let us mention that the objects referred to as the parenthesized chord diagrams categories in [13] similarly differ from our categories of parenthesized chord diagrams $\widehat{PaCD}_+(r)$, and

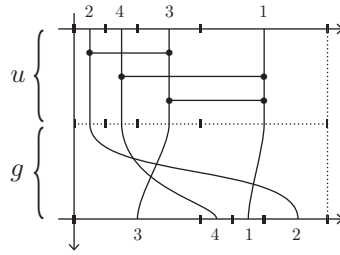

FIGURE 10.2. The picture of a homomorphism in the operad in Hopf groupoids underlying the parenthesized chord diagram operad \widehat{PaCD} .

actually consist of the homogeneous components of the free algebra on one variable associated with this operad.

10.3.1. *The operad of parenthesized chord diagrams.* We consider the obvious morphism of set operads $\omega : \Omega \rightarrow \mathbf{Ob} \widehat{CD}$, defined by the constant map $\Omega(r) \rightarrow \mathbf{Ob} \widehat{CD}(r) = pt$ in each arity r , and which sends the generating element of the magma operad $\mu \in \Omega(2)$ to the element $m = \phi(\mu)$ of the one-point set formed by this object operad $\mathbf{Ob} \widehat{CD}$ in arity $r = 2$. We define the operad of parenthesized chord diagrams by setting $\widehat{PaCD} = \omega^* \widehat{CD}$, where the notation ω^* refers to the pullback process of §6.1.5.

Each groupoid $\widehat{PaCD}(r)$, $r > 0$, satisfies $\mathbf{Ob} \widehat{PaCD}(r) = \Omega(r)$ by construction, and we have $\mathbf{Mor}_{\widehat{PaCD}(r)}(p, q) = \mathbf{Mor}_{\widehat{CD}(r)}(pt, pt) = \mathbb{G} \hat{\mathcal{U}}(\hat{\mathfrak{p}}(r))$ for all $p, q \in \Omega(r)$. The symmetric group actions, the unit, and the composition operations defining the operad structure on this collection of groupoids are, as usual, inherited from the magma operad at the object set level and from the chord diagram operad at the morphism set level (see §6.1.5). The operad of parenthesized chord diagrams has a unitary version (like the parenthesized permutation and the parenthesized braid operads) defined by an obvious unitary extension of our pullback construction.

We have an obvious identity $\widehat{PaCD} = \mathbb{G}(\hat{\mathcal{H}})$, where we consider the completion $\hat{\mathcal{H}}$ of the operad in Hopf groupoids \mathcal{H} such that $\mathbf{Ob} \mathcal{H}(r) = \Omega(r)$ and $\mathbf{Hom}_{\mathcal{H}(r)}(p, q) = \hat{\mathcal{U}}(\hat{\mathfrak{p}}(r))$ for all $p, q \in \Omega(r)$.

We can combine the chord diagram picture of §10.2.4 and the conventions of §6.2.1 to get a graphical representation of the homomorphisms of this operad \mathcal{H} , and of the completed operad $\hat{\mathcal{H}}$ similarly. We basically use that each homomorphism $f \in \mathbf{Hom}_{\mathcal{H}(r)}(p, q)$ has a canonical decomposition $f = g \cdot u$ such that $g \in \mathbf{Hom}_{\mathcal{H}(r)}(p, q)$ is represented by the unit element 1 in the Hopf algebra $\mathbb{U} \mathfrak{p}(r)$, and u is an endomorphism of the object $p \in \Omega(r)$ which captures the enveloping algebra element corresponding to f in $\mathbf{Hom}_{\mathcal{H}(r)}(p, q) = \mathbb{U} \mathfrak{p}(r)$. We represent this factor $u \in \mathbf{Hom}_{\mathcal{H}(r)}(p, p) = \mathbb{U} \mathfrak{p}(r)$ by a chord diagram on r strands arranged on the centers of the diadic decomposition of the interval corresponding to our element $p \in \Omega(r)$. We identify the factor $g \in \mathbf{Hom}_{\mathcal{H}(r)}(p, q)$ of our morphism with a correspondence, marked by lines in our figure, between the centers of the diadic decompositions associated to p and q . Figure 10.2 gives an instance of this representation for a homomorphism $f = g \cdot u \in \mathbf{Hom}_{\mathcal{H}(r)}(\left(\left(\left(x_2 x_4\right) x_3\right) x_1\right), \left(x_3\left(\left(x_4 x_1\right) x_2\right)\right)$.

Fundamental instances of morphisms in the operad of parenthesized chord diagrams $\widehat{\text{PaCD}}$ include the associator

(a) $\alpha =$ 

(whose representation is the same as in the parenthesized braid operad case), the symmetry operator

(b) $\tau =$ 

and the exponential element

(c) $\gamma = \exp \left(\left(\begin{array}{c} \text{Diagram of the exponential element } \gamma \end{array} \right) \right).$

One can prove an analogue of the result of Theorem 6.2.4 for the operad of parenthesized chord diagrams (adapt the arguments of [13, Proposition 4.5, Proposition 4.8] to our formalism).

10.3.2. *The graded Grothendieck-Teichmüller group.* We define the graded Grothendieck-Teichmüller group $GRT^1(\mathbb{Q})$ as the group formed by the automorphisms

$$\phi : \widehat{\text{PaCD}}_+ \xrightarrow{\cong} \widehat{\text{PaCD}}_+$$

of the unitary operad in Malcev complete groupoids $\widehat{\text{PaCD}}_+$ so that:

- (a) each component $\phi(r) : \widehat{\text{PaCD}}(r) \rightarrow \widehat{\text{PaCD}}(r)$ of our morphism is given by the identity mapping at the level of the object set $\text{Ob } \widehat{\text{PaCD}}_+(r) = \Omega_+(r)$;
- (b) and the component $\phi(2) : \widehat{\text{PaCD}}(2) \rightarrow \widehat{\text{PaCD}}(2)$ fixes the symmetry operator τ in the morphism set $\text{Mor}_{\widehat{\text{PaCD}}(2)}(\mu(x_1, x_2), \mu(x_2, x_1))$
- (c) as well as the exponential element $\gamma \in \text{Mor}_{\widehat{\text{PaCD}}(2)}(\mu(x_1, x_2), \mu(x_1, x_2))$ of §10.3.1(c).

As in the case of the prounipotent Grothendieck-Teichmüller group, we can drop the constraint (c) and consider a group $GRT(\mathbb{Q})$ formed by all automorphisms of the operad $\widehat{\text{PaCD}}_+$ which are the identity at the object level and fix the symmetry operator τ . The image of the chord exponential γ under a morphism $\phi : \widehat{\text{PaCD}}_+ \rightarrow \widehat{\text{PaCD}}_+$ has an expression the form $\phi(\gamma) = \gamma^\lambda$, for a formal exponent $\lambda \in \mathbb{k}$. We again see that this exponent necessarily satisfies $\lambda \in \mathbb{k}^\times$ if we assume that ϕ is an iso, and the mapping $\nu : \phi \mapsto \lambda$ defines a group morphism $\nu : GRT(\mathbb{k}) \rightarrow \mathbb{k}^\times$ of which kernel represents the group $GRT^1(\mathbb{k})$.

The result of Proposition 10.1.3 has the following easy analogue:

PROPOSITION 10.3.3. *The operad morphisms $\phi : \widehat{\text{PaCD}}_+ \rightarrow \widehat{\text{PaCD}}_+$ which fix*

- the object $\mu = \mu(x_1, x_2) \in \text{Ob } \widehat{\text{PaCD}}(2)$,
- the braiding $\tau \in \text{Mor}_{\widehat{\text{PaCD}}(2)}(\mu(x_1, x_2), \mu(x_2, x_1))$,
- and the exponential element $\gamma = e^{t^{12}} \in \text{Mor}_{\widehat{\text{PaCD}}(2)}(\mu(x_1, x_2), \mu(x_1, x_2))$,

are uniquely determined by an associated group-like power series

$$\Phi(t_{12}, t_{23}) \in \mathbb{G} \hat{\mathbb{T}}(t_{12}, t_{23}) = \mathbb{G} \hat{\mathbb{U}}\hat{\mathbb{L}}(t_{12}, t_{23})$$

so that we have

$$\phi(\alpha) = \alpha \cdot \Phi(t_{12}, t_{23})$$

in the morphism set $\text{Mor}_{\widehat{\text{PaCD}}(3)}(\mu(\mu(x_1, x_2), x_3), \mu(x_1, \mu(x_2, x_3)))$ of the parenthesized chord diagram operad $\widehat{\text{PaCD}}$. \square

We also have the following statement, which parallels the result of Proposition 10.1.4:

PROPOSITION 10.3.4. *The assignment*

$$\phi(\mu) = \mu, \quad \phi(\tau) = \tau, \quad \phi(\gamma) = \gamma, \quad \phi(\alpha) = \alpha \cdot \Phi(t_{12}, t_{23})$$

in Proposition 10.3.3 determines a well-defined morphism of unitary operads

$$\phi : \widehat{\text{PaCD}}_+ \rightarrow \widehat{\text{PaCD}}_+$$

if and only if our power series $\Phi(t_{12}, t_{23}) \in \mathbb{G} \hat{\mathbb{T}}(t_{12}, t_{23})$ satisfies:

- (a) the unit relations $\Phi(x, 0) = 1 = \Phi(0, x)$,
- (b) the involution relation $\Phi(x, y) \cdot \Phi(y, x) = 1$,
- (c) the hexagon equation $\Phi(z, x) \cdot \Phi(y, z) \cdot \Phi(x, y) = 1$, where (x, y, z) is any triple of variables such that $z + y + x = 0$,
- (d) the semi-classical hexagon equation

$$x + \Phi(x, y)^{-1} \cdot y \cdot \Phi(x, y) + \Phi(x, z)^{-1} \cdot z \cdot \Phi(x, z) = 0,$$

where (x, y, z) is again a triple of variables such that $z + y + x = 0$,

- (e) and the pentagon equation

$$\begin{aligned} &\Phi(t_{12}, t_{23} + t_{34}) \cdot \Phi(t_{13} + t_{23}, t_{34}) \\ &= \Phi(t_{23}, t_{34}) \cdot \Phi(t_{12} + t_{13}, t_{24} + t_{34}) \cdot \Phi(t_{12}, t_{23}) \end{aligned}$$

in $\hat{\mathbb{U}}(\hat{\mathfrak{p}}(4))$.

PROOF. We refer to [13] for the proof of a similar statement, which we can readily adapt in our setting. \square

We have the following extra result, which parallels the statement of Proposition 10.2.13 on Drinfeld’s associators:

PROPOSITION 10.3.5. *The morphisms $\phi : \widehat{\text{PaCD}}_+ \rightarrow \widehat{\text{PaCD}}_+$ arising from the construction of (10.3.4) automatically induce bijections on morphisms sets, and hence, are isomorphisms of operads in groupoids.*

PROOF. We refer to [13] for the proof of a similar statement, which we can again readily adapt in our setting. \square

Let $\phi, \psi : \widehat{\text{PaCD}}_+ \rightarrow \widehat{\text{PaCD}}_+$ be endomorphisms of the operad $\widehat{\text{PaCD}}_+$. Let $\Phi(t_{12}, t_{23}), \Psi(t_{12}, t_{23}) \in \mathbb{G} \hat{\mathbb{F}}(t_{12}, t_{23})$ be the group-like power series which are associated to these morphisms under the correspondence of Proposition 10.3.3-10.3.4. Proposition 10.1.5, about the composition of morphisms in the pro-unipotent Grothendieck-Teichmüller group, has the following analogue:

PROPOSITION 10.3.6. *The group-like element $(\Phi \circ \Psi)(t_{12}, t_{23}) \in \mathbb{G}\widehat{\mathbb{F}}(t_{12}, t_{23})$ associated to the composite morphism $\phi \circ \psi : \widehat{PaCD}_+ \rightarrow \widehat{PaCD}_+$ under to the result of Proposition 10.3.4, can be determined by the formula*

$$(\Phi \circ \Psi)(t_{12}, t_{23}) = \Phi(t_{12}, t_{23}) \cdot \Psi(t_{12}, t_{23}^\Phi),$$

where we set $u^\Phi = \Phi(t_{12}, t_{23})^{-1} \cdot u \cdot \Phi(t_{12}, t_{23})$.

PROOF. We consider the operad in complete Hopf groupoids $\widehat{\mathcal{H}}$ of §10.3.1 and the morphism of this operad equivalent to our morphisms $\phi, \psi : \widehat{PaCD}_+ \rightarrow \widehat{PaCD}_+$. The chord diagrams $t_{12}, t_{23} \in \widehat{\mathcal{U}}(\widehat{\mathfrak{p}}(3))$ in the expression $\psi(\alpha) = \alpha \cdot \Psi(t_{12}, t_{23})$ represents endomorphisms of the parenthesized word $\mu(\mu(x_1, x_2), x_3)$ in this operad $\widehat{\mathcal{H}}$.

We easily see (by using the preservation of operadic composition structures) that t_{12} is fixed by the morphism ϕ . We can also readily obtain that the image of the homomorphism t_{23} under our morphism ϕ is given by the formula $\phi(t_{23}) = \Phi(t_{12}, t_{23})^{-1} \cdot t_{23} \cdot \Phi(t_{12}, t_{23})$, which reflects the expression of the endomorphism represented by this chord diagram t_{23} in terms of a composite of associators and of a composition product in the parenthesized chord diagram operad. We apply these formulas to the power series $\Psi(t_{12}, t_{23}) \in \mathbb{G}\widehat{\mathbb{F}}(t_{12}, t_{23})$, which we regard as a formal composite of the morphisms represented by the chord diagrams $t_{12}, t_{23} \in \widehat{\mathcal{U}}(\widehat{\mathfrak{p}}(3))$. □

We get the following final result:

THEOREM 10.3.7 (Equivalence between the operadic approach and the Drinfeld definition [48, §5]). *The graded Grothendieck-Teichmüller group $GRT^1(\mathbb{k})$ is isomorphic to the group formed by the group-like power series $\Phi(t_{12}, t_{23}) \in \mathbb{G}\widehat{\mathbb{T}}(t_{12}, t_{23})$, which satisfy the relations of Proposition 10.3.4.* □

To complete our account, we explain the definition of isomorphisms between the pro-unipotent and the graded Grothendieck-Teichmüller group from associators. We need the following proposition which is an immediate consequence of the observation of Proposition 6.1.10:

PROPOSITION 10.3.8. *Each categorical equivalence of operads $\phi : \widehat{PaB}_+ \rightarrow \widehat{CD}_+$, determined by an element in the set of Drinfeld’s associators $Ass^\mu(\mathbb{k})$ for some $\mu \in \mathbb{k}^\times$, admits a unique lifting*

$$\begin{array}{ccc} & \widehat{PaCD}_+ & \\ \exists! \tilde{\phi}_+ \nearrow & \downarrow & \\ \widehat{PaB}_+ & \xrightarrow{\phi} & \widehat{CD}_+ \end{array}$$

which defines an isomorphism of operads in groupoids $\tilde{\phi}_+ : \widehat{PaB}_+ \xrightarrow{\cong} \widehat{PaCD}_+$ and is given by the identity mapping of the magma operad at the object set level. □

This proposition implies that each set of associators $Ass^\mu(\mathbb{k})$ inherits a left action of the group $GRT^1(\mathbb{k})$ which commutes with the right action of the pro-unipotent group $GT^1(\mathbb{k})$. The following proposition is a consequence of the fact that these actions are both free and transitive:

PROPOSITION 10.3.9. *Each element Φ in the set of Drinfeld’s associators $Ass^\mu(\mathbb{k})$, where $\mu \in \mathbb{k}^\times$, determines a group isomorphism $s_\Phi : GRT^1(\mathbb{k}) \xrightarrow{\cong} GT^1(\mathbb{k})$.*

PROOF. Let $\phi : \widehat{PaB}_+ \xrightarrow{\cong} \widehat{CD}_+$ be the categorical equivalence of operads associated to our element $\Phi \in Ass^\mu(\mathbb{k})$. Let $\tilde{\phi}_+ : \widehat{PaB}_+ \xrightarrow{\cong} \widehat{PaCD}_+$ be the operad iso which lifts this categorical equivalence in Proposition 10.3.8. We define the image of an isomorphism $\psi : \widehat{PaCD}_+ \xrightarrow{\cong} \widehat{PaCD}_+$ under our iso $s_\Phi : GRT^1(\mathbb{k}) \xrightarrow{\cong} GT^1(\mathbb{k})$ by considering the composite operad morphism $s_\Phi(\psi) = \tilde{\phi}_+^{-1} \circ \psi \circ \tilde{\phi}_+$. \square

10.3.10. *Pro-unipotent structures (continued).* The graded Grothendieck-Teichmüller group $GRT^1(\mathbb{k})$ satisfies $GRT^1(\mathbb{k}) = \lim_m GRT^1(\mathbb{k})/\mathbb{F}_m GRT^1(\mathbb{k})$ where each quotient $GRT^1_m(\mathbb{k}) = GRT^1(\mathbb{k})/\mathbb{F}_m GRT^1(\mathbb{k})$ is a unipotent algebraic group, as in the case of the pro-unipotent group $GT^1(\mathbb{k})$. The action of the group $GRT^1(\mathbb{k})$ on the set of associators $Ass^\mu(\mathbb{k})$ is also pro-algebraic so that $Ass^\mu(\mathbb{k})$ forms a pro-torsor under this action (see §10.2.18).

We refer to [48, §5] for a description of the Lie algebra $\mathfrak{g}t^1$ associated with the pro-algebraic group structure on $GRT^1(\mathbb{k})$. We have a filtration $\mathbb{F}_m \mathfrak{g}t^1$ of the Lie algebra $\mathfrak{g}t^1$ so that $\mathfrak{g}t^1 = \lim_m \mathfrak{g}t^1/\mathbb{F}_m \mathfrak{g}t^1$ as in the case of the Lie algebra $\mathfrak{g}t^1$ associated to the pro-unipotent group GT^1 . The isomorphism $s_\Phi : GT^1(\mathbb{k}) \xrightarrow{\cong} GRT^1(\mathbb{k})$ associated to an associator $\Phi \in Ass^\mu(\mathbb{k})$ induces an iso $s_\Phi : \mathfrak{g}t^1 \xrightarrow{\cong} \mathfrak{g}t^1$ at the Lie algebra level.

The filtration splits on $\mathfrak{g}t^1$ (according to a result of [48]) so that this Lie algebra $\mathfrak{g}t^1$ is accordingly equipped with a canonical weight grading and we have $\mathfrak{g}t^1_m = \mathbb{E}_m^0 \mathfrak{g}t^1$. The argument of the cited reference relies on a description of the Lie algebra $\mathfrak{g}t^1$ in terms of Lie power series $P(t_{12}, t_{23}) \in \hat{\mathbb{L}}(t_{12}, t_{23})$ satisfying an analogue of the relations (a-e) of Theorem 10.3.7. The idea is that the Lie analogue of the semi-classical hexagon relation (d) follows from the other relations, which are all homogeneous. We refer to [48, §5] for details. We just record the group version of this observation:

PROPOSITION 10.3.11 (see [48, Proposition 5.7]). *In Theorem 10.3.7, the semi-classical hexagon relation (d) holds as soon as we have an element $\Phi(t_{12}, t_{23}) \in \mathbb{G}\hat{\mathbb{T}}(t_{12}, t_{23})$ satisfying the unit relation (a), the involution relation (b), the hexagon relation (c), and the pentagon relation (e) of the theorem.*

PROOF. We refer to [48, Proposition 5.7] for the proof of this result at the Lie algebra level. \square

This proposition has also the following immediate consequence:

PROPOSITION 10.3.12 (see [48, Proposition 5.9]). *The elements of the graded Grothendieck-Teichmüller group $GRT^1(\mathbb{k})$ are in bijection with the power series $\Phi(t_{12}, t_{23})$ satisfying the equations of the set of Drinfeld’s associators $Ass^0(\mathbb{k})$ for the parameter $\mu = 0$.* \square

In §10.2.12, we recall that, according to a result of Furusho [64], the pentagon equation automatically implies the hexagon equation in the set of Drinfeld associators. This result also holds for the graded Grothendieck-Teichmüller group $GRT^1(\mathbb{k})$, whose defining equations therefore reduce to the unit (a), involution (b), and pentagon equations (e) of Proposition 10.3.4.

10.4. The Knizhnik-Zamolodchikov associator

To conclude this chapter, we give an outline of Drinfeld's definition of the Knizhnik-Zamolodchikov associator [48]. This construction is well documented in the quantum group literature. Besides Drinfeld's original article [48], we can refer to the books [39, 95, 154]. The purpose of our account is just to survey the main steps of the construction, and we will give references for details.

10.4.1. *The Knizhnik-Zamolodchikov connections.* The Knizhnik-Zamolodchikov associator has complex values, and we therefore consider a complex coefficient version of the Drinfeld-Kohno Malcev algebra $\hat{\mathfrak{p}}(r)_{\mathbb{C}}$, which we get by taking the ground field $\mathbb{k} = \mathbb{C}$ in the construction of §10.2.1. For short, we write $\hat{\mathfrak{p}}(r) = \hat{\mathfrak{p}}(r)_{\mathbb{C}}$ throughout this section. We also consider the group $\hat{P}_r = \mathbb{C}\hat{U}(\hat{\mathfrak{p}}(r))$ which represents a complex Malcev completion of the pure braid group with r strands. We deal with connections in trivial fiber bundles $X \times F$ which have this group $G = \mathbb{C}\hat{U}(\hat{\mathfrak{p}}(r))$ as structure group, and are determined by connection forms $\omega \in \Omega^1(X, \mathfrak{g})$ with value in the corresponding Lie algebra $\mathfrak{g} = \hat{\mathfrak{p}}(r)$. We refer to [139] for a modern introduction to the theory of connections in general fiber bundles and the definition of connection forms with values in Lie algebras.

The Knizhnik-Zamolodchikov associator is constructed from the holonomy of certain flat connections, defined over the configuration spaces of points in the complex plane

$$F(\mathbb{C}, r) = \{(z_1, \dots, z_r) \mid z_i \neq z_j (\forall i \neq j)\}, \quad r \in \mathbb{N},$$

and determined by the complex 1-forms

$$(a) \quad \omega_{KZ} = \sum_{1 \leq i < j \leq r} \hbar t_{ij} \otimes d \log(z_i - z_j) \in \Omega^1(F(\mathbb{C}, r), \mathfrak{p}(r)),$$

where \hbar denotes a fixed parameter, we set $d \log(u) = du/u$, and t_{ij} are the generators of the Drinfeld-Kohno Lie algebra $\mathfrak{p}(r)$. These connections are called the Knizhnik-Zamolodchikov connections after the work of these authors in conformal field theory [99] (see also [53] for a reference book on this subject).

10.4.2. *The holonomy of the Knizhnik-Zamolodchikov connections.* Let $\gamma(s) = (z_1(s), \dots, z_r(s))$ be any smooth path $\gamma : [0, 1] \rightarrow F(\mathbb{C}, r)$, going from one point $\underline{a}^0 = \gamma(0)$ to another $\underline{a}^1 = \gamma(1)$ in the configuration space $F(\mathbb{C}, r)$. Let

$$(a) \quad h_\gamma : s \mapsto h_\gamma(s) \in \hat{U}(\hat{\mathfrak{p}}(r)),$$

be the solution of the differential equation

$$(b) \quad \frac{dh_\gamma}{ds} = \sum_{1 \leq i < j \leq r} \hbar \cdot (z'_i(s) - z'_j(s)) \cdot \frac{t_{ij}}{z_i(s) - z_j(s)} \cdot h_\gamma$$

with values in the complete enveloping algebra $\hat{U}(\hat{\mathfrak{p}}(r))$ and such that $h_\gamma(0) = 1$. Note that $h_\gamma(s) \otimes h_\gamma(s)$ and $\Delta h_\gamma(s)$ satisfy the same differential equation, have the same initial value $\Delta h_\gamma(0) = h_\gamma(0) \otimes h_\gamma(0) = 1 \otimes 1$, and as a consequence, agree on all $s \in [0, 1]$. The element $h_\gamma(1)$ is therefore group-like and defines an element in our structure group $\hat{P}_r = \mathbb{C}\hat{U}(\hat{\mathfrak{p}}(r))$. The iso $h_\gamma(1) : \{\gamma(0)\} \times F \rightarrow \{\gamma(1)\} \times F$ determined by the action of this group element $h_\gamma(1) \in \hat{P}_r$ on the fibers of a trivial bundle $F(\mathbb{C}, r) \times F$ with structure group \hat{P}_r represents a parallel displacement along the path γ (see [139, §6.3]). If we have $\gamma(0) = \gamma(1)$ so that γ is a loop, then this

group element $h_\gamma(1) \in \hat{P}_r$ is also called the holonomy of the connection around the loop γ .

The Knizhnik-Zamolodchikov connections are flat (see for instance [39, §16.2] or [95, §XIX.2] for the details of this verification), and as a consequence (see [139, §6.6]), we have an identity $h_\alpha(1) = h_\beta(1)$ for all homotopic paths $\alpha, \beta : [0, 1] \rightarrow F(\mathbb{C}, r)$ with a given origin $\alpha(0) = \beta(0) = \underline{a}^0$ and end-point $\alpha(1) = \beta(1) = \underline{a}^1$ in the configuration space $F(\mathbb{C}, r)$. The holonomy morphisms $h : \gamma \mapsto h_\gamma(1)$ associated to the Knizhnik-Zamolodchikov connections give rise to representations of the braid groups, the monodromy representations. The article [103], by T. Kohno, gives an explicit description of these representations. This topic is also addressed in Drinfeld’s article [48] as an application of the Knizhnik-Zamolodchikov associator construction.

10.4.3. *The definition of the Knizhnik-Zamolodchikov associator.* We fix some $r \geq 2$. We now study the system of differential equations

$$(a) \quad \frac{\partial w}{\partial z_i} = \sum_{i \neq j} \hbar \cdot \frac{t_{ij}}{z_i - z_j} \cdot w,$$

where w is a function, defined on a subdomain of the configuration space $F(\mathbb{C}, r)$, and with value in the algebra $\hat{\mathbb{U}}(\hat{\mathfrak{p}}(r))$.

We see that (a) is invariant under the action of the group of affine transformations $z \mapsto az + b$, where $a \in \mathbb{C}^\times$, $b \in \mathbb{C}$, and as a consequence, any solution of this system (a) is determined by a solution of a system depending on $r - 2$ variables (we refer to [154, §12.2] for a nice and detailed analysis of this dependence). When we take $r = 3$, we obtain

$$(b) \quad w(z_1, z_2, z_3) = (z_3 - z_1)^{\hbar(t_{12} + t_{23} + t_{13})} \cdot G\left(\frac{z_2 - z_1}{z_3 - z_1}\right),$$

where $G(z)$ is a solution of the equation

$$(c) \quad G'(z) = \hbar \cdot \left(\frac{t_{12}}{z} + \frac{t_{23}}{z - 1}\right) \cdot G(z).$$

Let $C = \{z = x + iy \mid y \neq 0 \text{ or } 0 < x < 1\}$. The classical theory of Fuchsian equations (see for instance [174, §4.3]) implies that this differential equation (c) has a unique analytic solution $G_0(z)$, defined for $z \in C$, and such that $G_0(z) \sim_{z \rightarrow 0} z^{\hbar t_{12}}$. We also have an analytic solution $G_1(z)$ such that $G_1(z) \sim_{z \rightarrow 1} (1 - z)^{\hbar t_{12}}$. The solutions w_0 and w_1 of the Knizhnik-Zamolodchikov system (a) associated to these functions are determined by asymptotic behaviors of the form:

$$(d) \quad w_0(z_1, z_2, z_3) \sim (z_2 - z_1)^{\hbar t_{12}} (z_3 - z_1)^{\hbar(t_{13} + t_{23})}, \quad \text{for } |z_2 - z_1| \ll |z_3 - z_1|,$$

$$(e) \quad w_1(z_1, z_2, z_3) \sim (z_3 - z_2)^{\hbar t_{23}} (z_3 - z_1)^{\hbar(t_{12} + t_{13})}, \quad \text{for } |z_3 - z_2| \ll |z_3 - z_1|.$$

The solutions $G_0(z)$ and $G_1(z)$ of equation (c) differ by a constant factor of the variable z . We precisely take this factor, such that $G_1(z) = G_0(z) \cdot \Phi_{KZ}(t_{12}, t_{23})$, to define the Knizhnik-Zamolodchikov associator $\Phi_{KZ}(t_{12}, t_{23}) \in \mathbb{G}\hat{\mathbb{U}}(\mathfrak{p}(3))$. This element $\Phi_{KZ}(t_{12}, t_{23}) \in \mathbb{G}\hat{\mathbb{U}}(\mathfrak{p}(3))$ can equivalently be characterized by the relation

$$(f) \quad w_1(z_1, z_2, z_3) = w_0(z_1, z_2, z_3) \cdot \Phi_{KZ}(t_{12}, t_{23}),$$

where we consider the solutions of the Knizhnik-Zamolodchikov system (a) with the asymptotic behavior prescribed in (d-e).

We aim to check that our element $\Phi_{KZ}(t_{12}, t_{23})$ satisfies the constraints of Proposition 10.2.11, for a parameter μ such that $\hbar = \mu/2i\pi$. We devote the next paragraph to a brief survey of the argument lines given in [48, §2].

10.4.4. *The verification of associator equations.* We immediately see that the reduction $t_{12} = t_{13} = 0$ makes our functions w_0 and w_1 equal, and similarly as regard the reduction $t_{13} = t_{23} = 0$. We deduce from these observations that the Knizhnik-Zamolodchikov associator satisfies the unit relation $\Phi_{KZ}(t_{12}, 0) = \Phi_{KZ}(0, t_{23}) = 1$. The involution relation $\Phi_{KZ}(t_{12}, t_{23}) \cdot \Phi_{KZ}(t_{23}, t_{12}) = 1$ follows from an easy inspection too.

To establish the pentagon equation, we consider asymptotic zones

- (a) $x_2 - x_1 \ll x_3 - x_1 \ll x_4 - x_1,$
- (b) $x_3 - x_2 \ll x_3 - x_1 \ll x_4 - x_1,$
- (c) $x_2 - x_1 \ll x_4 - x_1 \quad \text{and} \quad x_4 - x_3 \ll x_4 - x_1,$
- (d) $x_3 - x_2 \ll x_4 - x_2 \ll x_4 - x_1,$
- (e) $x_4 - x_3 \ll x_4 - x_2 \ll x_4 - x_1,$

in the range of variation formed by real variables such that $\{x_1 < x_2 < x_3 < x_4\}$. Each of these zone is associated to a vertex of the Mac Lane pentagon, with the rule that we have $x_j - x_i \ll x_l - x_k$ whenever the parenthesized word corresponding to our vertex includes the pattern $(x_k \cdots (x_i \cdots x_j) \cdots x_l)$. For instance, we associate zone (c) to the word $((x_1 x_2)(x_3 x_4))$. The Knizhnik-Zamolodchikov system $r = 4$ of §10.4.3 admits solutions $w_i = w_i(x_1, x_2, x_3, x_4)$, $i = 1, \dots, 5$, associated to the vertices of the Mac Lane pentagon, with an asymptotic of the form

- (f) $w_1 \sim (x_2 - x_1)^{\hbar t_{12}} \cdot (x_3 - x_1)^{\hbar(t_{13}+t_{23})} \cdot (x_4 - x_1)^{\hbar(t_{14}+t_{24}+t_{34})},$
- (g) $w_2 \sim (x_3 - x_2)^{\hbar t_{23}} \cdot (x_3 - x_1)^{\hbar(t_{12}+t_{13})} \cdot (x_4 - x_1)^{\hbar(t_{14}+t_{24}+t_{34})},$
- (h) $w_3 \sim (x_2 - x_1)^{\hbar t_{12}} \cdot (x_4 - x_3)^{\hbar t_{34}} \cdot (x_4 - x_1)^{\hbar(t_{13}+t_{23}+t_{14}+t_{24})},$
- (i) $w_4 \sim (x_3 - x_2)^{\hbar t_{23}} \cdot (x_4 - x_2)^{\hbar(t_{24}+t_{34})} \cdot (x_4 - x_1)^{\hbar(t_{12}+t_{13}+t_{14})},$
- (j) $w_5 \sim (x_4 - x_3)^{\hbar t_{34}} \cdot (x_4 - x_2)^{\hbar(t_{23}+t_{24})} \cdot (x_4 - x_1)^{\hbar(t_{12}+t_{13}+t_{14})}$

in the corresponding zones (a-e). The factors $(x_l - x_k)$ occurring in these asymptotic expansions correspond to the variable groupings $(x_k \dots x_l)$ that occur in the parenthesized words associated with each asymptotic zones. The exponent of this factor $x_l - x_k$ is the sum $\sum_{i,j} t_{ij}$ running over all pairs $i < j$ that come separated in the merging operation $((x_k \cdots x_i \cdots) \cdots x_j \cdots x_l)$ from which the grouping $(x_k \dots x_l)$ arises. The notation \sim asserts that w_i , $i = 1, \dots, 5$, differs from the given expansion by a function $\phi(u, v)$ which depends analytically on the asymptotic factors $(x_l - x_k)/(x_4 - x_1)$ deduced from these expansions. The existence of such functions follows from the theory of differential equations (we refer to [53] for the detailed argument).

One can prove identities $w_2 = w_1 \cdot \Phi_{KZ}(t_{12}, t_{23})$, $w_4 = w_2 \cdot \Phi_{KZ}(t_{12} + t_{13}, t_{24} + t_{34})$, $w_5 = w_4 \cdot \Phi_{KZ}(t_{23}, t_{34})$, $w_3 = w_1 \cdot \Phi_{KZ}(t_{13} + t_{23}, t_{34})$, and $w_5 = w_3 \cdot \Phi_{KZ}(t_{13} + t_{23}, t_{34})$ by checking that regularized forms of these functions (where we multiply by some asymptotic factors to eliminate divergence) satisfy the same differential equations, and agree at some initial value of the cyclically ordered quadruple $x_1 < \dots < x_4$ on the projective line \mathbb{RP}^1 (see [48, §2], or [154, §12.4] for a detailed account of this proof). The pentagon equation $\Phi(t_{12}, t_{23} + t_{34}) \cdot \Phi(t_{13} + t_{23}, t_{34}) =$

$\Phi(t_{23}, t_{34}) \cdot \Phi(t_{12} + t_{13}, t_{24} + t_{34}) \cdot \Phi(t_{12}, t_{23})$ of Proposition 10.2.11(d) immediately follows.

The hexagon equation of Proposition 10.2.11(c) is established by the same line of arguments (see for instance [154, §12.4] for full details on this verification).

The definition of the Knizhnik-Zamolodchikov associator is now complete.

Recapitulation and Outlook

The Homotopy Interpretation of the Grothendieck-Teichmüller Group

We have already observed that the classifying space of the operad of colored braids $\mathbf{B}(\mathbf{CoB})$ defines a model of the operad of little 2-discs D_2 (see §5.2). We also have $\pi_1 \mathbf{B}(\mathbf{CoB}(r)) = P_r$, the pure braid group on r strands, and $\pi_n \mathbf{B}(\mathbf{CoB}(r)) = 0$ for $n > 1$.

We now consider the classifying space operad associated the Malcev completion of the operad of colored braids $\widehat{\mathbf{CoB}}$ with the field of rationals as coefficient fields $\mathbb{k} = \mathbb{Q}$. We then have $\pi_1 \mathbf{B}(\widehat{\mathbf{PaB}}(r)) = \pi_1 \mathbf{B}(\widehat{\mathbf{CoB}}(r)) = \hat{P}_r$ for each r , where \hat{P}_r denotes the Malcev completion of the pure braid group P_r , and $\pi_n \mathbf{B}(\widehat{\mathbf{CoB}}(r)) = 0$ for all $n > 1$. We also have a canonical operad morphism $\iota : \mathbf{B}(\mathbf{CoB}) \rightarrow \mathbf{B}(\widehat{\mathbf{CoB}})$, yielded by the adjunction unit of the Malcev completion process at the level of our operads in groupoids, and this morphism clearly corresponds to the rationalization map $\iota : P_r \rightarrow \hat{P}_r$ associated to the pure braid group at the level of fundamental groups. We can therefore regard the operad $\mathbf{B}(\widehat{\mathbf{CoB}})$ as a model for the rationalization of the operad of little 2-discs, and we use this model for the definition of a rational homotopy type of E_2 -operads in simplicial sets (or in topological spaces after realization). We precisely say that an operad P is a rational E_2 -operad if this operad is connected to the classifying space of the colored braid operad by a chain of weak-equivalences of operads

$$P \xleftarrow{\sim} \cdot \xrightarrow{\sim} \mathbf{B}(\widehat{\mathbf{CoB}}),$$

where a weak-equivalence of operads consists, as we explain in the introduction of §4, of an operad morphism $\phi : R \rightarrow S$ whose components $\phi(r) : R(r) \rightarrow S(r)$ are weak-equivalences of simplicial sets (respectively, topological spaces). We have an obvious extension of this definition in the unitary setting. We then consider the unitary operad $\mathbf{B}(\widehat{\mathbf{CoB}})_+ = \mathbf{B}(\widehat{\mathbf{CoB}}_+)$ associated to the unitary extension of the Malcev completion of the colored braid operad.

The operad of parenthesized braids, considered in the definition of the Grothendieck-Teichmüller group, is endowed with a morphism towards the operad of colored braids $\omega : \mathbf{PaB} \rightarrow \mathbf{CoB}$, and this morphism defines an equivalence of groupoids in each arity by construction (a categorical equivalence of operads in the terminology of §5.2.2). This categorical equivalence induces a weak-equivalence of operads in simplicial sets (respectively, topological spaces) at the classifying space level $\mathbf{B}\omega : \mathbf{B}(\mathbf{PaB}) \xrightarrow{\sim} \mathbf{B}(\mathbf{CoB})$ (see Proposition 5.2.6). If we take the Malcev completion of the parenthesized braid operad $\widehat{\mathbf{PaB}}$, then we similarly get a weak-equivalence $\mathbf{B}\omega : \mathbf{B}(\widehat{\mathbf{PaB}}) \xrightarrow{\sim} \mathbf{B}(\widehat{\mathbf{CoB}})$ so that $\mathbf{B}(\widehat{\mathbf{PaB}})$ forms another instance of rational E_2 -operad. In the unitary setting, we similarly obtain an operad $\mathbf{B}(\widehat{\mathbf{PaB}})_+$ which forms an instance of a rational unitary E_2 -operad.

We aim to work in the homotopy category of operads in simplicial sets (respectively, topological spaces), which we intuitively define by adding the formal inverses of the weak-equivalences to the morphisms of the ordinary category. We explain in the next volume a definition of this homotopy category $\text{Ho}(\text{SimpOp})$ (respectively, $\text{Ho}(\mathcal{TopOp})$) in terms of a model structure on operads. We moreover establish the existence of an equivalence of categories between the homotopy category of operads in simplicial sets and the homotopy category operads in topological spaces. We more precisely check that we have a Quillen equivalence (we explain the definition of this notion in the next volume), defined at the level of model categories, and which induces this category equivalence at the homotopy category level. We can therefore perform homotopy computations in the category of operads in simplicial sets or in the category of operads in topological spaces equivalently. For simplicity, we assume for the moment that we work in the category of topological operads $\mathcal{Op} = \mathcal{TopOp}$.

The model category approach is better suited when we need to perform homotopy computations. The model structure notably includes the definition of a class of objects, called cofibrant, which are the analogue, in our context, of the cell complexes of topology. We can pick a cofibrant replacement \widehat{Q}_2 of the classifying space of the Malcev completion of the parenthesized braid operad $\widehat{Q}_2 \xrightarrow{\sim} \mathbf{B}(\widehat{PaB})$ in order to get a cofibrant model of rational E_2 -operad. We assume to simplify our account that the augmentation $\widehat{Q}_2 \xrightarrow{\sim} \mathbf{B}(\widehat{PaB})$ associated to this cofibrant replacement is a fibration of operads (we explain the definition of this notion in the next volume). In the case of cofibrant objects, we have an identity between the morphism set of the homotopy category, and a set of homotopy classes of morphisms in the model category. We can accordingly identify the automorphism group associated to any model of E_2 -operad with a group of homotopy classes of homotopy equivalences $\phi : \widehat{Q}_2 \xrightarrow{\sim} \widehat{Q}_2$ associated to our model.

We can also perform the cofibrant replacement process in the category of Λ -operads of §3.2. (We explain the definition of an appropriate model structure on Λ -operads in the second volume too.) We then obtain a cofibrant operad equipped with restriction morphisms, so that the unitary operad associated to this Λ -operad \widehat{Q}_{2+} defines a cofibrant model of a rational unitary E_2 -operad.

Recall that we define the Grothendieck-Teichmüller group $GT^1(\mathbb{Q})$ as a group of automorphisms associated to the unitary operad of parenthesized braids \widehat{PaB}_+ . Thus, any element of the Grothendieck-Teichmüller group $\phi \in GT^1(\mathbb{Q})$ induces an isomorphism $\mathbf{B}\phi_+ : \mathbf{B}(\widehat{PaB})_+ \xrightarrow{\sim} \mathbf{B}(\widehat{PaB})_+$, and by a standard construction of the theory of model categories, we can lift this iso to a weak-equivalence on our cofibrant replacement:

$$\begin{array}{ccc} \widehat{Q}_{2+} & \xrightarrow{\exists \widetilde{\mathbf{B}}\phi_+} & \widehat{Q}_{2+} \\ \downarrow \sim & & \downarrow \sim \\ \mathbf{B}(\widehat{PaB})_+ & \xrightarrow[\sim]{\mathbf{B}\phi_+} & \mathbf{B}(\widehat{PaB})_+ \end{array} .$$

We will see that the mapping $\mathbf{B} : \phi_+ \mapsto \widetilde{\mathbf{B}}\phi_+$ induces a group morphism

$$\mathbf{B} : GT^1(\mathbb{Q}) \rightarrow \text{Aut}_{\text{Ho}(\mathcal{TopOp})}(\widehat{Q}_{2+})$$

from $GT^1(\mathbb{Q})$ towards the group of homotopy automorphism classes of $\widehat{\mathcal{Q}}_{2+}$. We also have the following observation:

PROPOSITION A. *The morphism $B\phi_+ : B(\widehat{PaB})_+ \rightarrow B(\widehat{PaB})_+$ associated to an element of the Grothendieck-Teichmüller group $\phi \in GT^1(\mathbb{Q})$ acts identically in homology.*

PROOF. We know that the spaces $B(\widehat{PaB}(r))$ satisfy $H_*(B(\widehat{PaB}(r))) = H_*(D_2(r))$, where we consider the homology with \mathbb{Q} coefficients (see [35, §V]). We accordingly have an identity between $H_*(B(\widehat{PaB}))$ and the Gerstenhaber operad $Gerst_2$. The proposition follows from the requirement that the elements of the Grothendieck-Teichmüller group $\phi \in GT^1(\mathbb{Q})$ act identically in arity 2 and the preliminary observation that the Gerstenhaber operad is generated by operations $\mu = \mu(x_1, x_2)$ and $\lambda = \lambda(x_1, x_2)$ in arity 2 precisely (see §4.2.13). \square

Recall that we use the notation $\mathcal{O}p_1$ for the category of unitary operads in general, and the notation $\mathcal{O}p_*$, in the special case where the tensor unit of the ambient symmetric monoidal category is the final object (see §3.2). In this context, which includes the case of operads in topological spaces, the category $\mathcal{O}p_*$ actually forms a full subcategory of $\mathcal{O}p$ (with the same class of weak-equivalence). From now on, we consider that our mapping $B : \phi_+ \mapsto \widetilde{B}\phi_+$ has values in the group $\mathbf{Aut}_{\mathbf{Ho}(\mathcal{T}op\mathcal{O}p_*)}(\widehat{\mathcal{Q}}_{2+})$ formed by the homotopy automorphisms of the object $\widehat{\mathcal{Q}}_{2+}$ in the category of unitary operads $\mathcal{T}op\mathcal{O}p_*$.

We have already mentioned that we have a functor $H_* : \mathcal{T}op\mathcal{O}p \rightarrow g\mathcal{O}p$, from the category of topological operads $\mathcal{T}op\mathcal{O}p$ towards the category of graded operads $g\mathcal{O}p$, yielded by the classical homology of topology spaces, and an induced functor $H_* : \mathcal{T}op\mathcal{O}p_* \rightarrow g\mathcal{O}p_1$ on unitary operads. We easily see that homotopic operad morphisms $\phi, \psi : P \rightarrow Q$ induce the same morphism in homology: the underlying spaces $Q^{\Delta^1}(r)$ of a path object of Q in the category of operads are path objects in topological spaces; morphisms $\phi, \psi : P \rightarrow Q$, which are homotopic in the category of operads, are therefore homotopic as maps of topological spaces. Accordingly, the homology defines a functor $H_* : \mathbf{Ho}(\mathcal{T}op\mathcal{O}p) \rightarrow g\mathcal{O}p$ on the homotopy category of topological operads $\mathbf{Ho}(\mathcal{T}op\mathcal{O}p)$, and similarly in the unitary setting.

Proposition A implies that the image of our mapping $B : \phi_+ \mapsto \widetilde{B}\phi_+$ lies in the kernel of the group morphism

$$\mathbf{Aut}_{\mathbf{Ho}(\mathcal{T}op\mathcal{O}p_*)}(\widehat{\mathcal{Q}}_{2+}) \xrightarrow{H_*} \mathbf{Aut}_{g\mathcal{O}p_1}(H_*(\widehat{\mathcal{Q}}_2)_+)$$

induced by the homology functor $H_* : \mathbf{Ho}(\mathcal{T}op\mathcal{O}p_*) \rightarrow g\mathcal{O}p_1$.

In the foreword, we already mentioned that $\mathbf{Aut}_{\mathbf{Ho}(\mathcal{T}op\mathcal{O}p_*)}(\widehat{\mathcal{Q}}_{2+})$ represents the set of connected components of a space $\mathbf{hAut}_{\mathcal{T}op\mathcal{O}p_*}(\widehat{\mathcal{Q}}_{2+})$ (actually a monoid) associated to the operad $\widehat{\mathcal{Q}}_{2+}$. Motivated by the result of Proposition A, we consider the space $\mathbf{hAut}_{\mathcal{T}op\mathcal{O}p_*}^1(\widehat{\mathcal{Q}}_{2+})$ formed by the sum of connected components of $\mathbf{hAut}_{\mathcal{T}op\mathcal{O}p_*}(\widehat{\mathcal{Q}}_{2+})$ associated to maps ϕ such that $H_*(\phi) = Id$.

The main result of this work reads as follows:

THEOREM B. *The mapping $\mathbf{B} : GT^1(\mathbb{Q}) \rightarrow \mathbf{Aut}_{\mathbf{Ho}(\mathcal{T}_{op}\mathcal{O}_{p_*})}(\widehat{\mathcal{Q}}_{2+})$ induces a group isomorphism*

$$GT^1(\mathbb{Q}) \xrightarrow{\cong} \ker \underbrace{\{ \mathbf{H}_* : \mathbf{Aut}_{\mathbf{Ho}(\mathcal{T}_{op}\mathcal{O}_{p_*})}(\widehat{\mathcal{Q}}_{2+}) \rightarrow \mathbf{Aut}_{g \circ p_1}(\mathbf{H}_*(\widehat{\mathcal{Q}}_{2+})) \}}_{= \pi_0 \mathbf{hAut}_{\mathcal{T}_{op}\mathcal{O}_{p_*}}^1(\widehat{\mathcal{Q}}_{2+})},$$

and we have

$$\pi_* \left(\mathbf{H}_* \right)_{\mathcal{T}_{op}\mathcal{O}_{p_*}}^1(\widehat{\mathcal{Q}}_{2+}) = 0$$

when $\ast \geq 0$.

We give the proof of this theorem in volume II, after a tour through deformation complexes.

The Grothendieck Program

The definition of the Grothendieck-Teichmüller group by Drinfeld was motivated by applications to quantum group theory and by Grothendieck's program aiming to understand a geometric counterpart of absolute Galois groups. The purpose of this outlook chapter is to give an overview of this program, and to survey the connections between the structures occurring in our study of the homotopy of operads and the objects arising on the arithmetic side of the subject.

In Grothendieck's proposal [82], the fundamental objects are the moduli spaces of marked curves \mathcal{M}_{gn} already considered in §4.3.5 in the genus zero case. We mostly deal with this case $g = 0$ yet. We then have

$$\mathcal{M}_{0r+1} = F(\mathbb{P}^1(\mathbb{C}), r+1) / PGL_2(\mathbb{C}),$$

where we consider the diagonal action of the group $PGL_2(\mathbb{C})$ on the configuration space of points in the projective line $\mathbb{P}^1(\mathbb{C})$. In previous chapters, we used the notation $\mathbb{C}\mathbb{P}^1$, borrowed from topology, for the projective line. In what follows, we prefer to adopt the notation of algebraic geometry $\mathbb{P}^1(\mathbb{C})$ which stresses the existence of a scheme \mathbb{P}^1 underlying this topological space $\mathbb{P}^1(\mathbb{C}) = \mathbb{C}\mathbb{P}^1$.

For $r \geq 2$, we have an identity $\mathcal{M}_{0r+1} = F(\mathbb{P}^1(\mathbb{C}) \setminus \{\infty, 0, 1\}, r-2)$ since for each configuration $(z_0, \dots, z_r) \in F(\mathbb{P}^1(\mathbb{C}), r+1)$, we have one and only one transformation $g \in PGL_2(\mathbb{C})$ mapping this $\underline{z} = (z_0, \dots, z_r)$ to a configuration of the form $(\infty, 0, 1, z'_3, \dots, z'_r)$, and we can use this identity to regard each space \mathcal{M}_{0r+1} , $r \geq 2$, as a scheme defined over \mathbb{Q} in the sense of algebraic geometry. In the particular case $r = 4$, we obtain $\mathcal{M}_{04} = \mathbb{P}^1(\mathbb{C}) \setminus \{\infty, 0, 1\}$. We refer to [85] for a modern textbook on moduli spaces of curves, addressed from the algebraic geometry approach. We also refer to [125] for an account of the connections with operads and the theory of Gromov-Witten invariants.

To start our survey, we recall the construction of an action of the absolute Galois group $G_{\mathbb{Q}} = Gal(\bar{\mathbb{Q}}|\mathbb{Q})$ on the profinite fundamental group of the moduli spaces $\hat{\pi}_1(\mathcal{M}_{0r+1})$, and the relationship between the definition of this action and the definition of the Grothendieck-Teichmüller group.

The action of the absolute Galois group on the fundamental group of algebraic varieties. We first consider étale (or algebraic) fundamental groups, in the sense of [81, §V], and the homotopy exact sequence

$$(a) \quad 1 \rightarrow \pi_1^{et}(X \times_k k_s) \rightarrow \pi_1^{et}(X) \rightarrow Gal(k_s|k) \rightarrow 1,$$

which relates:

- the étale fundamental group $\pi_1^{et}(X)$ associated to any integral scheme X over a field k ,
- the étale fundamental group $\pi_1^{et}(X \times_k k_s)$ associated to the scheme $\bar{X} = X \times_k k_s$, where k_s denotes the separable closure of the field k ,

– and the absolute Galois group $\text{Gal}(k_s|k)$.

We refer to the books [137, §I.5] and [168, §5] for good introductions to this subject, besides the original text [81], where the étale fundamental group was first defined and studied.

For any $g \in \pi_1^{\text{ét}}(X)$, we consider the automorphism $c_g : \pi_1^{\text{ét}}(X \times_k k_s) \rightarrow \pi_1^{\text{ét}}(X \times_k k_s)$ given by the conjugation action $c_g(x) = gxg^{-1}$ on the normal subgroup $\pi_1^{\text{ét}}(X \times_k k_s)$. Let $\text{Out}(\pi_1^{\text{ét}}(X \times_k k_s))$ be the outer automorphism group of the group $\pi_1^{\text{ét}}(X \times_k k_s)$, the quotient of the automorphism group by the group of inner automorphisms $c_h : x \mapsto h x h^{-1}$ such that $h \in \pi_1^{\text{ét}}(X \times_k k_s)$. The mapping $\rho : g \mapsto c_g$ induces a group morphism $\rho_X : \text{Gal}(k_s|k) \rightarrow \text{Out}(\pi_1^{\text{ét}}(X \times_k k_s))$ naturally associated to the homotopy exact sequence.

We assume $k = \mathbb{Q}$, so that $k_s = \bar{\mathbb{Q}}$, and we set $G_{\mathbb{Q}} = \text{Gal}(\bar{\mathbb{Q}}|\mathbb{Q})$. We consider the analytic space $X(\mathbb{C})$ associated to the scheme X , and we assume that X is locally of finite type over \mathbb{Q} . We then have an identity (see [81, §§XII.5.1-5.2]):

$$(b) \quad \pi_1^{\text{ét}}(X \times_k k_s) = \hat{\pi}_1(X(\mathbb{C})),$$

where $\hat{\pi}_1(X(\mathbb{C}))$ denotes the profinite completion of the fundamental group of the space $X(\mathbb{C})$. We therefore have a group morphism

$$(c) \quad \rho_X : G_{\mathbb{Q}} \rightarrow \text{Out}(\hat{\pi}_1(X(\mathbb{C}))),$$

naturally associated to the scheme X , and which we deduce from the homotopy exact sequence (a).

The Teichmüller tower. The main idea of the Grothendieck program [82] is to get information on the absolute Galois group $G_{\mathbb{Q}}$ from the morphisms (c) associated to the moduli spaces $X = \mathcal{M}_{gn}$, and by using the geometry of the topological curves $\Sigma = \Sigma_{gn}$ underlying the objects $C \in \mathcal{M}_{gn}$. The morphism ρ_X is injective for $X = \mathcal{M}_{04} = \mathbb{P}^1 \setminus \{\infty, 0, 1\}$ (by a theorem of Belyi [19], see also [168, §§4.7.6-4.7.7] for an account of the arguments). The issue is therefore to characterize the image of the absolute Galois group $G_{\mathbb{Q}}$ within the fundamental group $\hat{\pi}_1(\mathbb{P}^1(\mathbb{C}) \setminus \{\infty, 0, 1\})$.

The (topological) fundamental group $\pi_1(\mathcal{M}_{gn})$ is identified with the mapping class group Γ_{gn} of the surface Σ_{gn} (up to elements of finite order). We refer to [24, §4] for a classical introduction to this subject. Recall that Γ_{gn} , explicitly defined as the group of isotopy classes of orientation preserving diffeomorphisms on Σ_{gn} , is generated by Dehn twists along curves drawn on Σ_{gn} . We can also use decompositions of the surface Σ_{gn} along curves in order to determine this group Γ_{gn} from smaller pieces involving the mapping class group of surfaces with boundary components. The proposal of [82] is to use an algebraic counterpart of the combinatoric of Dehn generators and surface decompositions in order to understand the relations satisfied by the image of the absolute Galois group $G_{\mathbb{Q}}$ in the outer automorphism groups $\text{Out}(\hat{\pi}_1(\mathcal{M}_{gn}))$. These ideas are put in applications in [86] and [140] with as main outcome a lifting of the morphisms $\rho : G_{\mathbb{Q}} \rightarrow \text{Out}(\hat{\pi}_1(\mathcal{M}_{gn}))$ to the automorphism groups $\text{Aut}(\hat{\pi}_1(\mathcal{M}_{gn}))$ and the determination of relations satisfied by the image of the absolute Galois group in $\text{Aut}(\hat{\pi}_1(\mathcal{M}_{gn}))$.

In the previous paragraph, we have not been precise about base points taken for étale fundamental groups. In basic references on the subject, the base point is just a fixed geometric point of the scheme. But this choice does not enable us to get a counterpart, at the level of étale fundamental groups, of the operations on mapping class groups associated to surface decompositions. To handle the issues, one idea is to consider the Deligne-Mumford compactification $\bar{\mathcal{M}}_{gn}$ of the moduli space \mathcal{M}_{gn}

and to take tangent vectors at the infinity of the compactification as base points for the étale fundamental groups of the schemes \mathcal{M}_{gn} . This notion of tangential base point was introduced by P. Deligne in [44, §15]. We also consider fundamental groupoids rather than fundamental groups. In [90, 91], Ihara gives a definition of an action of the absolute Galois group on the tower of fundamental groupoids with tangential base points, and use this approach to give a proof of the relations satisfied by the image of the absolute Galois group in the étale fundamental groups in the genus zero case $g = 0$. We go back to the subject of relations in the next paragraph.

We have already considered the Deligne-Mumford compactification in the genus zero case in §4.3.5. We notably recalled that the collection of these moduli spaces forms an operad $\overline{\mathcal{M}}(r) = \overline{\mathcal{M}}_{0r+1}$ with composition operations $\circ_k : \overline{\mathcal{M}}_{0r+1} \times \overline{\mathcal{M}}_{0s+1} \rightarrow \overline{\mathcal{M}}_{0r+s}$ representing the gluing of stable curves in the the moduli spaces (see [71, 125]). The tangential base points, which one considers in this case, are indexed by planar binary trees with $r+1$ leaves, corresponding to the mark points of our curves, and numbered from 0 to r (we refer to [68] for the geometric interpretation of this correspondence). The leave indexed by 0 provides such a tree with a root, and the composition operation inherited from the moduli space is identified with to the grafting operation used in the representation of the magma operad in §6.1. Thus, in order to model the combinatorial structures underlying the mapping class groups in the genus zero case, we actually deal with an operad in groupoids $\pi^{et}(\mathcal{M})_{|\Omega}$ formed by the collection of the étale fundamental groupoids of the moduli spaces \mathcal{M}_{0r+1} together with a choice of tangential base points defining an operad in sets isomorphic to the magma operad of §6.1.

) to be clarified

We have a surjective morphism $\widehat{PaB} \rightarrow \pi^{et}(\mathcal{M})_{|\Omega}$, from the profinite completion of the parenthesized braid operad of §6.2 towards this operad in groupoids $\pi^{et}(\mathcal{M})_{|\Omega}$, which, at the level of automorphism groups, maps any generating element of the pure braid group $a_{ij} \in P_r$ (see §10.2.2) to the corresponding Dehn twists in the mapping class group Γ_{r+1} .

The definition of the profinite Grothendieck-Teichmüller group. We go back to the case of the space $\mathcal{M}_{04} = \mathbb{P}^1 \setminus \{\infty, 0, 1\}$ and we consider the morphism $\rho = \rho_{\mathbb{P}^1 \setminus \{\infty, 0, 1\}}$ from the absolute Galois group $G_{\mathbb{Q}}$ to the outer automorphism group of the étale fundamental group of this scheme $\mathbb{P}^1 \setminus \{\infty, 0, 1\}$.

The topological fundamental group associated to this space is identified with the free group $\mathbb{F}(x, y)$, where x (respectively, y) is a loop turning around 0 (respectively, 1). We accordingly have $\pi_1^{et}(\mathbb{P}^1 \setminus \{\infty, 0, 1\}) = \widehat{\mathbb{F}}(x, y)$, where the notation $\widehat{\mathbb{F}}(x, y)$ now refers to the profinite completion of the free group on two generators (x, y) .

In the tangential base point approach of [90, 91], one considers a loop x based at the tangent vector $\overrightarrow{01}$, the image of this loop under the map $\theta(z) = 1 - z$, which forms a loop $\theta(x)$ based at $\overrightarrow{10}$ in the fundamental groupoid, and the straight path p , which goes from $\overrightarrow{01}$ to $\overrightarrow{10}$. The loops x and $y = p^{-1}\theta(x)p$ correspond to the previously considered generators of the fundamental group $\hat{\pi}_1(\mathbb{P}^1(\mathbb{C}) \setminus \{\infty, 0, 1\})$, based at a point near 0.

We have already mentioned that the morphisms $\rho : G_{\mathbb{Q}} \rightarrow \text{Out}(\hat{\pi}_1(\mathcal{M}_{gn}))$ can be lifted to the étale fundamental groupoids of the moduli spaces equipped with tangential base points. In the case $(g, n) = (0, 4)$, which we now examine with more details, this approach can also be used to prove that the morphisms $\rho : G_{\mathbb{Q}} \rightarrow \text{Out}(\widehat{\mathbb{F}}(x, y))$ admits a lifting to the group of automorphisms of the free

group $\widehat{\mathbb{F}}(x, y)$. To be more precise, one can prove that we have an automorphism $\rho(\sigma) : \widehat{\mathbb{F}}(x, y) \rightarrow \widehat{\mathbb{F}}(x, y)$, canonically associated to any element $\sigma \in G_{\mathbb{Q}}$, such that $\rho(\sigma)(x) = x^{\lambda}$, where $\lambda = \chi(\sigma)$ denotes the image of σ under the cyclotomic character $\chi : G_{\mathbb{Q}} \rightarrow \widehat{\mathbb{Z}}^{\times}$, and $\rho(\sigma)(y) = f_{\sigma}(x, y)^{-1} y^{\lambda} f_{\sigma}(x, y)$ for some $f_{\sigma} = f_{\sigma}(x, y) \in \widehat{\mathbb{F}}(x, y)$. Furthermore, by using paths in the moduli spaces $\mathcal{M}_{04} = \mathbb{P}^1 \setminus \{\infty, 0, 1\}$ and $\mathcal{M}_{05} = (\mathbb{P}^1 \setminus \{\infty, 0, 1\}) \times (\mathbb{P}^1 \setminus \{\infty, 0, 1\}) \setminus \Delta$, one can prove that this group element $f_{\sigma}(x, y)$ satisfies profinite analogues (with extra λ exponent factors) of the involution, pentagon and hexagon relations of §10.1. The profinite Grothendieck-Teichmüller group \widehat{GT} , as defined by V. Drinfeld in [48], precisely consists of the group automorphisms $\phi : \widehat{\mathbb{F}}(x, y) \rightarrow \widehat{\mathbb{F}}(x, y)$ of the form:

$$\begin{aligned}\phi(x) &= x^{\lambda}, \\ \phi(y) &= f(x, y)^{-1} \cdot y^{\lambda} \cdot f(x, y),\end{aligned}$$

where we consider any pair $(\lambda, f(x, y))$ such that the geometric involution, pentagon and hexagon constraints hold. The construction of the action of the absolute Galois group $G_{\mathbb{Q}}$ on the étale fundamental group of the moduli spaces \mathcal{M}_{0r+1} therefore yields an injective group morphism $\rho : G_{\mathbb{Q}} \hookrightarrow \widehat{GT}$.

The proof of Drinfeld's involution, pentagon and hexagon relations for the pair $(\lambda, f_{\sigma}(x, y))$ associated to a Galois group element $\sigma \in G_{\mathbb{Q}}$ is given in [90, 91] by using the fundamental groupoids with tangential base points approach. We also refer to [117] for another approach, relying on a cohomological interpretation of Drinfeld's relations, of this question.

We note that the group \widehat{GT} encodes the geometric information captured by the action of the absolute Galois group in genus zero only. We have a generalization of this group, defined by considering the whole collection of moduli spaces \mathcal{M}_{gn} , introduced by P. Lochak, H. Nakamura, and L. Schneps in [116]. We do not go further into applications of Grothendieck-Teichmüller groups in the profinite setting. We refer to the cited articles for the reader willing to learn more about this subject. We now give a brief survey on an arithmetic counterpart of the pro-unipotent groups of §10.

The category of mixed Tate motives. The pro-unipotent groups $GT(\mathbb{Q})$ and $GRT(\mathbb{Q})$ are actually related to motivic fundamental groups of Tate motives.

Briefly recall that the idea of a motive was introduced by Grothendieck as an attempt to unify the cohomology theories occurring in algebraic geometry: the singular cohomology of the topological space underlying any algebraic variety or Betti cohomology, the de Rham cohomology, the l -adic cohomologies, the crystalline cohomology, and more generally, any suitable cohomology theory satisfying the Weil axioms. Motives are supposed to form an abelian category under the category of algebraic varieties so that the mapping $M : X \mapsto M(X)$, which assigns a motive $M(X)$ to any algebraic variety X , defines a universal Weil cohomology theory. We refer to [6] for a comprehensive introduction to this subject.

The definition of a category of motives with all expected properties has not been established yet. Nonetheless, a definition of a category of pure motives (well suited when we restrict ourselves to smooth projective varieties), has been proposed by Grothendieck (see [6]). In a more general setting, we have Deligne's language of realization systems, which formalize the structures carried by the images of a motive under a cohomology theory, as well as Hanamura's [84], Levine's [114], and

Voevodsky's [175] triangulated categories of mixed motives, which define candidates for the derived category of the abelian category of mixed motives.

The connection between Grothendieck-Teichmüller groups and motives is made precise in the work of Deligne-Goncharov [45] and in the work of Terasoma [173]. We then mostly consider a category of (rational) mixed Tate motives, which is defined as a subcategory of the category of mixed motives. We follow [45] for our account. We consider varieties and motives defined over a field k of characteristic 0.

Recall that the Tate motive T is classically defined as the tensor inverse $T = L^{-1}$ of a motive L such that $M(\mathbb{P}^1) = \mathbb{1} \oplus L$, where we consider a splitting of the motive associated to the projective line \mathbb{P}^1 . The triangulated category of rational Tate motives, denoted by $DMT(k)_{\mathbb{Q}}$, is generated by iterated extensions of shifted objects $\mathbb{Q}(n)$ in any of our rational triangulated categories of mixed motives, where we set $\mathbb{Q}(1) = T \otimes \mathbb{Q}$ for the object representing the Tate motive in this triangulated category, and $\mathbb{Q}(n) = \mathbb{Q}(1)^{\otimes n}$. This category $DMT(k)_{\mathbb{Q}}$ is actually identified with the derived category of an abelian category $MT(k)$ as soon as the Beilinson-Soulé vanishing conjecture holds, and we know at least this is so when k is a number field (see [113]). We refer to this category $MT(k)$ as the abelian category of mixed Tate motives over k .

Let \mathcal{O}_S be a ring of S -integers in the number field k . In [45], a subcategory of mixed Tate motives over \mathcal{O}_S , denoted by $MT(k)$, is also defined within $MT(k)$. One can apply the Tannakian formalism to identify this category $MT(\mathcal{O}_S)$ with the category of representations of an affine group scheme G_{ω} associated to a realization functor $\omega : MT(\mathcal{O}_S) \rightarrow \text{Mod}_{\mathbb{Q}}$. Deligne and Goncharov also defines an affine group scheme $G_{MT(\mathcal{O}_S)}$ (a commutative Hopf algebra) in the category $MT(\mathcal{O}_S)$ so that $\omega(G_{MT(\mathcal{O}_S)}) = \text{Aut}^{\otimes}(\omega)$, and call this object $G_{MT(\mathcal{O}_S)}$ the fundamental group of the category of mixed Tate motives $MT(\mathcal{O}_S)$. This is this group which replaces the absolute Galois in the pro-unipotent setting.

The motivic fundamental group of Tate motives. We now assume $k = \mathbb{Q}$ and $\mathcal{O}_S = \mathbb{Z}$. Deligne-Goncharov [45] and Terasoma [173] define a motivic counterpart $\pi_1^{\text{mot}}(\mathbb{P}^1 \setminus \{\infty, 0, 1\})$, in the category $MT(\mathbb{Z})$, of the fundamental group of the variety $\mathbb{P}^1 \setminus \{\infty, 0, 1\}$. This motivic fundamental group $\pi_1^{\text{mot}}(\mathbb{P}^1 \setminus \{\infty, 0, 1\})$ has a Betti realization $\pi_1^B(\mathbb{P}^1 \setminus \{\infty, 0, 1\})$, which is identified with the pronunipotent completion of the fundamental group of the topological space $\mathbb{P}^1(\mathbb{C}) \setminus \{\infty, 0, 1\}$, as well as a de Rham realization $\pi_1^{DR}(\mathbb{P}^1 \setminus \{\infty, 0, 1\})$ (we refer to [44, §10] for the original definition of this de Rham realization of fundamental groups).

We use the notation $G_{MT(\mathbb{Z})}^B$ for the Betti realization of the motivic fundamental group $G_{MT(\mathbb{Z})}$ of the integral category of mixed Tate motives $MT(\mathbb{Z})$. We have a group morphism $\rho : G_{MT(\mathbb{Z})}^B \rightarrow \text{Aut}(\pi_1^B(\mathbb{P}^1 \setminus \{\infty, 0, 1\}))$ defining a motivic analogue, in the Betti realization, of the previously considered morphism $\rho : G_{\mathbb{Q}} \rightarrow \text{Aut}(\hat{\pi}_1(\mathbb{P}^1 \setminus \{\infty, 0, 1\}))$, where we consider the usual Galois group $G_{\mathbb{Q}} = \text{Gal}(\bar{\mathbb{Q}}|\mathbb{Q})$. We also have $\pi_1^B(\mathbb{P}^1 \setminus \{\infty, 0, 1\}) = \hat{\mathbb{F}}(x, y)$, the pronunipotent completion of the free group with two generators, and one can prove, just as in the profinite setting, that the morphism ρ factors through the Grothendieck-Teichmüller group $GT(\mathbb{Q})$ regarded as a subset of the automorphism group of this free group $\hat{\mathbb{F}}(x, y)$ (see [172] for an outline of the arguments). Note that we now consider the whole group $GT(\mathbb{Q})$

which differs from the pronipotent group $GT^1(\mathbb{Q})$ of §10.1 by a multiplicative factor \mathbb{Q}^\times .

The obtained morphism

$$(d) \quad \rho : G_{MT(\mathbb{Z})}^B \rightarrow GT(\mathbb{Q})$$

is conjecturally an isomorphism (Deligne-Ihara). A result of F. Brown [36] gives the injectivity of this morphism.

Let us mention that the group $G_{MT(\mathbb{Z})}^B$ is according to a statement of [45], the (product of a scalar factor with the) pronipotent completion of a free group on a sequence of generators $s_3, s_5, \dots, s_{2n+1}, \dots$. The Deligne-Ihara conjecture therefore amounts to the conjecture that we have an identity between:

- the Lie algebra $\mathfrak{gt}^1(\mathbb{Q})$ of the pronipotent Grothendieck-Teichmüller group $GT^1(\mathbb{Q})$ (see §10.1.7), or equivalently, the Lie algebra $\mathfrak{grt}^1(\mathbb{Q})$ of the graded Grothendieck-Teichmüller group $GRT^1(\mathbb{Q})$ (see §10.3.10),
- and a free complete Lie algebra $\hat{\mathbb{L}}(s_3, s_5, \dots, s_{2n+1}, \dots)$.

The Knizhnik-Zamolodchikov associator and multizetas. The Knizhnik-Zamolodchikov associator of §10.4 has also an interpretation in terms of a period isomorphism connecting the Betti realization and the de Rham realization of the motivic fundamental group $\pi_1^{mot}(\mathbb{P}^1 \setminus \{\infty, 0, 1\})$ (see [172] for an introduction to this subject).

The Knizhnik-Zamolodchikov associator actually represents a generating power series of the multizeta values:

$$\zeta(k_1, \dots, k_r) = \sum_{n_1 > \dots > n_r > 0} \frac{1}{n_1^{k_1} \cdot \dots \cdot n_r^{k_r}}.$$

The number $\zeta(k_1, \dots, k_r)$ precisely appears (with a correcting sign) as the coefficient of the term $x^{k_1-1} y x^{k_2-1} y \dots y x^{k_r-1}$ in the expansion of the power series of the Knizhnik-Zamolodchikov associator $\Phi(x, y) \in \mathbb{G}\hat{\mathbb{T}}(x, y)$ in the completed tensor algebra $\hat{\mathbb{T}}(x, y)$. The other terms of this expansion can be obtained from multizetas by an explicit procedure (see [110]).

The multizeta values form an algebra. The result established by F. Brown in [36] actually asserts that a motivic counterpart of this algebra, where we only retain relations underlying an algebraic definition of multizetas in terms of motivic periods (see [79]), is isomorphic to the completed tensor algebra underlying the free Malcev complete group $G_{MT(\mathbb{Z})}^B$. The injectivity of the map (d) in the Deligne-Ihara conjecture arises as a consequence of this result.

Bibliography

- [1] E. Abe, *Hopf algebras*. Cambridge Tracts in Mathematics 74, Cambridge University Press, 1980.
- [2] J.F. Adams, *Infinite loop spaces*. Annals of Mathematics Studies 90, Princeton University Press, 1978.
- [3] M. Aguiar, S. Mahajan, *Coxeter groups and Hopf algebras. With a foreword by Nantel Bergeron*. Fields Institute Monographs 23, American Mathematical Society, 2006.
- [4] ———, *Monoidal functors, species and Hopf algebras. With forewords by Kenneth Brown and Stephen Chase and André Joyal*. CRM Monograph Series 29, American Mathematical Society, 2010.
- [5] A. Alekseev, C. Torossian, *Kontsevich deformation quantization and flat connections*. Comm. Math. Phys. 300 (2010), 47–64.
- [6] Y. André, *Une introduction aux motifs (motifs purs, motifs mixtes, périodes)*. Panoramas et Synthèses 17, Société Mathématique de France, 2004.
- [7] V.I. Arnold, *The cohomology ring of the group of dyed braids*. Mat. Zametki 5 (1969), 227–231.
- [8] E. Artin, *Theorie der Zöpfe*. Hamb. Abh. 4 (1925), 47–72.
- [9] ———, *Theory of braids*. Ann. of Math. 48 (1947), 101–126.
- [10] M. Aubry, D. Chataur, *Cooperads and coalgebras as closed model categories*. J. Pure Appl. Algebra 180 (2003), 1–23.
- [11] S. Axelrod, I. Singer, *Chern-Simons perturbation theory. II*. J. Differential Geom. 39 (1994), 173–213.
- [12] C. Balteanu, Z. Fiedorowicz, R. Schwänzl, R. Vogt, *Iterated monoidal categories*. Adv. Math. 176 (2003), 277–349.
- [13] D. Bar-Natan, *On associators and the Grothendieck-Teichmüller group, I*. Selecta Math. 4 (1998), 183–212.
- [14] M.G. Barratt, P.J. Eccles, Γ^+ -structures. I. A free group functor for stable homotopy theory. Topology 13 (1974), 25–45.
- [15] M.A. Batanin, *Monoidal globular categories as a natural environment for the theory of weak n -categories*. Adv. Math. 136 (1998), 39–103.
- [16] ———, *The Eckmann-Hilton argument and higher operads*. Adv. Math. 217 (2008), 334–385.
- [17] ———, *Symmetrization of n -operads and compactification of real configuration spaces*. Adv. Math. 211 (2007), 684–725.
- [18] ———, *Locally constant n -operads as higher braided operads*. J. Noncommut. Geom. 4 (2010), 237–263.
- [19] G. Belyi, *Galois extensions of a maximal cyclotomic field*. Izv. Akad. Nauk SSSR Ser. Mat. 43 (1979), 267–276, 479.
- [20] C. Berger, *Opérides cellulaires et espaces de lacets itérés*. Ann. Inst. Fourier 46 (1996), 1125–1157.
- [21] ———, *Combinatorial models for real configuration spaces and E_n -operads*, in “Operads: Proceedings of Renaissance Conferences (Hartford, CT/Luminy, 1995)”. Contemp. Math. 202, Amer. Math. Soc. (1997), 37–52.
- [22] C. Berger, I. Moerdijk, *Axiomatic homotopy theory for operads*. Comment. Math. Helv. 78 (2003), 805–831.
- [23] ———, *The Boardman-Vogt resolution of operads in monoidal model categories*. Topology 45 (2006), 807–849.

- [24] J.S. Birman, *Braids, links, and mapping class groups*. Annals of Mathematics Studies 82, Princeton University Press, 1974.
- [25] J. Boardman, R. Vogt, *Homotopy-everything H-spaces* Bull. Amer. Math. Soc. 74 (1968), 1117–1122.
- [26] ———, *Homotopy invariant algebraic structures on topological spaces*. Lecture Notes in Mathematics 347, Springer-Verlag, 1973.
- [27] F. Borceux, *Handbook of categorical algebra. 1. Basic category theory*. Encyclopedia of Mathematics and its Applications 50, Cambridge University Press, 1994.
- [28] ———, *Handbook of categorical algebra. 2. Categories and structures*. Encyclopedia of Mathematics and its Applications 51, Cambridge University Press, 1994.
- [29] F. Borceux, G. Janelidze, *Galois theories*. Cambridge Studies in Advanced Mathematics 72, Cambridge University Press, 2001.
- [30] A. Borel, *Linear algebraic groups. Second edition*. Graduate Texts in Mathematics 126, Springer-Verlag, 1991.
- [31] N. Bourbaki, *Algèbre, chapitres 1 à 3 (reprint of the 1970 original)*. Springer-Verlag, 2007.
- [32] ———, *Groupes et algèbres de Lie, chapitres 2 et 3 (reprint of the 1972 original)*. Springer-Verlag, 2006.
- [33] A.K. Bousfield, *Homotopy spectral sequences and obstructions*. Israel J. Math. 66 (1989), 54–104.
- [34] A. Bousfield, V. Gugenheim, *On PL De Rham theory and rational homotopy type*. Memoirs of the American Mathematical Society 179, American Mathematical Society, 1976.
- [35] A. Bousfield, D. Kan, *Homotopy limits, completions and localizations*. Lecture Notes in Mathematics 304, Springer-Verlag, 1972.
- [36] F. Brown, *Mixed Tate motives over \mathbb{Z}* . Ann. of Math. 175 (2012), 949–976.
- [37] H. Cartan, *Théories cohomologiques*. Invent. Math. 35 (1976), 261–271.
- [38] P. Cartier, *A primer of Hopf algebras*. Prépublication Inst. Hautes Études Sci. (2006).
- [39] V. Chari, A. Pressley, *A guide to quantum groups*. Cambridge University Press, 1994.
- [40] F. Cohen, *The homology of \mathcal{C}_{n+1} -spaces, $n \geq 0$, in “The homology of iterated loop spaces”*. Lecture Notes in Math. 533, Springer-Verlag (1976), 207–351.
- [41] F. Cohen, T. Lada, P. May, *The homology of iterated loop spaces*. Lecture Notes in Mathematics 533, Springer-Verlag, 1976.
- [42] A. Connes, D. Kreimer, *Hopf algebras, renormalization and noncommutative geometry*. Comm. Math. Phys. 199 (1998), 203–242.
- [43] E.B. Curtis, *Simplicial homotopy theory*. Adv. in Math. 6 (1971) 107–209.
- [44] P. Deligne, *Le groupe fondamental de la droite projective moins trois points, in “Galois groups over \mathbb{Q} (Berkeley, CA, 1987)”*. Math. Sci. Res. Inst. Publ. 16 Springer-Verlag (1989), 79–297.
- [45] P. Deligne, A. Goncharov, *Groupes fondamentaux motiviques de Tate mixte*. Ann. Sci. École Norm. Sup. 38 (2005), 1–56.
- [46] P. Deligne, D. Mumford, *The irreducibility of the space of curves of given genus*. Publ. Math. Inst. Hautes Études Sci. 36 (1969), 75–109.

- [47] V.G. Drinfeld, *Quantum groups*, in “Proceedings of the International Congress of Mathematicians, Vol. 1, 2 (Berkeley, 1986)”. Amer. Math. Soc. (1987), 798–820.
- [48] ———, *On quasitriangular quasi-Hopf algebras and on a group that is closely connected with $\text{Gal}(\overline{Q}/Q)$* . Algebra i Analiz 2 (1990), 149–181. English translation in Leningrad Math. J. 2 (1991), 829–860.
- [49] G. Drummond-Cole, *Homotopically trivializing the circle in framed little discs*. J. Topology, to appear.
- [50] W. Dwyer, D. Kan, *Function complexes in homotopical algebra*. Topology 19 (1980), 425–440.
- [51] ———, *Calculating simplicial localizations*. J. Pure and Appl. Algebra 18 (1980), 17–35.
- [52] W.G. Dwyer, J. Spalin’ski, *Homotopy theories and model categories*, in “Handbook of algebraic topology”. North-Holland (1995), 73–126
- [53] P. Etingof, I. Frenkel, A. Kirillov, *Lectures on representation theory and Knizhnik-Zamolodchikov equations*. Mathematical Surveys and Monographs 58, American Mathematical Society, 1998.
- [54] Y. Félix, S. Halperin, J.-C. Thomas, *Rational homotopy theory*. Graduate Texts in Mathematics 205, Springer-Verlag, 2001.
- [55] Y. Félix, J. Oprea, D. Tanré, *Algebraic models in geometry*. Oxford Graduate Texts in Mathematics 17, Oxford University Press, 2008.
- [56] Z. Fiedorowicz, *The symmetric bar construction*. Preprint (1996).
- [57] T. Fox, M. Markl, *Distributive laws, bialgebras, and cohomology*, in “Operads: proceedings of renaissance conferences (Hartford, CT/Luminy, 1995)”. Contemp. Math. 202, Amer. Math. Soc. (1997), 167–206.
- [58] R.H. Fox, L. Neuwirth, *The braid groups*. Math. Scand. 10 (1962), 119–126.
- [59] B. Fresse, *Koszul duality of operads and homology of partition posets*, in “Homotopy theory: relations with algebraic geometry, group cohomology, and algebraic K -theory”. Contemp. Math. 346, Amer. Math. Soc. (2004), 115–215.
- [60] ———, *Modules over operads and functors*. Lecture Notes in Mathematics 1967, Springer-Verlag, 2009.
- [61] ———, *Props in model categories and homotopy invariance of structures*. Georgian Math. J. 17 (2010), 79–160.
- [62] W. Fulton, R. MacPherson, *A compactification of configuration spaces*. Ann. of Math. 139 (1994), 183–225.
- [63] H. Furusho, *Multiple zeta values and Grothendieck-Teichmüller groups*, in “Primes and knots”. Contemp. Math. 416, Amer. Math. Soc. (2006), 49–82.
- [64] ———, *Pentagon and hexagon equations*. Ann. of Math. 171 (2010), 545–556.
- [65] P. Gabriel, M. Zisman, *Calculus of fractions and homotopy theory*. Ergebnisse der Mathematik und ihrer Grenzgebiete 35, Springer-Verlag, 1967.
- [66] G. Gaiffi, *Models for real subspace arrangements and stratified manifolds*. Int. Math. Res. Not. (2003), 627–656.
- [67] I. Gel’fand, M. Kapranov, A. Zelevinsky, *Discriminants, resultants, and multidimensional determinants*. Mathematics: Theory & Applications. Birkhäuser, MA, 1994.
- [68] L. Gerritzen, F. Herrlich, M. van der Put, *Stable n -pointed trees of projective lines*. Nederl. Akad. Wetensch. Indag. Math. 50 (1988), 131–163.

- [69] M. Gerstenhaber, *The cohomology structure of an associative ring*. Ann. of Math. 78 (1963), 267–288.
- [70] E. Getzler, *Batalin-Vilkovisky algebras and two-dimensional topological field theories*. Comm. Math. Phys. 159 (1994), 265–285.
- [71] ———, *Operads and moduli spaces of genus 0 Riemann surfaces*, in “The moduli space of curves”. Progr. Math. 129, Birkhäuser (1995), 199–230.
- [72] E. Getzler, P. Goerss, *A model category structure for differential graded coalgebras*. Preprint (1999).
- [73] E. Getzler, J. Jones, *Operads, homotopy algebra and iterated integrals for double loop spaces*. Preprint [arXiv:hep-th/9403055](https://arxiv.org/abs/hep-th/9403055) (1994).
- [74] G. Ginot, *Homologie et modèle minimal des algèbres de Gerstenhaber*. Ann. Math. Blaise Pascal 11 (2004), 95–127.
- [75] V. Ginzburg, M. Kapranov, *Koszul duality for operads*. Duke Math. J. 76 (1995), 203–272.
- [76] P.G. Goerss, *Simplicial chains over a field and p-local homotopy theory*. Math. Z. 220 (1995), 523–544.
- [77] P.G. Goerss, M. Hopkins, *André-Quillen (Co-)homology for simplicial algebras over simplicial operads*, in “Une dégustation topologique [Topological morsels]: homotopy theory in the Swiss Alps”. Contemp. Math. 265 (2000), 41–85.
- [78] P.G. Goerss, J.F. Jardine, *Simplicial homotopy theory*. Progress in Mathematics 174, Birkhäuser Verlag, 1999.
- [79] A.B. Goncharov, *Galois symmetries of fundamental groupoids and noncommutative geometry*. Duke Math. J. 128 (2005), 209–284.
- [80] P.-P. Grivel, *Une histoire du théorème de Poincaré-Birkhoff-Witt*. Expo. Math. 22 (2004), 145–184.
- [81] A. Grothendieck (Ed.), *Revêtements étales et groupe fondamental (SGA 1)*. Lecture Notes in Mathematics 224, Springer-Verlag, 1971. Reprinted in the series Documents Mathématiques 3, Société Mathématique de France, 2003.
- [82] A. Grothendieck, *Esquisse d’un programme*, in “Geometric Galois actions, 1” London Math. Soc. Lecture Note Ser. 242, Cambridge Univ. Press (1997), 5–48.
- [83] P. Hall, *A contribution to the theory of groups of prime power order*. Proc. London Math. Soc. 36 (1933), 29–95.
- [84] M. Hanamura, *Mixed motives and algebraic cycles I*. Math. Res. Lett. 2 (1995), 811–821.
- [85] J. Harris, I. Morrison, *Moduli of curves*. Graduate Texts in Mathematics 187, Springer-Verlag 1998.
- [86] A. Hatcher, P. Lochak, L. Schneps, *On the Teichmüller tower of mapping class groups*. J. Reine Angew. Math. 521 (2000), 1–24.
- [87] V. Hinich, *Homological algebra of homotopy algebras*. Comm. Algebra 25 (1997), 3291–3323.
- [88] P. Hirschhorn, *Model categories and their localizations*. Mathematical Surveys and Monographs 99, American Mathematical Society, 2003.
- [89] M. Hovey, *Model categories*. Mathematical Surveys and Monographs 63, American Mathematical Society, 1999.
- [90] Y. Ihara, *Braids, Galois groups, and some arithmetic functions*. in “Proceedings of the International Congress of Mathematicians, Vol. I, II (Kyoto,

- 1990)”. Math. Soc. Japan (1991), 99–120.
- [91] Y. Ihara, *On the embedding of $\text{Gal}(\overline{\mathbb{Q}}/\mathbb{Q})$ into \widehat{GT} . With an appendix by Michel Emsalem and Pierre Lochak*, in “The Grothendieck theory of dessins d’enfants (Luminy, 1993)”. London Math. Soc. Lecture Note Ser. 200, Cambridge Univ. Press (1994), 289–321.
- [92] I. James, *Reduced product spaces*. Ann. of Math. (2) 62 (1955), 170–197.
- [93] A. Joyal, R. Street, *Braided tensor categories*. Adv. Math. 102 (1993), 20–78.
- [94] D. Kan, *Adjoint functors*. Trans. Amer. Math. Soc. 87 (1958), 294–329.
- [95] C. Kassel, *Quantum groups*. Graduate Texts in Mathematics 155, Springer-Verlag, 1995.
- [96] C. Kassel, V. Turaev, *Braid groups*. Graduate Texts in Mathematics 247, Springer-Verlag, 2008.
- [97] S. Keel, *Intersection theory of moduli space of stable n -pointed curves of genus zero*. Trans. Amer. Math. Soc. 330 (1992), 545–574.
- [98] G.M. Kelly, *On the operads of P. May*. Repr. Theory Appl. Categ. 13 (2005), 1–13.
- [99] V. Knizhnik, A. Zamolodchikov, *Current algebra and Wess-Zumino model in two dimensions*. Nuclear Phys. B 247 (1984), 83–103.
- [100] F. Knudsen, *The projectivity of the moduli space of stable curves. II and III*. Math. Scand. 52 (1983), 161–199 and 200–212.
- [101] S. Kobayashi, K. Nomizu, *Foundations of differential geometry, I-II*. Wiley-Interscience Publications, 1963.
- [102] T. Kohno, *Série de Poincaré-Koszul associée aux groupes de tresses pures*. Invent. Math. 82 (1985), 57–75.
- [103] ———, *Monodromy representations of braid groups and Yang-Baxter equations*. Ann. Inst. Fourier 37 (1987), 139–160.
- [104] M. Kontsevich, *Operads and motives in deformation quantization*. Lett. Math. Phys. 48 (1999), 35–72.
- [105] ———, *Deformation quantization of Poisson manifolds*. Lett. Math. Phys. 66 (2003), 157–216.
- [106] M. Kontsevich, Y. Soibelman, *Deformations of algebras over operads and Deligne’s conjecture*, in “Conférence Moshé Flato 1999, Vol. I (Dijon, 1999)”. Math. Phys. Stud. 21, Kluwer Acad. Publ. (2000), 255–307.
- [107] P. Lambrechts, I. Volić, *Formality of the little N -disks operad*. Preprint arXiv:0808.0457 (2008).
- [108] M. Lazard, *Sur les groupes nilpotents et les anneaux de Lie*. Ann. Sci. École Norm. Sup. 71 (1954), 101–190.
- [109] ———, *Lois de groupes et analyseurs*. Ann. Sci. École Norm. Sup. 72 (1955), 299–400.
- [110] Thang Tu Quoc Le, J. Murakami, *Kontsevich’s integral for the Kauffman polynomial*. Nagoya Math. J. 142 (1996), 39–65.
- [111] C. Lee, *The associahedron and triangulations of the n -gon*. European J. Combin. 10 (1989), 551–560.
- [112] T. Leinster, *Higher operads, higher categories*. London Mathematical Society Lecture Note Series 298, Cambridge University Press, 2004.
- [113] M. Levine, *Tate motives and the vanishing conjectures for algebraic K-theory*, in “Algebraic K-Theory and Algebraic Topology (Lake Louise, 1991)”. NATO Adv. Sci. Inst. Ser. C Math. Phys. 407, Kluwer (1993), 167–188.

- [114] M. Levine, *Mixed motives*. Mathematical Surveys and Monographs 57, American Mathematical Society, 1998.
- [115] M. Livernet, *Homotopie rationnelle des algèbres sur une opérade*. Thèse de Doctorat, Université Strasbourg 1, 1998.
- [116] P. Lochak, H. Nakamura, L. Schneps, *On a new version of the Grothendieck-Teichmüller group*. C. R. Acad. Sci. Paris Sér. I Math. 325 (1997), 11–16.
- [117] P. Lochak, L. Schneps, *A cohomological interpretation of the Grothendieck-Teichmüller group. With an appendix by C. Scheiderer*. Invent. Math. 127 (1997), 571–600.
- [118] J.-L. Loday, *Série de Hausdorff, idempotents eulériens et algèbres de Hopf*. Exposition. Math. 12 (1994), no. 2, 165–178.
- [119] ———, *Realization of the Stasheff polytope*. Arch. Math. 83 (2004), 267–278.
- [120] J.-L. Loday, B. Vallette, *Algebraic operads*. Grundlehren der mathematischen Wissenschaften 346, Springer-Verlag, 2012.
- [121] S. Mac Lane, *Homology*. Grundlehren der mathematischen Wissenschaften 114, Springer-Verlag, 1963.
- [122] ———, *Categories for the working mathematician (second edition)*. Graduate Texts in Mathematics 5, Springer-Verlag, 1998.
- [123] W. Magnus, A. Karass, D. Solitar, *Combinatorial group theory*. Dover Publications, 1966.
- [124] A.I. Mal’cev, *Nilpotent torsion-free groups*. Izvestiya Akad. Nauk. SSSR. Ser. Mat. 13 (1949), 201–212.
- [125] Y. Manin, *Frobenius manifolds, quantum cohomology, and moduli spaces*. Colloquium Publications 47, American Mathematical Society, 1999.
- [126] M. Markl, *Distributive laws and Koszulness*. Ann. Inst. Fourier 46 (1996), 307–323.
- [127] ———, *Models for operads*. Comm. Algebra 24 (1996), 1471–1500.
- [128] ———, *A compactification of the real configuration space as an operadic completion*. J. Algebra 215 (1999), 185–204.
- [129] ———, *Operads and PROPs*, in “Handbook of Algebra, Vol. 5”. North-Holland (2008), 87–140.
- [130] ———, *Deformation theory of algebras and their diagrams*. CBMS Regional Conference Series in Mathematics 116, American Mathematical Society, 2012.
- [131] M. Markl, S. Shnider, J. Stasheff, *Operads in algebra, topology and physics*. Mathematical Surveys and Monographs 96, American Mathematical Society, 2002.
- [132] W. Massey, *A basic course in algebraic topology*. Graduate Texts in Mathematics 127, Springer-Verlag, 1991.
- [133] P. May, *Simplicial objects in algebraic topology (reprint of the 1967 original)*. Chicago Lectures in Mathematics, University of Chicago Press, Chicago, 1992.
- [134] ———, *The geometry of iterated loop spaces*. Lecture Notes in Mathematics 271, Springer-Verlag, 1972.
- [135] J.E. McClure, J.H. Smith, *A solution of Deligne’s Hochschild cohomology conjecture*, in “Recent progress in homotopy theory (Baltimore, MD, 2000)”. Contemp. Math. 293, Amer. Math. Soc. (2002), 153–193.
- [136] ———, *Multivariable cochain operations and little n -cubes*. J. Amer. Math. Soc. 16 (2003), 681–704.

- [137] J. Milne, *Étale cohomology*. Annals of Mathematics Studies 33, Princeton University Press, 1980.
- [138] J. Milnor, J. Moore, *On the structure of Hopf algebras*. Ann. of Math. 81 (1965), 211–264.
- [139] S. Morita, *Geometry of differential forms*. Translated from the two-volume Japanese original (1997, 1998) by Teruko Nagase and Katsumi Nomizu. Translations of Mathematical Monographs 201, American Mathematical Society, 2001.
- [140] H. Nakamura, L. Schneps, *On a subgroup of the Grothendieck-Teichmüller group acting on the tower of profinite Teichmüller modular groups*. Invent. Math. 141 (2000), 503560.
- [141] F. Patras, *Homothéties simpliciales*. Thèse de Doctorat, Université Paris 7, 1992.
- [142] ———, *La décomposition en poids des algèbres de Hopf*. Ann. Inst. Fourier. 43 (1993), 1067–1087.
- [143] D. Quillen, *Homotopical algebra*. Lecture Notes in Mathematics 43, Springer-Verlag, 1967.
- [144] ———, *The geometric realization of a Kan fibration is a Serre fibration*. Proc. Amer. Math. Soc. 19 (1968), 1499–1500.
- [145] ———, *Rational homotopy theory*. Ann. of Math. 90 (1969), 205–295.
- [146] C. Reutenauer, *Theorem of Poincaré-Birkhoff-Witt, logarithm, and representations of the symmetric group whose orders are the Stirling numbers*, in “Combinatoire énumérative”. Lecture Notes in Math. 1234, Springer-Verlag (1986), 267–284.
- [147] C. Reutenauer, *Free Lie algebras*. London Mathematical Society Monographs 7, Oxford University Press, 1993.
- [148] C. Rezk, *Spaces of algebra structures and cohomology of operads*. PhD Thesis, Massachusetts Institute of Technology, 1996.
- [149] P. Salvatore, *Configuration spaces with summable labels*, in “Cohomological methods in homotopy theory”. Progr. Math. 196, Birkhäuser (2001), 375–395.
- [150] P. Salvatore, N. Wahl, *Framed discs operads and Batalin-Vilkovisky algebras*. Q. J. Math. 54 (2003), 213–231.
- [151] H. Schubert, *Kategorien I, II*. Heidelberger Taschenbücher 65-66, Springer-Verlag, 1970.
- [152] J.-P. Serre, *Arbres, amalgames, SL_2* . Astérisque 46, Société Mathématique de France, 1977.
- [153] P. Ševera, T. Willwacher, *Equivalence of formalities of the little discs operad*. Duke Math. J. 160 (2011), 175–206.
- [154] S. Shnider, S. Sternberg, *Quantum groups. From coalgebras to Drinfel’d algebras. A guided tour*. Graduate Texts in Mathematical Physics, II. International Press, 1993.
- [155] D. Sinha, *Manifold-theoretic compactifications of configuration spaces*. Selecta Math. 10 (2004), 391–428.
- [156] D. Sinha, *Operads and knot spaces*. J. Amer. Math. Soc. 19 (2006), 461–486.
- [157] ———, *The topology of spaces of knots: cosimplicial models*. Amer. J. Math. 131 (2009), 945–980.
- [158] ———, *The homology of the little disks operad*, in “Operads 2009”. Séminaires et Congrès 26, Société Mathématique de France (2011), 255–281.

- [159] V. Smirnov, *On the chain complex of an iterated loop space*. Izv. Akad. Nauk SSSR Ser. Mat. 53 (1989), 1108–1119, 1135–1136. Translation in Math. USSR-Izv. 35 (1990), 445–455.
- [160] J.H. Smith, *Simplicial group models for $\Omega^n \Sigma^n X$* . Israel J. Math. 66 (1989), 330–350.
- [161] E. Spanier, *Algebraic topology (corrected reprint of the 1966 original)*. Springer-Verlag, 1981.
- [162] M. Spitzweck, *Operads, Algebras and Modules in General Model Categories*. Preprint [arXiv:math.AT/0101102](https://arxiv.org/abs/math/0101102) (2001).
- [163] J. Stasheff, *Homotopy associativity of H -spaces. I, II*. Trans. Amer. Math. Soc. 108 (1963), 275–292 and 293–312.
- [164] N.E. Steenrod, *Cohomology operations. Lectures by N.E. Steenrod written and revised by D.B. Epstein*. Annals of Mathematics Studies 50, Princeton University Press, 1962.
- [165] A. Strom, *The homotopy category is a homotopy category*. Arch. Math. 23 (1972), 435–441.
- [166] D. Sullivan, *Infinitesimal computations in topology*. Publ. Math. Inst. Hautes Études Sci. 47 (1977), 269–331.
- [167] M. Sweedler, *Hopf algebras*. Mathematics Lecture Note Series, W. A. Benjamin, 1969.
- [168] T. Szamuely, *Galois groups and fundamental groups*. Cambridge Studies in Advanced Mathematics 117, Cambridge University Press, 2009.
- [169] D. Tamarkin, *Another proof of M. Kontsevich formality theorem*. Preprint [arXiv:math.QA/9803025](https://arxiv.org/abs/math.QA/9803025) (1998).
- [170] ———, *Action of the Grothendieck-Teichmüller group on the operad of Gerstenhaber algebras*. Preprint [arXiv:math/0202039](https://arxiv.org/abs/math/0202039) (2002).
- [171] ———, *Formality of chain operad of little discs*. Lett. Math. Phys. 66 (2003), 65–72.
- [172] T. Terasoma, *Geometry of multiple zeta values, in “International Congress of Mathematicians. Vol. II (Madrid, 2006)”*. Eur. Math. Soc. (2006), 627–635.
- [173] T. Terasoma, *Multiple zeta values and mixed Tate motives*. Inv. Math. 149 (2002), 339–369.
- [174] G. Teschl, *Ordinary differential equations and dynamical systems*. Graduate Studies in Mathematics 140, American Mathematical Society, 2012.
- [175] V. Voevodsky, *Triangulated categories of motives over a field, in “Cycles, transfer and motivic homology theories”*. Ann. of Math. Studies 143, Princeton University Press (2000), 188–238.
- [176] C. Weibel, *An introduction to homological algebra*. Cambridge studies in advanced mathematics 38, Cambridge University Press, 1994.
- [177] G.W. Whitehead, *Elements of homotopy theory*. Graduate Texts in Mathematics 61, Springer-Verlag, 1978.
- [178] D. Wigner, *An identity in the free Lie algebra*. Proc. Amer. Math. Soc. 106 (1989), 639–640.
- [179] T. Willwacher, *M. Kontsevich’s graph complex and the Grothendieck-Teichmüller Lie algebra*. Preprint [arXiv:math/1009.1654](https://arxiv.org/abs/math/1009.1654) (2010).
- [180] M. Xicoténcatl, *The Lie algebra of the pure braid group*. Bol. Soc. Mat. Mexicana 6 (2000), 55–62.

- [181] Wenbin Zhang, *Group Operads and Homotopy Theory*. Preprint arXiv:1111.7090 (2011).