

# PERFORMANCE ANALYSIS OF EDFA FOR SCM/WDM RADIO OVER FIBER COMMUNICATION LINK

Arief Marwanto, Sevia M. Idrus, and Abu Sahmah Mohd. Supa'at  
Photonic Technology Centre, Faculty of Electrical Engineering,  
Universiti Teknologi Malaysia

## ABSTRACT

The radio-over-fiber (RoF) system is one of the potential schemes for the future broadband wireless communication systems such as mobile communications, hotspots and suburban areas. In this paper, we present 16 channels of RF carrier modulation of the Sub Carrier Multiplexing (SCM), which then integrated, with Wavelength Division Multiplexing (WDM) for the Radio over Fibre Link. The integration of the two systems is responding to the demands for high data rate applications and reasonable mobility for broadband communication. The work also investigates the performance of EDFA for the optical fiber length up to 200km. The EDFA introduced as the optical amplifier in the designed system model to encounter the effects of attenuation, distortion and Rayleigh scattering. The deploying of RF carrier performs by double side band and single side band of the SCM for bandwidth utilization shown to be much better than conventional optical WDM. However, by applying EDFA with the length varies from 0m – 5m, the performance show that total power transmission has magnifying the optical signal significantly and the optical fiber length expanded to 150 km. The simulation result has shown that pre-amplifier EDFA in 150km of SCM/WDM RoF system significantly boost the performance of optical signal strength over the link.

## INTRODUCTION

The increases of bandwidth demand are linear with the supply of networked services in many cellular operators. The network are setup to provide the user the services that are requires large bandwidth in the traffic, the services such as video streaming, data communication, push email, teleconference, mobile banking, etc. Therefore, the needs of broadband consumption of a user are increases. In order to supply the needs of bandwidth, many researchers currently actively investigate and focuses on three main components; spectrum allocation

of the frequency band, efficiency and to increase the capacity of the cell. In this work we propose Sub-Carrier Multiplexing (SCM) that complemented with Wavelength Division Multiplexing (WDM) to be introduced for the RoF. Thus, the combinations of SCM/WDM expected to supply the demand of bandwidth increases for the cellular communication. The shortcoming of cell distribution in cellular communication is limitation in bandwidth, range and spectrum allocation in order to maintain high quality of delivered signal among Mobile Switching Centre (MSC) to Base Station Controller's (BSCs) or Base Transceiver System (BTS). Radio over fiber techniques offered to optimize the limitation range and bandwidth provided. In order to overcome the losses and attenuation of the traveled signal, we introduce Erbium Doped Fiber Amplifier (EDFA) in SCM/WDM RoF system for over 150km – 200km of optical fiber link.

## SCM/WDM SYSTEM FOR ROF SYSTEM MODEL

The oldest method of signal distribution for the mobile application between the Mobile Switching Centre (MSC) and Base Station (BS) was using cooper cabling and microwave radio for data transceiver. In a system the spectrum allocation and bandwidth are required highest power, low data rate, highest attenuation and highly losses is not sufficient to overall the traffic demand by end-users.

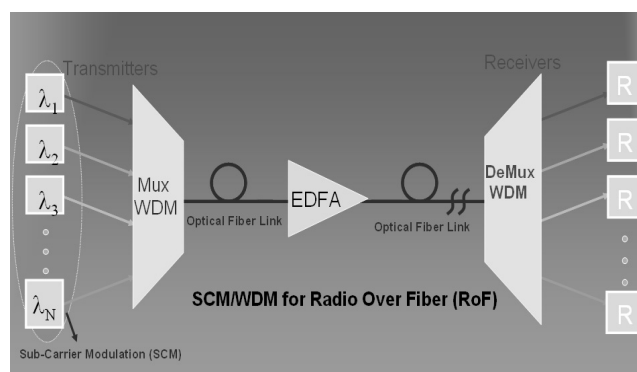

Figure 1 The SCM/WDM RoF with EDFA Communication Link System

The SCM/WDM for RoF system architectures comprises of two main systems that can found in Figure 1: (a) SCM/WDM transmitter, (b) SCM/WDM Receiver. The SCM/WDM for RoF link configurations are digitized the RF signals. However on the CS, RF signal is down-converted to the IF band and the signal digitized before modulated and directly transmitted to the BSs through the fiber. At the BS, the modulated signal detected by the Photodetector (PD) and converted back to analogue IF signal before up-converted to the desired RF band and transmitted to mobile hosts.

Table 1 The parameter of the SCM/WDM RoF communication Link with EDFA

| Parameter                    | Value         |
|------------------------------|---------------|
| Duplexing                    | SDD           |
| RF Modulation                | BPSK          |
| Optical Modulation           | MZM           |
| Channel BW                   | 1.8 GHz       |
| Bit Rate/Sub-Carrier Channel | 1.8 Gbps      |
| Sample /bit                  | 64            |
| Sequence Length              | 128 bits      |
| Fiber Length                 | 1 km – 150 km |

#### (a) SCM/WDM FOR RoF TRANSMITTER SYSTEM

The system architecture comprises of 2 block of RF module that generate of 8 Binary Phase Shift Keying (BPSK) in different frequency channel which is the width among the channels is 1.8 GHz In the SCM/WDM, the RF transmitter parts consists of 2x8 channels RF modulated which modulated in single wavelength. BPSK are introducing as RF carrier modulator on system architecture furthermore 1.8 Gbps bit rate are setup. CW Laser and MZM Modulator carried the RF modulated data in 1550 nm single wavelength. For this experiment, we take two sample of SCM channel consisting of 2x8 channels that carried digital data generates by Pseudo Random Bit Sequence (PRBS). Each of the data will be modulated by BPSK modulator with varies number of subcarrier which was in gigahertz.

One subcarrier may carry digital data, while another might modulated with an analogue signal such as video or telephone traffic. The composite electrical signal that has generated by the electrical transmitter that was amplified to 10 dB by an electrical amplifier and transform to optical domain through external optical modulator, MZM and CW laser applied as the optical source.

The Wavelength Division Multiplexing (WDM) was setup for multiplexing a single wavelength in order to transmit through SMF optical link. Two port channel setup for two link SCM channels for multiplexing in single wavelength. The WDM was installed to multiplexing optical signal carrier to the link; the basic operation of the WDM is several base band-modulated channels are transmitted along a single fiber but with each channel located at a different wavelength.

In the optical link distance varies between 20 km up to 150 km for long distance communication it's refers to

the low cost distance and resources efficient. The scenarios for optical amplifier can be setup in preamplifier and post-amplifier, pre-amplifier applied before WDM Mux and post amplifier assigned after WDM Mux in link of optical fiber.

The optical amplifier, EDFA was utilized in this design to amplified signal power with the fiber length are varied between 2 m up to 5 m. The EDFA is a length of glass fiber that has doped with the rare-earth metal Erbium ions. These ions act as an active medium with the potential to experience inversion of carriers and emit spontaneous and stimulated emission light near a desirable signal wavelength. The pump is typically another light source whose wavelength is preferentially absorbed by the ions, 0.98 or 1.48  $\mu\text{m}$  for EDFA. The pump and signal (1.55  $\mu\text{m}$ ) must combined, typically by a wavelength-selective coupler (WDM), and may co- or counter-propagate with respect to each other inside the doped length of fiber. Therefore, the light is absorbed by the doped fiber at a certain pump wavelength and then produce gain for a signal at a different wavelength. Since the transmission and the active medium are both fiber based, the insertion losses are minimal.

The propose SCM/WDM system was model and simulate to verify design using a commercial optical system simulator by Optiwave . The setup parameter for the EDFA can be found in Table 2, while the fiber optic specifications for signal distribution are listed in Table 3.

Table 2 The EDFA Parameter

| Parameters             | Value                             |
|------------------------|-----------------------------------|
| Core radius            | 2.2 $\mu\text{m}$                 |
| Er doping radius       | 2.2 $\mu\text{m}$                 |
| Er metastable lifetime | 10 ms                             |
| Numerical aperture     | 0.24                              |
| Er ion density         | $1 \times 10^{25} \text{ m}^{-3}$ |
| Loss at 1550 nm        | 0.1 dB/km                         |
| Forward pump power     | 100 mW                            |
| Backward pump power    | 0 mW                              |
| Length                 | 0 m – 5 m                         |

Table 3 Parameter setup for SMF Optic

| Parameters           | Value                        |
|----------------------|------------------------------|
| Reference Wavelength | 1550 nm                      |
| Length               | 1 km – 150 km                |
| Attenuation          | 0.2 dB/km                    |
| Dispersion           | 16.75 ps/nm/km               |
| Dispersion Slope     | 0.075 ps/nm <sup>2</sup> /km |

#### (b) SCM/WDM FOR RoF RECEIVER SYSTEM

After transmitted through a high-bandwidth optical fiber, the combined optical signals must demultiplexed at the receiving end by distributing the total optical power to each output port and then requiring that each receiver selectively recover only one wavelength by using a tunable optical filter. At the receiver, the received optical signal will be demultiplex by WDM Demux and converts

into electrical signal by a high speed APD photodetector. In this work an ideal WDM Demux was installed as function as optical signal demultiplexer. It works as optical filtering that compress, split, and filtering desired optical signals. The desired received signals are then selected through a Band Pass Rectangle filter, which split into individual SCM channel frequency. One of the main parameters that is in the top priority to sustain system quality is the photodetector sensitivity, which determines the minimum light power could be detected by the photodetector. This parameter determines the length of a fiber-optic link imposed by a power limitation. The more sensitive the photodiode, the longer the link can afford.

## RESULT AND ANALYSIS

In the optical communication link, power is one of the components that used to transmit optical signal. Through the fiber link, naturally power drops due to attenuation, distortion and losses. In this work the proposed system was successfully modeled and simulated, the results will illustrate the effect of using EDFA or without EDFA. The distance link was set up for 100 km and 150 km to evaluate how total power and EDFA have an effect to the link. In this paper we initiate the power is 0 W for 100km and 0 dBm for 150km

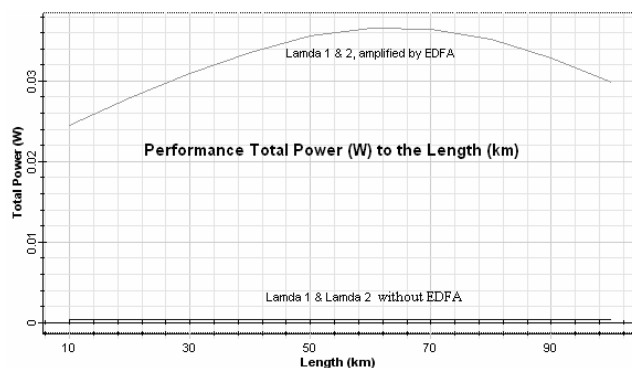

Fig. 2 The performance of SCM/WDM RoF with and without EDFA for 100km

Figure 2 and 3 illustrates the performance of total power to the length with and without EDFA. Figure 2 shows that EDFA can influence the total power to the link distance 100 km, where significantly increases 0.025 Watt to 0.037 Watt. In other hand, the total power also increases to the level of -20 dBm for the distance link of 150 km as shown in Figure 3. It means that the power reduced or attenuated over the link without EDFA. The slope of  $\lambda_1$  and  $\lambda_2$  began from 90km has decreased, down to the below level of -40 dBm, it indicates the implication of high frequency carrier are used affect to the quality of the power signal. These affect also happen when the signal traveled over the fiber link, it's reduced linearly in line of the distance. The limitation can overcome with the choosing quality of the optical fiber, light source, frequency carrier and EDFA parameters itself. However, EDFA is able to boost the total power that travel over the SMF fiber optic in the SCM/WDM RoF.

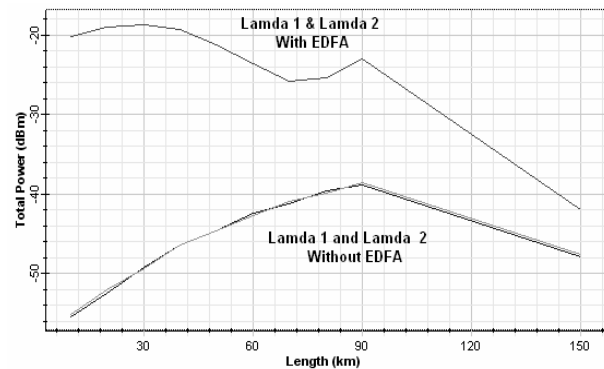

Fig. 3 The performance of SCM/WDM RoF with and without EDFA for 150km

However, EDFA model in the SCM/WDM RoF can be proposed for optical cellular and distance extended up to 200km. Therefore, the EDFA system model works to augment total powers that travel over the fiber link and significantly increases is much better than without EDFA. Finally, EDFA is able to support the SCM/WDM RoF system model to maintain the bandwidth provide optical cellular communication link.

For better results in future works, the values of EDFA applied varying the range of 10m – 20m to obtain the better gain of optical signals. Moreover, the simulation can be done in other commercial software such as Matlab to compare and tune the desired results of EDFA.

## CONCLUSION

Optical cellular communication systems require signal guarantee that capable to overcome distortion and attenuation in the communication link. The expected system has shown can reduce and minimize the losses until the total power maintained. Hence, the signal quality improved by utilizing EDFA for 100km and 150km of SMF for the SCM/WDM RoF with significantly increases the total power and minimize the losses. The system simulation with 0m – 5m length EDFA has verified that technique capable to boost up to power quality of the optical signal. EDFA is proficient to maintain the signal power augmented more than 50% of the initial power.

## REFERENCES

- Marwanto, Arief, M. Idrus, Sevia and A. Suryani, "The SCM/WDM System Model for radio over Fiber Communication Link", *2008 IEEE International RF and Microwave Conference* December 2-4, 2008, Kuala Lumpur, Malaysia pp. 400 – 403, 2008.
- Marwanto, Arief, and M. Idrus, Sevia, "Broadband Radio over Fiber communication Employing SCM/WDM System", *International Conference on ICT Technology*, 14 – 15 April 2008, Semarang, Indonesia, 2008
- N. Mohamed, M. Idrus, Sevia and Mohammad, A.B, "Review on System Architectures for the Millimeter-Wave Generation Techniques for RoF Communication Link", *2008 IEEE International RF and Microwave Conference* December 2-4, 2008, Kuala Lumpur,

Malaysia pp. 126 – 130, 2008.

H. Harun, S. M. Idrus, and A. B. Mohammad, "Optical Frontend Receiver Design for Radio over Fiber System", 5<sup>th</sup> Student Conference on Research and Development (SCORED) 2007, 11-12 Dec. 2007.

L. Noël, D. Wake, L.D. Westbrook, and etc al., 'Novel techniques for high-capacity 60 GHz fiber-radio transmission systems', *IEEE Trans. MTT*, v45 n8, p1416-1423, 1997.

D. Wake, M. Webster, G. Wimpenny, and etc al., 'Radio Over Fiber For Mobile Communications', *Microwave Photonics 2004*, pp. 157-160, 4-6 Oct. 2004.

J.J. O'Reilly, P.M. Lane, R. Heidemann, and R. Hofstetter, "Optical generation of very narrow linewidth millimeter wave signals," *Electron. Lett.*, vol. 28, pp. 2309 – 2311, 1995.

D. Novak, Z. Ahmed, R.B. Waterhouse, and R. S. Tucker, "Signal generation using pulsed semiconductor lasers for application in millimeter-wave wireless links," *IEEE Trans. Microwave Theory Tech.*, vol. 43, pp. 2257 – 2262, 1995.

R. Hui, Benyuan Z, Renxiang H., C. T. Allen, Kenneth R.D, and Douglas R. "Subcarrier Multiplexing for High-Speed Optical Transmission", *Journal of Lightwave Technology*, Vol. 20, NO. 3, March 2002.

C. Loyez, C. Lethien, R. Kassi, J.P. Vilcot, D. Decoster, N. Rolland and P.A. Rolland "Subcarrier radio signal transmission over multimode fibre for 60 GHz WLAN using a phase noise cancellation technique" *Electronics Letters* 20th January 2005 Vol. 41 No. 2 "

K. Kitayama, T. Kuri, H. Yokoyama, and M. Okuno, "60 GHz millimeter-wave generation and transport using stabilized mode-locked laser diode with optical frequency DEMUX switch," *IEEE Globecom'96*, vol. 3, pp. 2162 – 2169, Nov. 1996.



**Arief Marwanto** received the M.E. (2008), degree in Electrical Engineering from Universiti Teknologi Malaysia, and currently pursue his Ph.D in communication engineering at the Universiti Teknologi Malaysia. His current interests include Radio over Fiber, MIMO, OFDM, Wireless, and Optical Communication.



**Sevia M. Idrus** is the Deputy Director of the Photonics Technology Centre, Universiti Teknologi Malaysia. She received B.E.E and M.Eng. both from the UTM. She obtained her PhD in Optical Communication System from University Of Warwick in 2004. Her main research areas are optoelectronic devices, radio over fiber system, optical transceiver design and optical wireless communication.



**Abu Sahmah Mohd. Supa'at** is Associate Professor and Head of Telematic and Optic Engineering Department, Faculty of Electrical Eng. UTM. He received B.E.E and M.E.Eng both from UTM. He received his PhD degree from UTM in 2004. His present research are primarily concerned with the photonics switching, free space optic, optical sensor and integrated optical device fabrications and characterization.

# MILLIMETER WAVES GENERATION USING STIMULATED BRILLOUIN SCATTERING

Norizan M. Nawawi and Sevia M. Idrus

Photonic Technology Centre, Faculty of Electrical Engineering,  
Universiti Teknologi Malaysia

**ABSTRACT** The millimeter-wave (mm-wave) range has the highest potential for future data carrier because it is currently uncluttered and can support high data bandwidth. To ease system complexity in such systems there is growing interest in the exploitation of photonic technologies for the distribution of the mm-waves from a central station to a number of base stations via optical fiber links known as fiber-based wireless access scheme using radio-over-fiber (RoF) technology. Several techniques have been proposed for the optical generation of mm-waves such as direct modulation, external modulation, optical heterodyning and so on. However, in this work we proposed and investigate an alternative to above mention methods, which is based on Stimulated Brillouin Scattering (SBS) in an optical fiber. SBS technique was designed and modeled by performing CW laser in a single mode optical fiber (SMF) through optical Mach-Zehnder modulator (MZM) with two pump lasers for amplification purposes. The analysis was done by determination of the generated power depletion. SBS performance with the optical fiber loop length up to 100km was analyzed. It has been shown that SBS power is depends on the fiber loop length which is higher and lower at certain length due to natural properties of the fiber. The simulated design system has shown that the RF carrier generation can be achieved up to 40 GHz.

## 1. INTRODUCTION

Over the past decade there has been substantial progress in the areas of wireless and optical communications. The driving force behind this advancement has been the growing demand for multimedia services, and hence broadband access. Present consumers are no longer interested in the underlying technology; they simply need reliable and cost effective communication systems that can support anytime, anywhere, any media they want. As a result, broadband radio links will become more prevalent in today's communication systems. Furthermore, new

wireless subscribers are signing up at an increasing rate demanding more capacity while the radio spectrum is limited. To satisfy this increasing demand, the high capacity of optical networks should be integrated with the flexibility of radio networks. This leads us to the discussion on the fiber-based wireless access scheme using RoF technology.

RoF is an hybrid system that having both a fiber optic link and free-space radio path. Such system is important in a number of applications, including mobile communications, wireless local area networks (LANs), and wireless local loop, etc. However, the growing demand for higher data rates in wireless communication systems requires new frequency bands. RoF system has attracted considerable attention to deliver microwave and millimeter wave signals. It is a system that distributes the radio waveform directly from CS to BS through optical fiber (X. N. Fernando and S. Z. Pinter, 2005). There are some techniques have been proposed for the optical generation of mm-waves, (Lin Chen, Hong Wen, and Shuangchun Wen, 2006). One of the simplest methods is the modulation of continuous-wave (CW) laser light by an external modulator is expensive and there are several problems with the group velocity dispersion of the optical transmission systems. Other methods rely on the optical transport of modulated carriers at intermediate frequencies and optical heterodyne techniques. For the first method the mm-wave signal is generated by upconversion in the base station. This requires a high-quality local oscillator or an optically-supported phase-locked loop in the base station. The second method suffers from phase differences between the two superimposed optical signals. To overcome this phenomenon rather complicated setups have been proposed by (T. Schneider, M. Junker and D. Hannover, 2004).

In a RoF link, laser light is modulated by a radio signal and transported over an optical fiber medium. The laser modulation is analog since the radio-frequency carrier signal is an analog signal. The modulation may occur at the radio signal frequency or at some intermediate frequency if frequency conversion is utilized. The basic configuration of an analog fiber optic link

consists of a bi-directional interface containing the analog laser transmitter and photodiode receiver located at a base station or remote antenna unit, paired with an analog laser transmitter and photodiode receiver located at a radio processing unit. One or more optical fibers connect the remote antenna unit to the central processing location.

ROF systems of nowadays, are designed to perform added radio-system functionalities besides transportation and mobility functions. These functions include data modulation, signal processing, and frequency conversion (up and down) (Gliese U., Nielsen T. N., Norskov S., and Stubkjaer K. E., 1998; and Fuster J. M., Marti J., Candelas P., Martinez F.J., Sempere L., 2001).

For a multifunctional ROF system, the required electrical signal at the input of the ROF system depends on the ROF technology and the functionality desired. The electrical signal may be baseband data, modulated IF, or the actual modulated RF signal to be distributed. The electrical signal is used to modulate the optical source. The resulting optical signal is then carried over the optical fiber link to the remote station. Here, the data is converted back into electrical form by the photodetector. The generated electrical signal must meet the specifications required by the wireless application be it GSM, UMTS, wireless LAN or other.

## 2. STIMULATED BRILLOUIN SCATTERING

SBS stands for *Stimulated Brillouin Scattering* and it is a natural problem for high laser power in long fibers. If there is high laser power with a narrow linewidth along the fiber, the SBS effect causes much light to be reflected. This limits the power that can be transmitted and makes the signal noisy. Therefore SBS is an issue for optical transmitters in optical networks and for instruments that test components or systems with long fibers. Such tests can include measuring the power budget of an amplified or unamplified transmission span, or testing Raman amplifier configurations. Fibers exhibiting SBS at power levels of interest to telecommunications are usually at least several kilometers in length, but this depends on the type of fiber.

The origin of SBS lies in the backscattering of signal light by acoustic waves in the optical material, which is weak in short fibers. The backscattered light is shifted to lower optical frequency (higher wavelength) by the Brillouin-shift frequency, which depends on the fiber material. For common single-mode silica fiber, the shift is about 11 GHz (0.09 nm at 1550 nm). The backscattered light in a fiber can then stimulate more of the forward traveling light to be backscattered. When there is enough signal power, the backscattered light can gain more power by this stimulated backscattering than it loses due to fiber attenuation. When the fiber is long enough, the backscattered power keeps increasing along the fiber in an avalanche like process and can take most of the input optical power.

### 2.1 Principle of SBS

SBS is a nonlinear effect due to the amount of light

backscattered and the amount of light transmitted by the fiber does not depend linearly on the power input to the fiber. At low input powers the backscattering is dominated by simple Brillouin and Rayleigh scattering which are linear and differ from each other by the Brillouin shift. But as the power is increased, the Brillouin scattered light is increasingly amplified by the stimulation process. At a power level called the *SBS* threshold, the amount of backscattered light increases very rapidly with increasing input power until it constitutes most of the input light. The transmitted power at the fiber output saturates at a level that barely increases with increased input power. For single-mode fiber, SMF, of lengths above 10 km, the SBS threshold can lie in the range of 6 - 10 dBm. Above this threshold, the insertion loss of the fiber is not independent of input power.

### 2.2 SBS System Model

Figure 1 illustrates the system block diagram of SBS technique developed in this project. The technique was designed and modeled by performing CW laser in a single mode optical fiber (SMF) through optical Mach-Zehnder modulator (MZM) with two pump lasers for amplification purposes. MZM is nonlinear modulator that capable for generation of sidebands. These sidebands will be amplified by SBS in a fiber loop, whereas the rest will be attenuated due to natural attenuation in the fiber. Electrical generator was used to drive the MZM at certain frequency carrier. Circulator has been selected to circulate the signal from coupler and the output signal of SBS fiber loop. The amplified sidebands are then superimposed in PIN-photodiode which is the easiest way to generate mm-wave.

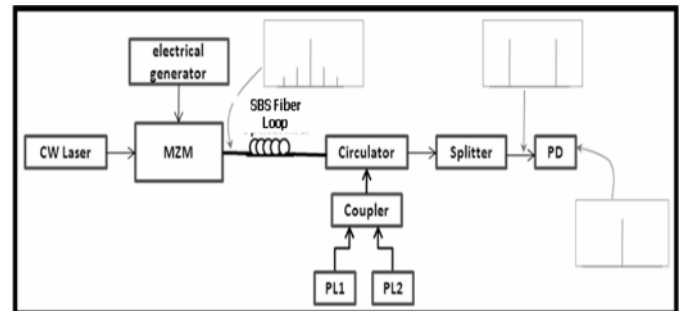

Fig. 1 Propose SBS System Block Diagram

#### 2.2.1 Central Station

The CS consists of optical modulator and SBS generator. Optical modulator can be any type of modulator as long as it can generate the harmonics that separated by frequency carrier. It means that we can use an arbitrary of laser and electrical generator. However, in this particular project, we stated to investigate the design using the CW laser and an intensity modulator (IM).

#### 2.2.2 Optical Modulator

The optical modulator consists of a CW laser, an

intensity modulator (IM), an electrical drive signal operating at a frequency,  $f_{sw}$ , and the data to be transported. The drive signal is used to sweep the optical frequency of the CW laser resulting in a peak-to-peak optical frequency deviation. To generate an un-modulated microwave or millimeter-wave carrier at the BS, this swept optical signal is fed directly into the SBS fiber loop. Otherwise, the swept optical signal is fed into an IM such as the Mach Zehnder Modulator (MZM), where it is intensity modulated before being distributed by the fiber network. In this case, the signal laser directly generates sidebands of the modulation signal due to its nonlinear characteristic line. These sidebands can be amplified by the SBS in optical fiber.

### 2.2.3 SBS Generator

The output of optical modulator is fed into the SBS generator where the SBS amplifications and up-conversions were occurred. Pump lasers were used to amplify the selected sidebands produced by MZM by control the frequencies of these pump lasers. The three ports circulator will circulate the signal from port 1 (output from the coupler) into the port 2, and the signal from port 2 into port 3. Using ideal circulator, we can control the insertion loss to be zero and there is no return loss or ideal isolation. The two frequency components from the output of circulator are then be superimposed in photodiode which is one of the easiest way for generating mm-waves.

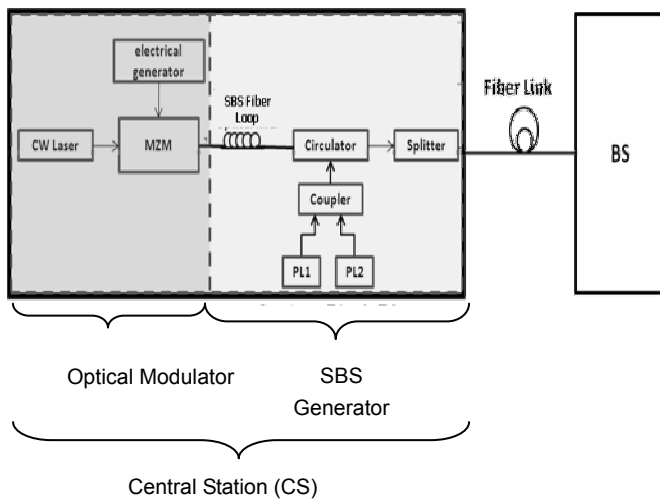

Fig. 2 SBS System Integrated With ROF Link.

## 3. RESULTS AND DISCUSSION

The generation of mm-waves for RoF system using SBS technique shown in Figure 1 was model and simulated using a commercial optical system simulator by Optiwave. The MZM is driven by the electrical sine generator in analog domain working with a fixed frequency;  $f_{RF} = 10$  GHz. A 0.5 dBm light wave emitted from continuous wave (CW) laser at 1550 nm from a

narrowband linewidth of 1 MHz is modulated by MZM. The voltage that is applied on the MZM is high enough so that the laser wave is modulated nonlinearly with the frequency of the electrical generator. Several optical sidebands separated by  $f_{RF}$  from the optical carrier are generated by MZM nonlinearity. These signals are injected into up to 100 km long of standard single mode optical fiber (SSMF) loop.

The pump source generates a combined output signal of two pump lasers. This pump source is injected into SSMF via an optical circulator and propagates at the opposite direction of the modulated signals. The wavelength of each pump laser is adjusted in the manner of 11GHz higher than one of the frequencies in the modulated signal. The power of signal wave is controlled by an EDFA. SBS relies on the generation of sidebands of CW laser by nonlinear modulation these two sidebands will be amplified by SBS in an optical fiber, whereas the rest will be attenuated due to natural attenuation in the fiber. The millimeter-wave band output signal is detected by a photodiode (PD).

The frequency of the millimeter-wave depends on the RF of the electrical generator and on the sidebands that were chosen for amplification. The generated millimeter-wave has the frequency of  $f_{mm} = 2nf$ , with  $n$  as the number of the sideband used and  $f$  as the RF of the electrical generator. With  $f = 10$  GHz, millimeter-waves with frequencies of 20, 40, 60, . . . GHz are possible. If the frequency of the generator is  $f = 5$  GHz, output frequencies of 10, 20, 30, . . . GHz can be produced, and so on.

Figure 3 presents the signals pattern of the first and second stokes with 10 GHz modulation at 0.5 dBm light wave for 50 km SSMF loop length, measured after PD in time domain. Oscilloscope visualizer was used to display the time plot of the generated electrical signal. Bandpass rectangular filter (BPF) is used to centre of the desired stoke components results in electrical signals of regular intensity patterns. It is clear that the only difference between signal patterns at 20 GHz and 40 GHz (apart from frequency) is the amplitude (a.u). The amplitude of higher stokes was decreased from 4 mV to about 350 $\mu$ m. This confirms that apart from the fundamental frequency, the higher order stokes may also be used to transmit data.

RF 20 GHz (Rectangular BPF 1.5\*Bit Bate Hz)

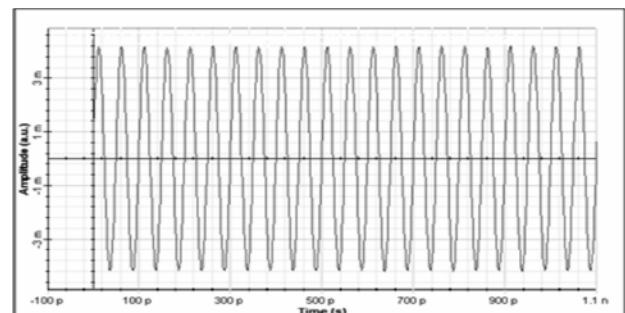

(a)

RF 40 GHz (Rectangular BPF 1.5\*Bit Bate Hz)

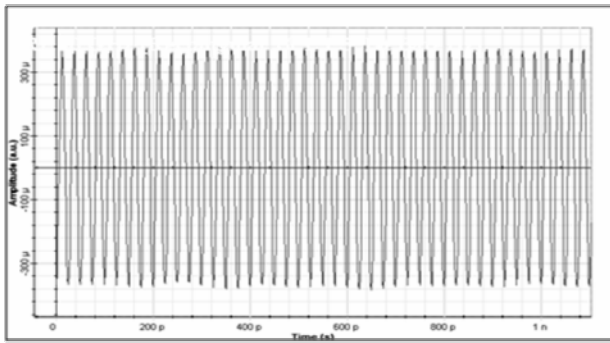

(b)

Fig. 3 The signals pattern with 10 GHz modulation at 0.5 dBm light wave for 50 km SSMF loop length. (a) The 20 GHz bandpass filtered electrical signal in time domain; (b) The 40 GHz bandpass filtered electrical signal in time domain.

Figure 4 represents the performance analysis when varies the SSMF loop length within range 1 km until 100km with optical amplifier. In term of power intensities, the amplifier was boosted up the power up to 0dBm at 20km for the first stoke. As can be seen, the first stokes has higher intensity compared to second stoke. It also shows that the SBS effect was started occur at 10 km and then will degraded the power intensities in longer fiber.

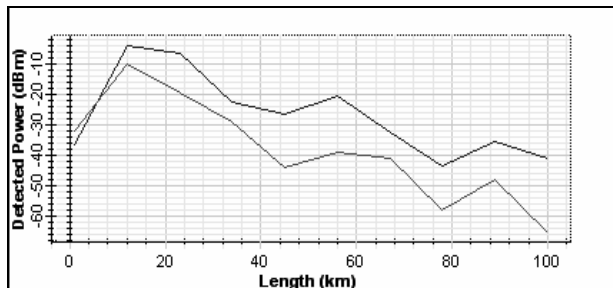

Fig 4 Comparing intensities of first and second stokes generated by sine generator with amplifier.

## CONCLUSION

Stimulated Brillouin Scattering (SBS) is a nonlinear effect in an optical fiber due to the amount of light backscattered, and the amount of light transmitted by the fiber, does not depend linearly on the power input to the fiber. In this paper, SBS is used as a method for the tunable generation of mm-waves for RoF. We have demonstrated the generation of mm-waves for RoF system using SBS in SSMF. The proposed technique is necessary for any electrical generator frequency other than 10 GHz. Simulation results have demonstrated that the designed SBS technique for RoF system has a potential to generate high mm-waves. A 0.5 dBm of light wave is carried by 10 GHz RF signal were successfully generated up to 40 GHz millimeter-wave band corresponding to the 2<sup>nd</sup> stokes. Test the design using an arbitrary wave generator for optimum power performance may be a future work for this paper.

## REFERENCES

- X. N. Fernando and S. Z. Pinter, "Radio over Fiber for Broadband Wireless Access", *Department of Electrical and Computer Engineering, Ryerson University, Toronto, Canada*, 2005.
- Lin Chen, Hong Wen, and Shuangchun Wen, "A Radio-Over-Fiber System with a Novel Scheme for Millimeter-Wave Generation and Wavelength Reuse for Up-Link Connection" *IEEE Photonics Technology Letters*, Vol. 18, No. 19, October 1, 2006.
- T. Schneider, M. Junker and D. Hannover, "Generation of millimetre-wave signals by stimulated Brillouin scattering for radio over fibre systems", Vol. 40, Nov. 2004.
- Gliese U., Nielsen T. N., Norskov S., and Stubkjaer K. E. ; "Multifunction Fibre-Optic Microwave Links Based on Remote Heterodyne Detection"; *IEEE Trans. On Microwave theory and Techniques*, Vol. 46, No. 5, May 1998.
- Fuster J. M., Marti J., Candelas P., Martinez F.J., Sempere L., "Optical Generation of Electrical Modulation Formats", in *Proceedings of the 27th European Conference on Optical Communication 2001 (ECOC'01)*, Amsterdam, Sept. 30 - Oct. 4, 2001, pp 536-537.
- Stephen Z. Pinter and Xavier N. Fernand, "Fiber-Wireless Solution for Broadband Multimedia Access", *IEEE Canadian Review - Summer 2005*, pp. 6-9, 2005.



**Norizan M. Nawawi** received B.E.E. and M.E.E. both from UTM in 2007 and 2008 respectively. She joint Universiti Malaysia Perlis as a lecturer in July 2008. Her main research area is related to optical fiber communication technology.



**Sevia M. Idrus** is the Deputy Director of the Photonics Technology Centre, Universiti Teknologi Malaysia. She received B.E.E and M.Eng. both from the UTM. She obtained her PhD in Optical Communication System from University Of Warwick in 2004. Her main research areas are optoelectronic devices, radio over fiber system, optical transceiver design and optical wireless communication.



# ISSUES OF SPECTRUM SENSING IN COGNITIVE RADIO BASED SYSTEMS

Rozeha A Rashid, Norsheila Fisal  
Telematic and Optic Department, Faculty of Electrical Engineering,  
Universiti Teknologi Malaysia  
[rozeha@fke.utm.my](mailto:rozeha@fke.utm.my), [sheila@fke.utm.my](mailto:sheila@fke.utm.my)

## ABSTRACT

Cognitive radio (CR) is a promising technology to overcome the insufficiency of available communication spectrums. Such radios are able to sense the spectral environment and use this information to opportunistically provide wireless links that meet the user communications requirements optimally. To achieve the goal of cognitive radio, it is a fundamental requirement that the cognitive user (CU) performs spectrum sensing to detect the presence of the primary user (PU) signal before a spectrum is accessed to avoid interference from other wireless users. In this paper, three local spectrum sensing (LSS) methods, namely matched filtering, energy detection and PU signal feature cyclo-stationary based detection will be discussed. The discussion will highlight the methods' strengths and weaknesses, the parameters concerned and their feasibilities to CR-based overlay and underlay technologies. Cross layer functionalities related to spectrum sensing will also be presented. Shadowing and multipath at various locations can degrade the sensing mechanism of an LSS detector. To address this issue, *cooperative spectrum sensing technique* is investigated where several LSS detectors of CR-assisted systems can be coordinated to perform spectrum sensing cooperatively to gather channel information for better sensing reliability.

## 1. INTRODUCTION

The limited available spectrum and the inefficiency in the spectrum usage necessitate a new communication paradigm to exploit the existing wireless spectrum opportunistically. A recent spectrum occupancy measurement (Fig. 1) shows that a significant portion of the spectrum allocated to licensed services show little usage over time, with concentration on certain portions of the spectrum while a significant amount of the spectrum remains unutilized (Akyildiz, et al., 2006). Spectrum utilization can be significantly improved by adopting the concept of Dynamic Spectrum Access (DSA) where unlicensed or cognitive users (CUs) can temporarily utilize unoccupied bands but need to be sufficiently agile to vacate the space (time, frequency or spatial) once the licensed or primary users (PUs) are detected as not to

cause harmful interference.

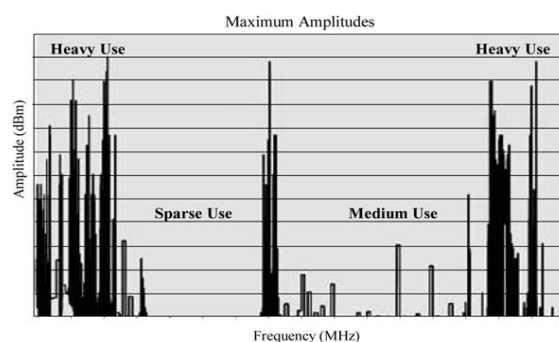

Fig. 1 Spectrum Utilization

Ultra-wideband (UWB) and cognitive radio (CR) are two exciting technologies that offer new approaches to spectrum usage. UWB is an underlay approach with restrictions on transmitted power levels; thus promotes coexistence with other existing radio technologies and operates over ultra wide bandwidth. While CR employs overlay approach based on avoidance of primary users by using spectrum sensing and adaptive allocations.

Originally introduced by Mitola, (2000), CRs are capable of sensing their environment, learning about their radio resources and user/application requirements, and adapting behavior by optimizing their own performance in response to user requests (Haykin, 2005). Researches in CR are mainly evolved around the following technical issues in enabling spectrum-aware communication protocols (H. Shiang & M. Schaar, 2008):

- How to sense spectrum and model the behaviour of the PUs.
- How to manage and decide the available spectrum to meet user QoS requirements. These management functions involve spectrum analysis and spectrum decision.
- How to share the available spectrum resources fairly.
- How to maintain seamless communication during transition (handoff) of selected frequency channels.

UWB is another promising technology for future short and medium range wireless communication networks with a variety of throughput options including very high data rates. Federal Communication Commission (FCC) in its report in 2002 authorized the unlicensed use of UWB in 3.1-10.6 GHz and has

restricted the minimum occupied bandwidth of each mono/multi band(s) to 500 MHz. Furthermore, it defined a spectral mask that specifies the power level radiated by UWB systems within this band to be near the thermal noise floor (-41.3 dBm/MHz). The low power level makes UWB an attractive solution in WPAN multimedia applications as well as CR technology. It allows UWB to coexist harmoniously to share the spectrum with existing technologies such as 5 GHz-U-NII bands without causing harmful interference by turning off UWB transmission on the occupied frequency bands. Thus, the incorporation of CR feature of spectrum sensing is vital to locate spectrum holes, observe present users' activities and eventually avoid interference when transmitting. This hybrid technology, named Cognitive UWB (CUWB) is expected to exploit advantages of both CR and UWB for efficient spectrum resource management.

Furthermore, multiband orthogonal frequency division multiplexing (MB-OFDM) based UWB seems to be more attractive to CR technology due to the following characteristics (Rozeha, et al., 2008):

- a) In MB-OFDM, subcarriers that are overlapped with PU can be turned off which results in flexible data rate.
- b) Several users can coexist in the same temporal and spectral domain by assigning different Time-Frequency Code (TFC) which indirectly also provides information security.
- c) Many of existing wireless standards such as IEEE802.11a/g WLAN, IEEE802.16 WIMAX and IEEE802.22 3GPP are based on OFDM technology. Hence, it offers seamless communications and interoperability among various wireless devices.

This paper is divided into five sections. Section 2 presents a review of well known spectrum sensing techniques, namely, matched filter, energy detector and cyclostationary feature detection. Section 3 presents the cross layer design of spectrum sensing and its intended functionalities. The principle of cooperative spectrum sensing is introduced in Section 4. Finally, open research challenges in spectrum sensing are discussed in Section 5.

## 2. SPECTRUM SENSING

To achieve the goal of CR, it is a fundamental requirement that the cognitive user performs spectrum sensing to detect the presence of PU signal. The spectrum sensing is often considered as a detection issue where the CUs have to scan a vast range of frequencies to observe available spectrum 'white spaces' or 'holes' that are temporarily and spatially out of service. The goal of spectrum sensing is to decide between the following two hypotheses (Akyildiz, et al., 2006):

$H_0$  : Primary user is absent

$H_1$  : Primary user is present.

In order to avoid harmful interference to the primary system, the sensing time should be carefully chosen. If the sensing time is too long, a PU may enter the band at which a CU is operating in and causes interference. In addition, lengthening the sensing time may result in missing chances for using the spectrum when a PU has

left a band while the CU is still waiting for the sensing time to be elapsed. There are three aspects of PU detection that need to be verified and quantified in order to define metrics for CR systems (Rozeha, et al., 2008):

- a) The time until detection of the PU.
- b) The time needed to clear the spectrum once a PU has been detected.
- c) The reliability of PU detection; the probability of missed detection,  $P_{MD}$  and the probability of false alarms,  $P_{FA}$ .

If the detector mistakes  $H_0$  for  $H_1$ , a false alarm occurs, and a spectrum opportunity is overlooked by the detector. On the other hand, when the detector mistakes  $H_1$  for  $H_0$ , we have a miss detection, which potentially leads to a collision with PUs.

In general, CU sensitivity should outperform PU receiver by a large margin in order to prevent what is essentially a *hidden terminal problem*. This margin is required because CU does not have a direct measurement of a channel between primary user receiver and transmitter and must base its decision on its local channel measurement to a primary user transmitter. This type of detection is referred to as *local spectrum sensing* (LSS) and the worst case hidden terminal problem would occur when the CU is shadowed, in severe multipath fading, or inside buildings with high penetration loss.

LSS detector can be a matched filter, an energy detector, or a cyclostationary feature detector (Cabric, 2004), (Cabric, 2006). In this section, the advantages and disadvantages of each technique will be discussed.

### 2.1 MATCHED FILTER

The optimal way for any signal detection is a matched filter (MF), since it maximizes received signal-to-noise ratio (SNR). Due to its coherency, less time is required to achieve high processing gain since the number of samples required for optimal detection is  $O(1/\text{SNR})$  (A. Sahai, et al., 2004). However, it requires a prior knowledge on the behavior (modulation) of the received signal. Hence, detecting different signals requires implementing several MFs.

### 2.2 ENERGY DETECTOR

The energy detector (ED) arises as a suboptimal choice for non-coherent detection using an estimated threshold (A.A. El-Saleh, et al., 2008). The ED requires no knowledge on the channel signals but a small error in estimating the hypothesis's threshold may result in an unreliable detection of PUs. Thus, the ED would completely fail in low SNR environments. Furthermore, the ED does not differentiate between modulated signals and noise. The number of samples required to optimally detect the incoming signal is  $O(1/\text{SNR}^2)$  (A. Sahai, et al., 2004).

### 2.3 CYCLOSTATIONARY FEATURE DETECTOR

The cyclostationary feature detector (CFD) discriminates the modulated signals from the noise. CFD implements a two-dimensional spectral correlation function (SCF) rather than the one-dimensional power spectral density (PSD) of the energy detector to reliably extract the spectral correlation due to the periodicity

feature of modulated signals from the noise that is of a wide-sense stationary (WSS) and no correlation (A.A. El-Saleh, et al., 2008). The main drawback for the feature detector is the increased complexity. Table 1 summarizes the strengths and weaknesses of each spectrum sensing techniques mentioned above.

Table 1 Advantages and Disadvantages of Spectrum Sensing Techniques

| Spectrum Sensing Technique | Advantages  | Disadvantages   |
|----------------------------|---|---|
| ED                         | Does not need prior information<br>Low computational cost | Cannot work in low SNR<br>Cannot distinguish users sharing the same channel |
| MF                         | Optimal detection performance<br>Low computational cost   | Requires synchronization and a prior knowledge of the PU                    |
| CFD                        | Robust in low SNR<br>Robust to interference               | Requires partial information of PU<br>High computational cost               |

The feasibilities of each technique for overlay and underlay modes are also studied. Due to MF requirement of *priori* knowledge of the received signal and hence the need for several MFs to detect different signals makes it impractical approach for overlay system. However in underlay, it may be feasible by detecting the adjacent CU nodes using its preamble pattern as suggested in the proposed novel active sensing model by Qi. Liu et al. (2008). In the case of ED, due to its poor performance in low SNR environments, it is inconvenient to be utilized for the underlay CUWB which is mostly of low SNR (as it is so close to the noise floor level). However, it can be carefully used for the high-power overlay CR. Meanwhile, CFD can be considered as a strong candidate for both overlay CR and underlay CR-UWB technologies due to its capability of differentiating noise energy from the modulated signal energy.

### 3. CROSS LAYER DESIGN IN SPECTRUM SENSING

Cabric, et al. (2004) have proposed a cross design approach for spectrum sensing. This is to improve the CR sensitivity by enhancing radio frequency (RF) front-end sensitivity, exploiting digital signal processing gain for specific PU signal and network cooperation where CUs share their spectrum sensing measurements. The physical (PHY) and medium access control (MAC) layers' functions that are linked to spectrum sensing are considered. This is illustrated in Fig. 2.

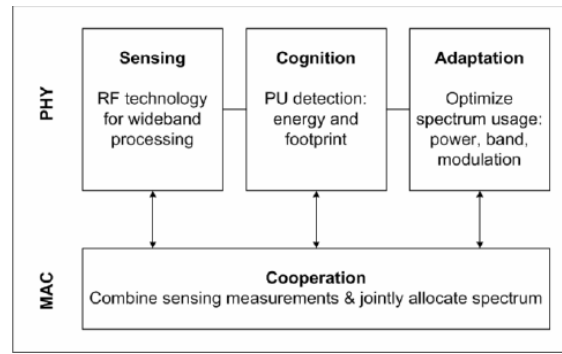

Fig. 2 Cross layer functionalities related to spectrum sensing

### 4. COOPERATIVE SPECTRUM SENSING

There exist several open research challenges that need to be investigated for the development of the spectrum sensing function for underlay UWB. Because of the low emission power, its communication range is shorter than sensing range. Problems like hidden terminal, shadowing and fading environments may cause the miss detection if the existing active LSS methods are deployed. So these approaches are not proper for CUWB. Several recent works have shown that cooperative spectrum sensing can greatly increase the probability of detection in fading channels (A. Ghasemi & E. S. Sousa, 2005). Multiple CUs can be coordinated to perform spectrum sensing cooperatively and the sensing information exchanged between neighbors is expected to have a better chance of detecting PU compared to individual sensing.

A cooperative network of several CR-assisted systems can be modeled as an OR-rule network (A.A. El-Saleh, et al., 2008). The cooperation scheme used can be centralized or distributed. Work by R.W Brodersen, et al. (2004) has proposed a centralized scheme where an access point collects sensing results from all users. It then sounds the channel and performs channel allocation that meets the requested data rates of each user. In the distributed cooperation scheme as proposed by Cabric, et al. (2004), neighbors are chosen randomly. Although the implementation maybe easier, it does not achieve the capacity that of centralized scheme. A generic model of cooperative sensing is depicted in Fig. 3.

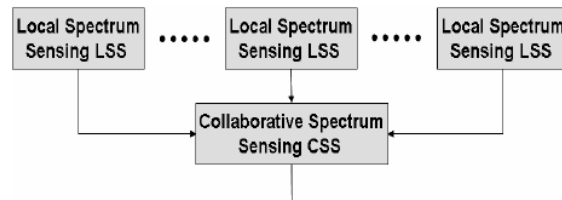

Fig. 3 Generic model of cooperative/ collaborative spectrum sensing

### 5. SPECTRUM SENSING CHALLENGES

The challenge of spectrum sensing in multi-user networks is raised in (Akyildiz, et al., 2006). Cooperative spectrum sensing technique can be utilized to exploit the multiuser diversity and independent fading channels (G. Ganesan & Y.G. Li, 2005). However, the remaining challenge in cooperation is combining the results of various users which may have different sensitivities and sensing times. A weighted combining method in (Lee, W. & Cho, D. H., 2008) is performed to take the differences into account. The need for control channel in cooperation, which can be either implemented as a dedicated frequency channel or as underlay UWB channel and overhead associated with sensing information exchange remain significant challenges.

Another challenge in spectrum sensing is developing an interference detection model by effectively measuring the interference temperature. In UWB, the spectrum sensing feature of the CR plays a role on the interference avoidance using various narrowband interference avoidance methods as described in (H. Arslan & M.E. Sahin, 2006).

One of the main requirements of cognitive networks is the detection of the PUs in a very short time (Akyildiz, et al., 2006). MB-OFDM has been introduced as a strong candidate to be the platform for underlay CR\_UWB (A. Batra, S. Lingam & J. Balakrishnan, 2006). Since multi-carrier sensing can be exploited in OFDM-based cognitive networks, the overall sensing time can be reduced. Once a primary user is detected in a single carrier, sensing in other carriers is not necessary. In (H. Tang, 2005), a power-based sensing algorithm in OFDM networks is proposed for detecting the presence of a PU. It is shown that the overall detection time is reduced by collecting information from each carrier. However, this necessitates the use of a large number of carriers, which increases the design complexity. Hence, novel spectrum sensing algorithms need to be developed such that the number of samples needed to detect the primary user is minimized within a given detection error probability.

## CONCLUSION

Recent advances in technology have shown that Ultra-Wideband (UWB) and cognitive radio (CR) are two stimulating technologies that offer novel approaches to the spectrum usage. Hybrid technology, CUWB provides an ultimate spectrum aware communication paradigm in wireless communication. The discussion in this paper provides an overview of the spectrum sensing schemes for CR based systems. From the comparison, CFD seems to be the best detector for both overlay and underlay modes. A cross layer design established for spectrum sensing is also presented. Open research challenges in spectrum sensing are also discussed to facilitate further investigation for the development of spectrum sensing function.

## REFERENCES

Akyildiz, I.F, et. al, NeXt Generation/Dynamic

Spectrum Access/Cognitive Radio Wireless Networks: A Survey, *Computer Networks*, 50, 2127–2159, Elsevier, 2006

A.A. El-Saleh, M. Ismail, O. B. A. Ghafoor, A. H. Ibrahim, Comparison Between Overlay Cognitive Radio And Underlay Cognitive Ultra Wideband Radio For Wireless Communications, *Proc. Of 5th IASTED Int'l Conf. Communication and Networks (AsiaCSN2008)*, Langkawi, Malaysia, 2-4 April 2008

A. Batra, S. Lingam, J. Balakrishnan, 'Multi-band OFDM: A cognitive radio for UWB', *Proceeding IEEE Int'l Symposium on Circuits and Systems*, May 2006

H. Tang, Some physical layer issues of wide-band cognitive radio system, *Proc. IEEE DySPAN*, pp. 151–159, November 2005

A. Ghasemi and E. S. Sousa, Collaborative Spectrum Sensing for Opportunistic Spectrum Access in Fading Environment, *Proc. IEEE DySPAN*, Nov 2005

A. Sahai, N. Hoven, R. Tandra, Some Fundamental Limits on Cognitive Radio, *Proc. of Allerton Conference*, Monticello, 2004

Cabric, D., Mishra, S.M., Brodersen, R.W., Implementation Issues in spectrum sensing for cognitive radios, *Asilomar Conference on Signals, Systems and Computers*, 2004

Cabric, D., O'Donnell, I. D., Chen, M.S., Brodersen, R.W., Spectrum Sharing Radios, *IEEE Circuits and Systems Magazine*, 2nd Quarter 2006

FCC Spectrum Policy Task Force, "Report of the spectrum efficiency working group," Nov 2002. [Online] <http://www.fcc.gov/sptf/reports.html>

G. Ganesan, Y.G. Li, Agility improvement through cooperative diversity in cognitive radio networks, *Proc. GLOBECOM*, pp. 2505-2509, Nov 2005

Haykin, S., Cognitive Radio: Brain Empowered Wireless Communication, *IEEE Journal on Selected Areas in Communication*, 23(2), 201-220, 2005

H. Arslan and M.E. Sahin, *Ultra Wideband Wireless Comm. on Narrowband Interference Issues in Ultrawideband System*, Hoboken, NJ: Wiley, Sept 2006

H. Shiang & M. Schaar, Queing-Based Dynamic Channel Selection for Heterogeneous Multimedia Applications Over Cognitive Radio Networks, *IEEE Transactions on Multimedia*, 2008

Lee, W., Cho, D.H., Sensing Optimization Considering Sensing Capability of Cognitive Terminal in Cognitive Radio System, *Proceeding CROWNCOM*, 2008

Mitola III, J, Cognitive: Radio an integrated agent architecture for software defined radio, Ph.D thesis, KTH Royal Institute of Technology, Stockholm, Sweden, 2000.

Qi Liu and et al, A Novel Active Spectrum Sensing Scheme for Cognitive MB-OFDM UWB Radio, *Proceeding CROWNCOM*, 2008

Rozeha A. Rashid, et al., Cross Layer Design of Cognitive Radio MB-OFDM System, *3rd International Conference on Postgraduate Education (ICPE3)*, Penang Dec 12 – 14 2008

R.W Brodersen, A. Wolisz, D. Cabric, S.M. Mishra, D. Wilkomm, 2004, White Paper: CORVUS – A Cognitive Approach for Usage of Virtual Unlicensed Spectrum, available online <http://www.bwrc.eecs.berkeley.edu/MCMA>



Rozeha A. Rashid received her B.Sc in Electrical Engineering from University of Michigan, Ann Arbor, USA and her M.E.E (Telecommunication) from Universiti Teknologi Malaysia (UTM). She is a senior lecturer in the Department of Telematic and Optic, Faculty of Electrical Engineering, UTM. She is currently pursuing her PhD in the area of Cognitive Radio. Her research interests include Wireless Sensor Network and Wireless Communication.



Norsheila Fisal received her B. Sc (Electronic Communication) from University of Salford, Manchester, U.K and her M. Sc. (Telecommunication Technology) and her PhD (Data Communication) from University of Aston, Birmingham, U.K. She is a Professor at the Department of Telematic and Optic, Faculty of Electrical Engineering, Universiti Teknologi Malaysia. Her current interests include Cognitive Radio, Software Defined Radio, Wireless Sensor Network, IPv6 and Ad-hoc Network.

# A TRIAL OF INTERACTIVE REMOTE TEACHING BY SHARED VIRTUAL SPACES BETWEEN TWO UNIVERSITIES

\*Michiko Ohkura, \*\*Hiroyuki Sakurai, and \*\*\*Tetsuro Aoto

\*Department of Information Science and Engineering, Shibaura Institute of Technology,

\*\*Faculty of Psychology, Risho University,

\*\*\*Graduate School of Engineering, Shibaura Institute of Technology

## ABSTRACT

An interactive remote teaching trial was performed by shared virtual space between two universities. Its features included the interactivity of teaching by faculty members of both universities, collaboration between information engineering and psychology, and the utilization of shared virtual space in education. This new and fruitful attempt received favorable evaluations from participating students.

## 1. INTRODUCTION

In 1999, the first author began both a lecture course and an exercise course on the design and development of information systems for third year students of the Department of Information Science and Engineering of the Shibaura Institute of Technology (SIT). These courses, which continue today, were designed based on *An Undergraduate and Professional Curriculum "J97" in Computer Science* (IPSJ, 1997). The special exercise course, which was intended to be practical from the beginning, has been revised by referencing curriculum guidelines by ACM/IEEE (ex. (ACM/IEEE-CS, 2001) (ACM, 2002)) (Ohkura et al., in press).

In 2006, another exercise course entitled the "Design and Implementation of Virtual Space" also began at SIT (Ohkura et al., 2008). Although various courses have attempted to utilize virtual reality such as (Fujiki et al., 2007) (Tomita et al., 2007), teaching design and implementation of virtual space *en masse* is not so common.

On the other hand, the second author, who belongs to the Faculty of Psychology at Risho University (RU), continues to research the

"Psychology of Virtual Reality" aiming at power assist of kansei and/or intelligent activities. He has employed virtual reality for "Utilizing plan of research activities" of the "Risho University Cyber Campus Network Project."

Since both universities have facilities for real-time transfer of images and sounds and for remote VR transfers, we performed the following interactive remote teaching trial by shared virtual spaces:

- (1) The Faculty of Engineering students taking the exercise course entitled the "Design and Implementation of Virtual Space" showed and explained their own virtual space navigations.
- (2) The Faculty of Psychology students listened to the explanations while viewing the virtual space stereoscopically and evaluated the virtual spaces by questionnaires.
- (3) The above processes were repeated for other virtual spaces one by one.
- (4) The questionnaire results were analyzed at RU and explained in remote-teaching lectures.

This is the report of the remote teaching trial.

## 2. OUTLINE OF EXERCISE COURSE

Before describing the remote teaching trial, the outline of the exercise course entitled the "Design and Implementation of Virtual Space" will be described.

This exercise is held in conjunction with other exercises by two other professors for juniors in fall semester. The students choose two out of three exercises for the first half and the latter half. The curriculum shown in Table 1, which is designed for two periods/week of

half the semester, assumes that the students have taken exercise courses in programming and algorithms using C language.

Virtual Reality Modeling Language (VRML) generates objects in virtual spaces. Since VRML description is text-based using tags, it is relatively easy to learn for students familiar with C language and html.

From the third class, students worked in groups and used VRML to generate objects and other software to construct virtual spaces. As software to construct virtual space, OmegaSpace of Solidray Co., Ltd. was employed.

At the 6th class, the students of each group introduced their constructed virtual spaces, which were displayed stereoscopically using a 100-inch screen and polarized glasses (Aoto et al., 2005). Moreover, students answered questionnaires to evaluate the exercise course, including the following question to get keywords used for later remote teaching: "Please list as many suitable adjectives and onomatopoeia as possible to evaluate the generated virtual spaces by yourselves or other students such as stiff or fuzzy."

Figures 1 and 2 show examples of virtual objects made by VRML and examples of virtual worlds constructed using OmegaSpace, respectively.

The following are the main features of this exercise course:

- Project-based learning
- Manufacturing
- Visualization

This exercise course was also introduced as an example of the OmegaSpace e-version, developed for educational usage (Solidray Co. Ltd.).

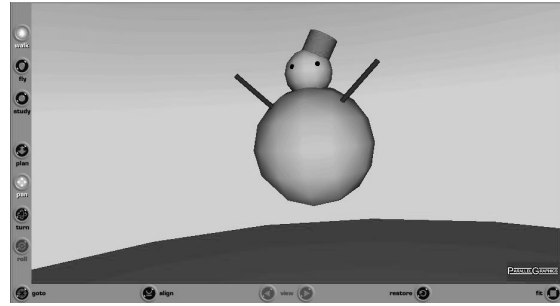

(a) Snowman

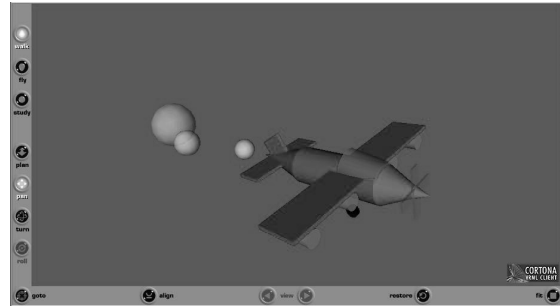

(b) Airplane

Fig. 1 Examples of objects made by VRML

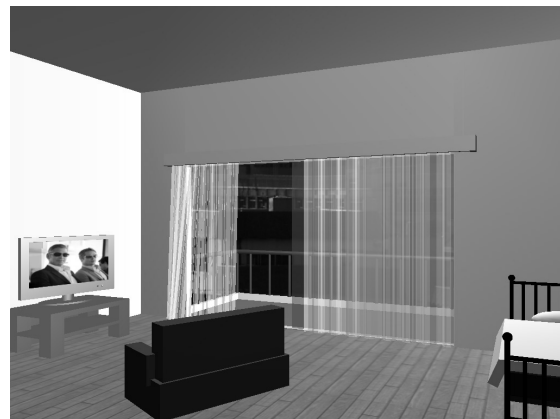

(a) Student's room



(b) Christmas in Toyland

Fig. 2 Examples of virtual spaces constructed using OmegaSpace

Table 1 Curriculum outline

| Class | Content   |
|-------|---|
| 1     | Explanation of VRML and exercises   |
| 2     | Presentation of VRML products   |
| 3     | Explanation of software to construct virtual spaces and deciding target spaces to generate for each group |
| 4     | Exercises to construct virtual spaces   |
| 5     | Exercises to construct virtual spaces   |
| 6     | Presentation of constructed virtual spaces  |

### 3. CONDUCTING REMOTE TEACHING

The interactive remote teaching trial using shared virtual spaces was conducted on January 9<sup>th</sup>, in 2008.

#### 3.1 Equipment

The following equipment was used at SIT:

- (1) TV meeting system (Polycom)
  - Communication rate: 1024kbps
  - Image sources: PC and camera images
  - Displays: 2 100-inch screens (one for PC images and another for camera images)
- (2) Software to share virtual space: OmegaSpace to shared spaces for many people

The RU equipment was almost identical.

#### 3.2. Content of remote teaching

- (1) Introduction of virtual spaces and their evaluations

Beforehand, the files of the virtual spaces constructed by the SIT students were sent to RU and installed on a PC. During remote teaching, after the same virtual space file was simultaneously boosted on OmegaSpace in both universities, the students/ creators of the virtual space operated a mouse and introduced the space. The mouse operations reflected the synchronized movements of the virtual space at RU: the realization of shared virtual space.

RU students with polarizing glasses watched the virtual space stereoscopically while listening to the introduction by the SIT students. After the introduction, they removed the polarizing glasses and answered questionnaires to evaluate the virtual space. Table 2 shows the employed evaluation items, which are based on an evaluation used by the second author (Sakurai et al, 1997) to which he added the keywords selected and modified from the questionnaire results answered by SIT students beforehand. Each item was evaluated on a 7-point Likert scale, where 7 implies “very” and 1 implies “not at all.”

The above introduction and evaluation process was repeated for seven different virtual spaces. Figure 3 shows remote teaching at an RU classroom, where students are watching a virtual space with polarizing glasses, and Fig. 4 shows a SIT classroom when the RU students answered questionnaires. The right screen showed a virtual space and the left screen showed the RU camera image.

Table 2 Items for impression evaluation

| Number | Keyword         | Number | Keyword            |
|--------|-----------------|--------|--------------------|
| 1      | Immersive       | 20     | Cool               |
| 2      | Easily viewable | 21     | Simple             |
| 3      | Interactive     | 22     | Intimate           |
| 4      | Familiar        | 23     | Nostalgic          |
| 5      | Useful          | 24     | Stick              |
| 6      | Enjoyable       | 25     | Stylish            |
| 7      | Intelligent     | 26     | Cut-and-try        |
| 8      | Free            | 27     | Quick              |
| 9      | Relieved        | 28     | Comical            |
| 10     | New             | 29     | Smooth             |
| 11     | Interesting     | 30     | Laid-back          |
| 12     | Unique          | 31     | Magical            |
| 13     | Motivational    | 32     | Careful            |
| 14     | Warm            | 33     | Invigorating       |
| 15     | Funny           | 34     | Exciting           |
| 16     | Avant-garde     | 35     | Kawaii             |
| 17     | Dynamic         | 36     | Dreamy             |
| 18     | Mechanistic     | 37     | Extraordinary      |
| 19     | Beautiful       | 38     | Soothing           |
|        |                 | 39     | Totally Preferable |



Fig. 3 Classroom scene at RU



Fig. 4 Classroom scene at SIT

- (2) Explanation of evaluation results

The questionnaire results were analyzed immediately by the second author. The analytical methods and results were explained during the remote teaching. First, the averaged scores were shown for each virtual space evaluated by five RU students. Then, all the results were shown, and the scores of items with relatively large differences between spaces were compared.



During lectures, the RU students explained their reasons of impression scores and the SIT students commented on them. Figure 5 shows all the results of the impression evaluations. Content (6) has relatively higher scores for items 20# (Cool) and 25# (Stylish), for example.

#### 4. DISCUSSION

By focusing on the information stream in interactive remote teaching this time, the information mainly traveled from SIT to RU by operating the virtual spaces in the first half of the lectures. On the other hand, in the later half, it mainly traveled from RU to SIT by explaining the data analysis. In general remote teaching, interactive questions and answers between a teacher and students at remote locations are common. However, the following features of our interactive remote teaching trial are not:

- Interactivity of main information stream to students of both universities
- Collaboration between information engineering and psychology
- Utilization of shared virtual space in education

Participating SIT students made the following comments:

- It was very interesting that the keywords I wrote were employed for impression evaluation and analysis.
- I was very happy that the sales points of our virtual space could be fully understood by students with different backgrounds.
- The analytical method lecture and the analysis results of the impression evaluations were very useful and interesting.

Moreover, participating RU students made the following comments:

- It was very interesting that the evaluation of the same content was different between its creator and observers.
- I thought it was very meaningful that our impressions were sent immediately and that we could get the reactions of the creators at once.

Based on such comments from both universities, through this remote teaching using shared virtual spaces, we successfully gave students of both universities a chance to communicate with students of different fields

and to increase their awareness of the value of collaboration.

#### 5. CONCLUSION

An interactive remote teaching trial was performed with shared virtual spaces between the Shibaura Institute of Technology and Rissho University. Its features included the interactivity of teaching by the faculty members of both universities, collaboration between information engineering and psychology, and the utilization of shared virtual space in education. This attempt received favorable evaluations from the participating students, suggesting that this remote teaching using shared virtual space is useful to promote communication between the students of different research fields. In other words, it effectively utilized shared virtual space to offer an important opportunity to exchange views for impression evaluations with other students with different research fields.

In this trial, the number of evaluators at Rissho University was only five, which is too few for detailed analysis. Greater detailed analysis based on another trial with a sufficient number of evaluators remains future work.

#### ACKNOWLEDGEMENTS

We received generous support from Prof. Yamashita of Rissho University, Mr. Moriya of NTT Communications, Mr. Samejima of Solidray, the Academic Information Center of the Shibaura Institute of Technology, and the Information Media Center of Rissho University.

#### REFERENCES

- ACM, *IS2002 Curriculum Guidelines for Undergraduate Degree Programs in Information Systems*, ACM, New York, 2002. <http://www1.acm.org/education/is2002.pdf>.
- ACM/IEEE-CS, *CC2001 Final Report of the Joint ACM/IEEE-CS Task Force on Computing Curricula 2001 for Computer Science*, ACM, New York, 2001. [http://acm.org/education/curric\\_vols/cc2001.pdf](http://acm.org/education/curric_vols/cc2001.pdf).
- Aoto, T., et al., Construction of Virtual Toyosu Campus Display System, *The Research Report of Shibaura Institute of Technology, Natural Sciences and Engineering*, vol. 49, no. 1, Shibaura Institute of Technology, Tokyo, pp. 11-18, 2005 (in Japanese).

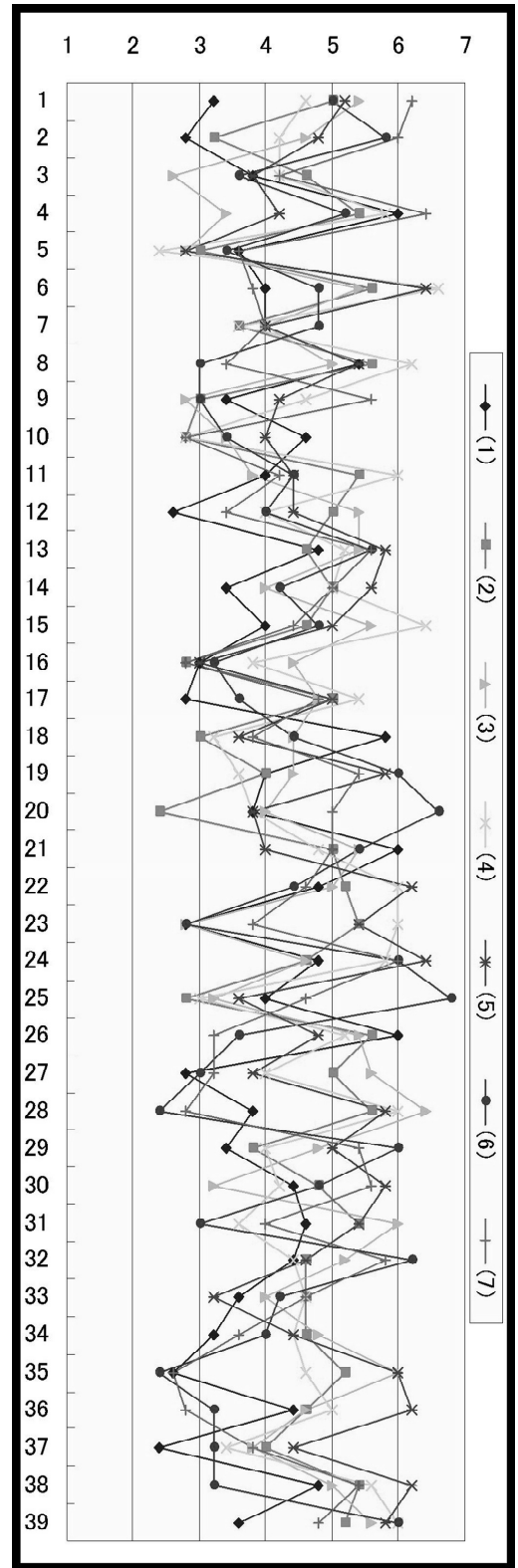
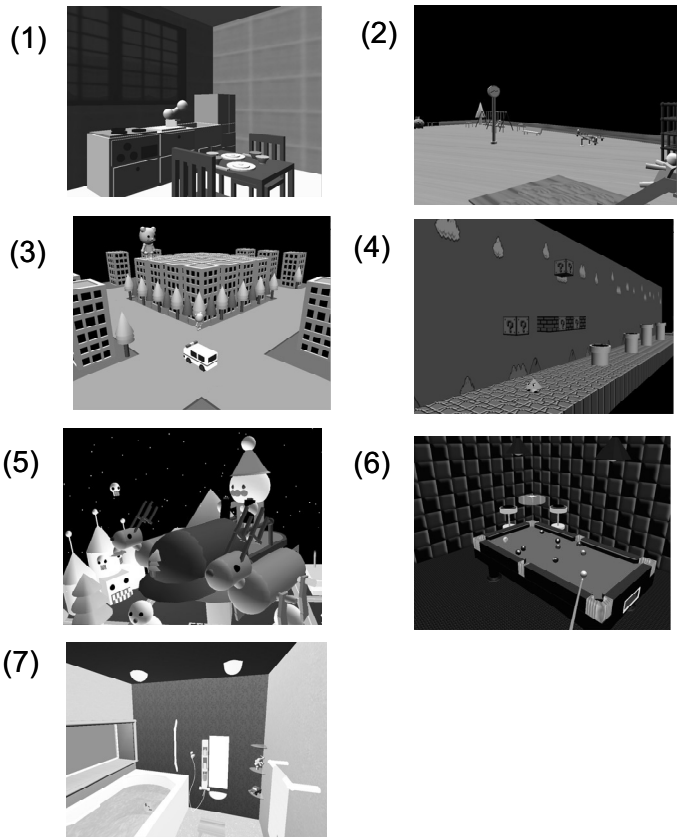

Fig. 5 Impression evaluation results

Fujiki T. et al., Development and Educational Usage of VR Learning Materials about Atomic Bomb, *IEICE Technical Report*, vol. 107, no. 391, IEICE, Tokyo, pp. 57-62, 2007 (in Japanese).

Information Processing Society of Japan (IPSJ), *An Undergraduate and Professional Curriculum "J97" in Computer Science*, Information Processing Society of Japan, Tokyo, 1997 (in Japanese).

Ohkura, M., Izumiya, A., and Aoto, T., Practice of project-based-learning exercise entitled Design and Implementation of Virtual Space, *IEICE Technical Report*, vol. 107, no. 536, IEICE, Tokyo, pp. 13-17, 2008. (in Japanese).

Ohkura, M., Aoto, T., and Kimura, M., Implementation and Assessment of Exercise for design and Development of Information Systems, *The Research Report of Shibaura Institute of Technology, Natural Sciences and Engineering*, Shibaura Institute of Technology, Tokyo, in press (in Japanese).

Sakurai, H., Sakumoto, K., and Sugimoto, M., Evaluation of Communication between Students using PC Conference System, *Proceedings of the 5<sup>th</sup> Joint Meeting of Societies for Educational Technology*, pp. 299-302, 1997 (in Japanese).

Solidray Co. Ltd., VR Software/Shibaura Institute of Technology,  
[http://www.solidray.co.jp/product/omega/c\\_version2.html](http://www.solidray.co.jp/product/omega/c_version2.html).

Tomita, T., et al., Interlude: VR Edutainment Materials for Elementary Dynamics Experiment, *IEICE Technical Report*, vol. 107, no. 391, IEICE, Tokyo, pp. 69-74, 2007 (in Japanese).



**Michiko Ohkura** received her B.S. (1976), M.S. (1978) in mathematical engineering and Ph. D (1995) in advanced interdisciplinary studies from the University of Tokyo.

She is a Professor of Department of Information Science and Engineering, Shibaura Institute of Technology. Her current research interests include interactive systems, Kansei information processing, and pharmaceutical interface.



**Hiroyuki Sakurai** received his Ph. D (2000) from Meisei University. He is an Associate Professor of Faculty of Psychology, Rissho University. His current interests include sensibility psychology and virtual reality psychology.



**Tetsuto Aoto** received his B.S. (2000) in industrial management and M.S. (2006) in information science and engineering from Shibaura Institute of Technology.

He is a Ph. D candidate at SIT. His current interests include Kansei value of interactive systems.