

# **Telemedicine Technical Assistance Documents**

## **A Guide to Getting Started in Telemedicine**

**Joseph Tracy, MS**

**University of Missouri – School of Medicine**

**Editor**

**Foreword by Dena Puskin, ScD**

**Office for the Advancement of Telehealth**



# **Contents**

---

**Acknowledgements ..... ii**

**Foreword..... iii**

## **Chapters:**

<b>1. Introduction .....</b>	<b>1</b>
<b>2. First Steps in Creating a Successful Telehealth Program .....</b>	<b>6</b>
<b>3. Cardiology .....</b>	<b>23</b>
<b>4. Dermatology .....</b>	<b>51</b>
<b>5. Disease Management .....</b>	<b>85</b>
<b>6. Electronic Medical Records for Rural Health Systems .....</b>	<b>108</b>
<b>7. HIV/AIDS .....</b>	<b>134</b>
<b>8. Home Care .....</b>	<b>151</b>
<b>9. Mental Health .....</b>	<b>188</b>
<b>10. Pharmacy .....</b>	<b>206</b>
<b>11. Rehabilitation .....</b>	<b>241</b>
<b>12. School-based Services .....</b>	<b>267</b>
<b>13. Telehealth Technology .....</b>	<b>314</b>
<b>14. Trauma and Emergency Care .....</b>	<b>343</b>

## **Appendices**

<b>A. Telehealth and Telecommunication Definitions .....</b>	<b>377</b>
<b>B. About the Authors – Biographies .....</b>	<b>384</b>

# Acknowledgements

The primary and contributing authors of this work would like to gratefully acknowledge the federal Office for the Advancement of Telehealth, Health Resources and Services Administration, U.S. Department of Health and Human Services for funding this work. This work was conducted under the following grants numbers:

6H2A TM 00056-01-00	Marshfield Medical Research and Education Foundation
4H2A TH 00051-07-07	Curators of the University of Missouri
6D1B TM 00025-02-01	Susquehanna Health System
4D1B TH 00646-01-04	University of Virginia
6H2A TM 00235-06-01	University of Tennessee - Knoxville
4H2A TH 00054-06-04	Deaconess Billings Clinic Foundation
1D1B TM 00051-01-03	North Dakota State University
5H2A TM 00245-06-00	Integrus Health
6H2A TM 00303-03-01	University of Kansas Medical Center
6D1B TM 00081-01-01	University of Vermont

## Foreword

The German philosopher Schopenhauer (1788-1860) wrote: "There are three steps in the revelation of any truth: first, it is ridiculed; in the second, resisted; in the third, it is considered self-evident." Telehealth technologies have followed a similar fate. In the late 1980s and early 1990s, many looked on these technologies as "vaporware." Even today, resistance to widespread deployment of the technologies persists. Its comes from many quarters, reflecting challenges that range from provider concerns about quality of service and reimbursement to difficulties in integrating the technologies into day-to-day health care practice. It is only when sufficient experience has been gained with the use of these technologies that this picture will begin to change. Nevertheless, the uses of videoconferencing and imaging technologies in different areas of health care are expanding rapidly, from classic clinical encounters, such as dermatology or behavioral health, to home health care and rehabilitation services.

Telehealth technologies, however, have not yet become "self-evident" in health care, that is, they have not become an integral part of mainstream health care. The challenges are significant, especially for community-based providers. Recognizing these challenges, 51 individuals came together to develop a basic document that would assist community-based providers in establishing a telehealth program. The result is the following document, which addresses 12 different applications of these technologies. The recommendations in each chapter are based on the real-life experiences of programs that often have been pioneers in the development of telehealth services for underserved communities. Given the rapid advances in telehealth technologies and the diversity of communities in the United States, the recommendations should be viewed as a starting point, not an end point, for implementing telehealth programs.

This document was produced by a group of telehealth service providers who gave their time and effort because of their belief in telehealth technologies as a facilitator for more cost-effective health care services. The dedication of the individuals involved in this project represents the spirit of collaboration that is so essential to the telehealth field if it is to succeed. A special word of appreciation is extended to Joe Tracy, Executive Director of Telehealth at the University of Missouri Health Care, for his leadership and persistence on this project, despite many other constraints on his time.

Finally, this document was funded under various grants awarded by the Office for the Advancement of Telehealth (OAT), Health Resources and Services Administration (HRSA), U.S. Department of Health and Human Services (DHHS). The views and opinions presented are those of the authors and various contributors to the chapters. They do not represent the official position of OAT, HRSA, or DHHS.

Dena S. Puskin, Sc.D.  
Director  
Office for the Advancement of Telehealth  
HIV/AIDS Bureau  
Health Resources and Services Administration  
U.S. Department of Health and Human Services

# Chapter One

---

## Introduction

**Author:** Joseph A. Tracy, MS, University of Missouri Health Care

### **Contributing Authors:**

Thelma McClosky Armstrong, Eastern Montana Telemedicine Network

Samuel Burgiss, PhD, University of Tennessee Graduate School of Medicine

Susan Dimmick, PhD, University of Tennessee Graduate School of Medicine

Karen Edison, MD, University of Missouri Health Care

Michael A. Ricci, MD, University of Vermont College of Medicine

Karen Rheuban, MD, University of Virginia Health System

Cynthia Scheideman-Miller, MHA, Integris Health

Richard J Settimo, MA Ed, University of Virginia Health System

Rob Sprang, MBA, University of Kentucky

Telehealth and telemedicine are becoming more and more engrained in the delivery of everyday healthcare, distance education and health care administration. Tens of thousands of patients in underserved areas are receiving services they may not have otherwise received without traveling great distances or overcoming other transportation barriers. The services provided via telemedicine range from primary care to the highly specialized care found in leading academic medical centers. Services are provided across the spectrum, from the youngest of patients to the frail elderly. Telehealth systems can be found in hospitals, clinics, nursing homes, rehabilitation hospitals, homes, assisted living facilities, schools, prisons, or health departments. In fact, today you may find telehealth systems any place healthcare is provided.

**Telemedicine** is the use of electronic communication and information technologies to provide or support clinical care at a distance<sup>1</sup>.

**Telehealth** is defined as the use of electronic information and telecommunications technologies to support long-distance clinical health care, patient and professional health-related education, public health and health administration<sup>2</sup>.

Over the past 10 years the technologies needed to provide healthcare services at a distance have vastly improved and drastically dropped in price; reimbursement for telehealth is more broadly available than it was 10 years ago; and the cost of telecommunication services in many areas is much lower thanks to competition and the Federal Communication Commission's Rural Health Care Support Mechanism (i.e., universal service fund), which provides discounts for telecommunications services provided by eligible rural healthcare facilities using telehealth technologies. These are just a few of the barriers that have been overcome, at least in part, to allow telehealth network expansion across the United States. The proliferation of telehealth programs has taught many lessons to those that have been engaged in telehealth activities since the early 90s. While this document focuses on telehealth delivery in underserved areas, the lessons learned apply to all communities.

There are as many ways to configure and develop a telehealth network, as there are specialties to provide the service. There is no "standard" model, nor is there one right or wrong way for designing a telehealth network to provide care.

The focus of this document is "telemedicine" as defined earlier or simply put the clinical application of providing care at a distance. The information contained within is designed to help those interested in entering the world of telehealth. It will give one a better understanding of the steps necessary to get started on their way to the development of a successful and sustainable telemedicine network.

Below is a listing of the various specialty areas that will be covered in this document. The primary authors of each section (listed in parentheses) are all grantees of OAT, with a proven track record of delivering telemedicine services. Each chapter is written from real world experiences. It should be noted that no attempt has been made to standardize the writing styles of the individual authors. As such, each chapter will have a slightly different tone and flow of information. A non-clinical chapter related to telehealth technologies is also included.

---

Cardiology (Nina Antoniotti, PhD & Michael Hillman, MD)  
Dermatology (Karen Edison, MD, Hon Pak, MD & Joe Tracy, MS)  
Disease State Management (Nina Antoniotti, PhD & Michael Hillman, MD)  
Electronic Medical Records for Rural Health Systems (Pamela Wirth)  
HIV/AIDS (Karen Rheuban, MD, Brian Wispelwey, MD & Richard J Settimo, MA Ed)  
Home Care (Samuel Burgiss, PhD and Susan Dimmick, PhD)  
Mental Health (Thelma McClosky Armstrong, MA)  
Rehabilitation (Cynthia Scheideman-Miller, MHA)  
School-based Services (Ryan Spaulding, PhD-C & Gary Doolittle, MD)  
Telehealth Technologies (Franklin D. Gannan, Richard Phillips, & Michael Patterson)  
Telepharmacy (Charles D. Peterson, Pharm.D. & Howard C. Anderson, Jr., R.Ph.)  
Trauma and Emergency Care (Michael A. Ricci, MD & Michael P. Caputo, Jr., MS)

It is also important to recognize that many other experienced telehealth professionals contributed to the writing of this document and their names appear in each respective section.

In the various chapters of this publication the reader will see references to specific manufacturers, vendors, and equipment. These references are made simply to indicate the equipment some programs are using or have used in the past. They are not an endorsement of any company or product.

Before researching and developing a telehealth or telemedicine program one must understand that telehealth is not about technology, it is about people. It is about how we can use technology to help improve the lives of individuals living in underserved areas of the country and the world. Telehealth does not create new medical services; it simply provides an alternative way to deliver existing services. In short, the goal is to make the technology transparent in the delivery of quality healthcare services.

### **Definitions:**

It is strongly recommended that the reader take time to thoroughly review the chapter on Telehealth and Telecommunication definitions. It provides terms that will help



anyone new to telehealth better understand this work. However, in addition to the definitions of telemedicine and telehealth which were provided earlier, there are two other terms that need to be described here. They are the terms “consultation” and “encounter”. They are often used interchangeably in the telehealth world but they mean very different things.

Before moving on to the actual terms, it is very important to note the distinction between a provider-to-provider discussion about a patient’s diagnosis or treatment, a “consultation” (sometimes called a “consult”) versus a direct patient “encounter” (visit) with a provider. Both “consult” and “encounter” are defined below.

*Consult:*

A telehealth consultation whereby a patient’s primary care provider consults with a specialist (consulting provider) at a distant site, but the care of the patient remains the responsibility of the patient’s primary care provider (the care of the patient never transfers to the consulting physician). The patient may or may not be present in real time for the consult.

Example: A general internal medicine physician discussing a patient’s cardiac condition with a cardiologist at the distant site. The general internist is free to act or not act upon the advice of the cardiologist.

*Encounter:*

An encounter is defined as telehealth event involving patient contact. This would include a patient being treated directly by a provider at the distant site, or cases involving the patient along with providers at both the distant and originating site.

Example: A patient seen directly by a specialist, who examines them, renders a diagnosis and who may order tests or prescriptions based on the diagnosis. The referring provider may or may not accompany the patient during an encounter. In this example the care of the patient is the direct responsibility of the specialist.

Unfortunately many individuals in telehealth still refer to all telehealth clinical activities

as “consults” or “consultations” when in actuality there are far more direct patient “encounters” with providers than provider-to-provider “consults”. As such the reader should be cautioned to always ask for clarification when telehealth clinical activities are being described as consults or consultations. The distinction becomes particularly important when discussing matters of cross-state licensure and reimbursement.

Reference:

1. 1997, Telemedicine Report to Congress, U.S. Department of Commerce, P.1.
2. 2001, Telemedicine Report to Congress, U.S. Department of Health and Human Services, P.13.

## Chapter Two

---

### **First Steps in Creating a Successful Telehealth Program**

**Author:** Joseph A. Tracy, MS, University of Missouri Health Care

#### **Contributing Authors:**

Thelma McClosky Armstrong, Eastern Montana Telemedicine Network

Samuel Burgiss, PhD, University of Tennessee Graduate School of Medicine

Susan Dimmick, PhD, University of Tennessee Graduate School of Medicine

Karen Edison, MD, University of Missouri Health Care

Michael A. Ricci, MD, University of Vermont College of Medicine

Karen Rheuban, MD, University of Virginia Health System

Cynthia Scheideman-Miller, MHA, Integris Health

Richard J Settimo, MA Ed, University of Virginia Health System

Rob Sprang, MBA, University of Kentucky

The contributing authors to this document agree that the following information must be obtained and understood before one should embark upon creating a telehealth program. This section deals with researching, planning and promoting the telehealth concept in an effort to obtain the level of institutional support necessary to cultivate a successful and sustainable program. This section will also discuss the various public and private policies that affect telehealth and offer the reader a list of references for staying abreast of changing policy issues.

#### **I. Creating a Telehealth Program within the Institution:**

The first step is to ascertain the degree to which a telehealth program either falls within the existing scope and mission of the institution or how such a program might beneficially expand its mission.

The second step is for one to develop a telehealth proposal for their institution to consider. This step requires several initial tasks:

1. Search the literature and the Web to get a full understanding and appreciation for what existing organizations are doing in telehealth. Several good Web sites include (listed in alphabetical order and last accessed on 6/8/04):
  - a. American Telemedicine Association – [www.americantelemed.org](http://www.americantelemed.org)
  - b. Association of Telemedicine Service Providers – [www.atasp.org](http://www.atasp.org)
  - c. Center for Telemedicine Law - <http://www.ctl.org/>
  - d. Federal Office for the Advancement of Telehealth - <http://telehealth.hrsa.gov/>
    - i. <http://telehealth.hrsa.gov/grants/grantee.htm> (Grantee Directory)
  - e. Telemedicine Information Exchange - <http://tie.telemed.org/>
2. Conduct a needs and demand analysis of telemedicine services the target population(s) may use. For example, a population may have a need for cardiology services in a rural community, but if the providers in that community are demanding it from another source or are demanding the service be provided in-person than promoting the service via telehealth will be difficult. In short, need and demand are mutually exclusive and both need to be considered before the implementation of any telehealth service.
3. Based on the literature review and the need/demand analysis develop an initial conservative estimate of what the program might cost and provide ideas on how it may be funded. Just make sure this estimate is clearly marked “DRAFT”.
4. Develop a succinct report and presentation based on the information gathered in the first two steps. Give that report and presentation to the clinical, executive, administrative, and educational visionaries in the institution and ask for support. Without this high-level of commitment, the program will not evolve and become an accepted component of the health care delivery model of the organization.

When one has received approval to move forward from the clinical, educational and administrative leaders of the institution it is imperative to do the following:

- Contact several existing telehealth programs that appear to be a good fit for the program being considered. It may take several calls to reach and schedule a phone conference for this purpose. The staff of many existing programs are typically very busy, but they will answer questions and provide information if they have scheduled an audio conference with another site. *Helpful Hint: Do not be afraid to contact a program located in the same State. Telehealth networks are growing and the technologies are converging and becoming ubiquitous. Networks within the state and throughout the country will soon be able to communicate seamlessly. The once stand alone telehealth network will be a thing of the past. As such it is important to collaborate early with those within the state, especially at a time when telehealth can be used as a tool for disaster preparedness and response.*
- Ask if a particular telehealth program would be kind enough to entertain a site visit from members of your organization. A site visit, if well planned, will provide a wealth of real world knowledge about telehealth. *Helpful Hints: (1) please be flexible in requesting such a visit as the hosting institution will be taking time and energy away from their daily activities to meet with you; (2) do not be surprised if the hosting institution charges for such visits; and (3) the visiting organization should send administrative, clinical and technical staff on the visit and make sure to allow time to visit with the respective peer groups at the hosting organization.*

Assuming that ample research and site visits have been made, it is time to further refine the program design to meet the institutional situation. One should:

- Refine the list of best telehealth services to be offer to the target audience (i.e., the general public) or under a contract with another organization (e.g., prisons, schools, military installations, etc). *Helpful Hint: Do not attempt to implement*

*more than two or three services at the beginning. It will stretch the human resources too thin and lead to unrealistic expectations in delivering the service.*

- Clearly define your measurable objectives for your telehealth service. Lay them out with clear timelines and the name of the party responsible for the objective.
- Refine the estimated costs to the institution and the partner sites.
  - How will the program sustain itself in the short and long run?
    - Consider that revenue generation is possible in certain areas (especially under contracts with partnering organizations such as correctional facilities, military bases, etc). Also consider that increased physician revenues may result from referrals received in new geographic markets normally inaccessible through standard in-person encounters.
    - Do not overlook that cost savings or cost avoidance may be possible. This includes savings associated with reduced travel for clinical outreach services or administrative travel (especially in vertically integrated networks).
  - If the program is to be considered a cost of doing business because of the value it adds to the institution this needs to be well documented.

It should be noted that estimating savings or revenue generation is not easy. For instance, some may argue that the revenue generation is insignificant because referrals would have come to the institution whether or not telehealth services were available. Others, especially in academic medical centers with remote clinics, may see a direct financial benefit by keeping their providers in their clinics seeing patients as opposed to spending the time traveling to required meetings or education programs. *Helpful Hint: While talking with or visiting an experienced site ask them how they approached the sustainability issue.*

- Project the positive outcomes (i.e., increased referrals, additional physician income, value added to the institution's mix of services, research opportunities, etc.), but do not ignore the potential pitfalls that may have been uncovered during the audio conferences or site visits with experienced telehealth programs. Barriers to telehealth still remain and it is important to address them as they relate to the plan for the new network. These barriers typically relate to provider acceptance and other interrelated barriers such as reimbursement, telecommunication costs, the Health Information Portability and Accountability Act (HIPAA), provider credentialing of providers, cross state licensure, liability, and others. *Helpful Hint: Do not let these barriers derail the proposed project. Experienced telehealth sites have dealt with all of these issues in one manner or another. Learn from their experience.*
- Perform a cost benefit analysis to determine how telehealth will contribute to the stability of the organization. *Helpful Hint: To do this one should involve the business development or accounting staff within the institution. If the institution is an institution of higher learning then involving the staff of the business school or graduate school students in the process may prove beneficial.*
- Develop goals and objectives that are attainable within a defined timeframe and have a reasonable chance of achieving the expected results. Ensure that strategies are developed to measure the goals and objectives. (*This is the initial strategic plan and the beginning of the evaluation effort.*) *Helpful Hint: During the conversations or site visits with the experienced programs, ask to review or get a copy of their plan.*
- Promote the concept to physicians, nurses, other clinical providers and administration. *Helpful Hint: Involve all clinical providers up-front in the development of the program and **identify a clinical champion or multiple champions** for the planned network! Selling the program to clinicians at this point will not be easy, unless one of the clinicians has first hand experience with telehealth or was present during the site visits to the experience telehealth sites. It is also easier on occasion for the clinical champion(s) to promote telehealth to another clinician.*

- Identify an administrative champion near the top of the organization that will help foster the right environment during planning and creation of the program. If at all possible, have the telehealth program written into the institution's strategic plan. This would demonstrate overall commitment to telehealth from the top, including Board level approval for the program.
- Consult with the institution's telecommunications and information technology (IT) staff. This should also include the IT security staff. Their buy-in and acceptance will be critical to the development of the planned network. *Helpful Hint: Let the telecommunication and IT staffs know that you will need their knowledge base and assistance in order to make the network a success. Give them the opportunity to help design the network and test equipment. In this process a cohesive and productive partnership will be formed between the telehealth, IT and telecommunications teams. Not to mention their assistance and expertise may save a lot of time and money as the network develops.*
- Lay the ground work with third party payers (if necessary) for the purposes of reimbursement for services delivered via telehealth. It is easier to educate third-party payers before beginning the program to assure that they understand what telehealth is and how it will be used. Even if legislation is in place that requires them to pay, they can be resistant if they don't understand telehealth. This can be detrimental to a telehealth program, especially in early stages of implementation. *Helpful Hint: Try not to reinvent the wheel here. In your conversations and research, various methods of approaching commercial payers and state Medicaid programs should have been uncovered. As such, choose an approach method that has been successful for one or more experienced telehealth networks. Medicare is already required by law to pay for many services.*
- Identify potential funding sources (if necessary) for starting your program. This would include looking for federal or state grants that fund telehealth programs. It would also include searching for funding through various foundations that fund



innovative projects. Obtaining funding through these mechanisms will be most welcomed by the institution's leadership. *Helpful Hints: (1) It may be easier to secure grants if one has already developed small telehealth pilot programs within the organization; and (2) While obtaining outside funding for telehealth is a good thing, one must understand quickly that the program will need to sustain itself in the event that outside funding is terminated or expires. Therefore, anyone starting a program must consider and address the sustainability issue from the start!*

- Identify potential telecommunication contracts that are already in place and that you can take advantage of in developing the network. It also includes identifying the applicable tariffs to your situation. *Helpful Hint: If you are a state based institution then contacting the State Chief Information Officer or Telecommunications Director may uncover contracts for discounted telecommunication rates that you may be able to use. If you are not part of a larger institution contact your state public utilities/service commission and have them look for applicable tariffs. There may be a telehealth or distance education tariff offered by one or more telecommunications companies that are applicable to the proposed network. Lastly, if talking to another telehealth network in the same state ask them how they are securing telecommunication services.*

## **II. Understanding the Telehealth Policy Landscape**

Familiarity with public policy issues related to the implementation and delivery of telehealth services is useful both from the perspective of the individual program and the telehealth field in general. Collaboration with other telehealth professionals provides multiple opportunities to effect change in the arena of regulatory and policy related issues impacting telehealth.

**Reimbursement:** The ability to bill and collect fees for providing clinical services via telehealth is a large issue for sustaining a telehealth program. The three areas one must concentrate on in this area are Medicare, Medicaid and commercial insurance companies.

- Medicare: To understand what telehealth services the Medicare program will reimburse one should go to the following web site and search for the Program Memorandums associated with telehealth or telemedicine. The Centers for Medicare and Medicaid Services (CMS) Program Memorandums will outline all of the specific information in regard to what Medicare will reimburse.
  - [www.cms.gov](http://www.cms.gov) (accessed 6/8/04)
- Medicaid: Telehealth reimbursement through the Medicaid program varies from state to state. As of June 2003, 20 state Medicaid programs reimburse telehealth facilitated health care services in some fashion<sup>1</sup>. It is recommended that anyone involved in telehealth check with their state Medicaid office to determine if they reimburse for telehealth and for what services. If one's State Medicaid program is not reimbursing for telehealth then it will be important to determine what other programs may have done to secure Medicaid reimbursement in their State. This information should be gathered while conversing with experienced telehealth programs. The two primary options for securing telehealth reimbursement from Medicaid programs that do not currently reimburse are:
  - (1) Negotiate with Medicaid, and explain how telehealth could reduce the time to diagnosis and treatment, reducing patient's acuity and reducing the cost of treatment. Telehealth may also reduce Medicaid's cost of transporting patients. Many states find this expense is in the tens of millions of dollars; and
  - (2) If negotiations fail, you may be forced to pursue a legislative mandate which is time consuming and may have negative political ramifications since Medicaid will feel that they are being "forced" to comply.

*Helpful Hint(s): (1) Make sure when talking with someone in the Medicaid office that they are familiar with telehealth before asking them if they already pay or*

*would consider paying for telehealth services; and (2) If one's state does not receive Medicaid reimbursement for telehealth, contact programs in other states that have secured such funding.*

- **Commercial Insurance Companies:** Like Medicaid, reimbursement through commercial insurers varies from state to state and region to region. It is recommended that one discuss this topic with experienced telehealth programs. There have been varying, but successful, approaches to obtaining commercial insurance payments for telehealth within certain states.

One useful publication on this topic is the Telemedicine Reimbursement Source Book. This publication provides a compilation of relevant laws, regulations and policies related to telemedicine reimbursement. It also covers recent legislative initiatives and relevant reports related to reimbursement. It is available through the Center for Telemedicine Law (<http://www.ctl.org/> - accessed 6/8/04). One may also look for reimbursement and licensure reports on OAT website (<http://telehealth.hrsa.gov/> - accessed 6/8/04).

**Privacy and Security:** Guidance on privacy and security issues is now governed by the Health Information Portability and Accountability Act (HIPAA). It is beyond the scope of this document to describe the HIPAA regulations that impact telehealth. However, before embarking upon a telehealth program one should meet with their local privacy and security officers as well as familiarize themselves with the HIPAA regulations, specifically the HIPAA Administrative Simplification provisions. These provisions outline the national standards for privacy and security regarding electronic health care transactions ([www.cms.gov/hipaa/](http://www.cms.gov/hipaa/) - accessed 6/8/04).

**Telecommunications:** Telecommunication policy is impacted at both the federal and state levels. On a federal level one needs to become very familiar with the Federal Communication Commission's (FCC) Universal Service Mechanism for Health Care. This mechanism is designed to provide equity between the cost of urban and rural telecommunication services as they are used in health care. The fund helps discount

rural telecommunications rate to a level equal to the closest urban area of a least 50,000 people.

The Universal Service Administrative Company (USAC), a non-federal entity, maintains overall responsibility for the Universal Service Fund administration for schools, libraries and health care institutions. The group that specifically manages the health care component of the fund is the Rural Health Care Division (RHCD) of USAC. USAC and the RHCD hold monthly audio conferences to discuss the program with experienced and non-experienced parties interested in obtaining telecommunication discounts for telehealth. **Please note this is NOT a grant program.**

This FCC program may save thousands of dollars for qualifying institutions wanting to develop telehealth networks. It is also important to realize that RHCD funds often arrive 6-12 months after the initial installation of the communication circuits. Telehealth programs must be prepared to pay the full price for their services until the rebate check from RHCD arrives. One should spend a significant amount of time on the USAC and RHCD web site learning how to take advantage of this important program (<http://www.rhc.universalservice.org/> - accessed on 6/8/04)

***Please note that any telecommunications budget for telehealth may be significantly impacted (lowered) by taking advantage of this program when applicable. Additionally, new changes to the program are expected in 2004.***

**Credentialing and Privileging of Providers:** The Joint Commission on the Accreditation of Healthcare Organizations (JCAHO) has issued standards for telehealth credentialing and privileging of providers. The applicable standard for any given situation depends upon whether the distant site is providing direct patient care or simply consulting with another provider.

The telehealth standards can be located within the medical staff standards on the JCAHO web site (<http://www.jcaho.org/> - accessed on 6/8/04). The user of this site may need to spend some time navigating the site because of its complexity.

It is strongly recommended that these standards be reviewed with the individual in charge of JCAHO compliance (if the facility is JCAHO accredited) before embarking upon a telehealth program. These standards should also be discussed with each originating site being considered as part of the network.

**Provider Licensing:** The delivery of telehealth services within a given state is generally not an issue. However, the delivery of services across state lines is a major issue. Since telehealth technologies eliminate distance, the ability to provide services across state lines has become much easier. There are arguments to make on both sides of this issue. First, as a consumer, one should be entitled to obtain the best healthcare services possible no matter where they exist. There are no laws preventing anyone from driving across state lines to obtain those services, it happens everyday. However, there are laws in many states that would prevent the same services from being delivered via advanced telecommunication technologies.

On the other hand, it can be argued that providing services across state lines electronically may compromise the jurisdiction of malpractice cases. In short, if a service is provided via telehealth is the provider assumed to be traveling to the patient or is the patient assumed to be traveling to the provider? This begs the question of jurisdiction when a malpractice issue is raised.

Regardless of one's stance on the issue anyone involved in starting or running a telehealth program needs to stay abreast of these issues. They can literally have an impact on a telehealth program overnight.

Organizations to contact regarding these issues include state Medical Boards, the Federation of State Medical Boards (<http://www.fsmb.org/> - accessed on 6/8/04) and the National Council of State Boards of Nursing (<http://www.ncsbn.org> – accessed on 6/8/04).

OAT contracted with the Center for Telemedicine Law in 2003 to prepare an update on state licensure laws, which is available at <http://telehealth.hrsa.gov/licensure.htm> (accessed on 6/21/04). OAT and CTL also sponsored an invitational workshop on state licensure in December 2003 to discuss strategies for overcoming barriers to cross state

electronic practice. A final report from that workshop, together with supplemental material, will be available from OAT in August 2004.

It is also very important to understand the limitations and scope of practice when contemplating the delivery of care via telehealth, especially across state lines.

**Malpractice and Liability:** One should address the liability issue, but not let it interfere with the development of the telehealth program. It is recommended that any provider inquire as to whether telehealth is covered under their existing malpractice coverage. In most cases there is a good likelihood that telehealth is covered and at no additional cost.

It could be argued that using an interactive telehealth link to see a patient in real time may in fact reduce liability by reducing the risk associated with recommending certain clinical tasks based on a regular phone call with another clinician. Everyday conversations between physicians occur over the phone where one physician is trying to describe a condition and hoping the other physician is interpreting that description appropriately. The ability to assess a patient's condition is much better via an interactive telehealth system than it is to rely on someone trying to interpret the condition based on a phone call. In short, if an interactive telehealth encounter alters the treatment plan for a patient and less risky procedures are implemented, then this is good for the patient and it also lessens the liability issue.

An argument could also be made that if telehealth is available and not used in a particular situation liability may increase. Using the best available tools in any health care situation helps ease the liability associated with treatment. Of course the most important thing is that it benefits the patient!

**Policy Summary:** The above issues represent a majority of policy issues facing today's telehealth programs. The take home point is that anyone involved in telehealth must stay abreast of all of these issues so that they can react when policy changes are proposed at the public or private level. One way to stay abreast of these changes is to join professional organizations that keep their finger on the pulse of policy issues. The

three most notable telehealth organizations that provide this information to their membership are:

- The Center for Telemedicine Law
- The American Telemedicine Association
- The Association for Telemedicine Service Providers

### **III. Lessons Learned in the Development of Telehealth Programs**

#### General Lessons:

- Telehealth is not about technology, it is about people! Technology cannot compensate for poorly provisioned services. Since the early 1990's when recent telehealth grant programs were developed, the technology has become relatively simple. Personnel must be well trained, and prepared to help users (e.g., providers, patients, presenters, meeting participants, etc.) have a positive experience. This requires simplifying the process, and taking the technology out of the hands of the users until they have become comfortable with the technology.
- Identify a clinical champion for telehealth within the organization. Then champion the champion! Let anyone and everyone know who the champion is inside and outside of your organization. The extra credit will go a long way.
- Telehealth services should be integrated as much as possible into the every day way that care is provided. This may require teams of managers, programmers and other staff to work together in order to integrate telehealth into the existing scheduling, billing and the medical records delivery system for patient encounters.
- "Build it (telehealth network) and they will come" does not work. Telehealth requires building external relationships among providers, administrators and other clinical staff at the originating sites. Additionally, it also requires support

among the same groups of individuals within the network hub. This internal support must go to the very top of the "hub" organization.

- If you can't staff it then don't build it. A telehealth network requires skilled human resources to run successfully.
- The issue of telehealth reimbursement is not going to be completely resolved in a short time period. Find areas where telehealth makes financial sense. A few of those areas include surgical follow up where the follow up is part of the global surgical fee, contracts with other hospitals for services, correctional telehealth contracts, and contracts with state mental health facilities. Also, continue to work with private, State and Federal reimbursement agencies in search of reimbursement for the service.
- Physicians adapt well to telehealth technologies that help them do their job more efficiently. Physicians must have all the resources available for them to perform their duties, just as if they were in a traditional clinic. Charting, paperwork, diagnostic test results and all other patient information must be easily accessible. Since the clinician can not touch the patient, the presenter must possess all the skills necessary to perform any component of the examination requested by the distant provider and provide concise feedback that allows the provider to make their diagnosis. From the clinician's point of view, telehealth must be just as easy as providing in-person care.
- The introduction of telehealth technologies alone will not impact established and solid patient referral patterns. The technology is secondary to the service being provided by a specialist to the patient and the referring practitioner.
- Don't let the issues of liability and confidentiality inhibit the development of a telehealth network. These issues are important but they are equally important when dealing with care provided face-to-face. Confidentiality issues can be dealt with technically and liability issues should be discussed with one's attorneys.



- The further away the rural originating site is from specialty medical services the greater the need for telehealth services and the more likely the acceptance of them. However utilization is typically lower in many of these areas simply because of the low population density.
- DO NOT work on telehealth policy issues in a vacuum. Become active within one or more of the telehealth associations that have policy subcommittees. The more people working on the same issue with a common voice the greater the impact on public or private policy issues.

#### Telecommunication Lessons:

- Always purchase your long distance service from "end to end" or "point to point". Purchasing baseline service (individual segments that form one circuit) from individual carriers for a long distance connection is a mistake. For example if one buys three T1 segments from different phone companies to form a complete circuit, then they will not know who to call if the line has trouble. The reason they will not know who to call is because the problem may be with any one of the three phone companies involved. If that three segment T1 circuit was ordered through one phone company, that company is responsible for the entire circuit and it is their job to work with the other two phone companies to trouble shoot the complete circuit.
- Always order telecommunication services (T1, ISDN) a minimum of 60 days in advance. This will give the telehealth network and the telecommunications company time to work together to get a particular link operating smoothly.
- Ordering ISDN PRI service doesn't necessarily mean that one has access to everyone else with the same service. There are many different calling plans with this service and depending upon the plan there may or may not be issues with connecting with other sites. Research all the options with this service so that the telecommunications companies know exactly what the service is to provide.

Also, make the telecommunication companies put their promises in writing so that there is solid documentation if problems arise.

- Set up a method for testing and certifying those who will dial into an ISDN PRI or IP based network. Do not assume because another site has ISDN PRI or IP connections that they will be able to call and connect on the first try. Without prior testing and certification there is a substantial risk of having a meeting, clinic, or educational program fail. The results of such failures can result in poor public relations material.
- Bid long distance services when possible in an effort to obtain the least expensive rate for a given service.

#### Equipment/Technology Lessons:

- Roll-about videoconferencing/telehealth systems are not easy to move. The newer models built on stainless steel carts or IV poles are easier to move than the older "room" systems. However, each room where videoconferencing will still require the digital ports necessary to make a connection to another site. Additionally, roll-about system may be more prone to failure as wires, components, and connections can loosen or disconnect as the unit is moved.
- Consider building/customizing a system based on defined needs and capabilities. Standards based equipment (components) can be purchased and mixed and matched. In many cases customizing a system using the component approach is less expensive than buying a turn-key telehealth system.
- Stay in contact with the equipment vendors to make sure that as new products are developed that important features are not removed and that there is downward compatibility between the new and the old devices.
- Avoid "proprietary" equipment and software! Proprietary equipment includes those devices and software that will not interoperate with others.

- It is very important to define clear requirements and specifications and then compare vendors on the findings.
- Ask for test equipment before purchasing so that it can be evaluated. If it is a medical device, the clinicians must be allowed to test it and make the selection.
- Whenever possible request equipment bids from multiple vendors in order to select the vendor who provides the biggest bang for the buck. Such bids should also address support after the sale.

The information contained in this section of the document has outlined the common elements of building a successful telehealth program and provided lessons learned and helpful hints in the process. The remaining sections of the document will concentrate on elements that are specific to individual applications of telehealth and telemedicine services such as dermatology, mental health, cardiology, and other specialties.

#### References

1. Telemedicine Reimbursement Report, Center for Telemedicine Law, June 2003, P.24.

## Chapter Three

---

### Cardiology

**Author:** Nina Antoniotti, PhD, Marshfield Clinic

#### I. Introduction

The purpose of this technical assistance document is to provide an overview of important and critical issues in the development of a telecardiology program. This document covers interactive consultations as well as store-and-forward applications (asynchronous). The document contains scientific information, program experiences, and anecdotal notes that will be useful in developing the operational and evaluative phases of a telecardiology project. Providing care through telecardiology access requires more than cost-effective completion of a technology installation. It is vital that a telecardiology program recognizes and duplicates the human interactions that occur during in-person health care. In addition, program operations should fit seamlessly into the organizational structure and functions currently in place. Medical and administrative support and operational infrastructures necessary to meet the clinical applications must be in place for the program to successfully meet the needs of patients and providers. Relationship building is the foundation for all telehealth applications (Armstrong and Freuh, 2002; p. 184).

#### II. Background

Telecardiology is the electronic transmission of cardiac data from the patient site to a consulting site for the provision of health care services. Patient encounters and provider consultations are possible through the transmission of radiographs, ECG's, laboratory results, echocardiograms, coronary arteriograms and ultrasounds; interactive video consultations including patient exam, stethoscopy, and medical history; and the use of store-and-forward information for second or confirmatory consultations.

Telecardiology is also a component of home health services when patient cardiac data

is monitored, stored, and transmitted to health care professionals who analyze, interpret, and make clinical decisions based on the data received. An example would be cholesterol or ECG monitoring. Telecardiology visits can be patient to provider, patient-to-patient, provider to provider, organization to organization, or any combination of the aforementioned. Telecardiology also includes patient accessed web-portals designed specifically for patients to access their records, make appointments, and receive information directly from their cardiologist or primary care provider.

Telecardiology is a rapidly growing segment of services that can be provided via telehealth technologies. Using diagnostic tools in the early phases of patient evaluation can result in the rapid triage, diagnosis, and intervention in acute and emergent cardiovascular conditions, particularly those that affect children. The use of real-time and store-and-forward echocardiography has revolutionized the local treatment of pediatric and adult cardiovascular patients and has led to more timely diagnosis and intervention (McConnell et al. 1999; Molinari et al. 2002 ; Scalvini and Zanelli, 2002; Shanit et al. 1996).

### **III. Step by Step Guide to Creating a Successful Program**

#### **A. Creating a Telecardiology Program within an Institution**

Assessing the need and demand for a telecardiology application requires general planning and development approaches that are applicable to the development of a telecardiology service. Reasons for the use of telecardiology for consulting providers includes the need to develop outreach services where on-site outreach is not practical or feasible; the need to continue an outreach service where cost expenditures are greater than revenue plus added value of maintaining the current service; the need to use in-person time for new patient workups not easily done via telecardiology (and thus, seeing follow-up patients via telecardiology); or to increase productivity by decreasing travel time. An originating site (patient site) may want to use telecardiology to:

- 1) provide access for their local populations;
- 2) bring specialty services to the local area in a collaborative fashion;
- 3) decrease out migration of patients based on perception of available services and the quality of those services;
- 4) decrease unnecessary transports to tertiary care facilities;
- 5) provide practitioner support; and
- 6) increase utilization of local ancillary services.

Telecardiology is best developed as a component of an integrated health care system, it cannot stand-alone. There must be a collaborative relationship either developed or in existence that is enhanced by the use of telecardiology. The originating site must maintain control of patient referrals, optimize on-site testing and other procedures offered locally, and believe that the service being provided belongs to the community in which they exist. The consulting (distant site) providers/organizations must allow the originating site this control over the process and not take the position that the consulting provider/organization controls the originating site's program. Coming to the table in discussions in a collaborative fashion when developing the program will create a higher level of buy-in from all parties concerned.

It is important for the new provider of telecardiology or the prospective recipient of telecardiology services to conduct a needs and demand assessment that identifies the local health care system assets, the disease specific needs of the population (incidence and prevalence of cardiovascular disease including cerebrovascular disease, peripheral vascular disease as well as the cardiac specific problems), the resources available throughout the region/system that could address those needs, and the likelihood that the local providers within the originating site area will refer patients to the Telecardiology program. Without this basic understanding of population-based health care needs, the primary goals of the program will be unclear. A telehealth initiative should be based on the local patient population's health care needs as well as services that may have a positive impact on longitudinal health status, health care cost, and quality outcomes. In addition, buy-in of local area referring providers may become a barrier if the local provider does not perceive a need for the service. The development of telecardiology

will then be seen as a threat to the practice of the local providers. Statistics on referral patterns can typically be obtained from the organization's Information Systems or Medical Records departments. State offices of Health and Human Services or the Center for Disease Control have statistics on incidence and prevalence of disease in specific geographic areas. Some State Medical Boards have listings of location and types of services provided by physicians and some non-physician providers. Asking the local community and the health care system where patients reside what they believe to be the most important services is an excellent place to start. Using data to support development of services is a non-threatening, easy approach to beginning discussions.

Before beginning, a provider/organization/network considering telecardiology should evaluate its readiness to embark on providing the service. An introspective look at the willingness to embrace telecardiology, the mindset to make telecardiology successful, and the vision to sustain telecardiology should be done in a multi-disciplinary environment that includes all the stakeholders. This process is no different for any other service provided via telehealth technologies. Top management, consulting providers, technical support staff, marketing, billing and coding as well as patient advocate staff should be included in the initial discussions and on-going evaluation. This organizational cultural assessment helps to uncover barriers to success and underscores the need to work together to develop a smooth and efficient telecardiology operation. An existing or potential telecardiology program (consulting as well as originating sites) should ask itself the following questions:

- 1) Is telecardiology considered "the way we do business?"
- 2) Since medical care is our greatest asset, do we use telecardiology to link people to that asset?
- 3) Have we identified a physician champion in each specialty department?
- 4) How do we support that champion?
- 5) Is telecardiology introduced as a way to enhance existing relationships?
- 6) Do we allow the specialist to 'own' the specialty?
- 7) Does telecardiology support the needs of the rural/remote population/patient/provider?

- 8) After telecardiology is implemented, is our relationship with that community better or worse?
- 9) Do we provide quality clinical experiences in that they are as close to in-person care as possible?
- 10) Have we measured patient satisfaction and if so, what do the results indicate?
- 11) Have we measured provider satisfaction and if so, what do the results indicate?
- 12) Do we link new services with identifiable needs within our own and partner organizations?
- 13) How do we document and report the benefits of the services we provide?
- 14) Do we involve key leadership in VIP visits to our program? (Adapted from an unpublished presentation by Tom Nesbitt, MD, OAT Grantee Meeting, 2000, Bethesda, MD).

Spending time answering the questions listed above will help those interested in developing telecardiology to construct an asset map that will identify the potential for success and to determine where additional groundwork may be needed before the actual planning, development, and implementation of a clinical telecardiology service. A program interested in developing strategies for access to care using telecardiology will find that taking time to answer these questions honestly and with all stakeholders involved in the discussion will not only strengthen the overall program but will increase the likelihood of a sustainable, successfully integrated telecardiology approach to health care delivery.

## **B. Planning the Program to Meet the Needs of the Underserved**

There are several elements of working with originating sites to consider. First is the referral relationship that may exist between the consulting and originating sites. In traditional practice patterns, a provider would refer a patient for specialty health care to a system with which the provider is comfortable, the provider has a previous relationship, and/or that is acceptable to the patient. In some cases, third-party payers may provide incentives for patients to seek care via telehealth due to lower out-of-pocket expenses for enrollees or for access to lower cost providers.



Telecardiology relationships are similar. If a health care network exists between primary, secondary, and tertiary levels of care, it would seem logical to provide services from the tertiary care specialists back to the secondary and primary care sites. If affiliate relationships exist for shared resources such as outreach clinics and mobile diagnostic services, it would again be reasonable to establish access to specialty care via telecardiology within those affiliate relationships. These 'relationships' can also include the supervisory capacity of physicians over remote based non-physician primary care providers such as nurse practitioners. A primary care physician's office may easily have a telecardiology link to a remote based nurse practitioner whose practice is a part of the primary care physician's office, but is physically located in a need area that is distanced from that physician. Telecardiology strategies are most successful in being adopted by patients and referring providers alike if those strategies follow established referral relationships already in existence when telecardiology implementation is being considered. Very rarely would one find a situation where a primary care office refers no patients for specialty care (Armstrong and Freuh, 2002; p. 171). The remaining issues are addressed under Operational Issues.

### **C. Technologic Analysis**

Technologies used in telecardiology are similar to those used in any other specialty that relies on a clinical physical exam to diagnose and treat patients via telehealth.

Transmission technologies are adequate if delivered at 128, 256, or 384 Kbps. Full T-1 bandwidth (1.5 Mbps) interactive video is not required to conduct adequate cardiology consultations for either new patient or follow-up visits. In a cost analysis of telecardiology, a T1 line may not be feasible from a cost perspective unless shared by other services that produce higher utilization, revenue and/or expense reduction. Lower transmissions speeds degrade motion handling and a live exam may be more difficult. However, the use of digital capture and rebuild built into many of the current transmission technologies as well as cameras preclude lower frame rates as being a barrier to successful telecardiology. Equipment is specific to the service(s) provided. A

comprehensive analysis of equipment for a telecardiology service can be found at <http://telehealth.hrsa.gov/pubs/tech/techhome.htm>.

In a nutshell, telecardiology providers and recipients should determine technology needs in the areas outlined in the following table. The table represents a list of equipment that is necessary for a telecardiology application, the use and function of the equipment, the features necessary, and pros and cons associated with each device.

Item	Description/Characteristics	Features	Pertinent Purchase Issues
<b>Video System Room Camera</b>	The room camera associated with the video system come in several types but are usually a moderate grade of standard video conference cameras that meet the specifications outlined in the standards for <b>Motion Video Systems – Main Camera</b> . This camera is important in developing a sense of total patient condition, as the cardiology patient is a multi-systems clinical consult rather than a targeted exam.	1 Chip CCD Image Sensor Auto Focus and White Balance Pan/Tilt/Zoom capabilities Remote controlled	Standard equipment, durable, works well in most lighting situations, non-intrusive to the patient, easily problem solved for technical failure, can be used to communicate integrated patient conditions much better than hand held cameras, frees the operator to assist the patient  Cost, no local Serviceability
<b>Patient Exam Camera</b>	These cameras come in several different types with various options. While these cameras all provide video some will capture a still image and some will greatly magnify an area of the skin. The placement of the camera and need for magnification will be directed by the cardiologist supervising the case.	Micro and Macro Lens Attachments  Video output to match the video input of the CODEC.	Excellent image and handheld  Expensive, magnification on some models may be too extreme for this specialty and add unnecessary additional cost to the camera. Would consider alternatives before purchase of these cameras
<b>Document Camera Fixed Arm with Base</b>	These cameras typically have a base and camera head much like an overhead projector. They can be purchased with sidelights and base light (for transparencies). Some have a fixed focal length while others have a head that can be rotated for use as a second room camera. The patient presenter typically places the body part on the base and under the fixed camera, or rotates the camera head to display the image requested by the clinician.	Auto Focus Auto White Balance Positive/Negative Switch Side Lights Base Light	Excellent images of the upper torso with rotating camera head units. Ability to show ECGs is excellent with immediate diagnostic capabilities In many cases the fixed tabletop unit makes it difficult to display lower torso images. Expensive, should consider gooseneck or articulated arm model for this specialty

Item	Description/Characteristics	Features	Pertinent Purchase Issues
<b>Document Camera – Goose-neck or Articulated Arm</b>	These cameras typically have a base that can be used with a tripod and a flexible head that can be positioned and maintained in a stationary position. They may or may not have auto focus. Because they are more flexible in terms of their placement they can be positioned to cover any part of the body.	Auto/Manual Focus Auto White Balance	Excellent image, Relatively Inexpensive, Can cover all parts of the body, Excellent viewing of EGC for immediate diagnostic capabilities, Some do not have auto focus, Camera must remain stationary, Requires a higher degree of manual dexterity on the part of operator
<b>Camcorder</b>	Commercial or high-end consumer grade camcorders are sometimes used in place of a Patient Exam Camera. These cameras produce an excellent image, are easily zoomed, have auto focus and white balance, and can be handheld or tripod mounted. The clinician directs the presenter on where to focus, zoom or add light.	VHS-C/8mm size unit Auto Focus Auto White Balance Directional Light Zoom	Excellent picture, Handheld or tripod mount, Relatively Inexpensive, Easy to use, Higher degree of attention to patient confidentiality with stored images
<b>Digital Camera</b>	These are basic digital cameras that capture images directly to disk or are downloadable to a PC. They are used in the same manner as a traditional 35mm camera.	Must adhere to format standards (i.e., JPEG)  Min. Resolution 460x680	Handheld; Easy to Use; Quality Image; Affordable; Greater degree of attention to medicolegal aspects of store-and-forward electronic patient information required; and If correct lighting and/or angles are not captured the cardiologist may not be able to interpret and may require that the patient return.
<b>Video &amp; Still Image</b>	Combination of the camcorder and digital camera gives the user the best of the video and still image world. This camera is preferred to a camcorder or digital camera as it integrates all applications into a flexible system that is adaptable and integratable to both clinical and technological situations.	All features of the digital camera and camcorder should be maintained	Excellent Video & Still Images Affordable Easy to Use Flexible and Integratable into existing information systems networks for image transfer
<b>Stethoscopy</b>	Digital or analogue stethoscopes provide the consultant with audio from auscultated body cavities including the lungs, major arteries, and the heart. Some stethoscopes work in-band and some only work out-of-band. Be sure to know the intended configuration prior to purchase. The end-user should always try the technology prior to purchase.	End user should have volume and tone control.  Patient end must have the ability to hear what is being transmitted.	Moderate cost. In-band options are more flexible but rely on CODEC for transmission.  Out-of-band systems can be used even if CODEC transmission goes down.

If providing telecardiology consultations/encounters to patients, consider methodology, bandwidth, video input devices, video output devices, lighting, background/room color, audio input devices, audio output devices, stethoscopy requirements (in band or out-of-band), patient room configuration, consultant room configuration and methodology for transmitting information between the patient and the consultant. Since telecardiology is a service that most often is interview structured involving a moderate amount of gross physical inspection, with particular attention to auscultation of body structures including the heart, lungs, arteries and abdomen, these technical issues must be addressed. Inspection of extremities and specific locations on the body of abnormal findings indicating poor cardiac function are dependent on lighting and shadow creation and not necessarily high camera resolution. Any program considering telecardiology must demonstrate the proposed auscultation technology to the clinician who will be providing service to ensure the quality of range of tone and volume, as well as the ergonomics of the equipment, is acceptable to that clinician and others who may use the system.

If determining **video input devices**, consider that the standard integrated video cameras included with videoconference systems may be sufficient for much of the needs for physical exam. These are often high quality cameras that offer motorized pan/tilt/zoom capabilities and are very functional for full body images used while interviewing patients. These highly controllable cameras may sometimes be used for viewing integrated components of a physical exam such as chest expansion, full-length abdominal incisions, or both lower extremities. These cameras are typically reserved for fixed based video systems in telehealth applications and should be reserved for higher bandwidth systems.

A high quality camcorder for viewing a more targeted, detailed exam such as peripheral edema, jugular vein distention, etc. is optimum. These cameras are flexible and can be used to show areas of the patient when the patient cannot move well or for hard to reach areas such as the back or sacrum (edema assessment). Modern camcorders often have high capacity zoom lenses and work well in a variety of light conditions. Electronic image stabilization and digitally freezing images are useful for removing motion artifacts.

A document camera (flat bed stand supporting a camera on a fixed arm) is a high quality camera used to show gross scale images on extremities, but they are difficult to manipulate to show all areas of the body. The base often has a built-in lighted view box to permit transmission of x-rays and ECGs or other hardcopy patient data (particularly patient logs or any written documents generated by the patient). Most of these cameras have power zoom controls, are auto-focus with manual focus override and have manual iris controls that work well in a variety of conditions. This extra equipment is only necessary if radiographs are to be shown during the consult. Other text data may be viewed with a camcorder on a small 3 to 6 inch tripod.

## **ECHOCARDIOGRAPHY**

A specific operational issue with respect to the implementation of telecardiology services is whether or not echocardiography is a service to be provided within the scope of the telecardiology program. Echocardiography is a diagnostic test performed by a technician to study heart wall motion that results in ejection fraction, a determination of how well the heart is working. Tests are for adult and pediatric patients. Many sites have echocardiography machines already on site – others receive mobile echo services. Echocardiograms are usually scheduled, non-emergent, and non-urgent. Although echocardiography can be done and is very useful in crisis situations, most telehealth echos are done as routine diagnostic procedures. There are two types of echos that can be transmitted over the telehealth network: taped echos and digital echos (real-time). Most echos are considered “store-and-forward” sessions. Taped echos are echos recorded through a standard VCR onto tape. This method of recording echos results in a 6-8% image loss which is acceptable for diagnostic purposes. The tape is viewed in the following manner: it is either played at the originating site on a VCR through the network and viewed by the cardiologist, or recorded again on a second tape to be viewed at a later time. In some cases the original VCR tape is also sent to the cardiologist for viewing on a standard VCR and monitor. Digital echos are recorded through a digital capture device which is a component or part of the echocardiography unit. The digital echo is captured immediately with 100% image capture and is considered “real-time” for that reason. This image is then sent via

special modems over analogue phone lines or across a wide area network to a digital receiving station at the consultant site. The digital receiving station captures the image and stores it on an optical disc for viewing by the cardiologist at a later time. This system also allows the stored file to be retransmitted to any other receiving station with 100% image capture. The review stations are typically housed within the cardiologist's PC. Some echo machines can be hooked directly to the CODEC or other switch device at the originating site in order to transmit a "live" echo to the provider. This configuration can also be used to transmit a "taped" echo, thus eliminating the need for the VCR. An additional benefit of a live echo is confirming the correct and enhanced placement of the probe for an individual patient. The cardiologist may have suggestions for a better picture that can be discussed and directed in a live consultation.

Technology needs for transmitting echos prior to, during, or after a telecardiology consult include:

- 1) VCR – The VCR used for echos can be a commercially available VCR, but it should be of high quality with emphasis on picture and sound quality and not accessory features. A four head machine is a minimum requirement. SVHS VCRs are optimum and must be placed in both the originating and consulting sites if used.
- 2) Tape – High quality VCR tape must be used to ensure integrity of the tape as well as resolution and sound quality. Commercially available tapes of high quality are acceptable. Packaging and storage of tapes is critical to ensure safe transfer of data from a technology standpoint as well as patient privacy.
- 3) Digital networks – These systems provide the best in image and sound transfer and are flexible in use and application. However, they are expensive and add an increased need for technology stations, receivers and viewers not found in most programs. The current telemedicine trend across the nation is to use tape and play the tape in-band in the network or send the tape to the consulting provider.

Technology is a tool for modern health care delivery. Telehealth consultations include technology that is totally foreign to most patients. When first hearing about telehealth, patients and providers often comment “that sounds real impersonal”. “How can the doctor tell what is wrong with me when he is 100 miles away?” “I like to get to know my patients well—how can I do that over a TV?” All sorts of unique challenges arise in establishing personal, caring relationships in this situation. The technology must be configured in a manner that minimizes its presence in the room and maximizes the patient’s attention on the provider. Locating microphones in the ceiling or in non-conspicuous places minimizes the patient’s shyness around microphones. Telehealth equipment should also be located at a level similar to what a patient would experience if they were seen in-person. Locations above forty-two inches from the bottom of the monitor place the equipment too high. Placing the equipment too low also distracts the patient unless the patient and provider would both be sitting in an in-person consultation, such as Psychiatry. Using twenty-two inch monitors (or similar size) most closely resembles the size of the provider’s features (when framed properly) if the patient were being seen in-person. Configuring exam rooms as close as possible to what the patient would experience if being seen in person gives the patient a sense of familiarity and comfort. (Armstrong and Freuh, 2002; p.187).

## **STORE-AND-FORWARD**

Store-and-forward (SF) applications use the same technologies, exam peripherals, and clinical protocols, to acquire data regarding the patient. That information is stored in a specific format and sent to a consulting provider for a diagnosis, interpretation, confirmatory opinion, second opinion, or for any reason that the input of the consulting provider is requested. SF requests can be as simple as a question posed in an email or as complex as a multi-media file containing narrative history and physical exam data, digital pictures, xrays, streaming video clips, and other imaging data sent electronically to a consulting provider. The oldest and most common form of SF telecardiology is the interpretation of electrocardiograms (ECGs). In most cases, the ECG is obtained by a tech at a time when the cardiologist or internal medicine physician is not present. The data is transmitted via standard phone lines to a receiving station or is merely printed

out and sent hardcopy, for the specialist to interpret at a later time. Other applications include the storing of data from echos, ultrasounds, VQ scans, fluoroscopy, etc., which is either sent by hardcopy file, to be downloaded at a later time, or electronically sent to a reading station, which downloads and archives the data. Other means of forwarding patient data may include software packages that are emailed and received at a reading station. The software based applications typically allow for the attachment of data files that include digital pictures, radiographs, and ultrasounds. SF applications in telecardiology are an efficient and effective alternative to providing diagnostic and confirmatory consultations to patient sites that do not have, nor can afford, interactive systems for live consultations. The SF application is also well suited for emergency care arenas where consultations are not available locally but readily accessible through tertiary care on-call systems.

#### **D. Operational Issues**

Telecardiology begins with a vision of connecting people to people, connecting resources to needs, and connecting health care problems to health care solutions. The first step to accomplish true integration begins with *understanding the practice patterns of the consulting provider*. The objective is to find out what is different about the process of care when done via telecardiology versus in-person. One mistake commonly made is to develop services via telecardiology by developing telecardiology processes and then asking the provider to fit into those processes. A more appropriate question to ask is “How can telecardiology fit into the existing practice flow?” A simple way to do answer this question is to follow the provider and write down what he/she does. Interviewing the office manager, the provider themselves, and any other staff involved in the process of care will add valuable information to setting up a telecardiology system that fits into the practice flow of the provider. Some important questions to answer are:

- 1) How are referrals made to this provider? Phone? Fax? In-person? Email?
- 2) Where do those referrals come from?
- 3) Who accepts the referral?
- 4) What information is needed at the time of the referral?



- 5) How is an appointment made?
- 6) What information is needed at the time the appointment is made?
- 7) How is the appointment communicated to the patient?
- 8) Where does the patient go when they arrive for the in-person visit?
- 9) What information is available at the time the patient presents?
- 10) What happens to the patient prior to being placed in the room? Weight? Vital Signs?
- 11) What information is collected by staff prior to the provider seeing the patient?
- 12) What documentation tools are used?
- 13) What information is available to the provider prior to seeing the in-person patient?
- 14) What information is available during the consult?
- 15) What is done during the clinical exam?
- 16) What tools are available to the provider for that exam?
- 17) What documentation is done as a result of the provider's exam and consultation?
- 18) What information is given to the patient at the end of the consultation?
- 19) How is the follow-up appointment arranged?
- 20) How are prescriptions processed?
- 21) How is the consult communicated back to the referring provider?
- 22) Any other miscellaneous information?

Once this information is collected, a flow diagram can be established to visually identify the process of care for the majority of consults. The next step is to identify what would change, if anything, when the provider sees patients via telecardiology. Common differences are usually not in what or how information is collected, but how that information gets to the consulting provider's site.

The only other difference that may be identified is the need to use appointment types that signal the patient was seen via telecardiology access and the use of a modifier for billing purposes. These differences are specific to the organization's process for billing and coding and scheduling appointments for patients. Many organizations use a separate appointment type other than traditional office codes to alert staff that the

---

patient is not physically present and to identify the visit for insurance companies as being a telecardiology consultation. The use of a modifier is recommended to identify for insurance providers that the visit was conducted via telecardiology. Medicare requires the use of a modifier for all telehealth consultations (*Program Memorandum*, May 15, 2001, HCFA, HHS).

If a third party, such as a scheduling service or office, is involved in scheduling the telehealth system (telecommunications network) for clinical consults, specific procedures need to be in place to coordinate appointments with providers, clinic exam rooms, network connections, and with the patient.

After the in-person process of care has been outlined and the differences identified, for visits done via telecardiology, a flow chart of a telecardiology visit can be developed. All pre-visit steps, as well as post-visit steps, should be included in integrating telecardiology in the procedure. The chart will help outline the steps that occur at the provider's office prior to engaging in the actual consultation. The same type of process flow chart should be developed for the originating site. These tools can be used to identify process points that require special considerations for documentation, communication, or other consultation needs, and can also be used for training and reference tools for office staff. The process of care can be identified by interviewing staff at both ends of the visit as to how the process occurs when the patient is seen in-person, pinpointing any critical differences if the patient were seen via telecardiology and then outlining the process in narrative form.

The second step in outlining the practice patterns is to *recreate the clinical exam*. Reproducing all components of the clinical exam needed by the specialty provider is the most critical component of a telecardiology visit. Accurate diagnosis and interpretation of assessment findings is crucial to the health and well being of the patient as well as reducing liability of all consulting providers. The specialty provider's individual clinical exam should be studied and the process outlined similar to the visit process in general. Telecardiology requires interview, physical exam, and discussion with family members. The individual practice techniques *must* be duplicated to ensure that the provider is

getting the information he/she needs in order to make an accurate and complete diagnosis. All aspects of the physical exam can be recreated via telecardiology technologies with room set-up, patient positioning, lighting and camera techniques. The only assessment technique that cannot be duplicated without prohibitively expensive technology is palpation. The consulting provider can directly supervise palpation when done during a telecardiology consultation by a licensed and properly trained presenter who is with the patient at the remote site. Typically, palpation can be accomplished by a registered nurse trained by that specific specialist in his/her individual techniques.

*Training of presenters by the specialist* is the third component of process flow. Optimally, the presenters should spend time on-site with the consulting provider learning the specific assessment techniques for telecardiology. If this is not possible or practical, special instruction should be available at the originating site so that exam techniques can be reproduced for the consulting provider. When the presenter's awareness of the provider and patient needs is heightened during teleconsultations, the presenter can predict and anticipate what might be needed and prepare the patient accordingly, as well as react more efficiently during the consultation. This efficiency during consultations is a benefit to the consulting provider and results in higher adoption rates of use of telecardiology by the providers. The patients perceive that they are being cared for by a competent and confident practitioner (the presenter) and tend to focus less on technology. Additionally, many human factors in patient care are preserved with this training.

Although there are no legislated requirements for a presenter, providing a trained presenter on the patient end has many benefits. If a registered nurse (RN) is trained as the presenter, he/she provides a variety of roles during the clinical consultation. The RN acts as an extension of the provider's hands, similar to the concept when pre-hospital care paramedics were first introduced into practice. The RN carries out on-site 'touching' of the patient through the use of cameras, sound devices, written and X-ray/photographic data, and hands-on assessment techniques under the direct supervision of the provider. If resources do not allow for an RN, a licensed professional

is an excellent second choice. If paraprofessional resources are not available, presenters should be trained to effectively run equipment, act as patient advocates, and to understand the health care process of consultation specific to the services provided.

Patients should not carry the burden of knowing the technology nor should they even notice the technology. Thus, the presenter should coordinate and operate all technology during the consult. He/she is trained in the use of videoconferencing equipment, communication techniques over videoconferencing and technical/clinical problem solving during consultations. The focus of the patient should be on communicating with the consulting provider. The role of the presenter in this regard is to operate the technology in a smooth and efficient manner so that technology does not distract the patient. The presenter also monitors the ability of the patient and the provider to communicate well via the technology. Watching to make sure words are not dropped, video images are not disruptive and that the full intent of the communication is received by each party is a critical responsibility of the presenter.

Effective communication is key to good health care and the presenter facilitates communication by watching for cues that something needs to be repeated, explained differently, that the patient is getting tired during long consults and needs a short break, and that the provider is hearing the full intent of what the patient is saying. In addition, many times the presenter hears something in the pre-consult conversation that is important for the provider to know and can remind the patient during the consult to mention the issue. In essence, the presenter acts as a patient advocate during the telecardiology consultation.

#### **IV. Lessons Learned from the Field**

The lessons learned are not different for telecardiology than for any other service implemented through telehealth technologies. With the exception of not locating stethoscopy in-band (in case the network system goes down, this exam technique can continue, particularly if critical to the diagnosis), few of the lessons learned in

implementing telecardiology are technology based. Most of the lessons learned fall into the following categories:

- 1) Telehealth is not about technology – it is about the clinical care of patients.
- 2) The development of relationships is the most critical factor in the success of a telehealth initiative.
- 3) Maintaining the human factors present in in-person visits through telehealth access is vital to patient and provider satisfaction.
- 4) Telehealth business planning is about more than return-on-investment or covering expenses – it is about the moral and economic incentives that health care systems and providers have in reducing the barriers to access to care for remote based populations.
- 5) A well-trained presenter is key to the efficient, effective and accurate practice of the provider via telehealth technologies.
- 6) Operational planning must include an assessment of current practice patterns and identification of variables that must be amended for telehealth. The question is not “How can my practice fit into telehealth,” but rather the question is “What is it about telehealth that must be changed to fit this practice?”

To put it quite simply, telehealth is not about technology, it is about people. Once an organization wishing to embark on a telehealth initiative realizes this important point, the implementation becomes easier. Building and sustaining relationships is the heart of telehealth. Telecardiology must be built based on a match of unmet needs and resource availability. Once a need is identified in a rural or remote community, a resource needs to be obtained and matched to the unmet service need. Simply using telecardiology for the sake of saying one is doing so does not create a successful program. Focusing on bringing human resources together with the needs other people is an excellent use of telecardiology, because it bridges the gap between distance/time and the patient/provider. Following traditional referral patterns is key to success in this area. A thorough investigation of what relationships exist prior to the implementation of telecardiology and whether those relationships can be maintained and enhanced after the implementation of telecardiology leads to a higher rate of adoption by both referring

and consulting providers as well as a high utilization by patients. Forcing “non-community member” viewpoints on how this system of access should work, by members who are not of the community, leads to resistance and low utilization.

Adopting a philosophy that telehealth mirrors services provided in-person is key to success. Find out what it is about the use of telecardiology technology as a tool for care that needs to change in order to fit into the provider’s practice – not what does the provider have to change about their practice to use telehealth strategies. Spend time observing provider’s practices and outlining the organization of care in each specialty practice by individual providers. Analyze that organization of care with respect to providing the same care via telehealth technologies. Mapping out processes/systems and recreating them in a pilot clinic to directly observe how each part of the organization of care might be delivered via telehealth is a valuable exercise. This systematic delineation of steps includes information prior to the start of the visit, who collects that information, exam techniques necessary to make a diagnosis, information exchange during the visit, documentation principles, prescription dispensing, patient education materials needed, and any and all processes for discharge and follow-up. This observational study is imperative in order to make consultations via telehealth time neutral for the provider. The success of programs is driven by this customization of telehealth processes to specialty services. In addition, providers who review procedures prior to implementation and conduct pilot clinics with known patients should be offered help to work out any concerns prior to implementing real consultations. Individual attention to the development and operationalization of clinical services based on the organization of care leads to a higher success rate with providers using telecardiology as a part of their daily practice.

The same principles are applied to the originating site. Programs that spend considerable time studying and understanding the patient experience as they access and participate in health care encounters will be more successful. Patient flow processes including check-in, registration, waiting area locations, exam room setups, medical records flow, follow-up appointing and any process included in the care of the patient at the remote site is evaluated using observational studies. Processes are

---

mimicked as close as possible to in-person care for patients receiving care via telehealth. Patients have the sense that they are coming to their local clinic for care, will be seen in comfortable, traditional exam rooms, and will have their primary care providers close by. Programs should use special framing techniques, color, and lighting to create the in-person experience over telehealth technologies. Minimizing the presence of the technology and focusing on promoting patient comfort leads to high patient utilization rates.

The other lesson learned in this area is the use of a specially trained telehealth nurse clinician. It is extremely important to have a well-trained presenter on the patient end. Provider time neutrality depends on the ability of the presenter to predict what the consultant may need during a consult, the camera skill and expertise of the presenter, and the creation of “a caring” environment by the presenter for both the patient and the provider.

The final lesson learned is in the area of sustainability. The key to sustainability begins with relationships – recognizing the existing relationships between patients and providers, between providers and providers, and between communities and communities. Respecting and building upon these relationships helps to create a network that adds value to a community’s health system and prevents redundancy and duplication of services. Using telecardiology strategies as a part of an integrated service delivery network rather than a stand-alone system also supports sustainability. The use of telecardiology is not the use of technology; it is the use of tools for access. Access is the availability and accessibility of services to remote based populations.

Telecardiology helps to transcend the barriers of distance and time between people – people who need health care resources and people who can provide those resources (services). Maintaining the human factor in all that we do, both for patients and providers, and consistent support and contact with both referring and consulting providers is critical to sustainability. In addition, telehealth solutions must be easy to use and available right in the provider’s clinical work area. The tools of telehealth should be as indispensable as the telephone or PC to clinical practice.

## V. Useful References

Armstrong M and Freuh S. 2002. Telecommunication for nurses-providing successful distance education and telehealth, 2<sup>nd</sup> Ed. Springer, New York.

McConnell M E, Dennis Steed R. Tichenor J M. Hannon D W. Interactive telecardiology for the evaluation of heart murmurs in children. *Telemedicine Journal* 1999. Vol 5, No 2; p. 157-161.

Molinari G; Reboa G; Frascio M; Leoncini M; Rolandi A; Balzan C; Barsotti A The role of telecardiology in supporting the decision-making process of general practitioners during the management of patients with suspected cardiac events. *Journal of Telemedicine and Telecare*, 2002. Vol 8, No. 2; p. 97-101.

Molinari G; Reboa G; Frascio M; Leoncini M; Rolandi A; Balzan C; Barsotti A The role of telecardiology in supporting the decision-making process of general practitioners during the management of patients with suspected cardiac events. *Journal of Telemedicine and Telecare*, 2002. Vol 8, No. 2; p. 97-101.

Nesbitt T. 2000. unpublished presentation, Office for the Advancement of Grantee Meeting, 2000, Bethesda, MD

*Program Memorandum*, May 15, 2001, Health Care Financing Administration, Health and Human Service, Washington, D.C.

Scalvini S., Zanelli E. Telecardiology: A new support for general practitioners in the management of elderly patients. *Age and Ageing*, 2002, Vol. 31, No. 2; p. 153.

Shanit D; Cheng A; Greenbaum R A. Telecardiology: supporting the decision making process in general practice. *Journal of Telemedicine and TeleCare*, 2002. 1996. Vol 2, No 1; p. 7-13.

Burgiss S, Sprang R, Tracy J. 2001. Telehealth technical guidelines. [www.telehealth.hrsa.gov/pubs/tech/techhome.htm](http://www.telehealth.hrsa.gov/pubs/tech/techhome.htm), Washington, D.C.



**VI. Sample Clinical Protocols - (see attachment A)**

**VII. Sample Technical Protocols - (see attachment B)**

---

## **ATTACHMENT A: SAMPLE CLINICAL PROCEDURES**

---

### **Telehealth Operations- Conducting a Telehealth Cardiology Visit**

---

Effective: 10/01/01

Supersedes:

File No. :

Approved By:

#### **1.0 PURPOSE**

This guideline is a template for obtaining and setting up equipment for a telecardiology visit. The intent of this guideline is to provide direction to the visit to improve efficiencies for the patient, provider, and Telehealth Nurse Clinician.

#### **2.0 SCOPE**

This policy shall apply to all Marshfield Clinic physicians, staff, employees and students at all locations that participate in or support clinical consultations via telehealth technologies.

#### **3.0 RESPONSIBILITY**

The interpretation and administration of this policy shall be the responsibility of the Program Manager for Telehealth

#### **4.0 POLICY**

##### **4.1 Guidelines**

- 4.1.1 Telehealth consults are appropriate for patients who have difficulty traveling, taking time off of work, and for patients who have any other socio-economic barriers to traveling for care. Requests for a telehealth consult may originate from the referring or consulting provider or the patient or patient's guardian.
  
- 4.1.2 Examples for telecardiology referrals are patients with Ischemic Heart Disease (suspected), Arrhythmias, Pre-Catheterization Workup, and Congestive Heart Failure. Refer to "Telecardiology Pre-appointment Workup sheet (Attachment A). The Telecardiology Pre-appointment Workup sheet (attachment A) is based on the underlying causes of the patient's symptoms. Select the appropriate work up and complete it prior to the telecardiology consult. This work up should be ordered by the referring MD.

4.2 Providers: Charles McCauley, Cardiologist, and John Hayes, Electrophysiologist , at the Marshfield Clinic, Marshfield, WI.

#### 4.3 Scheduling

4.3.1 To schedule an appointment, contact the MA at the provider site and/or the Appointment Coordinator at the THNC site. Refer to "Telehealth Appointment Processes" Policy.

### 5.0 PROCEDURE

5.1 Preparing for a Telecardiology Visit-Refer to the policy, "Preparing for a Telehealth Consult". Note that each site has a specific procedure book to aid in setting up at that location.

5.1.1 Obtain patient charts; prepare them as described in procedure "Preparing for a Telehealth Visit".

5.1.2 Connect the system for videoconferencing and prepare room following procedure "Preparation of Video Conference System and Camera".

5.1.3 Assemble supplies needed:

- Cloth gowns
- Blank prescription forms
- Cardiologist's business cards
- B/P cuffs--regular and large size
- Stethoscope (regular) for checking B/P
- Digital stethoscope and modem--See procedure "Connecting Digital Stethoscope for Use" and "Programming a Speed dial Number into a 3-com Modem".
- White drape sheets
- Disinfectant spray and paper towels
- Patient exam camera (video camera /digital still)
- Consents for cardiac catheterization
- Patient education booklet "Cardiac Catheterization/Coronary Arteriography"

5.1.4 Turn on digital stethoscope modem to connect to digital receiver in cardiology.

5.2 Conducting the telecardiology consult

5.2.1. Refer to procedure "Conducting a Telehealth Consult"

5.2.2 Patients that are new to Cardiology are sent a "Patient Questionnaire" (see attachment B) to be completed prior to appointment (see procedure

"Patient Communication Regarding Telehealth Appointments: Information and Reminder Letter"). This form will be FAXed to cardiology at the time of the visit.

- 5.2.3 Obtain patient weight, B/P on both arms for a new patient; one arm for a recheck with the patient sitting. Take a radial pulse (note any irregularities in rate or rhythm).
- New patients--write these vital signs on the first page of the "Patient Questionnaire"
  - Recheck patients--report vital signs to cardiology CMA over the videoconference system or by phone
- 5.2.4 Verify current medications and dosages, including OTC (over the counter). If patient has brought the medications in the original bottles, verify that they are taking as prescribed on the bottle.
- If patient is new to cardiology, these medications should be listed on the last page of the "Patient Questionnaire" that will be Faxed to the Cardiologist.
  - If this is a recheck cardiology appointment, the CMA from cardiology will review the medications with the patient over the videoconferencing system.
- 5.2.5 After this information is obtained:
- For new patients, FAX "Patient Questionnaire" to the appropriate Cardiology fax number.
  - For recheck patients, call Cardiology on the phone to let them know you are ready. Refer to Phone List for MA of MD you are working with.
- 5.2.6 Have patient change into cloth gown. For patient privacy, switch room camera to another camera on Extron while patient is changing. Place white drape sheet on chair for patient comfort and cleanliness. If you are sending a FAX for the consult, that is a good time to have the patient change. Slacks and clothing on the lower half of the body can be left on.
- 5.2.7 Assess pre-tibial edema. If edema is present, take digital still of edema to show to MD during consult.
- 5.2.8 New patients: Have patient sit on exam table for consult. If there is time before the consult begins, do abdominal assessment for enlarged liver, spleen, palpate femoral pulses and note any thrills or abdominal pulsation. If there is not time for this assessment before the consult, Cardiologist may request it during the consult, if needed. Also assess ankle pulses (posterior tibial) and pedal pulses (dorsalis pedis).
- 5.2.9 Recheck patients: Have patient sit in chair. Assess for edema of legs.

5.2.10 If another person is present with the patient, show both patient and person with patient. Information can be obtained from the interpersonal interaction; verbal and nonverbal.

5.2.11 The Cardiologist will direct the visit.

- First, the MD reviews the patient history and chart and asks the patient how they are doing.
- The MD will ask you to auscultate heart and lungs.
- Usual sites of heart auscultation are the aortic and mitral (see attachment C). The Cardiologist will direct you to listen to other areas if needed.
- For new patients, The Cardiologist may ask you to auscultate the heart sounds with the patient lying down as well as sitting.
- Other places the doctor may want auscultated are the carotid arteries and femoral arteries, for detection of bruits.
- Other observations that may be requested are palpating for thrills (see attachment D), abdominal pulsations, noting jugular vein distention and assessing central venous pressure (see attachment E).
- During auscultation, position yourself so that you are not between the room camera and the patient. This allows the MD to see where you have the stethoscope placed.

5.2.12 After the exam, the Cardiologist will speak with the patient again, regarding plan of care. If the patient needs to go to Marshfield for tests, the Cardiology CMA will make these arrangements on the videoconference system or call the patient at home.

- If patient is to have cardiac catheterization/ coronary arteriography, give patient the brochure on this procedure.
- Obtain consent for cardiac catheterization and HIV testing. Refer to procedure “ Obtaining Informed Consent”.
- If consent is obtained, send to cardiology CMA via clinic mail.

5.2.13 If labs are ordered to be done the day of visit, send patient to lab waiting area and have Cardiology order labs as cross facility lab work.

- If the labs are to be drawn on another date, write the lab tests ordered on the telehealth Appointment Form. Have the cardiology CMA order the lab work as cross-facility orders.

5.2.14 If a recheck is to be scheduled, write it on Telehealth Appointment Form and have patient take it to the appointment coordinators for scheduling.

5.2.15 Give patient the Cardiologist’s business card.

### 5.3 Documentation

5.3.1 If any prescriptions are ordered, the THNC writes them on a prescription form

or calls them to a pharmacy. Document medication orders in Document Manager following the procedure "Documenting Telehealth Patient Care in Document Manager.

#### 5.4 END OF VISIT

- 5.4.1 After the patient has left the room wipe down the room according to the "Infection Control Policy".

## ATTACHMENT B: SAMPLE TECHNICAL PROCEDURES

**TELEHEALTH OPERATIONAL GUIDELINES  
MARSHFIELD CLINIC TELEHEALTH NETWORK****I. Connecting Digital Stethoscope for Use**

- 1. The Send-modem is pre-programmed** to dial the destination (Receive) modem
- 2. Gather the following equipment:**
  - A. Headphones
  - B. Digital stethoscope
  - C. 56K Modem attached with computer cable to AMD Digital Sender
  - D. Two electrical transformers (power supplies)
- 3. Assemble as follows:**
  - A. Insert the chest piece, headphones, and the correct power supply into the digital send stethoscope (make sure the headphones and chest piece are in the correct outlet).
  - B. Plug the power supply (US Robotics) into the appropriate outlet on the back of the 56K modem.
  - C. Make sure all connections are tight and transformers are plugged into the wall outlet. The green light on the stethoscope should be lit. If it is not, make sure you have the right power supply plugged into the right piece of equipment.
  - D. Plug phone line into the appropriate phone outlet (far left back of modem or marked with an X).
- 4. Turn on the modem:**

You will hear the modem dialing the number (like a fax machine). When the connection is made you should have several red lights on. Be sure the "send" light is lit. You should be ready for the doctor to listen to the patient's heart or lungs.
- 5. Trouble Shooting:**
  - A. Be sure both transformers are plugged in and attached to the correct jack in the modem and Digital Sender. The green light on the stethoscope should be lit.
  - B. Be sure the chest piece and headphones are plugged into the appropriate jack on the Digital Sender.
  - C. Be sure the phone line is plugged into the correct phone port on the back of the Modem.
  - D. If the provider cannot hear, make sure the provider has his/her volume control turned up.
  - E. If the provider still cannot hear the heart/lung sounds, the modem may have dropped the call. Turn off the modem and unplug the power supply from the digital stethoscope. Plug the power supply back in the digital send-stethoscope. Turn on the modem and watch for the completion of the auto dial.

## Chapter Four

---

### **Dermatology**

**Authors:** Karen E. Edison, MD, University of Missouri Health Care  
Hon S. Pak, MD, Brooke Army Medical Center  
Joseph A. Tracy, MS, University of Missouri Health Care

#### **Contributing Editors:**

Nina Antoniotti, PhD, Marshfield Clinic  
Ann Bynum, EdD, University of Arkansas for Medical Sciences  
Susan Dimmick, PhD, University of Tennessee Graduate School of Medicine  
Elizabeth Krupinski, PhD, University of Arizona  
Norman Levine, MD, University of Arizona  
Ana Maria Lopez, MD, MPH, FACP, University of Arizona  
Cynthia Scheideman-Miller, MHA, Integris Health  
Ryan Spaulding, PhD, University of Kansas  
Rob Sprang, MBA, University of Kentucky

#### **I. Introduction**

Dermatology is a clinical specialty well suited for the use of telehealth technologies. It is one of the more common uses of both store and forward and interactive telehealth because of the visual nature of the practice. Dermatologists can provide high quality care to patients with diseases of their skin, hair, and nails using a variety of telehealth technologies. Education about cutaneous diseases and their management for patients and health care providers in underserved areas is also possible.

Teledermatology utilization has grown over the past several years. This is reflected in the 2003 survey of telehealth programs, which was conducted by the American Telemedicine Association's Special Interest Group on Teledermatology<sup>1</sup>. Results from this survey indicated:



- 36 states have telehealth programs that provide dermatology services;
- At least 62 programs in those states actively provide teledermatology services;
- Teledermatology using live interactive video is more common than programs using store and forward technologies (34 vs. 17);
- At least 7 programs use both live interactive video and store and forward (S&F) technologies to provide dermatology services;
- Live interactive encounters in 2002 ranged in number from 11 to 1040, with an average of 295 per program; and
- S&F encounters in 2002 ranged in number from 12 to 1500, with an average of 545 encounters per program.

This chapter will describe ways to implement and provide teledermatology services in three ways – via interactive video (ITV), store and forward (S&F) and a hybrid method using both ITV and S&F technologies. After reading Sections I – IV in this chapter, Section V provides examples of ideal ITV, S&F and Hybrid dermatology encounters/consults.

The reader should note that starting any telehealth project is a time consuming process. One should not expect to research, plan and implement a successful teledermatology program in a couple of months. Allowing a six-month window for researching and planning is a reasonable time period to devote to embarking upon a teledermatology program that has a good chance of being successful.

## II. Background

There is a shortage of dermatologists in many areas of our country and their geographic distribution is skewed toward metropolitan areas. In a 2002 report to the Board of Directors of the American Academy of Dermatology, Alexa Boer Kimball, MD and Jack Resneck, Jr., MD, reported that although the number of dermatologists per 100,000 population has grown from 1.6 in 1965 to 3.3 today, the demand for services has outpaced the supply of dermatologists<sup>2</sup>. In that report, Drs. Kimball and Resneck also suggest that telemedicine be used as a way to reach underserved populations. Some

feel that the issue is more of maldistribution and not an absolute shortage. This is compounded by an accelerated growth of laser and cosmetic dermatology, which has made fewer medical dermatologists available and worsened access to patients with routine skin problems. Logic suggests that although making dermatology services available via telemedicine means equal access to the service for those living in underserved areas, it will only increase the demand on the existing supply of dermatologists.

### **Real Time Teledermatology Via Interactive Videoconferencing**

In a real time teledermatology clinic a patient is seen via an interactive videoconference link to the dermatologist. In this type of encounter the patient may be accompanied by a medical assistant, a nurse, a nurse practitioner, a physician's assistant, a primary care physician, or in some instances by a telehealth site coordinator without medical experience or certification. This will depend on the location of the clinic, the on-site personnel available, and the agreement made with the originating site about who is required to be present with the patient during the encounter. While there are no regulations about who can present patients to a dermatologist via telehealth, it is recommended that the presenter have some minimal clinical background.

The quality of the interview and patient examination is highly dependent not only on the available equipment and physical attributes of the examination room, such as lighting and privacy, but is also dependent on the training of the originating site (remote) providers. In an originating site with few personnel, typically only one or two clinic workers will develop a high level of expertise in using the teleconferencing equipment and cameras. It is not uncommon, therefore, to have a situation where these particular workers are out of the office when teledermatology patients need to be seen. As such one should expect to work on occasion with an under-trained patient presenter.

The most significant benefits of real time teledermatology are:

- It is similar in nature to an "in-person" visit;

- It is reimbursable by Medicare, and in many states Medicaid and private payers also reimburse for this service; and
- Direct patient education can be delivered by the dermatologist.

### **Store and Forward Teledermatology**

Store and Forward (S&F) teledermatology is a method of virtually providing dermatology consultations in an asynchronous mode. In short, a patient's medical history (e.g. chief complaint, history of present illness, etc.) along with digital images are obtained and submitted electronically to the dermatologist by a trained individual at the originating site. In many cases this information is typically submitted as a packaged patient record. The images and other information are securely stored in a single personal computer (PC) or forwarded to a central server for easy retrieval. The dermatologist reviews the patient history and accompanying images and then submits a recommendation back to the originating site provider. Ultimately, the referring physicians at the originating sites typically manage the patients with the recommendations made by the dermatologist.

Although the process appears simplistic, it requires specific training because the encounter is not the same as the typical physician/patient in-person or ITV encounter. Although there are many similarities with real-time services, the photography training requirement is very different since the dermatologist is not there to guide the interview and examination. In the S&F model, the individual who facilitates the teledermatology consults is the key person who can make the program successful and much of the training revolves around this person. The use of standardized history forms, photographic protocols, and training are also key to the success of S&F teledermatology encounters.

Unlike encounters performed by interactive video, S&F teledermatology services are only reimbursed by Medicare when conducted within the federal telehealth demonstration projects in Alaska and Hawaii. S&F is also being reimbursed by MEDICAID in South Dakota and Minnesota. A limited but increasing number of third party payers are also reimbursing for this modality. Various groups continue to educate legislators on this issue with hopes of broadening reimbursement for S&F telehealth

applications in the future. For more information on reimbursement for telehealth the reader should refer back to Chapters One and Two.

As S&F techniques continue to improve and reimbursement becomes more widely available, the contributors to this document agree that the trend may be to move toward store and forward systems for dermatology. However, interactive encounters using videoconferencing technologies will continue to be used for dermatology as well.

The most significant benefits of S&F teledermatology are:

- The asynchronous format introduces clinical efficiencies for the dermatologist (e.g., more time efficient), therefore it is scalable to large volumes;
- It is more amenable for on line collaboration and second opinion given its asynchronous nature; and
- S&F teledermatology generally needs less technical assistance to accomplish the tasks necessary to support the service. While S&F generally has the originating site provider, the originating site nurse and the distant provider (specialist) involved in the process, an interactive environment generally has two other staff members involved, a nurse and technical person.

### **Hybrid Teledermatology (ITV and S&F)**

A combination of ITV and S&F technologies are now being used together to create a hybrid teledermatology service. The idea is to have patient information and images sent in advance of the real-time ITV teledermatology encounter. This provides the dermatologist with patient history information and high resolution images in advance of the real-time encounter making the real-time encounter with the patient more time efficient.

In this environment the staff at the originating site must be trained in the techniques associated with both ITV and S&F teledermatology. In short, they must know how to capture the correct patient information and images in advance, as well as understand how to use the video conferencing systems.

The most significant benefits of the hybrid model are:

- By receiving S&F patient information in advance the dermatologist can be more efficient with their time during the ITV encounter;
- Encounters are reimbursable by Medicare, and in many states Medicaid and private payers also reimburse for this service; and
- Direct patient care, including patient education, can be delivered by the dermatologist.

### **III. Step-by-Step Guide to Creating a Successful Program**

#### **A. Creating a Telehealth Program within Your Institution**

If the reader of this chapter is experienced in other areas of telehealth, their institution has probably accepted and adopted the telehealth concept. However, before going any further into this document, all non-experienced individuals interested in telehealth should take some time to read Chapters One (Introduction) and Two (First Steps in Creating a Successful Telemedicine Program) of this document. Those chapters provide very useful information regarding the creation a telehealth program within your own institution.

#### **B. Planning the Program to Meet the Needs of the Underserved**

Whether one is looking to create a real time or store and forward teledermatology program, it is important to understand the geographic areas and the demographics of the population intended to be served. In this process the reader should do the following:

- a) Assess the needs/demand for dermatology services in the underserved area via existing databases (e.g., State listing of specialists) and interviews with primary care providers. Obtain answers to the following questions:
  1. Are there dermatologists in the underserved area (within the same or neighboring county)?
  2. Where do patients in the underserved area currently go to receive dermatology services?

3. If dermatology services were available via telemedicine would they be of benefit to the provider?
  4. How often would the provider use the service?
- b) Assess the current referral relationship between the underserved area primary care physicians and the dermatologist(s), if any, operating in the area by obtaining answers to such questions as:

1. Is the current dermatology referral relationship and service positive, or is the relationship poor?

If the relationship is poor:

1. Is the originating site seeking alternatives because the dermatologist they have used in the past is booked beyond his/her capacity or isn't providing a valued service?
  2. Is the originating site looking for an alternative because the dermatologist they have used in the past has decided to accept only paying patients?
  3. Is the current relationship coming to an end as a result of retirement, relocation or for some other reason?
- c) Consider the existing relationships between the underserved area's providers (e.g., physicians, hospitals, health department, etc) and the short-term and long-term impact of implementing of telehealth in that area. In this process it is likely that potential partners will be identified (unless they sought the dermatology service on their own). However, in some cases one may also find that the providers in any given area do not want to work with their local dermatologist or their institution for a variety of reasons (e.g., poor service, lack of confidence in the provider).
- d) Assess the population of people necessary to support a dermatologist in the underserved area by contacting local health agencies, university based health

management programs or through health planning publications. The ability to recruit a dermatologist to an area insufficient in population to support such a provider will be difficult if not impossible. Thus teledermatology access may fill that gap.

- e) Consider holding a town meeting to discuss telehealth with the potential partners and originating site community. This may include individuals from the city/town council, business and industry leaders, school board members and of course members engaged in the delivery of health care services. Such a meeting gives the telehealth providers a chance to discover concerns, fears, support and desires on the part of the local community. The meeting should include:
1. A general overview of teledermatology and how it works to meet patient needs. In this first meeting the presenter should recommend that the community create an advisory group to assess and support the telehealth concept. It may also include discussions on how to make competing institutions partners in telehealth. The presenter should also address costs, benefits and barriers during this meeting.
  2. Consider hosting a separate “due diligence” meeting with many health care providers to assure them telehealth is being used in the community to provide dermatology services that do not exist and not as a tool to drain patients from the area. Provide as much information to the originating site providers as possible in order to give them some idea of what they can expect. The following items should be included:
    - a) The dermatologist should attend if at all possible. Health care providers prefer to know the specialists to whom they refer their patients. Have the dermatologist explain how he or she will communicate back with the referring providers regarding their patients. This may be via written documentation that is faxed, sent via secure email, or via the traditional dictated letter. Inform them that such a response will be clear and timely. Additionally, offer the originating site providers an easy communication

channel for asking questions of the dermatologists. If objections are raised regarding the communication methods, then ask the providers how they would like to receive feedback on the patients they will refer.

- b) Convey to the originating site providers that as news gets out into the originating site community about this service, patients will begin to refer themselves. Additionally, let the dermatologists at the distant site know that they need to decide if they will accept direct patient referrals, and if they do, how they will remotely manage patients with complicated conditions. Remember that accepting direct referrals without prior approval of some insurance companies could create a complicated reimbursement environment.
- c) Convey to the referring providers how the dermatologists would prefer to handle telemedicine cases. There are three ways this is typically done:
  - 1. The dermatologist can assume responsibility for the patient's initial and follow-up care;
  - 2. The dermatologist can partner with the patient's primary care provider and co-manage the patient; or
  - 3. The dermatologist may choose to provide only consultative recommendations to the primary care provider for the patient's management.

In short, the dermatologists will need to decide which method they would prefer to use or whether they will make the determination on a case-by-case basis. It should be noted that dermatologists using only store-and-forward technology will customarily be serving in a purely consultative role.

- d) Request that the originating site providers become part of a directory that will list everyone in the community capable of providing surgical and other procedural expertise (e.g., skin biopsy, simple excisions, cryosurgery, and



intralesional injections). This way the patient can remain local when such expertise is needed. This is another indication that telemedicine will help health care service remain in the underserved area. Please note that if this type of procedural expertise is not available, the patient may need to travel out of the local community for such services.

- e) Offer the referring providers the opportunity to spend time with the dermatologists in their clinics learning basic procedural techniques. In this way, full-service modern dermatology care may be provided in the underserved areas. Additionally, offer the staff of the referring providers (e.g., LPNs, RNs) an opportunity to also spend time with the dermatologists and their staff for the purpose of learning the procedural techniques and how the dermatologists utilize the skills of their staff during patient encounters.
3. Develop a telehealth agreement with the underserved site. This agreement should define the responsibilities of each party including staffing, costs, technical support, reporting, etc. In this process the reader should have gathered sample agreements from other telehealth programs as suggested in the Chapter Two. They should be used as the basis for the agreements that the reader will draft. **AN AGREEMENT MUST BE FINALIZED WITH EACH UNDERSERVED SITE BEFORE MOVING TO THE OPERATIONAL STAGE.** Otherwise, false expectations and misunderstandings may arise regarding which party is responsible for providing services, staffing and equipment for the teledermatology service.
  4. Offer to assist the community in their planning of the telehealth program in their area.

### **C. Technical Analysis**

Those embarking on a teledermatology program should begin their technical analysis by:

- a) Identifying teledermatology equipment used by other successful programs;
- b) Identifying transmission mechanisms used by other successful programs;
- c) Reviewing the federal Office for the Advancement of Telehealth's Technical Guidelines, especially as they relate to teledermatology (<http://telehealth.hrsa.gov/pubs/tech/derm.htm>) [accessed on 7/10/04];
- d) Exploring the Telehealth Deployment Research Testbed (TDRT) web site since it contains an evaluation of equipment used in interactive and store and forward teledermatology programs (<http://tdrt.aticorp.org/>) [accessed on 7/10/04]; and
- e) Reviewing the American Telemedicine Association's Teledermatology Special Interest Group web site - <http://www.americantelemed.org/ICOT/icot.htm> [accessed on 7/10/04]. This link has a wealth of information regarding both live interactive and store and forward teledermatology.

***After reviewing the information on the two web sites listed above and researching what other successful programs are doing, narrow the choices of equipment and allow the dermatologists to test and participate in the final selection of that equipment.***

Other Technical Considerations for ITV, S&F and Hybrid Teledermatology:

- a) Determine how on-going maintenance of equipment will be provided. This includes a decision to buy spare equipment or extended service contracts. The experience of the Missouri Telehealth Network staff suggests it may be less expensive to buy spare devices when the equipment has a warranty of 2 to 3 years. That way, the spare can be placed in the field while the broken equipment is repaired under its warranty period.
- b) Determine network connectivity options and associated costs. This means exploring all the types of telecommunication services that may be available in the underserved area (e.g., ISDN, xDSL, T1, IP). If considering store and forward, plain old telephone service (POTS) may be all that is needed.

- 
- c) Determine who will be responsible for network management from point-to-point – the distant site, originating site, the telecommunications company, or some third party.
  - d) Train the telehealth technical staff on proper room design. This includes understanding proper lighting (for videoconferencing and store and forward), sound and video placement for optimal telehealth presentations. For store and forward teledermatology it should also involve training the user on the techniques needed to take and transmit digital images of the patient. A couple considerations include:
    - 1. Lighting should be adequate enough to identify the primary lesions and their characteristics (see Chapter Fourteen for more information).
    - 2. A medium non-reflectant blue cloth or blue screen background should be used so that there is continuity in the images taken. The color should be similar to that used for blue screens in Hollywood.
  - e) Clothing and jewelry must be removed sufficiently to get adequate viewing.
  - f) Use chaperones as needed to assist with the patient.
  - g) Develop agreements to determine what happens when equipment is stolen or damaged.
  - h) Consider the development of protocols for equipment utilization and network connectivity. The protocols should
    - 1. Indicate how teledermatology connections between sites are to be scheduled and which site places the call; (e.g., set block of time each week, ad hoc, scheduled into an existing clinic, distant site makes the call); and
    - 2. Indicate how each piece of equipment works and how it interfaces with the video system or S&F system).

- i) Develop a frequently asked questions (FAQ) sheet that will help reduce the stress imposed by the Health Insurance Portability and Accountability Act. This should be done in conjunction with the distant site's privacy and security staff.
- j) Create an inventory tracking system for all equipment.

#### S&F Technical Considerations:

Below is a listing of technical considerations specific to S&F applications of teledermatology:

- a) Images should have a minimum resolution of 1024 x768 pixels with 24 bit color.
- b) All images must be properly focused.
- c) Camera exposure must be set properly to allow adequate evaluation given the light reflection. In some cases a flash may be necessary.
- d) For most conditions, standard protocols (see attachment D) should be used.
- e) Each image set should include standard views of an involved anatomic unit:
  - Scalp/Head (top, back, left, right)
  - Face (e.g. front, left, right)
  - Neck (front, back, left, right)
  - Trunk (front, back, flank if necessary)
  - Arms (both front, back)
  - Legs (both front, back, left/right if needed)
  - Groin/Buttock
  - Hands (both front, back)
  - Feet (both front, back)
- f) In general, the images should be taken perpendicular to the plane of the lesion/rash.

- g) Oblique views should be used if the lesion is subtle and difficult to evaluate its height.
- h) Complementary views should be included if the condition involves certain areas:
  - 1. Scalp- Face
  - 2. Elbows-Knees
  - 3. Antecubital Fossa-Popliteal Fossa
  - 4. Hands-Feet
- i) The image should be framed to show the areas involved and the areas not involved. (example: rash on hands in patient wearing long sleeve shirt, must expose the arm to show where the rash starts and stops).
- j) If possible, all images must be reviewed on the computer using an image viewer prior to the patient leaving to ensure the quality of the images. If this is not possible, re-takes may be necessary in some cases.

#### **D. Operational**

Steps 1, 2 and 3 in this section are likely to take 6 or more months before the operational stage is entered. The timelines below start only after steps A-C are completed. Please remember not to embark on an operational plan until a formal telehealth agreement is in place with the originating site.

##### **1. Start-up – The First 30 Days**

- a. If applicable, Universal Service Fund applications should be filed with the Rural Health Care Division (RHCD) of the Universal Service Administration Corporation (see Chapter Two). While this step can happen quickly do not order the telecommunications service until the 28-day waiting period required by the RHCD has expired, otherwise the service will not qualify for Universal Service funding.

- 
- b. Bids or comparison-shopping needs to be done to ensure best pricing of equipment and telecommunication services. Blind bidding can produce a large variation in pricing and save a great deal of money. Locating existing bids within the institution for video conferencing equipment, cameras, etc., may also save time in the purchasing process.
  - c. Conduct additional site visits for finalizing the technical placement of all equipment. The technical staff should:
    1. Identify the location of the telecommunications room/closet.
    2. Determine the room(s) to be used for telehealth encounters in conjunction with the administrative and clinical staff. They must ensure that wires can physically be run between the selected room(s) and the telecommunications closet.
    3. Determine the general layout of the room and what changes (lighting, sound, wall color), if any, need to be made. The telehealth agreement with the site should specify which party is responsible for any room modifications and wire pulls.
  - d. Hold administrative and clinical meetings to discuss the logistics of scheduling, billing, reimbursement, evaluation, consent, and other administrative issues related to the program.
  - e. Observe in detail how in-person clinics function and detail how telehealth will best fit into that environment. Provide the staff at the underserved site with information that details the ideal real-time or store and forward encounter.

## **2. The 31 to 60 Day Start-up Window**

- a. Continue working on all of the logistical issues related to scheduling, billing, etc.

- b. Order telecommunications services AFTER THE RHCD 28 DAY WINDOW CLOSES (if filing RHCD paperwork was applicable).
- c. Order all equipment.
- d. Order internal wire pulls for the originating site(s) (with termination jacks or plugs).
- e. Room remodeling, if needed, should begin around day 31. This includes any necessary cabinetry, wall mounts, painting, etc. to be completed by the 60<sup>th</sup> day.
- f. Develop or locate existing evaluation tools to pilot in the next step (see Attachment A of this Chapter). Each telehealth program will need to determine if the evaluation tools need to be academic (e.g., comparing dermatology diagnoses with telemedicine vs. traditional in-person care), financial (e.g., cost/benefit) or simply capture general utilization (e.g., patient origin, number of studies by diagnosis code, etc) data.

### **3. The 61 to 90 Day Start-up Window**

- a. Install equipment
- b. Configure and connect network devices.
- c. Test all equipment and network connections thoroughly for quality of service and security.
- d. Begin scheduling hands-on training sessions for the staff in the underserved community (physicians, nurses, other clinical staff and administrative staff). This includes training on hardware, software and perhaps traveling to the distant site (dermatologist site) to do some clinical and technical training with the dermatologist and his or her staff. See Attachment B for training consult managers using store and forward technologies.

- e. Finalize the logistics of scheduling, billing, medical recordkeeping medical record sharing, etc.
- f. Conduct mock cases to determine the smoothness of the process and to make refinements as necessary. This process should go from the referral process to the evaluation forms (if used) completed at the end of an encounter.

#### 4. The 91st Day – Time for Patient Care

- a. Begin caring for patients based on the groundwork laid during the first 90 days.
- b. Refinements and adjustments to the program can be made at this point.
- c. Begin collecting data per the evaluation plan developed earlier.

### IV. Lessons Learned from the Field

- **Dermatologists will experience a learning curve of an unknown time.** Confidence levels correlate with diagnostic accuracy. The dermatologists may want to see patients in person and via telehealth for an initial period of time until they become comfortable with their ability to render quality dermatological care.
- **Originating site health care providers will also experience a learning curve of an unknown time.** It takes time for the originating site health care providers, presenters and technicians to learn how to deliver teledermatology services. Each originating site will take varying amounts of time depending upon the amount of support and time given to the telehealth service.
- **Teledermatology is less difficult to implement if referral relationships with primary care providers in the community are already established.** However, this may not be the case, because communities with the greatest need for teledermatology typically lack easy access to dermatological services.



- **Teledermatology services will have a greater chance of success if the dermatologists are willing to drive to the community, meet with the medical staff, and perhaps give a dermatology lecture from time to time.** As in standard referral relationships, telehealth referral relationships are based on human connections and excellent service rendered over the long term.
- **Primary care providers need to know to whom they are referring their patients.** If in-person communications or visits are not possible, schedule a videoconference for the dermatologists to meet and greet the originating site physicians. Interactive educational programs via the network can also serve to introduce the dermatologists to the referring providers.
- **The dermatologist should discuss with the originating site medical staff what level of service they are prepared to render.** They may act as a consultant, as a co-manager, and sometimes as a direct caregiver for the patients. This of course depends on the clinical diagnosis and treatment plan. Additionally, ask the primary care providers to comment on what level of service they are expecting when they write a request for consultation via the teledermatology service.
- **Keeping the originating site health care workers adept at using the equipment is an ongoing challenge.** As with any telehealth service, teledermatology works best when clinics are frequently held. Even in the best of circumstances, personnel will come and go and take their expertise with them. Thus, be prepared for retraining users in all locations.
- **Use standard operating procedures and protocols for teledermatology encounters.** A standard protocol for patient presentation (ITV/Hybrid), for gathering a patient history (IVT/S&F/Hybrid), and for patient imaging (S&F/ITV/Hybrid) should be used.
- **Always take multiple images of the patient (S&F and Hybrid).**

- **Never take a picture at less than 6-12 inches (will vary with digital camera) from the patient (S&F and Hybrid).**
- **Consider turning off the flash when photographing the scalp, particularly in a patient with dark-colored hair (S&F and Hybrid).** The flash will wash out the image of the underlying scalp if it is used in this case.
- **If images need to be retaken at the request of the dermatologist ensure that the referring sites do not see this as an insult to their skills and abilities.** Use the retake session as a learning opportunity to improve on the process.

## V. Useful References

### **THE IDEAL REAL TIME LIVE-INTERACTIVE TELEDERMATOLOGY VISIT:**

*The dermatologist connects with the originating site and introduces him or herself. The originating site health care worker present with the patient introduces him or herself and asks the patient to do their own introduction. Ideally, this patient will be on the schedule and the dermatologist will know who referred the patient, why they were referred, and what level of consultative care is being requested.*

*First, the dermatologist should introduce everyone in the room by providing a wide angle video shot for the patient to see. This is not only required by current HIPAA regulations, it is necessary to inspire the confidence of the patient and to put the patient at ease.*

*Next, the dermatologist proceeds with taking a history of the current problem, much the same as if the patient were in person in the room. The history is completed while viewing the patient through the main videoconferencing camera. Judging the patient's general condition and demeanor, a key component of the clinical evaluation, can be accomplished using the main camera. Wide spread dermatoses can also be evaluated through the main camera before turning to the dermatology or close-up camera.*

*When both the history and overall exam are complete, the originating site health care worker is asked to switch to the dermatology camera. This can be accomplished by the dermatologist in an unusual situation, but it is best to let the originating site workers present with the patient learn to control the camera. While they focus the camera, they must be able to see what the dermatologist is seeing in order to obtain a clear, focused picture.*

*After the history and physical exam, the teledermatologist discusses his or her findings with the patient and explains the treatment plan. At this point, a determination will be made about who will be prescribing the medication and who will be providing follow-up care.*

*One advantage to live-interactive teledermatology care is the dermatologist's ability to ask for additional views and to take additional history depending on the condition of the patient. The dermatologist does not have to rely on the expertise of an originating site worker obtaining a history and taking photographs of skin. Another advantage is that this method of teledermatology provides the opportunity for patient education.*

### **THE IDEAL STORE AND FORWARD TELEDERMATOLOGY VISIT:**

*The originating site primary care provider has examined and taken a complete patient history and determined that a dermatology consult is necessary. At this point the primary care provider (PCP) should explain to the patient the procedure by which he or she will obtain a consultation with a dermatologist. This of course will involve explaining to the patient that digital pictures of their lesion, mole, rash, will be taken and sent securely to the dermatologist at a distant site.*

*Using a standard protocol, with the patient's consent, the PCP or their staff will capture still images of the patient and the affected area using a digital camera. These images will then be reviewed on the PC for quality purposes before they are sent securely to the dermatologist.*

*The primary care provider will explain that these images and the patient's history will be reviewed by the dermatologist who will later contact the PCP with an opinion on how to treat the condition.*

*Due to the asynchronous nature of the S&F consult, some patients may not return to see the PCP if the condition can be properly treated by oral or topical medications recommended by the dermatologist. The PCP may simply call in the prescriptions to the patient's pharmacy of choice.*

*The decision for follow-up care of the patient will be initiated by the PCP as necessary.*

### **THE IDEAL HYBRID TELEDERMATOLOGY VISIT:**

*The originating site primary care provider has examined and taken a complete patient history and determined that a dermatology consult is necessary. At this point the primary care provider (PCP) should explain to the patient the procedure by which he or she will obtain a consultation with a dermatologist and how the patient themselves will see the dermatologist without leaving their local area. This of course will involve explaining to the patient that digital pictures of their lesion, mole, rash, will be taken and sent securely to the dermatologist and informing them that their visit with the dermatologist will happen in real-time via videoconferencing technologies without requiring a drive to the dermatologist's location.*

*In a standard manner, with the patient's consent, the PCP or his/her staff will capture images of the patient and the affected area using a digital camera. These images will then be reviewed on the PC for quality purposes before they are securely transmitted to the dermatologist for review.*

*The PCP or his/her staff will explain to the patient that these images and the patient's history will be reviewed by the dermatologist prior to the patient's real-time ITV encounter with them. The PCP's staff will then arrange an appointment time for the ITV encounter with the dermatologist.*

*Prior to the ITV encounter the dermatologist should review the patient's history, chief complaint and the digital images. This will make the ITV encounter more efficient because the dermatologist will already know much about the case.*

*Upon the establishment of the ITV connection, the dermatologist will introduce him or herself to the patient and the patient presenter. The originating site health care worker present with the patient will then introduce him or herself and ask the patient to make their own introduction.*

*It is also very important at this point for the dermatologist to introduce everyone in the room by providing a wide angle video shot for the patient to see. This is not only required by current HIPAA regulations, it is necessary to inspire the confidence of the patient and to put the patient at ease.*

*Next, since the dermatologist has already reviewed the history and images, he or she has the option to gather additional information from the patient and/or take a real-time look at the patient's dermatology problem. Judging the patient's general condition and demeanor can be quite helpful in the clinical evaluation of the patient. However, the need to actually re-examine the affected area will be dependent upon the dermatologist interviewing the patient. In the ideal world the two patient exams involved in a hybrid teledermatology encounter would occur within the same week, if not in immediate proximity.*

*Using the history, digital images and real-time interaction with the patient, the dermatologist can then explain the diagnosis with the patient, what may have caused the problem, how the problem will be treated (e.g., Rx, surgery), what the patient can do to avoid the problem in the future (if anything) and whether or not a follow-up exam will be necessary.*

*Based on all of the information, the dermatologist may prescribe medications, order additional tests, request a biopsy, if necessary refer the patient to a local surgeon, or if a local surgeon is not available ask the patient to drive to the dermatologist's location for the surgical procedure.*

*The dermatologist also has the option of simply making recommendations in a consultative role to the PCP and let the PCP handle the patients care based on those recommendations.*

### **Teledermatology Books, Guides and Web Links:**

Teledermatology, Richard Wooton and Amanda Oakley, Royal Society of Medicine, January 2002, ISBN: 1-85315-507-1

Telemedicine and Teledermatology, G. Burg, June 2003, Karger Publishing, ISBN 3-8055-7463-0.

The Idiot's Guide to Teledermatology Imaging -

[http://www.healthcare.hqusareur.army.mil/telemedicine/TMED\\_pres/Guide/Guide.pdf](http://www.healthcare.hqusareur.army.mil/telemedicine/TMED_pres/Guide/Guide.pdf).

Telemedicine Information Exchange - <http://tie.telemed.org/> (search for Teledermatology)

Federal Office for the Advancement of Telehealth - <http://telehealth.hrsa.gov/>.

American Telemedicine Association's Teledermatology Special Interest Group -

<http://www.americantelemed.org/ICOT/icot.htm>.

Center for Telemedicine Law - <http://wwwctl.org/>

Association of Telemedicine Service Providers – [www.atsp.org](http://www.atsp.org).

### **VI. Sample Clinical Protocols – See Attachment C**

### **VII. Sample Technical Protocols – See Attachment D**

#### **References:**

1. 2003 U.S. Teledermatology Survey, Anne E. Burdick, M.D., M.P.H. and Shasa Hu, M.D. American Telemedicine Association – <http://www.atmeda.org/ICOT/sigtelederm.SIGSurveyDatabase2003-v.2.pdf> .
2. Report Looks At Dermatology Workforce Initiatives – Shortage of Dermatologists Addressed, Dermatology World, October 2002.

## Attachment A Sample Evaluation Form



### Patient Questionnaire

Thank you for being a telehealth patient! It is very important to us to learn all we can about telehealth. We need your help. Please take a minute to complete this questionnaire. Your answers will be kept confidential.

Date: \_\_\_\_\_ Time: \_\_\_\_\_

Patient Name: \_\_\_\_\_ Date of Birth: \_\_\_\_\_

- 1) How far did you have to travel to get here? \_\_\_\_\_ miles (one way)
  
- 2) How far would you have to travel to see the telehealth provider in person? \_\_\_\_\_ miles (**one way**)  
*[The telehealth provider is the out-of-town doctor or other health professional you saw on the TV.]*
  
- 3) How would you have handled your health problem without telehealth?
  - \_\_\_\_ Would not have received health care at this point. (Go To Question #6)
  - \_\_\_\_ Would have received health care in my own community. (Go To Question #6)
  - \_\_\_\_ Would have traveled out of town for health care.
  
- (4) What town would you have traveled to for your health care?  
 \_\_\_\_\_
  
- (5) How many miles is it from your home (**one way**)? \_\_\_\_\_ miles

6) Please circle the number that best shows your overall satisfaction with today's telehealth session.

1	2	3	4	5	6	7
<i>Very</i>		<i>Somewhat</i>		<i>Somewhat</i>		<i>Very</i>
<i>Dissatisfied</i>	<i>Dissatisfied</i>	<i>Dissatisfied</i>	<i>Neutral</i>	<i>Satisfied</i>	<i>Satisfied</i>	<i>Satisfied</i>

7) Please add any comments you have about telehealth or this project:

***Thank You Very Much for Your Responses!***

## **Attachment B**

### **Training Requirements for a Store and Forward Teledermatology Consult Manager**

Requirement: Approximately 8-16 hours of initial training

1. Receive hands on training on a digital camera (up to 2 hours)
2. Receive training on photographic techniques specific to teledermatology (see Attachment C & D) (up to 4 hours)
3. Learn the basic terms used in clinical dermatology as it relates to four major characteristics of skin disease. (up to 2 hours)
4. Learn to recognize the ten most common skin conditions (classic type only) to include seborrheic dermatitis, nevus, eczema, psoriasis, melanoma, basal cell carcinoma, and squamous cell carcinoma. (up to 2 hours)
5. Receive hands on training on the application to be used to enter consult data and upload images. (up to 2 hours)
6. Receive training on consult flow for his/her organization to include the patient enrollment procedures, follow up procedures, and exclusion criteria for teledermatology (up to 2 hours)
7. Receive training on how to prepare and set up room to take images of patients (use of background, lighting, etc) (up to 1 hour)

Receive annual refresher training on teledermatology photography. (2 hours)



## **Attachment C**

### **Sample Clinical Protocols**

#### **Store and Forward Teledermatology Protocol**

When obtaining images they should clearly the presence or absence of the following:

1. Distribution (Location of the involved areas) examples:
  - i. Single, Acral, Sun-exposed area, Diffuse, unilateral, segmental, etc.
  - ii. Distribution information is usually best portrayed using a Far-View image whether this is the whole body or just a body part such as a hand.  
Remember that this distant-view usually requires that the entire area involved including some uninvolved areas. In addition, unless it is a single lesion, including the contra lateral views of the body gives information on symmetry in this far-view. For example, if there is a lesion or rash on one knee, the frame should include both knees and the surrounding uninvolved areas of the leg.
2. Configuration (Arrangement of lesions with respect to one another) example:
  - i. Linear, Zosteriform, Annular, Nummular, Grouped, etc
  - ii. Configuration information is usually best portrayed using a medium-distance view as you are attempting to show any spatial relationship between the individual lesions if they exist. One should look for common configurations such as any linearity or annularity or other common configurations such as grouped lesions.
3. Primary Lesions and Secondary Lesions
  - i. Primary Lesion: (Represent the fundamental Lesion of the skin)
    1. Papule, Macule, Plaque, Patch, Vesicles, etc
  - ii. Secondary Changes: (Represent overlying skin changes)
    1. Scale, crust, keratosis, etc
  - iii. The primary lesion and secondary changes are best portrayed using a close up view in order to capture the most detail of the individual lesions along

- with any surface changes. This Macro or close up requires that a zoom lens is available or that the digital camera has to be physically close to the skin.
- iv. Standard images should be taken at 90 degrees from the lesion of interest.
  - v. It is optimal to place a small 10cm white/black tape ruler with mm markings next to the individual lesions to allow for approximation of size.
  - vi. The primary lesion(s) must be clearly identified, focused and centered in the close up view
  - vii. If there are multiple lesions are being evaluated, they must be marked using a unique nomenclature (a, b, c or 1, 2, 3 to allow easy identification and documentation). In addition, a close up of each different primary lesions must be captured.

4. For rashes or multiple lesions, additional views are need even if not involved:

<u>Involved</u>	<u>Include also:</u>
Hands	Feet
Feet	Hands
Elbows	Knees
Knees	Elbows
Antecubital fossa	Popliteal fossa
Fingernails/Toenails	All nails in hands and feet

- i. Show symmetry if rash or multiple lesions. Symmetry: If there is a rash on one side of the face, body or extremity, be sure to include the opposite side in the picture.
- ii. Show entire anatomic unit (e.g. trunk) if a lesion or rash is in that location.
- iii. Ensure that the location/anatomy is identifiable at least on one of the images.

5. For scalp problems, focus must be on the scalp not the individual hairs.

Always take the appropriate number of images based on the type of skin finding/complaint.

---

## Real-time Interactive Teledermatology Protocol

### Telehealth Dermatology Encounter – MU Health Care

**DATE:** April 6, 2001

#### APPROVALS:

\_\_\_\_\_ Karen Edison, MTN Medical Director

\_\_\_\_\_ Joseph A. Tracy, Executive Director of Telehealth

#### Appropriate Patient and Type of Consult

For those patients who, in the opinion of their physician, can receive follow up exams via the Telehealth system or have been referred by their primary care physician for a condition appropriate to be seen by a specialist through the use of the Telehealth system.

#### Referral and Scheduling Process

Patients call the Patient Access and Referral Services (*PARS*) at 573-882-7000 or 800-882-9000.

#### Telehealth Encounter Procedure

Physicians may schedule a physician consult by calling 573-877-7197.

### Pre-examination

#### Written documents

- Once an appointment is obtained, either the patient, the referring physician, or the originating site Telehealth coordinator will FAX to the hub provider site patient registration information, to include: name, address, phone numbers, SS#, DOB, current insurance, referring physician, prior diagnosis related to this consult, all current medications and doses and any other pertinent information needed for the chart.

- Originating site Telehealth coordinator will obtain the appropriate participation consent forms (Adult or Minor) immediately prior to the first Telehealth consultation per patient. Additional consent forms are not required for subsequent visits, but consultations cannot proceed without a signed consent on file. A copy of the consent form will be kept in patients chart, and the original sent within five working days to the MTN office at:

2401 Lemone Industrial Blvd.

DC345.00

Columbia, MO. 65212.

### **Room preparation**

- To connect the Telehealth system, MUHC initiates the call using the Polycom address book and the other site answers the call.
- Microphone(s) are highly sensitive and therefore the only consideration is placing the microphone(s) away from the monitor's speakers.
- Confirm that the Elmo and the Vizcam cameras at the patient site are working properly.

### **Patient preparation**

- Site coordinator at patient site will explain to patients participating in their first Telehealth consult how Telehealth consults take place, including that this system is confidential and only the health care professionals attending this consult and the patient can see and hear this session. Return patients should be reminded of this.

- Site coordinator or other health care professional at the patient site may take and record the patient's vital signs before the consult begins (weight, blood pressure, pulse and respiratory rate).
- Originating site coordinator or other health care professional responsible for the patient will bring the patient's chart to the Telehealth consultation in order to provide any needed information.
- Originating site coordinator or other health care professional responsible for the patient will stay with the patient during the Telehealth consultation to operate the Telehealth system, assist the patient as needed, to present any additional information the provider physician at the hub site may need and take any orders given by provider physician at hub site.

## **Examination**

### **Equipment**

In addition to the basic video conferencing system, a dermatology consult may include the use of the ELMO or the Canon Vizcam cameras to show patient characteristics and skin conditions. Cameras at both the physician and the patient sites should be set as per physician instructions.

### **Activities**

Interactive conversation with both patient and others (family, helper, etc.) present in the room at the patient site. Use the Elmo camera or Canon Vizcam camera to examine specific skin area(s).

## **Post-examination**

### **Patient instructions**

Provider physician will tell patient if and when they are to schedule a return visit, either via Telehealth or in person. The originating site coordinator or other health care

professional responsible for the patient will note this to chart and coordinate the return visit with the dermatology department.

**Evaluation forms**

The site coordinator may ask a sample of patients to complete the "patient questionnaire". Provider at hub site will be asked to complete "Office Staff" form. The site coordinator at the patient site will return all completed forms (fax or mail) within five working days to the MTN office at:

2401 Lemone Industrial Blvd.  
DC345.00,  
Columbia, MO 65212

## Attachment D

### Technical Protocols

#### Sample Technical Protocol for Store and Forward Imagery

##### Single Lesion (2-3 images)

- Take images of the involved anatomic units (e.g. trunk, face, etc)
- Medium View: (1 image) The lesion should be in the center of the frame. Include some anatomical landmark (e.g. belly button or joint) to ensure that the location is obvious.
- Close Up: (1-2 images) at the closest distance (usually 12" away from the lesion). Do not get much closer than 12" and consider getting an oblique view.

##### Localized rash or Lesion >1 (3-4 images):

- Take images of the involved anatomic units (e.g. trunk, face, etc)
- Distant View (1 image): Frame the rash or lesions so that the entire rash or lesions + ~25% of normal area are included within the image. Ensure that the location is specified by ensuring that an anatomical location is obvious.
- Medium (1 image): Look for configuration (linear, annular, circular lesions) If none, take a picture of a skin surface area of 2" x 2".
- Close Up (1-2 images): Look for a representative lesion and take a close up image at the maximum optical zoom at the closest allowed distance (usually 12"). Consider getting an oblique view.

---

### Generalized Rash (3-4 images)

- Take images of the involved anatomic units (e.g. trunk, face, etc)
- Distant View (2 images): Frame the rash or lesions so that the entire rash or lesions + 20% of normal area are included within the image. This will be either a total body (head to toe) image or truncal depending on the extent of involvement. If face/head and the distal arms and legs are not involved, take an image of the trunk and prox extremities in one frame- Front and Back. Head to Toe view in the proper anatomical position will be required – both front and back if face and trunk is involved.
- Medium (1 image): Look for configuration (linear, annular, circular lesions) If none, take a picture of an area of 1 square foot.
- Close Up (1 image): Look for a representative lesion and take a close up image at the maximum optical zoom at the closest allowed distance(usually 12”).



## Attachment D

### Sample Technical Protocol for Real-time Teledermatology

Missouri Telehealth Network

Advancing health care through telecommunications



## Canon Vizcam 1000

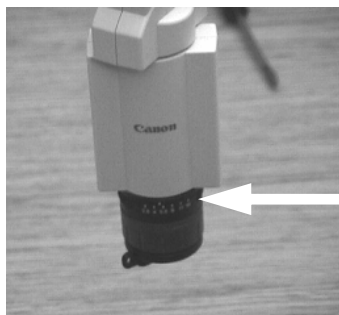

figure 1

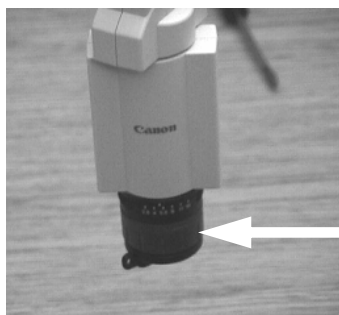

figure 2



figure 3



figure 4

1. Turn on the power switch for the Vizcam, located on the right side of the base. The tally lamp will light (*Note: The tally lamp is the small green light located at the front of the base of the Vizcam.*).
2. Select the Vizcam camera by using the Polycom remote control. Press the **NEAR** button followed immediately by the **2** button on the numeric keypad to select Camera 2.
3. Adjust lighting and focus. The black ring with numbers (*figure 1*) on it adjusts the aperture (available light), and the brown ring (*figure 2*) will adjust the focus. The recommended aperture setting is 2.8.

#### *Using the Vizcam 1000 for Dermatology:*

1. This camera must be moved into position and stabilized in order for the dermatologist to receive the best quality image. Stabilization is best accomplished using a tripod, table or cart. In no instance should this camera be handheld – it will produce an unacceptable level of motion artifacts for the dermatologist.
2. For very close work, it may be necessary to focus an additional light source on the subject. The Vizcam does not have an independent light source, and depends on the available light in the room.

#### Troubleshooting Suggestions

- Be sure the lens cover has been removed from the camera.
- Be sure the camera head is pointing at something besides a blank wall or tabletop.
- The DC IN power cable on the Vizcam must be plugged into a power outlet.
- SHUTTER SPEED selection switch on the base of the Vizcam should be set to 1/60 (*figure 3*).
- All LED indicators on the base of the Vizcam should default to the **OFF** (unlit) status (*figure 4*). Press selector switches once to toggle off if necessary.

Updated 04/12/02

# Disease Management

**Author:** Nina Antoniotti, PhD, Marshfield Clinic

## I. Introduction

The purpose of this technical assistance document is to provide an overview of important and critical issues in the development of a telehealth disease management program. This document contains scientific information, program experiences, and anecdotal notes that will be useful in developing the operational, and evaluative phases of a telehealth disease management project. Providing care through telehealth requires more than cost-effective completion of a technology installation. It is vital that the telehealth program recognizes and duplicates the human interactions that occur in in-person health care. In addition, program operations should fit seamlessly into the organizational structure and functions currently in place. Medical and administrative support and operational infrastructures necessary to meet the clinical applications must be in place for the program to successfully meet the needs of patients and providers. Relationship building is the foundation for all telehealth applications (Armstrong and Freuh, 2002; p. 184).

## II. Background

Telehealth, in a nutshell, includes the electronic transmission of patient data from the patient site (originating site) to a consulting site (distant site) for the provision of health care services. Consultations are possible through the transmission of radiographs, ECG's, laboratory results, echocardiograms, coronary arteriograms and ultrasounds; interactive video consultations including patient exam, stethoscopy, and medical history; and the use of store-and-forward information for second or confirmatory consultations. Telehealth is also a component of home health monitoring services when patient data related to blood pressure (BP), weight, pulse oxygen saturation, cardiac events, etc., is stored and transmitted to health care professionals who analyze, interpret, and make

---

clinical decisions based on the data received. An example would be cholesterol or ECG monitoring. Telehealth consultations can occur with patients to providers, patient-to-patient, providers to providers, organizations to organizations, or any combination of the aforementioned. Telehealth also includes patient accessed web-portals designed specifically for patients to access their records, make appointments, and receive information directly from their health care provider.

Disease management is a rapidly growing segment of services that can be provided via telehealth technologies. The level of interest in and knowledge about disease management is growing dramatically. The Institute of Medicine's report, entitled "Crossing the Quality Chasm," (2001) highlights the challenge of managing chronic conditions within a system that was designed to treat acute illness. Major national organizations such as the Disease Management Association of America (DMAA) have been formed to advance the practice of disease management, and the National Committee for Quality Assurance (NCQA) has established standards for disease management programs.

Early efforts at disease management occurred mainly in managed care settings, as the plan and the providers had clear incentives to manage care and the patients were enrolled and "locked into" a delivery system. More recently, a variety of health care organizations including physician group practices, private insurers, commercial firms, and academic medical centers, have developed programs designed to address the challenges inherent in managing chronic illnesses within the context of a fee-for-service (FFS) system oriented around episodic care.

The National Disease Management Association (NDMA), NCQA, and other organizations such as the National Pharmaceutical Council have put forward definitions of disease management that contain certain common elements. These definitions view disease management as an approach to delivering health care to persons with chronic illnesses that aim to improve patient outcomes while containing health care costs. These programs tend to target persons whose primary health problem is a specific disease, although certain co-morbid conditions are usually addressed as well. Patients

with a similar level of severity of a disease tend to face similar problems and therefore receive similar treatment plans. These disease management interventions tend to be highly structured and emphasize the use of standard protocols and clinical guidelines.

Certain common features are found in all of these definitions:

1. Identification of patients and matching the intervention with need;
2. Use of evidence-based practice guidelines;
3. Supporting adherence to the plan of care;
4. Supporting adherence to evidence-based medical practice guidelines by providing medical treatment guidelines to physicians and other providers, reporting on the patient's progress in compliance with protocols, and providing support services to assist the physician in monitoring the patient;
5. Services designed to enhance patient self-management and adherence to their treatment plan (e.g., patient education, monitoring/reminders, behavior modification programs aimed at encouraging lifestyle changes);
6. Routine reporting/feedback loop (may include communication with patient, physician, health plan and ancillary providers, and practice profiling);
7. Communication and collaboration among providers and between the patient and providers (e.g., team conferences, collaborative practice patterns, routine reporting/feedback loops, relaying information on co-morbid conditions, etc); and
8. Collection and analysis of process and outcomes measures.

In addition to these standard features, programs may include the use of information technology such as specialized software, data registries, automated decision support tools, and callback systems. Although disease management services usually do not include actual treatment of the patient's condition, many disease management programs augment the services provided in the traditional FFS system by adding services such as comprehensive patient assessment, social services, preventive services, and necessary

prescription drug and outpatient medication services. The interventions provided go beyond those services generally covered under the Medicare FFS program.

### **III. Step-by-Step Guide to Creating a Successful Program**

#### **A. Creating a Disease Management Program via Telehealth**

Needs assessments and general planning and development approaches are applicable to the development of a telehealth service. Reasons for the use of telehealth for consulting providers include the need to develop outreach services where on-site outreach is not practical or feasible; the need to continue an outreach service where cost expenditures are greater than revenue, plus added value of maintaining the current service; the need to use in-person time for new patient workups not easily done via telehealth (and thus, seeing follow-up patients via telehealth); or to increase productivity by decreasing travel time. An originating site (patient site) may want to use telehealth as a tool for access for their local populations; as a collaborative strategy to bring specialty services to the local area; to decrease out migration of patients based on perception of available services and the quality of those services; to decrease unnecessary transports to tertiary care facilities; for practitioner support; and to increase utilization of local ancillary services. Telehealth is best developed as a component of an integrated health care system. Telehealth cannot stand-alone. There must be a collaborative relationship either developed or in existence that is enhanced by the use of telehealth.

It is important for the new provider of telehealth or the prospective recipient of telehealth services to conduct a needs assessment that identifies the local health care system assets, the disease specific needs of the population (incidence and prevalence of chronic disease including cerebrovascular disease, peripheral vascular disease, diabetes, hypertension, etc. and the resources available throughout the region/system to address those needs. Without this basic understanding of population-based health care needs, the primary goals of the program will be unclear. In addition, buy-in of local

area referring providers may become a barrier if need is not perceived and the development of telehealth is seen as a threat.

Before beginning, a provider/organization/network considering telehealth should evaluate its readiness to embark on a telehealth service. An introspective look at the willingness to embrace telehealth, the mindset to make telehealth successful, and the vision to sustain telehealth should be done in a multi-disciplinary environment that includes all the stakeholders. This process is no different for any other service provided via telehealth technologies. Top management, consulting providers, technical support staff, marketing, billing and coding as well as patient advocate staff should be included in the initial discussions and on-going evaluation. This organizational cultural assessment helps to uncover barriers to success and underscores the need to work together to develop a smooth and efficient telehealth operation. An existing or potential telehealth program should ask itself the following questions:

1. Is telehealth considered “the way we do business?”
2. Since medical care is our greatest asset, do we use telehealth to link people to that asset?
3. Have we identified a physician champion in each specialty department that cares for populations with chronic conditions?
4. How do we support that champion?
5. Is telehealth introduced as a way to enhance existing relationships?
6. Do we allow the specialist to ‘own’ the specialty?
7. Does telehealth support the needs of the rural/remote population/patient?
8. After telehealth is implemented, is our relationship with that community better or worse?
9. Do we provide quality clinical experiences in that they are as close to in-person care as possible?
10. Have we measured patient satisfaction and if so, what do the results indicate?

11. Have we measured provider satisfaction and if so, what do the results indicate?
12. Do we link new services with identifiable needs within our own and partner organizations?
13. How do we document and report the benefits of the services provided?
14. Do we involve key leadership in VIP visits to our program? (Adapted from an unpublished presentation by Tom Nesbitt, MD, OAT Grantee Meeting, 2000, Bethesda, MD).

Spending time answering the questions listed above will help those interested in developing telehealth to construct an asset map that will identify the potential for success and to determine where additional groundwork may be needed before the actual planning, development, and implementation of a clinical telehealth service. A program interested in developing strategies for access to care using telehealth will find that taking time to answer these questions honestly and with all stakeholders involved in the discussion will not only strengthen the overall program but will increase the likelihood of a sustainable, successfully integrated telehealth approach to health care delivery.

## **B. Planning the Program to Meet the Needs of the Underserved**

There are several elements of working with remote sites to consider. First is the referral relationship that may exist between consulting and referring sites. In disease management initiatives, a call center or organized group of providers often manage a patient population for referring providers. In traditional practice patterns, a provider would refer a patient for specialty health care to a system with which the provider is comfortable, the provider has a previous relationship and/or that is acceptable to the patient. In a disease management initiative, the referring provider may feel that he/she is losing control of the patient. Telehealth relationships are similar. If a health care network exists between primary, secondary, and tertiary levels of care, it would seem logical to provide services from the tertiary care specialists back to the secondary and primary care sites. If affiliate relationships exist for shared resources such as outreach

clinics and mobile diagnostic services, it would again be reasonable to establish access to specialty care via telehealth within those affiliate relationships. These 'relationships' can also include the supervisory capacity of physicians over remote based non-physician primary care providers such as nurse practitioners. A primary care physician's office may easily have a telehealth link to a remote based nurse practitioner whose practice is a part of the primary care physician's office but is physically located in a need area that is distanced from that physician. Telehealth strategies are most successful in being adopted by patients and referring providers alike if those strategies follow established referral relationships already in existence when the telehealth implementation is being considered. Very rarely would one find a situation where a primary care office refers no patients for specialty care (Armstrong and Freuh, 2002; p. 171). The remaining issues are addressed under Operational Issues.

### **C. Technical Analysis**

Technologies used in telehealth disease management are similar to those used in any other specialty that relies on clinical physical exam to diagnose and treat patients delivered via telehealth. Transmission technologies are adequate if delivered at 128, 256, or 384 kbps. Full T-1 bandwidth interactive video is not required to provide disease management consultations. In fact, many consultations are provided via low-bandwidth technologies due to the lower cost and wide-spread availability. In an activity based cost analysis of telehealth, a T1 line may not be feasible from a cost perspective unless shared by other services that produce higher utilization/revenue per case/value added expense reduction. The degree of physical exam becomes more difficult at the lower transmission speed but with digital capture and rebuild built into many of the current transmission technologies as well as cameras, lower frame rates are not a barrier to telehealth. Equipment is specific to the services provided. The most comprehensive analysis of equipment needed for a telehealth service can be found at <http://telehealth.hrsa.gov/pubs/tech/techhome.htm>.



---

## Disease Management and Home Care

Home care is a relatively new application for telehealth. This specialty lends itself to various forms of camera and network technologies from interactive video conferencing to store-and-forward applications. Options for the way equipment may be purchased include packaged systems that include a clinician's station, patient unit, cameras and all peripheral equipment, or components which may be purchased separately.

In order to make an informed decision about whether to purchase a package system versus separate components, it is important to first consider what you want to do with the equipment and to investigate the capabilities of the equipment that is currently on the market. Some issues to consider about each component (whether purchased separately or in a package) include:

### Nurse's Station

1. This unit must be able to dial into the patient unit and vice versa;
2. Size and resolution of the interactive video picture should be considered (Patient/nurse comfort is important);
3. Consider how the medical record should be handled (via medical record software or the use of a paper chart); and
4. Consider whether the system should capture digital pictures.

### Patient Unit

1. Ability of the unit to be upgraded is very important;
2. Mobility of the equipment should be considered; and
3. Ability to attach medical peripheral devices (e.g, glucometer).

## Cameras

1. Auto focus and auto light compensation should be considered, as should remote tilt, pan and zoom;
2. Consider the benefits of a tripod (i.e., image stabilization);
3. Consider ease of moving the focus from one area of the body to another;
4. Length of the equipment cord(s) may be important;
5. Choose a zoom power and clarity that is appropriate to address the need;
6. Other components in the delivery of home care that should be considered:
  - 6.1 Blood pressure cuff
  - 6.2 Stethoscope
  - 6.3 Pulse oximeter
  - 6.4 Glucometer
  - 6.5 Thermometer
  - 6.6 Scale
  - 6.7 EKG leads
  - 6.8 Spirometer
  - 6.9 Peak flow meter
  - 6.10 Fetal monitor

The population to be served will determine which, if any, types of peripheral equipment are needed. Some peripherals are built into the patient unit, while others are add-on components. If considering the purchase of a patient unit that does not have built-in peripherals, it may be a good idea to look at hand held digital peripherals, because they

are less expensive. Keep in mind, however, that it can be difficult to hold hand held equipment steady and this may make it difficult to read the video screen. The handheld peripherals must also be held at a consistent distance from the screen if the patient unit does not have auto focus. Handheld peripherals may be placed on a table to provide a fixed and stable location for viewing by a remote nurse. Some peripheral components also require two phone lines to operate. If considering a two-line peripheral, the minimum length of the patient encounter needs to be calculated to justify the expense of installing an additional phone line. General tips for choosing equipment:

- Whether considering the purchase of a packaged unit or separate components, the number of visits to achieve a return on investment needs to be calculated.
- Evaluate different vendors, their methods, and utilize the reference list provided in this document.

If determining methodology, consider:

- POTS (plain old telephone service) interactive videoconferencing. Low bandwidth may cause somewhat jerky video and poor lip synchronization between speaker's lips and their voice; however, patient satisfaction with this methodology is extremely high. In home care, major benefits are accessibility and cost effectiveness.
- Store-and-forward still images. This technology requires that a presenter and a patient be together at the same time to capture still images. These images are then forwarded to the provider to be reviewed at a later time after the home visit. The provider is completely dependent upon the presenter's skill to determine what images need to be captured and the quality of those images. There is no real-time interactivity between the provider and the patient. These consultations can utilize fairly inexpensive technologies and low bandwidth connectivity (POTS, e-mail). The providers do not have to be present at the same time as the patient, and patient images can be batched together for review at a later time.

If determining video input devices, consider:

- Standard video cameras (as opposed to camcorders). These are often high quality cameras that offer motorized pan/tilt/zoom capabilities and are very functional for full body images while interviewing patients. These highly controllable peripheral cameras provide more magnification and greater resolution than most cameras that are integrated into patient units. These cameras can also be moved near the patient and can be placed on the floor, a table, on a tripod, etc., in order to get the most optimal view of the patient and problem area.
- High quality camcorder. These handheld camcorders are small and light and can be used to show images from the top of the head to the bottom of the feet. Modern camcorders often have high capacity zoom lenses and work well in a variety of light conditions. It is recommended that a camera stand (tripod) be used to hold the camera still to insure the best quality images. Electronic image stabilization and digital image capture are useful for removing motion artifacts.
- Camera attached to articulated arm. These cameras are often very similar to document cameras, but without the flat bed stand and lighted view box. The supporting arm is usually fairly flexible, allowing the camera to be used for a variety of purposes such as extreme close-ups of wound images, presenting documents or as a secondary room camera for general conferencing needs. These cameras often deliver very high quality images, but may lack the features of a document camera, such as auto-focus, and power zoom control.
- Compatibility of the audio and video inputs/outputs on the videoconference device or CODEC (coder/decoder) and the devices to be connected. The connectors on cameras, microphones, speakers or other peripheral devices must match the inputs on the CODEC to insure compatibility.

If determining video output devices, consider:

- It is possible to purchase a video conferencing device either separately or as a combination unit with a television monitor. If purchasing a video conferencing device and television monitor separately, note that a larger television screen will not increase the resolution of the image. In fact, the image will seem clearer on a

smaller screen. This is due to the resolution being generated by the video conferencing system as well as the size number of scanned image lines of the TV monitor. In many cases, the larger the TV screen, the farther apart the scanned lines are and this can make the image appear fuzzy. The smaller the screen, the closer the scanned lines and the clearer the image appears. Most systems work well with up to 13-inch video monitors.

Protocols for equipment utilization should be developed to ensure that providers conduct efficient patient encounters. Some protocols to consider: When considering telehealth disease management as an option for care for a particular patient, consider whether or not the patient will have to help complete the telehealth visit and whether or not assistance is needed and/or available to help with equipment. These factors may help with the selection of appropriate equipment. In any event, the easier and more human independent the equipment is to use, the more successful the telehealth disease management program will be.

Technology is a tool for modern health care delivery. Telehealth consultations include technology that is totally foreign to most patients. When first hearing about telehealth, patients and providers often comment “that sounds real impersonal”. “How can the doctor tell what is wrong with me when he is 100 miles away?” “I like to get to know my patients well—how can I do that over a TV?” All sorts of unique challenges arise in establishing personal, caring relationships in this situation. The technology must be configured in a manner that minimizes its presence in the room and maximizes the patient’s attention on the provider. Locating microphones in the ceiling or in non-conspicuous places minimizes the patient’s shyness around microphones. Telehealth equipment should also be located at a level similar to what a patient would experience if they were seen in-person. Locations above forty-two inches from the bottom of the monitor place the equipment too high. Placing the equipment too low also distracts the patient unless the patient and provider would both be sitting in an in-person consultation, such as a psychiatry encounter. Using twenty-two inch monitors (or similar size) most closely resembles the size of the provider’s features (when framed

properly) if the patient were being seen in-person. Configuring exam rooms as close as possible to what the patient would experience if being seen in person gives the patient a sense of familiarity and comfort. (Armstrong and Freuh, 2002; p.187).

The additional unique technologies used in many telehealth disease management initiatives are similar if not identical to those used for TeleHome Care as many telehealth disease management initiatives are structured to connect providers to patients in their homes. Public health staff, home health agencies, and clinic based clinicians involved in disease management strategies are connecting to patients in their homes, where health care is often needed, but not feasible or economically viable to deliver. Therefore, many of the technologies used for video transmission are POTS based, transmitting information at 21-33 Kbps.

**Physiological data monitoring equipment** including blood pressure/pulse/respiration devices, glucose monitors, weight scales, and devices used to measure bleeding times, are managed by the patient with the results being transmitted over a phone line or a wireless connection to a secure server that stores the data. In several systems, software analyzes the data for critical values and transmits alert messages to designated providers. Patient accessible web portals also offer an opportunity for patients to securely enter physiological data into their files that are then reviewed by clinicians. Email is used in many instances to communicate physiological data and changes in treatment plans back and forth between patients and providers.

#### **D. Operational Issues**

Telehealth begins with a vision of connecting people to people, connecting resources to needs, and connecting health care problems to health care solutions. The first step to accomplish true integration begins with *understanding the practice patterns of the provider*. The objective is to find out what is different about the process of care when done via telehealth versus in-person. One mistake commonly made is to develop services via telehealth by developing telehealth processes and then asking the provider to fit into those processes. A more appropriate question to ask is “How can telehealth fit

into the existing practice flow?" A simple way to answer this question is to follow the provider and write down what he/she does. Interviewing the office manager, the provider, and any other staff involved in the process of care will add valuable information to setting up a telehealth system that fits into the practice flow of the provider. Some important questions to answer are:

1. How are referrals made to this provider? Phone? Fax? In-person? Email?
2. Where do those referrals come from?
3. Who accepts the referral?
4. What information is needed at the time of the referral?
5. How is an appointment made?
6. What information is needed at the time the appointment is made?
7. How is the appointment communicated to the patient?
8. Where does the patient go when they arrive for the in-person visit?
9. What information is available at the time the patient presents?
10. What happens to the patient prior to being placed in the room? Weight? VS?
11. What information is collected by staff prior to the provider seeing the patient?
12. What documentation tools are used?
13. What information is available to the provider prior to seeing the in-person patient?
14. What information is available during the consult?
15. What is done during the clinical exam?
16. What tools are available to the provider for that exam?
17. What documentation is done as a result of the provider's exam and consultation?
18. What information is given to the patient at the end of the consultation?
19. How is the follow-up appointment arranged?

20. How are prescriptions processed?
21. How is the consult communicated back to the referring provider?
22. Any other miscellaneous information?

Once this information is collected, a flow chart can be established to visually identify the process of care for the majority of consults. The next step is to identify what would change, if anything, when the provider sees patients via telehealth. Common differences are usually not in what or how information is collected, but how that information gets to the consulting provider's site.

The only other difference that may be identified is the need to use appointment types that signal the patient was seen via telehealth and the use of a modifier for billing purposes. These differences are specific to the organization's process for billing, coding and scheduling appointments for patients. Many organizations use a separate appointment type other than traditional office codes to alert staff that the patient is not physically present and to identify the visit for insurance companies as being a telehealth consultation. The use of a modifier is recommended to again identify for insurance providers that the visit was conducted via telehealth. Medicare requires a modifier for all telehealth consultations (*Program Memorandum*, May 15, 2001, CMS/HCFA, HHS).

If a third party entity is involved in scheduling the telehealth system (telecommunications network) for clinical consults, specific procedures need to be in place to coordinate appointments with providers, consult rooms, network connections, and with the patient.

After the in-person process of care has been outlined and the differences identified (if the visit is done via telehealth), a flow chart of how a telehealth consultation occurs can be developed. All pre-consultation steps, as well as post-consultation steps, should be included in the procedure. The chart will help outline the steps that occur at the provider's office prior to engaging in the actual consultation. The same type of process flow chart is developed for the originating site. These tools can be used to identify process points that require special considerations for documentation, communication, or



other consultation needs, and can also be used for training and reference tools for office staff. The process of care can be identified by interviewing staff at both ends of the consult as to how the process occurs when the patient is seen in-person, pinpointing any critical differences between in-person and telehealth access, and then outlining the process in narrative form.

The second step in outlining the practice patterns is to *recreate the clinical exam*.

Reproducing all components of the clinical exam needed by the specialty provider is the most critical component of a telehealth consultation. Accurate diagnosis and interpretation of assessment findings is crucial to the health and well being of the patient as well as reducing liability on behalf of the provider. The specialty provider's individual clinical exam should be studied and process outlined similar to the consultation process in general. Telehealth requires interview, physical exam, and discussion with family members. The individual practice techniques *must* be duplicated to ensure that the provider is getting the information he/she needs in order to make an accurate and complete diagnosis. All aspects of the physical exam can be recreated via telehealth technologies with room set-up, patient positioning, lighting and camera techniques. The only assessment technique that cannot be duplicated without prohibitively expensive technology is palpation. The consulting provider can directly supervise palpation when done during the telehealth consultation by a licensed and properly trained presenter who is with the patient at the remote site. Typically, palpation can be accomplished by a registered nurse (RN) trained by that specific specialist in his/her individual techniques.

*Training of presenters by the specialist* is the third component of process flow. If possible, presenters should spend time on-site with the consulting provider learning the specific assessment techniques for telehealth. If this is not possible or practical, special instruction should be available at the originating site so that exam techniques can be reproduced for the consulting provider. When the presenter's awareness of the provider and the patient needs is heightened during teleconsultations, the presenter can predict and anticipate what might be needed and prepare the patient accordingly, as well as react more efficiently during the consultation. This efficiency during consultations is a

benefit to the consulting provider and results in higher adoption rates of use of telehealth by the providers. The patients perceive that they are being cared for by a competent and confident practitioner (the presenter) and tend to focus less on technology. Additionally, many human factors in patient care are preserved with this training.

Although there are no legislated requirements for a presenter, providing a trained presenter on the patient end has many benefits. If an RN is trained as the presenter, he/she provides a variety of roles during the clinical consultation. The RN acts as an extension of the provider's hands, similar to the concept when prehospital care paramedics were first introduced into practice. The RN carries out on-site 'touching' of the patient through the use of cameras, sound devices, written and X-ray/photographic data, and hands-on assessment techniques under the direct supervision of the provider. If resources do not allow for a registered nurse, a licensed professional is an excellent second choice. If paraprofessional resources are not available, presenters should be trained to effectively run equipment, act as patient advocates, and to understand the health care process of consultation specific to the services provided. In the home, a presenter may be an RN, LPN, other paraprofessional, a family member, friend or in some instances the patient.

Unless the patient is well trained and able to operate the equipment (e.g., home monitoring devices, video phones, etc.) they should not carry the burden of knowing the technology. Thus, the presenter should coordinate and operate all technology during the consult. He/she is trained in the use of videoconferencing equipment, communication techniques over videoconferencing and technical/clinical problem solving during consultations. The focus of the patient should be on communicating with the consulting provider. The role of the presenter in this regard is to operate the technology in a smooth and efficient manner so that technology does not distract the patient. The presenter also monitors the ability of the patient and the provider to communicate well via the technology. Watching to make sure words are not dropped, video images are not disruptive and that the full intent of the communication is received by each party is a critical responsibility of the presenter.

Effective communication is key to good health care and the presenter facilitates communication by watching for cues that something needs to be repeated, explained differently, if the patient is getting tired during long consults and needs a short break, and to ensure that the provider is hearing the full intent of what the patient is saying. In addition, many times the presenter hears something in pre-consult conversation that is important for the provider to know and can remind the patient during the consult to mention the issue. In essence, the presenter acts as a patient advocate during the telehealth consultation.

#### **IV. Lessons Learned from the Field**

The lessons learned are not different for telehealth than for any other service implemented through telehealth technologies. With the exception of not locating stethoscopy in-band (in case the network system goes down, this exam technique can continue, particularly if critical to the diagnosis), few of the lessons learned in implementing telehealth are technology based. Most of the lessons learned fall into the following categories:

- 1) Telehealth is not about technology – it is about the clinical care of patients.
- 2) The development of relationships is the most critical factor in the success of a telehealth initiative.
- 3) Maintaining the human factors present in in-person visits through telehealth access is vital to patient AND provider satisfaction.
- 4) Telehealth business planning is about more than return-on-investment or covering expenses – it is about the moral and economic incentives that health care systems and providers have in reducing the barriers to access to care for remote based populations.
- 5) A well-trained presenter is key to the efficient, effective and accurate practice of the provider via telehealth technologies.

- 6) Operational planning must include an assessment of current practice patterns and identification of variables that must be amended for telehealth. The question is not “How can my practice fit into telehealth,” but rather the question is “What is it about telehealth that must be changed to fit this practice?”
- 7) Telehealth assistance in providing applicable and accessible patient care.

To put it quite simply, telehealth is not about technology, it is about people. Once an organization wishing to embark on a telehealth initiative realizes this important point, the implementation becomes easier. Building and sustaining relationships is the heart of telehealth. Telehealth must be built based on a match of unmet needs and resource availability. Once a need is identified in a rural or remote community, a resource needs to be obtained and matched to the unmet need. Simply using telehealth for the sake of saying one is doing so does not create a successful program. Focusing on bringing human resources together with the needs of other people is an excellent use of telehealth, because it bridges the gap between distance/time and the patient/provider. Following traditional referral patterns is key to success in this area. A thorough investigation of what relationships exist prior to the implementation of telehealth and whether those relationships can be maintained and enhanced after the implementation of telehealth leads to a higher rate of adoption by both referring and consulting providers as well as a high utilization by patients. Forcing “non-community member” viewpoints on how this system of access should work, by members who are not of the community leads to resistance and low utilization.

Adopting a philosophy of telehealth that mirrors services provided in-person is a key to success. Find out what it is about the use of telehealth technology as a tool for care that needs to change in order to fit into the provider’s practice – not what does the provider have to change about their practice to use telehealth strategies. Spend time observing provider’s practices and outlining the organization of care in each specialty practice by individual providers. Analyze that organization of care with respect to providing the same care via telehealth. Mapping out processes/systems and recreating them in a pilot clinic to directly observe how each part of the organization of care might be

delivered via telehealth is a valuable exercise. This systematic delineation of steps includes information prior to the start of the consultation, who collects that information, exam techniques necessary to make a diagnosis, information exchange during the consultation, documentation principles, prescription dispensing, patient education materials needed, and any and all processes for discharge and follow-up. This observational study is imperative in order to make consultations via telehealth time neutral for the provider. The success of programs is driven by this customization of telehealth processes to specialty services. In addition, providers who review procedures prior to implementation and conduct pilot clinics with known patients should be offered help to work out any concerns prior to implementing real consultations. Individual attention to the development and operationalization of clinical services based on the organization of care leads to a higher success rate with providers using telehealth as a part of their daily practice.

The same principles are applied to the remote site. Programs that spend considerable time studying and understanding the patient experience as they access and participate in health care encounters. Patient flow processes including check-in, registration, waiting area locations, exam room setups, medical records flow, follow-up appointing and any process included in the care of the patient at the remote site is evaluated using observational studies. Processes are mimicked as close as possible to in-person care for patients receiving care via telehealth. Patients have the sense that they are coming to their local clinic for care, will be seen in comfortable, traditional exam rooms, and will have their primary care providers close by. Programs should use special framing techniques, color, and lighting to create the in-person experience over telehealth technologies. Minimizing the presence of the technology and focusing on promoting patient comforts leads to high patient utilization rates.

The other lesson learned in this area is the use of a specially trained telehealth nurse clinician. It is extremely important to have a well-trained presenter on the patient end. Provider time neutrality depends on the ability of the presenter to predict what the consultant may need during a consult; the camera skill and expertise of the presenter;

and the creation of “a caring” environment by the presenter for both the patient and the provider.

The final lesson learned is in the area of sustainability. The key to sustainability begins with relationships – recognizing the existing relationships between patients and providers, between providers and providers, and between communities and communities. Respecting and building upon these relationships helps to create a network that adds value to a community’s health system and not one that creates a new system or a duplicate system. Using telehealth strategies as a part of an integrated service delivery network rather than a stand-alone system also supports sustainability. The use of telehealth is not the use of technology; it is the use of tools for access. Access is the availability and accessibility of services to remote based populations. telehealth helps to transcend the barriers of distance and time between people – people who need health care resources and people who can provide those resources (services). Maintaining the human factor in all that we do, both for patients and providers, and consistent support and contact with both referring and consulting providers is critical to sustainability. In addition, telehealth solutions must be easy to use and available right in the provider’s clinical work area. The tools of telehealth should be as indispensable as the telephone or PC to clinical practice.

In telehealth disease management, the program is only as good as the compliance of the patient. The introduction of telehealth in a disease management program increases the likelihood of compliance by increasing access to support systems, reinforcement of patient education, and close monitoring of physiological data collected and transmitted by the patient.

## **V. Useful References**

Aiello LM, Cavallerano A, Bursell, S.E. and Cavallerano J. The Joslin Vision Network innovative telemedicine care for diabetes: preserving human vision. *Ophthalmology Clin of N Am* (2002) Jun 13(2): 213-24.

- Armstrong M and Freuh S. 2002. Telecommunication for nurses-providing successful distance education and telehealth, 2nd Ed. Springer, New York.
- Burgiss S, Sprang R, Tracy J. 2001. Telehealth technical guidelines. [www.telehealth.hrsa.gov/pubs/tech/techhome.htm](http://www.telehealth.hrsa.gov/pubs/tech/techhome.htm), Washington, D.C.
- Bugler D.W. and Reeves C. Interactive internet web sites: a potentially powerful tool for disease management. *Disease Mgt and Health Outcomes* (2002), 7(2):67-75.
- Cherry J.C., Moffatt T.P., Rodriguez C., and Dryden K. Diabetes management program for an indigent population empowered by telemedicine technology. *Diabetes Tech and Therapeutics* (2003); 4(6):783-91.
- Craig J., Loane M., and Wootton R. 2000. Does telemedicine have a role to play in disease management? Patient Centered Healthcare. Adis, Philadelphia, PA
- Cross M. Disease management on the web. *Internet Health Care Magazine* (2000). Nov 50-2: 54-5.
- Couch J.B. 1998. The health care professional's guide to disease management. Aspen, Gaithersburg, MD.
- Dennis R.L. Telephonic disease management is as effective as home visits for disease management in community dwelling heart failure patients. (2001) U of Nebraska, Omaha, NE: 59.
- Dimmick S.L., Burgiss S.G., Robbins S., Black D., Jarnagin B., and Anders M. Outcomes of an integrated telehealth network demonstration project. *Telemedicine Journ and e-Health*. (2003) Spring 9(1):13-23.
- Fox J and Thomson R. Decision support and disease management: a logic engineering approach. *IEEE Transactions on Information Technology in Biomedicine*, (2003) Jan 2(4): 217-28.
- Frost M. Technology enhances disease management. *HR Magazine* (2002), Jan 47(1):69-73.
- Mallarkey G., Ed. Opinion and evidence: disease management. Adis, Hong Kong.
- Meyers L.C. Telecommunications and disease management in the home environment: new strategies to improve outcomes. *Medical Interface* (1997), Jun 10(6):78-83.
- Nesbitt T. 2000. unpublished presentation, Office for the Advancement of Telehealth Grantee Meeting, 2000, Bethesda, MD

Olsen T., Belandres P.V., Coloy D., Forkner E., and Miller G. Using the healthcare management model to explore application of telemedicine to disease management (abstract) (1999). *Telemedicine Journ* 5(1):24.

Powell S.K. 2000. Case management – a practical guide to success in managed care. Lippencott, Philadelphia.

Program *Memorandum*, May 15, 2001, Health Care Financing Administration, Health and Human Service, Washington, D.C.

Regan M. Utilizing an intranet in disease management. *Disease Management and Health Outcomes* (2002), 10(3):147-54.

Scalvini S., Zanelli E. Telehealth Disease Management: A new support for general practitioners in the management of elderly patients. Age and Ageing, 2002, Vol. 31, No. 2; p. 153.

Schlachta L. (2003). Disease management via telehealth: technology tools for the year 2005. Proceedings of the Pacific Medical Technology Symposium: PACMEDTek '98 IEEE Computer Society Press, LosAlamitos, CA

Shanit D; Cheng A; Greenbaum R A. Telehealth Disease Management: supporting the decision making process in general practice. *Journal of Telemedicine and TeleCare*, 2002. 1996. Vol 2, No 1; p. 7-13.

Zander K. Ed. 1995. Managing outcomes through collaborative care. AHA.



## Electronic Medical Records for Rural Health Systems

**Authors:** Pamela R. Wirth, Susquehanna Health System (SHS)

Angela N. Haas, MD, Susquehanna Health System, Williamsport, PA

### I. Introduction

The goal of this technical assistance document is to provide an overview of the critical success factors to be considered when implementing an Electronic Health Record.

#### **Purpose:**

For the purposes of this document, SHS considers an electronic health record to be a crucial part of a telemedicine project, as it contains all the information needed to treat the patient. At SHS all records are either automated from the beginning of the treatment of the patient or converted from a paper based record into an electronic health record.

#### **Definitions:**

- EMR– electronic medical record, EHR-electronic health record, CPR - computer-based patient record, all are acronyms used to define and refer to an electronic version of a patient's record. Each one has its own definition and each one is often used interchangeably.

*SHS has adopted the definition published by the consulting firm the Gartner group, which is as follows, however SHS uses the acronym EHR:*

The Gartner Group

**A computer-based patient record (CPR) contains patient-centric, electronically maintained information about an individual's health status and care, focusing on tasks and events related to patient care and optimized for use by clinicians. When designed correctly, it meets all of an organization's clinical, legal and administrative requirements for the clinical process. (Administrative requirements refer to the handling of patient charts, not financial administration).**

A CPR's key role is to improve the delivery of healthcare, customer service and quality outcomes by supporting caregiver's needs. CPRs must eventually support the delivery of care across the complete continuum of service as well as delivery modalities. CPRs are the essential foundation for the future medical management capabilities that eventually result in effective data sharing between all healthcare stakeholders.

- Electronic Health Record - A newer concept of an automated health record. The EHR concept begins by highlighting the comparative difficulty of achieving a true, longitudinal, completely paperless, interoperable CPR. EHR offers instead the concept of many components of automated capability to support an enterprise requirement. It is implemented in steps, based on the return on investment that can be achieved within an organization. Components include clinical workstations, data entry systems, templates or forms, communication (wireless, hard-wired, and/or Internet-enabled), speech recognition, transcription, security, Master Patient Index (MPI), order entry, results reporting and decision support. See also CPR and MPI. *Provided by: HIMSS – Reference to the complete listing of components that are essential requirements of an EHR as defined by HIMSS - <http://www.himss.org/asp/ContentRedirector.asp?ContentID=41613>.*
- WAN – Wide area network. Interconnected devices sharing resources in a large geographic area.

- HL7 – Health Level Seven. One of several ANSI-accredited Standards Developing Organizations (SDOs) operating in the healthcare arena, with a protocol domain in the areas of clinical and administrative data. Also, a Designated Standard Maintenance Organization (DSMO) under HIPAA, pursuant to §162.910, together with Accredited Standards Committee X12, Dental Content Committee of the American Dental Association, National Council for Prescription Drug Programs, National Uniform Billing Committee and National Uniform Claim Committee.

*Provided by: HIMSS*

- VPN – Virtual Private Network. A secure private data network established over the Internet
- LAN – Local area network. Interconnected devices sharing resources in a small geographical area
- LATA – Local Access Transport Area
- HIPAA – Health Insurance Portability and Accessibility Act
- PKI – Public Key Infrastructure. Technology, facilities, people, operational procedures and policy to support public key-based security mechanisms. It is an enabler for these encryption and digital signatures. *Provided by: HIMSS*
- Biometric Security Identification - A measurement of a unique physical feature or repeatable action of an individual (e.g., hand geometry, signature, retinal scan, iris scan, fingerprint patterns, facial characteristics) that can be used to identify one person from another. *Provided by: HIMSS*
- ASP – Application Service Provider. A third party that manages and distributes software-based services and solutions to customers across a wide area network.

Electronic Health Records (EHR) are seen as a very important part of the Healthcare setting, however not many organizations have successfully implemented an EHR until recent years. The past 5 years have seen the trends turning more towards clinical automation and the EHR is a computerized application that most organizations have on a strategic listing of IT applications to be installed.

Below is some trend data that illustrates the movement towards an electronic health record. *This data was extracted from the 11<sup>th</sup>, 12<sup>th</sup>, 13<sup>th</sup>, 14<sup>th</sup> & 15<sup>th</sup> Annual HIMSS Leadership Surveys.* At first glance this data suggests that as time increases so does the percentage of EHRs planned and/or implemented. However, it is difficult to infer that such a correlation really exists because of the decrease in the number of CIOs responding each year, with the exception of 2004.

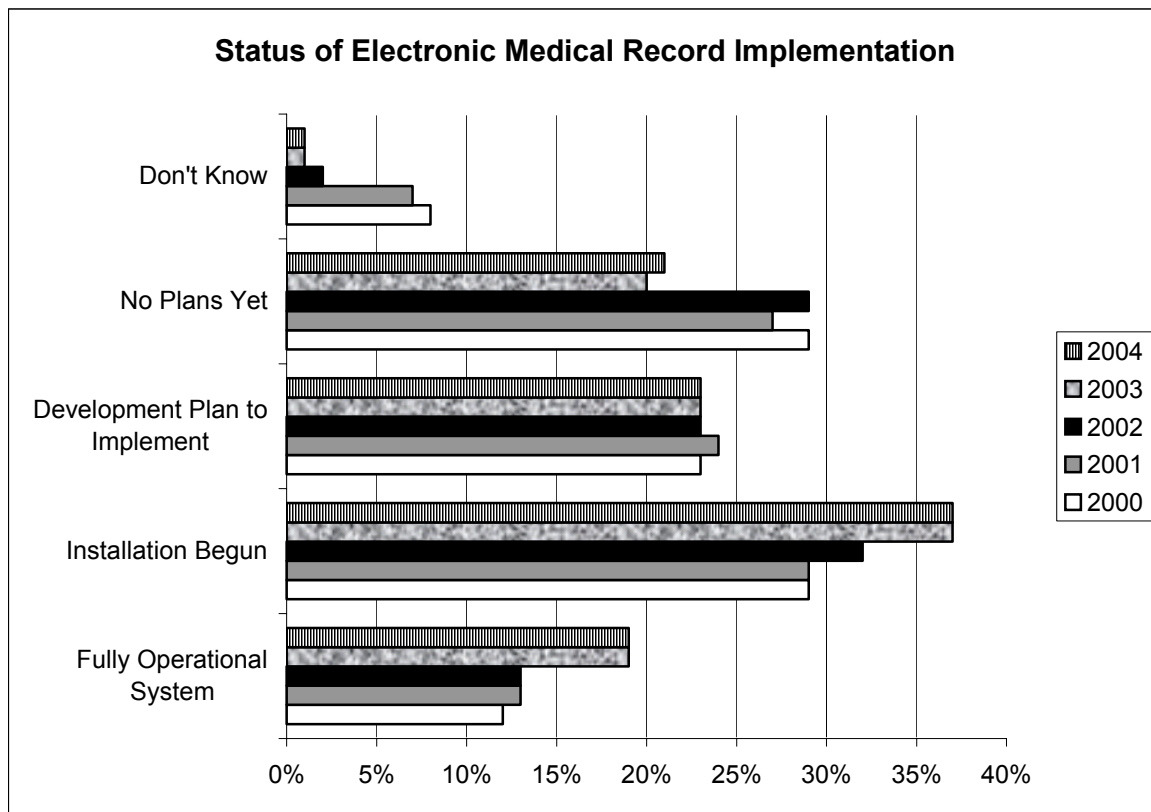

	2000	2001	2002	2003	2004
<b># of CIOs Responding</b>	858	688	355	291	307
<b>% with EMR implemented</b>	12%	13%	13%	13%	13%
<b>% with EMR in process</b>	29%	29%	32%	37%	37%
<b>% planning for an EMR</b>	23%	24%	23%	23%	23%
<b>% with no plans for EHR</b>	29%	27%	29%	20%	20%
<b>Don't Know</b>	8%	7%	2%	1%	1%

### **Case Study Background**

Susquehanna Health System (SHS) has collaborated with several other hospitals as well as the entire physician population of the area to deploy an electronic health record that contains many components of clinical patient information. This allows caregivers to treat patients from any point in our continuum of care, whether that is inside the walls of a facility, a physician's office, or physician's home.

In July 1994, an alliance was formed among three area Pennsylvania hospitals signaling the beginning of a new era in healthcare for the region. This alliance, called Susquehanna Health System, brought together The Williamsport Hospital & Medical Center, Divine Providence Hospital and Muncy Valley Hospital, along with their subsidiaries into a fully integrated healthcare System. In 1997 SHS entered into a contract with the Laurel Health System in Wellsboro, PA to provide them with Information Technology staff and services. That contract was so successful that it was recently renewed to 2007. In 2001 SHS entered into a similar agreement with the Jersey Shore Hospital in Jersey Shore, PA to provide Information Technology services. In 2004, a similar contract was entered into with The Susquehanna Valley Rural Health Partnership which includes Bucktail Medical Center in Renovo, PA which is a small critical access hospital. These contracts had made it possible to begin to share patient's medical information among unaffiliated Health Care Providers allowing for more timely patient care.

Over the past 8 years SHS has been developing the application database of an electronic record for the patient population it serves. To date it contains more than ten years of information ranging from laboratory, pathology, and radiology results and images, echo cardiology reports, cardiac catheterization lab studies, nursing documentation of patient assessments and histories, discharge summaries, operative reports, history and physicals, medication lists, ER documentation, patient demographics, and EKG's. This information is currently available via a private secure web portal for all SHS physicians. In addition to the acute care electronic health record, SHS has a standardized ambulatory electronic health record that is in use at over 60 rural health care provider locations.

In rural areas, like this, access to comprehensive information is imperative to reducing medical errors and enhancing patient care.

SHS has expanded its partnership with several regional organizations to which it currently provides information services to provide additional access to a regional patient medical record. SHS has a long-term relationship with Laurel Health System (LHS) and a more recent relationship with Jersey Shore Hospital (JSH) in which SHS provides all information systems products and services. The organizations also share a large population base that results in many referrals between organizations. The area served is predominately rural and access to information is a constant challenge.

SHS actively involved the Medical and Clinical Staff, Board of Directors, Local Business, the Community and our Payors in the education process involved with the adaptation and implementation of the electronic health record as the tools we are providing caregivers to allow more accurate and timely access to patient information. This involvement garnered tremendous support for the Susquehanna Health System Clinical initiatives. SHS felt that it was equally important to cultivate the cultural changes that would need to occur in order to make this project successful creating openness to redefined workflows and improved outcomes.

## II. Step-by-Step Guide to Creating a Successful Program

First and foremost it is crucial to realize that this type of computerization is often the most complex, costly and difficult that any healthcare organization can deploy. It is often met with great resistance because of the nature and level of change that was required. It can take many years to fully implement. Needless to say, without vision and leadership by a senior executive and medical staff leaders of the organization, a project of this nature can easily fail. It is also one of the most, if not the most, important clinical computerization projects that an organization can implement.

This type of project is not one that is easily replicated; however, many pieces of the process are. While creating a step-by-step manual on how to go about this process is not feasible, what SHS has done is share many things to consider and lessons learned throughout the implementation of an EHR.

### Issues/items to consider when implementing an electronic health record

There are various models of EHRs today. The components are similar but they are generally used by disparate personnel and in different settings. Some of them and their uses are as follows:

- Acute Care – Used for documentation purposes for patients while they are a patient in the hospital. This model can eventually replace a paper chart. This includes documentation of nursing (vital signs, medication administration, and physical exam), respiratory therapy, physician orders and notes, nursing assistant duties, physical therapists and pharmacists.
- Ambulatory – Used within a clinic or physician office to replace the paper chart that a physician would use to document the patient findings and condition. There are many variations of adoption of this model. One is a complete paperless chart system. Another is when the physician simply uses electronic prescription writing and maintains an electronic database of an individual's prescription history. Obviously, the more the physician documents, the more complex the

documentation will become. At SHS, nurses document phone calls, medication refills, track immunizations and vital signs. SHS physicians document the patient encounters using templates; order ancillary services electronically; and can run reports on patient populations. The more value an electronic record has, the more complicated the electronic record typically becomes. It should be noted that physicians who are not computer literate may become overwhelmed by the perceived complexity of the record.

- Long-term Care – Used within a long-term care facility or skilled nursing facility to document patient care. One of the variations of this model is to use touch screen capability. Utilizing pictures rather than words allows workers to easily document the services that could be rendered to the patient by selecting the pictures from a user friendly menu. This allows the caregiver to touch the screen showing the service that they are providing and thus documenting that the patient has received the service. This variation allows for the varying skill levels of the staff that are often problematic in this type of facility (some not being computer literate or able to read and write effectively).
- Home Health – Used to document the care of a patient while under the services of a home health professional. This is usually completed by using a laptop type of device in the patient's home while the service is being rendered.

As described above there are many different models, they are often stand-alone systems that do not exchange or share information between systems. This causes a lack of continuity for the care of the patient and may cause the ordering of repetitive tests or possibly delaying the treatment of the patient when information could have been readily available if the information was shared between systems. This calls for a new model called the integrated model. This is the model that SHS is implementing as a telehealth project.



### Definition of project scope

Before beginning the implementation of an EHR, consider developing a working group of individuals who are familiar with the current paper process. Representatives from IT, Health Records, Medical Staff, Ancillary departments, Nursing, and management are examples of individuals who can assist in this process.

It is helpful to flow chart the paper process and determines what pieces of the chart, if any, are already computerized. Identify what modules would be most beneficial if computerized to provide patient care. Also, take into consideration the ease with which these modules could be computerized as well as the cost.

Sometimes you run into political “sacred-cows” that are often best left until later in the process no matter what the benefit to the project would be. An example of this could be a personnel issue, or an issue within the area that you are automating that would cause additional disruptions within the department that may best be dealt with at another time. The SHS staff has found that in this case it is always helpful to get some wins for the project before tackling the difficult issues. SHS staff identifies things that have great value, but require little effort for success. The staff considers these accomplishments as “trophies”. When implementing a project as large as an electronic health record, it is helpful to have several trophies under your belt early on in the implementation process. This makes the project team feel successful early on, and usually is motivating for the group to then tackle larger projects.

It is best to have a plan constructed on paper before the task of selecting the system you plan to implement. This plan can then serve as a roadmap to guide you through the process. This plan must be multi-faceted and build upon the strategic direction and philosophy of your organization in regards to clinical computing and the deployment of the HER. As with any map you can choose to turn one direction or another based on the priorities at any given time.

**Software** (functionality that is required) is one of the first things that must be considered when implementing an EHR. The decision to build or buy is one many struggle with.

Electronic health record software is very complex and must be constantly maintained and updated. In many rural communities hospitals and/or healthcare providers have a difficult time recruiting and retaining talented Information Technology staff. Therefore, it is advisable to buy a vendor-developed and supported product rather than building a system from scratch. Some of the modules that are standard in a vendor-developed product are:

- Results (a radiology report or laboratory values).
- Ambulatory medical record (physician office record that contains chart notes, medications, patient problem list, history, etc.).
- Scanning (the scanning of various non-computerized documents into the software).
- Documentation (the ability to type various types of notes and or template notes).
- Nursing (this could include items like Health History, Nursing assessments, progress notes, etc.).
- Other care provider (charting from areas like physical therapy, social services, dietary).
- Physicians (this could include physician order entry, inpatient consults, progress notes, etc.).
- Pharmacy Information, such as electronic prescribing, pharmacy profiles, decision-support tools, adverse drug-drug, drug-allergy, drug-food and drug-disease-checking modules, bar coding and drug administration.
- Applications that allow access via the Web are becoming more and more popular and are considered easier to implement both from a technology standpoint as well as from the end-user training perspective.

**Interfaces** - In many cases there may be several vendors involved. This requires that interfaces be developed. Many systems today support industry standards such as HL7 that make interface development easier than in past years. In essence what this means is having a standard dictionary for all computers so that the terms are defined and communicated back and forth from computer to computer in a manner that makes it easy to use and pass data between systems. An interface engine is another tool that is often effective. It allows the provider to control and develop the interfaces.

**Standards** – Industry standards are constantly being updated and in the past few years have been well researched by many organizations. Today the federal government as well as several organizations that are industry leaders in healthcare information technology have either adopted and endorsed healthcare information standards, such as ICD9 (coding used by medical records professionals), HL7 (Health Level Seven is a programming language used to create interfaces), DICOM (is a standard used to interface digital equipment like radiology equipment to computers), etc. This is just the beginning of the adoption of standards. With the advent of HIPAA, there are now standard billing transactions such as ANSI 837. It is very important to address standards with the information vendor that you choose and ensure that it can and will meet all the necessary standards as required.

**Interoperability** - A key to interoperability is the use and adoption of standards. Interoperability is the ability to “talk” from one information system to another and to share data. As more and more clinical information systems are installed in healthcare organizations across the country, it will be necessary for these systems to talk to one another and to share data to provide the best in patient care.

**Security** – This is extremely important topic as security is software that protects the confidentiality of the patient’s electronic health record. This area can be extremely complex which often translates into difficulties for the end-user. If the security solution that you select is difficult for the end user to use, they may become very dissatisfied and discourage their use of the computer.

Security also becomes of paramount importance due to federal regulations and regulatory bodies such as HIPAA, the various state departments of health, JCAHO and the rules that they enforce in regards to accessing patient information. Health care providers have the responsibility to protect patient information.

HIPAA - HIPAA is a driving force in the standardization of healthcare transactions as well as enforcing the privacy and confidentiality policies that have been in effect in healthcare organizations for years. While there will be challenges in assuring privacy and confidentiality of electronic health records, most vendors are well positioned to handle these needs. Common sense leads one to believe that it is more difficult to manage the human component of HIPAA rather than the technological component.

Security options need to be planned and tested well in advance of the implementation of the application. Do not underestimate the length of time needed for this task. There are many types of security protection and authentication programs that are available. Several should be evaluated for their effectiveness within your own organization. Some types of security are as follows:

- Encryption.
- Tokens (this is a device that can resemble a key fob, it usually has a series of computer generated numbers that change every 60 seconds and become the password for the user to authenticate their identity).
- Biometrics
  - Fingerprint Scans (there are multiple types of scans, that basically record the minutiae points of your fingerprint and are used to identify an individual and authenticate them into a software application).
  - Retina Scans (this is a scanned image of your retina that is used for authentication purposes as well).

- Digital Certificates (this is generally a piece of software that is used to authenticate a user and often is associated with a string of numbers).
- Passwords (this could be user defined codes or system defined codes that are used to authenticate a user into a software application).

**Hardware** - Hardware is a major implementation investment and can be dependent on the product that is implemented. It is very important to work with the vendor when selecting hardware. Many times hardware selected that a layperson would consider the same, will not offer the same functionality as the hardware used/recommended by the vendor. The following are several options for use with an EHR:

- Client Server applications normally use a personal computer as the interface for the end user. These types of systems can be cumbersome to support and maintain if the client device requires frequent updates. Again, each system is specific to vendor requirements and may or may not require extensive support and maintenance.
- Terminal Based - For the most part, these types of systems are considered legacy systems which use dumb terminals. These are the least attractive to install today and have severe limitations for end-users. However, on the positive side, most of them work really well and once the user is accustomed to using the device and the system the learning curve diminishes significantly.
- Hand Helds – Personal Digital Assistants (PDA) are becoming more and more popular. Each device has its place in the deployment of an EHR and the PDA is best used in a situation where a great deal of data does not need to be viewed on the device. Because of the limitations of the screen display, a good use for a device such as a PDA would be the entry of patient's vital signs.
- Wireless devices – Laptops and other types of computers can be deployed via a wireless network. This can be a large expense for the organization but can also

have a rapid payback by creating an environment whereby the caregiver has the ability to document and review the patient information at the bedside.

**Vendor Selection** is one of the most important decisions made at the onset of the project. It is important to understand the vendor's vision and strategy and to make sure that it matches that of your organization. Many viable projects between good vendors and providers fail because of a lack of alignment or relationship between the vendor and the healthcare organization.

When evaluating software it is also key to evaluate all the offerings a vendor brings to the table such as support, hardware, consulting services, etc. It is a very important step to acquire and check company references as well as to site visit one or two clients to see the product in operation and evaluate their satisfaction with the vendor.

It is important to review packages from several vendors for comparison and negotiating purposes. A successful negotiating technique is to combine projects from multiple organizations into a single larger contract bid.

Features related to the product is important in the selection, but should not be the deciding factor in a project of this nature. An example of this may be each vendor provides a screen to view progress notes, one may be green and the other blue. Many products are at the same development life cycle and all products today offer similar features.

**Computing Methods** - ASP vs. in-house computing has been a long-standing debate among Information Technology professionals. There are advantages to each method of computing and we believe that this really comes down to a matter of personal preference. There may be cost savings and advantages to each model. It depends on each individual organization and its current and future needs. An ASP model allows the application to be hosted at the vendor site. This allows the vendor to be responsible for hardware, operating procedures as well as upgrades, fixes and other software changes. There must be a network connection between the vendor and the hospital. If the connection goes down, there is no product available to the hospital. A "mission critical"

piece of software such as an EHR cannot allow for downtime. This places a large responsibility on the vendor to ensure connectivity. In addition, it is the responsibility of the vendor to ensure proper hardware to maintain the product. In-house computing gives the hospital system full responsibility for connectivity, upgrades and other software changes. However, the staff must be capable of maintaining software, hardware and upgrades.

A plan must be in place for potential downtime situations, although difficult users are much more understanding if they know what to do in this type of a situation and know how to execute the plan. It is advisable to create a very detailed downtime plan that incorporates the use of paper during the period that the systems may not be available.

SHS serves as an ASP for all of their organizations including physicians as well as the two independent Health Care Systems they serve. All data systems are run out of a centralized data center using the same hardware and a combination of centralized and decentralized databases. All data within the databases is secure and owned by the providing organization. Service Level Agreements, which act as a contractual document, are in place with both the internal departments they serve as well as the external organizations. The service level agreement defines responsibilities of both parties as well as response times. The contracts take into consideration legal issues such as “hold harmless” clauses and “force majeure” which are standard in most contracts. Special care is taken to document and ensure that appropriate down-time plans are in place at each organization as well as redundant computing.

**Telecommunications Challenges** - In rural healthcare there is often more than one organization involved in the use of the electronic medical record. These can be physician offices, clinics and multiple hospitals. In many cases there are large distances between these organizations that can pose very special challenges such as different types of telecommunication services as well as many different carriers that may need to be involved. If you do not have the expert internal resources necessary you should use an infrastructure network consultant. This person should have the skills necessary to

design the network and negotiate with phone companies when multiple institutions are involved.

Building a wide area network (WAN), if there is not already one in place, may be one of the largest expenses involved with this project. Without this network in place it will be very difficult to deploy the systems to multiple locations and or providers. The WAN is a necessity for achieving good acceptance of the product by the users. The size and speed of this network will be very important as this may directly affect the speed and usability of the application for the end user. If the application is not readily available or is slow, then the users may not adopt the use of the system.

Lesson Learned – System Availability and system performance. The best system in the world could be implemented, but if it appears to be too slow or unavailable to the users. Pay close attention to the responsiveness of the system by observing some users doing their jobs. Users can become easily discouraged with a new system giving it bad reputation that may be difficult to overcome. Ensure that you have proper vendor support for system performance as well as a contractual commitment for computer response time.

An electronic medical record implemented in a single entity is one that will have limited use. While it may be used within the walls of the organization it will not be as effective a tool as it could be if available in multiple locations. Even in a stand-alone hospital or physician's office, there are often times when the system would be very effective in treating patients if available for use in either the physician's home or office or in other facilities. This is an important part of the planning required in the implementation.

Multiple entities in a rural setting can be a very complicated matter that may require the assistance of a consultant. Different states have different telecommunication regulations. In many rural areas, well-known telecom vendor services may not be available. In one circumstance that we are aware of, two healthcare organizations located within a 60-mile radius (yet very mountainous area) required up to 5 different types of network connections and crossed more than four different LATAs.



Reaching out to clinics and physicians can occur in many ways. It could be as simple as a dial-in number for their computer to connect to, a simple URL address that allows access to the system, or a direct connection to their home or office.

**Training** - One of the most important issues in implementation of an EHR is training. SHS has found many users to be very computer literate and just as many that have never used a computer before. When migrating to a personal computer based system, it is important to evaluate what percentage of your users will need computer training before you can begin to implement the training for the EHR. Local high schools, colleges or universities are excellent partners for basic computer training because of their access to large training rooms with multiple computers and pre-designed introduction courses.

Training sessions should be designed to meet the needs of the users, with a list of objectives and strict adherence to the time schedule. In addition, the sessions should be held during times and in places that the trainees would be able to attend. For example, it would be counterproductive to hold a training session for physicians at 10 AM – a time when most physicians are seeing patients in the office or attending to other patient care needs. SHS conducts physician training at 7a.m., noon or after 5:30 p.m.

#### Pros and Cons of Training Methods

- One-on-one training
  - Users at a basic computer skill level usually learn better in a one-on-one training opportunity. For those who are not computer literate, sitting in front of a computer can be quite intimidating. This type of training allows for the training to proceed at a speed that is comfortable for the trainee. Physicians or executives who are not computer literate are excellent candidates for this type of training. This type of training is very time and resource intensive for the trainer and IT staff. However, in a situation where the trainee is imperative for the success of the program this type of training should be considered. When implementing a system that requires little training and oversight, SHS has found

it useful to have the training group make rounds. The group visits the user areas – such as a nursing floor – and trains the physicians, as they are available.

- Classes
  - For users with essentially the same skill level, classes can be the most effective. It is very effective to do some pre-screening or testing of the users in advance to place students with similar skills in the same class. A trainer-to-trainee ratio of 1-2: 7-10 works best, at a bank of computers. The hands-on training is very important, as it allows users to make mistakes and to explore the program at their own pace. Classes usually contain trainees at a range of skill levels. If at all possible it is helpful to have the trainees grouped by skill level, but because of limited training sessions this might be difficult to arrange. Less skilled users should be asked to identify themselves early in the class, so they can obtain some individual help as needed. More skilled users are tempted to explore the program usually ahead of the class. It is important the trainers are aware that all users are completing the objectives set at the beginning of the course. This type of training can be IT-staff intensive, especially if many users have to be trained. Finding the space for a dedicated training room or area can also be challenging for many organizations.
- Conferences
  - Training a large user group, such as physicians, in a short period of time is one of the most challenging obstacles when implementing an EHR. SHS found that all-day training sessions during a conference to be most effective. SHS offer Continuing Medical Education (CME) credits, speakers on related topics and a schedule that repeats all day long in a location that is off the hospital campus. In addition, SHS offers a gift (one year it was a PDA) for attendees of 4 sessions or four hours of CME credits. This method allowed the SHS staff to train 200 physicians on the first day of our EHR use. This method is very staff

intensive, from planning to fund raising (if necessary to pay for the gift, CME credits, meals, etc.) and requires a team to plan and staff the conference. This model also works well for large groups of nurses or other large groups who need to be trained. Training can be all day, with classes starting every half-hour or hour as needed, and can be offered for alternative shifts (see attached example).

## Implementation

- Champions
  - For every system implementation, it is important to have a champion. This person's job is to be a cheerleader to the user group and IT staff, and to promote the product to the user group. The champion should be a clinical colleague, and not an IT staff member – a nurse for nursing staff or a physician for physician groups. This champion should be politically savvy, and able to negotiate the minefields of hospital committees and those who would present roadblocks to the implementation or use of the product. The champion is usually involved in the selection of the product, and works with the IT staff in the project design and implementation.
- Pilot
  - The pilot group is the best way to achieve user buy-in before the implementation actually occurs across the entire user population. This group should be made of those who will meet when necessary, give feedback both positive and negative in a timely fashion, and report problems appropriately. A pilot group member does not need to be someone who is computer literate, but should be someone who is willing to learn. At times, a pilot group may be a patient care ward in a hospital or an entire physician office. This strategy is helpful to quantify the impact on caregivers across the health care continuum. Successful pilot groups are not necessarily using a product successfully, but instead they point staff to problems, or to bugs in the system.

## How to implement the product

Implementation of a product is a very complicated task. One of the first questions SHS always asks is whether SHS wants to implement a few functions at a time or all at once – which SHS fondly calls the “big bang” method. Important questions to ask include:

1. Are the functions intimately related so that it would be impossible to implement them separately?
2. Are any of the functions critical to patient care?
3. Would the delay of implementation of a function negatively impact patient care?
4. Is the product intuitive enough so that minimal training would allow users to use the system easily?
5. Would the implementation of the whole product change workflow so dramatically that patient care could be compromised?

There are benefits to both options for implementation. Products that are simple and intuitive, such as a web-based system, have effectively been implemented with little to no training. Implementation of a product, such as physician order entry, which would require hundreds of users, hours of training, complete workflow redesign and would have a high impact on patient care, might be best implemented in phases or phased in by patient care nursing floors.

During the implementation phase, it is extremely important that support is readily available for users at the time they need it. Users who are frustrated because they cannot complete the task they started will not continue to use the system.

**Lesson Learned** - “Super users” – It is important to develop users who have had extensive training, thus called super users. It is their responsibility to offer support and training on the spot for others, this is imperative for several weeks after implementation.

Pamphlets or cards with shortcuts at every computer are also helpful for a quick reminder. Finally, someone needs to be available by phone to talk the user through any issue. Resources need to be available 24/7 for the implementation phase.

### **Communication**

Communication of the implementation plan is the responsibility of all involved. The plan should be disseminated in a timely manner, with as much information regarding training and other important issues as possible. It is important not only to make those who will be using the product aware, but also those who will be impacted by the new product should be identified and informed. Most importantly, delivering the message over and over will make sure that a majority is at least vaguely familiar with the change.

### **Staffing**

The SHS IT Department philosophy is that one or two primary staff should be responsible for that product. Ideally, they are responsible from the beginning for building or developing the product. They are part of the project team, working with the champions and eventually pilot users. The staff member helps to develop a user-training plan, and is part of the training team. During implementation, they are with the users “in the trenches” to help with training and support.

SHS has been most successful with hiring users to be part of the IT team. They have credibility with the staff, and are considered “one of them”. The IT staff member who is a nurse can test systems efficiently, trouble shoot with relative ease and talk with nurses in their own language.

Clinicians can be outright reluctant to discuss things with IT staff because the clinician is embarrassed about his or her lack of IT knowledge. Employing nurses or unit clerks on the floor seems to be less intimidating to physicians in the EHR training process.

## **III. Lessons Learned**

1. Champions are a must. A clinical user who is the champion will be your biggest ally and a resource for years to come. A successful implementation will always have struggles and challenges and unexpected events. Having a champion with a positive attitude will help guide the team through the rough times, and keep the team focused on the task at hand.

Take care to consider the use of physicians as champions in your organization. It may be well worth the cost to consider employing part time or for a fee a Medical Director for your projects. At SHS we pay an annual fee to employ a physician in this role. It has paid back multiple times with the buy in that has developed both from this physician as well as support from the entire medical staff. This has enabled us to implement projects in a much more timely fashion with less resistance from the medical staff. At present SHS has engaged 5 physician advisors for 1 year to complete our implementation of Computerized Physician Order Entry. For the time they commit to this project, they will receive a fee that is paid upon completion of milestones.

2. Conferences are effective implementation tools. Training a large number of users in a short period of time is invaluable. Support for these users must be planned very deliberately.

SHS has held five bi-annual conferences on Healthcare Computing. Each one is better attended than the last and with higher satisfaction scores. In 2001 SHS awarded over 2000 CME credits to physicians attending this event. In 1999 over 300 physicians were trained on a new system application in less than 8 hours.

3. Hands on training - Whether it is one-on-one training, or in a training room in front of a computer, nothing can compare to learning how to use the system by using it.

Physicians care about the time it takes them to complete their tasks. SHS has had physicians measure the amount of clicks on a mouse that it takes to complete their documentation. When implementing systems SHS makes it a point to show the physician that it takes less clicks and time. The trainers also point out all of the benefits (tangible) that they receive by using this system. In other words they care about "what's in it for me"

4. Value Added – Hospital staff and departments will never invest the time and energy necessary to implement an EHR if there is no value identified with the changes.
5. Security options – there is an ever-changing world of security options available. SHS learned that it is best not to commit solely on one method until all the options are more established. SHS stood firm on secure id tokens only to discover that there are better methods becoming available every day. At this point SHS is using a combination of secure id tokens and biometric mice.

In 2001 SHS deployed over 300 biometric mice to the physicians at SHS as a security method. They replaced a PKI security token which required the physician to enter their user number, a password and a 6 digit code on the token that changed ever 60 seconds. While very secure it was cumbersome to use and the physicians often lost or broke the tokens requiring frequent replacement. The new biometric mouse was less expensive to maintain than the tokens and simply required the physician to put their finger on the mouse and be scanned. It immediately launched them onto the network and then logged them onto all of the applications that they use on a regular basis. All with a single touch on the mouse. The physicians were not only thrilled with the technology but with the ease of use and the reduction in steps and time to logon to the systems.

6. Collaboration – There can be a huge value in collaboration whether it is between a hospital and many physician groups or between several organizations sharing a single information system. Collaboration has been on of our largest successes as well as a huge cost savings for all involved.

The collaboration that has been established between Susquehanna Health System, The Laurel Health System in Wellsboro, PA and Jersey Shore Hospital Jersey Shore, PA has resulted in savings of over \$1,000,000. This is just one factor of the relationship to be considered, a more trusting and well-honed partnership has formed between the organizations in other areas besides Information Technology.

7. Vision and leadership – An organization without the vision and leadership of senior executives is like a ship without a compass. The IT department alone cannot guide this process. The Chief Medical Officer, Chief Nursing Officer along with other clinical executives must see value, and have the vision to keep the projects on track.

8. Targeting early “wins” – It is easy to get hung up on trying to make a huge project go live all at once. SHS found it motivating for the group to pick “low hanging fruit” first, get a success under the group’s belt, and then move on to a bigger project.

While waiting for web technology to be readily available for our nurses and physicians SHS made a strategic decision to deploy a web portal allowing access to legacy application via the web with many added benefits such as an on-line library for their use. The project took 6 weeks from beginning to end and made a huge impact on the satisfaction of the end-user. It is important to realize that sometimes-interim solutions should be deployed to maintain the positive attitude of your user community.

9. There is always a cost associated with re-engineering. Depending on the organization and their ability to design and coordinate a re-engineering project within their own organization, the cost could be minimal, however, if the organization does not have that expertise in-house there could be a considerable expense related to that re-engineering and should be planned for and budgeted appropriately.

Think outside the box from an implementation standpoint. Try and be creative and think about re-engineering workflows and tasks. Do not simply try and automate a paper process or to recreate the exact system that you may be replacing. Take advantage of this wonderful opportunity to rethink the way business is done.

At SHS, upon implementing an ambulatory EHR for several physician offices it became apparent that the clinicians (both nurses and physicians) felt very uncomfortable giving up their old workflow. In most cases they received their medical training to complete tasks in a certain manner and they had been practicing that way their entire career. Because of this and some unease with the computer they became easily frustrated and discouraged. At one point, SHS had several physicians ready to give up. The approach that SHS took was to deploy our clinical IT nurses to the office to help when needed, booster skills and confidence with the computer and offer suggestions for use. SHS also began meeting weekly with the physician and office staff to review progress and issues. It was a long road, but after a full year the physicians were able to see the value that the EHR provided and would never give it up. (It took nearly a year for all of their patients to cycle through and be documented on in the computer system) The following offices that were implemented went much quicker and easier with this approach from the beginning; however the learning curve can still be long – but in most cases well worth the effort.



10. Never underestimate the learning curve a clinician faces when not only learning a computer application, but when changing their workflow. This can be a very difficult transition, but it can be overcome with the appropriate care and dedication to the project.

### **Costs and Funding Sources**

This is an area of great debate in the Industry today. Many organizations require complex Return on Investment calculations prior to the consent to begin such a project. Often times this is difficult to prove in such a complex area. There are definite savings that can be attributed to an EHR and in fact in the ambulatory arena SHS has completed ROI studies that show a return with a 1 year period if the physician had dictation expense prior to beginning the implementation of an HER. The acute environment should experience significant savings in reduction of errors, elimination of duplication of testing, clinical rules implementation to regulate the use of expensive drugs and decrease in turn around time for patient care.

SHS chose to take a different approach to this implementation. SHS considered this implementation a cost of doing business, one that is necessary for the care providers and one that is necessary to provide excellent quality care for the patients. Each organization must reach their own philosophy when it comes to ROI for electronic health records.

None the less, the costs associated with the implementation of an EHR can range between tens of thousands to millions of dollars depending on the scope and size of the implementation. Whatever the cost, it is undoubtedly a very large investment for the organization implementing it.

SHS was fortunate enough to have a development/partner relationship with a vendor that provided discounts for software and professional services in return for clinical knowledge and software validation. This provided an opportunity to stretch the dollars to complete more implementations for less.

In order to assist with the costs, there are sources where alternative funding can be sought. Some of these resources are listed below. These resources are constantly changing and being updated and must be researched frequently to be optimized.

USAC (Universal Service Administrative Company) - This may not be a large source of funding, but can assist with reducing the ongoing telecommunications cost involved with the operational costs of a wide area network.

Grants – There are many types of grants that are available for rural healthcare as well as for information technology many of them are listed below in the resource section.

Collaboration with others – Never underestimate the value that can be achieved by collaboration. Make sure that the vendor is fully aware of any such collaboration to ensure that you aren't breaking any contractual commitments.

### **Resource Listing**

[www.himss.org](http://www.himss.org)

[www.himss.org/asp/issuesbytopic.asp?TopicID=15](http://www.himss.org/asp/issuesbytopic.asp?TopicID=15)

[www.cpri-host.org](http://www.cpri-host.org)

[www.tepr.org](http://www.tepr.org)

[www.gartner.com](http://www.gartner.com)

<http://ccbh.ehealthinitiative.org/default.msp>

<http://tie2.telemed.org/funding/search.asp>

<http://usadc>

[www.ahrq.gov](http://www.ahrq.gov)

[http://www.ntia.doc.gov/top/whatsnew/whatsnew.htm#update\\_on\\_2002](http://www.ntia.doc.gov/top/whatsnew/whatsnew.htm#update_on_2002)

<http://grants1.nih.gov/grants/guide/rfa-files/RFA-LM-02-001.html>

[http://www.raonline.org/info\\_guides/funding/capital.php](http://www.raonline.org/info_guides/funding/capital.php)

[www.healthmgttech.com](http://www.healthmgttech.com)

[www.healthdatamanagement.com](http://www.healthdatamanagement.com)

[www.healthcareinformatics.com](http://www.healthcareinformatics.com)

<http://dmi-www.mc.duke.edu/dukemi/acronyms.htm>

## Chapter Seven

---

### HIV/AIDS

**Authors:** Karen Rheuban, MD, University of Virginia  
Richard Settimo, MA, University of Virginia  
Brian Wispelwey, MD, University of Virginia

**Contributing Editor:** Jana Katz, MBA, University of California at Davis

#### I. Introduction

The provision of care to HIV infected patients requires a careful, thoughtful and coordinated integration of traditional healthcare services with specialty care provided by the HIV specialist. This monograph, will provide an overview of the University of Virginia (UVA) experience providing telehealth facilitated HIV care in the correctional healthcare environment, and the experiences of other telehealth programs in the delivery of HIV related services to non-correctional patients. The authors wish to acknowledge the contributions and work of the 2002 HIV/AIDS Telemedicine Workgroup, Dr. Thomas Nesbitt et al, for sharing data collected as published in a previous monograph.<sup>1</sup>

#### II. Background

##### **A. Overview of HIV/AIDS:**

Human Immunodeficiency Virus (HIV) infection is an epidemic with a profound impact on global health. As of 2003, it was estimated that 40 million people have been infected with HIV and that more than 22 million people have died from the infection, including 3.1 million persons in 2002 alone.<sup>2,3</sup> Approximately 5 million new infections occur per year with the majority occurring in sub-Saharan Africa. In the United States it has been estimated that approximately 932,000 people are infected with HIV. Of these it is estimated that 40% (367,000) have been diagnosed and receive specific antiretroviral treatment; 5% have been diagnosed and are being treated, but are not receiving

specific antiretroviral treatment; 30% have been diagnosed, but are not receiving care; and 25% are estimated to be unaware of their infection. If these estimates by the CDC are accurate, more than 500,000 HIV infected persons in the U.S. have yet to receive care related to their infection. This epidemic has had a disproportionately larger impact on African-American and Hispanic patients with 61% of AIDS cases reported to the CDC in the U.S. occurring in these populations.<sup>4</sup>

While it was initially believed that all U.S. physicians could be expected to provide HIV care, it has become increasingly clear that clinical outcomes are directly related to the individual physician's knowledge and experience in treating infected patients. It is well known that certain regions of the country have relatively few highly experienced HIV clinicians. Such factors as the development of new classes of medications, the need for careful monitoring for complications of drug therapy, the development of drug resistance and the need for strict adherence to treatment protocols all support the concept of the delivery of AIDS care by AIDS specialists.<sup>5,6</sup> Some have drawn direct parallels regarding the care of HIV infected patients to the care of patients with cancer.

An additional barrier to care is the financial burden of chronic illness and the high cost of treatment. HIV/AIDS is disproportionately represented in people who are least able to pay for healthcare services. Federal or State funding sources are often required (Ryan White Care Act, Medicaid, Medicare, AIDS Drug Assistance Program or ADAP), but increasingly do not meet the growing need.<sup>7</sup> The gap between requested and appropriated funds to ADAP continues to increase, with the result that waiting lists for antiretroviral drug therapy continue to grow in several states.

## **B. Definitions**

- HIV - Human Immunodeficiency Virus.
- AIDS - Acquired Immune Deficiency Syndrome.
- CD4 Cell - Major target cell for HIV infection (T-lymphocyte).
- Viral load - blood tests that quantities HIV viral RNA copies and correlates with disease activity and therapy success.

- Resistance studies - HIV resistance to given drugs can be assessed by genotypic or phenotypic tests.
- ADAP - AIDS Drug Assistance Program – The AIDS Drug Assistance Program, funded through Title II of the Ryan White CARE Act, provides grants to States and Territories so as to provide medications for the treatment of HIV disease.

### **C. General data and trends in use of Telemedicine for HIV/AIDS care:**

The major use of telemedicine in the broader field of infectious diseases has been in the consultative and follow-up care of patients with HIV infection. Specific components of care of patients with HIV/AIDS include:

#### *1. Initial history and physical examination:*

A majority of telehealth programs responding to the 2002 Workgroup survey indicated that the initial assessment is best performed with an in-person comprehensive history, physical examination and discussion with the patient. This does not exclude the possibility of the primary care provider performing the initial assessment in consultation with the HIV specialist, however, most AIDS clinicians have indicated a preference for an initial history and physical examination.<sup>1</sup>

#### *2. Initial treatment and ongoing medical management:*

Initiation of drug therapy and follow up care which includes the regular assessment of laboratory data, can be facilitated and coordinated through the telehealth linkages. We and others have emphasized the need to obtain laboratory studies (CD4 count, viral load, blood chemistries and metabolic screens) prior to the visit, so as to maximize the interactivity related to the clinical decision making process at the time of the telehealth facilitated encounter.

#### *3. Specialty consultations:*

The long term side effects of treatment and greater life expectancy of patients with AIDS has demonstrated the need for access to specialists with expertise in AIDS related complications so as to manage co-morbidities. Specialists with expertise in AIDS dermatology, oncology, cardiology, neurology, psychiatry, infectious diseases

are often not available in rural communities, but may be accessed through telehealth networks.<sup>8,9,10</sup>

#### 4. End-stage AIDS and Palliative care

Although there are few published reports regarding the use of home monitoring and home telehealth applications in end-stage AIDS, such technologies offer opportunities to provide respite and/or home care. Monitors that facilitate transfer of such data as oxygen saturation, heart rate, weight, blood pressure, blood sugar can further facilitate care in the home. Such technologies may further enhance compliance with medication management. Becker reported a successful home care program in New York City<sup>11</sup>.

HIV infection is one of the most significant health care issues affecting our inmate populations.<sup>12,13,14,15</sup> Telehealth tools have increasingly been applied to the care of incarcerated HIV-infected persons, since most correctional systems already have designated health care professionals on site to help coordinate referral care and to enact specific recommendations. Specific blood or radiologic studies can be done in advance of the telemedicine consultation allowing the best advice to be given in an immediate, informed manner. Most importantly, routine chemistries and CD4 counts, HIV viral load, and HIV resistance studies in advance of the visit allow more rapid decisions regarding appropriate antiretroviral therapy than can usually be made in the standard outpatient setting. Directly observed administration of medications is an additional tool that enhances outcome in the correctional environment.<sup>16</sup> Additionally, these patients can be seen as often as necessary. Transportation needs are decreased and security issues are lessened.<sup>17</sup>

Preliminary data from the UVA experience has shown that care delivered via telehealth technologies in the prison setting has correlated with excellent therapeutic success. In a chart review of 126 incarcerated patients receiving telemedicine facilitated care, 77% of patients previously untreated with pharmacologic agents attained undetectable viral loads as did 59% of all patients, including those with previous antiretroviral experience and AIDS-defining illnesses.<sup>18</sup>

Greater logistical barriers exist for care in the non-incarcerated setting. In the non-correctional setting, rural HIV infected patients are more likely to receive care from clinicians with limited experience treating AIDS than urban patients. Using CDC data, Cohn et al reported that 6% of HIV infected patients reside in rural communities. Of that group, 38% of patients received care from clinicians who had treated fewer than 10 HIV infected patients in the previous six months. That figure contrasts with urban patients, of which only 3% had received care for similarly inexperienced clinicians.<sup>10</sup> Thus, telehealth facilitated services offer access to services otherwise unavailable to rural patients with HIV.

In most rural non-correctional settings, coordination with an on-site primary care provider to organize care and to implement recommendations has proven to be an effective adjunct to care provided by AIDS specialists. Coordination and payment for laboratory studies as obtained at the remote site in advance of the telehealth facilitated visit can be complicated when funding for care has been awarded to the specialty care site. Clustering of appointments with the AIDS specialist and associated AIDS subspecialty consultants is often necessary to maximize coordination of care all the while obviating the need for travel.

### **III. Step-by-Step Guide to Creating a Successful Program**

#### **A. General Telemedicine Programmatic Needs Assessment:**

Prior to the establishment of any specialty telehealth program, it is imperative to ascertain if such a program is aligned with the organization's mission and to identify potential stakeholders both internal and external to the institution. A clear-cut identification and assessment of the needs of the population to be served and the resources available to that population, both locally and using telemedicine technologies will help to ascertain the need for and potential value of such a program.

Consider developing a business plan and performing a cost-benefit analysis in an effort to identify all pros and cons, costs, reimbursements, cost savings and thus, the potential value of a telehealth program to the overall institutional mission. Although impossible to

entirely predict the potential revenue generated from the development of our telehealth program, (all the more so in a climate of relative non-reimbursement) it is imperative to identify regional and federal payers and the possible downstream effect of such an initiative (multiplier effect). In addition it is useful to identify federal, local and state grant agencies and corporations and foundations with an interest in rural and underserved populations. It is also important to identify and target key state agencies with a commitment (and budget) to support both healthcare and transportation of patients from underserved communities (e.g., Medicaid. Department of Corrections, etc.) with whom a contractual relationship could be developed.

## **B. Specific HIV Telehealth Programmatic Needs Assessment**

The provision of care of HIV infected patients has been shown to be most effective when provided in consultation with HIV specialists. Changes in drug protocols and monitoring for complications of drug therapy, drug resistance, and opportunistic infection requires a careful coordination of care both on the local level and at the specialty site.

Quality care provided to such infected individuals requires a rigorous attention to detail and is ideally suited to the use of telehealth technologies when HIV expertise and services are not locally available.

Clinical data sources to be used in needs assessment to guide the development of such a program may include such sources as:

### 1. State agency data:

- a) State data referencing medically underserved areas
- b) Department of Health data sources
- c) Department of Education datasets
- d) Department of Corrections datasets
- e) Department of Medical Assistance Services (Medicaid) datasets



## 2. Federal agency sources

- a) HRSA: <http://hab.hrsa.gov/reports/cdemo.htm>
- b) CDC: <http://www.cdc.gov/nchs/hus.htm>
- c) Census: <http://www.census.gov>
- d) Healthy People 2010/Healthy Communities database:  
<http://www.healthypeople.gov/document/>
- e) Bureau of Primary Health Care:  
<http://bhpr.hrsa.gov/healthworkforce/reports/profiles/>
- f) HIV/AIDS resources - <http://hab.hrsa.gov/aboutus.htm>

## 3. Institutional sources

- a) Strategic planning documents
- b) Existing affiliations (clinical and CME)
- c) Educational partnerships potentially facilitated by these linkages
- d) Focus groups with clinical departments

## **C. Goals, Objectives, and Processes of a Telemedicine facilitated HIV program**

The goals or objectives for a successful telemedicine program can be easily outlined and measured and include improved access to care and maximized individual care programs.

### 1. Program design based on needs and demands

Services offered may include primary care, consultative care and educational services. Telemedicine provides a unique venue for providing interactive HIV educational programs, offering health care providers regular updates regarding the latest advances in diagnosis and treatment and affords them real-time access to HIV experts in order to address immediate patient care problems. As noted, many HIV-infected persons, due to lack of resources or available expertise, do not have a primary care physician in their local setting, but HIV care can be conducted via telemedicine at a distance with some help and coordination at the local site

(e.g. Health Department or local hospital clinic). Finally, physicians already caring for HIV infected persons may require intermittent advice regarding a given patient but will continue to provide their ongoing primary care. Long distance travel can be avoided as such consultative advice can now be provided directly to the patient and physician via telemedicine.

Dealing with an otherwise litigious correctional population has not proven to be a barrier in any way. In the UVA program, all patients sign consent to participate in telehealth facilitated services as well as the UVA institutional patient privacy consent forms. They are also offered care via traditional transport models. No one has chosen traditional transport when telehealth facilitated care is available.

## **2. Factors to be considered when developing collaborations with external organizations:**

With potential protocols in mind and willing specialty providers engaged, consider approaching remote providers/organizations identified through needs assessment as having an interest in the provision of HIV/AIDS care to specific constituent audiences.

### **a) Correctional healthcare:**

As an organization with a large transportation and security budget, serving a litigious population and generally lacking in specialty care services, correctional healthcare programs are generally willing partners. Related to that, the following factors were identified in the needs assessment and planning processes:

#### **i. Security**

An issue of major concern to all correctional programs is the laborious and expensive process to ensure the provision of secure healthcare services outside the correctional healthcare environment. Outpatient visits are frequently scheduled months in advance of the outpatient encounter. On

the day of the consult the inmate (patient) often must be prepared for transport in the early hours, and placed for long periods of time in a segregation cell awaiting transport. Correctional programs generally assign two correctional officers for each inmate requiring transport to the hospital. If the facility has multiple patients requiring consults on the same day, the correctional facility frequently uses one van, staffed by 3-4 corrections officers supervising the inmates. Based on the appointment schedule and the duration of the consult at the hospital, the van, officers and inmates are often off-site for as long as 12 hours, increasing the security risk for all concerned.

ii. Cost savings to Departments of Corrections:

In Virginia, the cost of an inmate off-site medical consultation is estimated at \$300 - \$500 per visit, based on distance, duration of the trip and the overtime pay necessary to replace the officers who support the medical transport. It has been estimated that in the first 5 years since implementation of the UVA telemedicine collaboration, the Commonwealth of Virginia has saved \$1.2 million dollars in security costs, all the while providing improved healthcare services. However, healthcare costs have risen (consultations, laboratory testing and pharmaceutical agents) which placed additional pressure and strain on the correctional budget.

iii. Collaboration with Corrections:

- a. Identify clinical services to a number of correctional facilities (covered lives) as necessary, in a managed care model;
- b. Identify a mutually satisfactory technology solution;
- c. Establish mutually satisfactory clinical protocols of laboratory studies, data transfer, medication management, and scheduled follow up visits;
- d. Establish a scheduling process for elective and emergency consultations;

- e. Consider a management fee to support the network and maintain the equipment; and
- f. Decide about the integration of an electronic patient record.

#### **D. Outcomes**

Multiple positive outcomes have been realized by the use of care plans optimized and this has translated into improved outcomes. As discussed above, in a chart review of 126 incarcerated patients receiving care via telemedicine, 77% of patients naive to therapy attained undetectable viral loads as did 59% of all patients, including those with previous antiretroviral experience and AIDS-defining illnesses. With the success of telemedicine in HIV care, telemedicine referrals to the UVA Medical Center have increased for HIV and other patients in need of subspecialty expert care (e.g. Hepatology, Dermatology, Pulmonary, Neurology, Psychiatry, Infectious Diseases, Cardiology).

##### a. Non-correctional healthcare:

The process of coordinating HIV/AIDS care in the non-correctional population can be more challenging than serving incarcerated patients. Many of the rural and remote partner sites have little knowledge of the incidence of HIV infection in their region and no resources to provide such care. The challenge (and stigma) of access to contemporary protocols, otherwise relatively unaffordable drug regimens, follow up laboratory testing and treatment of opportunistic infections and other complications remains problematic even with access to HIV/AIDS specialists through telehealth technologies.

Partnerships with regional AIDS coalition groups, health departments and/ or community health centers offer unique opportunities to provide integrated models of healthcare delivery to HIV infected individuals when access to quality HIV care is not locally available.

**b. HIV/AIDS Education**

UVA has used the videoconferencing network to provide education to high school students in rural communities with high rates of teen pregnancy. Students have been very accepting of the use of such technologies for interactive educational offerings. Topics were identified in focus group discussions with the students and implemented with the blessing of school administration after content approval was obtained from the county school board.

In addition, the use of videoconferencing technologies for the training of health professionals through continuing health professional education venues is critical to the integration of primary care physicians, nurses and allied health workers into a seamless network of providers for the targeted patient populations. Patient education may also be provided through videoconferencing technologies.

**E. Implementation:****1. Technical Decision Making****a. Equipment:**

It is useful to visit other telehealth programs, review technical information available as provided by the Office for Advancement of Telehealth and vendor supported conferences such as the American Telemedicine Association.

Consider inviting vendors to demonstrate equipment for evaluation prior to procurement. Tools used in the clinical encounter may include:

- i. Room videoconferencing system
- ii. Patient exam camera
- iii. Oral camera
- iv. Electronic stethoscope (digital or analog) with send and receive units
- v. Document camera for patient imaging, lab studies, ECGs, radiographs
- vi. Digital camera
- vii. Teleradiology tools

b. Equipment Maintenance

Determine how on-going maintenance will be performed, by whom and the response time when equipment malfunctions occur.

c. Connectivity:

Technologies used in the care of patients with HIV infection are similar to those used in other specialties for which transmission of patient data and a clinical examination is critical. UVA has provided services using either H.320 or H.323 video protocols and bandwidths ranging from 384 kbps to full T-1, although lower bandwidth alternatives may be useful. Identify equipment used by other successful programs. Review the OAT Technical Guidelines for information on equipment and vendors.

d. Network management

Determine who will be responsible for network management, monitoring and repair. Identify the planned provider of network bridging capabilities and gateway management for purposes of multicasting and/or connections between centers using disparate telecommunications protocols.

## 2. Operational

a. Start up- The first 30 days:

1. Perform a site survey

- a. Identify the location of the communications closet;
- b. Identify the rooms for the encounters and other areas appropriate for connectivity such as a conference room;
- c. Discuss what changes need to be made to the room (paint, sound, lighting) and who will do the changes; and
- d. Meet with clinical and administrative staff to discuss the logistics of scheduling, billing, reimbursement consent and evaluation.

2. Universal Service Fund applications should be filed with the Rural Health Care Division of the Universal Service Administration Corporation.
- b. 31-60 Day Start up Window:
    1. Address logistical issues related to scheduling, billing etc;
    2. Order telecommunications services;
    3. Order all equipment; and
    4. Ensure that the remote site rooms are ready (wire, lighting, painting, furniture).
  - c. 61-90 Day Start Up Window:
    1. Install equipment;
    2. Configure network devices;
    3. Test all equipment and network connections;
    4. Schedule training sessions for technical, clinical and administrative staff at the remote site; and
    5. Practice mock encounters, exercising the entire process.
  - d. After 90 days
    1. Begin the patient encounter process based on the protocols established during the previous 90 days;
    2. Continue to refine the process, seek feedback from the providers, administrators and the patients; and
    3. Begin process of program evaluation.

#### **IV. LESSONS LEARNED FROM THE FIELD**

The UVA Telemedicine Network and others have demonstrated that primary and specialty healthcare services can be provided to incarcerated and non-incarcerated patients. Care plans in correctional healthcare need to take into account the unique features of this setting. Regimens need to be simple with the lowest side effect profile

possible, given that correctional program formularies may be constrained by restricted numbers of medications and that prisons offer limited access to comfort facilities inherent in the correctional environment. A major challenge in this setting is post-parole care. Guaranteeing a smooth transition to excellent community-based care requires significant planning and support.

In the non-correctional setting, timely periodic consultative care can provide support to individual providers willing to assume ongoing primary care support to HIV infected patients in a rural setting with regular follow up care by the AIDS specialty care provider and other specialty consultative providers.

In the UVA experience, access to HIV/AIDS care through telehealth linkages has also increased the pool of patients eligible for research protocols, although participation in such protocols requires immense logistical coordination and careful attention to data collection and reporting requirements.

Challenges remain, however, with financial barriers to the provision and coordination of care exacerbated by fiscal constraints, and disparate healthcare systems. Although these issues are relevant to all populations, the transient nature of some HIV infected individuals (especially those post release from prison) makes the delivery of coordinated care a significant challenge. Telehealth technologies however, offer an acceptable solution to the need for quality care of HIV infected individuals.

## **V. Protocols**

### ***A. Critical to the development of any institutional telehealth program is the development of general and specific protocols and processes that:***

1. Facilitate the encounter (scheduling processes);
2. Are timely for the patient;
3. Are convenient to the specialist physician (either in block scheduled or single encounter models);
4. Incorporate institutional patient registration protocols;



5. Integrate in a fashion to comply with institutional and payor billing requirements;
6. Meet all HIPAA and patient consent requirements;
7. Meet specialist requirements for medical information/laboratory studies provided prior to visit;
8. Ensure that the health professional serving as the patient presenter at the consult origination site is trained to use all technologies employed in the interaction; and
9. Facilitate communication with referring physicians.

### ***B. Assessment Policy***

Having patient records and laboratory results available in advance of the telehealth visit maximizes the benefit of the individual consult and allows rapid cost effective treatment decisions to be made. When feasible, an initial in-person clinical assessment of the patient is preferred, with follow up via videoconferencing. In the absence of complications, follow-up encounters with pre-visit laboratory testing on a q 4-month basis should be scheduled in the same manner as a traditional in-person clinic model.

### ***C. Specific protocols for the provision of HIV care as employed at UVA include the following:***

- a. Medical record reviewed by HIV specialty team prior to consultation;
- b. Current medications;
- c. Lab studies: CBC, platelets, differential, CD4 count, Viral load, Chemistry profile, RPR, Toxoplasma titer, CMV serology, Hepatitis profile including Hep A B, C serology, T cell subsets;
- d. Select circumstances require blood to be drawn for HIV resistance testing;
- e. Documentation of prior PPD testing and periodic assessment of lipid profiles;
- f. Chest radiograph;

- g. Vital signs and weight on day of consult;
- h. History; and
- i. Physical exam (stethoscope for heart and breath sounds, patient camera for skin lesions, oral camera for oral lesions as necessary).

## VI. References

---

1. Nesbitt, T, Siddiqui, J, Hilty, D., Brunader, R, Cole, S., Katz, J., Daschbach, M, and Chorba, K,  
[http://cht.ucdmc.ucdavis.edu/Publications/Telemedicine Outreach to Patients with HIV and AIDS.pdf](http://cht.ucdmc.ucdavis.edu/Publications/Telemedicine%20Outreach%20to%20Patients%20with%20HIV%20and%20AIDS.pdf)
2. <http://www.niaid.nih.gov/factsheets/aidsstat.htm>
3. <http://www.unaids.org/Unaid/EN/Resources/Publications/Corporate+publications/AIDS+epidemic+update+-+December+2003.asp>
4. <http://www.niaid.nih.gov/factsheets/Minor.htm>
5. Kitahata MM, Van Rompaey SE, Shields AW. Physician experience in the care of HIV-infected persons is associated with earlier adoption of new antiretroviral therapy. *J Acquir Immune Defic Syndr* 2000;24(2):106-114.
6. Stone VE, Mansourati FF, Poses RM, et al. Relation of physician specialty and HIV/AIDS experience to choice of guideline-recommended antiretroviral therapy. *J Gen Intern Med* 2001;16(6):360-368.
7. [http://www.aidsinfo.nih.gov/ed\\_resources/default.asp?REC\\_ID=30](http://www.aidsinfo.nih.gov/ed_resources/default.asp?REC_ID=30)
8. Mainous AG, 3rd, Matheny SC. Rural human immunodeficiency virus health service provision. Indications of rural-urban travel for care. *Arch Fam Med* 1996;5(8):469-73.
9. Forkner ME, Reardon TG, Carson GD. Experimenting with feasibility of telemedicine in Alaska: successes and lessons learned. *Telemed J* 1996;2(3):233-40.
10. Cohn SE, Berk ML, Berry SH, Duan N, Frankel MR, Klein JD, McKinney MM, Rastegar A, Smith S, Shapiro MF, Bozzette SA. The care of HIV-infected adults in rural areas of the United States. *J Acquir Immune Defic Syndr*. 2001;28:385-92
11. Becker C. High-tech treatment. Federal grant allows HIV/AIDS patients to receive treatment through telemedicine. *Mod Healthc* 2002;32(50):18-9.

- 
12. Crosland C, Pohkus M, Rich JD. Treating Prisoners with HIV/AIDS: the importance of early identification, effective treatment, and community follow-up. *AIDS Clin Care* 2002; 14:67-71
  13. Maruschak LM. HIV in Prisons, 2000. Bureau of Statistics Bulletin. US Department of Justice, Office of Justice Programs. 2002 Oct. NCJ 196023
  14. Harrison PM, Karberg JC. Prison and Jail Inmates at Mid-year 2002. Bureau of Justice Statistics Bulletin. US Department of Justice, Office of Justice Programs. 2003 Apr. NCJ 198877
  15. Spaulding A, et al. Human immunodeficiency virus in correctional facilities: a review. *Clin Infect Dis* 2002;35:1130-6
  16. Badubieri S, et al. Directly observed therapy to treat HIV infection in prisoners. *JAMA* 2000; 284:179
  17. McCue MJ, Mazmanian PE, Hampton C, Marks TK, Fisher E, Parpart F, Krick RS. The case of Powhatan Correctional Center/Virginia Department of Corrections and Virginia Commonwealth University/Medical College of Virginia. *Telemed J*. 1997;3:11-7.
  18. Wispelwey, B and Townsend, G, Unpublished data, University of Virginia 2003.

# Telehomecare

**Authors:** Susan L. Dimmick, PhD, University of Tennessee Telehealth Network  
Sam Burgiss, PhD, University of Tennessee Telehealth Network  
Mary Anders, RN, University of Tennessee Telehealth Network  
Lorraine Pellegrino RN, MHA, University of California – Davis

## I. Introduction

The purpose of this document is to provide a foundation for the development of a home Telehealth program for either home health agencies or for clinics that want to provide home telehealth monitoring for chronic disease management.

## II. Background

**A. Specialty Area** – Home telehealth currently is used in principally three ways: by traditional home health agencies, which have used the technology to leverage quality of care in a prospective payment environment; for the delivery of hospice services; and for case management by either hospitals or medical clinics to supervise chronically ill patients in their own homes. This primer focuses on developing a home telehealth program for home health agencies. Home telehealth is the use of synchronous or asynchronous telecommunication and computing technologies to deliver care between a health care provider and a patient in his or her place of residence. These technologies can be used to connect providers and patients in a real time for a typical type of medical encounter; or, the technologies can be used to deliver provider-directed monitoring or patient self-monitoring.

**B. General data and trends in use of TM in specialty area** – According to a 1998 **workshop** on future trends in medical device technologies sponsored by the National Science Foundation and the FDA, the primary need for today's

home-care population is more frequent and convenient monitoring of chronic diseases and conditions. A wide range of health and social services are gradually being delivered at home to recovering, disabled, chronically ill, or terminally ill people. William Herman, director of the division of physical sciences in the Food and Drug Administration's Center for Devices and Radiological Health (CDRH), which regulates medical devices, calls home-care systems "the fastest growing segment of the medical device industry." (FDA Consumer magazine May-June 2001, [http://www.fda.gov/fdac/features/2001/301\\_home.html](http://www.fda.gov/fdac/features/2001/301_home.html)).

Home care is one of the fastest growing sectors in the United States. In *Principles of Geriatric Medicine and Gerontology*, L.G. Pawlson states "for every nursing home resident, there are 3-4 patients with similar needs living at home. Home care usually follows an acute episode requiring hospitalization and can necessitate the monitoring of vital patient information for up to 60 days after discharge. Telehealth technology assists through frequent monitoring and close communication with elderly patients improving the quality of care delivered, reducing costs through fewer home nurse visits, potentially shortening the time required for home care and preventing hospital readmission, all significantly important in the current fixed-reimbursement environment of Medicare." (Pawlson, L.G. (1994). Health care implication of an aging population, In W.R. Hazzard, E.L. Bierman, J.P. Blass, W.H. Ettinger, and J.B. Halter (Eds.) *Principles of Geriatric Medicine and Gerontology*, New York, McGraw-Hill, pp. 167-176.)

### **C. Definitions specific to home telehealth:**

**(1) Interactive Home Telehealth** - Interactive Home Telehealth includes the use of two-way interactive audio video involving the patient and a health provider. This service provides for remote care delivery (i.e. assessment, education, data collection). Interactive Home Telehealth may also include devices for collecting clinical data from the patient and delivered to the health provider.

**(2) Plain Old Telephone Service (POTS)** – A standard analog telephone line.

**(3) Telemonitoring** -Telemonitoring includes the collection of clinical data and the transmission of such data between a patient in their residence and a health care provider through a remote interface so that the provider may conduct a clinical review of such data or provide a response relating to such data. This includes the use of automated laboratory or other health monitoring equipment, as well as the manual entry of data.

**(4) Self-Monitoring** - The periodic and scheduled use of a device by the patient to obtain clinical data that is used by the patient to measure their own health status. Commonly measured data include blood pressure, glucose, weight and temperature.

### **III. Step-by-Step Guide to Creating a Successful Program**

#### **A. Creating a home telehealth program**

The case for adoption of a home telehealth program for the traditional home health agency was made with the implementation of the prospective payment system (PPS) that became effective in October 2000. Under Medicare PPS, the new provision clarifies that there is nothing to preclude a home health agency from adopting telemedicine or other technologies that they believe promote efficiencies, but that these technologies will not be reimbursed by Medicare under the home health benefit. Medicaid reimbursement for home care using telehealth depends on the rules in each state. Some home care agencies have also been successful with obtaining reimbursement from commercial insurance.

For the home health agency considering the implementation of telehealth, a primary benefit is the potential cost-savings associated with the supplementation of regular in-home visits with home telehealth visits, potentially near \$50/visit. These cost-savings have been documented both in case studies (Dimmick et al, (2000), A Case Study of Benefits and Potential savings in rural home telemedicine, *Home Healthcare Nurse* 18(2): 124-135) and in studies where the findings were generalizable to health maintenance organization populations (Johnson et al, (1997)

Kaiser Permanente Medical Center's pilot tele-home health project. *Telemedicine Today*, 4(7): 16-1,19).

Other benefits include a reduction in unscheduled physician office visits; emergency room visits; fewer long-term care placements, and fewer hospitalizations. Over the five years that home telehealth has been used at the University of Tennessee Medical Center Home Care Services, providers, patients and caregivers consistently articulate the following benefits:

Overall providers perceive the following benefits:

1. Patients are more focused on the nurse during instruction;
2. Permits observation of caregiver performing treatments after on-site instruction;
3. Permits monitoring of blood pressure and other vital signs visually;
4. Permits monitoring of family caregiver's performance during wound care;
5. Can verify settings on in-home medical equipment;
6. Increases ability to manage and establish medication routines for patient;
7. Saves travel time and mileage reimbursement;
8. Increases nurse productivity;
9. Decreases the number of in-home nurse visits; and
10. Nurses can give immediate assessment when patient calls home health agency.

Overall patients perceive the following benefits:

1. Increased sense of security that medical help was readily available;
2. Increased and faster access to health care advice;
3. Home Touch <sup>TM</sup> system very easy to use;
4. Felt like they were in the same room as the nurse;
5. Reduced pain that had been exacerbated by travel to the doctor/clinic;
6. Reduces anxiety knowing that help is a videophone call away;
7. Saves transportation and travel time;
8. Reduces transportation problems;

9. Do not have to drive on dangerous roads, particularly at night and in winter;
10. Reduces confusion over medication use;
11. Save time during the teleconsult;
12. Increases sense of being in control;
13. Increases personal attention from nursing staff because they do not seem to be in a hurry to get to the next home visit;
14. Increases privacy; and
15. Quality of care is equal to or better than an in-home visit.

Overall caregivers perceive the following benefits:

1. Saves time in terms of transporting patient to doctor's office or clinic;
2. Reduces anxiety, knowing that health care support was available;
3. "Just-in-time" health care advice is available;
4. Adds value of being able to visualize a problem, such as a wound;
5. Reduces time to get medical help;
6. Is more convenient than an in-home health care visit;
7. Comprehensive, consistent care is available; and
8. Increases privacy.

The UT Telehealth Network (UTTN) helped the University of Tennessee Medical Center Home Care Services develop and deliver home telehealth beginning in 1998. UT Home Health has since conducted more than 1,300 home telehealth encounters. Based on that experience, and in working with Quality Home Care, a rural home health agency in Scott County, TN, UTTN has created a seven-step plan for the development of home telehealth programs. . These seven steps are for the planning process prior to implementing a project in home telehealth. Each step that will be implemented would be planned in advance. The seven steps are:

1. Evaluate needs;
2. Develop a care services plan;
3. Develop a business plan;



4. Plan technology;
5. Train personnel;
6. Test the care and technology plans; and
7. Evaluate processes and outcomes.

### **(1) Evaluate Needs**

One of the reasons for UT Home Health's success with telehealth lies in the strategy of determining which patients and disease conditions benefit most from teleconsultation and telemonitoring. Nurses developed the following clinical, operational and utilization indications:

#### **(a) Clinical Indications:**

- i) Chronic disease
  1. Congestive heart failure
  2. Chronic obstructive pulmonary disease
  3. Diabetes
  4. Cancer
- ii) Open Wounds
- iii) Parenteral/enteral therapies
- iv) Pain management

#### **(b) Operational Indications:**

- i) Patients not requiring "hands on" care by the nurse for each visit
- ii) Patients requiring two or more visits per week
- iii) Patients with an unreliable caregiver
- iv) Patients with a history of poor compliance to instructions, medications, or treatments
- v) Patients requiring follow-up observation of self/caregiver treatment performance
- vi) Patients with unexpected early discharge from the hospital
- vii) Hospice patients
- viii) Patients in rural location

**(c) Utilization Indications:**

- i) Patients requiring frequent clinic visits
- ii) Patients with frequent emergency room visits
- iii) Patients with frequent hospitalizations for exacerbation
- iv) Patients initiating frequent telephone contact with the home health office
- v) Homebound patients with a need for increased socialization

**(2) Develop a Care Services Plan**

A physician refers patients to home care. If the patient is determined to be eligible for home care and home telehealth, the physician's orders should specify the number of in-home skilled visits and the number of home telehealth skilled visits to be made per week for a 60-day episode. All initial evaluations, post-hospital evaluations and re-certification evaluations must be in-home skilled visits. Home telehealth visits are made as ordered by the physician in coordination with the patient and/or caregiver. Home telehealth visits are documented using Agency documentation guidelines and forms. Documentation of the home telehealth visit becomes part of the patient's medical record. One should research and understand how visits are scheduled and how they are conducted for in-person visits in an effort to mirror that process as closely as possible using telehealth.

A typical nursing consultation involves calling home care patients at a scheduled time once or twice per week, depending on the patient's condition and plan of care. Patients, nurse's aides and family caregivers are trained to use the system, which involves turning on power to the equipment and answering the telephone. Depending on the hearing capabilities of the patient, he or she either uses the speaker-phone or uses the phone receiver itself if the system provides that option. If interactive home telehealth is provided, the telemedicine nurse conducts a tele-consult appropriate to the plan of care. In this particular home health agency, a nurse was designated as the home Telehealth nurse. Both the nurse and the patient can see one another and the camera may be moveable so

that various aspects and views of the patient can be visualized. This data can also be collected by a central server (computer) and then accessed by the nurse. A home can have videoconferencing equipment, monitoring equipment, or both.

Additionally, patient homes can be equipped with monitoring equipment for blood sugar, pulse, blood pressure, EKG, temperature and weight. This data can be sent via plain old telephone service (POTS) to the home health agency's reception system, usually a desktop computer.

Interactive Home Telehealth affords the opportunity to provide health education incrementally and patients are much more focused on instruction (Dimmick et al, 2000). This probably happens because attention is more focused in the telehealth encounter, which becomes routine and shorter over time. A majority of patients indicate that the nurse who visited through home telehealth is "not in such a hurry." Patients attribute this to the fact that the nurse does not have to "rush off" to the next visit, which can be as close as 10 miles or less, or as far away as 50 or more in some rural settings.

Caregivers, in particular, seem to be empowered by having assistance "just a phone call away." They consider the telemedicine call to be different from an ordinary phone call to the home health agency. They say the difference is the ability to see and hear the nurse, and to have the nurse to see and hear them. Patient and caregivers indicate that they are more confident that medical problems are corrected quickly, because the nurse can see the situation instantly as opposed to hearing a verbal account of what is happening when only a regular telephone call is used.

Another aspect of care services planning involves continuous education, recruitment and enrollment of physicians to develop the home telehealth program. Physicians who know that patients can be discharged into well-monitored homes with a plan of care that includes a mix of traditional in-home and telehealth visits may be more likely to use this type of home health agency.

### (3) Develop a Business Plan

A typical centerpiece of a business plan is the return on investment (ROI). In the case of home telehealth, expenses are related to labor, operating costs, and equipment. Labor costs are fixed and determined by supply and demand. Labor costs can be reduced, because both nurse drive time and overall mileage reimbursement is lower. When a nurse uses telehealth instead of traveling to a home, the organization will save the cost of the labor and benefits of the nurse while traveling (e.g. driving) each way and the cost of the transportation (e.g. automobile) for the round trip. As previously described, this cost savings is approximately \$50 per trip (Dimmick et al., (2000), A Case Study of Benefits and Potential Savings in Rural Home Telemedicine, *Home Healthcare Nurse* 18(2): 124-135). These cost reductions may not be viewed as a savings in some home health agencies that choose to reallocate personnel to other service areas.

In addition to travel costs, nurse productivity is increased in home telehealth because more visits can be made per hour. The telehealth consult is 18 minutes on average compared to 45 minutes for the traditional in-home visit. Similar time savings were reported in a study of the Kaiser Permanente system. (Johnson et al (1997). If your organization is responsible for the total health cost of the patient, consider the reduction of cost for decreased hospital days, emergency department usage, decreased frequency of hospital readmissions in less than 30 days, or decreased medications.

Increased cost can consist of equipment for homes and nurse's stations, administrative personnel, personnel training, and technical support. Equipment selection should be made based on needs which may indicate video and/or monitoring equipment are the best investment for care delivery based on the patient. Also, consider that revenue can be increased because of increased patient census and increased services.

Equipment costs vary according to the technology used. Some companies offer a prepackaged integrated system that may include audio and video encounter

capabilities as well as remote monitoring devices (Figure 1). Other integrated systems have only the remote monitoring devices. Cost ranges from \$3,000 to \$7,000 per home. These systems may also be leased for approximately \$100 to \$200 per month. Many of these systems include text messages to the patient with patient selected responses. Systems that do not include this capability can cost less than that listed above.

Some programs use off-the-shelf technologies that can be put together and tailored to a particular home health agency's needs. Systems can be composed of components such as videophones, video monitors, and cameras. Videophones and additional components

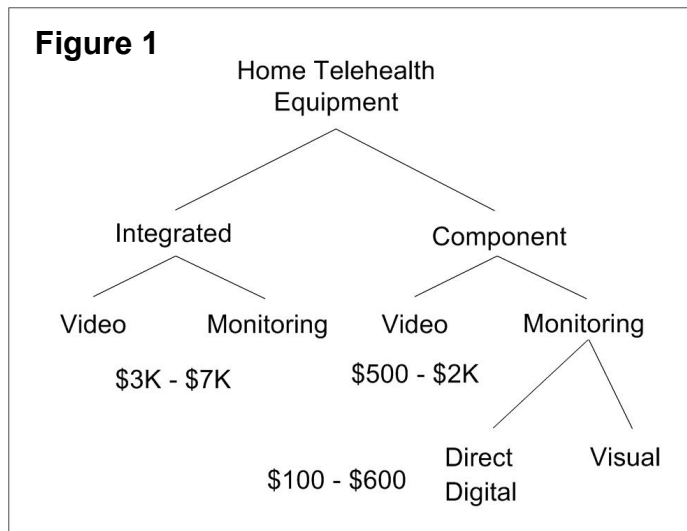

can range in price from \$500 to \$2,000. Component monitoring includes a single instrument monitor such as a glucometer with a modem to transmit digital data. Instruments commonly used in health care such as pulse oximeters, glucometers, sphygmomanometers, and weight scales can provide patient monitoring by nurse observation when videoconferencing is provided in the home. In addition to home systems, some nursing stations cost approximately \$10,000. A database server for monitoring may be available via the Internet for a per patient fee, which can range from \$20 to \$70 per month. Communication of patient information using the Internet requires HIPAA compliance.

If equipment in a patient's home is used twice weekly, and mileage and drive time costs are about \$50/visit, the time to return on investment can be calculated. For equipment cost in the home of \$1,000, 10 weeks under this scenario would pay for the equipment. Using another example of \$10,000 for equipment cost per home, approximately two years would be required to pay for

the equipment and to start a net cost saving. In the development of a business plan, consider the amortization of equipment over a three-year period to be conservative rather than a five year period that is often used.

#### **(4) Plan Technology**

When the home health agency develops a set of clinical, operational and utilization indicators, this helps to determine what communication capabilities are needed. For example, in the monitoring of congestive heart failure, some programs believe that both audio and video capabilities are needed, while others feel that only monitoring devices are required. Most often the following vital signs are a routine part of any traditional home health plan of care: blood pressure, pulse, oxygen saturation, weight, and in the case of diabetics, blood glucose. The disease state of the patients, the care to be provided by telehealth and the needs of the providers are critical to the decisions about the technology along with cost and return on investment.

Other types of care that can be delivered through home telehealth include:

1. Pacemaker surveillance
2. Intermittent EKG event recorders
3. Telephone strategies
4. Data transfer
5. Interactive video
6. Internet care

Other observations that may be needed, and that can be add-ons in terms of monitoring equipment, include:

1. heart sounds
2. chest sounds
3. skin and/or wound images
4. ENT scope

The next step is to determine what types of telecommunication connections are available in your patients' homes. Most often, particularly in rural areas, only POTS is available. This technology often is adequate for all of the vital sign monitoring and for heart and chest sounds, as well as skin and wound images.

If digital subscriber line (DSL) or cable modem technology is available, it may be an option for improved motion video. Consider the cost of the higher bandwidth service and the time required to install it before implementing this service. Communication of patient information on the Internet requires compliance to HIPAA regulations.

After the communications infrastructure availability is assessed, and after determining the transmission needs from the home, the agency should look toward these basic components for an equipment foundation, depending on the needed functions of video and/or monitoring:

1. A video camera for the provider to visualize the patient, wounds, medication, and monitoring instruments (if used)
2. A video monitor for the patient to visualize the provider
3. A speaker phone for audio communications
4. An interface to the communications line
5. Monitoring instruments to transmit physiological parameters

The following are commonly used monitoring peripherals:

1. glucometer
2. sphygmomanometer
3. pulse oximeter
4. spirometer
5. thermometer
6. weight scale
7. EKG leads

As discussed previously, these features can be obtained in an integrated system, a component system, or combinations of the two types. Features of the system are based on the needs of the patients, providers, and the organizations providing the care.

#### **(5) Train Personnel**

Home telehealth training should occur in three separate categories: patient care, use of equipment, and infection control. The best way to train staff is to develop a "Telehealth Skills Checklist". An example of this type of checklist can be found in Section VI, Sample Clinical Protocols.

- a) For patient care, the critical elements of provider training should cover the following:
  - i) Review of the telehealth policies and procedures with patient AND caregiver (if a caregiver is available in the home);
  - ii) Review of the home telehealth patient instructions;
  - iii) Provide the patient AND caregiver with teaching material pertinent to telehealth;
  - iv) Schedule the consults with other health professionals through telehealth as appropriate;
  - v) Obtain the patient/caregiver's permission and signatures on consent form and on the telehealth equipment agreement form;
  - vi) Conduct a telehealth visit that assesses the patient;
  - vii) Complete the visit documentation and complete patient satisfaction survey for each tele-visit; and
  - viii) Assist other health professionals with telehealth visits so they properly prepare the patient for the tele-visit; appropriately present the patient (including a patient introduction); properly provide a verbal description of the problem, provide nursing observations of the presenting problem; operate telehealth equipment as necessary; assist with changes in treatment plans; and schedule follow-up visits, as required.



- b) For equipment care, the critical elements for training include:
  - i) Correctly identify telehealth equipment components and assemble equipment elements appropriately;
  - ii) Correctly demonstrate the use of all equipment, including connection to another nursing site;
  - iii) Demonstrate use of any monitoring equipment including messaging with nurse if provided; and
  - iv) Demonstrate the correct use of the telephone keypad to access menus or other controls in the system for view, size, quality and camera (if these are included):
    - 1. Demonstrate the correct use of the camera menu to pan, zoom, tilt and use the snapshot option (if these are included) and demonstrate activation of the privacy option (if this option is included); and
    - 2. Demonstrate the ability to adequately visualize both the patient and objects that the patient may be using as biometric peripherals as appropriate to the system configuration.
  
- c) For infection control, the critical elements for training include:
  - i) Reviewing the established policies and procedures for the cleaning and disinfecting the telehealth equipment;
  - ii) Identifying when equipment must be cleaned;
  - iii) Identifying the type of disinfectant(s) to be used; and
  - iv) Identifying the type of disinfectant(s) that should never be used.

## **(6) Test Care and Technology Plans**

It is important to start with a small set of patients when beginning a home telehealth program. It is equally important to start with a small set of nurses to deliver telehealth care. Although anecdotal, it appears that home health agencies that designate a specific nurse to be the home telehealth nurse coordinator are more successful in fully deploying telehealth. This does not

mean that other nurses do not use the telehealth system. It means at the outset of a telehealth program, it is important to have a “go to” nurse who has developed expertise in using telehealth and who can help troubleshoot problems and brainstorm new ways to use the system.

After training a telehealth nurse coordinator for the agency, this coordinator trains other nurses and allied providers in the use of the system. Training for the nurse coordinator would be provided by published documents as shown in the Useful References section and by successful home telehealth programs that offer education for other home care agencies and health facilities. The first assessment that must be done is to determine the suitability of the home for telehealth management. Some considerations include the stability of the phone system and ability to pay for phone services. Many rural residents, for example, because of poverty, have varying phone service dependent on their ability to pay monthly. A second major consideration is adequate lighting within the home for programs using interactive home telehealth. A third consideration is the security of the home so that equipment can be recovered at the end of the home telehealth episode. Patients must also sign and fully understand the patient consent form for use in home telehealth. [An example of a consent form is provided in Section VI, Sample Clinical Protocols.]

The next step involves the actual training in the use of the equipment. Familiarity with the equipment usually is achieved within a week’s time. Expertise with using telehealth to monitor and manage patients in the home usually is developed within three to six months. If videoconferencing is used, some of the video equipment variables that must be attended to include adjustment for lighting; camera movement and panning; still image capture, and reduction of excessive motion for equipment using the POTS.

After the nurse is trained, instruction should follow in how to educate patients in the use of the equipment. Patient training in the use of the equipment is done in the home. Additionally, patient care of the equipment also must be reviewed. A

checklist addressing this is included in the Section VI, Sample Clinical Protocols. Some of the summary points in educating patients in the care of the equipment include protecting the equipment from direct sunlight; protecting it from food and water spills; keeping equipment out of the reach of children and animals; and prohibiting the use of common household cleaners on the equipment.

Additional points of training include the necessity of communicating with physicians during the course of care, and in properly documenting care, both in terms of the usual and customary home care data but also documenting the reliability and performance of the home telehealth equipment in enabling home care. An evaluation tool for evaluating equipment performance is included in the Section VI, Sample Clinical Protocols.

Some specific lessons learned from the University of California at Davis' telehospice program in terms of things to consider:

1. Identify your goals, i.e., ease the dying process in home;
2. Emphasis on symptom management through the final stages of life; and
3. Focus on supportive care to patient and family.

Some of the possible challenges include the fact that not all families and patients may accept telehospice readily. The introduction of a new concept (telecare) at a time when patients and caregivers are already stressed may cause problems. Families or patients may also perceive that the introduction of the technology may result in diminished visits by the hospice nurses.

## **(7) Evaluate Outcomes**

Evaluation of the home telehealth occurs at two levels: process evaluation and outcome evaluation. Process evaluation involves counting the number of visits; the type of visits; the length of the visit; and what data were transferred from patient to agency.

Outcome evaluation involves determining whether delivering a mix of home telehealth and traditional agency home care had an impact on: the clinical condition of the patient; the productivity of nursing staff; the costs of delivering care; and patient and provider satisfaction, for example.

As a matter of process evaluation, the following data should be collected:

1. Date and duration of home telehealth visit;
2. Reason for telehealth visit – routine plan of care or unscheduled visit;
3. Operability of telemedicine equipment;
4. Assessment of adequacy of telemedicine equipment to assess patient's condition; and
5. Assessment of whether the visit would have been made if telehealth were not available.

Data that are routinely collected for outcome evaluation in academic medical settings include:

1. Patient demographics, including ethnic heritage, gender, education level, household income, employment, insurance coverage, distance from home health agency;
2. Provider demographics such as gender, number of telehealth referrals, number of telehealth consults, formal training in telehealth delivery; main reasons for using telehealth, specialty, primary practice setting, years in practice setting, and type of employment within health system;
3. Critical outcome measures for specific disease conditions; for example, for diabetics, hemoglobin A1C measured every three months from entry into program to follow up after discharge (decisions about which critical outcome measure should be made in conjunction with prevailing professional norms about what constitutes a clinical improvement for a specific disease condition);

4. Nurse travel time and mileage are tracked to determine potential cost savings of home telehealth visits;
5. Nurse visit time during telehealth consults are tracked to determine longitudinal productivity gains or potential losses in productivity;
6. Provider satisfaction; and
7. Patient satisfaction. For a validated and reliable instrument for the measurement of perceptions of telemedicine in home health see Demeris G, Speedie SM., Finkelstein S, 2000.

Define how you will measure and track results. This determination should consider the audiences for cost justifications, including agency administration; hospital administration in the case of the home health agency that is a part of that organization hierarchy; federal and other grantors in the case of home telehealth programs that are fully or partially supported by grant funds; organizations that monitor the quality of care delivered in the home, such as CMS, JCAHO, state Medicaid programs, and state licensure boards.

#### **B. Planning the Program for Underserved Areas**

Home health agencies are more in demand in rural areas because of the difficulties patients have in accessing doctors, and it also is difficult for home health providers to get to patient homes. Generally, there are fewer “local” home health agencies in rural areas. The trend is toward large urban medical centers to provide outreach through home health to remote areas. Extending home health into remote areas involves long distances and drive times for providers.

Generally, the remote area population is rural, low income and either uninsured or underinsured. Rural economies struggle under the weight of poorly developed public sector infrastructure, including under-funded schools, public health facilities, an aging population and a stagnant tax base. The payor mix weighs heavily toward the uninsured, underinsured and Medicare patients. When there are hospitals available in rural areas, they often are the largest employers, but in many rural counties, there is an inadequate supply of quality medical clinics, specialists, mental health

providers and too often, even primary care providers. Referral patterns generally are ingrained and gravitate toward a specialist or two in the nearest town geographically.

Potential partners include those that operate durable medical equipment businesses; home monitoring suppliers; physician offices; local hospitals; and contractors for services related to physical therapy, occupational therapy and speech therapy. Hold meetings to discuss telehealth with the potential partners within the remote community. This may include: Meeting with the rural home health agency if one exists. Give the agency a general overview of telehealth and how it works to meet patient needs in home health. If an urban-oriented home health agency has plans for expansion into rural areas, meetings with physician groups and hospital administrators are pertinent. Generally speaking, “due diligence” meetings with health care providers would be conducted to assure the community that home telehealth is an excellent tool for keeping people in their own homes and in their own communities for as long as is feasible.

It is important to obtain verbal buy-in from area physicians and hospital administrators. Cost estimates for the appropriate home telehealth telecommunications equipment that will fit the needs of a particular home health agency and its patients needs to be defined. Under the PPS requirements, the “revenue stream” for home telehealth generally is in terms of cost savings from mileage and drive time saved. However, work on contracts or memorandums of agreement between equipment vendors or home telehealth consultants need to be developed so that all network partners understand the costs and responsibilities that each party will assume. Identify who needs to be involved both internally and externally in this agreement. Also identify who will be responsible for collecting evaluation data.

### **C. Technical Analysis**

One should identify equipment used by other successful programs as well as review the TDRT web site (<http://tdrt.aticorp.org/>) and OAT Technical Guidelines (<http://telehealth.hrsa.gov/pubs/tech/home.htm>) for assessments of equipment and

for information about vendors. Determine how on-going maintenance will be provided. This includes a decision as to whether to buy spare equipment or to buy extended service contracts (24/7). Determine remote network connectivity. In the case of home telehealth, the connectivity is generally POTS, so most dealings will be with the local telephone company.

A few home telehealth equipment suppliers offer ISDN or IP capabilities, so purchase of this type of equipment requires a good understanding of network capacity in the individual counties in which the home health agency operates.

Determine who will be responsible for equipment management. Technical staff must understand home variations (lighting, sound, camera/equipment placement, and privacy considerations) for optimal telehealth consultations.

Prior to the operational phase, planning following the seven steps shown above should be done. After planning is completed, the operational phase shown below would begin.

#### **D. Operational**

##### Start-up – The First 30 days

1. Order equipment.
2. Initial meetings with the home health agency: Agency staff should determine the location of the home telehealth nursing station unit.
3. Administrative, technical and clinical staff should determine that the nursing station unit in the consulting room can be adequately wired.
4. Technical staff should determine the general layout of the room and what changes (lighting, sound, wall color), if any, need to be made. The agreement should specify which party is responsible for any room modifications.
5. Administrative and clinical staff should meet to discuss the logistics of scheduling, billing, reimbursement, evaluation, consent, and other administrative issues related to the program.

### The 31 to 60 Day Start-up Window

1. Administration should continue to work on all of the logistical issues related to scheduling, billing, etc.
2. Nurse's station room remodeling, if needed, should begin around day 31, to be completed by the 60th day.
3. Develop policies, procedures and protocols.
4. Develop consent forms and tele-visit forms.
5. Develop evaluation tools to pilot in the next step.

### The 61 to 90 Day Start-up Window

1. Nurse's station equipment installed.
2. Home equipment placed and patient instruction begins.
3. Training of home health provider personnel.
4. Administrators finalize the logistics of scheduling, billing, etc..
5. Mock cases are conducted to determine the smoothness of the process and to make refinements as necessary.

### The 91st Day

1. The telehealth program begins to care for patients based on the groundwork laid during the first 90 days.
2. Refinements and adjustments to the program can be made at this point.
3. Evaluation data begins to be collected.

## **IV. Lessons Learned from the Field**

### **TeleWatch System from Johns Hopkins**

TeleWatch is a telephone-based, automated telemedicine system that allows health care providers to monitor physiologic parameters and symptoms of outpatients in their homes. The system is also easily adapted to monitor the efficacy of treatment, provide real-time feedback, educate patients and disseminate information to individual patients or large cohorts. Because no specialized monitoring equipment is required for patients



to use the system, it is easy to deploy, simple to use and very cost effective. It does require that the patient provides physiological data by self-report.

Because patients interact with the Johns Hopkins TeleWatch System using a telephone, no other telecommunications equipment is required within their home. Additionally, since individuals may access the system from any telephone, their mobility is markedly enhanced without degrading the level of monitoring. Since greater than 95% of the population has access to and knows how to use a telephone, a telephone-based approach ensures widespread accessibility to the TeleWatch system. It also makes the system simple to use and easy to deploy.

As of August 2002, approximately 140 patients were using TeleWatch at Johns Hopkins and an additional 50 patients in the heart failure program. Patient utilization rates are very high with an average of 65% of heart failure patients and 54% of diabetic patients using the system on a daily basis. Over 70% of all patients access the system at least three times a week. In addition to patients displaying their satisfaction with the system by calling in regularly, they have also provided written feedback.

Physicians have also been pleased with the system as evidenced from this letter from a Cardiologist:

“I recently had a fax of his latest BP and weight as well as his laboratory results which proved to be extremely helpful in his medical management...I think this TeleWatch is an excellent one and has already improved my ability to treat [the patient].”

### **UC Davis Health System: Center for Health & Technology**

#### **Televisits in Home Health -- Deployment in Rural Areas**

The Center for Health and Technology at the University of California, Davis Health System received Federal funding from the Office for the Advancement of Telehealth in September 2000. A major focus of the grant is the development of home health linkages to patient homes in Colusa, Susanville, Portola and Fall River Mills California.

A valuable piece of information that came from the first site visit was the request to be able to speak with other home care agencies that have used this technology. To address this need, a multi-site videoconference was put together with guest speakers from the east, northeast, southeast and west to provide an overview of their program and experiences deploying this type of technology in the home care setting. Quarterly video meetings have been and are being held to provide a forum of discussion on what is working and challenges faced.

### **University of Tennessee Telehealth Network, Knoxville, TN**

Rural patients were initially reluctant to accept home telehealth when the equipment agreement stipulated that they had some liability for equipment damage. When that clause was removed from the agreement, more patients were willing to participate in home telehealth.

Lighting in the home is the biggest technical challenge home health agencies may face. Don't be afraid to suggest a rearrangement or supplementation of lighting sources within the home.

The biggest sticking point in patient acceptance of home telehealth continues to be having a camera in the home for audio-video applications. Patients must be shown and reminded that the camera lens can be covered, and that they in fact control the camera view by selecting a consistent place within the home where the televisit is conducted and that this view is quite limited.

Diffusion of home telehealth in a home health agency appears to be more rapid when a particular nurse or staff member is designated as the "go to" person for making home telehealth happen in the Agency. This individual becomes the expert and as the technology diffuses to all providers within the agency, there is still a single source of knowledge and encouragement when technical problems develop.

One of the most important lessons learned is that initial marketing efforts must be repeated at three-month intervals to remind providers that home telehealth visits are

available. Additionally, a marketing effort directed at patients to make them aware that home telehealth is available in their area can be an effective strategy.

## **V. Useful References (websites and documents)**

### **VENDORS**

Aerotel.

<http://www.aerotel.com/telemed/index.html>

American Medical Alert Corp.

<http://www.amacalert.com>

American TeleCare

<http://www.americantelecare.com>

AMD Telemedicine

<http://www.amdtelemedicine.com>

Cybernet Medical

<http://www.cybernetmedical.com>

Health Hero Network

<http://www.healthhero.com>

HomMed

<http://www.hommed.com>

Viterion TeleHealthcare

<http://www.viterion.com>

For an extensive list of vendors, please visit

<http://tie.telemed.org/homehealth/vendors2000.asp>

### **ACADEMIC CENTERS**

[A Distributed Telemedicine Network for Eastern North Carolina](#)  
Greenville, NC

[University of Tennessee Telehealth Network, Knoxville, TN](#)

[Caregiver College Physical Medicine and Rehabilitation](#)  
Detroit, MI

CareMed Chicago

<http://www.caremedchicago.com/WHATSNEW.htm>

Carle Foundation Hospital

<http://www.carle.com/cfh/centers/telemedicine2.htm>

Medical College of Georgia, Telemedicine Center

[www.mcg.edu/telemedicine/index.html](http://www.mcg.edu/telemedicine/index.html)

University of Kansas Medical Center

<http://www.kumc.edu>

University of Iowa, Telemedicine

[www.lib.uiowa.edu/hw/telemed](http://www.lib.uiowa.edu/hw/telemed)

University of Texas Medical Branch at Galveston

<http://www.utmb.edu>

### **HOME HEALTH AGENCIES**

[Kansas Care, Inc.](#)

Salina, KS

Maine Telemedicine Services

[Metropolitan Jewish Health System Telemedicine Project](#)

Brooklyn, NY

[Telehomecare Project](#)

Philadelphia, PA

### **NURSING AGENCIES**

Methodist Visiting Nurse Association of Houston (VNA)

<http://www.methodisthealth.com/vna/>

[VNA Telehome Care Program](#)

Sonora, CA

**OTHER**

2003 Federal Telemedicine Update-federal agencies and activities (must be purchased)

<http://www.federaltelemedicine.com/contents.htm>

2003 Federal Telemedicine Update-university and state activities (must be purchased)

<http://www.federaltelemedicine.com/university.htm>

American Telemedicine Association

[www.atmeda.org/news/list.html](http://www.atmeda.org/news/list.html)

Association of Telehealth Service Providers

[www.atsp.org](http://www.atsp.org)

Center for Telemedicine Law

[www.ctl.org](http://www.ctl.org)

Detroit Home-based Primary Care Telemedicine Demonstration Project

<http://www.hsrp.ann-arbor.med.va.gov/detroit.htm>

Federal Telemedicine Directory

<http://telehealth.hrsa.gov/jwgt/teldirect98/index.html>

Federal Telemedicine Update. Online magazine

[www.cbloch.com/index.htm](http://www.cbloch.com/index.htm)

Montana Healthcare Telecommunications Alliance

<http://ahcc.msu.montana.edu/mhta/default.html>

Office for the Advancement of Telehealth (Dept. of Health and Human Services)

<http://telehealth.hrsa.gov/>

Telemedicine & Advanced Technology Research Center. (Dept. of Defense)

<http://www.tatrc.org/>

Telemedicine Information Exchange *Home Health and Telemedicine*

<http://tie.telemed.org/homehealth>

*Telemedicine Journal*. See American Telemedicine Association.

<http://www.americantelemed.org>

**Documents**

Agrell, H., Dahlberg, S., & Jerant, A. F. (2000). Patients' perceptions regarding home telecare. *Telemedicine Journal and E-Health*, 6, 409-415.

- Allen, A., Doolittle, G. C., Boysen, C. D., Komoroski, K., Wolf, M., Collins, B., & Patterson, J. D. (1999). An analysis of the suitability of home health visits for telemedicine. *Journal of Telemedicine and Telecare*, 5, 90-96.
- Allen, A., Roman, J., Cox, R., & Cardwell, B. (1996). Home health visits using a cable television network: User satisfaction. *Journal of Telemedicine and Telecare*, 2(Suppl), 92-94.
- Burgiss, S.G. & Dimmick, S.L. (2002). "Telehealth in Home Health Care" in Armstrong, M.L. and Frueh, S. (Eds.) *Telecommunications for Nurses: Providing Successful Distance Education & Telehealth* (2<sup>nd</sup> Edition). New York: Springer Publishing Co.
- Demeris G, Speedie SM., Finkelstein S, (2000). An Instrument to measure patient's perceptions of Telemedicine's risks and benefits in home care, *Journal of Telemedicine and Telecare* 6(5):278-284.
- Demiris G, Speedie S, Finkelstein SM. 2000. Measuring patients' perceptions of telemedicine's role in home care. *Telemedicine Journal*, 6:176.
- Dimmick, S.L., Burgiss, S.G., Robbins, S., Anders, M., Black, D. & Jarnagin, B. (2003). "Outcomes of an Integrated Telehealth Network Demonstration Project". *Telemedicine Journal and e-Health* ([www.liebertpub.com](http://www.liebertpub.com))
- Dimmick, S.L. & Burgiss, S.G. (2002). "Marketing Telehealth Programs" in Armstrong, M.L. and Frueh, S. (Eds.) *Telecommunications for Nurses: Providing Successful Distance Education & Telehealth* (2<sup>nd</sup> Edition). New York: Springer Publishing Co.
- Dimmick, SL, Mustaleski, C, Burgiss, SG. (2000). A Case Study of Benefits and Potential savings in rural home telemedicine, *Home Healthcare Nurse* 18(2): 124-135.
- Doolittle GC, Whitten P, Clemans C, and Cook D (Spring 1999) Patient, caregiver, and provider perceptions of a tele-hospice service. [abstract]. *Telemedicine Journal* 5(1) : 55.
- Doolittle GC, Whitten P, Clemans C, and Cook D (Spring 1999) Patient, caregiver, and provider perceptions of a tele-hospice service. [abstract]. *Telemedicine Journal* 5(1) : 55.
- Fishman, D. J. (1997). Telemedicine: Bringing the specialist to the patient. *Nursing Management*, 28(7), 30-32.
- Johnson et al, (1997) Kaiser Permanente Medical Center's pilot tele-home health project. *Telemedicine Today*, 4(7): 16-1,19
- Rau, K. (2000). Expanding the NP's role through telemedicine. *The Nurse Practitioner*, 25(4), 105-108.

Valero, M. A., Arredondo, M. T., del Nogal, F., Rodriguez, J. M., & Frias, E. (2000). Patient satisfaction with a home televisiting service based on interactive television over a cable network. *Journal of Telemedicine and Telecare*, 6(Suppl 1), S99-101.

Visco, D. C., Shalley, T., Wren, S. J., Flynn, J. P., Brem, H., Kerstein, M. D., & Fitzpatrick, J. J. (2001). Use of telehealth for chronic wound care: A case study. *Journal of Wound, Ostomy and Continence Nursing*, 28(2), 89-95.

Warner, I. (1998). Telemedicine in home health care: The current status of practice. *Home Health Care Management and Practice*, 10(2), 62-68.

Whitten P, Collins B, and Mair F (1998) Nurse and patient reactions to a developmental home telecare system. *Journal of Telemedicine and Telecare* 4(3) : 152-60.

Whitten P, and Collins B (1998) Nurse reactions to a prototype home telemedicine system. *Journal of Telemedicine and Telecare* 4(Suppl 1) : S1:50-2.

Whitten P, Cook DJ, and Doolittle G (Sep/Oct 1998) An analysis of provider perceptions for telehospice. *American Journal of Hospice and Palliative Care* 15(5): 267-74.

## **VI. Sample Clinical Protocols (next page)**

---

**UNIVERSITY OF TENNESSEE MEDICAL CENTER**  
**TELEHEALTH NETWORK**

**POLICY:** 300.25

**TITLE:** Agency Home Care

**DEvised:** 3/02

**REVIEWED:** 3/04

**REVISED:**

**APPROVED TELEHEALTH COMMITTEE:** 3/04

**PURPOSE:** To provide guidelines for use of Telehealth in Agency Home Care (Telehomecare). The needs of the patient and family are the primary consideration, along with healthcare regulations, when evaluating and establishing a patient for telehomecare visits in an agency home care setting.

**Appropriate Patient:**

Any patient referred to Home Care by a physician that meets all regulatory guidelines and Patient Selection Criteria for Telehealth. (See ‘Patient Selection Criteria’ Form.)

**Procedure:**

A. Prior to Telehomecare visit

1. Physician refers patient to Home Care with possible use of Telehomecare.
2. Home Care nurse does an initial evaluation and assesses the patient and home for admission to the home care agency and for Telehomecare. (See Patient Selection Criteria for Home Care Telehealth)
3. Consent Form: If the patient is determined to be eligible for home care and telehomecare, a Telehealth Consent Form, in addition to the agency’s consent form, is signed by the patient or guardian.
4. Physician’s orders: If the patient is determined to be eligible for home care and telehomecare, the physician’s orders must specify the number of in-home skilled visits and the number of Telehealth skilled visits to be made per week for a 60 day episode. All initial evaluations, Post-Hospital Evaluations (PHE) and recertification evaluations must be in-home skilled visits.
5. The Home Care Staff furnishes, sets up and trains the patient and/or caregiver in the use of the Telehealth equipment. (See “Patient Instructions” Form)
6. The Home Care representative explains the Telehealth Equipment Agreement Form to the patient or caregiver and has them sign that they understand and agree. (See Telehealth Equipment Agreement Form.)
7. Telehomecare visits are made as ordered by the physician in coordination with the patient and/or caregiver.



8. Telehomecare visits should be documented using Agency documentation guidelines and forms. Documentation of Telehomecare visits is to become part of the patient's Medical Record.

**B. Day of Telehomecare skilled visit:**

1. The nurse calls the patient at the predetermined time agreed upon by the agency and the patient and/or caregiver.
2. When the patient or caregiver answers the phone the nurse and patient/caregiver can talk but can not see each other. When both parties are ready to start the video, the nurse will press the # key to display the Start Video menu.
3. The nurse will press the 1 key to start the video call. Establishing the video call normally takes 15 to 45 seconds. During this time, you will not be able to speak with the other party.
4. When the image of the other party is on your television screen, your video call has begun. You can speak through the telephone handset or place the phone on "speaker". Adjust the volume on the TV speakers as necessary.
5. Complete assessment, teaching, and training, etc. as outlined in the patient's Plan of Care and document in the patient's Medical Record.
6. Simply hang up the phone to end the video visit.

## Home Care Telemedicine

### Patient Instructions

#### What is Telemedicine/Telehomecare?

In very simple terms, this means that through the use of a television, camera and telephone you can communicate with the Home Care Staff.

#### How does it work?

Someone from Home Care will bring the equipment needed to your home. The equipment will be set up in a location decided on by you and the home care representative.

At the time of the “telehomecare visit” the nurse will call you on the phone. The time of the “visit” will be predetermined and agreed upon by you and the nurse. You will be able to talk with your nurse, but she/he will NOT be able to see you until you or your caregiver turn on your television and camera and the system is activated.

When you are ready, you or your caregiver will turn on your television monitor and your ViaTV camera. When the television and camera are turned on, the screen on the television should display the view from the camera. Adjust the camera’s view as necessary. It is best to do this BEFORE the nurse calls you. When your nurse calls, lift the handset to answer the phone. You will be able to see the view from your camera on your television screen. You will not see the nurse nor will the nurse see you until the nurse activate the system.

The nurse will activate the system by pressing the # key to display the Start Video menu. She/he will then press the 1 key to start the video call. Establishing the video call normally takes 15-45 seconds. During this time, you will NOT be able to speak with your nurse. When you see an image of the nurse, your video call has begun. You can speak through the telephone handset and hear the nurse through both the handset and television speakers. The nurse will be able to see the view from your camera.

You can end a video call at any time simply by hanging up the phone.

#### How do I initiate a call to my nurse?

- Turn on your television monitor.
- Turn on your ViaTV camera.
- Pick up the telephone receiver.

If you have call waiting you will need to disable it. To disable call waiting with touch-tone service, press the \* key followed by the 7 key and 0 key. To disable call waiting without touch-tone service, dial 1170. Call waiting will be restored when you hang up.

- Call \_\_\_\_\_
- Ask for the Telemedicine nurse.
- The Telemedicine nurse will activate the video system from her telephone.
- Hang up at completion of call.

## Home Care Telemedicine

### Patient Selection Criteria

The following selection criteria will be considered in patient selection for Home Care Telemedicine. (Telehomecare)

**Clinical Indications include, but are not limited to the following:**

1. Chronic disease
  - a. CHF
  - b. COPD
  - c. Diabetes
  - d. Cancer
2. Open wounds
3. Parenteral/enteral therapies
4. Hospice
5. Speech Therapy
6. Physical Therapy
7. Occupational Therapy

**Patient Criteria:** (Must meet all \* criteria. Should meet one or more of the non \* criteria)

1. \* Does not require “hands-on” care by the nurse with each visit.
2. \* Patient and/or caregiver have hearing adequate to communicate via telephone.
3. \* Patient and/or caregiver receptive to Telehomecare.
4. \* Patient and/or caregiver physically able to activate equipment
5. \* Patient able to tolerate 10-20 minute encounters.
6. \* Patient and/or caregiver able to follow simple directions.
7. Patient has a history of poor compliance to instructions, medications, or treatments. (This may be evident through frequent ER visits and/or frequent hospitalizations for exacerbation of disease)
8. Patient requires follow-up observation and assessment of wound status.
9. Patient and/or caregiver require follow-up observation of treatment performance.
10. Patient requires teaching and support with their disease process.
11. Patient and/or caregiver can perform tasks, but are not independent with performance or reporting.

**Environmental Criteria:** (Must meet all)

1. \* Plug-in telephone receptacles
2. \* Touch tone telephone available
3. \* Room location with privacy and adequate lighting
4. \* Convenient and safe three prong electric outlets

## TELEMEDICINE EQUIPMENT AGREEMENT

I have received the equipment described below in good condition from \_\_\_\_\_  
Home Care Agency to be used on a loan basis. It is to be returned to \_\_\_\_\_  
Home Care Agency upon discontinuation of Telehomecare Services.

### Telehomecare Equipment issued:

EQUIPMENT	YES	NO
Television Monitor		
ViaTV Camera Unit		
Tripod with tray		
Speakerphone with batteries		
Electric power strip		
Electrical adapter, 3-prong		
Telephone wall jack adapter		
Single to double phone jack		
Heavy duty extension cord		
Telephone extension cord-25'		
Telephone extension cord-12'		
Light with bulb(s)		

I will be financially responsible for loss of or damage to the above equipment.

**Exception:** The patient is not responsible for failure due to normal usage of equipment.

I have read and understand the Telemedicine Equipment Agreement.

\_\_\_\_\_  
Patient Signature

\_\_\_\_\_  
Date

**Patient Consent for Scott County Study**  
**Effect of TeleHome Health Care Monitoring on Chronic Illness**

You understand that your health care provider has recommended you to participate in the telehome health care study of the Mountain People's Health Councils and the University of Tennessee Medical Center (hereafter known as the Medical Center). The purpose of telehome health care is to provide health care and educational services using video conferencing and physiologic monitoring technology. You understand this is a relatively new use of the technology to deliver health care services and, as such, is different from a direct patient-to-physician or patient-to-home-health-nurse visit.

You also understand that you are participating in a study of how well telehome health care can help control chronic illness.

You authorize the release of any relevant medical information pertaining to you to the Medical Center or their agents. You consent to the use of your name and the disclosure of any identifying information including, but not limited to, your age, social security number and birth date that are required to conduct a medical encounter. You also authorize medical information about you to be released to the Health Care Financing Administration and its agents.

You further agree to be interviewed, and that this interview and your image may be audiotaped, videotaped, filmed or photographed. You understand that these recordings will be used for program evaluation, research and medical encounter purposes only and that your identity will not be disclosed except where medically necessary. I understand that without prior written consent said recorded images will not be displayed, broadcast or otherwise shown outside the health care setting. You understand that you are not entitled to, nor will you receive, any royalties or other compensation for participating in this study.

**Authorization of Medical Release:** You authorize any health care provider examining and /or treating you to release to any third party (such as an insurance company or government agency) any medical information request for use in determining claim for payment. You understand that you are responsible for non-covered charges.

You understand that you (and/or) your health care provider will communicate via interactive video conferencing equipment under the supervision of the University Medical Center in Knoxville, Tennessee. You further understand that some portions of a physical examination may be conducted and that you can request that the examination and/or videoconference be discontinued at any time. In the event the telehome health care encounter is videotaped, filmed or photographed, these images will become part of your medical record retained at the Medical Center and subject to the Center's policies regarding patient medical records.

If you have question about the study, you understand that you can call Medical Director, at xxx-xxxx.

If you have questions about your rights as a health program participant, you understand that you can call the Office of the Institutional Review Board at xxx-xxx-xxxx.

Although study results may be published, your confidentiality will be maintained. Your name or information identifying you will not be released without written permission unless required by law. Under federal privacy regulations, you have the right to determine who has access to your personal health information (called “protected health information” or PHI). PHI collected in this study may include your medical history, the results of physical exams, lab tests, x-ray exams, and other diagnostic and treatment procedures, as well as basic demographic information. By signing this consent form, you are authorizing the researchers at the University of Tennessee Medical Center to have access to your PHI collected in this study and to receive your PHI from Sam Burgiss, Ph.D and the University of Tennessee Medical Center where you have received health care. In addition, your PHI may be shared with other persons involved in the conduct or oversight of this research, including the (FDA) Food and Drug Administration, the University of Tennessee Medical Center, and the University of Tennessee Graduate School of Medicine Institutional Review Board. Your PHI will not be used or disclosed to any other person or entity, except as required by law, or for authorized oversight of this research study by other regulatory agencies, or for other research for which the use and disclosure of your PHI has been approved by the IRB. Your PHI will be used indefinitely. You may cancel this authorization in writing at any time by contacting the Principal Investigator listed on the first page of the consent form. If you cancel the authorization, continued use of your PHI is permitted if it was obtained before the cancellation and its use is necessary in completing the research. However, PHI collected after your cancellation may not be used in the study. If you refuse to provide this authorization, you will not be able to participate in the research study.

If you cancel the authorization, then you will be withdrawn from the study. Finally, the federal regulations allow you to obtain access to your PHI collected or used in this study. However, in order to complete the research, your access to this PHI may be temporarily suspended while the research is in progress. When the study is completed, your right of access to this information will be reinstated

***You have read this document carefully, and hereby consent to participate in the study under the terms described above. The above release is given on behalf of \_\_\_\_\_ because the patient is a minor or has been determined to be incompetent to give medical consent.***

Patient Signature \_\_\_\_\_ Date \_\_\_\_\_

Parent Signature \_\_\_\_\_ Date \_\_\_\_\_

Child Signature if over age 6 \_\_\_\_\_

Witness \_\_\_\_\_ Date \_\_\_\_\_

**Buckeye Quality Home Care Services****Provider Demographics**

Date: \_\_\_\_\_

Provider: \_\_\_\_\_

1. When did you start using telemedicine within this system?  
       \_\_\_\_\_ Month       \_\_\_\_\_ Year
2. Approximately how many patients have you seen using telemedicine?  
       \_\_\_\_\_
3. Approximately how many patients have you referred to telemedicine?  
       \_\_\_\_\_
4. Have you received any formal training in telemedicine?  
       \_\_\_ Yes (Please specify.) \_\_\_\_\_  
       \_\_\_ No
5. My main reason for using telemedicine is because: (Please check all that apply.)  
       \_\_\_ Employment requires it  
       \_\_\_ Desire to improve patient access to care  
       \_\_\_ Opportunity to expand client base  
       \_\_\_ Increased Income  
       \_\_\_ Other (Please specify.) \_\_\_\_\_
6. What is your specialty?  
       \_\_\_ Primary care physician  
       \_\_\_ Physician specialty/subspecialty \_\_\_\_\_  
       \_\_\_ Physician assistant  
       \_\_\_ Physical therapist Registered nurse  
       \_\_\_ Nurse practitioner  
       \_\_\_ Dentist  
       \_\_\_ Pharmacist  
       \_\_\_ Social worker  
       \_\_\_ Psychologist  
       \_\_\_ Nutritionist/dietitian  
       \_\_\_ Other \_\_\_\_\_ (over)

---

**Buckeye Quality Home Care Services**

7. What is your primary practice setting? (Please check all that apply.)
- |  |  |
|--|--|
| <input type="checkbox"/> Academic medical center         | <input type="checkbox"/> Community health clinic             |
| <input type="checkbox"/> Hospital                        | <input type="checkbox"/> Nursing home/assisted living        |
| <input type="checkbox"/> Outpatient Clinic               | <input type="checkbox"/> Inpatient/residential mental health |
| <input type="checkbox"/> Outpatient mental health clinic | <input type="checkbox"/> Home health agency                  |
| <input type="checkbox"/> Private office                  | <input type="checkbox"/> Other _____                         |
8. How many years have you practiced in this setting? \_\_\_\_\_
9. How are you employed? (Please check all that apply.)
- |   |  |
|---|--|
| <input type="checkbox"/> Self-employed (private practice) | <input type="checkbox"/> Employed by provider organization |
| <input type="checkbox"/> Employed by HMO                  |  |
| <input type="checkbox"/> Employed by health care facility | <input type="checkbox"/> Other _____                       |



## Chapter Nine

---

### Mental Health

**Authors:** Thelma McClosky Armstrong, MA, Eastern Montana Telemedicine Network  
Rob Sprang, MBA, University of Kentucky

#### I. Introduction

The goal of this technical assistance document is to provide an overview of the critical success factors to be considered when developing telemental health services. This paper draws from the collective knowledge gained from successful telemental health programs throughout the country.

Definitions:

Telemental Health: the provision of mental health services via telecommunication systems that enable two-way interactive “real-time” communication between the patient and the provider.

Telepsychiatry: the provision of psychiatric services via telecommunication systems that enable two-way interactive “real-time” communication between the patient and the provider

E-Therapy: the delivery of mental health services online. Online services are typically delivered in the form of email communications, discussion lists, or live chat rooms.

#### II. Background

Mental health services provided at a distance through telecommunications technology is not a new concept. In fact, documented use occurred in the early 1950’s. Advances in telecommunication and videoconferencing technology in the early 1990’s had a significant impact on the growth of telemental health/telepsychiatry service provision. In

1995, the American Psychiatric Association adopted a position statement on the ethical use of telemedicine:

*The American Psychiatric Association supports the use of telemedicine as an appropriate component of a mental health delivery system to the extent that it is in the best interest of the patient and is in compliance with the APA policies on medical ethics and confidentiality.* (American Psychiatric Association, [www.psych.org](http://www.psych.org), August 14, 2003)

Historically, telemental health/telepsychiatry services have been the most highly used services among all telehealth applications. The 2001 ATSP Report on US Telemedicine, reported that 11,184 telemental health encounters were conducted by their survey sites. Scarcity of psychiatrists and other mental health professionals in rural and urban undeserved areas played a major role in the early growth and continued expansion of these services. By using telehealth technologies, limited and geographically dispersed mental healthcare professionals can serve a wider patient base without travel.

Several benefits have been identified when telemental health/telepsychiatry services are introduced into a mental health care delivery system:

- Improved access to care;
- Provision of a higher level of care locally or in a more timely fashion;
- Timely Medication management;
- Improved continuity of care;
- Family involvement;
- Improved treatment compliance; and
- Coordination of care.

In addition, cost savings in out-of-pocket expenses for patients have been well documented. As an example, the 866 mental health encounters conducted over the Eastern Montana Telemedicine Network from July 2002 – June 2003 represents over \$260,000.00 in out of pocket savings for patients. These savings were based on travel cost and lost wages. Similar savings have been documented by other telehealth

networks across the country. Patients report high satisfaction with services that are provided in this manner. On a patient satisfaction scale of 1-8, 1 being not satisfied and 8 being very satisfied patient receiving telemental health service through the Eastern Montana Telemedicine Network reported an average of a 7.0 satisfaction rating for 5 consecutive years.

There are very few mental health services being provided today that cannot be offered through telehealth technologies. This is evident by the breadth of services offered throughout the country. Clinical applications include diagnostic and therapeutic modalities that are provided to all ages. Services can be provided for a broad range of diagnoses. Treatment limitations are more likely to depend on the specific patient's need versus diagnosis. For example, a mental health provider may not choose to see a patient with a diagnosis of major depression because the patient may have a high agitation level. Telemental health/telepsychiatry services should be seen as a tool in the armamentarium of care. Utilizing telehealth as a tool to augment a mental health care delivery care system is an important strategy in the successful development of telemental health/telepsychiatry services.

The most common telemental health/telepsychiatry services are provided through interactive videoconferencing technology and include pre-hospitalization assessment and post-hospitalization follow-up care, medication management, and consultation. Services in the area of psychotherapy and counseling, crisis intervention, and employee assistance programs are common as well.

Telehealth technologies also provide a mechanism for cost-effective provision of specialized services. They include: services for consumers who are deaf or hard-of-hearing, psychiatric services to rural nursing homes, substance abuse services, services to infants and children with special needs, school based telemental health services and the provision of care directly into the home.

There has been a recent increase in the use of POTS (plain old telephone service) video phones to provide services into the home for the chronically mentally ill, hospice,

family support and home assessments. These systems run on one residential phone line, are easy to install and provide a cost effective way to support both audio and video connections into the home.

The Kentucky Telecare program at the University of Kentucky utilizes POTS video equipment to provide child psychiatric consults to an elementary schools clinic. They also conduct in home ADHD assessments, pain management psychotherapy and Death and Dying Therapy all over POTS video equipment.

Additionally, telehealth technologies can augment and support an existing system of care. For example, a family visit can be conducted at a distance. Group meetings and support groups can occur in isolated areas. In small rural communities, it can be very difficult to develop and maintain a support group. By using telecommunication technologies, a multi-site support group can develop. The Appal-link network in southwest Virginia reports that multiple support groups have formed for individuals who have family members with mental illness. The Eastern Montana Telemedicine Network conducts one of the only telehealth twelve-step programs in the nation. Commitment hearings, clinical supervision, continuing education, and other administrative support activities are common applications of the technology as well.

As stated previously for the most part telemental health/telepsychiatry services have been provided through interactive video conferencing technology. Recent trends have seen an emergence of internet/web based services such as e-therapy and consumer support sites. Dr. John Grohol, PsyD states:

*E-therapy is a new modality of helping people resolve life and relationship issues. It utilizes the power and convenience of the Internet to allow simultaneous (synchronous) and time-delayed (asynchronous) communication between an individual and a professional. (Grohol,1999).*

There is significant interest among the Mental Health community in the provision of care via the Internet. At the same time it is considered controversial. Unlike face to face psychotherapy e-therapy still is very much in the process of defining itself. The lack of practice guidelines and the lack of a process for provider authentication cause concerns

among many mental health professionals. Individuals with mental health disorders can be extremely vulnerable. To date the practice of e-therapy is mostly unregulated. When considering the development of telemental health/telepsychiatry services it is important to keep abreast of all emerging trends in care models such as E-therapy as it is described above.

Today the point of delivery for telemental health/telepsychiatry services is as varied as the type of services that are being provided. Sites include hospitals, emergency rooms, community mental health centers, clinics, physician offices, nursing homes, assisted living facilities, prisons, schools, and even in the home.

With careful planning, telemental health/telepsychiatry services can significantly impact the quality, timeliness, and availability of services in a mental healthcare delivery system.

### **III. Guide to Creating a Successful Telemental Health Program**

The U.S. Surgeon General's Report on Mental Health in 1999 showed that the majority of people who are thought to have mental disorders do not presently seek out or obtain professional treatment. The root causes of people not seeking or obtaining professional treatment are many, but clearly lack of access to mental health providers contributes to this dilemma. Telemental health services hold great promise in meeting the unmet needs of individuals that require access to mental health services. The goal of this technical assistance document is to outline the elements for the development of a successful and sustainable telemental health program. There is no one size fits all answer. Multiple factors will affect the success of any individual program, but there are several critical success factors that should be considered during program development.

#### **A. Planning a Telemental Health Program to Meet the Needs of Underserved**

##### **Critical Success Factors:**

In the initial planning phase one should consider the importance of needs identification, resource and partnership development, and strategic planning. Needs

identification can vary from a somewhat simple to a more complex process. For example when the Eastern Montana Telemedicine Network began in 1993 there were no psychiatrists practicing east of Billings. All regional outreach clinics by psychiatrist had been suspended. For patients needing to be followed by a psychiatrist this meant up to a six hour drive one way. The need was apparent.

In more populated areas with greater resources and more complex systems of care, needs identification may be more subtle and complex. When conducting a needs assessment it is important to identify the critical services needed in the area to be served. Identify clinical resource that will meet those needs. Identify potential collaborators and competitors. Understanding the environment and population to be served will assist in the development of a comprehensive and successful strategic plan.

Needs identification may be the easy part. A greater challenge may exist in finding the mental health professionals that are willing to provide the service. In developing a telemental health program consider identifying clinical capacity prior to uncovering need at the rural, distant site or underserved site. A match between capacity and need must occur for providers to adopt telemental health. Across the country the most successful telemental health programs have developed in systems of care whose core business is to provide mental health services to geographically dispersed populations. Examples include the Northern Arizona Regional Behavioral Health Telemedicine Network and Appal-link Network of Virginia. Both of these programs identified the need to distribute limited professional resources in the most cost effective, clinically appropriate manner.

Strategic planning will be the cornerstone of a successful telemental health program. A clearly defined system of care with a strong financial model must be developed to support long term sustainability. In developing the financial model it is important to understand what sources of revenue exist.

What is the reimbursement policy for the services to be provided? Reimbursement policies for telemental health/ telepsychiatry services vary from state to state. Several

state Medicaid programs pay for mental health services provided through interactive videoconferencing. Check with the state Medicaid office for their policy. Medicare has limited reimbursement for telepsychiatry. To receive reimbursement for services provided to a Medicare beneficiary several criteria must be met. Beneficiaries are eligible for telehealth services only if they are presented from an originating site (physician or practitioner office, a hospital, critical access hospital, rural health clinic, or a federally qualified health center) that is located in either a rural health professional shortage area (HPSA) or in a county outside an MSA. Coverage is restricted to CPT codes 90801 and 90804-90809. Many telemedicine programs have been very successful in securing reimbursement from private payers. If reimbursement policy for telemental health services has not been established by a private payer for the most part this must be accomplished through individual negotiation.

Is there potential for contractual services? Contractual telemental Health services provided to correctional facilities have been successfully implemented in several areas of the country. Also consider potential expense reductions such as decreased emergency room visits or decreased medication usage.

Is there the potential for valued added benefit the the partner sites? Value added benefits might include the provision of continuing education, clinical supervision at a distance, administrative activities and communication between multiple agencies. The Eastern Montana Community Mental Health Center, a member of the Eastern Montana Telemedicine Network has branch offices in several of the communities served by the network. By having interactive videoconferencing available they can conduct meetings with all of their branch sites, provide supervision and share clinical resources. Two important lessons that have been learned by the field, providers will not provide services for free and partners will financially support network expense if valued added benefit can be documented.

## **B. Operational Considerations**

Once the strategic plan has been developed, there are several critical issues to consider before embarking upon implementation. First and foremost are the factors that

impact good clinical practice for in-person care. Those factors should be considered when implementing telemental health services.

### **Privacy, Confidentiality and Informed Consent**

Telemental Health services should be provided in an environment that ensures privacy and supports confidentiality. It is imperative to work closely with all partners to develop policies, procedure and protocols to minimize the potential of intrusion by individuals that are not directly involved in that patient's treatment. It is difficult to ensure strict privacy in any environment, but with careful planning patient privacy and confidentiality can be protected in a telehealth environment at the same level as an in-person environment. For example posting *do not enter* signs on the outside door of a telemedicine suite should notify individuals not to enter the room during a clinical encounter. Whenever possible the presence of non-clinical staff during a clinical encounter should be avoided. If it is necessary to have a technical person in the room at the patient or provider site it is critical to inform the patient that the person is in the room. Introduce all participants at the beginning of each clinical encounter. For further information on telehealth privacy issues refer to: *Privacy Report: Protecting Privacy When Using Telehealth Technology in Healthcare* - <http://tdrt.atcorp.org>.

As in any form of healthcare all patients should be made aware of the potential risks, consequences and benefits of the treatment they are receiving. It is recommended that a process for securing informed consent for telemental health services be developed. In addition it is recommended that all patients be given the choice of how they receive their care (in-person or through telehealth). And that they understand that in no way will care be withheld if a patient chooses not to participate in a telemental health encounter.

Another consideration in the area of privacy and confidentiality to consider are the HIPAA standards. These standards contain provisions to protect the privacy and confidentiality of any individually identifiable healthcare information. It has been recommended that no additional actions need to be taken for a telemental encounter if



services are provided via a dedicated or private network. The provision of telemental health services across the public Internet using IP based videoconferencing would require that the signal be encrypted. In any case, it is imperative that the existing HIPAA plan within the institution be followed to ensure that HIPAA standards are met.

## Medical Records

Medical records of a telemental health encounters should reflect the same process that occurs as in an in-person encounter. Consider including the following additional information in the record of a telehealth encounter: location of the patient; location of the provider; type of equipment used; technical issues, if any, that effected clinical care; and who was present during the encounter.

## Quality Improvement

As in all forms of clinical services, quality improvement (QI) plays a critical role ensuring the provision of quality patient care. Telemental health services should be systematically monitored and evaluated as a part of the overall QI process.

The Eastern Montana Telemedicine Network established a quality improvement checklist that is completed for every mental health encounter conducted on its network. The identified measures are based on established policies and procedures. The QI committee meets quarterly to review reports and develop action plan.

<b>MENTAL HEALTH CONSULTATIONS-PATIENT COMMENTS</b>
It was easy to schedule a telemedicine appointment
My privacy and confidentiality were protected during the consultation
I was able to communicate adequately with the specialist
The picture and sound were ok
The doctor/professional was on time for the appointment
The site facilitator was there to assist me as needed
Overall, I was satisfied with today's session

<b>CONSULTANT COMMENTS</b>
The telehealth equipment worked properly for this consultation
Prior to or during the consultation, I had adequate access to this patient's records/tests
I was able to communicate adequately with the patient
The participation of the presenter was essential to obtain an adequate history or information
The examination conducted during the consultation was adequate
I felt the privacy of the session was respected
I felt the patient was satisfied with the consultation
Overall, I was satisfied with today's consultation

## Licensure

Licensure requirements will vary from state to state. Providing telemental health services across state lines requires compliance with the licensing regulations in the state in which the patient will be seen. In most states telemedicine licensure information can be obtained through the Board of Medical Examiners. For example if a Montana psychiatrist provides mental health services to a patient located in Wyoming he/she must adhere to the Wyoming medical licensure regulations which require a full medical license. But if a Wyoming psychiatrist provides services to patient in Montana he/she would be required to carry a limited license for telemedicine in Montana, not a full Montana license.

## C. Technical Analysis

### Equipment

As stated earlier, interactive videoconferencing technology is used in the majority of telemental health programs. Typically the equipment includes a video conferencing CODEC that runs either H.320 or H.323 video, an appropriate size monitor based on the room size, a pan tilt zoom camera, and a microphone. Optimally this equipment will be the same the remote and local site. When setting up a room for telemental health, consider including a fax machine and an open phone line at the distant and originating sites. Additionally, consider setting up the room at the sending and receiving sites as mirror images of each other. This provides a feeling of connectedness between the two

environments. Remote camera control is a feature that clinicians find useful. When necessary a clinician can pan, tilt and zoom the camera on the patient end for close-ups. This function has been extremely useful in assessing extra pyramidal symptoms for patient on anti-psychotic medications.

### Transmission speed

Typically most telemental health programs use systems that transmit data at 384 kbps. Although not a standard, this speed is used most often in clinical encounters. There have also been several effective telemental health programs that have used videophones, which run at a much lower bandwidth (56kbps). Remember equipment selection should be based on the type of service to be provided and the effectiveness of that equipment in providing the appropriate clinical information.

During the equipment selection process consider contacting programs that have a successful track record. Information provided by seasoned programs can be valuable and critical to success. In addition, it is suggested never to buy equipment that has not been tested in the intended environment. Local and long distance telecommunication carrier configurations also have an impact on how well equipment may work. Vendors are very willing to provide demonstrations of their equipment. Whenever possible talk to someone who is actually using the equipment in a similar setting before purchasing.

### Cost of equipment

Cost can vary greatly. Interactive video technology can run as little as \$500-\$700 for a low bandwidth videophone or as much as \$10,000-\$15,000 for high-end videoconferencing unit. It is important to remember not to compromise quality because of cost. Failure to purchase the appropriate, reliable equipment for the application can be extremely detrimental to the success of the program. The most important factor in determining type of equipment should be quality of transmission as it relates to the clinical encounter.

For more technical information see the OAT Technical Guidelines at <http://telehealth.hrsa.gov/pubs/tech/techhome.htm> and for more information on equipment see the TDRT website at <http://tdrt.aticorp.org>.

#### **D. Operational Considerations**

Critical to the success any telemental health program is the availability of human resources to manage the operational, technical and clinical aspects of the application.

It is important that there are key personnel at each end of the video equipment to ensure operations run smoothly and the needs of the patient and providers are met. When assessing human resource needs, many in the field have found it valuable to assess the processes that occur when the same service is provided in-person. This analysis can provide a road map for identifying the development of policies and procedure and the appropriate staffing to implement the services.

Many successful programs have site coordinators at the originating and distant site. The responsibilities of a site coordinator include overseeing the day to day operations, ensuring that all activities related to patient care encounters are organized and coordinated; including scheduling, appointment management, client charts, paperwork, and data collection. Clearly site coordinators may be the most critical people in the success of the program. They are on the front line interfacing with both the patient and the provider.

Having the proper technical support staff to monitor and maintain the equipment and network is also critical to success of the network. Within the telehealth environment there is very little tolerance for technical malfunctions.

A medical director can be an asset to the project as well. A medical director can provide clinical guidance to the network and interface with clinical and administrative staff. They can also play a critical role in relationship development with regional partners as well.

In addition to the human resources it is critical to develop policies and procedures to ensure consistent implementation: Although not all-inclusive, listed below are several key policies to consider:

- Release of information and Informed consent;
- Privacy and confidentiality;
- Intake procedure and screening;
- Staff roles and responsibilities;
- Transmission of patient data;
- Appointment scheduling;
- Transmission of prescriptions, lab orders and progress notes;
- Evaluation and outcomes;
- Quality Improvement; and
- Safety.

Last but not least it is critical to have a systematic process for initial and ongoing training of clinical, technical and operational staff to ensure that quality is supported throughout the system.

The following is an outline of steps to consider in the development of telemental health services within the organization.

### ***Start-up to first 30 days***

- Initial meetings with stakeholders to discuss clinical, technical and logistical implementation strategies.
- Determine appropriate technology and bandwidth requirements.
- Determine appropriate location of equipment.
- Apply for Universal Service subsidies for telecommunication services, if applicable.
- Begin negotiation with third party payers.

### ***31-60 days***

- In collaboration with all stakeholders develop policies, procedures and protocols.

- Order equipment and telecommunication services.
- Develop marketing, educational and training materials.
- If necessary remodel rooms that will house equipment.
- Develop evaluation tools.
- Develop administrative processes to include billing, scheduling, technical support and ongoing operations.

### **61-90 days**

- Configure network.
- Install equipment.
- Test equipment .
- Conduct training sessions.
- Finalize administrative processes.
- Conduct trial cases.

Once the service becomes operational it is critical to utilize evaluation data and quality improvement activities to monitor progress toward the clinical and strategic goals.

Refinements and adjustments to the clinical and administrative process can occur at anytime.

## **IV. Lessons from the Field**

- High quality audio is essential to the success of telemental health services. Microphone type and placement is extremely important. For example, if working with a depressed patient whose head is lowered, the microphone should be placed in front of the patient on the table. For active children or adolescents, or agitated adult patients will be seen then a multi-directional microphone should be used.
- It is important to recreate the in-person encounter providing a safe and therapeutic environment:
  - Design the physician and patient site to have a similar in look and feel;

- Create a “reception” area for the patients; and
  - Request that a “staff” person at the originating site be present to assist with the video connection and facilitate the beginning of the session. If possible the staff member should leave the session once it begins.
- Remote camera control is an important feature for psychiatrists. This function enables the physician to “zoom” in on a patient to assess for extra pyramidal symptoms without requiring an operator in the room.
- It is critical to provide initial and ongoing training to all telemental health providers and staff that support the service.
- To ensure ongoing quality a quality improvement process should be developed.

## V. References:

American Psychiatric Association, *APA Resource Document On Telepsychiatry Via Videoconferencing*. [http://www.psych.org/pract\\_of\\_psych/tp\\_paper.cfm](http://www.psych.org/pract_of_psych/tp_paper.cfm). August 13, 2003

Britain, Catherine, *Rural Telemental Health - A Ten-year Perspective*, Next Generation Healthcare. October 2001

Grohol, John M, Psy.D, *Best Practices in e-Therapy* May 14, 1999  
<http://psychcentral.com/best/>

*Telemental Health/Telepsychiatry Operations and Implementation Manual for County Mental Health Plans*, California Institute for Mental Health, November 2003

*Telemental Health: Delivering Mental Health Care at a Distance - A Guide for Rural Communities* - <http://telehealth.hrsa.gov/pubs/mental/intro>

Wooten, Richard, Yellowles, Peter, McLaren, Paul, *Telepsychiatry and e-Mental Health*, Royal Society of Medicine Press Ltd., 2003

## Useful Resources

### Web sites:

American Psychiatric Association – [www.psych.org](http://www.psych.org)

American Psychological Association – [www.apa.org](http://www.apa.org)

Centre for Online Health - [www.coh.uq.edu.au](http://www.coh.uq.edu.au)

Telemental Health: Delivering Mental Health Care at a Distance - A Guide for Rural Communities - <http://telehealth.hrsa.gov/pubs/mental/intro>

Wooten, Richard, Yellowles, Peter, McLaren, Paul, Telepsychiatry and e-Mental Health, Royal Society of Medicine Press Ltd., 2003

### CPT codes

- 90801- Psychiatric Diagnostic Interview Examination
- 90804-90809 – Insight Oriented, Behavior Modifying or Supportive Psychotherapy, Office or Outpatient with or without medical evaluation and management

## **VI. Sample Clinical Protocol – (next page)**



## **MENTAL HEALTH CLINICAL PROTOCOL**

### **INTENT:**

To ensure mental health services are performed in an appropriate, confidential, safe, and efficient manner.

### **PRACTICE:**

Appropriate patient for telemedicine consultations include:

Various psychiatric conditions. Medication check follow-ups. Patients, who in the opinion of their physician, can receive examinations via the telemedicine system or those patients that have been referred by their primary care physician for a condition appropriate to be seen by a specialist through the use of the videoconferencing equipment.

### **PROCEDURE:**

#### **Scheduling**

1. The client must contact their physician's office to request an appointment.
2. The physician's office will then schedule an appointment with EMTN (see Event Scheduling Policy).

#### **Clinical encounter**

1. Connection for the site the patient will be attending should be made 10-15 minutes prior to the scheduled appointment time
2. The site facilitator at the patient site should assure there is good audio and video connection with the site facilitator or network staff at the physician site.
3. For new patients the site facilitator will explain the technology to the patient. They should make sure the patient is comfortable with the videoconferencing equipment and the planned encounter.

4. The site facilitator with the patient should make sure the physician/ or another staff member is present at that site before leaving the client in the room by him/herself.
5. Protection of the patient's privacy should be maintained at all times. Measures to accomplish this such as screens or blocking of windows should be taken. Signs that state a telemedicine consultation is being conducted should be placed on the outside of the telemedicine rooms, so others do not inadvertently interrupt the conference.
6. When conducting clinics that move from site to site, the physician should hang up his active call before the staff person managing the bridge will move him/her to the new site. The physician can also call the network office and ask to be moved to the next patient location.
7. The site facilitator is responsible for obtaining a completed questionnaire from the patient (and the local provider present on site when applicable) after the completion of the encounter.
8. The site facilitator or network staff is responsible for obtaining a completed questionnaire from the treating physician.

**Safety**

1. If EMTN or other network site facilitators believe that a safe environment is not being provided at any given time, the site may request permission from the physician to monitor the patient encounter.
2. If there is still a concern about patient safety from the local site facilitator and it cannot be resolved with the physician, contact the EMTN office for assistance in resolving the matter.

## Chapter Ten

---

### **Telepharmacy**

**Authors:** Charles D. Peterson, Pharm.D., North Dakota State University  
Howard C. Anderson, Jr, RPh, North Dakota State Board of Pharmacy

#### **Contributing Editors:**

Denny Lordan, Northwest TeleHealth  
Jac Davies, Northwest TeleHealth  
Jan Constable, Northwest TeleHealth  
Larry Bettsworth, Northwest TeleHealth  
Margie Lockyear, Northwest TeleHealth

#### **I. Introduction**

The purpose of this technical assistance document is to provide valuable information and guidelines for pharmacists, rural communities, and others on how to successfully implement a telepharmacy program designed to restore and retain retail and hospital pharmacy services in communities that are located in remote medically underserved areas. Through use of telepharmacy technology, pharmacy services can be restored and retained in remote rural communities satisfying all board of pharmacy rules and regulations using the same quality standards used in traditional pharmacy practice including pharmacist prescription verification before dispensing, drug utilization review, and patient education counseling. Telepharmacy services produce the same quality of pharmacy services as the traditional mode of delivery and provide additional value-added features that are not found with traditional pharmacy practice.

This technical assistance document was funded via a supplement award to the North Dakota Telepharmacy Project grant number 1D1BTM 00051-01 from the Office for the Advancement of Telehealth, Health Resources and Services Administration, Department of Health and Human Services, award issued September 1, 2002.

---

Access to quality pharmacy services is very important to the proper use of medications and to the reduction of medication errors. As modern medications become increasingly potent and capable of curing and mitigating disease, pharmacy (and involvement of the pharmacist) becomes more and more important in ensuring rational, safe, and cost-effective use of medications for the public.

Rural communities across the country are struggling with declining and aging populations, shortages of health professionals, declining access to health care and loss of local businesses. In many cases, mail order is the only pharmacy services available to the public unless they are willing to travel great distances to obtain their prescription medications. Often the poor and elderly in these communities are the least able to access and utilize mail order pharmacy services. Patients obtaining their prescriptions by mail order who have questions regarding their medications find no pharmacist to ask. Loss of access to local services sometimes necessitates patients moving to other communities to be closer to services. This can upset both their family and community life. At the same time it causes negative economic consequences for the community they leave. The resulting out migration is one of the most serious problems affecting many rural areas. Rural Health Clinics have done an excellent job of providing basic primary care to patients living in rural areas but often the pharmacy services have not followed.

One of the biggest challenges facing the profession of pharmacy today is closure of rural community pharmacies. Most of these smaller rural communities have only one pharmacy, and one pharmacist who has been faithfully serving the public's health care needs for decades. The pharmacist owners in these communities are at the age when they want to retire and sell their stores, but they are having great difficulty doing so. Rural communities have always had difficulty recruiting health care professionals to practice in the smaller towns. These difficulties are now being compounded by a nationwide pharmacist shortage. The current pharmacist shortage has driven pharmacist salaries beyond what rural communities can afford and thus they currently have little or no chance of recruiting a pharmacist to take over the local drug store and therefore are being forced to close. For these rural communities, this is a great loss because the

pharmacist is often one of the few health care providers in the community. So by these communities losing their pharmacies they are essentially losing access to health care and over time this will have a major negative impact on the health and wellness of Rural America.

In addition to the closure of their pharmacies, rural communities are also facing severe pharmacist shortages in their hospitals. Experienced hospital pharmacists are a critical part of the hospital health care team. They bring extensive knowledge of the complex issues that arise when dealing with severely ill hospitalized patients who are on multiple medications and have complicating health factors. Attracting and keeping hospital pharmacists in rural communities is as difficult as attracting and keeping retail pharmacists. When a hospital has only one pharmacist, there is severe pressure on that individual to meet all the facility's needs. Burnout is a real problem. The rate of pharmacy staff turnover in small hospitals is twice as large as it is in large hospitals. This problem, especially when combined with the retail pharmacy shortages, presents a serious health risk for rural communities.

Telepharmacy is a unique and innovative way to deliver a full service pharmacy operation including pharmacist drug utilization review and patient education counseling at a remote rural site which incorporates all the safe practices offered by the traditional mode of delivery. Through telepharmacy, rural communities can have their pharmacy services retained or restored without a licensed pharmacist needing to be physically present in the community, pharmacy, or hospital. Potential benefits to these rural communities from telepharmacy services include: restoring access to health care, pharmacy services, and pharmacists; reducing medication errors in hospitals; bringing hospitals into compliance with state boards of pharmacy rules and regulations; providing rural clinicians with expertise in medication issues associated with special populations, such as pediatrics or patients on coagulation therapy; improving community economic development by building new businesses and adding new jobs; improving the chances of recruiting or retaining pharmacists in rural communities to practice pharmacy; and providing new clinical training sites for pharmacy students at the University and teaching

them how to deliver pharmacy services to rural communities in a unique and innovative way utilizing the latest advances in technology.

It should be stressed that this model of providing retail telepharmacy services is different than others being proposed in that it includes and retains the active role of the pharmacist as the primary health care provider in the delivery of pharmacy services. This is done to achieve the highest standard of quality for delivering pharmacy services to rural communities and is also for the protection, safety, and welfare of the public related to ensuring the proper use of pharmaceuticals. This is a value added quality assurance feature which is often lacking in other telepharmacy models that exclude pharmacist involvement resulting in no formal drug utilization review or patient education counseling. Pharmacist involvement is essential. Exclusion of the pharmacist could potentially increase risks to the patient leading to a higher incidence of medication errors, side effects, excessive drug costs, and uncontrolled disease. Examples of models which often exclude the role of the pharmacist, particularly in providing pharmacist patient education counseling, include internet pharmacies, mail-order pharmacies, delegated models which delegate the pharmacist duties to another health professional, and vending machine models.

Types of pharmacy services:

#### 1. Traditional Pharmacy

Most rural communities want a full service pharmacy which supplies a complete line of health related goods and services. Full service pharmacies provide a complete inventory of prescription and nonprescription drugs, including upfront merchandise such as health and beauty aids, and convenience items. Most full service pharmacies in rural areas will have an inventory of approximately 300 or more prescription drugs. Prescriptions are prepared on location in the pharmacy with the patients picking up their prescriptions at the same store they were prepared. Pharmacists provide drug utilization review and patient education counseling at the point of sale.

## 2. Remote Consultation Sites

In remote consultation sites, there is no prescription drug inventory at the site and it does not require a registered pharmacy technician. Twice each day a courier picks up and delivers prescriptions filled by a pharmacist at a central pharmacy site a short distance away. Prescriptions are prepared at the central pharmacy, delivered to the remote rural site and the patient education counseling is provided by the pharmacist via an audio and video computer link. This model is used by a pharmacist at a central pharmacy site who is serving a rural community a short distance away and who does not wish to manage two separate prescription drug inventories at both the central pharmacy and remote site.

## 3. Hospital Telepharmacy

In these locations prescriptions that are issued at rural hospitals are electronically sent to an urban medical center pharmacy, where they are reviewed, processed, and verified by hospital pharmacists. The hospital pharmacist has access to the patient's electronic medical records, and checks the prescription for proper dosing, allergies, duplication of drug therapy and drug interactions. Then the pharmacist electronically authorizes the dispensing of the prescription through a specialized Automatic Dispensing Device (ADD). The prepackaged medication is released electronically via the ADD. A nurse in the rural hospital, with password authorization to the ADD work station, double checks the medication and label, prior to administering the medication to the patient. The pharmacist at the urban medical center is able to electronically monitor the verification process and to oversee the restocking of the ADD via a videoconferencing link. The video conferencing system is also used for consultations between the patient, nurse or physician with the urban hospital pharmacist.

The ADDs used in hospital applications contain a much larger array of medications than the clinic-based ADMs described below. In addition to providing controlled

access to medications, the ADDs provide hospitals with complete inventory control. This not only aids hospitals in managing medication, but also improves their ability to bill for medications dispensed. This has proven to be a significant source of cost recovery for small, rural hospitals.

In many remote rural areas, rural hospitals are served by a local retail pharmacy. In these instances, a full inventory of prescription drugs is located at the hospital and is managed and maintained by a registered pharmacy technician with remote supervision by a licensed pharmacist at the retail pharmacy using telepharmacy technology. In these locations a registered pharmacy technician prepares the medication for final dispensing to the hospital floor, nursing home, or swing bed patient. The medication is checked by the licensed pharmacist, via the telepharmacy links, and is released (dispensed) to the floor or patient. The licensed pharmacist at the retail pharmacy signs a consulting contract with the rural hospital to deliver pharmacy services.

#### 4. Automated Dispensing Machines

Some Rural Health Clinics may have need for an automated dispensing machine. The prescriber's drug order is provided to the licensed pharmacist at a central pharmacy site electronically or by fax. The licensed pharmacist checks the patient profile, does proper drug utilization review and then instructs the dispensing machine to release the medication. The patient is then counseled, by the pharmacist, via the audio and video computer links. Automated Dispensing Machines have limited drug inventory (i.e. generally 20 most frequently used medications) and they are usually designed for an urgent dose or first dose to get the patient initially started on their medications (i.e. initiating antibiotic treatment for infection). Patients still require the services of a traditional pharmacy to obtain their maintenance doses to complete their prescription. Telepharmacy Solutions, Inc is one vendor that supplies automated dispensing units.



## II. Background

Telepharmacy in North Dakota allows the delivery of traditional pharmacy services, which include dispensing of medications and providing patient education counseling in rural communities that have lost, or are about to lose, their pharmacy.

In North Dakota a registered pharmacy technician, at the remote telepharmacy site, prepares the prescription for final dispensing by the pharmacist. The pharmacist, at the central pharmacy, checks the prescription for accuracy, and dispenses the prescription to the patient during the counseling session, using the telepharmacy, audio and video link. It is important to understand when dispensing actually occurs in telepharmacy. Dispensing of the product to the patient is always the professional function of a licensed pharmacist, and must not be delegated to the technician. As with telemedicine, nobody would define surgery as being conducted by a technician who lays the patient on the table in preparation for the physician to operate the computer assisted surgery equipment over the long distance communication link. Likewise, nobody would ever consider the radiology technician, who is assisting with the patient's scan (e.g, mobile MRI) at a remote location, to be doing the actual diagnosis of the scan. In the same manner, the dispensing of the pharmaceuticals (an important professional function in the practice of pharmacy) should not be assigned to the technician, when that duty is actually performed by the pharmacist, using the telepharmacy tools. The pharmacy technician prepares the prescription for final dispensing, and the pharmacist does the actual dispensing, at the same time the patient education is provided.

Telepharmacy has been delivered, in other states, using a remote vending model where a limited supply of prepackaged medications is stocked in a vending device. The prescriber's order is entered into the pharmacy dispensing system, verified by the pharmacist and then the pharmacist directs the release of the medication by the vending device at the remote location. In this remote vending model, patient education counseling has been the responsibility of the prescriber.

Description of Hospital Telepharmacy Service in Washington State – The Telepharmacy program in Washington State is focused on addressing the health professionals'

---

shortage by providing the expertise of hospital pharmacists to small, rural hospitals. In some communities, this service is used by rural hospitals that have lost a pharmacist and have not been able to hire a new one. In others, where local pharmacists are available, the Telepharmacy system is used to assure that the hospital has full 24/7 pharmacist coverage when additional pharmacists are not available.

The hospital Telepharmacy program uses integrated data networks, medication dispensing devices, order verification and video-conferencing systems to allow nursing staff at the rural facility to have complete and timely interactions with hospital pharmacists located in an urban facility and to provide pharmacist oversight of pharmacy operations. Video units are installed on computers placed in the nursing stations and at pharmacy workstations and allow for 24/7 consultation with a pharmacist.

Nursing staff at the rural hospital enter prescriptions into a central pharmacy computer system and send a scanned copy of new prescriptions to the urban hospital pharmacy, where pharmacists review the patient's laboratory data and medication profile to insure the appropriateness of the medication. The hospital pharmacist then authorizes the nursing staff to dispense the medication via the automated dispensing device. Video units are used for consults between the nursing staff, physicians, and the pharmacists, and also to allow the hospital pharmacist to oversee the restocking of automated dispensing devices.

Policies and procedures are developed to address medication order entry, review and verification processes. The procedures also address the use of a remote camera for oversight of restocking automatic dispensing devices by nurse-technicians. Additionally an educational program is used to train selected nurses within participating facilities to gain licensure as certified pharmacy technicians for purposes of order entry and restocking of automated dispensing devices under the supervision of a pharmacist.

---

**Definitions:**

- A. “Remote site” means a full service pharmacy staffed by a registered pharmacy technician with access by computer, audio and video link to a licensed pharmacist at a central pharmacy site while open. The “remote site” is analogous to “originating site”, where the patient is located.
- B. “Rural telepharmacy hospital” means a small rural hospital receiving full- or part-time pharmacy support from an urban hospital pharmacy or local retail pharmacy. Rural hospitals are one category of “remote site.”
- C. “Telepharmacy” means a central pharmacy, either retail or associated with a hospital, with one or more remote sites in which all sites are connected via computer, audio, and video link. This is analogous to “distant site”, where the pharmacist is located.

### **III. Step-by-Step Guide to Creating a Successful Program**

#### **A. Starting A Telepharmacy**

##### 1. Become Familiar with the Laws and Regulations:

###### a. General principles & first point of contact

Pharmacy probably has more laws and rules in every state than any other area of health care. A careful analysis of existing state and federal laws and rules related to operating a pharmacy is necessary. In order to operate a telepharmacy program, the state must have laws and rules in place for allowing telepharmacy services to operate in the state, and the remote site must be properly licensed with the State Board of Pharmacy.

The State Board of Pharmacy should be the first point of contact when considering establishing telepharmacy services to ensure that the current rules and regulations allow this type of pharmacy to operate within the state,

and also to ensure that any future plans for establishing telepharmacy services are in full compliance with state law. The State Board of Pharmacy will provide the proper process to follow for officially applying for a telepharmacy permit.

b. License Application

The application for telepharmacy permit must be processed by the licensed pharmacist in charge of owning the businesses of both the central pharmacy and remote telepharmacy sites. In addition to the state license, the applicant must also obtain registration numbers from the National Council for Prescription Drug Programs (NCPDP - formerly NABP number) and the federal Drug Enforcement Administration (DEA). It is important that the licensed pharmacist obtain State Board of Pharmacy, NCPDP, and DEA registration numbers for each remote telepharmacy site which are separate from the central pharmacy site registration. The State Board of Pharmacy, NCPDP, and DEA registration numbers for both the central pharmacy and remote telepharmacy sites are not only important for operating legally within the state, but they also are needed for obtaining reimbursement from third party payers for telepharmacy services. The regulatory approval process may vary depending upon each state's rules and regulations and it may take 2-3 months or longer for approval of the telepharmacy operating permits.

For telepharmacy services that are based in a hospital pharmacy, a new license may not be necessary. In Washington State, the state board of pharmacy approved the program and is notified as each new site is added. In North Dakota, where rural hospitals are generally served by local retail pharmacies, the rural hospital receives its normal Class B permit from the board of pharmacy along with a Subclass K permit to operate a telepharmacy. The local retail pharmacy which serves the rural hospital receives its normal Class A permit along with a Subclass K permit for operating a telepharmacy service to the hospital.

c. Third Party Reimbursement

The North Dakota approach to telepharmacy programs mimic “business as usual”. The telepharmacies feature the same full service pharmacy operation as a traditional pharmacy. They are supervised by a licensed pharmacist; they are approved and licensed by the ND State Board of Pharmacy, NCPDP, and DEA; and satisfying all ND Board of Pharmacy requirements for the practice of pharmacy. In North Dakota, the remote telepharmacy sites are currently receiving reimbursement by third party payers for services rendered to patients.

Once the State Board of Pharmacy, NCPDP, and DEA registration permits are obtained, the remote telepharmacy site is eligible for third party reimbursement claims.

For the rural telepharmacy hospital program, dispensing of medication occurs at the facility where the patient is hospitalized. These hospitals submit claims for patient care, and reimbursement practices are not affected. The central Telepharmacy operation receives its funding from the participating rural hospital sites, which enter into a contractual agreement and pay fees to the Telepharmacy program for the services they receive.

d. Some specific state issues:

As of June 2003, North Dakota has telepharmacy laws and rules to allow a qualified pharmacy technician to operate a telepharmacy at a remote location under the technology-driven supervision of a licensed pharmacist. Nebraska has a delegated dispensing model which delegates the prescription processing function to non-pharmacist health professionals. Washington has a rule which allows remote dispensing devices, and obtained approval from its state Board of Pharmacy to allow pharmacy technicians to restock the remote dispensing devices under video-

conferenced supervision by a licensed pharmacist. Arizona has approved off-site verification of prescriptions, which should make telepharmacy easy. Other states, such as Minnesota and Iowa, approve telepharmacy requests on a case by case basis. The state of Texas is currently conducting a pilot program in implementing telepharmacy services to the western portion of the state. Alaska is currently conducting a demonstration project supported through HHS to bring medication to two remote, previously underserved communities, through the use of remote drug dispensing machines.

Once a state has its laws and rules in place for allowing telepharmacy services to operate in the state, and the remote site is properly licensed with the State Board of Pharmacy, plans can proceed to develop and implement the services.

## 2. Assess the Need

Rural communities require careful assessment to determine the need for, and the feasibility of, telepharmacy services. Questions need to be answered related to: Are pharmacy (and pharmacist) services currently available in the community? Is there health personnel in the community authorized to prescribe medications (i.e. medical clinic or other health facility) sufficient to support a telepharmacy operation? Is there a convenient cost-effective location to establish telepharmacy services? Is there support for establishing telepharmacy services from the: community, medical personnel, State Board of Pharmacy, local government and businesses, patients, telecommunications company, and pharmacists in the area ? Is there a licensed pharmacist in the area willing to establish and deliver telepharmacy services to the targeted rural community? Has a business plan been developed to assess the projected expenses and revenue necessary for the proposed telepharmacy services can be profitable and sustainable? Are there

sufficient resources available via private, local, and state support to establish such services?

When considering establishing a rural telepharmacy hospital program, a different set of questions should be asked. In particular is the nursing staff of the rural hospital willing to support a telepharmacy program? Is the hospital willing to invest in the technology necessary to support the program, and to pay fees to the central hospital telepharmacy? Is the State Board of Pharmacy willing to allow video conferencing technology as a mechanism for pharmacist oversight of nursing staff?

### 3. Develop Community Partners

Several community partners are needed to effectively implement telepharmacy services in rural areas. In selecting prospective communities for telepharmacy services, it is important to consider the following issues: community need, interest, and investment in the project; availability of a pharmacist at a central pharmacy site in a nearby community willing to deliver telepharmacy services to the remote site; and support from the State Board of Pharmacy. Priority should be given to those rural communities who have no pharmacy services or who are about to lose their pharmacy services. This will maximize the benefit of telepharmacy services to rural areas and minimize any potential conflict in local pharmacies competing for business.

In determining the level of support for telepharmacy services and defining the scope of services needed in the targeted community, feedback from the following project partners may be beneficial:

1. Individual Patients
2. Senior Citizen Groups
3. Rural Health Clinic Personnel
4. Community Business leaders
5. Local Community Leaders

6. Local Government Officials
7. Pharmacist Practicing in the area
8. State Board of Pharmacy Administrator
9. State Pharmaceutical Association
10. School of Pharmacy

As with retail telepharmacy services, rural communities where the hospital has no pharmacy services or is about to lose those services should be prioritized. If the community has some retail pharmacy capacity, the advocates of the hospital telepharmacy program should communicate with the retail pharmacists to keep them informed and to minimize any potential concerns over competition. These educational efforts should extend to others in the community with an interest in hospital operations, including hospital boards and advisory groups, ombudsmen, senior citizen groups, and labor organizations.

#### 4. Secure a Physical Location

##### a. Criteria to consider for location of retail telepharmacy services:

1. Convenient Access for the Public
2. Proximity to other Health Clinic Facilities
3. Proximity to Nursing Homes
4. Leased after Development by Local Communities
5. Owned by the Central Pharmacy
6. Leased for the Rural Health Clinic, if present.
7. Lease space in an existing business.
8. Technology Transmission or Connectivity Capabilities in the Community (DSL, T-1 lines available?)

State Board of Pharmacy rules and regulations pertaining to building, security, sanitary standards, and private consultation rooms must be considered in plans for the physical location of the pharmacy. Many



pharmacy wholesalers have departments to assist in pharmacy layout and designs. The area drug wholesaler generally keeps up with the current rules and requirements of the State Board of Pharmacy and they can be an excellence resource for developing construction plans for the pharmacy physical facility.

b. Criteria to consider for starting hospital telepharmacy services:

Hospitals need space convenient to nurses' workstations on patient floors and within the ER to locate automatic dispensing devices and fixed video equipment. The hospital pharmacy must also have space for fixed video equipment. The space around the automatic dispensing device should allow sufficient room for a cart with mobile video equipment, to allow remote supervision of staff loading medications into the dispensing device. All locations where telepharmacy equipment will be placed must be able to be wired for video conferencing connectivity.

Many hospitals already use video conferencing systems and bandwidth requirements should be assessed before implementing telepharmacy services. The concurrent use of multiple video conferencing units within a facility, even with Quality of Service (video packet prioritization) deployed, can cause network congestion if not configured properly.

## **B. Planning Construction**

### 1. Retail Telepharmacies

#### a. Design

After the needs assessment is confirmed, design experts at the drug wholesaler will draw plans. The licensed pharmacist at the central pharmacy site will also assist in this stage of development. Once plans are developed, they should be submitted to the State Board of Pharmacy for review and approval.

b. Fixtures

Drug Store fixtures are available through most drug wholesalers or through companies specializing in these areas. Prices can be bid, or previous projects can be consulted, to determine reasonable prices. Used fixtures can sometimes be obtained through the sale or renovation of a local pharmacy store in the area. Drug fixtures for an average size pharmacy may cost \$20,000 or more.

c. Inventory

Inventory always requires capital. The up front store merchandise can be stocked and ordering done as demand is assessed. Prescription drug inventory can be expensive. Purchases should initially be conservative and based on expected demand. Generally for a rural community pharmacy, prescription drug inventory may cost between \$60,000-80,000 depending on the brands that are stocked. Factors such as frequent deliveries from the drug wholesaler, the ability to move merchandise between the central pharmacy and the remote telepharmacy site, and limiting inventory/potential losses can help control costs. The licensed pharmacist at the central pharmacy, in consultation with area drug wholesalers, will be able to assist with the initial set-up and management of the telepharmacy store merchandise and prescription drug inventory.

Telepharmacy technology is very new, so prices are generally high, but should decline as demand increases. Telephone companies in rural areas seem the most reluctant to lower transmission costs. Transmission costs are often higher when the central pharmacy and the remote site are not being served by the same telephone company. In North Dakota the DSL lines may cost approximately \$250 per month (512 K bandwidth), and T-1 lines are considerably more expensive and may cost up to \$800 per month (1.544

mbps bandwidth). Prices will vary depending on location, competition, demand, and vendor.

d. Information Technology Considerations

i. Computer

A traditional full service pharmacy has a computer system installed with a specially designed pharmacy operations software (many software vendors are currently available on the market including QS-1, Midco Data, PDX, Rx30, IsoRx and others) which assist pharmacists in dispensing prescriptions to patients. This pharmacy operations software performs functions such as establishing a patient medication profile; screening for drug interactions, generating prescription vial labels with patient instructions, and billing third party payers.

In the telepharmacy model, a computer system containing the same pharmacy operations software is located and fully integrated at both the central pharmacy site and remote telepharmacy site. This allows the pharmacist at the central pharmacy to access the patient medication profile at the remote site, and allows the pharmacist to perform a prospective drug utilization review by computer on each prescription before it is dispensed to the patient. This technology set-up also allows the pharmacist the flexibility to work from either location (i.e. the remote telepharmacy or the central pharmacy site) to process the prescription order. This often occurs, as many of these operations will have only one pharmacist on duty at a time. The pharmacist may want to visit the telepharmacy site on some days and work from there, with the technician at the central site performing the role of the telepharmacy technician.

The technology hardware needed is the same for both the central pharmacy and remote telepharmacy sites including a standard PC with

512 Meg of RAM, 18 inch color monitor, read/write CD with DVD, 3.5 disk drive, speakers, microphone/headset, modem, and printer. This computer system costs approximately \$2,000. However, it should be noted that a telepharmacy vendor may dictate the specifications of the PC.. Since the central pharmacy already has a pharmacy computer system, only one additional set-up is needed for the remote telepharmacy site. The cost of the pharmacy operations software may vary depending on the vendor but many can be purchased in the \$5,000-\$7,500 price range.

## ii. Video

This is an important part of the telepharmacy system. The video allows the pharmacist at the central pharmacy site to see the finished prescription, which was prepared by the technician at the remote telepharmacy site. The picture from the digital camera is of sufficient quality to allow the pharmacist to read the prescriber's hand written prescription, the label of the manufacturer's original drug container, the label of the prescription vial handed to the patient, and even zoom in and read the identification code on the individual tablet or capsule. These digital pictures of the prescription processing function can be stored on the computer hard-drive or writeable CD for later recall or they can be printed and filed with the original prescription. This type of documentation provides important quality assurance to validate that the prescription was filled correctly. This prescription validation process is another unique value added feature of telepharmacy operations and is not currently seen or utilized with traditional pharmacy services.

There are several different vendors on the market for video-conferencing. One of our sites began using Microsoft NetMeeting® as its video conferencing system, where the pictures were projected directly onto the pharmacist's computer monitor. This system was a continuous video, which allowed the pharmacist to continuously monitor the technician's

work if they wished. This exceeded the Board of Pharmacy requirements for the telepharmacy rules in allowing constant communication with the technician. However, when the patient education counseling was performed by the pharmacist, the picture was of poor quality. In addition, patients did not feel comfortable talking with the pharmacist on a computer monitor. This video conferencing system was later replaced by a Polycom-FX H.323 Viewstation with a 20" Sony WEGA television monitor which produced a higher quality picture to allow pharmacists to effectively counsel patients on proper use of their medications. This Polycom system costs approximately \$6,500. Two video conferencing set-ups were needed, one for the central pharmacy and one for the remote telepharmacy site.

Polycom has several videoconferencing systems to choose from. The Polycom – SP, FX, and VSX models are just a few of the choices. The SP model is the most basic and least expensive, and the other models have more features which allows for additional connections to a VCR or other equipment. The SP model allows for only point to point videoconferencing. The Polycom-FX and VSX models are more expensive but have the greatest features and capabilities including the ability to add up to 4 sites to be connected simultaneously. Depending on the features for videoconferencing equipment can range between \$3,500 – \$15,000 or more. Any of these units will work in delivering telepharmacy services and there are other manufacturers to consider such as Tandberg and Sony.

Another remote site initially used a hand held digital camera for their pictures and then transmitted them by setting the camera in a cradle device and downloading them into the telepharmacy system. This provided good quality but proved to be too slow to be practical. This was later replaced by a fully integrated live or real time document camera which is capable of capturing pictures for instant viewing through the

telepharmacy system by the licensed pharmacist at the central pharmacy site. This later set-up proved to be far more efficient and convenient.

In addition, it should be recognized that the audio/video conferencing system can share the same network connectivity as the the pharmacy operations software. This is the most cost effective way of providing connectivity for both applications. However, if the network is interrupted for any reason, both systems will cease to function until the network problem is resolved. **Since prescriptions are being processed continuously throughout the day it is imperative that the prescription processing system remain on-line. Therefore, it is highly recommended that a parallel network be developed, so that the prescription processing system can remain on-line in the event of a video conferencing network failure (e.g., separate DSL connection, dial-up modem connection, etc). The importance of network redundancy for telepharmacy can not be overstated.**

### iii. Transmission

Both the pharmacy computer data and the video conferencing signal can be transmitted over the Internet using DSL lines at 512 K bandwidth. However, because DSL typically operates with different upload and download speeds, the quality of service cannot be guaranteed. Unfortunately, there is no way to know in advance whether the transmission will be acceptable or not. On occasion, when the service has been disrupted between sites preventing the pharmacist from using the video conferencing system, the pharmacist calls the remote site by telephone and the patient consultation is done by phone.

Dedicated T-1 lines would be the ideal transmission mode for delivering telepharmacy services and would eliminate the problem of service distortion or disruption from heavy Internet use. However, in North Dakota

the high cost prohibits their use for retail telepharmacy at this time, unless an existing dedicated T1 network is being used. As demand for telepharmacy services increases, the cost of dedicated T-1 lines may become less of a barrier. Additionally, one site in North Dakota recently negotiated with its local telephone company to purchase a fraction of a T-1 line (512 K bandwidth) for only \$150 per month for both connections (central and remote site). This was \$100 less than what most DSL lines cost. So it is wise to shop around for best prices on both technology and transmission.

Plain Old Telephone Service (POTS) lines connected via a 56 K modem can also be used for transmitting data when rural communities do not have the technology infrastructure in place to support DSL or T-1 lines. However, using POTS lines causes a significant slow down in the speed with which the pharmacist can process prescription orders because modem placed long distance calls are needed each time communication between the sites is desired. This significantly reduces the operational efficiency of the pharmacist and pharmacy services being offered.

#### iv. Security of Information – HIPAA Compliance

Since telepharmacies transmit personal and health related information on patients over the Internet via DSL lines, security of information becomes a concern. New federal requirements of the Health Insurance Portability and Accountability Act (HIPAA) of 1996 have established standards for privacy and security of individually identifiable health information regarding electronically transmitted information on patients. It must be stressed that all pharmacy systems including telepharmacy operations must be in full compliance with the new federal HIPAA standards. Care must be taken to ensure the privacy and security of all electronically transmitted health information on patients.

Telepharmacy systems can be secured by installing a VPN (Virtual Private Network)/firewall, a small piece of equipment about the size of a DVD player, at both the central pharmacy and remote telepharmacy sites. The VPN at each site encrypts all information between endpoints and that protects the privacy of the information over the Internet. Some older Polycom videoconferencing systems require the addition of a VPN to make them HIPAA compliant when operated over the commodity Internet. However Tandberg and the newer Polycom units can be deployed with AES encryption which would make them compliant with HIPAA without the need for additional VPN hardware, and when operated over the public Internet. If dedicated T-1 lines are used, they are already secured for privacy by the fact that they do not typically link to the Internet. A VPN/firewall system costs approximately \$600. Two units are needed, one for the central pharmacy and one for the remote telepharmacy site.

In summary, patient confidentiality and HIPAA compliance are assured at all telepharmacy operations with DSL/VPN systems using encrypted information for all information transmitted over the Internet. Business Associate Agreements should be obtained for all contractors who handle transmission of patient information, and for hardware and software suppliers who may have access to patient information. Patient Consent Agreements, approved by the Institutional Review Board for the Protection of Human Research Subjects at the University are needed for the collection of any patient specific data for evaluating the project.

## 2. Hospital Telepharmacies

The majority of the construction, cost and technology issues cited above for retail telepharmacy programs are the same for rural telepharmacy hospital programs. However, there are some distinct differences. Because hospital telepharmacy programs are implemented in facilities with existing pharmacies, necessary fixtures and inventory should already be in place.



One caveat is that rural telepharmacy hospital programs require the use of unit dose packaging. Nurses only deal with unit doses of medication that they load into or dispense from the automated dispensing devices. The hospitals will either have to begin purchasing medications in unit dose form, or will have to arrange for a pharmacy technician or a local retail pharmacist to repackage medications into unit dose form.

Redesign of existing rooms should not be necessary, provided that adequate space is available for the videoconferencing and automated dispensing equipment.

Because of the need for sharing patient information, the rural and the urban hospitals participating in a telepharmacy program will either need to utilize the same hospital information system or to establish an interface between the systems that they operate. This will allow the urban hospital pharmacist access to the medical records for the patients in the rural facility, a necessary step in verifying the appropriateness of the prescription.

### 3. Central Pharmacy

Although the majority of the construction plans for telepharmacy services generally focuses on the remote site, the central pharmacy also often requires some remodeling. Special consideration should be given for ensuring that sufficient space is allocated for a private patient consultation room to accommodate the patient education counseling equipment. Careful planning and placement of the telepharmacy technology is important and can significantly assist the pharmacist in running a smooth and efficient pharmacy operation. The pharmacist must have quick and convenient access to all necessary telepharmacy equipment including the pharmacy computer system, document camera, and video conferencing system to properly and efficiently serve the remote site. The pharmacist must have the ability to go back and forth between checking prescriptions in the traditional pharmacy,

while monitoring, checking, and counseling via the telepharmacy connections. If a central pharmacy has multiple remote telepharmacy sites which it serves, it may be necessary to have a full-time pharmacist on staff whose job is dedicated to verifying prescription orders and counseling patients at the remote telepharmacy sites.

A central hospital pharmacy that is taking on a telepharmacy program needs to consider expanding its staff to support multiple remote sites. This is especially important in assuring that the remote sites have 24/7 coverage. Additional space and equipment may be necessary in the central pharmacy to support these additional personnel.

### **C. Personnel Considerations**

#### **1. Pharmacy Technician**

The responsibilities of the pharmacy technician at the remote telepharmacy site include maintaining the prescription drug inventory and completing all aspects of the drug dispensing process. Activities include but are not limited to: (a) obtaining the prescriber's written prescription order from the patient or taking the order from the prescriber by phone; (b) computer drug order entry; (c) product selection, preparation, packaging and labeling; (d) third party billing; (e) operating the telepharmacy technology to connect the audio and video link to the licensed pharmacist at the central pharmacy site; (f) providing digital pictures of: (1) the written prescription order by the prescriber, (2) the manufacturer's original drug container, (3) the actual tablet or capsule for proper tablet/capsule identification, and (4) the technician generated prescription label for the patient; (g) obtaining the final check of the dispensed product from the licensed pharmacist; and (h) assisting the patient in the use of the telepharmacy technology for the pharmacist

education counseling. A step by step protocol is provided for processing new prescriptions and prescription refills.

The pharmacy technician is, perhaps, the most important element in the telepharmacy program. Without well trained pharmacy technicians, in which the profession of pharmacy has confidence, telepharmacy will have no chance of surviving in any state. The pharmacist is ultimately responsible and liable for what happens to the patients receiving the service. In addition, the prescribers who are expected to communicate prescriptions to the pharmacy technician must be comfortable and confident in their abilities, to transcribe the prescription correctly. The public must also be comfortable and establish trust in working with the pharmacy technician, as their personal contact at the remote telepharmacy site.

Since the pharmacist in this model is delegating a significant amount of responsibly to the pharmacy technician at the remote telepharmacy site, it is critical that the pharmacy technician has appropriate qualifications and training to handle the job. For this reason, the North Dakota Board of Pharmacy has established higher standards for pharmacy technicians working in remote telepharmacy sites than those established for technicians working in traditional pharmacies where the licensed pharmacist is physically present in the store. To work in a remote telepharmacy site, pharmacy technicians are required to be registered by the Board of Pharmacy and have at least one year of work experience in prescription processing as a North Dakota registered pharmacy technician. The pharmacy technician must also have graduated from an American Society of Health Systems Pharmacists (ASHP) accredited program or have received other equivalent training which demonstrates knowledge and experience in preparation of prescriptions for dispensing and working with patients. Reciprocity of

pharmacy technicians from other states requires Pharmacy Technician Certification Board Examination (PTCB certification), as well. Technician PTCB certification is voluntary in North Dakota. North Dakota requirements for a pharmacy technician exceed PTCB standards. All North Dakota registered pharmacy technicians are required to complete 20 hours of continuing education every two years.

During the development of the telepharmacy rule in North Dakota, some thought the pharmacy technician should have an associate of applied science degree from an ASHP accredited school to qualify for work in a remote telepharmacy site. However, such criteria had the potential to create an environment where recruiting a technician would have been as difficult as recruiting a pharmacist to a remote site. In negotiations it was decided to allow a graduate of an ASHP accredited program or equivalent, with one year of experience, to serve as a remote pharmacy technician. This is a high standard in itself, but has served to provide the necessary confidence of the pharmacists, the prescribers, the public, and the profession. Recruitment of pharmacy technicians is still a challenge for the remote telepharmacy sites. In many cases, hourly rates of up to \$15.00 per hour or more were needed to attract qualified technicians to these sites. This rate is typically \$5-7 per hour more than what urban markets in North Dakota pay for pharmacy technicians.

In situations where a qualified pharmacy technician cannot be recruited to relocate to a remote rural telepharmacy community, an alternative may be to identify someone who already lives in the targeted rural community and deliver an established pharmacy technician training program to them via distance education. This training must take place at the central pharmacy site. The North Dakota State College of Science in Wahpeton North Dakota has an ASHP accredited pharmacist-assisted technician training module program, which can be completed on the job, at the central pharmacy site. After completion of the program and one

year of experience, the registered technician is ready to work at the remote telepharmacy site. Since pharmacy technicians at the remote telepharmacy sites are without the services of a pharmacist at the site, it is extremely important, and cannot be stressed enough, that these individuals need to be properly trained for performing their duties in delivering safe and effective telepharmacy services to rural residents. Training programs used for telepharmacy technicians should be reviewed and approved by the State Board of Pharmacy prior to their implementation.

In the rural telepharmacy hospital program, nurses administer the physician-ordered medications after authorization by a licensed pharmacist at the central hospital pharmacy. In Washington, this is already within the nurses' scope of practice. Additional training and certification is necessary for nurses who restock the automated dispensing devices. The Washington State Board of Pharmacy has permitted nurses to take this on, under the video supervision of licensed pharmacists, provided that the nurses obtain pharmacy technician certification. The Washington program includes training for nurses to assist them in obtaining this certification and filling this role.

## 2. Licensed Pharmacist

The primary responsibilities of the pharmacist at the central pharmacy site are to provide professional consultative services to the remote telepharmacy site for all prescriptions dispensed at the remote site. These activities include but are not limited to: (a) performing a final check of the prescription prepared by the technician; (b) performing a complete drug utilization review on the patient's medication profile; and (c) performing the mandatory patient education counseling. The pharmacist must remain responsible for all professional aspects of the patient's care, even though greatly assisted by the pharmacy technician.

It is necessary for the pharmacist at the central pharmacy site to have experience in working with pharmacy technicians. The pharmacy technician will be managing the inventory at the remote site, so the pharmacist must have complete confidence and trust in the pharmacy technician's abilities. The pharmacy technician will be preparing the complete prescription for the final check by the licensed pharmacist. Once the prescription is verified by the pharmacist, the pharmacy technician must convince the patient to enter the counseling room, sit down before the television monitor, and be counseled by the pharmacist. This requires an ability to work with people. The personal confidence of the pharmacy technician is very important. They must perform all required tasks, while still feeling comfortable to ask questions whenever verification is needed. A pharmacy technician who pretends he/she knows everything and can do everything can be very dangerous. It must be stressed that the pharmacy technician must rely upon and be dependent on the pharmacist for all non-technical professional aspects of pharmacy practice.

Licensed pharmacists at central pharmacy sites have been very excited and quite positive about delivering telepharmacy services to another rural community. Pharmacists are enjoying the benefits of telepharmacy services such as: the ability to expand their businesses by accessing additional patients; the additional revenue from increased prescription sales (telepharmacy has increased prescription sales in the combined operation by as much as 40-50% in several locations); allowing pharmacists in rural practices to take a day off or a vacation by having someone cover their store from another location; and allowing expansion of pharmacy store hours on weekends without having to add additional staff. Pharmacists are also optimistic that telepharmacy will help enhance their current business environment and make their store

more attractive, which will ultimately increase their chances of selling the pharmacy, when they are ready to retire.

Pharmacists at central pharmacy sites, however, have expressed concern regarding the extra workload they have experienced resulting from delivering telepharmacy services. This workload problem appears to be significant, especially when central pharmacies have more than one remote site to manage. Telepharmacy rules in North Dakota allow a pharmacist to manage up to four remote telepharmacy sites. Due to the increased workload, one of the central pharmacy sites (which manages two remote telepharmacy sites) has hired an additional pharmacist (0.8 FTE) to assist with the extra workload. The decision whether or not to add more pharmacists to the workforce is left up to the licensed pharmacist store owner at the central pharmacy site who is ultimately responsible and accountable to the Board of Pharmacy for ensuring the safe practices.

Similarly, urban hospitals taking on a telepharmacy program need to assure adequate staffing. Since urban hospital pharmacies are already operating on a 24/7 basis, new swing-shift staff should not be necessary. However, if the urban hospital is providing full-time pharmacy services to multiple rural sites, additional staff will likely be needed.

#### **D. Patient Considerations**

It is important that patients are comfortable with the telepharmacy technology prior to receiving services. Consideration should be given to formally marketing the telepharmacy concept to the public prior to implementing services. Proper information and education of the patients and public can assist in alleviating any questions or concerns regarding how it works and what it looks like, including the similarities and differences between telepharmacy services and traditional pharmacy services. This

can help the patients and public feel more comfortable and willing to use the services. Special attention and consideration should be given to orientation and education of senior citizens who have not been exposed to, or do not have, extensive experience with technology. Once they have been walked through the system, shown how things work, and have a chance to use the equipment, they generally accept this high tech approach to delivering pharmacy services. Headphones can be helpful for those seniors who have hearing impairments and printed material can assist those who have difficulty in seeing the television monitor. On occasion a patient has been reluctant to talk to the pharmacist over the television monitor and in these situations the pharmacist calls the patient and discusses their medications with them via telephone.

Patient acceptance of telepharmacy services has been very good. Patients living in remote rural communities that have not had pharmacy services for sometime are generally the most enthusiastic and accepting of the telepharmacy technology. Patients are generally more hesitant to use this technology in rural communities that have had traditional pharmacy services and where telepharmacy is deployed to retain these services. However, once patients get their first exposure to telepharmacy, they are generally quite accepting of this approach to delivering pharmacy services. Patients also appear to be more hesitant in communicating with the pharmacist through a computer monitor than they are through a standard television, probably because they are familiar with and exposed to television at home. Patients unwillingness to participate in patient education counseling via telepharmacy services is not any different than that observed with traditional pharmacy practice. With either telepharmacy or traditional pharmacy service, luring the patient into the consultation room for their first counseling session has always presented a challenge for practicing pharmacists. Patient resistance to being counseled appears to play more of a factor than their inherent fear of using technology. Pharmacists need to work on



changing patient expectations and behaviors related to mandatory patient education counseling so that patients learn to expect it as a routine part of pharmacy practice regardless of the mode of delivery.

Since patients entering remote telepharmacy sites do not have a pharmacist at the site, we must stress the importance of the patient interaction with the pharmacist prior to leaving the pharmacy. In North Dakota as an additional quality assurance measure, all patients at remote telepharmacy sites are required to speak to the pharmacist prior to leaving the pharmacy with their prescriptions to ensure that they know and understand the proper use of their medications. Pharmacists at the central pharmacy site must perform patient education counseling on all telepharmacy patients at the remote site. This is a part of the rules and regulations established by the State Board of Pharmacy for telepharmacy operations in North Dakota. This patient consultation requirement exceeds the standards set for traditional pharmacy services by federal law (i.e., OBRA'90) which requires a pharmacist to offer education counseling to the patient, but the patient can decline. In telepharmacy operations, the patient must be counseled by the pharmacist or the patient does not receive their medications at the remote site. This is another value added feature of telepharmacy services, not currently seen or practiced in traditional pharmacy settings.

In the rural telepharmacy hospital program, patients have access to their physicians and nurses, but should be encouraged to consult with the licensed pharmacist via videoconferencing if they need additional information.

#### **E. Quality Assurance**

The licensed pharmacist at the central pharmacy site should establish written policies and procedures related to the delivery of telepharmacy services to

ensure the safe and effective distribution of pharmaceutical products and patient care for the central pharmacy and remote telepharmacy sites.

The licensed pharmacist at the central pharmacy site should also conduct ongoing review of incident reports and outcomes related to the delivery of telepharmacy services and keep records of appropriate corrective action taken when necessary, to ensure that there is no abnormal frequency or trends of errors occurring in dispensing drugs or devices to patients.

The licensed pharmacist at the central pharmacy site is responsible for the care of the patient and the final product prepared by the pharmacy technician at both the central pharmacy and the remote telepharmacy sites. Regular visits to the remote telepharmacy site by the licensed pharmacist at the central pharmacy site are required and should be at least monthly.

The State Board of Pharmacy should make periodic inspections of the central pharmacy and remote telepharmacy sites to ensure their compliance with all state and federal laws and rules related to the practice of pharmacy.

In North Dakota, the North Dakota State University College of Pharmacy is conducting research, relative to patient satisfaction and utilization of telepharmacy services by the community. These survey tools are available and can be adapted for use by others.

#### **IV. Useful References**

Telepharmacy Rules. North Dakota Century Code 61-02-08. North Dakota State Board of Pharmacy, Rules and Regulations for Practicing Pharmacy, <http://www.nodakpharmacy.com/NDBP/law/law-01-31-03.pdf>

Peterson CD, Anderson HC. The North Dakota Telepharmacy Project: Restoring and Retaining Pharmacy Services in Rural Communities. *J Pharm Technol.* 2004 Jan-Feb; 20:28-39.

Lordan D, Vorhees N, Richards C. Telepharmacy offers hope for rural hospitals. National pharmacist shortage prompts innovative approach to hospital-based services in Washington state. *Telemed Today*. 2002 Oct-Nov; 9(3): 13-15.

Keeys CA, Dandurand K, Harris J, Gbadamosi L, Vincent J, Jackson-Tyger B, King J. Providing nighttime pharmaceutical services through telepharmacy. *Am J Health Syst Pharm*. 2002 Apr 15; 59(8):716-21.

Bynum A, Hopkins D, Thomas A, Copeland N, Irwin C. The effect of telepharmacy counseling on metered-dose inhaler technique among adolescents with asthma in rural Arkansas. *Telemed J E Health*. 2001 Fall; 7(3): 207-17.

American Society for Health-System Pharmacists. Focus group on telepharmacy. *Am J Health Syst Pharm*. 2001 Jan 15; 58(2): 167-9.

Kate, D. Late-night telepharmacy service an asset to hospitals. *Drug Topics*. 2001; 16:22.

Thigpen AR. The evolution of telepharmacy: a paradigm shift. *J Healthc Inf Manag*. 1999 Winter; 13(4): 89-94.

Angaran DM. Telemedicine and telepharmacy: current status and future implications. *Am J Health Syst Pharm*. 1999 Jul 15; 56(14): 1405-26.

Pharmacy Automation Online. Automated Dispensing Technologies: Directory of Vendors. <http://www.pharmacyautomation.com/vendors.html>

## **V. Sample Protocols** (next page)

**STEP BY STEP PROTOCOL FOR  
PROCESSING NEW PRESCRIPTIONS  
AT REMOTE TELEPHARMACY SITE**

New Prescription is received by Pharmacy Technician from:

Patient  
Written prescription

Prescriber  
phone/fax/computer

[Some pharmacists prefer the prescription be faxed to the central pharmacy for entry.]

[Some pharmacists prefer calls to come to the central pharmacy]

[In North Dakota it is permitted for the pharmacy technician to perform these functions if allowed by the pharmacist]

IF PATIENT IS KNOWN  
Verify Insurance  
Any new allergies

IF PATIENT IS NOT KNOWN  
Get demographic/Allergy info  
Insurance / Family history  
Disease status

Verify prescription has all required elements:

Non-controlled substance  
NDAC 61-04-06-02

controlled substance  
61-04-06-03

Is prescription readable and understandable?  
A N Y Questions - contact pharmacist

Enter prescription into the computer patient profile  
Pharmacist performs drug utilization review:

No Allergies or Drug-Drug/  
Drug-Disease Interactions:

Allergies Drug-Drug/  
Drug-Disease Interactions:  
Contact pharmacist for verification

Proceed to select correct product  
Prepare prescription for dispensing & label proper use instructions  
Bill through insurance- Clear any 3<sup>rd</sup> party problems (early refill etc.)  
Final check performed by pharmacist  
Seat patient in consultation room  
Connect patient to pharmacist via audio/video link  
Place filled prescription on table in front of patient  
Pharmacist performs patient education counseling - Dispensing takes place here  
Bag /Package prescription including written product information (PPI's)  
Complete financial transaction

Thank you / come back soon

**STEP BY STEP PROTOCOL FOR  
PROCESSING REFILL PRESCRIPTIONS  
AT REMOTE TELEPHARMACY SITE**

Patient requests refill

No Insurance changes ?

Pharmacy Technician processes prescription through computer

No refills remaining

Contact prescriber for refill request

Any drug alert:

Notify the pharmacist

Prepare prescription for dispensing

When ready for final check – contact pharmacist

Final check performed by pharmacist

Invite patient to talk to the pharmacist (not required for a refill)

If patient accepts:

Seat patient in consultation room

Connect patient to pharmacist via audio/video link

Place filled prescription on table in front of patient

Pharmacist performs patient education counseling - Dispensing takes place here

Bag /Package prescription including written product information (PPI's)

Complete financial transaction

Thank you / come back soon

## Chapter Eleven

---

### Rehabilitation

**Author:** Cynthia Scheideman-Miller, MHA, Integris Health

#### **Contributing Editors:**

Beth Hudnall Stamm, PhD, Idaho State University

Donal Lauderdale, National Rehabilitation Hospital

Micha Post, Integris Health

Nancy Willis, St. Alexius Medical Center

Pamela Forducey, PhD, Integris Health

Russell C.Spearman, MEd, Idaho State University

Steve Dawson, PT-NDT, Integris Jim Thorpe Rehabilitation Center

Wanda Weekly, Mid-Nebraska Telemedicine Network

#### **I. Introduction**

The purpose of this document is to outline key milestones and considerations for creating and sustaining a telerehabilitation program. This document was drawn from the collective experiences of over 4,500 telerehabilitation encounters from programs at INTEGRIS Health (Oklahoma); Good Samaritan Hospital (Nebraska); Idaho State University (Idaho); National Rehabilitation Hospital (Washington, D.C.); and St. Alexius/Northland Health Care Alliance (North Dakota).

#### **II. Background**

**Rehabilitation** is the process of restoring someone to a state of health or useful activity through training, therapy, and guidance.

**Telerehabilitation** is the clinical application of consultative, preventative, diagnostic and therapeutic therapy via two-way interactive audiovisual linkage.

Telerehabilitation is an inclusive term for a variety of disciplines and is used with a large diversity of diagnoses. Disciplines associated with long-term health care includes, but is not exclusive to:

- speech-language pathology (SLP)
- auditory/verbal therapy
- physical therapy (PT)
- occupational therapy (OT)
- vocational rehabilitation
- neuropsychology
- pain management,
- wound care
- physiatry
- pharmacy consultation

Telerehabilitation may be used for orthopedic and developmental applications, or following neurological insult such as stroke, acquired brain injury or spinal cord injury. Telerehabilitation is used to reach patients and their caregivers in a variety of sites including hospitals, nursing homes, clinics, private residences and schools. It is used for direct patient intervention as well as peer consultation and mentoring. Nineteen different programs surveyed by Office for the Advancement of Telehealth (OAT) in 2001 included some kind of telerehabilitation activity at their site. Most common applications were speech language pathology and splinting instructions.

There are three basic types of telerehabilitation sessions using interactive video:

1. Direct patient intervention: the therapist either works directly with the patient, or guides the remote therapist or caregiver for cueing, props, etc. The patient may be alone, with a caregiver present, with an aide present but not participating, or with a local therapist being guided by the remote therapist.
2. Mentoring (patient present): management strategies, activity selection based on grading (patient status/abilities based on standard categories), handling training and development are discussed with the therapist while the patient is present. This often includes the therapist actually implementing the suggested therapy while the remote therapist is there for guidance.

3. Consultation (patient not present): concepts and principles discussion, session analysis / feedback; and planning. This usually follows a patient session and is conducted between the two therapists. (*Dawson, et al Physical Therapy Case Study Reports 2000*)

### **III. Step-By-Step Guide To Creating A Successful Telerehabilitation Program**

#### **A. Creating a Telehealth Program:**

Basic step-by-step guidance to develop a telemedicine program has already been reviewed in chapters one and two. However, rehabilitation has its own unique characteristics and challenges that need to be considered.

#### **B. Planning the Program to Meet the Needs of the Underserved**

When looking at potential markets for rehabilitation, ask the question “ how specialized are the services to be offered?” If the provider is a pediatric physical therapist that specializes in therapy following neurological insult, service potential will be geographically dispersed, with low volume and intermittent demand. Speech language pathology to schoolchildren, on the other hand, has a high potential volume with great probability for repeated business. This is due to the large number of children, difficulty for some school districts to secure a speech therapist, and federal mandates to supply services. Charges to the school may be less per session than an outpatient therapy session; but the volume and steady income stream compensates for the difference. The activity, revenue and costs are easier to forecast, making the latter program more likely to be sustainable. It is wise to also check to see if there are technical, legal, regulatory, or local perceptions that might prevent the implementation of teletherapy services.

Creating a tentative business plan is the best way to begin any program, but setting up a successful program in telerehabilitation has an extra challenge. It is often difficult for payers and providers to envision how rehabilitation could work using remote or long-distance video conferencing. It is especially hard to imagine how something that traditionally requires therapist touch can use caregiver’s hands as substitutes for the therapist’s hands. Third party payers and others need to be educated on telerehabilitation by demonstration of equipment and how it works, as well as through



examples of outcomes studies and other telerehabilitation programs. Even if legislation is already in place regarding reimbursement, it is easier to educate third party payers prior to implementing the program, rather than correct a misconception after implementing the program. If starting a program from the beginning, it would be advisable to start with a discipline such as speech language pathology, where touch is less important and therefore easier for clients to understand its feasibility.

**Potential markets:**

Markets need to be based on sufficient demand for an identified need. For example, a large demand for speech language pathology has been created for schools through federal mandates. On the other hand, speech language pathology following stroke may be needed, but lack of third-party reimbursement for telespeech language pathology greatly decreases the demand. The larger the demand, the better the chance for the program to survive and thrive.

Telerehabilitation clients can be found in a variety of settings. The clients may be individuals scattered over a large geographical area or concentrated at one site such as a local hospital that doesn't have a therapist on staff. Marketing approaches vary by target group, but all need to be built on gaining the trust and buy-in by providers and other stakeholders.

Patients may be identified as candidates for rehabilitation while still in the hospital or through agencies such as the Department of Rehabilitative Services. In addition to direct demonstrations, CME/CEU courses, and brochures aimed at healthcare providers, it is helpful to get patients to request the services. Marketing of telerehabilitation as an option can be done directly to the patients and caregivers by working through special interest groups, such as the state Brain Injury and Rural Health Associations. Case managers must be included in the education process since they are critical in the promotion of telerehabilitation. There is often a turnover of case managers, so an on-going education/re-education process needs to be included in the plan.

Those patients/clients grouped by specific life circumstances or age - so-called “captive” populations - should be considered (Kronenfeld, et al), especially if a higher volume is needed to get a telerehabilitation program off to a strong start. Captive populations can include prisons, schools, and long-term facilities. Schools are federally mandated under the Individuals with Disabilities Education Act to supply special services for students with disabilities (Federal Register Vol.64, No. 121, June 24, 1999). This can be problematic for administrators, especially in more remote rural areas that have a small school population. It is more cost effective for their students to receive services remotely than pay for travel expenses for a visiting provider. It also can be beneficial to the pathologist. One speech pathologist, for example, can serve several schools having five to fifteen students, and not lose productivity time to travel (*Clark, Scheideman-Miller, Advance 1999*).

There are different ways to approach rural communities about telerehabilitation. The schools can be approached through direct mailings; booths at conferences; building on current relationships; or referrals from current clients. The latter has the greatest chance of success, simply because building trust is important to starting a service in a rural area and personal referrals accelerate that trust. When dealing with schools, it is suggested to meet and demonstrate the equipment to the special education director, administrator, and (in some cases where telerehabilitation is being considered to supplement current therapy services) the school speech, physical or occupational therapist. Once their approval is secured, a presentation should be made to the school board for the next level of approval. Finally, once the board approval is secured, a special demonstration of the equipment at the school’s open house plus newspaper coverage is suggested. This lets everyone in the community know about the new service and how it works. It also helps lessen the fears of the occasional parent who might feel that their child is given inferior care if it is delivered over telemedicine.

When dealing with rural healthcare providers and administrators, it is imperative to build positive relationships and a level of trust. It is helpful if the remote site already has used the consulting facility for other services. This will build on that relationship. Therapists are sometimes territorial and protective of their patients. It is best to emphasize that

telerehabilitation is meant to enhance, not replace, local services. When asked by the family or patient for specialized telerehabilitation services, the specialist should contact the local therapist and include them in the planning process. If appropriate, part of this process should be the transition of services to the local therapist. This not only helps the local therapist provide quality care to their patients; it helps reassure the local therapist that the remote therapist is not intending to take away their patients.

### **Estimating Costs:**

Cost analysis varies by application and patient. Example: Cost analysis for school telespeech language pathology delivered via broad bandwidth should include:

- Average therapy session time (in hours) per student per week (assume 34 to 36 weeks in a school year).
- Non-intervention time (in hours) needed per consult for related paperwork.
- Average hourly payment to provider for consultation (this currently ranges from \$30 to \$55 per hour nationally according to input from the various contributors).
- Transportation cost for Speech Pathologist (Individual Educational Planning testing needs to be done at the school) (The federal allowable rate is a good guide – currently 0.375/mile).
- Hourly cost of telemedicine broadcasts @ \$/month / hours per month used for telemedicine services (The same line used for distance learning can usually also be used for teletherapy services, which decreases the costs to the schools. In Oklahoma, the line leases on the state telecommunications backbone cost \$550/month for schools and \$850/month for hospitals.).
- Hourly cost of maintenance support needed for each hour of consultation (the cost calculated for INTEGRIS based on salary and average technical assistance was \$54.57/week. This would have to be divided by the number of session hours per week.).
- Hourly cost of technical support needed for each hour of consultation (this amount tends to be small when therapists use the equipment frequently – they become quite adept at connecting with the remote site and simple trouble shooting.).

- How much additional hub overhead is generated for each consult due to billing, scheduling, and record-keeping (This can vary depending on the payment arrangement with the school. Flat fee billing each month requires approximately 1 hour/ month office staff time, while billing by the hour or by the number of students seen requires approximately 20 minutes/student/month office staff time plus 1 hour/student/month of therapist time.).
- In the case of the school costs, a teacher's aide or therapy assistant will be present for the sessions, which will add to the school's costs. (The teacher's aide is usually near minimum wage. This will vary by school and what other duties the aide has.)

It is important also to know the current market trends. Standard hourly therapy charges may not be competitive with standard charges at the remote site. Charges may have to be reduced to align with what the school might pay an on-site employee in order to be competitive in that region of the country. Also, a sliding fee schedule may be developed based on average salaries for an area or individual incomes. This may require an increase in session volume to break-even.

Telerehabilitation using videophones or computer linkages are usually used with individual patients and have slightly different variable costs. Lower bandwidth options generally cost less than broadband lines due to lower broadcast and technology charges. A POTS line can run about \$30/month for basic service. If the organization is large enough to have WATTS lines little to no additional cost will be incurred for a therapist's videophone to be added. Broadband lines could be less costly than low bandwidth lines if reimbursement through the Universal Service Fund lowers the cost of telecommunications significantly enough to be considered in a cost evaluation.

### **Revenue:**

Revenue streams are important for the organization and therapists, and often for the remote sites as well. Schools, for example, get state funding for the Individual Education Plan (IEP) services. If the state Medicaid program pays the schools for their students' therapies, the school may receive additional funding. The teletherapist fills out standard Medicaid documentation for each student that receives services. It is important to

consult with the Medicaid program in the state to affirm that they reimburse for telemedicine, and the preferred method of billing. The school may be the designated provider that bills, or Medicaid may have the therapist bill directly for services instead of the school being involved in billing. Program education and billing issues need to be resolved prior to the service being delivered. The final step is for a contract to be written with the school to clearly define the costs and responsibilities for both the school and the healthcare provider.

*When the first telespeech project started in Oklahoma, several visits were made to the Medicaid agency prior to beginning the project. This helped to ensure several people at the agency knew what was being proposed, that they were comfortable that the students were actually receiving therapy, and that the billing process was administered in the fashion they wanted. The agency dictated that the school was the provider and made the actual application for funds from Medicaid. The school paid directly for the therapist, and the therapist provided the necessary paperwork for the school to send to Medicaid for reimbursement.*

### **Potential funding sources:**

Revenue can be generated through reimbursement for services through third party payers, or through contractual arrangements

- Contracts to schools, Indian Health Services
- Fee for service to Dept. of Rehabilitative Services; workman compensation
- Reimbursement from third party payers
- Long-term care authority
- Self pay

It should be noted that schools in some states may accrue revenues if the students receive needed therapy at the school because they are keeping the student on campus. This counts towards the attendance funding formulas.

Cost savings can be documented through reduced provider travel and increased productivity time. This is especially applicable when services are rendered to increase efficiency or for consultation that is not usually reimbursed.

Indirect cost savings may include reduced length of stay or prevented emergency department admissions because of early intervention. This applies more to neurological insult than orthopedic cases.

*One example of an indirect cost savings occurred at the Shepherd Center in Georgia. An occupational therapist (OT) conducted a home assessment remotely with a patient with a spinal cord injury to determine the cause of a recurring wound that had already required surgery. The OT discovered that when the patient transferred from the wheelchair to the toilet, they slid over a rough area on the chair, catching the skin and caused the area to be re-injured. A piece of leather was placed on the chair's protuberance, allowing the patient to make a smooth transfer and protect the leg from harm. This simple solution allowed the wound to heal, avoiding another expensive surgery.*

Worker's compensation or self-insured industries:

PT/OT travel and lodging often paid for rural workman compensation recipients – sometimes for weeks at a time. Telerehabilitation can save insurance companies a considerable amount of money for such non-medical expenses.

**Program Evaluation:**

Program activities can be tracked in a variety of ways including:

- Utilization of equipment (number and type of consults)
- Travel costs saved by provider
- Travel costs saved by patient
- Consumer and provider satisfaction
- Clinical/functional outcomes
- Professional burden
- Caregiver burden

**Table A: Typical Standardized Evaluation Instruments**

<b>Standardized Outcome</b>	<b>Outcome measured</b>	<b>Discipline</b>
Beck Depression	Clinical	All
Functional Independence Measure (FIM)	Clinical/Functional	All
Quadriplegic Index of Function (QIF)	Functional	OT
Motor Activity Log (MAL)	Clinical/ Functional	OT
Canadian Occupational Performance Measure (COPM)	Functional/ Quality of Life	OT
National Outcomes Measurement System (NOMS)	Clinical	SLP
Berg Balance Assessment	Clinical	PT
Timed Up and Go	Clinical/functional	PT
SF 12	Health status	All
State Trait Anxiety Scale	Clinical	All
Professional Quality of Life	Professional Burden	All

Single measurement suggestions:

- Depression
- Community reintegration
- Return of functional status

Professional burden:

People who work in “helping professions” experience both positive and negative effects from their work. Positive responses are due largely to helping, specifically altruism and the pure enjoyment of believing one can make a difference. An example of a negative response, on the other hand, might occur in a rural school SLP who is expected to serve a student with a complex condition such as cleft palate or cerebral palsy, but lacks experience related to this condition nor has access of peers to confer with. This in turn can result in frustration and feelings of isolation for the pathologist.

Positive and negative effects collectively are referred to as professional quality of life (Stamm, 2003), which include compassion satisfaction, burnout and even secondary

traumatic stress. Most are familiar with the concept of burnout, which is a gradual wearing down of one's professional resources, but when the negative effects include real fear in response to helping those who have been traumatized, Secondary Traumatic Stress (STS) can develop and may have symptoms similar to Posttraumatic Stress Disorder (PTSD).

The ProQOL, the Professional Quality of Life Scale: Compassion Satisfaction and Fatigue Subscales: R-III is a measure created to assess quality of life and traumatic stress symptoms (<http://www.isu.edu/~bhstamm/tests.htm>) that measures the negative effects of care giving including traumatic stress symptoms, also called compassion fatigue, and compassion satisfaction. The 30-item ProQOL, which takes about 5-10 minutes to administer, is a revision of the longer 66-item Compassion Satisfaction and Fatigue Scale (Figley & Stamm, 1996). The measure is available in multiple languages. The latest version of the scale, references and psychometric information may be found at [www.isu.edu/~bhstamm](http://www.isu.edu/~bhstamm).

Telehealth can be effective as a tool for prevention and intervention for professional quality of life (Larsen, Stamm & Davis, 2002). The measure functions equally well in pretest-posttest settings or at intervals to measure changes across time. It is also an effective screening tool for potential risks due to the negative effects of care giving.

Caregiver burden is defined as the strain or load borne by a person who cares for an elderly, chronically ill, or disabled family member or other person (Stuckey et al). It is a multidimensional response to physical, psychological, emotional, social, and financial stressors associated with the care giving experience. It tends to worsen when the caregiver is socially isolated or lacks knowledge about the condition.

Telerehabilitation can potentially help relieve caregiver burden. If a therapy specialist comes to the home, the therapist supplies most of the intervention with little participation from the caregiver. Using telerehabilitation for physical therapy, for example, often requires participation of the caregiver to serve as an on-site assistant to the therapist for cueing and balance for the patient. The caregiver's active contribution to the therapy



session not only increases hands-on reinforcement of proper handling techniques, it allows the caregiver an opportunity to ask questions about the condition that they might not otherwise have asked. This in turn helps to relieve at least in part some of the caregiver strain and stress resulting from lack of knowledge and isolation.

### **C. Technical Analysis**

Telerehabilitation has been delivered to diverse settings via a variety of telecommunication lines and telemedicine technologies, and it is important that technology is planned appropriately. There are several variables that influence choice of technology including technological, human, and logistical components. Fitting the right technology to the right application is more efficient and cost effective. Appropriate selection can also reduce frustration and increase usage. Technology is affected by where the equipment will be used, by whom and for what disciplines.

Bandwidth consideration is an important aspect of designing the infrastructure. In general, bandwidth is directly proportional to the data carrying capacity and the cost. While high bandwidth videoconferencing equipment offers the best video, it is also usually the most expensive, though line lease costs are sometimes reduced under the Rural Health Care Division (RHCD) of Universal Services when the service is to a hospital. A line used exclusively for school speech therapy doesn't qualify for reimbursement under either Schools & Libraries or under RHCD, but the school may already have an existing line for distance-learning that can also be utilized for therapy. A broad bandwidth option is ideal when used at a facility such as a school or hospital. When it is used often, the cost of the equipment and operations can be justified. Examples of this would be for speech language pathology for school children, splinting sessions in outpatient services, Aphasia support groups, or distance learning for continued education for healthcare providers.

Telerehabilitation can be an effective tool for patients at home, but most homes have low bandwidth connections. Videophones or Internet video conferencing, commonly used over low bandwidth connections, display a great disparity in quality of motion, clarity and delays depending on type of telecommunications and technology used.

Technology using Plain Old Telephone Service (POTS) has increased in quality over the years but video quality is still limited by bandwidth. Transmission quality is more susceptible to weather, number of connections to the line, and the capabilities of the local telecommunications company. Digital Service Line (DSL) can deliver a higher quality of video, but is not available in all areas. There is also the concern for Quality of Service (QoS) regarding the video and more importantly concern for patient confidentiality whenever using DSL, since it utilizes the commodity Internet. Encryption and/or Virtual Private Networks (VPNs) would have to be included if using DSL to help safeguard patient information. The equipment for use over DSL is less available than technology designed for use over POTS or T-1 lines; but this will probably change as DSL becomes more common.

There are other factors in addition to video quality which need to be considered. Portability of the equipment from site to site or within a facility, ease of scheduling, and easy patient / provider access often outweighs the reduction in video quality. There is an individual tolerance level as well among therapists as to the level of clarity or smoothness of motion that will be acceptable that also needs to be considered when choosing technology applications.

Despite limitations due to video quality, telerehabilitation has been successfully conducted via videophones over POTS for PT, OT and speech sessions. It is important to include therapists in equipment selection when considering anything other than broadcast quality video since there is a difference in clarity, motion, speaker quality and video delay between equipment manufacturers.

If a videophone is to be used in a residence for physical therapy, a therapist will want to assess if the client can be seen as they move across the room. Some phones require the patient to remain a fixed distance to keep the picture in focus, making them a poor choice for gross motor movement. Speech therapist, on the other hand, will focus on sound quality and video that is of sufficient quality to judge fine motor motion.

*The INTEGRIS Rural Telemedicine Program began with a focus on high-end technology. In the first clinical study a H.323 video conferencing system with a dedicated T1 line was used. While this first pilot study was considered a success, challenges were identified that were associated with the use of this technology. It required the patient to travel to the nearest site where H.323 was available, which was still considerably less than the distance to a specialty rehab service. This technology was highly reliable with maximum transfer rate of 128 kbps at 30 frames per second. However, the cost of equipment and line lease were the limiting factors.*

*It was found that much of the demand for services in rural areas was for patients in their homes. High-end technology was not feasible for patient homes in most rural areas, so POTS technology was used. A decision was made not to invest in the computer/Internet platform since many of the rural patients were limited in their access and knowledge of computers.*

*For desktop videophones, INTEGRIS Rural Telemedicine Program utilizes two H.324 devices that only require making a telephone call to connect the audio and pushing a button to connect the video. The maximum transfer rate is 33.6kbps with video streaming at 18-22 frames per second and costs between \$1,000 and \$2,500.*

For more information see the OAT Technical Guidelines at <http://telehealth.hrsa.gov>.  
Oat Technical Guidelines: rehabilitation. For more information on equipment and dealing with vendors see TDRT: <http://tdrt.aticorp.org>.

## **D. Operational**

This is a general guide only for setting up a program. There are many variables – type of services to be delivered, sites to receive the service, technology utilized, patient population and so on. A project director has to be flexible and adapt to needs and various unforeseen challenges that arise when implementing a new program.

---

### Start-up – First 30 days

- If appropriate, apply for Universal Service Funds.
- Incorporate HIPAA and good consultation environment guidelines.
- Discuss protocols, scheduling, consent forms, reimbursement, billing, etc.
- Order equipment.

### 31-90 days

- Order line installations. If applying for Universal Service Funds, be sure and wait the mandatory 28 days before ordering lines.
- Continue administration logistics including where to house patient information.
- Begin laying the groundwork with licensure boards, especially physical therapy, occupational therapy and speech/language pathologists. Use the same basic approach as with the third party payers, that the service is analogous and therapy is structured to follow the “do no harm” guidance.
- Develop educational information / brochures for staff, patient, and physician information.
- Develop evaluation and data collection tools.

### 91 – 120 days

- Install equipment.
- Configure network devices.
- Test equipment.
- Begin hands-on training sessions.
- Finalize any administrative logistics.
- Trial use – preferably with an experienced clinician present to mentor.

### Begin services

- Follow program improvement steps already in place for the institution. An example of a standard program improvement is the PDCA-FOCUS format (an extension of the Plan, Do, Check, Act cycle sometimes called the Deming or Shewhart cycle).

- Continual re-education of providers, case managers, and public on services and paperwork.
- Presentations to school or hospital boards, licensure boards, providers, administrators, etc. should be held using the first few months of outcome information.
- Continual re-education/ promotion to case managers and physicians that will be referrals to the telemedicine program. It needs to be constantly shown as a viable option. Be sure that notepads, encounter forms, billing sheets, etc that are in physician and rehabilitation center areas include telerehabilitation as a special service that can be utilized.

#### **IV. Lessons Learned from the Field**

- a. The further away the remote site is from the provider, the greater the need but lower volumes because of the smaller population in the community. Residents in frontier areas have to travel the farthest distances to get healthcare yet have fewer than seven people per square mile (*U.S. Census Bureau*). The exception to this would be services delivered to a captive population, such as speech language pathology to schoolchildren in a rural area.
- b. Video quality needs to be adequate for the job.
  - i. Physical therapy has more gross motion, so tolerates less clarity. It is easier for a therapist to see the angle that a patient can lift up their arm than for a speech therapist to see the fine motor motions such as the movements of a lip or tongue. When the therapist is working with the patient on ambulation, the camera in the videophone must be able to focus on the person close, and as they walk away from the camera.
  - ii. Speech language pathology requires a higher quality video than some other therapies since it must have the ability to focus on fine motor motions. Writing materials facilitate language and cognition encounters. A removable camera - one that is connected to the videophone by a cord - allows for the camera to

- be easily moved around for close-up views of a body part or educational support items the therapist is using (e.g., book, checkbook, etc.).
- iii. Videophones offer lower quality video, but eliminate some of the provider resistance to telemedicine because of the ease of use and scheduling of the technology.
  - iv. Videophones and analog line leases are often cost effective.
- c. On-going education is essential for program start-up and development. Include all stakeholders including- but not limited to- providers, caregivers, patients, administrators, licensure boards, third-party payers, and case managers.
- i. Need to get specific buy-in from the Department Director, not just the therapists using the system (i.e., in one site, although the therapists were in favor of telehealth, the department director was NEVER in favor of doing telemedicine as reimbursement was minimal or non-existent.)
  - ii. If purchasing home care equipment - make sure it is compatible with the phone systems in the area. Purchasing the least expensive equipment may not be the best solution. One network bought equipment that was difficult to set up, and stated it never worked successfully.
  - iii. Have document cameras and fax machines available for speech consults. It will be necessary for someone to be in the room with the patient if the patient is very impaired. Sometimes a family member is sufficient.
  - iv. Much encouragement is sometimes needed to get the remote site to have a staff person available for the speech language pathology consult that may last up to one hour.
  - v. Good orientation for new therapists. It's a good idea for a telehealth staff member to sit in on the first visit to deal with any questions or problems.

## V. Useful References (websites and documents)

### Websites

American Speech-Language-Hearing Association: [www.asha.org](http://www.asha.org)

American Telemedicine Association: <http://www.americantelemed.org>

Association of Telehealth Service Providers: <http://www.atasp.org/>

INTEGRIS Rural Telemedicine Program: [www.Integrisok.com/telehealth](http://www.Integrisok.com/telehealth)

National Center for Dissemination of Disability Research: <http://www.ncddr.org/>

Telehealth Deployment Research Testbed: <http://tdrt.aticorp.org/>

Telemedicine Information Exchange: <http://tie.telemed.org/>

Measures of Traumatic Stress & Secondary Traumatic Stress:

<http://www.isu.edu/~bhstamm/tests.htm/>

### Documents

Clark, P.G., Ruwe, B., Dawson, S.J., Scheideman-Miller, Cynthia, McDonald, M., Hantla, M. *Using Telerehabilitation to Promote TBI Recovery and Transfer of Knowledge*, Journal of Neurorehabilitation, Spring 2003.

Kronenfeld, J.J., Whicker, M.L. Caring for the Young, the Sick, the Imprisoned, and the Elderly. Praeger Publishers, New York, 1990.

Scheideman-Miller, Cynthia. "INTEGRIS Rural Telemedicine Project: TeleRehab™". *Proceedings: State of the Science Conference on Telerehabilitation and Applications of Virtual Reality*. March 2002. p.18-20.

Clark, P.G., Dawson, S.J., Scheideman-Miller, Cynthia, & Post, M.L. TeleRehab: Stroke Teletherapy and Management Using Two Way Interactive Video. Neurology Report June 2002 26(2)87-93.

Dawson, S., Clark, P.G., & Scheideman-Miller, C.L. "Stroke Telerehabilitation: The New Frontier" *Physical Therapy Case Reports*. March/April 2000, 3(2).

Clark, P.G. & Scheideman-Miller, C.L. "Telehealth 'Pre-Pilot' Successful in Oklahoma. *Advance for Speech-language Pathologists & Audiologists*. 1999. 9(45), p.18-19.

Larsen, D. Stamm, B.H. & Davis, K. (2002). Telehealth for Prevention and Intervention of the Negative Effects of Caregiving. *Traumatic StressPoints*, 16, (4). <http://www.istss.org/publications/TS/Fall02/telehealth.htm>.

Figley, C.R. & Stamm, B.H. (1996). Psychometric Review of Compassion Fatigue Self Test <http://www.isu.edu/~bhstamm/pdf/figleystamm.pdf>. In B.H. Stamm (Ed), Measurement of Stress, Trauma and Adaptation. Lutherville, MD: Sidran Press.

Stamm, B. H. (2002). Measuring Compassion Satisfaction as Well as Fatigue: Developmental History of the Compassion Fatigue and Satisfaction Test. In C.R. Figley (Ed.). 107-119. Treating Compassion Fatigue. New York: Brunner Mazel.

Stamm, B. H. (2003a). The Professional Quality of Life Scale: Compassion Satisfaction and Fatigue Subscales: R-III. <http://www.isu.edu/~bhstamm/tests/ProQOL.htm>

Stamm, B. H. (2003b). Psychometric Information on The Professional Quality of Life Scale: Compassion Satisfaction and Fatigue Subscales: R-III. [http://www.isu.edu/~bhstamm/tests/ProQOL\\_psychometric.htm](http://www.isu.edu/~bhstamm/tests/ProQOL_psychometric.htm)

Stuckey , J.C., Neundorfer, M.M., Smyth, K.A. Burden or well-being: the same coin or related currency? *Gerontologist* 1996; 36(5):686-93.

**VI. Sample Clinical Protocol** (see Attachment A)

**VII. Sample Technical Protocol** (see Attachment B)



## Attachment A

### Tele-rehabilitation: Physical Therapy & Stroke Protocol

#### 1.0 PURPOSE:

To provide guidelines for physical therapy tele-presentations for stroke.

#### 2.0 APPROPRIATE PATIENT and TYPE OF INTERVENTION

##### 2.1 PATIENT

2.1.1 Unilateral lesion as verified by CT or MRI

2.1.2 Recent onset (less than 3 months)

2.1.3 Moderate to minimal impairment of functional indicator (3-4 on FIM)

##### 2.2 INTERVENTION TYPE

2.2.1 Professional consultation, either with licensed Physical Therapist (PT) or family member providing care for patient at spoke site

2.2.2 Supervision – direct audio/visual contact with registered Physical Therapy Assistant (PTA) who is providing services to the patient and for modifications of program based on the patient's response, changes or progressions.

2.2.3 Education of family/support members with active ongoing involvement and with prior knowledge of Neuro Developmental Treatment (NDT) approach, handling patterns, and recovery process

#### 3.0 REFERRAL and SCHEDULING PROCESS: As per Telemedicine Scheduling Procedure

#### 4.0 TELEMEDICINE INTERVENTION PROCEDURE:

##### Pre-examination:

4.1 Written documents Written consent by the patient or a legal designee for telehealth procedures will be obtained prior to the initiation of telehealth procedures

4.2 Patient Bill of Rights Refer to *Privacy and Security of Health Information Policy SYS-IM-112 or Patient Bill of Rights SYS-ETH-110*.

4.3 Tests/procedures Pertinent clinical documentation will be provided to the consulting clinician prior to the onset of a telehealth consultation.

4.4 Room preparation – Refer to *Telehealth Equipment Operation – ITN, One-Net or other Broadband Network Connections Policy TM-008 or Telehealth Equipment Operation – TM-003*

4.5 Patient preparation Patients receiving teleconsultations will be accompanied by a qualified clinician, coordinator, or caregiver when appropriate. Telehealth procedures will be thoroughly explained to the patient by an on-site coordinator or clinician prior to the beginning of the consultation.

### **Examination**

4.6 Equipment: In addition to the basic Video conferencing equipment, a physical therapy intervention may include fax (documentation) and remote arm camera (to show patient characteristics such as edema.) Cameras at the patient site should be set to show the whole patient initially, and then adjusted as per therapist instructions.

### **Activities:**

4.6 Patient activities to assess and manage motor control throughout the body (examples would be bending, stooping, reaching, walking, etc.)

4.7 Interactive conversation with patient and others (family, health care provider, etc.) present in the room, at the patient site.

4.8 Use of the fax or remote arm camera to transmit images of written documentation or tests (e.g., EEG) Use of the remote arm camera to focus on a smaller area for minute motor control and edema.

**Post-examination**

4.9 Patient instructions – Provider therapist will tell patient if and when they are to have a return visit, either via telemedicine or in person. The site coordinator or other health care professional responsible for the patient will note this to chart and coordinate with the telemedicine scheduler to reschedule.

4.10 Evaluation forms

---

## Attachment B

### Sample Telerehabilitation Technical Protocol

#### 1.0 Purpose:

The purpose of the Telemedicine/Telehealth policies is to provide guidelines for utilization of the Telecommunication technology for consultation for clinical and related educational services, including:

- Evaluation and clinical management assistance
- Support for patient stabilization and transport
- Avoidance of unnecessary referrals
- Consultation for routine clinical services
- Real-time, interactive specialist encounters
- Store-and-forward encounters
- Management of clinician services in remote locations or spoke sites
- Residency Supervision

#### 2.0 Definition:

2.1 Hub site – Location of provider administering clinical education, mentoring or intervention to a remote site.

2.1.1. Hub site Coordinator - The Hub Site Coordinator is a trained facilitator for sites receiving Telehealth patient encounters. He or she coordinates all aspects of telehealth conferences in collaboration with spoke site coordinators, performing routine equipment/communication line checks, scheduling routine and emergency sessions, and assisting hub site personnel with conducting telehealth sessions.

- 
- 2.1.2. Hub site (consulting) Provider – The Hub Site (consulting) Providers are consulting Physicians, Psychologists, Psychiatrists, Nurse Practitioners, Registered Nurses, Registered Physical Therapists, Registered Nutritionists, Registered Respiratory Therapists, Registered Speech Therapists, Registered Occupational Therapists, or other INTEGRIS-approved clinicians licensed to practice in the State of Oklahoma.
- 2.2. Spoke Site – remote site where a provider, patient, and/or caregiver are receiving services via telemedicine/telehealth.
- 2.2.1. Spoke Care Providers are referring practitioners who are Physicians, Physician Assistants, and Nurse Practitioners, Registered Nurses or other licensed care providers with current Oklahoma State licensure, located in rural facilities within the state of Oklahoma connected via the INTEGRIS Telehealth Network.
- 2.2.2. Spoke Site Coordinator – The Spoke Site Coordinator is a trained staff member who prepares Telehealth equipment for contact with hub sites, coordinates telehealth sessions, performs routine checks on Telehealth equipment, and develops and distributes information for successful telehealth sessions at their specific spoke site. Each spoke facility may have several Spoke Site Coordinators depending upon the nature and number of programs being offered at the facility.
- 2.3. Telehealth Encounters – Telemedicine/ Telehealth encounters are defined as patient encounters and patient related activities that involve consulting among physicians, therapists, and other health care professionals in various locations for time-critical care and cases that require second opinions or specialty care. Physicians, discharge planners or home health staff can make patient referrals for telehealth services. A physician's order is required for services. Emergent telehealth encounters take priority over all other activities on the INTEGRIS Telehealth Network.

### 2.3.1. Elective Subspecialty Telehealth Consults:

Elective Telehealth encounters are conducted through scheduled appointments. The spoke health care provider, qualified clinician or caregiver may serve as presenter during the consultation to assist the hub site provider. History, physical examination, findings and/or diagnostic data will be available for review by the hub site (consulting) provider prior to or at the time of the telehealth consultation. Findings, the consulting provider will document treatment plans and other necessary. A record of this will be provided to the referring clinician or student's school record, if standard procedure.

## 3.0 Training and Staff Development

All Telehealth team members, including coordinators, clinicians, educational presenters, and administrative personnel, will be trained by the hub or spoke Telehealth Coordinator, as appropriate. Training will be provided in operating telehealth equipment, telehealth policies and procedures, problem troubleshooting, presentation guidelines, and other information necessary to insure safe, high quality use of the Telemedicine/ Telehealth Technology.

## 4.0 Telehealth Encounters

- 4.1 Patients receiving tele-encounters will be accompanied by a qualified clinician, coordinator, or caregiver whenever appropriate. Telehealth procedures will be thoroughly explained to the patient by an on-site coordinator or clinician prior to the beginning of the consultation.
- 4.2 Telehealth procedures will be thoroughly explained to the patient by an on-site coordinator or clinician prior to the beginning of the consultation.
- 4.3 Written consent by the patient or a legal designee for telehealth procedures will be obtained prior to the initiation of telehealth procedures .

- 
- 4.4 The Spoke Care Provider or qualified designee, if present, will assist the consulting physician throughout the procedure by positioning the patient for optimal viewing, operating the teleconference system and peripheral examination devices (e.g. secondary camera), supporting the patient and family during the consultation and providing other support as required by the Consulting Care Provider.
  - 4.5 Pertinent clinical documentation will be provided to the consulting clinician prior to the onset of a telehealth consultation.
  - 4.6 The Consulting Care Provider will document all pertinent clinical information, findings, and orders/prescriptions and will provide this documentation to the spoke provider via mail, fax, e-mail or electronic medical records system at the conclusion of the consultation.

## Chapter Twelve

---

### **School-based Telehealth**

**Authors:** Ryan J. Spaulding, PhD, University of Kansas

Gary Doolittle, MD, University of Kansas

Deborah L. Swirczynski, MA, University of Kansas

#### **Contributing Editors:**

Rob Sprang, MBA, University of Kentucky

Rick Phillips, University of Kentucky

Sue Fox, North Idaho Rural Health Consortium

#### **I. Introduction**

During the past decade, telehealth networks have significantly expanded across the United States, making telehealth a common component in the delivery of everyday healthcare. The services provided via telehealth range from primary care to sub-specialty care found in leading academic medical centers, and services are provided across the lifespan. Telehealth systems can now be found in virtually any organization that provides health care, including hospitals, clinics, nursing homes, homes, assisted living facilities, schools, prisons, health departments, and others. Importantly, telehealth does not create new medical services but provides an alternative mechanism for delivering existing services.

The information contained in this document is designed to help those interested in entering the world of school-based telehealth. It will give the reader a comprehensive overview of the steps necessary for the development of a successful network that will deliver one or more telehealth services via an interactive video network. This document does not address “store-and-forward” telehealth services.



This work is supported by a grant from the Health Resources and Services Administration's Office for the Advancement of Telehealth (OAT). The document is based on real world experiences, which include many lessons learned from practitioners with proven success in delivering telehealth services to underserved areas.

The reader will see many references to specific manufacturers, vendors, and equipment. These references are made simply to indicate the equipment some programs are using or have used in the past. They are not an endorsement of any company or product.

## **II. Background**

### **A. Specialty Area**

In general, school-based telehealth projects deliver health care directly to the place where the patient is located – in the school. School-based telehealth can offer several advantages to its participants:

- The service comes to the child instead of the child relying on the parent or guardian to take the child to the off-campus site to receive service.
- Although parents often travel to the school to participate in the telemedicine encounters, parents do not have to leave their places of employment, travel to the school, and then to the location of the health care clinic. Therefore, parents do not have to spend as much time away from their jobs or other responsibilities.
- School-based telehealth projects that emphasize children with special needs, for example, can significantly reduce the travel time and expense of health professionals who normally would travel to the schools; these schools are often dispersed across long distances in rural areas. At times, it is difficult to get health professionals to travel to schools at all.

- 
- Costly trips to the emergency room for routine illnesses might be reduced as parents become aware of telemedicine as a viable alternative for primary care for their children. This outcome could have a significant cost-benefit to the health care system.
  - The school nurse or special education paraprofessional can review the recommendations of the health care professional with the student and parent. This may extend into situations in which the school nurse can monitor the patient's compliance with the physician's prescription orders or requests for a follow-up visit.

The ultimate goal of school based-telehealth is to facilitate classroom success by providing health care services to children, who, in many cases, would not receive health care in a timely manner, if at all (Please see a sample of Success Stories in Attachment A). The sooner a healthy child returns to the classroom, the sooner learning can resume. Besides the learning benefit, school-based telemedicine clinics provide other advantages to the school and community.

- In states where school funding is based on average daily attendance, having children in the classroom instead of at home or at a doctor's office has a direct financial benefit to the school district.
- The local community may also benefit from school-based telehealth by increasing the productivity of parents in the workplace.
- In situations in which the health care provider would normally travel to the school, school-based telemedicine can reduce provider travel time, fatigue, and cost.
- Health professionals can also participate in health-related meetings or events, such as Individualized Education Planning (IEP) meetings, in a time-efficient and convenient manner.

During a school-based telehealth encounter, teleconferencing technology connects a school with a health care provider, enabling school children with a wide variety of health conditions to consult with the health professional from the convenience of the school. The key element in any school-based telemedicine program is that the need for the services is significant and that the service can be delivered appropriately via interactive tele-video (ITV).

*One example of a school-based project is known as TeleKidcare®. TeleKidcare was designed and implemented by the Kansas University Medical Center (KUMC) specifically to address the shared community goal of keeping children healthy and in school by providing health care service to underserved children while at school. Whether the school-based telemedicine clinic is located in an urban or rural area, schools connect with local providers for clinical encounters. While TeleKidcare focuses on acute or urgent care situations as well as behavioral health conditions, other school-based telemedicine projects concentrate on delivering health care service to children with specific chronic conditions such as asthma, diabetes, or obesity. Some deliver support services for children with individualized education plans (IEP); this may include interaction with a speech pathologist or a physical or occupational therapist. In addition, autism assessments for students in rural communities have been completed via telemedicine, and a behavioral psychologist has developed psycho-social group counseling sessions to discuss and explore health and nutrition education for elementary school children whose body mass index (BMI) is significantly elevated.*

## **B. General Data and Trends of School-based Telehealth Projects**

School-based telehealth projects have been in existence for less than ten years, and therefore, the assessment of trends in the field's growth is in its infancy. The Office for the Advancement of Telehealth (OAT) website indicates that there are currently three OAT-funded projects in the United States that provide pediatric primary care to school-aged children in their home schools. As might be expected, there is little comprehensive trend data for school-based telehealth.

To get these data for the industry, it would be prudent to begin collecting various data sets early in the operation of a school-based telehealth project. Collecting baseline data prior to beginning the service or collecting them retrospectively once the service has begun is also a good idea. These data will help determine utilization of the service and in understanding factors that influence its success. Demographic data, as well as

focused-research data, will be useful. A standardized form could be used to collect basic demographic information across all encounters, and research instruments may be employed depending on the needs of any studies that are being conducted. In general, it has been found that three factors tend to influence usage rates in urban areas: a school nurse who is an enthusiastic proponent of school-based telehealth; elementary settings where younger students tend to experience a greater number of routine childhood illnesses (i.e. ear infections, strep infections, etc.); and schools where there is a high percentage of children who participate in the federal Free and Reduced School Lunch program. In rural areas, the first two factors are also true; however, the third factor tends to be more closely related to geographic distances between the home, school, the workplace, and the proximity of the health care provider.

*Growth and usage trends in Kansas are encouraging. The TeleKidcare pilot program was launched in February of 1998 in four elementary schools in Kansas City, Kansas, Unified School District 500 (USD 500). During the next several years, additional schools were added, resulting in 10 USD 500 schools offering TeleKidcare® services in the 2002-03 school year; nine of these schools are elementary schools and one is a middle school. An additional 15 schools initiated school-based telemedicine programs in communities outside of the greater Kansas City area. Since February of 1998, over 2000 school-based telemedicine encounters have been conducted in these 25 schools. A similar model is found in Kentucky in which children using the community school-based telehealth system for primary care can also link to the University of Kentucky Medical Center in the event that specialty care is needed. Since 1998, the Kentucky school-based project has conducted approximately 500 encounters with children originating from four schools.*

*In Kansas, school-based telemedicine encounters are divided into two categories. The first category is acute care, which encompasses all physical illnesses. The second category is designated as mental health conditions. Of the 2000 plus school-based telemedicine visits conducted since 1998 in Kansas schools, 73% were for acute care, and 27% were for mental health/behavioral concerns.*

There are a number of other school-based telehealth outcomes that could be demonstrated, depending on the specific aspects of the project. For acute and behavioral pediatric care, and special needs care, outcomes might include:

- Number of emergency room visits prevented (measure asked of parents)
- Reduction in student absenteeism (measured by length of consult and patient disposition after encounter)
- Effect on parent(s) (time effect, economic effect)

- Reduction in miles traveled for health care providers
- Reduction in provider travel time
- Number of students with access to care who previously did not have it
- Educational performance (methodologically difficult)

**Figure 1: Breakdown of School Based Encounters**

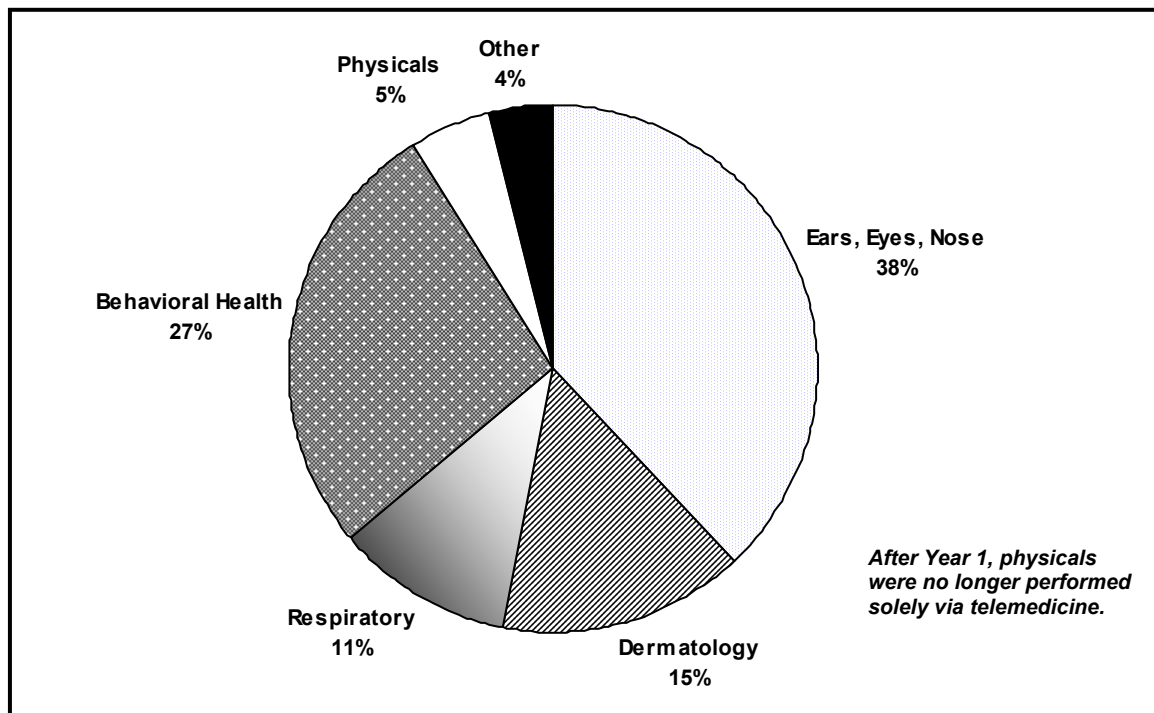

### **C. Definitions Specific to Specialty Area**

For the purposes of this document, TeleKidcare is primarily defined as a “telemedicine” service instead of a “telehealth” service, since the encounters typically involve a physician interacting with a patient.

In school-based telemedicine programs, the vast majority of ITV encounters include a student as the patient. However, the role of the facilitator on the school side can be filled by any number of individuals. In many instances, a school nurse will serve as the presenter. Some schools require that the nurse have an RN degree; others will accept an LPN. Often rural school districts do not have the economic resources to retain a

nurse; instead oversight of the school health room is delegated to a paraprofessional or to school office personnel.

In the case of ITV encounters with psychiatrists, behavioral specialists, or occupational or physical therapists, the presenting personnel at the school may be a counselor, social worker, or special education paraprofessional.

The primary requirements of the school-side presenting personnel are familiarity with the equipment and protocols, a good working relationship with the health care provider on the distant side, and knowledge and training in their particular area of expertise.

For ease of readability, the term “school nurse” will be used throughout this document when referring to the presenting personnel at the school. However, as noted above, a wide variety of individuals may serve in this capacity.

### **III. Step-by-Step Guide to Creating a Successful Program**

#### **A. Creating a Telehealth Program Within An Institution**

Gauging initial needs and interest in school-based telehealth is a critical step that should be completed before implementing such a project. Successful telehealth programs are typically driven from the “bottom-up” based on needs and efforts of end users and clinical champions. Additionally, developing a project within an institution that has a strong outreach mission is one way to justify the project. If an institution already has an active telehealth department, many other administrative obstacles have already been overcome.

It would be useful to contact other existing school-based programs to gain some initial guidance about the project and the numerous considerations when developing a startup program. Today, there are many sources and websites that offer help and instruction about establishing school-based telehealth. Some of these are included at the end of this document. To locate an organization that may already have experience in delivering school-based health care via telemedicine, a good contact source is the

Office for the Advancement of Telehealth (OAT). In the absence of an established mentor, frequent, well-planned meetings with potential partners in the project are suggested. Also, establishing relationships and support at the state level is strongly recommended. Doing so can enhance efforts to establish a school-based project, especially for funding purposes.

*In 1997 school nurses from the local Kansas City, Kansas unified school district (USD 500) reported an emergent alarming trend among school children who were unable to access health care for routine acute conditions. Recognizing that KUMC and the school district were both positioned in the urban core of Kansas City, Kansas, KUMC's Center for TeleMedicine and TeleHealth, Pediatric Clinic, and Child Psychiatric Clinic, and USD 500 worked together to develop TeleKidcare. It consisted of interactive tele-video (ITV) systems that were placed in the school health office and in the KU Pediatric Clinic and the Child Psychiatric Clinic. Because of KUMC's outreach mission and the existence of a successful telemedicine program, when the school-based telemedicine concept was proposed several years later, promoting the TeleKidcare® project within the institution was not difficult.*

*With TeleKidcare, a team representing KUCTT, USD 500, and KUMC physicians spent nearly 12 months constructing the school-based telehealth model. Taking into account lessons learned from experience with rural health care telemedicine clinics, the KUCTT staff was cognizant of the importance of user-friendly, reliable equipment, training, and confidence of the on-site facilitator, and the marriage of sufficient bandwidth to affordable telecommunication line cost.*

Sometimes the school-based services that are offered are dictated not only by need, but also by what can be reimbursed. In North Idaho, for example, children with special needs regularly receive speech, physical, and occupational therapy services in the traditional face-to-face setting. However, at times due to geographic, weather, and transportation restrictions, it was impossible to deliver these necessary services in the traditional manner. In addition, when the weather did cooperate, therapists spent many hours on the road traveling from site-to-site instead of actually providing professional services. Since services furnished to special needs children were reimbursable, a portion of speech therapy, physical therapy, and occupational therapy were incorporated into North Idaho's school-based telehealth project.

This change in the delivery mode of services has had several positive effects.

Therapists now are able to spend more time delivering services, instead of interacting with the patients on a limited basis, the therapist had additional opportunities to be

involved with the direct rehabilitation of the student via telemedicine. Due to the increased contact time, schools were able document increased service time and to bill accordingly. Delivery of care was no longer dependent on weather or road conditions. Support personnel were protected from the potential hazard of delivering specialized services in treacherous weather conditions. Thus, as is the case with speech therapists in Idaho, the most successful telehealth projects are those that improve the efficiencies or costs of existing health care services.

*Before instituting TeleKidcare, advance preparation was required. The selected school nurses spent two full days in training sessions. Protocols were developed, reviewed and modified as needed to fit the established pattern of care provided in the school health clinic; the nurses and physicians spent time together to facilitate the beginning of a cohesive working relationship; and time was devoted to becoming accustomed to the equipment. It is important that the nurses and the physicians feel comfortable with each other and the equipment before initiating services.*

Figure 2: A school nurse using the stethoscope.



Identifying costs, reimbursement, funding sources and sustainability issues of a proposed school-based telehealth project will be necessary at some point, preferably during the planning stages. Schools generally have limited budgets, preventing the purchase of expensive equipment or the maintenance of costs associated with telehealth. Grant funding is possible, depending on the specific circumstances and the ability to prepare grant applications. Many federal, state and local funding sources are



also available to fund health projects for underserved populations. These can often be found through the institution's research institute or endowment office. For smaller, rural health clinics or hospitals, there is a significant amount of state and federal funding available for technological infrastructure improvements. A good place to begin a search is the Universal Service Administrative Company (USAC) ([www.universalservice.org](http://www.universalservice.org)) which administers the Universal Service Fund established by the Federal Communications Commission. One specific USAC program was established to provide communities, particularly rural ones, with affordable telecommunication services when those services are used for health care purposes.

*TeleKidcare was launched in February 1998. During the first 3½ months, 187 encounters were conducted. The school nurses and physicians tested the limits of the equipment and the types of encounters that were possible with the technology. They learned that while many portions of a routine complete physical assessment could be accomplished over the system, several key portions of the exam could not be satisfactorily completed. During most telemedicine interventions, the experienced hands of the on-site nurse can provide adequate descriptive information for the physician; for example, the school nurse is adept at palpating lymph glands and differentiating between small gravel-sized, pea-sized, or grape-sized glands. If a skin rash is not easily discernable via telemedicine, the school nurse might use descriptors such as papular (raised), macular (flat), scattered, wheals (elevated ridges), erythematic (redness) or patches to relay pertinent information to the physician. However, in the case of a thorough physical, on-site nurses and distant-site physicians alike were uncomfortable with the limitations of telemedicine. Physicians felt it imperative that their hands actually touch the patient for the abdominal examination; school nurses were uncomfortable with the state of undress that the student needed to be in for the physical examination and were hesitant to be involved with medical judgments such as the Tanner Scale which codifies growth and development state of the reproductive system. After several months of analyzing the restrictions of the telemedicine physical, it was decided to remove the routine complete physical exam from the list of possible telemedicine consults. However, decisions regarding the clinical capabilities of specific telemedicine applications will need to be made by involved project personnel. Initiating pilot projects for new procedures or services before full-scale implementation would be informative.*

It is nearly impossible to know if a child's ear infection, left untreated, would have required a visit to the emergency room, hospitalization, or surgery. This makes it very difficult to gauge the cost-benefit relationship of a school-based telemedicine clinic; Extending this scenario, it is also impossible to know if an untreated ear infection would eventually lead to hearing and speech difficulties that could contribute to lowered academic progress and possible negative behavior displays in the classroom.

*The originating pilot program of TeleKidcare was jointly funded by KUMC and USD 500. Both organizations were responsible for purchasing the selected ITV equipment for their respective sites and for installing and maintaining the telecommunication lines. Later, funding was obtained from a US Department of Commerce, National Telecommunications and Information Administration (NTIA), Technology Opportunities Program (TOP) grant. Other local foundations provided equipment grants, including: Wyandotte (County) Health Foundation, SBC Foundation, and the Prime Health Foundation. The Kansas City-based Kauffman Foundation provided financial support to sustain the program while reimbursement policies were researched and developed. In addition, the state of Kansas has supported the expansion of TeleKidcare® to rural communities throughout the state.*

*In March 2003, two top-level KUMC officials published an editorial in the Kansas City Star. The editorial stated that during the past year KUMC provided more than \$39 million in uncompensated hospital care, an increase of more than 30% from the previous year. The article further noted that people who do not have health insurance tend to put off going to the doctor and tend to present in a worse physical condition when they do receive care. When the uninsured finally seek care, it is usually through the nearest emergency room, the most expensive delivery system for acute health care conditions. This article confirmed the notion that TeleKidcare® may prevent some emergency room visits and that KUMC fully supported this intervention.*

*Although difficult to measure the potential cost savings afforded by TeleKidcare, the average cost of a pediatric visit to KUMC's emergency room is \$200 to \$300. Since 1998, 2000 children have been seen via TeleKidcare. If only 25 percent of the TeleKidcare visits necessitated routine care in the emergency room, the cost to KUMC—and the health care system—would have been from \$100,000 to \$150,000.*

Generally, the average cost of a telemedicine encounter is strongly influenced by the accumulated number of encounters provided at a site. An early cost analysis suggested that as the total number of telemedicine encounters at a given site approaches 165, the average cost of a school-based telemedicine encounter and that of a face-to-face consult performed in a medical center pediatric ambulatory clinic is approximately equal<sup>2</sup>. Furthermore, as the cumulative number of telemedicine consults at a given site exceeds 200, the average cost for a school-based telemedicine encounter is estimated to be equal to or about 9.5% less than that for a conventional ambulatory care visit. Based on this research, if a site is conducting an average of 40 encounters per month, the total cost per visit would be equal to or less than a medical center visit after five months of operation. As the number of telemedicine encounters continues to increase, the average cost per visit would continue to decrease. For a more detailed description of this cost study, please see Doolittle, Williams and Cook (2003) listed in the reference section.

In October 2001, Medicare instituted a newly revised telemedicine policy. This policy primarily impacted reimbursement procedures in rural areas where health care was being delivered at or from a health care facility. Although Medicare reimbursement is not directly applicable to school-based telehealth due to the age of the beneficiaries, the Medicare policy established the climate for other carriers to initiate telehealth policies. As a result, it is now easier to work with state Medicaid offices and with commercial insurers to develop telemedicine reimbursement policies. Data that demonstrates a positive effect of telemedicine on Medicaid funding for patients, such as a reduction in cost as the result of providing preventative care, is recommended. With federal and state reimbursement policies in place, more private insurance companies are expected to adopt similar plans. It is expected that insurance reimbursement will significantly increase the likelihood of long-term sustainability.

*In 2001, KUCTT began discussions with the Kansas Medicaid office to develop a telehealth reimbursement policy for telehealth in Kansas. The 2001 Medicare policy provided the basis for this discussion and was used as a starting point for a Kansas Medicaid policy that expanded on the services covered by Medicare. The requested expansion included an increased number of CPT codes and reimbursement for encounters originating from school sites. This policy became effective in Kansas on June 18, 2004 and will begin reimbursing for TeleKidcare consults during the 2004-05 school year.*

Gaining acceptance by staff physicians and faculty is important for the success of school-based telehealth. Of potential importance to the physicians is the firm conviction that through this school-based telemedicine program, health care is being provided to children who would otherwise not receive it. At teaching hospitals, it is possible to incorporate the service into the required rotation segment in the medical educational experience of pediatric residents. Exposure to telemedicine and its propensity to deliver both routine and specialized health care plays an important role in the total education of physicians who will ultimately serve patients in urban, suburban, or rural settings.

School-based telemedicine can also introduce families to the local health care system. Prior to participating in a school-based telehealth encounter at the local school, families often times do not have an established relationship with a primary care physician. To

many people, the health care system can be confusing and intimidating. School-based telehealth can provide a safe, non-threatening pathway into the system, allowing families to develop an ongoing relationship with a health care provider. This same phenomenon occurs in rural communities where school-based telemedicine provides an introduction to a local health care provider.

*Initial physician reaction to the concept of school-based telemedicine was mixed. In fact, the KUMC physician who orchestrated the first school-based telemedicine visit, and who currently oversees pediatric resident physicians participating in the program, was skeptical in the beginning. The physician was uncomfortable with the idea of examining a child without the benefit provided in a traditional face-to-face consult. She explained her skepticism this way. "We were trained to use a hands-on approach in our examinations. We were trained to touch and feel our patients. The idea that we were going to examine someone whom we could not physically touch just seemed odd. I honestly didn't believe that it could be done effectively."*

*Despite initial reservations, the physician recognized the potential benefits that TeleKidcare could provide. School-based telemedicine offered a way to reach children who otherwise would not receive needed medical care. Keeping that goal in mind, she maintained an open mind and decided to give telemedicine a try. She was so pleased with the results of her electronic encounters that she incorporated telemedicine into the pediatric resident training program.*

As an innovation, school-based telehealth programs diffuse throughout the community in a gradual fashion. Besides the normal factors that influence the acceptance of change, several unique considerations affect this rate. Initially, a school-based telehealth program is not dropped into an environment void of activity. The school health room is one of the busiest areas in any school. At any time, the school nurse is expected to respond cheerfully and accurately to any health-related situation. Finding time in this busy office to integrate a new program is a challenge and requires not only a nurse committed to telemedicine and the health care benefits that will be realized by the community, but also school administrators who will support and encourage the full integration of the project. Furthermore, the capabilities of telemedicine are not easily described in a paragraph or a memo sent home to parents. Parents and children generally need to see a hands-on demonstration to appreciate the viability of a telemedicine encounter.

From the very beginning of the telemedicine planning process, care should be taken to include the organization's information technology (IT) representatives. These technology experts will be helpful in deciding what networks are currently available internally and externally, as well as many other technical issues. They also will be needed once the project is implemented and operating, so it is wise to include them in the early decision-making.

The importance of creating the organizational structure to support the program cannot be overemphasized. A successful school-based program will have a person or process in place that will provide leadership, training, and support to the participants. The availability of technology support can vary among school districts; therefore, technicians might serve as telehealth equipment troubleshooters for the schools that are participating in the project. In general, four other key functions or positions could be considered: project coordinator, medical director, technical coordinator, and centralized scheduler. These positions are recommended but may vary depending on the needs of the particular project; these positions may also be full- or part-time

Project Coordinator: In a school-based telehealth program, the participants at the school as well as the health care providers have many other duties and responsibilities in addition to their involvement with telemedicine. It is helpful to have a third entity assigned to the coordination or administrative duties specific to the project. Specific areas of focus might include facilitation of communication between the school and the provider; development of information or marketing literature; presentation of forums or discussion sessions with parents and faculty explaining the purpose and capabilities of the program; and investigation of topics relevant to the program such as funding opportunities or expansion of services.

Clinical Director: It is a good idea to identify and recruit a clinical director to oversee the program. A physician or nurse who has worked within the sponsoring organization for a number of years is ideal. This person will be invaluable in providing clinical advice that is not usually available from administrative or support staff. The clinical director will also be more knowledgeable about other health care issues and the manner in which to

approach them. Finally, the clinical director will likely have long-standing relationships with numerous other health professionals who might be interested in becoming telehealth practitioners.

Technical Coordinator: The insight and problem solving skills of a technical support person are also valuable. Although the quality and reliability of commercial ITV systems have improved dramatically in the past few years (and this pace will continue to progress at an even faster rate in the future), technical glitches remain. It is imperative that participants and users of telemedicine perceive the equipment and system as reliable and user-friendly. If technical problems are constantly interfering with conducting an encounter, eventually, the users will revert back to the former method of providing health care services. Technical support personnel can also concentrate on researching the latest advancements in technology or communication processes. The technical coordinator should work closely with technicians at each school to ensure smooth coordination and understanding of the technology systems. Telecommunication line maintenance and troubleshooting that is required on lines between telemedicine network facilities can be performed by the telecommunications provider.

Centralized Scheduler: The scheduling process can be one seemingly insignificant activity that can easily make or break a project. Employing someone who is familiar with all the sites, nurses, physicians, paperwork, and telehealth processes is invaluable in making a school-based project function smoothly. With the high volume urban TeleKidcare project, a centralized scheduler is essential to coordinate the school nurse, clinician and family on relatively short notice, since most acute encounters occur within 60 minutes of the request. With some programs, an automated scheduler could be used, particularly if the appointments are scheduled well in advance. Having a centralized database for the scheduler, in which referral and encounter information is maintained, is also a plus. However, in rural settings where the volume of school-based telemedicine physician consults is reduced, often the health care provider clinic's designated scheduler can manipulate appointments in order to accommodate an acute or urgent request for an ITV consult.

Finally, be sure that the health and support personnel are available to operate the program before approaching sites and offering services. A project can easily deteriorate if services are offered to a site and then not delivered.

*Some school-based telemedicine projects (St. Claire TeleCare in eastern Kentucky, Rick Phillips, program director) not only schedule the encounters but also gather patient information (including medical history and insurance coverage). St. Claire TeleCare has consciously assumed these duties in a deliberate effort to ease the clerical burden on the school nurse. In the KUMC school-based project, a centralized scheduler establishes the encounter time as well as gathers an initial amount of demographic information on the patient. However, the school nurse is responsible for gathering direct patient information such as recent medical history and parental contact details and transferring (faxing) it to the provider. In the rural Kansas school-based telemedicine community projects, the scheduling is generally handled by the provider. Each community has established its own unique process that integrates smoothly into its office routine and meets the needs of the school-based telemedicine clinics.*

## **B. Planning the Program to Meet the Needs of the Underserved**

A few options are available to assess the health care needs in a particular state. The state health department can provide demographic data regarding health care trends and needs. State or federal reports are often available that identify physician shortage areas or medically underserved areas (MUA's). Similarly, geographic areas meeting certain specified criteria for socio-economic status can be found by contacting the state Medicaid office or the state office of rural health. Existing patient referral patterns should be available from the telehealth parent institution or other local hospitals or medical centers.

In addition to the endorsement of the institution, when selecting communities to participate, it will be prudent to examine the endorsement and commitment of three community entities: the school system; the local health care provider; and community businesses and organizations.

The School System: The school system should be committed to providing a percentage of the school nurse's time, and a room that will provide a private, confidential setting for health care consults. There should also be evidence of a need for telemedicine to

overcome barriers encountered by families when attempting to access health care for their children.

*When TeleKidcare was first developed, liability issues represented a major concern and a potential stumbling block to USD 500 administrators. Great care was taken in developing the consent forms, resulting in document that is still in use today (see Attachment B). Consent forms were reviewed and edited by attorneys representing KUMC and USD 500. The USD 500 consent form is universally used as a template by the rural TeleKidcare sites when developing their community-based consent forms.*

The Health Care Provider: The health care provider should demonstrate a commitment to this project by providing professional health care services and administrative time related to scheduling encounters. Additionally, other community health care organizations, clinics, and physicians in private practice should endorse the concept of school-based telehealth and understand that the goal is to help parents access health care for their children, not lure patients away from established medical homes. If this concept is not accepted and thoroughly understood by all community health care delivery organizations, conflicts will adversely affect the implementation of the project.

Community Businesses and Organizations: Community businesses may be able to provide funding for such things as prescription medications for families that cannot afford them. Community organizations can help sustain and support the project by offering funding and generating community-wide awareness of and support for telehealth.

In rural areas, geographic isolation is often the precipitating factor that motivates a community to look toward telemedicine to relieve the hardships encountered when attempting to access health care. Sparsely populated communities often consolidate schools which result in longer travel time from home to school to parents' places of employment to the primary care physician (if even available). In addition, socio-economic status can present salient limiting factors to rural citizens when accessing health care.

Just as primary health care providers are often not available in remote areas, specialists are even less available. One key advantage of statewide TeleKidcare is the involvement



of the local rural provider. State funding provides support for the installation of ITV equipment and telecommunication lines in the office of the local rural participating provider. If a student does need to access specialty services, the local rural physician can contact KUMC to arrange a telemedicine encounter with the appropriate specialist. The encounter between the specialist and the student can either take place through a connection to the school-based telemedicine health room or at the office of the local physician.

Early in the planning stages of a school-based telehealth program in which a single physician or health care organization will serve as the primary provider, all local health care professionals should be contacted and introduced to the program. Currently, equipment and connectivity costs prohibit placing ITV systems in every community clinic or health care office. Members of the community's medical entourage should understand the goals and purposes of the project are to create increased access to health care for school children, not to infringe on a provider's established patient base. Processes can be implemented that will facilitate communication between health care providers concerning a shared patient. For instance, in the TeleKidcare project, when parents provide the school nurse with information regarding the student's primary care physician, the school nurse will fax the clinic notes generated by the telemedicine consult to the noted primary care provider (PCP). The common goal of the health care community is to ensure that the health care needs of the child are met and that the PCP has a complete record of all health-related interventions.

Having communities that express an interest in school-based telehealth present a plan reflecting a needs assessment and the manner in which a school-based telemedicine clinic can address those needs is a good way to identify needy areas and community commitment. The community as a whole should establish partnerships and develop relationships among its members to support the effort to increase access to health care.

Community leaders may want to conduct a series of meetings with the local stakeholders committed to the development of a school-based telehealth program. Communities that diligently develop the project and deliberately cultivate a diverse

planning committee representing a wide variety of community interests, ultimately produce strong, vibrant, and successful programs. In these meetings, a whole range of relevant topics can be addressed, such as project implementation, reimbursement, goals, and other health care issues. One example of a health care issue, HIPAA, is discussed next.

### **HIPAA (Health Insurance Portability and Accountability Act of 1996)**

The goal of HIPAA is to ensure the privacy, confidentiality, and security of medical information and to improve the portability and continuity of health care coverage. Therefore, health care providers who transmit any health information electronically (including via fax) are subject to the provisions of HIPAA. The effective compliance date of the privacy rules was April 14, 2003. HIPAA security rules have an effective compliance date of April 21, 2005.

According to HIPAA, health information about a patient can be used by and disclosed to only those physicians or employees within the facility as is necessary for treatment of the patient, and must not be discussed elsewhere in the facility. Although schools and school health records are covered by separate privacy guidelines, facilitators at school-based telehealth programs should be notified and informed of the significance of HIPAA regulations and cautioned to be diligent in protecting the privacy rights of telehealth patients.

One of HIPAA's primary provisions is to ensure the privacy of "protected health information" (PHI) which is essentially any electronic information that can be used to identify an individual. A special effort must be made to keep protected health information confidential.

To ensure that the school-based initiative complies with HIPAA regulations, the school and the health care organization should install a dedicated fax machine in a secure location to be used for the transmission of patient information. Any patient information that can be identified as belonging to a particular individual needs to either be kept in a locked location or destroyed, preferably by shredding.

E-mails that refer to patients should not include patient names; names or other identifying factors should be kept separate from symptoms or diagnoses when possible. E-mails containing any patient-related information should only be exchanged over a secure, protected network.

In addition, HIPAA requires that when patient information is gathered for the delivery of health care, the patient must be supplied with the providing institution's Notice of Privacy Practices (NPP). Because telemedicine provides health care across geographic distances, arrangements must be made to provide all telemedicine patients with an NPP. The NPP can be provided by the school nurse to the parent at the time of the encounter, or mailed to the parent by the local health care provider if the parent is not available for the consultation. Additionally, school-based projects may be affected by HIPAA Business Associate guidelines, thus requiring a business associate agreement between participating schools and the health provider. For additional HIPAA information, please refer to the Health and Human Services webpage at [www.hhs.gov](http://www.hhs.gov).

### **Costs and Startup Issues**

Clearly, the cost associated with implementing and maintaining a school-based telehealth program is a significant factor in planning for such a service. Although the cost of providing telemedicine has dropped dramatically over the last decade, it remains fairly expensive, especially at startup. It is important to negotiate with multiple vendors at every level in the planning process, particularly regarding telecommunication network charges. The range of prices can vary by as much as 400%. Additionally, institutions may already have contracts in place with vendors that may also supply telehealth equipment. Please see Attachment C for a list of the potential costs of a school-based telemedicine project:

Once community commitment is established and costs are calculated and agreed upon, agreements must be developed that outline who will be responsible for various aspects of the project. Formal contracts or memorandums of agreement are recommended (see

Attachment D for a sample of a Memorandum of Agreement). These might document how revenue will be collected and distributed, or how evaluation data is collected. Typically, a school nurse or school site facilitator can collect patient information and research data, as appropriate. Some basic information might include demographic information, present health care symptoms, outcomes of the consult, and parent satisfaction surveys. Please see Attachment E for a sample data collection form.

At this stage of the development of telemedicine across the U.S., most states have a telemedicine or telehealth leader that can assist or advise others regarding the intricacies of establishing a telemedicine practice or clinic. This assistance might include knowledge of the various equipment vendors, state and local telecommunication infrastructures, telehealth grants and contracts for reducing equipments costs and installation fees, and other suggestions for project implementation. This leader may be a state-supported entity or they may be associated with a medical center or school of medicine. It would be in the best interest of a telemedicine novice to seek out the appropriate agency and solicit its support and expertise before initiating a telemedicine project.

### **C. Technical Analysis**

Acknowledging that each program will need to tailor its plans to fit the different circumstances faced, the objective of this section is to provide a general overview and an understanding of the type of equipment that is needed and the network options that should be considered when implementing a telemedicine service. For more detailed information, please review the Technical Chapter of this volume or talk a local telecommunication provider.

#### 1. Equipment

##### A. Interactive Tele-video (ITV) System

ITV systems generally consist of a video camera, a coder-decoder (CODEC), an audio microphone and a video monitor. The CODEC is a device that encodes and decodes the digital video and audio signals at each end of the interactive

link. A complete ITV system is needed at each site of service for a viable telemedicine connection to occur.

### B. Medical Peripherals

These devices connect to ports in the ITV system and enhance the clinical capabilities of the equipment.

1. Video Otoscope (with Light Platform) for viewing the eyes, ears, nose, and throat of the patient.
2. Analog Stethoscope.
3. Dermoscope used specifically for enhanced viewing of skin conditions.

Listed below in alphabetical order are several of the primary vendors of telemedicine and telehealth equipment:

- AdTran, Inc. ([www.adtran.com](http://www.adtran.com))
- American Medical Development (AMD) ([www.amdtelemedicine.com](http://www.amdtelemedicine.com))
- American TeleCare ([www.americantelecare.com](http://www.americantelecare.com))
- Forgent ([www.forgent.com](http://www.forgent.com))
- Polycom ([www.Polycom.com](http://www.Polycom.com))
- RSI ([www.RSIsystems.com](http://www.RSIsystems.com))
- Sony ([http://bssc.sel.sony.com/Professional/markets/market\\_10010.html?m=10010](http://bssc.sel.sony.com/Professional/markets/market_10010.html?m=10010))
- Tandberg ([www.tandberg.net](http://www.tandberg.net))
- V-Tel ([www.vtel.com](http://www.vtel.com))
- Welch-Allyn ([welchallyn.com](http://welchallyn.com))

### C. Additional Support Equipment

1. Fax machines at health care facility and patient facility. These are used to transmit patient information, consents, billing records and other documents.
2. Portable carts so that the equipment can be easily moved. Some facilities are configured so that multiple rooms can be used as telemedicine

locations. This is especially useful when planning to use a large room for distance learning applications and a smaller room for clinical consultations, or multiple, different clinical specialty rooms. Although it is easy to develop a mobile, integrated equipment set, moving it should be done carefully to ensure that equipment reliability remains high.

3. Additional lighting may be needed in order to provide enough light to clearly illuminate the patient.
4. The background walls should be a medium blue color to provide adequate color contrast between the patient or clinician, and the background.

Equipment is also available that allows for a personal computer to be converted into an ITV system. This conversion requires a special computer card that consists of the components of a self-contained ITV system, as well as additional software. This card is inserted into the CPU and contains ports where the peripheral equipment is attached. Some units can also be configured via USB ports. In general, because the computer is not a dedicated ITV system, there is increased potential for additional technical difficulties. Systems of this type are generally being phased out in favor of stand-alone video systems.

## 2. Network Platform

Network platform availability may vary according to geographic location. Note that no matter which platform is chosen, analog POTS (Plain Old Telephone Service) service is still required for the fax machine and for some stethoscopes.

### A. IP (Internet Protocol)

IP, also known as H.323, enables communication over the routed internet. IP networks offer the potential of vastly improving the accessibility of telemedicine, such as desktop availability. However, security and quality-of-service issues related to clinical videoconferencing on the public internet must be considered. One alternative is creating a virtual private network (VPN), which will ensure

dedicated bandwidth and minimal security risk. It is expected that telemedicine networks will eventually migrate to the IP platform, so all equipment purchased should be IP compatible even if IP service is not yet available. This recommendation should not be a limiting issue, because most equipment accommodates both IP and ISDN solutions.

Point-to-Point IP can be created by purchasing T1 or fractional T1 service from a telecommunications provider. This is a simple line with no connection to the rest of the internet or to any other network. It is thus extremely secure from any form of privacy breach. However, routers must be provided at both ends so that the ITV systems can communicate. Connecting additional lines and routers to this initial setup will create a private network that can utilize all of the available bandwidth. Security risks on this type of network are minimal. Other than the monthly fee for the lines, there are no usage fees for connectivity regardless of the available bandwidth that is used. Extra expense is incurred in router maintenance and programming. Although the self-contained network has the advantage of security and privacy, this security also severely limits the ability to connect with any site outside the network. In order to connect outside the network, a “gateway” or “gatekeeper” which connects to the internet or another network must be installed. Connectivity will be increased, but the process of adding a gateway raises the specter of safety concerns similar to simply connecting to the internet in the first place. Furthermore, using the public internet for telemedicine is not recommended at this time due to quality of service and security concerns.

IP (internet protocol) potentially offers greater bandwidth than either ISDN option, and it may be less expensive. Access to IP may be restrictive in rural and underserved areas where phone line dial-up is often the only IP option available. To be effective, a site must have a high speed connection to the Internet or Intranet. The Internet service provider must also deliver a high speed connection for both uploading and downloading. Certain DSL IP options offer bandwidth for

fast downloads, but the upload bandwidth is only minimally better than POTS. Since video conferencing is a two-way interaction, the IP solution must be equally fast in both directions. Additionally, Quality of Service (QoS) is not typically guaranteed when using a public Internet connection via DSL.

#### B. ISDN (Integrated Services Digital Network)

An ISDN, or H.320, service allows a user to send different types of data and messages over varying bandwidth options. To effectively evaluate the different ISDN options, it is important to understand how ISDN compares with POTS:

POTS - single telephone line = 64K

ISDN BRI: 2 channels = 128K (see below)

ISDN PRI: 23 channels = 1472K (see below)

If the local platform is ISDN, a decision may be required between two different types of ISDN lines:

1. BRI (Basic Rate Interface): BRI ISDN operates at 128 Kilobits per second (Kbps)(two 64k channels). This is twice the bandwidth of a standard phone line. It has less bandwidth capacity than the PRI option, but it is also less expensive than PRI.
2. PRI (Primary Rate Interface): PRI ISDN has 23 channels, each operating at 64Kbps. A PRI can provide 11.5 times more bandwidth than a BRI and therefore, the expense is greater. ISDN PRI lines are similar to T1 lines in terms of bandwidth. The end user can typically designate the number of 64Kbps channels (1 to 23) to be used in this environment. The more channels used in a call the greater the bandwidth and the better the picture quality. A 384k call will use 6 of the available 23 channels.

Images transmitted over BRI, or even multiple BRIs, use a lower bandwidth than a full PRI. Picture quality transmitted over BRI may be diminished, particularly when the subject is moving. Movement at lower bandwidths may appear choppy,



fuzzy, or pixilated. PRI solutions avoid this by providing the end user with the option to select additional 64Kbps channels to provide more bandwidth to better handle images of something in motion. Keep in mind, however, that as bandwidth increases so does the cost of the call. PRI calls are often charged at a per minute rate, based on the number of 64Kbps channels used in the call.

### C. Cost-benefit analysis

ISDN offers a dedicated amount of bandwidth, but it comes with a monthly fee and a per minute usage fee if long distance calls are made (currently, TeleKidcare uses only local calls). If a site is making a great number of calls, the usage fees will increase accordingly. IP also has a monthly fee, but in many cases there is no usage fee for the calls. If both IP and ISDN are available, comparing the monthly fees, plus the usage fees, based upon the expectation of usage is the best way to determine which method is most cost beneficial.

Usage fees are difficult to estimate because they are dependent upon many variables. Most telecommunication line providers have a rate schedule that calculates calls based on bandwidth, or channels used, and the destination of the call, be it interstate, intrastate, interLATA, or intraLATA. Contacting local telecommunications providers for pricing structures is recommended.

### D. Operational

Start-up – The First 30 days

#### Reconfirming School District Board of Education (BOE) Approval and Developing Consent Forms:

- Although BOE approval is actually done at the earliest stages of project planning, at this point, there is wisdom in reconfirming approval with the members as well as briefing them on the progress of the project and the projected implementation date.

- Take time with the consent form to do it right the first time. Work with legal staffs of the school district and the health care provider; develop a project consent form. Please note that this process can be very time consuming.
- Make certain to include appropriate HIPAA language.
- Begin any Human Subjects or Internal Review process that may govern the project.

#### Deploying the Technological Infrastructure:

- In rural areas, submit Universal Service Fund applications to the Rural Health Care Division of the Universal Service Administrative Company (if applicable).
- In urban or suburban communities, encourage schools to research the possibility of incorporating telemedicine communication costs into the district's e-rate application.
- Get multiple bids on equipment and telecommunication costs.

#### Meeting and Interacting with the Site Personnel:

- Identify the location of the telecommunications closet or room at the site. A technician or custodian may be able to help with this process.
- Identify the room that will be used as the telemedicine room.
  - This is often the schools nurse's office or health room.
  - The room should offer privacy, security, and confidentiality.
  - It must have adequate lighting.
  - The room should be able to accommodate up to 3 or 4 participants sitting in front of the ITV system.
  - In older buildings, consider accessibility of electrical outlets
- Modify the room for telemedicine
  - The wall opposite the monitor should be relatively clutter-free.
  - The background wall should be painted a medium blue color to aid in the transmission of skin tones and picture clarity.
  - It is helpful to have a moveable cart for the equipment

- 
- Determine who will be responsible for bringing the telecommunications wiring into the telemedicine room – either the telecommunications installers or the school district technical staff.
  - Discuss procedures and expectations for logistics of scheduling, billing, reimbursement, evaluation, consent, and other administrative issues.
  - Begin training process with providers and school nurses.
    - Develop a training manual.
    - Make arrangements for school nurses to shadow the health care provider in the clinic setting in the specialty medical center.
    - If possible, arrange for school nurses to visit with other school nurses who are experienced telemedicine users.
    - Training must be on-going!
    - Encourage those who will be operating the ITV systems to practice frequently.
  - Educate the community
    - Demonstrate the equipment any time possible such as back-to-school nights, open houses, or conferences.
    - Ask small groups of staff to observe the capabilities of the equipment.
    - Send brochures or flyers home with the students.
    - Visit with the parent-teacher organizations and emphasize the importance of access to health care.
  - Once the network is up and functioning, it is wise to observe the process and determine if changes or modifications need to be made.

Work with School Health Professionals to Develop Clinical Protocols.

Bid equipment if necessary.

Develop evaluation tools if they are not already in place.

## **The 31 to 60 Day Start-up Window**

Complete procedures for billing, reimbursement, and scheduling.

Order telecommunication service:

- In some rural communities, installation of the telecommunications lines integrates the services of several companies; therefore, the process can be quite lengthy. Allow at **least** 30 days for this process to be completed.
- Be certain to provide the telecommunications provider with the contact information of the contact person at the site.

Order Equipment:

- Inventory equipment as it is received.
- Test equipment to make certain it is ready to be installed.

Make Certain Evaluation Tools are Being Developed or are Ready.

Make Required Changes to Telemedicine Room(s).

## **The 61 to 90 Day Start-Up Window**

Installing Equipment:

- Make certain telecommunication lines are functioning.
- Test equipment and all network connections.
- If available, enter frequently called sites into the videoconferencing system or store and forward system address book.

Continue Hands-on Training with the Users:

- Practice making calls.
- Practice migrating to different cameras or peripherals.
- If part of the project, practice attaching a variety of peripherals to the equipment.

- Investigate first hand the capabilities of the system.
- Conduct mock consults and encounters.
- Encourage all users to use the equipment in some fashion every day.

Finalize Logistics of Scheduling, Billing, Reimbursement, and Other Issues.

Contact Media to Assist in Educating the Public Regarding the Availability of School-based Telemedicine and Its Capabilities.

### **The 91st Day**

It's time to begin – establish a start date for the telemedicine clinic.

Continue to make adjustments and refinements.

Begin collecting data.

## **IV. Lessons Learned from the Field**

### ***A. The support and active participation of the school nurse is critical.***

A school nurse who empathetically understands the plight of the surrounding community and embraces school-based telehealth as a mechanism to bring needed health care to children represents the crucial element to the development of a successful program. As the initial health care contact with a student, the school nurse performs the assessment and guides the decision-making process regarding the appropriate course of action. The school nurse refers for the telemedicine visit. In essence, the school nurse becomes a health care advocate for the student.

### ***B. Open and direct communication between the school nurse and health care provider is critical and cannot be taken for granted.***

Prior to the initiation of services, expectations should be discussed and understood by both the physician and school nurse. During a telemedicine consult, a high level

of trust, confidence, and open communication between the two participating health professionals produces an environment that allows the focus of the encounter to remain on addressing the health care needs of the child. Mutual trust and respect must be paramount, as the school nurse functions as the hands of the physician during the consult.

***C. Health care providers must be flexible in their approach to the telemedicine clinic visit.***

Physicians may feel as if they are relinquishing partial control of the consult as they depend on the assessment and communication skills of the school nurse. Physicians report that they rely heavily on the medical history and physical assessment provided by the school nurse when determining a diagnosis. In addition, some health care situations are not appropriate for telemedicine. Some rashes are difficult to diagnose in person, and therefore can be difficult to diagnose via telemedicine. At times the advocacy role assumed by the school nurse entails taking advantage of the expertise and authority status of the physician to provide sufficient motivation for some parents to seek care for their children.

***D. The role of the school nurse is enhanced and expanded with the addition of school-based telehealth.***

Not long ago, the responsibilities of the school nurse were limited to state mandated vision and hearing checks, updating immunization records, and dispensing band-aids as needed. Now, telemedicine physicians state that one of the advantages of the TeleKidcare encounter is the presence of the school nurse. The school nurse serves as an additional support person of the physician, the patient, and the patient's family. For example, during a telemedicine visit, the otoscope used by the school nurse displays a magnified view of the child's auditory canal on the monitor. The parent and child can actually see the bulging tympanic membrane indicative of otitis media. It is readily apparent to the parent and child why an ear infection can be so painful. The effect of this presentation is a valuable tool: not only does it

serve as an educational demonstration of the structure of the inner ear, but the visual impact functions as a motivating reminder of the need to comply with the medication orders given by the physician.

***E. The technology is generally very reliable.***

With each passing year, technology has provided an increasingly reliable ITV product. As these products are coupled with improvements in the telecommunications network and support system, the quality of the ITV transmission is enhanced. Additionally, costs have diminished dramatically even during the past five years. What once cost over \$100,000 is now below \$16,000, while providing a higher quality image and transmission reception. This cost includes the CODEC, monitor, and medical peripherals required for a school-based service (See Attachment C).

***F. One central partner should assume the overall coordination of the project.***

At first glance, school-based telehealth appears to have only two major components: the school nurses and the health care providers. However, the third member of the school-based team cannot be overlooked. The overall coordination, logistical, and support duties of the project should be assumed by one central partner.

Responsibilities might include diverse activities such as ordering equipment, developing scheduling protocols, trouble-shooting technology concerns, producing informational and publicity aids, implementing research opportunities, completing grant proposals, creating long-range goals, facilitating meetings with school nurses and physicians, and other tasks as needed.

***G. Experience with TeleKidcare in an urban setting indicates that highest usage will come from elementary schools. In addition, when the participation rate in the Federal Free and Reduced Lunch Program is elevated (75 % or above), the number of consults tends to increase.***

Elementary school-aged children are more prone to present with acute health care concerns that can be diagnosed via telemedicine (e.g., otitis media, strep infections, respiratory ailments, or rashes). Middle school and high school usage with TeleKidcare is most often limited to behavioral health care consults. When family economic resources are limited, routine health care, because of its expense, is often neglected. Since participation in the Federal Free and Reduced Lunch Program is tied to family size and economic resources, high rates of participation can indicate that a low-cost or no-cost health care project will be widely used. Experience with telemedicine in rural locations reveals that geographic barriers (physical distance separating homes, schools, places of employment, and office or clinic of health care providers) make telemedicine an attractive option for health care delivery.

***H. In most communities, the neighborhood school is perceived as a safe and nurturing environment for children.***

The neighborhood school is a place where students are supported and families meet and gather. It is a place of immediate acceptance where the staff and faculty actively seek to meet the needs of students regardless of socio-economic condition, language barrier, cultural affiliation, or citizenship status. Many already know and trust the school nurse. A doctor's office can be somewhat intimidating in comparison. This increased level of comfort allows patients and parents to confide important information that they may not have been willing to express in less comfortable surroundings

***I. School-base telemedicine provides a gateway to connect families to health care services.***

Easing the entry into the health care system is a natural extension of the role of the school nurse. Telemedicine is an effective tool to assure that a sick child receives necessary health care while introducing families to health care providers in the community. The school nurse also models effective interaction with a physician. Often parents feel uncomfortable in the presence of an unfamiliar health care



provider and questions that need to be voiced are never asked. The school nurse is skilled at facilitating the discussion that needs to occur between patient and provider.

**J. Telemedicine can be used to provide education programs and to support research opportunities.**

At the personal level, the telemedicine consult provides an excellent forum for a physician to share critical information with the entire family about a pertinent chronic ailment such as asthma, diabetes, or allergies. At the building level, school-based telemedicine provides an avenue into the schools for health care organizations and establishes a helping, trusting relationship for other supporting and educational partnerships. Schools are able to access the health care organizations for their expertise on a multitude of health-related topics. Health care organizations can work with the school district to develop wellness programs, special immunizations clinics, or other beneficial projects.

## V. Useful References

<sup>1</sup>Committee on Evaluating Clinical Applications of Telemedicine. *Telemedicine: A guide to assessing telecommunications in health care*. Washington, DC: National Academy Press, 1996.

<sup>2</sup>Doolittle GC, Williams AR, Cook D. An estimation of Costs of a Pediatric Telemedicine Practice in Public Schools. *Medical Care* 2003; 4:100-109.

<sup>3</sup>Whitten P, Cook D, Shaw P, Ermer D, Goodwin J. TeleKidcare®: Bringing Health Care into Schools. *Telemedicine Journal* 1998; 4(4): 335-343.

<sup>4</sup>Nelson EL, Shaw P, Doolittle GC, Peacock G, Cook D. Telemedicine Provider Perceptions of Diagnostic and Treatment Efficacy in a Pediatric Population [Abstract]. *Telemedicine Journal and e-Health* 2001; 7(2):188.

American Medical Informatics Association  
<http://www.amia.org/>

American Telemedicine Association  
<http://www.atmeda.org/>

Association of Telemedicine Service Providers

<http://www.atsp.org/>

Healthcare Information and Management Systems Society

<http://www.himss.org/ASP/index.asp>

International Society for Telemedicine

<http://www.isft.org/>

National Telecommunications and Information Administration

<http://www.ntia.doc.gov/>

Office for the Advancement of Telehealth (OAT)

<http://telehealth.hrsa.gov/>

Office for the Advancement of Telehealth Technical Guidelines (Teledermatology)

<http://telehealth.hrsa.gov/pubs/tech/derm.htm>

Telehealth Deployment Research Testbed (TDRT)

<http://tdrt.aticorp.org/>

Telemedicine Information Exchange

<http://tie.telemed.org/>

Universal Service Administrative Company (USAC)

[www.universalservice.org](http://www.universalservice.org)

## **VI. Sample Clinical Protocol**

### Protocol for Child Presenting with Asthma

1. Stop any activity student is performing. Rest and calming can avert a major asthma attack.
2. Allow student to assume a comfortable position with head and chest elevated.
3. Allow student to use inhaler as directed.
4. Encourage student to take sips of tepid water if tolerated. Do not force.
5. Have an approved person give medication, if on hand, as prescribed.
6. Follow instructions in health record given by the family physician.
7. Keep student in the health office until there is relief of symptoms or other action is taken.

8. If breathing does not improve in 10 minutes after using an inhaler or administration of other medications, call parent and advise physician's care or offer telemedicine
  - a. If offer of telemedicine is accepted, begin scheduling process
  - b. Gather student recent medical history from parent
9. If student improves and is able to return to class, be certain to advise school administration and parent of the asthma attack and any medication given.
10. If student is breathing more than 45 breaths/minutes, has abnormal color (pale, dusky, or blue), seems less alert, or is unable to speak at least two words between breaths, CALL 911 – NOTIFY PARENTS.

#### Protocol for Child Presenting with a Sore Throat

1. Determine if cause is viral or bacterial
2. Consider bacterial if:
  - a. sudden onset
  - b. sore throat and tonsils
  - c. fever
  - d. headache
  - e. nausea, abdominal pain (occasionally vomiting)
  - f. marked inflammation of pharynx and tonsils
  - g. tonsillar hypertrophy with white exudates
  - h. tender, enlarged cervical nodes
  - i. absence of conjunctivitis, coryza, cough, diarrhea
3. If the child has a fever, contact parent and advise physician's care or offer telemedicine consult.
  - a. If the parent agrees to the telemedicine consult
    - perform a rapid strep test
    - proceed with routine process to schedule a telemedicine visit
  - b. If the parent does not want to schedule a telemedicine visit, ask the parent to make arrangements for the child to return home and again, advise physician's care.
4. Remind parent that child should not return to school until they have been free of fever for 24 hours.

## Attachment A

### School-based Telehealth Success Stories

#### **Previously undiagnosed acute asthma attack**

Her son was “breathing funny.” In fact, he had been up all night. Even though his mom had called a nurse information line she was not relieved or assured by the information that she had received.

The first thing the next morning, the mother called her son’s school nurse. Her son had been seen many times at the school-based telemedicine project by the child psychiatrist for ADHD. The mom asked the school nurse if her son could be seen this morning for his medical concern.

As the school nurse called to schedule a telemedicine consult, the mother and son hurried to school. Shortly after arriving at school, the student was being examined via telemedicine by a pediatrician in the Kansas University Medical Center pediatric clinic. The physician was troubled and alarmed by what he heard over the stethoscope. He advised the student’s mother to bring her son immediately to the clinic.

After a quick cab ride to the hospital, the student was immediately placed into the ICU for an acute asthma attack. Prior to this incident, the student had no history of asthma. Because of the family’s familiarity and trust of telehealth, the student was immediately seen, diagnosed, and treated for a potentially dangerous medical situation.

#### **Baby brother**

A school nurse involved in the school-based project received a telephone call from one of the school’s fifth grade students after school one day. The student’s mother had recently given birth to a baby boy, and the area around his umbilical cord was red and “puffy,” according to the student. The fifth grader had been examined by a physician through the telehealth project on a different occasion and thought that her new brother could receive health care services in the same manner for his condition. In light of the fact that the student’s mother did not speak English and did not have access to health care services, the school nurse asked the student to have her mother bring the baby to the school so the nurse could examine him.

The school nurse arranged for an interpreter to be present when the mother arrived with her newborn. After doing a physical assessment, the school nurse discovered that the baby’s umbilical cord was infected, and that the baby needed medical treatment. While the situation was not appropriate for an actual telemedicine encounter – given the newborn’s age and fragile state – the circumstances illustrate the fact that clinical applications of telemedicine provide additional benefits to users by educating them about accessing much-needed health care and by offering them resources for navigating through the health care system.

**An ear infection gone bad**

Early on a Monday morning, a teacher brought a 1<sup>st</sup> grade student to the school nurse at a school with telehealth capability. The teacher explained that the little boy had a bad earache. The family did not speak English so, with the assistance of one of the school's interpreters, the school nurse called the mom (who had just had a baby) to ask about arranging a telemedicine visit. The nurse also took the boy's medical history. Mom consented, but could not attend the visit due to the new baby; an aunt came instead. While gathering the boy's recent medical history from the mother, the school nurse learned that the little boy had had an earache for some time. In fact, he had been seen two weeks ago for an ear infection. At that time, he had been given a prescription for amoxicillin.

That day, the first grader had a temperature of 100° F.; he was pale and very uncomfortable. Using the regular otoscope, the school nurse could see in the boy's right ear but could not get a clear picture of the left one. Everything was white; the school nurse assumed it was from an infection. In addition, there was swelling and significant tenderness behind his left ear. The student tested positive for strep.

The visit with the pediatric resident began at 1:30 PM. Using the digital otoscope, the school nurse was still unable to get a clear picture of the student's left ear. The school nurse's concern for the student was fueled by two circumstances: the intensity of his pain and the unusual nature of what could be seen, or not seen, by the otoscope. The pediatrician considered prescribing Augmentin for the student. However, the pediatrician knew that the school nurse was uncharacteristically alarmed about the student's ear and the associated pain. Because of the school nurse's concern, the pediatrician took another approach.

At the pediatrician's suggestion, the interpreter asked the student's aunt if she could get him to clinic. Because neither the aunt nor the student spoke English, the school nurse wrote a message on the back of the map that she had given them explaining that the pediatrician had asked that the student come to the clinic right away.

Upon his arrival at the clinic, an ENT team assumed responsibility for the boy's care. After ruling out mastoiditis, a diagnosis that would have meant probable surgery, a course of powerful antibiotics was prescribed to combat the severe ear infection. The student spent one night in the hospital as his situation stabilized. The next day with the aid of the interpreter, the student's mom told the school nurse that he was finally beginning to smile again.

This story also illustrates the way that telehealth is changing the role of the school nurse. The pediatrician trusted the school nurse's judgment. He knew she was concerned about the student's ear. The professionalism and experience of the school nurse played an important role in the assessment. It is this type of teamwork and trust that has allowed telehealth to become more than just technology but an effective delivery system for health care.

**A suspicious feeding tube**

A school nurse was in daily contact with a particular student who receives nourishment through a feeding tube. When observing the deteriorating condition of the skin surrounding the feeding tube, the school nurse became concerned.

The nurse contacted the parent to voice her concern. The parent shared that the surgeon was planning to replace the feeding tube in three or four months. The school nurse accepted the parent's answer but remained apprehensive about waiting a minimum of three full months for the procedure to be done.

When the student began to run a low-grade fever, the school nurse's fear escalated. She contacted the parent again, this time suggesting that the child be seen over telehealth. The telemedicine physician could examine the area and offer an opinion. The mom agreed.

Prior to the consult, the school nurse brought the student to her office. She carefully unstrapped him from his wheelchair and positioned him on the small examination bench in her office. The student's mother worked nights and was unable to attend the visit, but the school nurse had made arrangements to call her at home so that she could participate in the visit over the phone.

Using the otoscope, the school nurse showed the physician the affected skin around the tube. The physician concurred with the school nurse. The situation was not right and would not improve until the feeding tube was replaced. Waiting three more months for this procedure would not be in the best interest of the child.

Armed with the assurance that this was not a frivolous concern, the mom contacted her son's surgeon. As a result, the student was seen the very next day. The procedure that was supposed to have waited for at least three more months was done within days. The student was back in class without having suffered any major repercussions from a situation that could have become quite serious.

**Comments About TeleKidcare®**

"If TeleKidcare was no longer available at this school, most of these parents just wouldn't take their kids to the doctor because many of them are undocumented and they are afraid to go the doctor. Most would just end up at the emergency room."

-The Parent Liaison at a TeleKidcare School

"My child was having behavioral problems in class. His teacher insisted that he be seen by a doctor, but I called and couldn't get an appointment for months. The TeleKidcare doctor was able to see my child the next week."

"TeleKidcare is great because I don't have transportation to take him to a doctor, and there are no doctors close by."

“I love TeleKidcare because I know that if the school nurse says the appointment is at 1:30, then I won’t have to wait...we used to have to wait at the clinic for two or three hours.”

# Attachment B

## School District SCHOOL-BASED TELEMEDICINE SERVICES

### Permission for Services

Student Name \_\_\_\_\_ DOB \_\_\_\_\_ SSN \_\_\_\_\_

I am the parent or lawful custodian of \_\_\_\_\_. I give consent for my child to be assessed/evaluated/treated in the School Bases Telemedicine program managed by the school nurse. On site consults or evaluations may be provided through telemedicine linkage \_\_\_\_\_. At no time will my child be transported from school premises for evaluation or treatment without my express consent. I understand that every attempt will be made to contact me or our emergency contact in the event my child becomes ill or is injured at school, and that school nursing services will never be denied due to lack of insurance coverage. I understand that I may contact the school nurse or the appropriate clinic if I have any questions or concerns.

I give consent for the following physical and/or mental health services to be performed in the school health room managed by the school nurse, and through the school based telemedicine program:

- Treatment of my child in the school health room if a parent/lawful custodian cannot be present
- Diagnosis and treatment through telemedicine linkage and by protocol of health problems (stomach aches, earaches, headaches, cuts, sores, colds, coughs, rashes, sore throats, etc.)
- Routine laboratory work (rapid strep tests, etc.)
- Psychiatric/psychosocial evaluation/treatment regarding problems at school and/or home (only with parental participation)

**Release of Information:** The information in my child’s medical record is confidential and will not be released to any unauthorized person or agency without my consent. I authorize the school nurse to disclose all or any portion of my child’s medical record to his/her primary care provider and other school based telemedicine program staff. The school based telemedicine program staff may review my child’s school records, and other school information that may assist then in helping my child. I understand that data from my child’s telemedical consults may be utilized anonymously for research purposes, and that information about my child, family, and school—including identity, will never be disclosed in any form in any publication. I understand that this telemedicine encounter may result in my Protected Health Information (PHI) being retained and used, as described by federal HIPAA (Health Insurance Portability & Accountability Act) regulations, and those various HIPAA regulations pertaining to this PHI may become applicable. The interactive tele-video equipment and telecommunications lines in the school based telemedicine program consultation are HIPAA approved for patient security and privacy.

**Billing authorization:** Because the school based telemedicine program is a school service, parents or students will never be assessed an out-of-pocket fee. Services available through school based telemedicine program are possible, in part, through the technology available through \_\_\_\_\_. This agency is able to bill Medicaid and most insurance for an office visit if your child is seen through the use of this technology. The school district is able to bill Medicaid for nursing services related to the telemedicine visit. No charge is ever assessed for routine hearing and vision screens or health assessments required by law, or for routine visits to the school nurse managing the center. No child shall ever be denied services, including access to telemedicine consults when appropriate, due to inability to pay.



To assist in providing services and in insurance billing, I agree to provide copies of my child's insurance/medical card and other information concerning health insurance as may be requested by school based telemedicine program staff. I also authorize disclosure by school based telemedicine program staff of all or any portion of my child's medical record to any authorized person for the purpose of recordkeeping, billing, or verification of my child's medical insurance coverage or medical care benefits.

**This consent is in effect until is revoked in writing by me. I understand that it is my responsibility to notify the school about changes in guardianship.**

Signature of lawful custodian \_\_\_\_\_ Date \_\_\_\_\_

Home Address \_\_\_\_\_ Hm Phone \_\_\_\_\_ Wk Phone \_\_\_\_\_

Insurance Information \_\_\_\_\_ HMO \_\_\_ PPO \_\_\_ EPO \_\_\_ Medicaid # \_\_\_\_\_

## Attachment C

### Originating Site Costs

#### **Equipment**

Equipment for each school site: Approximately \$16,000

- Interactive Televideo System
- Digital otoscope and integrated light source; the integrated light source or light platform supplies light to the peripheral's (otoscope, dermascope, etc.) camera and delivers the image to the monitor
- Analog stethoscope – sending
- Fax machine

#### **Personnel**

School Nurse

### Distant Site Costs

**Equipment:** Approximately \$9,000

- Interactive Televideo System
- Analog stethoscope – receiving
- Fax machine

#### **Personnel (current TeleKidcare personnel; program needs will vary)**

Clinical Director (5%)

Director of TeleMedicine (5%)

Assistant Director of TeleMedicine (5%)

Consulting Physicians

Scheduler (50%)

Project Manager (100%)

Technician (50%)

Researcher (50%)

#### **Overhead**

Office Space

Utilities

Office Supplies

---

## Attachment D

### Memorandum of Agreement

The following Memorandum of Agreement between \_\_\_\_\_ and \_\_\_\_\_ covers the primary areas of responsibility of each party regarding the school-based telemedicine program.

The coordinating provider organization will:

*Equipment and Supplies*

- Purchase and set up ITV equipment for the School Health Office; equipment will be ordered once the date for the initial training of the school personnel has been established.
- Work with phone companies to establish ISDN and analog connections necessary for the program
- When presented with the proper forms, reimburse school district for phones lines associated with project
- Provide Rapid Strep Tests
- TKC equipment remains the property of KUMC

*Training, Education, and Research*

- Provide ongoing training for school personnel regarding the ITV equipment.
- Provide education regarding the telehealth program for faculty, administration, staff, and patrons
- Engage interested schools in various research projects as they are available.

School Districts agree to:

*Equipment and supplies*

- Provide appropriate space for telehealth equipment
- Keep equipment safe and secure
- Provide miscellaneous supplies such as covers for otoscope and paper and ink for fax machine
- Pay phone bills and submit paperwork to the coordinating organization for reimbursement

*Training and Research*

- Provide designated school personnel time for training at the school site and with the local health care provider
- Provide various opportunities for telehealth representative to provide information to faculty, administration, and community about the project
- Maintain medical records
- Complete research forms

## Attachment E

### Parent/Guardian Survey (Sample)

Date \_\_\_\_\_

***I. Please tell us something about YOURSELF:***

Your age \_\_\_\_\_ Your gender \_\_\_\_\_ Ages of your other children \_\_\_\_\_

Your Ethnic Background (*check all that apply*):

- White (non-Hispanic)
- Black (non-Hispanic)
- Hispanic
- American Indian
- Asian / Pacific Islander
- Arab
- Other \_\_\_\_\_

What is your relationship to the student? \_\_\_\_\_

***II. Please tell us something about the GENERAL HEALTH of this student:***

How would you describe the general health of this student?

- Poor
- Fair
- Good
- Excellent

During the previous 12 months, approximately how many total days of school has this child missed due to illness?

- Has not missed any days of school due to illness
- 1-3 days
- 4-6 days
- 7-9 days
- 10 days or more

The last time your child was sick and had to miss school, where did he or she receive medical care?

- My child did not need medical care at that time – I allowed my child to stay home until he/she got better
- At the School Nurse’s office through telehealth
- At our primary care doctor’s office
- At the Community Clinic
- At the County Health Department Clinic
- At the Urgent Care Center
- At the Emergency Room
- Other – *please specify:*

**III. Please complete the following questions AFTER the visit has been completed.**

Including the telemedicine visit, how much time did you spend at the school today?

- Less than 15 minutes
- 15 – 30 minutes
- 30 – 45 minutes
- 45 – 60 minutes
- Over 60 minutes

Please indicate your level of agreement with the following statements:

	Disagree	Somewhat Disagree	Not Sure	Somewhat Agree	Agree
The physician listened to my questions and concerns.					
I was adequately informed about the issues important in treating my child.					
The physician explained the treatment plan					
The physician encouraged me to talk during the visit.					
I was satisfied with the physician’s “bedside manner.”					
The physician <u>DID NOT</u> allow me to thoroughly explain my child’s condition.					
The physician was competent.					

How would you rate your satisfaction with today's telehealth visit?

- Very dissatisfied
- Dissatisfied
- Somewhat dissatisfied
- Somewhat satisfied
- Satisfied
- Very Satisfied

How would you describe the quality of service received from telehealth compared to the quality of service that you would have received at another healthcare facility?

- Not as good
- Just as good
- Better

*Why?*

***Thank you for taking time to complete this survey.***

## Telehealth Technology

**Authors:** Franklin D Gannan, University of Missouri Health Care  
Richard Phillips, St. Claire Regional Medical Center  
Michael Patterson, University of Virginia

### Contributing Editors:

Samuel Burgiss, PhD, University of Tennessee  
David Batton, CCNA, University of Virginia  
Bryan Nation, Banner Healthcare  
Rob Sprang, MBA, University of Kentucky  
Joseph Tracy, MS, University of Missouri Health Care

### I. Introduction

The following information is being provided as a means to assist individuals in understanding the basic design or technical configuration of a telehealth network. These guidelines are based on the experience of operational telehealth/telemedicine programs throughout the United States. This work is designed to work in conjunction with the previously developed Telehealth Technology Guidelines published on the Office for the Advancement of Telehealth web site <http://telehealth.hrsa.gov/pubs/tech/techhome.htm> (accessed on 6/8/04).

The authors also highly recommend that a team approach be used to design a telehealth network. That is, anyone embarking upon the development of a telehealth network should include information technology staff and telecommunications staff, as well as the telehealth staff. If a cohesive and productive relationship can be developed among these three groups the development of the network will be more widely accepted and embraced.

This chapter mainly addresses broadband interactive video telehealth technologies and networks because they are generally more complex in design than store and forward (S&F) or technologies using plain old telephone service (POTS). It will provide an understanding of the basic technology and a common core set of standards that can be applied to telehealth applications. This chapter will primarily address the following four aspects of a telehealth program technology implementation plan.

- Networks
- Network Equipment
- Telehealth Equipment
- Room Evaluation

When reviewing the information contained in this chapter please note the following:

- The statements made are not an endorsement of any technology, vendor, or product. They simply provide information on the technology specifications that the developer of a telehealth network should consider.
- If you have questions regarding the meaning of various telehealth technical terms, see Appendix A – Telehealth and Telecommunication Definitions.
- All equipment evaluations are subject to clinicians utilizing the technology. The clinician must always feel comfortable with the technology implemented.
- The standards are based on existing practices which utilize telehealth technologies.

It is critical in the early development of a telehealth Network that one gains a basic understanding of current technical standards, while maintaining focus on key issues that will provide more efficient network design. Below are five areas that should be considered when looking at any telehealth technology.

### **1. Compatibility**

Not only should the technologies be compatible in terms of interoperability, but newer versions of technology must also be compatible with earlier versions of a similar



technology. Whenever possible, the purchaser of telehealth equipment must ensure, to the best of their ability, that the vendors selected will provide some commitment to planning and developing new technologies that are compatible with previous versions of their equipment. This type of commitment decreases the likelihood of rapid product obsolescence.

## **2. Interoperability**

In order to develop telehealth networks that interface with one another and create an open environment that can share the national information infrastructure, one should strongly consider the purchase of technologies that meet the recommended guidelines provided within this document.

## **3. Scalability**

Technology purchased for telehealth should be capable of migrating into expanded capabilities without total replacement. For example, if there is high probability that a move from 128 Kbps (kilobits per second) to 384 Kbps of bandwidth will be required at some point, then it would be a mistake to purchase equipment that would only operate at 128 Kbps. Rather, the correct choice would be a unit that would work at both 128 Kbps and 384 Kbps. Additionally, features and functions should be available as options rather than impacting the base cost of the technology. Various instruments for patient examination should be added to the base system as needed by the clinical applications being provided at each site.

## **4. Accessibility**

The level of the vendor's accessibility in terms of sales, timely delivery, and equipment maintenance should be a purchasing/selection criteria.

## 5. Reliability

Telehealth programs should consider issues such as the reliability that the network and equipment will work consistently as intended and that the technologies can be reliably serviced with minimum downtime.

## II. Networks

This section will describe a typical telehealth network and the equipment that is required for a basic network configuration.

The definition of a network is “a connection of related items”. No matter what is being connected together, it is a network. When trains connect with tracks and train stations, a train network is created. If planes connect with flight routes and terminals, a plane network is created. If computers are connected together with wires, hubs, switches and routers, a computer network is born.

There are two basic types of networks. These are wide area networks (WAN) and local area networks (LAN).

A WAN, or Internet, connects LANs to other LANs so they can communicate. This is accomplished using wired or wireless telecommunication connections and a device known as a router (see Appendix A). Information on routers is discussed later. When a WAN is drawn in a network diagram, it is usually drawn as a cloud (Figure 1).

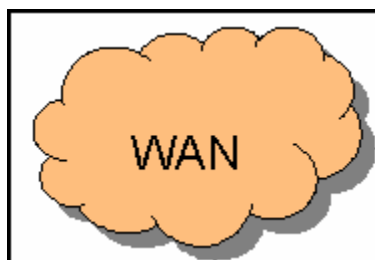

Figure 1

---

There are two reasons why a WAN is diagramed in this manner. First, a WAN is typically the responsibility of a telecommunications carrier and typically not controlled by the organization. Second, a WAN is complicated in that it has a great deal of equipment working to transfer information from one point to another. The telecommunications provider maintains the equipment and it is up to them to make sure the information is being sent and received properly to the DEMARC point. We will discuss what a DEMARC is in the *Understanding Network Equipment* section of this document.

LANs are typically, but not always, a computer network contained within a building or a single organization. Also known as an Intranet, a LAN connects computers in a building together so they are able to communicate with each other and other computer based equipment such as printers, servers, and routers.

What is the Internet? A misconception is that the Internet is a single entity. The Internet is actually a collection of LAN's connected to WAN's. When accessing a web page on the Internet, a computer, on a LAN, sends out a request to a device on another LAN to send information back to the originating computer. An example of this would be, if one were to open a web browser on a computer and enter [www.search.com](http://www.search.com) in the web browser address box and press the **ENTER** key, the computer sends a request to a server located in San Francisco, Ca. The server in San Francisco then sends information the originating computer needs to display on its screen. The computer and the server located in San Francisco are both on their own LAN and they are able to communicate with each other via a WAN connection.

Since WAN connections are phone lines typically leased from the telephone company (Telco) or other internet service provider (ISP), the applications one will be using may determine what kind of WAN connection will be needed. The following are some of the most widely used communication methods for telehealth networks.

1. **T1:** is digital telecommunications connection running at 1.544 megabits per second. T1 services can be provisioned to use various communication protocols (e.g., Frame Relay, ATM, etc.). If ordering T1 service, be prepared to specify

how the line should be provisioned (voice grade, frame relay, etc). The telecommunications provider may also provide networking recommendations for this type of line.

2. **Integrated Services Digital Network (ISDN):** is a broadband dial-up digital WAN connection that uses a series of channels capable of carrying data from one point to another. ISDN comes in two varieties: ISDN-BRI and ISDN-PRI (see Appendix A).
3. **Digital Subscriber Line (DSL)** is a type of broadband connection with a constant connection. It can be purchased in different varieties – ADSL, SDSL or HDSL. DSL can provide medium upload and high download speeds as typically found in the home, or it can be configured bi-directionally at the same speed. Costs will vary depending on the service selected.
4. **Plain Old Telephone Service (POTS):** This is the type of service used for most home telephone connections and dial-up Internet connections. Although POTS lines are provisioned for 64 Kbps of bandwidth, connections are rarely above 33Kbps and in most cases never above 45 Kbps. A POTS connection works well for store and forward telehealth (e.g., home monitoring equipment, digital pictures) and it can support POTS based video connections to reach areas where broadband is not available.

It should be noted that not all WAN connections are the same. The reliability and service level is heavily dependent upon who is actually managing the WAN and the network equipment.

**Private Networks** are designed for the use of a specific organization or company. The networks can use dedicated connections that are always on and ready for use, or they can use dial-up services that connect certain network devices. Depending on the telecommunications provider, factors such as constant bandwidth of the WAN connection and quality of service (QoS) may be guaranteed. **Bandwidth** is how much

data a connection can carry at one time. Guaranteed bandwidth means that the capabilities of the WAN connection will not change. **QoS** on the other hand allows certain types of data over a network connection to have priority over other types of data in an effort to guarantee a certain level of connection quality. For example – in an Internet Protocol (IP) network the audio and video data packets associated with videoconferencing can be “marked” for priority over all other data traffic (e.g., e-mail, file transfers). This priority method helps ensure the quality of the videoconference. QoS is generally available only in private or virtually private networks.

A **Public Network** connection is a WAN connection shared by others. Public connections usually include internet connections that are used in the home. These shared connections are usually dial-up, DSL, or cable connections. The bandwidth on a public connection is shared by a number of people with little or no guarantee of QoS. If one person on the connection is downloading a large file, it could possibly interfere with the information someone else may be trying to send or receive on their connection. Also, information coming into the network may be at a different speed than information leaving the network.

### **Ordering a Network Line**

When ordering a network line from a phone company or service provider, some of the information needed to be supplied will be dependent on the company and type of service chosen. There is however some basic information that will need to be provided no matter what services are ordered.

The basic information that any phone company will need when ordering a network connection would be:

1. Type of service (i.e. Frame Relay, ATM, ISDN, etc.);
2. Required bandwidth (i.e. 56 Kbps, 64 Kbps, 128 Kbps, T1, etc.);
3. Address of the building where the installation will occur;
4. Desired and specific location of the smart jack box (DEMARC). [Specify the room location, the wall (e.g, north), and where the jack should be mounted];

5. Provide the name of a person to contact and their contact information in case the phone company has any questions regarding the installation; and
6. Requested date of installation. Be aware that a network line can take some period of time to install. Many things can factor into installation time such as location of the site, the company that will provide the service, the number of telecommunication carriers involved in the circuit, and the paper work involved.

When ordering a particular type of service, such as frame relay, one should also specify a **Committed Information Rate (CIR)**. CIR is a guaranteed amount of bandwidth provided by the phone company or service provider. It guarantees that the bandwidth availability never falls below a certain amount and is always there when needed. For example, if one specifies a CIR of zero when a line is ordered, it will save money but provide no guarantee by the phone company that any information will make it to its destination. On the other hand if a 128 Kbps line is ordered with a CIR of 128 Kbps, then the phone company will guarantee that as long as the data being sent does not exceed 128 Kbps of bandwidth, it will make it to its destination.

Addressing will also be an issue when ordering a network connection. In order to properly send data to a destination or receive data to one's equipment, the equipment will need to have an address. Just like your house has an address. If a Frame Relay service is ordered, a block of Internet Protocol (IP) addresses will be needed from the service provider in order to assign addresses to the network equipment. If ordering an ISDN line a block of ISDN numbers will be needed in order to dial a connection to and from the equipment. In any case, one will need to let the service provider know how many addresses will be needed for the equipment that will be connected to the network.

After all the details have been worked out, the phone company or service provider should be able to install the line. The department ordering the service will also want to know the cost for the installation of the line, the recurring cost of the line, the date of the installation, an estimated time of the installation, the IP addresses or ISDN numbers made available for the network equipment and any associated cost for those addresses or numbers.

*When ordering any type of telecommunication service the customer must be careful when signing long term contracts in order to obtain the best pricing for communication circuits. Providers may waive installation fees and provide discounted services for a long term contract. However, early termination penalties can include disconnect fees, paying the installation fee and paying the difference between the monthly discounted cost and the standard cost of the line.*

### III. Network Equipment

This section covers the network equipment needed and some of the basic configuration information required to get the network up and running.

The first item that needs to be discussed is the demarcation point (DEMARC). A DEMARC (Figure 2) is the location in the facility where the WAN network connection provided by the phone company terminates and the user's responsibility begins. The DEMARC may also be referred to as the "smart jack" provided by the telecommunications company. This jack is typically located in the telecommunications room in the facility. The user's LAN equipment, usually a channel service unit/data service unit (CSU/DSU), router or ISDN termination equipment connects to the smart jack which then connects the LAN to the WAN.

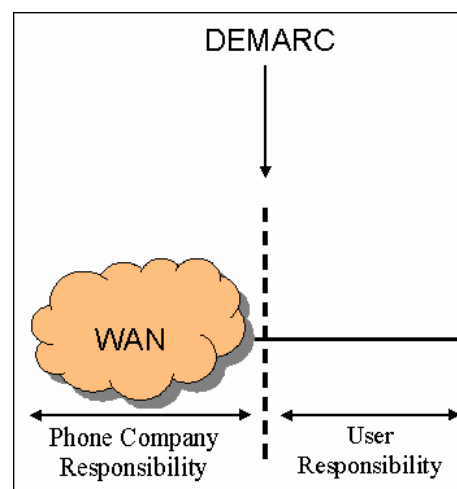

Figure 2

The CSU/DSU is a device that connects to the smart jack. The CSU/DSU conditions the network connection and allows the user to connect their network equipment to the WAN so that information can be processed properly. A CSU/DSU can be a stand-alone piece of equipment or it can be built into a router. For simplicity sake, this section assumes that the CSU/DSU is a part of the router. Thus, the illustrations will show the router actually connecting to the smart jack.

### **IP Network Equipment**

**Routers** pass information from point to point until it reaches its destination. For instance when equipment on the LAN sends information that is intended for someone not connected directly to the LAN, it is first sent to the local router. That router then passes it to another router and so on until it finally reaches its destination. Routers work together to find the best route to pass information. The best route may not always be the shortest route. If the longer route has a faster network connection or is less congested, the router may send the information in that direction.

It should be noted that most networks have some level of redundancy so that if one particular router in the path fails, the other routers will look for alternative paths (see Figure 3).

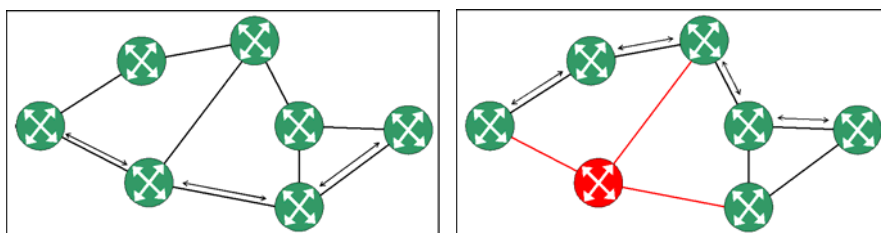

Figure 3

Once the router is connected (Figure 4) within the facility, multiple devices can be connected to the network (e.g., PCs, videoconferencing devices, printers, etc.). In order to make those connections a network switch or network hub is required.



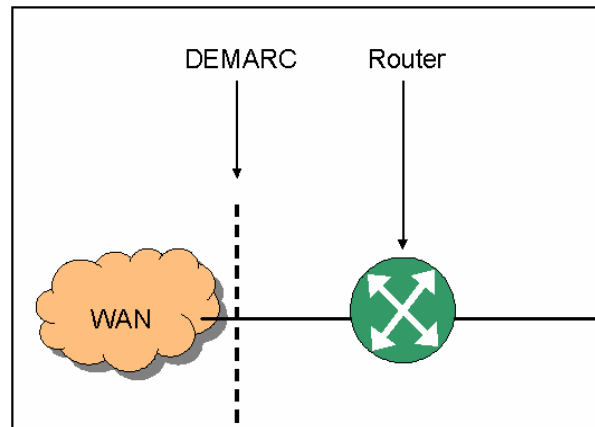

Figure 4

Switches and hubs are devices that allow the connection of multiple devices to a LAN. Although these two devices accomplish the same basic task by connecting multiple devices to the network, they do it in very different ways.

### Shared Network

A **Hub**, sometimes called a concentrator, is a device that allows for multiple network devices to use a single connection. A LAN using a hub is called a **shared network**. All devices connected to a hub share the bandwidth available to the network. Hubs do not distinguish between the types of equipment connected to it. If any piece of information comes its way, it sends it out to every piece of equipment on the network, even if the message is only meant for one particular device (Figure 5).

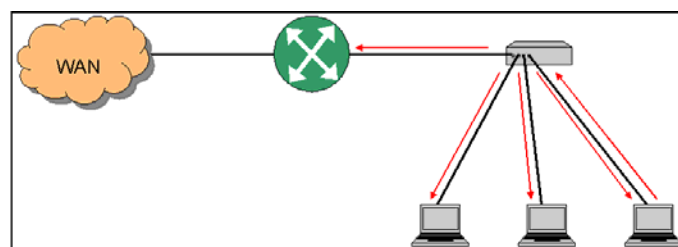

Figure 5

In this environment the more data that is being sent across the LAN the more congested the network becomes with information that not every device needs (Figure 6).

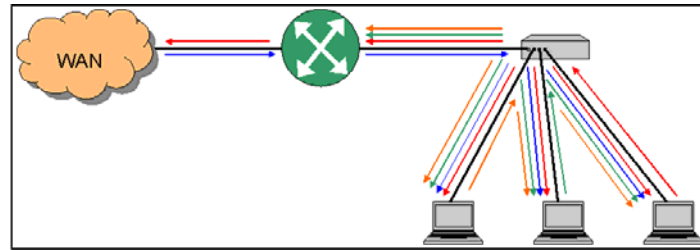

Figure 6

Another thing to consider on a shared network is that any one device connected to the hub can only send or receive information at any given time. This is referred to as **half duplex**. If two devices try to send data at the same time, a **collision** ensues. Collisions happen when two pieces of data traveling down the same network line “bump” into each other. When this occurs, both pieces of data are thrown away and the equipment must retransmit it. All this takes only a fraction of a second, but this does introduce latency. **Latency** is the time it takes a piece of data that is transmitted by a piece of network equipment to be received at its destination. According to some videoconferencing specifications<sup>1</sup>, video conferencing becomes unusable with latency greater than 300 milliseconds or 300 ms.

In videoconferencing, video and audio data are considered separate and they are sent across the network at different times. If there is too much latency between the video and the audio data, the lips of the person speaking and the sound coming out of their mouth will not match or will not be available at all. Audio data packets are much smaller (480 bytes or less) than video data packets (800 to 1500 bytes) and therefore audio will usually arrive at the destination first because it takes less time to route smaller packets. If the latency is too great, the data is dropped before it reaches its destination and the observer sees a break in the audio and/or video.

A shared network is never recommended for any type of video conferencing. The authors strongly recommended that a switched network be used for videoconferencing because a switched network is much more efficient in handling data traffic.

## Switched Network

A switched network uses a device known as a **switch**. When a device (e.g., PC, videoconferencing unit) is plugged into a network switch, that device tells the switch it's "name". Every network device has a serial number "burned" into it that is different from any other network device in the entire world. That serial number is known as a **MAC (Media Access Control) address**. Network devices communicate with each other on a LAN using the MAC address. The switch keeps track of what MAC address goes with each device that is connected to the LAN. As different devices are plugged into the switch, it keeps track of which MAC addresses are connected to which port on the switch. The switch then uses this information to make the decision on where it should send the data (Figure 7).

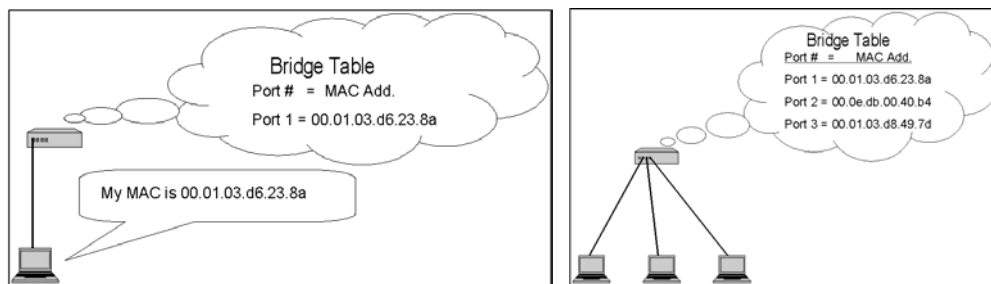

Figure 7

This process of storing MAC addresses allows the switch to send data only to the device that should receive it. This alleviates many of the problems associated with congestion on a shared network. The switched network is much more organized about how it sends and receives data. A switch also allows data to be sent in both directions at the same time. This is referred to as **Full Duplex**. Since a switch can send and receive data at the same time, no collisions occur and latency is reduced (Figure 8).

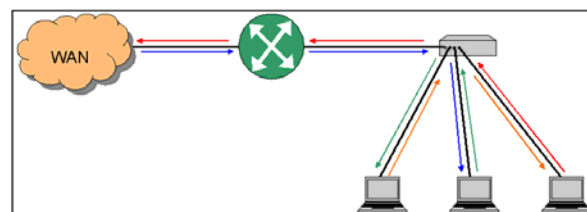

Figure 8

Figure 9 shows recommended network configuration that has been discussed so far.

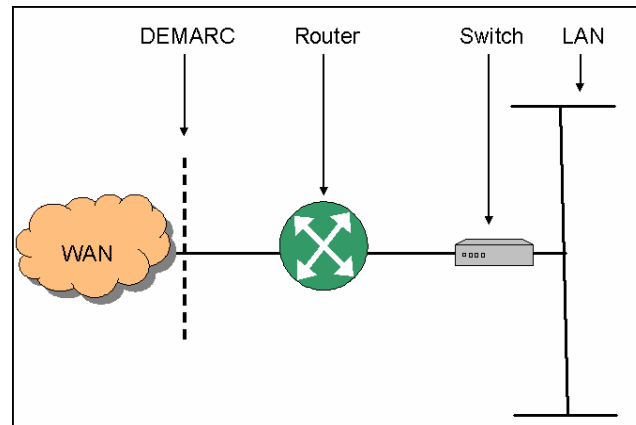

Figure 9

So now that the recommended configuration is in place its time to discuss adding nodes (devices) to the LAN. A **node** refers to any device connected to the LAN. This includes devices such as computers, printers, servers, and videoconferencing units (Figure 12). Each node connected to the LAN is given an address to distinguish it from other devices on the network. Thus, data intended to be sent to a specific address will arrive at that address in the same manner as a letter being sent from one organization to another.

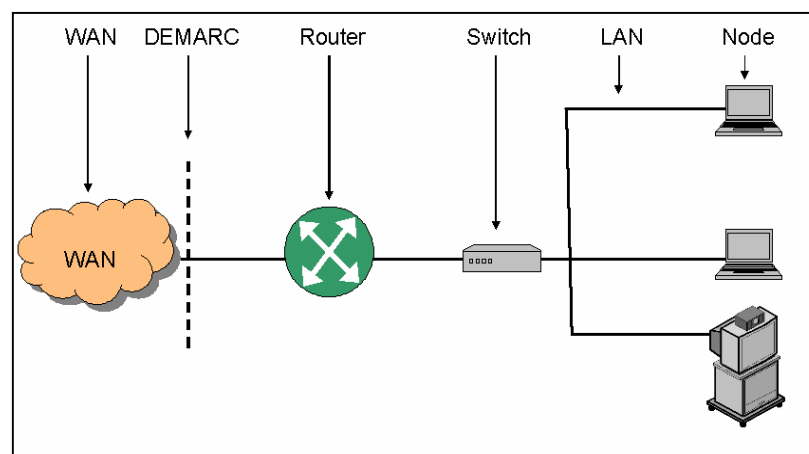

Figure 10

## **ISDN Network Equipment**

An ISDN connection is made up of 2 or more 64 Kbps or 56K connections or more appropriately, referred to as **channels**. For the purposes of this discussion 64 Kbps channels will be used. It should be noted however that if an ISDN line is ordered from a phone company, the person ordering the service should ask about the size of the channels that will be employed under the service.

There are two main types of ISDN – BRI and PRI. **BRI** means **Basic Rate Interface** while **PRI** means **Primary Rate Interface**. BRI connections consist of two 64 Kbps Bearer channels and one 16 Kbps Delta channel while a PRI connection has 23 Bearer channels (64 Kbps) and one 64 Kbps Delta channel.

**Bearer** channels are the ISDN channels that actually carry data such as audio and video. The **Delta** channel carries information such as who is being called, where the call is coming from, the speed of the call desired and other information pertaining to how the call should be setup, maintained and terminated when completed.

In order to make these individual channels of any use for video conferencing, they need to be able to carry large amounts of data. A 64 Kbps bearer channel is about the same amount of bandwidth as a standard telephone line. The way an ISDN PRI is configured, one could place 23 individual ISDN calls using 64 Kbps of bandwidth each. A 64 Kbps call would get decent audio, but only about 2 to 3 frames of video per second. This would be similar to using a POTS based videoconferencing device. A majority of videoconferencing calls for telehealth are made using 384 Kbps of bandwidth. To place an ISDN video call using 384 Kbps of bandwidth, an inverse multiplexer (IMUX) will need to be utilized. However, inverse multiplexers work a little differently depending on the type of ISDN service used (BRI vs. PRI) to place a 384 Kbps call. The differences are described below:

### ISDN BRI 384 Kbps Video Call:

In order to achieve a bandwidth of 384 Kbps using ISDN BRI services, inverse multiplexers must be used to combine (bond) 3 separate BRI lines together (128 Kbps x 3). Figure 13 below illustrates how this configuration is achieved.

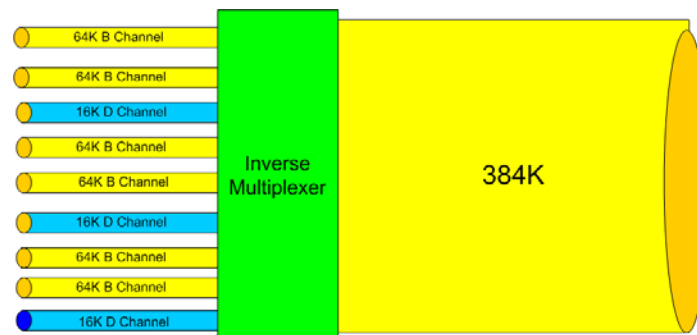

Figure 11

### ISDN PRI 384 Kbps Video Call:

As discussed above, an ISDN PRI line has 23 channels (64 Kbps each) available for a videoconference. In this case the IMUX is used to select the number of 64 Kbps channels needed to place a 384 Kbps call. Figure 14 below illustrates how this configuration works.

It should also be noted that depending on the capabilities of the IMUX, one ISDN PRI line could simultaneously support three 384 Kbps video calls.

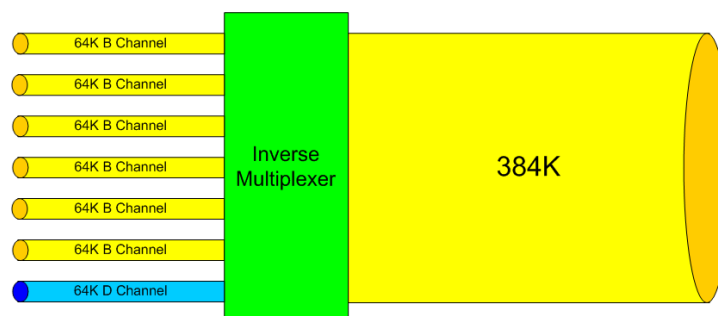

Figure 12

**ISDN Addressing**

In order to place a video conferencing call using ISDN one needs to tell the ISDN equipment the number that needs to be called. In most cases this is as easy as dialing a telephone. When ISDN line is ordered, the request will include a block of ISDN numbers that will be associated with the line. Those numbers can be used to dial out or accept incoming calls to the videoconferencing system.

**Other ISDN Considerations:**

The good thing about using ISDN for videoconferencing is that whatever bandwidth is used for the call, that bandwidth is guaranteed for the duration of the call. However, depending upon the ISDN calling plan purchased, ISDN can be more costly per month than a dedicated line. For example, many ISDN PRI plans have a per-minute charge associated with placing a long distance videoconferencing call. This per-minute charge is multiplied by each 64 Kbps channel used in a call. For example, a 384 Kbps ISDN PRI call uses six 64 Kbps channels, so the per-minute charge per channel is multiplied by six. Depending upon the per-minute rate for each 64 Kbps channel, ISDN can be rather expensive for long, high-bandwidth conferences that involve toll charges, but it can be cost effective for local calls. In short, when ordering this service review the calling plan options carefully and compare the estimated cost of ISDN service to the cost of a dedicated connection at a flat rate.

**POTS Network Equipment**

As stated before, POTS stands for Plain Old Telephone Service. A POTS connection is nothing more than a basic telephone connection. Though bandwidth is very limited on a POTS connection, it does work well for store and forward applications (e.g., monitoring devices, digital pictures). POTS can also be used for videoconferencing when broadband is not an option or is not economically feasible (e.g., homecare). POTS based connections can also be used to transmit heart sounds, using an electronic stethoscope, to a receiving station where they are heard by a cardiologist.

## IV. Telehealth Equipment

### Videoconferencing Equipment

This section will cover some basic concepts of videoconferencing equipment, the different components, and how they interact. To understand how the equipment is used, the basic principals of how the equipment operates is needed.

The two basic categories of videoconferencing equipment are **analog** and **digital**. Analog devices include devices such as microphones, speakers, video monitors, some cameras and telephones. Digital devices include CODECS, MCU's, and routers.

There are very important differences between analog and digital signals. An analog signal is a signal with infinite combinations of amplitude and frequency. Sound and light are two types of analog signals. Sound wave patterns go from subsonic to supersonic and all frequencies in between. Light signals go from infrared to ultraviolet and all frequencies in between.

A Digital signal, on the other hand, is made of electrical pulses with two possibilities, on or off.

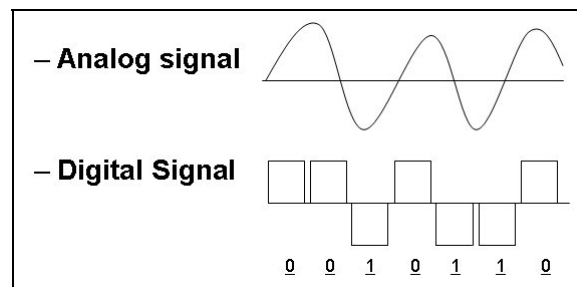

A person can only see and hear analog signals. Digital signals make no sense to the human brain but are needed in order to transport audio and video over a high speed, digital network connection.

In order to transport audio and video over a network, analog signals need to be converted to digital signals for transport and then converted back to analog after



transport. The device that does this converting is called a CODEC. **CODEC** stands for **Coder/Decoder**. Examples of CODECs are videoconferencing equipment that is used in telehealth facilities, meeting rooms and schools. Polycom, Tandberg, and Sony are some manufacturers of CODEC equipment.

To insure that CODEC equipment made by different manufactures can work together, there are a set of videoconferencing standards in place. The most common standards for videoconferencing are ITU-T (International Telecommunication Union Telecommunication Standardization Sector) H.323 and H.320. The H.323 standard is used for videoconferencing on IP networks and H.320 is the standard used for ISDN networks. These standards are further broken down into **protocol** standards for data transport over networks, video protocols, audio protocols, far end camera control, and file transfer. In order to communicate with people outside of the organization's network, it is important to know what standard protocols the videoconferencing equipment uses. Some examples of standard protocols that video conferencing equipment can use are:

- Video: H.261, H.263, H.264
- Audio: G.711, G.722
- Camera control: H.281
- Data transfer: T.120

For more information on these protocols and others please refer to one of the following:

- Federal Standard 1037C - Glossary of Telecommunication Terms
  - <http://glossary.its.bldrdoc.gov/fs-1037/> (accessed 6/8/04)
- Newton's Telecom Dictionary, CMP Books; 16<sup>th</sup> edition.
- WireOne Videoconferencing Glossary
  - [http://www.wireone.com/support\\_glossary.html](http://www.wireone.com/support_glossary.html) (accessed 6/8/04)
- Association of Telehealth Service Providers – Telemedicine Glossary
  - <http://www.atsp.org/telemedicine/glossary.asp> (accessed 6/8/04)

---

## **Camera Technology**

Most of today's videoconferencing systems come equipped with a **pan-tilt-zoom** (PTZ) camera. This refers to the camera's ability to pan (side to side movement); tilt (up and down movement); and zoom (the camera's ability to make objects look closer than they really are). Other camera functions such as auto white balance and auto focus will be discussed later in the *Room Selection* section.

## **Monitor Types**

Monitors are connected to the CODEC to display images of people and things on a screen. There are a few things to consider when choosing what type of monitor to use for videoconferencing. Some basic monitor types are Direct View or CRT, Plasma, and LCD monitors.

**CRT** or **Direct View** monitors are the most common monitors used for videoconferencing. CRT monitors are the same kind of monitors that have been used for televisions and computer monitors for years. They have some distinct advantages such as high picture quality, high color quality, and excellent contrast quality. As far as picture quality, a CRT monitor is good all around. The disadvantages of a CRT monitor are size and weight. Because of the large, thick, glass parts of the CRT or **Cathode Ray Tube**, a 27" monitor can weigh around 110lbs and be about 20" deep. This can take up a lot of room in a small area. If a CRT monitor is used in a small area, a 20" monitor or smaller is recommended.

Another type of monitor is a **Plasma** monitor. Plasma monitors are very thin and relatively light which makes them great to hang on walls in small areas. A 32" Plasma monitor can weigh approximately 25lbs and be as little as 5.5 inches thick. Although Plasma monitors are much higher in price than a CRT monitor, they are usually much less expensive than a LCD monitor. The main disadvantage of the Plasma monitor is a low life expectancy of only around three years. After this time it will probably need to be replaced.

**LCD** or **Liquid Crystal Display** monitors use microscopic crystals that allow light to pass through when a small amount of electricity is applied to them. They have a good picture quality although not as good as CRT or Plasma. LCD monitors are very thin and light which makes them great to hang on the wall for small rooms. They are however more expensive than CRT or Plasma monitors. As of this writing a 32" LCD monitor will cost about \$5000-\$6000 but has a life expectancy of about nine years and it will weigh about 50lbs.

### **Monitor Connection Types**

How well the video images are displayed on the monitors is dependent on the type of connection from the CODEC to the monitor. In this section three basic ways to accomplish this are discussed – composite, s-video, and component connections.

**Composite** video connections are common in consumer grade VCRs. A composite connection pushes all video information through one wire and has a low video resolution of 300 lines on the monitor screen. **S-video** connections provide a higher resolution than a composite connection at 500 lines. Most of the popular videoconferencing equipment today uses s-video connections and is recommended for higher quality images. **Component** connections offer an even higher video resolution at 2000 lines of resolution. This technology is mainly used for DVD players and HDTV.

It should be noted that the line resolution of the CODEC typically limits the resulting resolution. Thus, lower resolution video connections often provide the maximum resolution that can be transmitted.

### **Video Frame Rate**

Video frame rate is how many times per second that an image is redrawn on the monitor screen during a videoconference. The most common video frame rates are 15, 30, and 60 frames per second (fps). Usually a 15 fps videoconferencing call is one that uses less than 256 Kbps of bandwidth and produces video that tends to look a little jerky. Many computer desktop videoconferencing equipment use 15 fps.

Videoconferencing calls using 265 Kbps – 512 Kbps of bandwidth typically use a 30 fps frame rate. This is the most widely used frame rate in videoconferencing today as most videoconferencing takes place using 384 Kbps of bandwidth. The frame rate of 30 fps makes for a smooth picture in a videoconference as long as there is no broad, sudden, or exaggerated changes/movement taking place on the screen.

Some brands of videoconferencing equipment are capable of frame rates of 60 fps when calls take place above 512 Kbps. A frame rate of 60 fps makes for a near TV broadcast quality picture, but require more bandwidth to place to call. This frame rate is not used very often and may not be compatible with some videoconferencing equipment.

### **Audio Technologies**

Most videoconferencing equipment today includes **acoustic echo cancellation** or **AEC**. If it were not for AEC, when a person would speak, their voice would travel into the microphone to the remote site, be heard from the remote site speaker system, travel into the remote site microphone and be sent back to the sending site. This process may become an endless loop. AEC, however, looks for redundant sound patterns and eliminates the duplicate. While AEC works well, it is not foolproof; there are limits to what it can do but it can help reduce echo during a conference.

There is a learning time for AEC and the microphones to “listen” to the environment they are in and adjust themselves to the sound in that environment. If the sound properties change in a room, an echo may be heard for a moment. The microphone will have to readjust itself to the new sounds around it. When the microphone has learned its new sound surroundings, the echo should stop.

### **MCU Technologies**

A **Multipoint Control Unit (MCU)** allows multiple locations to be brought together in the same conference. It manages the audio, video and data streams from each participant to create a “virtual meeting room”. Participants can be displayed on the screen in several ways, depending on the set up of the MCU. The most common way is for each

site to see whoever is speaking at the time. When one person is finished speaking, the next person to speak would be displayed on the participants monitor.. This is known as **Voice Switching**. Another mode that is sometimes available is called **Continuous Presence** where the monitor shows a matrix of squares with each participant being seen in one square the entire time.

MCU's can be hardware or software based.

- Software based MCU's tend not to have the features and reliability of hardware MCU's, but are less expensive and run on a computer based server.
- Hardware MCU's are more reliable, offer more features and are more scalable than software based MCU's. Scalability allows multiple MCU's to be connected together to allow more sites to connect for a larger meeting.

Bandwidth can be a concern when using an MCU. For example, assume that a multipoint videoconference with 5 sites is desired and that each site will want to use 384 Kbps of bandwidth ( $5 \times 384 = 1.920$  Mbps). If the only available line to the MCU is a T1 (1.54 Mbps) line, the multipoint conference would not be possible because the available bandwidth is less than the required bandwidth. In other words this five site videoconference would require each site to use bandwidth that would total more than the MCU's available network connection.

There are several variations for multipoint videoconferencing that one should consider when purchasing an MCU:

1. The budget – hardware MCU's can be quite expensive (\$20k-200k range).
2. The types of connections that will be needed – IP, ISDN or both.
3. Estimated MCU utilization - If the MCU is not going to be used very often it may be more economical to use the services of a commercial videoconferencing facility where all sites dial into the commercial MCU at some predetermined hourly charge.

4. Some videoconferencing units come with built-in MCU's that allow for a limited number of multipoint connections (e.g., up-to three). Thus, the end-user needs to determine if a need exists for larger multipoint conferences before purchasing an MCU.
5. Vendor support and any periodic costs such as software upgrades also need to be considered before purchasing an MCU.
6. The need to integrate endpoints of at different network speeds.
7. The need to integrate audio calls.

### **Auxiliary Telehealth Equipment**

There are many different pieces of equipment today that may be added to basic videoconferencing and network equipment that can be used for telehealth.

Most videoconferencing systems come equipped with one or more auxiliary camera ports to attach additional cameras. In some cases, high resolution cameras can be used for dermatology or connected to a microscope and used for classroom instruction in microbiology and pathology. Other more specialized cameras exist, such as fiber optic videoscope systems used for examining the ears, nose and throat.

Some manufacturers have electronic analog and digital stethoscope equipment that will transmit heart and lung sounds to a remote location. Because these heart and lung sounds can be digitized, this allows for flexibility to amplify, and equalize the sound to pick up more specific sounds and make them much easier to hear than with a conventional stethoscope. As always, the provider must decide if the equipment is suitable for clinical care.

### **Store and Forward**

Store and forward applications are images, sound, or data that are stored on a piece of equipment and transferred at a later time when it will be reviewed by a provider. Some

examples of Store and Forward technologies would be digital cameras used for taking and sending images of dermatology or wound problems, electronic scales that capture and directly send a patient's weight to a receiving station, echocardiograms that are digitally captured and sent to a cardiologist, etc. Other forms of store and forward that have been in place for years include teleradiology systems, telepathology systems, and EKG systems. One advantage of store and forward technologies is that the patient and the doctor do not need to be at certain locations at the same time.

## V. Room Evaluation

This section will discuss what characteristics to look for when choosing or refurbishing a room for videoconferencing. The subjects covered pertain to what video and audio properties to look for when choosing a room.

Before installing Telehealth equipment in the designated room it pays to spend a few moments evaluating the area. The ideal telehealth room will be a quiet room. The walls will be solid blue or gray in color and have some sort of cloth, padding or sound panels on them to absorb some sound. Fluorescent lighting will be in the room with the bulbs being 3200 to 4700 Kelvin degrees in temperature. Lighting will cover the top and front of conference participants and will be adequate for the room's size. Windows, if any, will be covered with room darkening cloth curtains. Any tables in the room would be dark in color, non-glass top, and cloth covered if possible.

Each of the items in the previous paragraph has a valid reason for being mentioned. When selecting or building a room to be used for telehealth, the goal is to make the telehealth experience a comfortable one for all involved. If the participants are well seen and well heard, they will be more relaxed. The idea is to make the technology completely transparent to the users. The following paragraphs will explain why the issues mentioned above should be taken into consideration when selecting or creating a telehealth room.

---

Color is a very important element in a good videoconferencing room. Background colors, foreground colors, clothing colors, all effect how things are viewed on the screen. White and red clothing is not good since these colors tend to “bleed” into surrounding colors on video. Cameras work best when a blue or gray background is used. Most videoconferencing cameras automatically adjust how much light reaches the camera lens according to the brightest object in view. This is known as **automatic white balance**. If the walls are white, then the camera will adjust to the wall color by closing the iris located behind the lens. This will cause the participants in the videoconference to appear too dark. The opposite would be true of a wall that is black. A wall that is blue or grey will allow the iris to open more and the videoconferencing subjects will appear bright and clear.

Patterns on walls located behind the conference participants can cause blurring of the subjects because the camera will try to focus on the background pattern instead of the videoconferencing subjects. This is especially true if the background pattern on the walls contain vertical lines. **Auto focus** cameras look for vertical edges and attempt to bring them into focus as much as possible. If a wall behind the conference participants contains vertical lines, the camera could be focusing on the wall causing the subjects to appear blurry. In short, room designers should avoid patterned wall coverings.

One also needs to consider background and foreground objects such as light switches, coat racks, chairs, other cameras, etc. Not only can they be distracting to the cameras, they can be distracting to people participating in the conference. People may be looking around focusing their attention on the objects in the room instead of the intended subject. If possible, remove or relocate objects that may be distracting so only the principal subjects are seen during a video conference.

A camera perceives light in a different way than human eyes do. What is seen with the eye may not appear so on the screen. Different types of light add different color to the camera lens. For instance, sunlight adds blue light. This will cause the subjects to appear to have a blue tint. Incandescent light, light bulbs used in lamps found in most



homes, add red and will cause the subjects to have a red tint. Fluorescent lights add different color depending on the temperature of the light.

The temperature of fluorescent light is measured in Kelvin degrees. The lower the temperature of fluorescent lights the more red the light will appear on the subjects while higher temperature lights will add more blue. The degree of a light is usually printed on the fluorescent bulb itself. A fluorescent bulb with 3200 to 4700 degree Kelvin is generally acceptable for videoconferencing. Fluorescent lights are always recommended for any type of video conferencing.

Up-lighting installed in a room is the best kind of lighting for video conferencing. **Up-lighting** refers to the type of light fixture mounted from the ceiling and directs the light upward to reflect it off the ceiling and walls to provide indirect lighting on the participants. Most florescent light fixtures shine directly down in a room and this is known as **down-lighting**. Down-lighting from ceiling lights cause what is referred to as “raccoon eyes” – where the eyes appear shadowed out. One of the goals in videoconferencing is to create the illusion of eye-to-eye contact and this will be difficult to create if the participants at the remote site cannot see your subject’s eyes. If up-lighting in a room is not possible, front lighting or lights mounted on the wall that direct light on the front of participants can solve the problem associated with down-lighting.

**Backlighting** is caused by windows located behind the videoconferencing subjects and will cause the entire subject to be shadowed out so that only a silhouette of the subject can be seen. Backlighting can be solved in a number of ways: (1) relocate the subjects in the room so the window is not behind them; (2) install shades or curtains over the window; or (3) use the backlight compensation setting on the videoconferencing equipment if 1 and 2 are not possible.

It is also important to know the audio properties of the room where videoconferencing activities will take place. In the process of evaluating a room for its sound properties, take a look at the walls, floors, and furniture in the room. Cloth covered walls, carpeted

floors, wood tables, and cloth curtains over the windows will help reduce sound reflection in a room.

Sound **reflection** happens when sound bounces off of objects in a room. These objects include people, walls, floors, tables, etc. Reflection is an effect that may cause sound from a speaker to be entered into a microphone more than once. Sound reflection is often confused with an echo.

In videoconferencing an **echo** is when one's voice travels to the remote site then travels back via the video conferencing equipment. In most cases this is caused by the microphone being placed too close to the monitor speakers at the other site. This causes the sound to travel to the remote site, into their microphone, and back to the person speaking. The solution to this problem is to move the microphone away from the monitor speaker at the remote side and/or turn down the volume at the remote side. The important thing to remember is that if one's own voice is heard during a videoconference, the problem is always on the other side.

**Ambient sound** is all sound in a room that one has no interest in hearing. These sounds include fan noise, furnace noise, talking from other rooms, noise from outside through windows, etc. In other words, background noise. The louder the ambient sound in a room the louder the videoconferencing subjects will have to speak to be heard. Ambient sound can also be distracting to participants at the originating site.

Also be aware of potential hidden noise. **Hidden noise** is sound that is not always present but could possibly have an influence on a videoconference. Examples of hidden noise are using the conferencing room during winter months when the air conditioning is not running to find out if during the summer ambient noise is a problem. The same would go for checking a room in the summer when the heater is not running. Other examples of hidden noise could be nearby bathrooms, appliances, overhead paging systems, etc.

When choosing or designing a telehealth room, use an approach like designing any other medical exam room. Keep in mind the intended purpose of the room and the goal

of making this room comfortable for everyone using it. A little planning before implementation will help avoid problems later.

References:

1. [http://eknowledge.polycom.com/SRVS/CGI-BIN/WEBCGI.EXE/,/?St=49,E=0000000000000072030,K=425,Sxi=13,Case=obj\(2989\)](http://eknowledge.polycom.com/SRVS/CGI-BIN/WEBCGI.EXE/,/?St=49,E=0000000000000072030,K=425,Sxi=13,Case=obj(2989))

## Chapter Fourteen

---

### Trauma and Emergency Care

**Authors:** Michael A. Ricci, MD, Fletcher Allen Health Care & University of Vermont  
Michael P. Caputo, MS, University of Vermont

#### **Contributing Editors:**

Samuel Burgiss, PhD, University of Tennessee  
Joseph Tracy, University of Missouri  
David Ellis, MD, Erie County Medical Center  
Joseph Dutkowsky, MD, Bassett Health Care

#### **I. Introduction**

The purpose of this document is to provide an overview of the problems associated with rural emergency and trauma care and the potential support provided through the use of telemedicine. This work was funded by the Office for the Advancement of Telehealth (OAT/HRSA/PHS 6 D1B TM00081-01-01 Supplement)

#### **II. Background**

In 1966, the National Academy of Sciences published a document <sup>1</sup> which highlighted trauma as a major national health problem, leading to a revolution in trauma care for the next 30 years.<sup>2</sup> Yet, the conclusions in that report were based upon data gathered from urban trauma centers, which may not be applicable to rural trauma and emergency care.<sup>2</sup> Though one-third of the nation's population lives in "rural" America, a disproportionate number of deaths due to motor vehicle crashes (56.9%) occur in rural areas.<sup>3</sup> Rogers and colleagues outlined the numerous problems and significant discrepancies in rural trauma care in a comprehensive review article published in 1999.<sup>2</sup> This work outlined a number of solutions, including improved training for rural hospital surgeons and emergency medical services (EMS) personnel, a better match-up of resources and injuries when determining transport to trauma centers, and use of telemedicine for support of rural hospitals.

Rogers and colleagues noted the paucity of studies with objective evidence of the value of telemedicine technologies, particularly in trauma and emergency care.<sup>2</sup> They concluded:

1. *The Committee on Trauma of the American College of Surgeons must take the lead and address issues of credentialing, liability and privacy with regard to the use of telemedicine in trauma. Specific regulations must address teleconsults that cross state lines.*
2. *Sustainable sources of funding must be found to allow telemedicine programs to be continued in perpetuity. Remuneration to physicians for teleconsults may provide a more tenable long term solution.*
3. *The impact of telemedicine on outcome and its efficacy in improving education and competency of rural providers must be evaluated.”*

This chapter will address some of the progress that has been made since that report, discuss potential technology solutions to address discrepancies in the delivery of trauma and emergency care as well as potential barriers to implementation, and suggest approaches to development and implementation of telemedicine trauma and emergency programs.

### **III. Step-By-Step Guide To Creating A Successful Program**

#### **A. Define the Need**

There are several important factors to consider when defining the needs to be addressed by a telemedicine support program for trauma or emergency services. These factors can be simplified by considering who, what, where, when, and how.

- *Who* are the key people that need to participate in defining and supporting the project?
- *What* services are necessary?
- *Where* are the most logical sites that should participate (rural and consulting)?

- *When* are the services needed (7X24, night time, weekends, etc.)?
- *How* are these services best supported (i.e., is *telemedicine* really the best solution)?

First, the key stakeholders must be identified. Those will include the rural emergency department providers, the rural administrators, the rural technical and EMS staff, the consulting center physicians, administrators, and the consulting center technical staff. A core team will be needed to ensure the success of the project. The members of this team should include clinical and technical staff at the tertiary site and clinical champions from the remote sites. Once these people have been identified, they must participate in defining the scope of the project. Specifically they must agree on the services that are necessary and what protocols will be followed. This is best accomplished by looking at existing data rather than by unfounded speculation. Remember, the purpose of defining the need is to identify existing needs, not things that would simply be “nice to have”. One set of data that can assist in this process is existing information regarding the types of cases admitted to the remote emergency departments (EDs) and the cases transferred to the tertiary center. Other helpful information includes the types of specialty services that are requested from outside locations. These factors will help to determine the services most likely to be needed at the remote hospitals. Furthermore, it is important to determine which sites should participate. This determination can be influenced by factors such as: physician buy-in, management support, the ability to support the technical infrastructure (both from a personnel and budgetary standpoint), and matching the services needed to those that can be provided by the consulting center. Finally, and perhaps most importantly, there is always more than one way to solve a problem. Many telemedicine projects fail because the use of telemedicine technology was not the best solution for the given set of circumstances.

## **B. Assess Equipment Options**

There are generally two categories of telemedicine workstation equipment: store-and-forward videoconferencing, or interactive videoconferencing. Interactive videoconferencing is the option most often selected for emergency or trauma situations.

The ability to receive motion video and audio is more desirable for emergent situations when timely access to more information is of critical importance. However, the store-and-forward solution is most often selected when access to high bandwidth communication is not available, or when very limited funds are provided for the project.

In addition to telemedicine workstations, peripheral devices are necessary for supporting trauma or emergency telemedicine sites. Medical devices such as ultrasound, close-up examination cameras, electronic stethoscopes, video otoscopes, and video ophthalmoscopes can be useful in transmitting images of the patient to the remote consultant. Access to ECG, MRI, or CT scans is also important. Many of these devices can be connected through the telemedicine workstation. If not, it may be possible to access these images through other means, such as a secure webserver, a document camera, or aiming the telemedicine workstation camera at the viewbox in the ED. For supporting trauma cases, the location of the video camera for the interactive video system is critical. This camera must be placed in a location that allows easy viewing of the trauma bed(s) and should provide the consulting trauma surgeon with control of pan, zoom, and tilt. The camera is often secured to the ceiling so that the remote surgeon receives a birds-eye view of the situation with the ability to zoom in or out.

The microphone that is used in the rural site should be placed over the trauma bed or between the trauma beds if a single microphone is used. One potential problem with a single microphone solution is that emergency departments can become very noisy during a trauma case. An alternate solution is to use a wireless headset with a self-contained microphone and speaker so that the emergency room provider can have uninterrupted communication with the trauma surgeon regardless of noise conditions or the presence of the patient's family. The military is testing other microphones in conjunction with Personal Digital Assistants (PDAs) and speech recognition systems that eliminate the loud background noises found in these environments.<sup>4</sup>

In the experiences gained in Vermont and New York, it has been determined that dedicated telemedicine systems are the best way to support tele-trauma care. This

means systems dedicated in the rural emergency departments, multiple units in the Level I trauma hospital, and dedicated units in the home of each surgeon who participates in the tele-trauma call schedule. Alternatives might include a central “receiving” station, such as the emergency room or communications center at the trauma or medical center.

### **C. Assess Transmission Options**

While there are many options available in selecting a transmission solution, it is important to determine what is available and affordable for the project. Geographic remoteness often reduces the number of options available for connecting telemedicine sites. Plain Old Telephone Service (POTS) can support still image transmission (store-and-forward) or low speed (low quality) video. This may have limited applicability for many emergency situations, however. Digital phone lines, Switched-56 or ISDN, can be used to support interactive video. The tele-trauma program at Fletcher Allen Health Care (FAHC), the major 500-bed teaching hospital of the University of Vermont College of Medicine in Burlington, Vermont, uses three ISDN lines for a total transmission rate of 384 Kbps. Telemedicine workstations that can operate using Internet Protocol (IP) video can utilize existing networks to connect between facilities. IP video can be transmitted over campus networks, through cable modems or Digital Subscriber Lines (DSL), which channel the signal through the Internet, though great variations in uplink and downlink transmission speeds exist within these services. This has the potential to improve the ability to connect anytime and anywhere; however, anyone using IP video over the public Internet needs to consider security and compliance with federal and state medical privacy laws.

### **D. Estimate Costs**

The costs of supporting a telemedicine network for trauma or emergency medicine has three elements: people, telecommunications, and equipment. The costs of the people will not be addressed here as these costs vary widely from institution to institution and can be calculated easily by anyone who is contemplating a telemedicine project. The



amount of technical staff needed to support such a project, based on the Vermont Tele-trauma model, is 0.4 FTE at the trauma center and <0.1 FTE at each remote site. The transmission costs will vary depending on the solution selected. Some transmission lines, such as T-1, Cable, or DSL, charge a fixed monthly rate, but may require additional networking equipment to support this type of activity. However, other lines, such as Switched-56 or ISDN, carry monthly service costs plus charges for usage. The telemedicine workstation equipment should cost between \$5,000 and \$7,000 per site. This does not include additional peripheral devices beyond the video cameras used in conjunction with the video conferencing system (which could add between \$5,000 - \$20,000 per site depending on the peripheral devices selected). To calculate the annual support costs for this type of telemedicine program, determine the following:

- Number of sites = # of remote ED sites + # of trauma center units + # of surgeons' homes
- Equipment costs = ~\$6000 X # of sites
- Transmission costs = # of sites X (monthly telecomm fees + usage (if applicable))
- First Year Costs = Equipment + Transmission
- Future Annual Costs = Transmission

### **E. Address Policy Issues**

*Health Insurance Portability and Accountability Act (HIPAA)* – Provider-to-provider consultation for the purposes of medical treatment of emergency or trauma cases is not hampered by the HIPAA rules. Review your policies and protocols with Risk Management. If the information exchanged during the consultation is to be used for research purposes, the protocol would need the approval of the Institutional Review Board (IRB) prior to implementation. During the approval process for the research protocol, the need for informed consent, HIPAA authorization, and the potential for waivers would need to be addressed.

Joint Commission on Accreditation of Healthcare Organizations (JCAHO) – In 2000, JCAHO published medical staff telemedicine standards that required all hospitals to

credential physicians providing diagnosis and treatment using electronic communications. These guidelines required rural sites to credential all physicians providing telemedicine services to their institutions. Rural sites had the burden of creating credentialing procedures for specialists that did not even practice in their facility, while telemedicine providers were suddenly faced with the need to be credentialed by multiple hospitals. Much confusion regarding the JCAHO standard ensued but, fortunately, a revision to the standards went into effect in January 1, 2004.

The major change, designed to reduce the burden on the rural (originating) site, is “credentialing and privileging by proxy”. The new guidelines state, “Under special circumstances, the Originating Site (the site where the patient is located at the time the service is provided), is allowed to accept the credentialing and privileging decision of the Distant Site, (the site where the practitioner providing the professional service is located).”<sup>5</sup> This policy acknowledges that the distant site has more relevant information and expertise to credential specialty physicians than the rural (originating) site.

*Licensure* – Practice across state lines remains a potential problem that has not been addressed on a national level. Thus, the administrators of telemedicine programs must understand the licensure laws and appropriate state statutes within their respective service areas. Many states provide exceptions for emergency care.

*Liability* – To date, there has not been a successful telemedicine-based lawsuit. Before embarking upon a telemedicine program, the individual or institution’s medical malpractice carrier should be informed. In most cases, this will not be problematic. Ultimately, though, when it comes to liability in telemedicine cases, there are more questions than facts. For instance, if a telemedicine link is established between a trauma center and a rural hospital, and that rural site chooses not to use the link during a trauma that results in an unfavorable outcome, could that rural site and its physicians be held liable? If a recommendation is carried out in an emergency while using a telemedicine link, could an unfavorable outcome be blamed on the consulting trauma doctor asking for care that is beyond the scope of the rural hospital provider, on a rural doctor who fails to carry out the recommendation from the consultant, or simply on everyone involved,

blaming the telemedicine link as a distraction to care? Of course, no one knows the answers to these questions, but in medicine more information is generally a good thing and successful collaboration of physicians will improve outcomes.

## F. Operational Organization

The first key component for any telemedicine program is a commitment from the institution to telemedicine in general, and to trauma and emergency telemedicine in particular. Though a successful business plan and cost savings are the gold standard for any telemedicine application,<sup>6,7</sup> it is likely that some institutional support for trauma telemedicine will be needed, since the low volume and poor payor mix in rural areas makes it difficult to build a sustainable telemedicine program dedicated to trauma alone. This emphasizes the need for tele-trauma to be part of a larger telemedicine program that offers other services such as scheduled consultations and CME. Besides resources, commitment of upper level management, deans, and department chairs is a likely prerequisite for success.

The next key component for successful operations, more evident in emergency and trauma telemedicine than in any other field, is that there is someone to “answer the phone”.<sup>8</sup> Emergencies will not tolerate delays while someone tries to find consultants, nor will technical problems be tolerated – at least not more than once! Thus, there is precious little room for error. The Vermont telemedicine program leveraged an existing service within the medical center. The Provider Access Service (PAS) was established in 1994 to provide health care personnel with a single 800-number which will connect them with other providers, both inside and outside of the medical center. PAS has dedicated operators that handle more than 20,000 calls per month (24 hours per day, 7 days per week) with a 10-minute response time. Protocols are in place for handling routine and emergency telemedicine requests. The remote site that calls in about a tele-trauma indicates the name of the hospital and the need for a tele-trauma consult. The PAS operator notifies the surgeon on call, who then makes a video call-back to the rural emergency department. In addition, PAS can route a caller to telemedicine technicians if they are calling to report a technical problem with their system.

As noted above, once the technical solutions are in place, tested, and dependably functional, the human factors come into play. It is safest that an individualized, well-thought-out coverage plan is in place well before implementation. There is no one plan that will fit all institutions. Typically, once the institutional and departmental commitment is made, solutions for coverage fall into place more easily. In some cases, a call schedule may be implemented, while in others the emergency room physicians on duty at the medical center will be responsible to respond to the rural site.

It would be simple if the operation of a successful trauma and emergency telemedicine program was merely a result of institutional support and a call schedule. In reality, with this still burgeoning field, physician leadership is the third major requirement. It is best if the physicians are clinically active and respected, so that they may “lead from the front” by incorporating the telemedicine solution into their own practices. It helps if they are technically savvy, can carve out time, and display a passion for the technology. It is better if there is more than a single leader, regardless of institutional titles or official roles.

Day-to-day operations of a tele-trauma program typically require the use of administrative, clinical, and technical functions. Depending on the institution, administrative components usually require some links to the Information Technology Department, Public Relations or External Affairs, and, in the case of emergency and trauma telemedicine, trauma surgery and emergency medicine departments. An organizational plan may place resources in any one of these components. The resources include the clinical and technical aspects of the organization. While the program may have a dedicated physician leader as described above, operations of a tele-trauma program likely will require physician leadership from the emergency room or trauma surgery division as well. In addition, a number of clinicians may be providing care, so protocols, schedules, and general organization will be necessary. With a diverse group, it can be expected that various levels of technical expertise will be found, so that technical support, readily available in the event of emergencies, is required. In general, testing on a regular basis avoids “emergencies”, but some problems are

inevitable. It is best if the technical staff communicates often with originating- and distant-site physicians and technical staff.

### **G. Implementation Timelines**

The timeline outlined below is intended to start *after* the project support has been gained and formal agreements have been signed between the participating institutions. This is also based on the assumption that technical staff already exist at the tertiary site; otherwise, they must be hired before this process is started.

#### *3-4 Months Before Start Date*

- Create protocols (clinical, privacy, credentialing, consent)
- File Universal Service Forms (if appropriate)
- Review HIPAA requirements with Risk Management or Legal Counsel

#### *2-3 Months Before Start Date*

- Technical site survey of each clinical site (remote & consulting)
- Technical site survey of each surgeon's home (if appropriate)
- Solicit bids on equipment and installation

#### *1-2 Months Before Start Date*

- Order equipment
- Order telecommunications lines
- Develop evaluation metrics for project

#### *2-4 Weeks Before Start Date*

- Install equipment
- Install telecommunications lines
- Preliminary testing

#### *1-2 Weeks Before Start Date*

- Complete testing
- Train site coordinators & ED staff

- Train new consulting physicians

#### *Start Date*

- Videoconference with each site to “meet & greet” the physicians and ED staff
- Implement twice-daily test calls to ensure system readiness

### **H. Outcome Measures**

Outcomes analysis of trauma and emergency programs should ideally include the following three domains: (1) clinical outcomes, (2) participant acceptability, and (3) costs. *Clinical outcomes* may be assessed by evaluating the usefulness of immediate connection to the trauma surgeons or emergency physicians with transmission of video images of the patient’s care, injuries, and test results during treatment of trauma victims by: 1) correlating the Injury Severity Score (ISS)<sup>21</sup> and outcomes (survival, complications, length of stay) in trauma patients managed with telemedicine to those patients transferred to the hospital but managed without telemedicine (by using data from the local Trauma Registry), and 2) by assessing both referring and consulting physicians’ perceptions of the usefulness of telemedicine management through survey questionnaires and in-person observations and interviews. The time of day of the consult, length of time in the rural ED, transport time, and total time to definitive care should be recorded and analyzed. *Participant Acceptability* may be assessed by recording participants’ perceptions of the usability of the technology, confidence in the diagnosis and value of telemedicine assistance, and efficiency of telemedicine. Finally, an estimate of costs should be obtained by looking at actual charges (correlated with injury severity), length of stay, etc., as well as “cost-avoidance (savings in transport, return visits, etc.).

### **I. Next Steps**

“Filmless” radiology departments are already making inroads in rural hospitals, allowing advance transmission of high-quality digital radiographs and computed tomography scans. Wireless applications will be the next specific major improvement in telemedicine

trauma and emergency programs. Wireless headset microphones will improve communication between consulting physicians and providers who care for patients in noisy emergency rooms or ambulances. Wireless data transmission to allow video from cameras in multiple locations, in the event of mass casualty situations, will be an advantage. Ultimately, wireless telemedicine systems from the scene to both the rural hospital and the trauma center will allow for better triage and faster transportation, as well as the potential for advanced interventions in the field or en route.<sup>22</sup>

Further in the future is the use of remote “virtual reality” systems that will allow tactile sensations to be transmitted to the distant physician who to help inform judgments regarding fractures or abdominal examinations.<sup>7</sup> Paralleling those advances will be the ability to perform surgery at a distance so that lacerations or even deep vascular injuries can be controlled or repaired by the remote trauma surgeon “virtually” operating in the rural hospital.

#### **IV. Case Studies of Trauma and Emergency Telemedicine**

##### **A. Fletcher Allen Health Care “Tele-Trauma” Program**

The current telemedicine program at FAHC began as part of a planned regional information system. Connecting a number of hospitals in Vermont and northeastern New York State, the program initially consisted of interactive real-time videoconferencing via ISDN (384 Kbs) that was used for the clinic a little more than half the time.<sup>9</sup> A variety of clinical disciplines used the telemedicine system at that time, including pathology,<sup>10,11</sup> gastroenterology,<sup>12</sup> vascular surgery,<sup>13</sup> and orthopedics.<sup>14</sup> As it became clear that there were discrepancies in the care of rural trauma patients as well as in the experience and training of rural providers,<sup>2</sup> it was apparent that the telemedicine system might provide a mechanism to begin to address these problems.<sup>15, 16</sup>

The need was apparent, based upon the knowledge of the region’s demographics and previous work. Vermont is 49<sup>th</sup> in population and has the largest percentage of its population (68%) living in rural areas, while the adjacent regions in New York, St.

Lawrence County, and Franklin County are the most rural counties in New York. Hospitals in this area are one to four hours away from the Level 1 Trauma Center at FAHC. In Vermont, local ambulance services are “unavailable” approximately 15% of the time,<sup>17</sup> helicopters are grounded by weather 30% of the time, and 90% of first responders staffing these vehicles are volunteers.<sup>2</sup> Half of these ambulance services respond to less than 100 calls per year, which can amount to as little as one trauma call for any individual provider per year.<sup>2,15</sup> Forty percent of pre-hospital personnel were trained at the basic Emergency Care Technician level and only 2% as Paramedics.<sup>2</sup>

The initial project at FAHC was funded by a grant from the Department of Commerce, Technology Opportunity Program (USDOC 50-60-99024), with subsequent grants for expansion of the network provided by the Office for the Advancement of Telehealth (VT Teletrauma Project: Advanced Interventions and Outcome Assessment (OAT/HRSA/PHS 1 D1B TM00081-01) and Pediatric Teletrauma: Advanced Interventions and Outcome Assessment (OAT/HRSA 2D1BTH00081-02-00)). The Department of Surgery funded travel to an instructional session in Chicago that led to the successful grant application. The funding required matching funds from the institution, which were provided by FAHC and the Department of Surgery.

The Vermont telemedicine program implemented a pilot study for assisting rural hospitals with trauma patients in April 2000. The project used ISDN lines and video conferencing workstations at 4 rural hospitals. Each hospital had the ISDN lines extended to the Emergency Department's trauma room.<sup>15,16</sup> To allow rapid response times when trauma patients arrived in the rural emergency rooms, a single 800-number was utilized to activate the system. An on-call tele-trauma surgeon was contacted, who then used one of multiple sites (including his or her home) to call into the rural emergency room using the telemedicine system. Because technical support could not be provided 24 hours per day, the system on both ends had to be simple and reliable so physicians could connect without technical support. This included remote camera control by the consulting trauma surgeon who could zoom



in on items of interest or move to look at a radiograph on a wall-mounted light box. Finally, equipment had to be small so that it did not impose upon the already cramped space in the rural emergency rooms.

At least one and often two visits to each rural hospital occurred before implementation. The Director of Trauma, the Clinical Director of Telemedicine, and the Telemedicine Operations Director all visited and met in person with rural emergency room doctors and local general surgeons, administrators, nurses, and EMS personnel. This was followed by technical support personnel visiting and working with local technicians to custom design each room setup at the rural sites. Tele-trauma protocols were put in place and posters with key information were made for each site. Operators at the trauma center also had protocols, call schedules, and special training. Twice-daily testing of all sites was initiated after a few early technical failures.

The tele-trauma protocol was developed by Dr. Frederick Rogers, Director of Trauma, at Fletcher Allen Health Care (see Section VI).<sup>16</sup> This protocol is posted in each participating rural hospital site.

The initial clinical experience has been previously reported.<sup>15,16</sup> In brief, over about 18 months, 41 tele-trauma consultations were performed at 3 sites. Most (66%) of the injuries were due to automobile, motorcycle, or motorized vehicle accidents. Blunt trauma was the predominant mechanism of injury (95%). Thirty-one of 41 cases were transferred. The most frequent reason for transfer was that a specialist was unavailable (neurosurgery, 58%; orthopedist, 32%; vascular surgeon, otolaryngology, or cardiac surgery, 3% each). The mean length of a tele-trauma consult call was 34.1 minutes ( $\pm$  23.5 minutes), with a range of 4.5 to 101.5 minutes. In three cases, the tele-trauma consultation was judged to be potentially life-saving though, most frequently, surgeons at the trauma center cited better continuity of care as the greatest impact of the program.

Evaluations indicated that the surgeons at FAHC as well as physicians at the rural hospitals rated the system as effective.<sup>18</sup> Both groups felt that the consults improved the quality of care: 63% of FAHC specialists and 83% of rural physicians “agreed” or “strongly agreed”. Both groups also felt the consults could not have been performed as effectively over the telephone. The overall conclusion that telemedicine is an adequate positive addition to trauma care was complemented by the results of on-site interviews and observations.<sup>18</sup>

The FAHC tele-trauma appears to be a successful model for telemedicine use that can be exported outside of Vermont. Key elements of the success include: (1) determining the need and knowing the population and region to be served; (2) departmental and institutional support; (3) physician leadership; (4) simple design and operations; (5) reliable equipment (and daily testing!); and (5) measurement of objective and subjective outcomes.

## **B. Bassett Health Care - Specialty Care in Orthopedics**

In 1995, Dr. Joseph Dutkowsky, a pediatric orthopaedic surgeon, started using still image transmission telephones to link the tertiary care facility to rural emergency departments to support orthopaedic emergencies and traumas. Bassett Health Care is located in Cooperstown, NY and provides services to 10 rural counties in New York. Dr. Dutkowsky wanted to see images of the patient and x-rays of the injuries from rural hospitals in order to determine what treatments were appropriate to provide locally and which cases needed immediate transfer and subsequent treatment from an orthopaedic surgeon.<sup>19</sup> Still image phones allowed the user to capture images using a regular camcorder by pressing a button on the phone to “capture” a single image. The device could hold multiple captured images. When the rural provider was ready to send an image, he or she simply pressed the send button and a single image was transmitted over a single phone line in less than 30 seconds. The telecommunications infrastructure used to support this telemedicine network was POTS. In these rural communities, the phone lines provided only 20-40 Kbps. However the still image phones transmitted data at only 14.4 Kbps. This

seemed a good match between the available infrastructure and the transmission equipment. Remote sites were often staffed by a physician's assistant (PA), especially at night. The ability to call a specialist on the phone and then to simultaneously transmit high quality, still images, provided a level of communication that had not existed previously.

Dr. Dutkowsky performed more than 100 consultations using this system.<sup>19</sup> On one winter 's night, during a severe snowstorm, Dr. Dutkowsky received a phone call from a PA in Cobleskill, NY, located 30 miles from Cooperstown, NY. A child with an injured leg was in the emergency department. The PA asked if an ambulance should be called to transport the child to Bassett Health Care. Dr. Dutkowsky looked at still images of the child, the leg, and radiographs of the leg. He determined that the child had suffered a fibular fracture. However, Dr. Dutkowsky did not see a need to risk transporting the child in such severe winter conditions. Instead he gave the PA specific instructions on how to cast the leg and asked the parents to bring the child to his clinic a week later. The ability to see images transmitted over phone lines provided enough information for decisions to be made that avoided patient transfers, while improving the quality of care in rural hospitals.<sup>19</sup>

### **C. University of Tennessee Trauma Project**

In 1995, Dr. Sam Burgiss, at the University of Tennessee in Knoxville, Tennessee, sought to address discrepancies in rural trauma care with a technological solution.<sup>20</sup> Still images captured with a hand-held camcorder from the scene of an accident, as well as from a rural emergency room, could be rapidly transmitted over cell phones to the Level 1 Trauma center in Knoxville to provide the trauma surgeons with additional critical information.

A grant to begin the project was awarded in 1997. Unfortunately, the technology had changed somewhat between the application and the award, and the original (simpler) product was no longer available. The project began with a combination of

a digital camera, laptop computer, and cell phone. This proved cumbersome and the cell phone bandwidth was inadequate so that data was lost in transmission.

At the same time, interactive video communication was set up between two rural emergency rooms and the trauma center, not unlike that described above at FAHC. However, the attitudes of physicians at the rural sites were vastly different. In this case, the emergency room doctors were “contractors” and had little interest in the goals of hospital administrators or the Level 1 Trauma Center surgeons. Those physicians did not like to take time to consult with others and, it seems, the contractors were not fully informed about the project. Ultimately, the two hospitals were bought by a competing health care system and the project was discontinued.

Dr. Burgiss points out that the failure of this project can serve as learning experience.<sup>20</sup> In general, matching the technology to the need is a difficult aspect of any telemedicine project. Clearly, the technology did not meet the needs in the digital image part of the project, and cellular technology was not up to the task *at that time*. The interactive video project failed because of “people factors”. There was not a physician leader at the rural hospitals nor was there a good understanding of how the project could help care for patients. Perhaps a “contract employee” is not as invested in the hospital’s successes and projects as a full time physician might be. Personnel education, and securing physician buy-in and administrator support is a labor-intensive undertaking.

#### **D. University of Missouri Emergency Telemedicine Experience**

Several years ago, the University of Missouri telemedicine program experimented with interactive video to the emergency room from rural sites. At that time, they adapted existing videoconferencing systems (VTEL, Austin, TX) to a rolling cart, trying to maximize the utility of expensive equipment (at that time approximately \$80,000). The systems could be moved from room to room (outpatient, conference room, emergency room, etc.) as the need dictated. As suggested above, however, portable equipment for emergency consults leads to the potential for equipment

failure, and this was experienced at the University of Missouri as equipment was moved from room to room. However, with that price point, it was hard to make a business case to have an expensive, low-volume system solely for the emergency department.

The videoconferencing system, particularly by today's standards, was difficult to use, requiring a tablet and digital pen, which took the doctor away from the injured or sick patient. The ED staff, which rotated regularly, had to be trained in the rather complex use of the devices, making the whole experience cumbersome. However, these aspects emphasize the technical aspects of emergency telemedicine. The urgency and unpredictability of the clinical situation precludes waiting for technical help or for a technically cumbersome system to work.

Human factors affected the University of Missouri program as well. Rural hospital sites were largely staffed by contract physicians so that there was little consistency at those sites. Given the additional technical training necessary and the relatively low volume of use, it would obviously add to the difficulty of transferring or consulting, especially when a telephone call worked well. The system at that time was designed to help with determining appropriate transfers where, in a retrospective view, transfers appeared to be largely appropriate. Thus, the system was expected to meet a perceived need that the clinicians did not feel existed. Thus, because of these huge technical limitations and problems as well as some human factors, the University of Missouri emergency program did not thrive and the effort was abandoned, with lessons learned.

#### **E. Emergency Telemedicine at Erie County Medical Center**

The emergency medicine program at the State University of New York at Buffalo and Erie County Medical Center (ECMC) began in 1992 and has become the busiest program in the country.<sup>6</sup> More than 2000 cases per year are seen by emergency providers from ECMC to rural emergency rooms as well as multiple State and Federal prison sites.

In this case, Dr. David Ellis developed a program that had incremental increases in volume and types of activity. In 1993, ECMC had a single link to a rural community hospital for rehabilitation physicians and therapists. This expanded in 1994 when Dr. Ellis established a PC-based link to a prison facility in Erie County for the purpose of patient evaluation and to try to avoid transportation of prisoners. The practicality and utility of using the technology to avoid trips to the emergency department led to implementing the program at three additional facilities.<sup>6</sup>

The next step was to support a rural four-bed hospital emergency room.<sup>6</sup> The emergency department was staffed during daylight hours with a physician's assistant and at night with a nurse and paramedic. Using telemedicine, emergency medicine physicians at ECMC provided support for this hospital, significantly decreasing the transfer rate.<sup>21</sup>

The program at ECMC recognized the importance of providing 24-hour-a-day, 7-day-a-week coverage for emergency care.<sup>6</sup> This was a high priority along with measuring outcomes (for example, return visits compared to standard emergency room care return visits) and documenting significant cost-savings. Technology was selected to limit expenses while maximizing value. With this careful, incremental approach, the ECMC telemedicine program has grown from a single site, single application (rehabilitation) to provide emergency coverage 24-hours-a-day to multiple facilities as well as educational programs and at least six other specialties. Well-defined goals, incremental development, and a defined response to need (decrease costs and transport) all led to the overwhelming success of this project.

## V. Useful References

1. *Accidental Death and Disability: The Neglected Disease of Modern Society*. Washington DC: National Research Council Committee on Trauma, National Academy of Sciences, National Research Council, National Academy of Sciences. September, 1966.

2. Rogers FB, Shackford SR, Osler TM, et al: Rural Trauma: The Challenge for the Next Decade. *J Trauma* 1999;47:802-21.
3. *Rural Emergency Medical Services: Special Report US*. Washington, DC: Congress Office of Technology Assessment; 1989. Publication OTA-H-445.
4. Morris TJ, Rapp T, Hendricks C, et al: Battlefield hands free speech capable point of care PDA's using automatic speech recognition. *Telemed J e-Health*, 2003; 9(Supp. 1):S38.
5. Joint Commission on Accreditation of Healthcare Organizations: Hospital Draft Standards. Telemedicine Services Standards, [http://www.jcaho.org/accredited+organizations/hospitals/standards/draft+standards/hap\\_mstelemed\\_fr\\_stds.pdf](http://www.jcaho.org/accredited+organizations/hospitals/standards/draft+standards/hap_mstelemed_fr_stds.pdf), May 17, 2003.
6. Ellis DG, Mayrose J, Jehle VK, et al: A telemedicine model for emergency care to a short-term county correctional facility. *Telemed J e-Health* 2001; 7:87-92.
7. Ellis DG, Mayrose J: The success of emergency telemedicine at the State University of New York at Buffalo. *Telemed J e-Health* 2003; 9:73-79.
8. Reid J: *A Telemedicine primer: Understanding the Issues*. Innovative Medical Communications, 1996, p. 195.
9. Ricci MA, Callas PW, Montgomery WL: The Vermont telemedicine project: Initial implementation phases. *Telemed J* 1997;3:197-205.
10. Callas PW, McGowan JJ, Leslie KO. Provider attitudes toward a rural telepathology program. *Telemed J* 1996;2:319-329.
11. Callas PW, Leslie KO, Mattia AR, et al. Diagnostic accuracy of a rural live video telepathology system. *Am J Surg Pathol* 1997;21:812-819.
12. Moses PL, McGowan JJ, Ricci MA: Efficacy of tele-endoscopy in a rural capitated market *Proc AMIA Annual Fall Symp* 1997;398-402.
13. Ricci MA, Knight SJ, Nutter B, Callas PW: Desktop telemedicine in vascular surgery: Some preliminary findings. *Telemed J* 1998;4:279-285.
14. Reid JG, McGowan JJ, Ricci MA, McFarlane G: Desktop teleradiology in support of rural orthopedic trauma care. *Proc AMIA Annual Fall Symp* 1997;403-7
15. Rogers FB, Ricci MA, Shackford SR, Caputo M, et al: The Use of Telemedicine for Real-Time Video Consultation Between Trauma Center and Community Hospital in

- a Rural Setting Improves Early Trauma Care: Preliminary Results. *J Trauma* 2001;51:1037-1041.
16. Ricci MA, Caputo M, Amour J, Rogers FB, et al: Telemedicine Reduces Discrepancies in Rural Trauma Care. *Telemed J e-Health* 2003;9:3-11.
  17. Personal Communication. Vermont: Department of Health Emergency Medical Services Division; 1998.
  18. Doheny-Farina S, Callas PW, Ricci MA, Caputo MP, Amour JL, Rogers FB: Technical Communication and Clinical Health Care: Improving Rural Emergency Trauma Care Through Synchronous Videoconferencing. *J Tech Writing Comm* (in press), 2003.
  19. Personal Communication. Dr. Joseph Dutkowsky, Bassett Health Care, May, 2003.
  20. Personal Communication. Dr. Samuel Burgiss, University of Tennessee, April, 2003.
  21. Ellis DG, Jehle D, Moscati R, et al: Initial experience with rural hospital emergency telemedicine night coverage using an on-site RN and paramedic team. *Acad Emerg Med* 1998;5:537.
  21. Baker SP, O'Neill B, Haddon W Jr, Long WB: The Injury Severity Score: a method for describing patients with multiple injuries and evaluating emergency care. *J Trauma* 1974;14:187-96.
  22. Ricci MA: Using Telemedicine to Care for Rural Trauma Patients. Presented at the annual meeting of the American Telemedicine Association , Orlando, Florida, April 28, 2003.

### Documents & Websites

1. Ellis DG, Jehle D, Moscati R, et al: Initial experience with rural hospital emergency telemedicine night coverage using an on-site RN and paramedic team. *Acad Emerg Med* 1998;5:537.
2. Ellis DG, Mayrose J, Jehle VK, et al: A telemedicine model for emergency care to a short-term county correctional facility. *Telemed J e-Health* 2001; 7:87-92.



3. Ellis DG, Mayrose J: The success of emergency telemedicine at the State University of New York at Buffalo. *Telemed J e-Health* 2003; 9:73-79.
  4. Reid JG, McGowan JJ, Ricci MA, McFarlane G: Desktop teleradiology in support of rural orthopedic trauma care. *Proc AMIA Annual Fall Symp* 1997;403-7
  5. Rogers FB, Shackford SR, Osler TM, et al: Rural Trauma: The Challenge for the Next Decade. *J Trauma* 1999;47:802-21.
  6. Ricci MA, Caputo M, Amour J, Rogers FB, et al: Telemedicine Reduces Discrepancies in Rural Trauma Care. *Telemed J e-Health* 2003;9:3-11.
  7. Rogers FB, Ricci MA, Shackford SR, Caputo M, et al: The Use of Telemedicine for Real-Time Video Consultation Between Trauma Center and Community Hospital in a Rural Setting Improves Early Trauma Care: Preliminary Results. *J Trauma* 2001;51:1037-1041.
- American Telemedicine Association: <http://www.atmeda.org>
  - Telemedicine Journal and e-Health:  
<http://www.liebertpub.com/TMJ/default1.asp>
  - Technologies Opportunities Program:  
<http://www.ntia.doc.gov/top/conferenceworkshops/nfp2001/NFP2001.html>
  - Telemedicine Information Exchange: <http://tie.telemed.org/>
  - Military Telemedicine: <http://www.tatrc.org>
  - American College of Surgeons: <http://www.facs.org>

## VI. Sample Protocols and Documents

### A) Tele-trauma Call Schedule

Practice

Name: TeleTrauma Attending

Name of person submitting sched: Rejeanne Jalbert

Schedule for the month of June

E-mail this schedule and updates to  
On-Call Sched (from outside FAHC,  
e-mail PAS@vtmednet.org)

Service (Specify)		Day 8-5		Eve / Nite	
		First Call	Second Call	First Call	Second Call
1	Sat	Sartorelli	Rogers	Sartorelli	Rogers
2	Sun	Sartorelli	Rogers	Sartorelli	Rogers
3	Mon	Rogers	Ricci	Rogers	Ricci
4	Tue	Rogers	Ricci	Rogers	Ricci
5	Wed	Rogers	Ricci	Rogers	Ricci
6	Thu	Rogers	Ricci	Rogers	Ricci
7	Fri	Rogers	Ricci	Rogers	Ricci
8	Sat	Rogers	Ricci	Rogers	Ricci
9	Sun	Rogers	Ricci	Rogers	Ricci
10	Mon	Rogers	Ricci	Rogers	Ricci
11	Tue	Rogers	Ricci	Rogers	Ricci
12	Wed	Rogers	Ricci	Rogers	Ricci
13	Thu	Ricci	Sartorelli	Ricci	Sartorelli
14	Fri	Ricci	Sartorelli	Ricci	Sartorelli
15	Sat	Ricci	Sartorelli	Ricci	Sartorelli
16	Sun	Ricci	Sartorelli	Ricci	Sartorelli
17	Mon	Sartorelli	Rogers	Sartorelli	Rogers
18	Tue	Sartorelli	Rogers	Sartorelli	Rogers
19	Wed	Sartorelli	Rogers	Sartorelli	Rogers
20	Thu	Sartorelli	Rogers	Sartorelli	Rogers
21	Fri	Sartorelli	Rogers	Sartorelli	Rogers
22	Sat	Sartorelli	Rogers	Sartorelli	Rogers
23	Sun	Sartorelli	Rogers	Sartorelli	Rogers
24	Mon	Rogers	Ricci	Rogers	Ricci
25	Tue	Rogers	Ricci	Rogers	Ricci
26	Wed	Rogers	Ricci	Rogers	Ricci
27	Thu	Rogers	Ricci	Rogers	Ricci
28	Fri	Rogers	Ricci	Rogers	Ricci
29	Sat	Rogers	Ricci	Rogers	Ricci
30	Sun	Rogers	Ricci	Rogers	Ricci

**B) Contact List**

**TELEMEDICINE TRAUMA CONTACT LIST**  
**Fletcher Allen Health Care**  
**Provider Access Service (PAS): 800-639-xxxx**

**Medical Points of Contact:**

Michael A. Ricci, M.D. (Contact through PAS)  
 Frederick Rogers, M.D. (Contact through PAS)  
 Kenneth Sartorelli, M.D. (Contact through PAS)

**Video/Telephone Numbers**

<b>Trauma Surgeon Home</b>	<b>Video Number</b>	<b>Telephone</b>
Michael A. Ricci, M.D.:	802-658-xxxx	Call PAS
Frederick Rogers, M.D.:	802-657- xxxx	Call PAS
Kenneth Sartorelli, M.D.:	802-879- xxxx	Call PAS
<b>FAHC Telemedicine Rooms</b>	<b>Video Number</b>	<b>Telephone</b>
Telemedicine Room (MCHV Campus):	802-651- xxxx	802-656- xxxx
Michael Ricci's Office, (UHC Campus):	802-651- xxxx	802-847- xxxx
<b>Remote Site ER Trauma Rooms</b>	<b>Video Numbers</b>	<b>ER Telephone</b>
Alice Hyde Hospital, Malone, NY:	518-566- xxxx	518-483- xxxx
Canton-Potsdam Hospital, Potsdam, NY:	315-268- xxxx	315-265- xxxx
Copley Hospital, Morrisville, VT:	802-229- xxxx	802-888- xxxx
Massena Memorial Hospital, Massena, NY:	315-769- xxxx	315-769- xxxx

**Technical Points of Contact: DAYS 7:30am-4:30pm**

FAHC:	Harry Clark	(802) 847-xxxx /pager 802-847-xxxx
	Cc Irish	(802) 847-xxxx/pager 802-847-xxxx
	Steve Taylor	(802) 847-xxxx/pager 802-847-xxxx
	Michael Caputo	(802) 847-xxxx/Call PAS
Alice Hyde:	Dave E.	(518) 483-xxxx x
Canton-Potsdam:	Michael P.	(315) 265-xxxx

**EVENINGS & WEEKENDS**

FAHC:	Michael Caputo	Call PAS
	Michael Ricci	Call PAS

## C) Trauma Participation Guidelines

1/13/04

### Teletrauma Participation Guidelines

#### Individuals Involved in Teletrauma

Fred Rogers (Director)  
 Bill Charash  
 Mike Ricci  
 Ken Sartorelli  
 Spring 2004)

Dennis Vane  
 Bruce Tranmer  
 Mike Horgan  
 Bruce Crookes (anticipated,

#### Definition of “Involvement”

Individuals in the teletrauma program have made a commitment to *fully* participate in the program. This means these individuals have technical training, know where telemedicine sites are available on campus, understand how to obtain technical help, know the hospitals participating, know procedures for trauma care and teletrauma, and have operational videoconferencing systems in their homes. They will be available to help, even when not on teletrauma call.

#### Sites Where Teletrauma is Available (see map)

Alice Hyde Hospital (Malone, NY)  
 Canton-Potsdam Hospital (Potsdam, NY)  
 Massena Memorial Hospital (Massena, NY)  
 Adirondack Medical Center (Saranac Lake, NY)  
 Lake Placid Health Center (Lake Placid, NY) (anticipated)  
 Moses Luddington Hospital (Ticonderoga, NY)  
 Porter Hospital (Middlebury, VT)  
 Copley Hospital (Morrisville, VT)  
 Rutland Regional Medical Center (Rutland, VT) (anticipated)

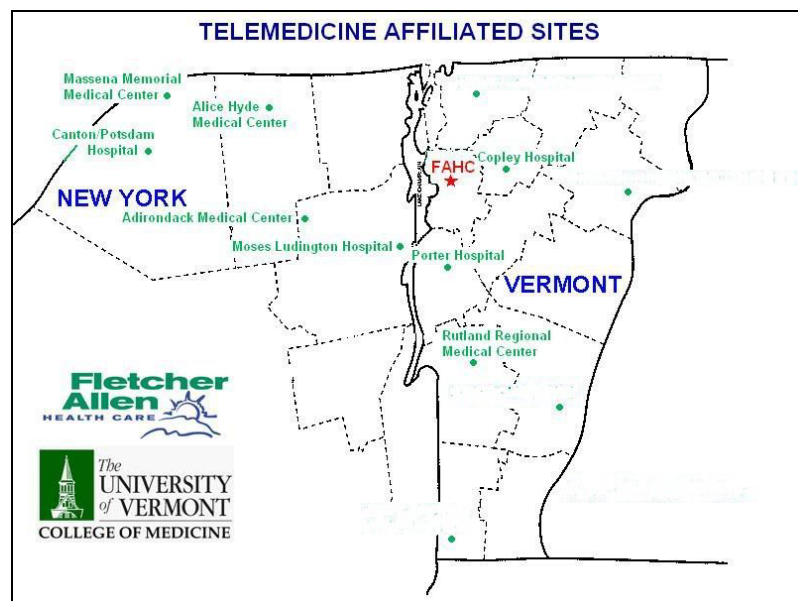

## Call Schedules

- 1 - A teletrauma call schedule will be produced each month by Dr. Rogers' office. It will be produced in the same fashion as the regular trauma call schedule.
- 2 - Whenever possible, the trauma service attending on call for *trauma* will be the same individual on call for teletrauma. Thus, each of the trauma surgeons will be on call for both trauma and teletrauma whenever they are on call. (When all 3 trauma surgeons are "wired", the need for others to take teletrauma call will be reduced.)
- 3 - When those individuals are unavailable or unable to respond to the "teletrauma call" (i.e., they are in the OR and unable to get to a location with telemedicine equipment), the trauma service attending on *back up trauma call* will be contacted.
- 4 - When the individual on trauma call that does not have telemedicine access (see list above), the trauma backup call person will be the first individual contacted to handle the teletrauma.
- 5 - If the first call for trauma is unavailable (or does not have telemedicine access) and the backup trauma call person is unavailable or does not have access (i.e., the vascular surgeons except for Ricci do not), then calls should be made in the following order:
  - 1) Fred Rogers (Director)
  - 2) Bill Charash
  - 3) Bruce Crookes (when available)
  - 4) Mike Ricci
  - 5) Ken Sartorelli
  - 6) Dennis Vane
  - 7) Bruce Tranmer
  - 8) Mike Horgan
- 6 - Provider Access Service (PAS) will be the primary point of contact for teletrauma emergency calls. They will refer to the teletrauma call schedule and call in the following order: teletrauma call person, backup trauma call (if the individual participates in teletrauma programs), and then individuals on the list above, in order. It is expected that this situation will arise only during daytime hours or if the primary call individual is in the OR. *It is expected that teletrauma call is treated with the same seriousness as any other call schedule.*

## Trauma Telephone Calls from Participating Hospitals

The FAHC Trauma Service will enact a *policy* stating that telephone calls from any hospital site participating in teletrauma will be followed with an immediate teletrauma/telemedicine call back to that hospital. Should a surgeon be on trauma call that does not have telemedicine capability, it will be his or her responsibility to have PAS contact the teletrauma surgeon on call, as described above. This policy will be refined and distributed to FAHC surgeons and outside sites by Dr. Rogers and Dr. Ricci.

## Technical Support

During normal work hours, telemedicine technical support can be reached through PAS (847-2700). After hours, have PAS contact Dr. Ricci or Michael Caputo.

## Specialty Care

Selected specialists in Neurosurgery, Vascular Surgery, and Pediatric Surgery participate in the teletrauma program. They may be requested to participate (if available) in the care of an injured patient who has an injury involving their area of expertise. Any such request to act as a telemedicine specialist (and not primarily as the teletrauma specialist) will come from the teletrauma attending responding to the teletrauma emergency.

## Teleradiology

A large Radiology group in northern NY has teleradiology capability (direct viewing of CT scans and X-rays) and has made that available to us. Participants in the teletrauma program have direct web-based teleradiology capability on their home computers, in the telemedicine room on the MCHV campus and room G422A on the UHC campus. The hospitals offering this service (not limited to trauma patients) are Canton-Potsdam Hospital and Massena Memorial Hospital.

## Teletrauma Paperwork

To track our use and quality of the teletrauma program, we ask that you complete a teletrauma evaluation form (attached) and return to Judy Amour on the UHC campus (Room G400C).

## Documentation for Teletrauma Consults

It is required that a note is generated after each teletrauma contact, whether or not a bill is submitted. This is for medical and legal reasons (i.e., it is good medical practice to document a patient encounter). Simply dictate the aspects of the history, vital signs, and physical exam (and/or X-rays) in which you were able to participate (some of us take notes on the teletrauma evaluation form above and dictate a note from that later).

The note or dictation should include the following phrase (recommended by FAHC Compliance):

*Interactive audio and video telecommunications were used, permitting real-time communication between the distant site physician (or provider) and the patient. Both were present and participated in the telehealth visit.*

Send copies to MCHV, the referring doctor or hospital, and the admitting trauma surgeon (if applicable).

### **Billing for Teletrauma Consults**

It is appropriate to bill for a teletrauma consult, unless the consult was initiated by you instead of a referring hospital/physician. CPT codes 99241–99275 are applicable, though it is hard to reach the higher level codes with the technology imposed limitations in the physical examination. Telehealth claims submitted must have the appropriate CPT code for the professional service provided, *as well as the telehealth modifier “GT”*, which designates “via interactive audio and video telecommunication system”. Documentation is especially important when bills are submitted, as you know.

### **Legal Issues**

FAHC covers physicians participating in telemedicine in the same fashion as in-person coverage.

### **Licensure Issues**

The NY State licensure statute allows that an individual without a NY State license may consult on a patient in NY if requested to do so by a licensed physician in NY. This covers the occasional NY state consult some of you will do. It is recommended that if any volume of consults are anticipated (i.e., trauma surgeons), a NY State license should be obtained.

**D) Tele-Trauma Consult Data Form**

Date of Consult: \_\_\_\_\_ Time of Consult: \_\_\_\_\_

Patient name: \_\_\_\_\_ Date of Birth: \_\_\_\_/\_\_\_\_/\_\_\_\_  
Last First MM DD YYYY

**Referring Physician name:** \_\_\_\_\_

Trauma surgeon:

Horgan       Ricci       Rogers

Sartorelli       Tramner       Vane       Other (specify):  
\_\_\_\_\_

From what location did you initiate the call? home:\_\_\_ tmed. rm:\_\_\_  
other:\_\_\_\_\_

Referring hospital:

Alice Hyde       AMC       Canton-Potsdam       Copley

Massena       Moses Ludington       Porter       Rutland

Other (specify): \_\_\_\_\_

Injuries identified:

1. \_\_\_\_\_

2. \_\_\_\_\_

3. \_\_\_\_\_

4. \_\_\_\_\_

5. \_\_\_\_\_

Mechanism of injury:

\_\_\_\_\_

Lowest B.P. \_\_\_\_ / \_\_\_\_      Highest P \_\_\_\_\_      Highest RR \_\_\_\_\_      GCS \_\_\_\_\_



Questions from referring provider:

1. \_\_\_\_\_
2. \_\_\_\_\_
3. \_\_\_\_\_
4. \_\_\_\_\_
5. \_\_\_\_\_
6. \_\_\_\_\_
7. \_\_\_\_\_

Advice given by trauma surgeon (check all that apply):

- |   |   |
|---|---|
| <input type="radio"/> Send patient to FAHC -- routine | <input type="radio"/> Place chest tube                  |
| <input type="radio"/> Send patient to FAHC -- ASAP    | <input type="radio"/> Do CT                             |
| <input type="radio"/> Keep at referring facility      | <input type="radio"/> Do not do CT                      |
| <input type="radio"/> Place NG                        | <input type="radio"/> Give blood                        |
| <input type="radio"/> Intubate                        | <input type="radio"/> Explore abdomen prior to transfer |
| <input type="radio"/> Other (specify): _____          |   |
| <input type="radio"/> Other (specify): _____          |   |
| <input type="radio"/> Other (specify): _____          |   |

Transfer?  Yes  No

If yes, reason:

- Unstable  Ortho surgeon unable to care for injury  
 No ICU bed  Limited blood bank  
 No neurosurgeon available  
 Other (specify): \_\_\_\_\_

Mode of transport:  Ground  Helicopter  Fixed wing

Teleradiology used?  Yes  No

If yes:

Xrays reviewed

- Plain films  CT of chest  
 CT of head  CT of abdomen & pelvis  
 Other (specify): \_\_\_\_\_

Quality of xrays  Good  Fair  Poor

Did teleradiology change clinical care?  Yes  No

If yes, what was changed

- Decision to operate prior to transfer  
 Decision to transfer  
 Additional procedure (specify): \_\_\_\_\_  
 Other (specify): \_\_\_\_\_

## Evaluation Questions:

1. This consult improved the quality of this patient's health care.  
 Strongly Agree    Agree    Neither agree nor disagree    Disagree    Strongly disagree
2. This consult could have been performed as well by telephone.  
 Strongly Agree    Agree    Neither agree nor disagree    Disagree    Strongly disagree
3. The ease of use of the telemedicine equipment was:  
 Very good    Good    Adequate    Poor    Very poor
4. The quality of the video was:  
 Very good    Good    Adequate    Poor    Very poor
5. The quality of the audio was:  
 Very good    Good    Adequate    Poor    Very poor
6. Referring provider/trauma surgeon communication during this session was:  
 Very good    Good    Adequate    Poor    Very poor

### **E) Sample Tele-Trauma Protocol**

The Telemedicine Trauma Consult Criteria provided on the next page was developed by Dr. Frederick Rogers, Director of Trauma, at Fletcher Allen Health Care.<sup>16</sup> This document was printed as a poster and displayed on the wall of each participating ED.



## Telemedicine TRAUMA Consult Criteria:\*

Any one of the following:

- 1. GCS  $\leq$  13
- 2. Hypotension (systolic BP  $<$  90 mmHg)
- 3. Penetrating truncal trauma
- 4. Respiratory Distress ( $10 >$  RR  $<$  30)
- 5. Amputation proximal to the wrist or ankle.
- 6. Any patient not meeting the above criteria for whom the treating physician feels it is appropriate to call a telemedicine consult.

*\* These criteria will be based on the patient's initial presentation to the facility and not on vitals taken in the field. It is appropriate to call a teleconsult prior to patient arrival if, in the opinion of the treating physician, the patient is likely to meet criteria.*

# Provider Access Service:

## 800 639-XXXX

*Ask for*

**Trauma Telemedicine Consult**

*(Be certain to identify  
your calling location.)*

### Telehealth and Telecommunication Definitions

The terms “telehealth”, “telemedicine”, “consultation” and “encounter” were provided in the introduction section of this document. However, there are many other definitions related to telehealth, telemedicine and telecommunications with which the reader needs to be familiar. Below are two sets of definitions for individuals involved in the provision of telehealth services. The first set of definitions provide terms that are common in the telehealth world. They are non-technical and the reader may find the terms throughout the various sections of this document.

The second set of definitions provides common terms related to telecommunications and networking. This set is much longer than the first, because most of the telecommunication and networking terms are foreign to many health care professionals. However, its is important for any health care professional embarking on a telehealth project to have a general understanding of these terms when talking with telecommunications companies or the technical staff within their facility.

Both sets of definitions are written in layman’s terms and by no means do they cover all clinical or technical terms related to telehealth. Below are a few additional sources of definitions:

- Federal Standard 1037C - Glossary of Telecommunication Terms
  - <http://glossary.its.bldrdoc.gov/fs-1037/> (accessed 6/8/04)
- Newton’s Telecom Dictionary, CMP Books; 16<sup>th</sup> edition.
- WireOne Videoconferencing Glossary
  - [http://www.wireone.com/support\\_glossary.html](http://www.wireone.com/support_glossary.html) (accessed 6/8/04)
- Association of Telehealth Service Providers – Telemedicine Glossary
  - <http://www.atsp.org/telemedicine/glossary.asp> (accessed 6/8/04)

**TELEMEDICINE/TELEHEALTH TERMS (in alphabetical order):**

*Distant Site:*

The Centers for Medicare and Medicaid Services (CMS) define the distant site as the telehealth site where the provider/specialist is seeing the patient at a distance or consulting with a patient's provider. Other common names for this term include – hub site, specialty site, provider/physician site and referral site.

*Digital Camera (still images):*

A digital camera is typically used to take still images of a patient. General uses for this type of camera include dermatology and wound care. This camera produces images that can be downloaded to a PC and sent to a provider/consultant over a network.

*Document Camera:*

A camera that can display written or typed information (e.g., lab results), photographs, graphics (e.g., EKG strips) and in some cases X-Rays.

*Originating Site:*

CMS defines originating site as the site where the patient and/or the patient's physician is located during the telehealth encounter or consult. Other common names for this term include – spoke site, patient site, remote site, and rural site.

*Patient Exam Camera (video):*

This is the camera typically used to examine the general condition of the patient. Types of cameras include those that may be embedded with set-top videoconferencing units, handheld video cameras, gooseneck cameras, camcorders, etc. The camera may be analog or digital depending upon the connection to the videoconferencing unit.

*Presenter (Patient Presenter):*

Telehealth encounters require the distant provider to perform an exam of a patient from many miles away. In order to accomplish that task an individual with a clinical background (e.g., LPN, RN, etc) trained in the use of the equipment must be available at the originating site to “present” the patient, manage the cameras and perform any “hands-on” activities to successfully complete the exam. For example, a neurological diagnostic exam usually requires a nurse capable of testing a patient’s reflexes and other manipulative activities. It should be noted that in certain cases (e.g., some dermatology or mental health encounters) a presenter with a clinical background is not always necessary, because the encounter may only require camera management skills.

*Rural Health Care Division (RHCD):*

RHCD is a component of the Universal Service Administrative Company (USAC). The RHCD manages a universal service support mechanism that provides reduced rates to rural Health Care Providers (HCPs) for telecommunications and Internet services necessary for the provision of health care.

*Store and Forward (S&F):*

S&F is a type of telehealth encounter or consult that uses still digital images of a patient for the purpose of rendering a medical opinion or diagnosis. Common types of S&F services include radiology, pathology, dermatology and wound care. Store and forward also includes the asynchronous transmission of clinical data, such as blood glucose levels and electrocardiogram (ECG) measurements, from one site (e.g., patient’s home) to another site (e.g, home health agency, hospital, clinic).

*Universal Service Administrative Company (USAC):*

The Universal Service Administrative Company administers the Universal Service Fund (USF), which provides communities across the country with affordable telecommunication services. The Rural Health Care Division (RHCD) of USAC manages the telecommunications discount program for health care.



## **TELECOMMUNICATION/NETWORKING TERMS:**

### *Asynchronous:*

This term is sometimes used to describe store and forward transmission of medical images or information because the transmission typically occurs in one direction in time. This is the opposite of synchronous (see below).

### *Channel Service Unit (CSU):*

A CSU is a piece of equipment used to connect a digital phone line (e.g. T1 line) to multiplexers, routers, or some other device producing a digital signal. It is typically the first piece of equipment that is connected to the digital telecommunications line in the facility. A CSU performs certain line-conditioning functions that may be required by the videoconferencing or network device. The CSU will also indicate if the line is functioning properly. A CSU can be a stand alone device or it may be integrated into a router.

### *CODEC:*

Acronym for coder-decoder. This is the videoconferencing device (e.g., Polycom, Tandberg, Sony, Panasonic, etc) that converts analog video and audio signals to digital video and audio code and vice versa. CODECs typically compress the digital code to conserve bandwidth on a telecommunications path.

### *Demarcation Point (DMARC):*

This is the point in the facility where the telecommunication company terminates the telecommunications circuit. In many instances the DMARC for telehealth networks can be found in the telecommunications closet of the health care facility.

### *H.320:*

This is the technical standard for videoconferencing compression standards that allow different equipment to interoperate via T1 or ISDN connections.

*H.323:*

This is the technical standard for videoconferencing compression standards that allow different equipment to interoperate via the Internet Protocol (see below).

*H.324:*

This is the technical standard for videoconferencing compression standards that allow different equipment to interoperate via Plain Old Telephone Service (POTS).

*HUB:*

This is a device that allows a single network connection to be distributed to other network devices (e.g., PCs, printers) via multiple ports. This device is also known as a concentrator.

*Interactive Video/Television:*

This is analogous with video conferencing technologies that allow for two-way, synchronous, interactive video and audio signals for the purpose of delivering telehealth, telemedicine or distant education services. It is often referred to by the acronyms – ITV, IATV or VTC (video teleconference).

*Integrated Services Digital Network (ISDN):*

This is a common dial-up transmission path for videoconferencing. Since ISDN services are used on demand by dialing another ISDN based device, per minute charges accumulate at some contracted rate and then are billed to the site placing the call. This service is analogous to using the dialing features associated with a long distance telephone call. Who ever dials, pays the bill.

*ISDN Basic Rate Interface (BRI):*

This is an ISDN interface that provides 128k of bandwidth for videoconferencing or simultaneous voice and data services. Multiple BRI lines can be linked together using a multiplexer (see below) to achieve higher bandwidth levels. For instance, a

popular choice among telehealth networks is to combine 3 BRI lines to provide 384k of bandwidth for video-conferencing. It should be noted that BRI services are not available in some rural locations. One should check with their telecommunications providers on the availability of BRI service before ordering videoconferencing equipment that uses this type of service.

*ISDN Primary Rate Interface (PRI):*

This is an ISDN interface standard that operates using 23, 64k channels and one 64k data channel. With the proper multiplexing equipment the ISDN PRI channels can be selected by the user for a video call. For instance if the user wants to have a videoconference at 384k of bandwidth then they can instruct the multiplexer to use channels 1 through 6 ( $6 \times 64k = 384k$ ). This is important because the user typically pays charges based on the number of 64k channels used during a videoconference. The fewer channels used to obtain a quality video signal the less expensive the call.

*Internet Protocol (IP):*

IP is part of the protocols describing the software that tracks the Internet address of outgoing and incoming messages. Most of today's videoconferencing devices have the capability to use IP as a video protocol (see H.323 above). The IP address of a videoconferencing system is its phone number.

*Multiplexer (MUX):*

A device that combines multiple inputs (ISDN PRI channels or ISDN BRI lines) into an aggregate signal to be transported via a single transmission path.

*Multipoint Control Unit (MCU):*

A device that can link multiple videoconferencing sites into a single videoconference. An MCU is also often referred to as a "bridge".

*POTS:*

Acronym for Plain Old Telephone Service

*Router:*

This is a device that interfaces between two networks or connects sub-networks within a single organization. It routes network traffic between multiple locations and it can find the best route between any two sites. For example: PCs or H.323 videoconferencing devices tell the routers where the destination device is located and the routers find the best way to get the information to that distant point.

*Smart Jack:*

This is what many telecommunication companies typically refer to as the piece of equipment that terminates the digital phone line at the DMARC (see above). This is where the phone company's responsibility ends. The smart jack feeds the digital signal to your CSU, router, etc. It is also used by the phone companies for diagnostics should the connection have problems. The smart jack can also automatically alert the phone company to problems on the circuit by setting off alarms in the central office of a phone company.

*Switch:*

A switch in the videoconferencing world is an electrical device that selects the path of the video transmission. It may be thought of as an intelligent hub (see hub above) because it can be programmed to direct traffic on specific ports to specific destinations. Hub ports feed the same information to each device.

*Synchronous:*

This term is sometimes used to describe interactive video connections because the transmission of information in both directions is occurring at exactly the same period.

*T1:*

A digital telecommunications connection running at 1.544 megabits per second.

### About the Authors

#### Mary Anders

Mary Anders is a Registered Nurse with over 30 years of nursing experience. She has worked in various clinical and management roles during her nursing career with over 16 years experience in home care. Prior to transferring to the University of Tennessee's Telehealth Network she was Associate Director of their home care agency. For the past 3.5 years she has worked with various clinics, home health agencies and other health entities in establishing and maintaining telehealth programs.

#### Howard C. Anderson

Howard C. Anderson, JR., R.PH, is Executive Director of the North Dakota State Board of Pharmacy in Bismarck, North Dakota. Mr. Anderson earned a Bachelors of Science in Pharmacy from North Dakota State University in Fargo, North Dakota in 1968. Since 1968, he has been a licensed pharmacist store owner of Turtle Lake Rexall Drug in Turtle Lake, North Dakota. From 1976 to 1996, he was the Pharmacist-In-Charge of Turtle Lake Community Memorial Hospital in Turtle Lake, North Dakota. Since 1976, he has been Co-Owner of Reynolds Drug in Helena, Montana. From 1993 to 1997, Mr. Anderson was Executive Vice President of the North Dakota Pharmacy Service Corporation and from 1991 to 1997, he was Executive Vice President of the North Dakota Pharmaceutical Association. Mr. Anderson has been Executive Director of the North Dakota State Board of Pharmacy since 1997. He is a registered pharmacist in the states of North Dakota and Montana.

#### Nina Antoniotti

Dr. Antoniotti is Marshfield Clinic TeleHealth Network's Program Director. She started her position with MCTN in 1997 after twenty years experience in hospital-based health care. Dr. Antoniotti's educational background includes a Diploma in Nursing (1976), a Bachelor in Management and Labor Relations (1988), a Masters in Business Administration (1992), and a Doctorate in Organizational Systems (2002). In 2001, Dr. Antoniotti received an award from the Office for the Advancement of TeleHealth, HRSA, for her pioneering efforts in the development of TeleHealth. She has been involved in the development of national technology and operational guidelines for TeleHealth standards and has presented at regional and national TeleHealth/Telemedicine and Technology conferences in the areas of integration, business plan development, clinical services, evaluation, HIPAA and TeleHealth, and needs assessments for TeleHealth.

Dr. Antoniotti is the current Chair of the American Telemedicine Policy Committee and is a Board Member of the Center for Telemedicine Law. She has served on the

Medical Advisory Group to Polycom and as a member of the Advisory Board for the TeleHealth Deployment Research Testbed, Advanced Technology Institute, Charleston, South Carolina.

### **David Batton**

David Batton is a Telecommunications Network Analyst for the Office of Telemedicine at the University of Virginia Medical Center, where he manages the wide area network for the Telemedicine program. David is a Cisco Certified Network Associate with over 10 years experience in the information technology industry, ranging from administering client/server architectures to designing converged voice, video, and data networks.

### **Larry Bettesworth**

Larry G. Bettesworth, PharmD. is the Director of Pharmacy at Sacred Heart Medical Center, Spokane, Washington. He holds Adjunct Faculty position in the Washington State College of Pharmacy and the University of Washington School of Medicine. Dr. Bettesworth is the current Director of the INHS Telepharmacy Program.

### **Sam Burgiss**

Sam Burgiss, Ph.D., is the Director of the University of Tennessee Telehealth Network (UTTN) at Knoxville. Under his direction, UTTN has provided over 90,000 patient encounters since the program began in 1995. Sam is the Secretary of the American Telemedicine Association (ATA) and is a member of the Board of Directors. He is a member of the ATA Executive Committee of the Business and Finance Special Interest Group, is a member of the ATA Policy Committee, and has served as Chair of the ATA Home Telehealth Special Interest Group for four years. He is a member of the Coalition for the Advancement of Telehealth. In May 2004, he received the Leadership Award for the Advancement of Telemedicine from the ATA.

Dr. Burgiss received his B.S., M.E.E., and Ph.D. degrees in Electrical Engineering from North Carolina State University. He has had over fifteen years of experience with engineering and marketing development of medical products in addition to ten years of telehealth experience.

### **Ann Bynum**

Ann Bynum, Ed.D, is the Director of the University of Arkansas Rural Hospital Telehealth Program and Associate Director for Program Development of the Arkansas Area Health Education Centers. She has overseen the implementation of an interactive video system at more than 50 rural sites and developed a system for scheduling, conducting, tracking, and evaluating telemedicine consultations. Under her direction, a consumer health education program has been developed that

delivers interactive presentations on various health topics to residents of rural communities.

Dr. Bynum is involved in telemedicine policy development at the state and national levels. She has served on the Southern Governor's Association Task Force on Medical Technology. She also serves on the Research and Evaluation Task Force of the American Telemedicine Association.

### **Michael Caputo**

Michael Caputo, M.S. is the Director of Information Systems and Telemedicine Operations at the University of Vermont, College of Medicine. For the last four years he has directed the implementation of a college-wide information systems department. In addition, he directs the telemedicine department, with links throughout the region to provide clinical consultation and educational events. In 2003 the College of Medicine implemented an online learning environment to support the Vermont Integrated Curriculum.

Previously, Mr. Caputo served as a Project Executive for the C. Everett Koop Institute, where he helped to develop telemedicine and medical informatics projects. Prior to that, he served as a Project Scientist at NASA's Johnson Space Center where he developed hardware and protocols for supporting telemedicine operations during Space Shuttle missions.

Mr. Caputo's work has earned him numerous awards including NASA Certificates of Recognition, a Leadership Award from the NASA Administrator, and two United States Patents. He received degrees from the Rochester Institute of Technology and the University of Houston.

### **Jan Constable**

Janet L. Constable, R.N., B.S.N. currently is the Grants Manager in the Program Development Office at Inland Northwest Health Services in Spokane, WA. Her responsibilities include the facilitation of the Telepharmacy program at INHS. Ms. Constable has worked within the Spokane health care system for the past 25 years and her experience includes clinical nursing, parent education, community health education, and program development.

### **Jac Davies**

Jac Davies is the Director of Program Development for Inland Northwest Health Services (INHS), a non-profit corporation providing information technology, telehealth, health education and other services to more than thirty hospitals and to other health care providers across eastern Washington and northern Idaho. Ms. Davies is responsible for identifying new opportunities for program growth and development, and new partnerships for INHS. Prior to joining INHS, Ms. Davies worked at the Washington State Department of Health, where she served as an assessment and information system coordinator and as Assistant Secretary for the

Division of Epidemiology, Health Statistics, and Public Health Laboratories. Ms. Davies has an MS and an MPH from the University of Washington, and a BS from the Mississippi University for Women.

### **Steve Dawson**

Steve Dawson received his Bachelor of Physical Therapy from the University of Missouri-Columbia. He is a clinical development specialist at INTEGRIS Jim Thorpe Rehabilitation Center and has a private physical therapy treatment practice. He is a national instructor for Neuro-Development Training (NDT) conducting over 50 of the three-week NDT training courses. He has been active in the field of telerehabilitation for five years, and serves as co-chair for the telerehabilitation special interest group for the American Telemedicine Association.

### **Susan Dimmick**

Susan Dimmick, PhD, joined the Oak Ridge Institute for Science and Education, a Department of Energy facility managed by Oak Ridge Associated Universities, as a Health Education Project Manager, in October 2004. She is the secretary for the Home Telehealth Special Interest Group (SIG) of the American Telemedicine Association and will become the vice chair of the SIG in January 2005. Recently, Dr. Dimmick was manager of evaluation and research for the UT Telehealth Network™. Knoxville. She has been involved with telehealth outcomes and evaluation research for more than eight years. She was a nurse for nearly 10 years. Dr. Dimmick has conducted evaluation research for three different projects funded by the Office for the Advancement of Telehealth, HRSA, Department of Health and Human Services. She has made numerous presentations and published a number of refereed journal articles and book chapters on telehealth outcomes and health care relationship management. Dr. Dimmick was a United States Information Agency (USIA) Academic Scholar and a U.S. Fulbright researcher and lecturer on distance education in Latin America.

### **Gary Doolittle**

Gary Doolittle, MD, is the medical liaison to the Center for Telemedicine and Telehealth. He is an Associate Professor of Clinical Oncology at Kansas University Medical Center and has conducted over 1,500 telemedical visits evaluating and managing patients with a wide variety of hematologic and oncologic disorders. Dr. Doolittle has authored publications concerning telemedicine delivery, cost analysis, and patient satisfaction. He has also been instrumental in the expansion of the Kansas telemedicine project through the development of additional services including journal club for physicians, patient education, support groups, and innovative programs such as TeleKidcare® and TeleHospice.



### **Joseph Dutkowsky**

Joseph Dutkowsky, MD is an attending surgeon in pediatric orthopedics at Bassett Healthcare in Cooperstown, NY. Dr. Dutkowsky earned his undergraduate degree from the Rensselaer Polytechnic Institute and his medical degree from Brown University. He completed an internship and residency at the Dartmouth-Hitchcock Medical Center and a fellowship in pediatric orthopedics at Boston Children's Hospital, Harvard University. He has served as a senior fellow to the C. Everett Koop Institute and is actively involved with the American Academy of Cerebral Palsy and Developmental Medicine.

Dr. Dutkowsky has been utilizing telemedicine since 1995, when he realized that it could be used as a tool to link him with patients in rural communities, thus improving access to health care and reducing patient and family travel. He has completed more than 100 teleconsultations using store and forward telemedicine systems as well as interactive video conferencing. His interests relate to improving the quality of care for children and adults with disabilities and their families.

### **Karen Edison**

Dr. Edison's current titles include the Philip C. Anderson Professor and Chairman of the Department of Dermatology, Medical Director of the Missouri Telehealth Network, and Co-Director of the Center for Health Policy at the University of Missouri in Columbia. She received her medical degree and served her residency in dermatology at the University of Missouri in Columbia where she joined the faculty in 1993. Dr. Edison returned to the University of Missouri in 2001 after a two-year leave of absence in Washington D.C., where she served on the Majority Health Staff of the Health, Education, Labor & Pensions (HELP) Committee of the United States Senate. She originally joined the Committee as a 1999-2000 Robert Wood Johnson Health Policy Fellow and stayed for an extra year as Health Policy Advisor to Senator James M. Jeffords of Vermont, who was then Chairman of the Committee. Dr. Edison was instrumental in the expansion of Medicare reimbursement for telemedicine in the 106th Congress. She was a key member of the legislative team that drafted the reauthorization of the Consolidated Health Center Programs, National Health Service Corps, and Community Access Program. She spent two years as key staff in a bipartisan coalition that developed the "Patient Safety Improvement Act of 2001," which serves as the foundation for current legislative proposals on patient safety.

### **David G. Ellis**

David G. Ellis, MD, FACEP - Dr. Ellis is an academic Emergency Medicine attending physician at the Erie County Medical Center (ECMC) in Buffalo, NY, where he serves as Associate Director, Emergency Services. He is an Assistant Professor of Clinical Emergency Medicine at the State University of New York (SUNY) at Buffalo, School of Medicine, and Director of the Telemedicine programs at ECMC and the SUNY Buffalo Dept. of Emergency Medicine. He has been practicing emergency

telemedicine since 1993, beginning with the Erie County Holding Center in Buffalo, the New York State Dept. of Corrections, and the Salamanca Healthcare Complex, a rural primary care hospital in the southern tier of western New York. He currently directs emergency triage systems at 51 facilities for the NYSDOCS as well as Erie County and Federal facilities across New York State. Dr. Ellis is also involved with trauma/critical care telemedicine systems and networks in western New York rural hospitals and a telemedicine task force for bioterrorism preparedness. Other research interests include outcome studies for emergency telemedicine, virtual palpation for remote examination, and mobile wireless roll-about telemedicine units for clinical applications.

### **Pamela Forducey**

Pamela G. Forducey received her PhD in Counseling Psychology from the University of Oklahoma in 1989. She has 14 years of urban and rural experience in the field of physical rehabilitation with special interest in working with individuals with acquired neurological injuries. Currently, she serves as the Director of Clinical Development for INTEGRIS Jim Thorpe Rehabilitation Hospital.

### **Sue Fox**

Sue Fox is the Project Director for EXTEND (Expanding Telehealth to North Idaho Districts), a grant funded program that provides telehealth services in rural Idaho. EXTEND's applications include telemental health, telepathology, telepharmacy, telerehabilitation, and an electronic medical record system. Sue is a board member on the Idaho Rural Health Association and actively participates in advocating telehealth services in Idaho. Trained as an epidemiologist, she was a Senior Research Coordinator for over 10 years in Chicago before relocating to Sandpoint, Idaho. Sue received her Masters in Public Health from the University of Illinois at Chicago in 1998.

### **Frank Gannan**

Mr. Gannan is the Telehealth Network Specialist for the Missouri Telehealth Network. He has been working in the area of telehealth since 1997. Mr. Gannan is a certified Videoconferencing Engineer. He manages the technical resources of the Missouri Telehealth Network which includes more than 60 videoconferencing systems and associated equipment. Mr. Gannan has a wealth of experience in various areas of the digital information field including software design and programming, network administration, and digital desktop publishing. He has also written a number of training manuals in these fields and he conducts training sessions for the Missouri Telehealth Resource Center.

### **Angela N. Haas**

Angela N. Haas, MD attended St. Joseph's University and Temple University School of Medicine in Philadelphia, PA. She graduated from Temple University School of Medicine in 1993, and attended The Williamsport Hospital and Medical Center

Family Practice Residency Program. She completed her residency in June 1996 where she was Chief Resident. While a resident in Williamsport, she received the prestigious Mead Johnson Award for excellence in leadership ability, community involvement, and exemplary patient care. Dr. Haas joined the faculty of The Williamsport Hospital and Medical Center Family Practice Residency Program in August of 1996. She completed a Faculty Development Fellowship at Duke University in the Spring of 2000. In November, 2002 she assumed the position of VP, Strategic and Business Development, responsible for physician recruitment and retention and strategic medical staff initiatives. Dr. Haas has been the Medical Director of Information Technology Department since June 2000. As medical director, she is a liaison between the medical staff and IT department in regard to all clinical systems at Susquehanna Health System. Dr Haas has spoken at HIMSS on issues regarding training physicians in medical informatics. Most recently, Dr. Haas, spoke at the American Medical Association's Quality Improvement Forum on Electronic Medical Records and her experience with using the Electronic Medical Record to improve the quality of care in the outpatient setting. Dr. Haas maintains a private practice at Loyalsock Family Practice in Williamsport, PA where she provides medical care to patients of all ages, from obstetrics to patients residing in nursing homes.

### **Beth Hudnall Stamm**

B. Hudnall Stamm, Ph.D., educated in psychology and statistics at Appalachian State University (BS, MA) and University of Wyoming (Ph.D.), is a Research Professor, Director of Telehealth, Director of the National Child Traumatic Stress Network Center for Rural, Frontier, and Tribal Health, and Director of the Idaho State University Institute of Rural Health. Stamm has held appointments at the VA National Center for Posttraumatic Stress Disorder, Dartmouth Medical School Department of Psychiatry, and University of Alaska Anchorage Department of Psychology and is a fellow of the American Psychological Association. Working primarily with rural underserved people, Stamm's efforts focuses on health policy, cultural trauma, and secondary traumatic stress among health care providers where telehealth figures prominently. Stamm pioneered teaching of technology and telehealth to psychology undergraduate and graduate students and has served on multiple national technology implementation committees. The author of over 100 professional publications, Stamm's work is used in over 30 countries and diverse fields including health care, bioterrorism and disaster responding, news media, and the military.

### **Jana Katz**

Jana Katz has been working with the UC Davis Health System since August of 1995, where she serves as the Chief Administrative Officer for the Center for Health and Technology (CHT). The CHT oversees programs designed to enhance health care through the use of advanced telecommunications and information technology. At UC Davis, the CHT includes video-based telemedicine, remote monitoring, distance

education, medical informatics, and operates the Telemedicine Learning Center. The Center for Health and Technology has received numerous awards, including being ranked as a Top Ten program in the country four times by Telehealth Magazine.

Prior to her role at UC Davis, Ms. Katz was with Stanford Health System where she began with the Cardiovascular Service Line and later became the Project Manager for the Stanford Telemedicine Program. Ms. Katz is a nationally recognized speaker on telemedicine and has provided expert testimony to the California State Legislature during their deliberations regarding Senate Bills 1665 and 2098. She is also a Board Member of the Center for Telehealth Law.

After completing her undergraduate degree in Genetics from the University of California at Davis, Ms. Katz received a Master degree in Public Health with an emphasis in Health Policy and Administration from the University of California at Berkeley. Her graduate studies also included work with the Institute of Medicine in Washington, D.C.

### **Elizabeth Krupinski**

Dr. Krupinski received her BA from Cornell University in 1984 and her PhD in Experimental Psychology from Temple University in 1992. She completed her early training at the University of Pennsylvania in the Department of Radiology. She is currently a Research Professor in the Departments of Radiology and Psychology at the University of Arizona and has been the Director of Evaluation & Assessment for the Arizona Telemedicine Program since 1997. Her main interests are in medical image perception, diagnostic decision-making strategies, human factors/ergonomics in the medical environment, and observer performance issues in radiology and telemedicine. A number of her studies have used eye-tracking technology to study the ways that clinicians interact with digitally displayed information. She is currently President of The Medical Image Perception Society.

### **Donal Lauderdale**

Donal Lauderdale, MSE, serves as Information Dissemination and Utilization Manager for the research programs at National Rehabilitation Hospital (NRH) in Washington, DC. Her work focuses on translating the outcomes of research, both tangible and intangible, into practice. Ms. Lauderdale has over 20 years experience in health care systems, and for the past 5 years has focused on the development of methods for delivering health services from a distance. She managed the Rehabilitation Engineering Research Center on Telerehabilitation at NRH and the Home Care and Telerehabilitation Technology Center at Catholic University. She sits on the Joint Research, Telehealth and Information Systems Steering Committees at National Rehabilitation Hospital and has been an independent expert reviewer for the Office for the Advancement of Telehealth (OAT), HRSA, for both its Congressionally-mandated telehealth projects and its Telehealth Network Grant

Program. Ms. Lauderdale served two terms as Rehabilitation Engineering and Assistive Technology Society of North America (RESNA) Telerehabilitation SIG chair and has presented on Telerehabilitation as part of a NIDRR panel and before such organizations as the American Congress of Rehabilitation Medicine.

### **Norman Levine**

Norman Levine is Professor of Medicine in the Section of Dermatology at the University of Arizona, and was the Chief of Dermatology at that institution for 17 years before stepping down in 2003. He is a graduate of the University of Michigan Medical School. He did his dermatology specialty training and research fellowship at the Albert Einstein School of Medicine in New York.

### **Margie Lockyear**

Margie has worked as a manager and project lead for over 20 years in the field of healthcare focusing on high visibility and complex IT projects. She was recently responsible for the project that converted all INHS TeleHealth sites to video over IP. This project also allowed the addition of 32 sites, implementing TeleHealth in hospitals, physician offices, clinics, Department of Corrections, Department of Health, Indian Health Clinics, and special projects such as TeleTrauma and TelePharmacy.

### **Ana Maria Lopez**

Ana Maria Lopez, MD, MPH, FACP, is Associate Professor of Clinical Medicine and Pathology at the University of Arizona and has a faculty appointment in the Hispanic Center of Excellence and College of Public Health. Currently she serves as Medical Director of the Arizona Telemedicine Program. Dr. Lopez speaks at national conferences on telemedicine clinical practices. Dr. Lopez has a long-standing commitment to underserved populations and is dedicated to increasing access to high quality medical specialty care to all communities via the telemedicine network. Dr. Lopez is a professional educational and co-chair of the University of Arizona National Center of Excellence in Women's Health. Dr. Lopez has a strong research background in the field of health care inequities, and currently has several funded projects in this area. Dr. Lopez is currently funded to assess the special needs of long-term breast cancer survivors in urban Southeastern and along the Arizona US/Mexico border via in-person and videoconference focus groups.

### **Denny Lordan**

Denny Lordan is currently Senior Telehealth Consultant for Northwest TeleHealth, a collaborative program involving 53 Washington State hospitals, clinics, prisons and mental health centers. Denny has been in the computer field as a network analyst at Sacred Heart Medical Center in Spokane Washington and most recently for Inland Northwest Health Services for the past 20 years. A division of Inland Northwest Health Services, the telemedicine network works closely with Information Resource

Management to provide integrated data, internet, imaging and video-conferencing services to many of the same hospitals in eastern Washington.

### **Thelma McClosky Armstrong**

Ms. McClosky Armstrong has over 25 years of experience in the development and management of healthcare delivery services. As director of the Eastern Montana Telemedicine Network, Thelma is responsible for the overall management of a 20-site interactive videoconferencing network providing medical and mental health services, continuing medical and higher education, administrative and telebusiness services throughout eastern and central Montana and northern Wyoming. The Eastern Montana Telemedicine Network recently received the American Telemedicine Association's Presidents Award for the Advancement of Telemedicine. This award is given annually to a program for its outstanding and lasting contribution to the field of telemedicine. Ms. McClosky Armstrong is the Past-President of the Montana Healthcare Telecommunications Alliance (MHTA) and is a member of the Board of Directors of the American Telemedicine Association. For the past four years she has chaired the ATA policy committee and in April was elected Vice President of the ATA.

### **Bryan Nation**

Bryan Nation is a Telehealth Network Analyst for Banner Health in Colorado. He is part of the Information Technology Department and Outreach Department which supports telehealth in the Rocky Mountain Region. Mr. Nation was formerly with the High Plains Rural Health Network where he spent seven years researching, building and maintaining the telecommunications infrastructure for rural hospitals in Wyoming, Nebraska, Kansas and Colorado. He continues to maintain a part of the High Plains Rural Health Network today. Mr. Nation also works as a professional contract cameraman for Comcast/AT&T where he films high school and college sporting events. Bryan has also participated in technical meetings with the federal Office for the Advancement of Telehealth.

### **Hon S. Pak**

Hon Pak, MD, currently stationed at Brooke Army Medical Center, is the functional proponent for AMEDD's Teledermatology Program and is an internationally recognized leader in the field of teledermatology. He has conducted extensive research and published numerous articles and chapters on telemedicine and dermatology. Moreover, he has been an invited speaker at many national and international dermatology and telemedicine meetings. He has received several research awards and Venture capital funding to include the most recent three year \$2.2 Million to optimize dermatology services in GPRMC using teledermatology. He has been active in telemedicine since 1996 when he helped conceptualize and develop today's Army teledermatology program. Since then he has been active in TMA's Telehealth IPT, Army's Telehealth IPT, Readiness IPT and currently chairs the teledermatology W-IPT. MAJ Pak's contribution in developing the business model for teledermatology has had a significant impact to the field of telemedicine in

the military. He initially started his military career as a combat medic in 1983. He is a graduate of United States Military Academy and Uniformed Services University of Health Sciences. He has been stationed in Korea, Germany, Ft Hood, Ft Meade, and Brooke Army Medical Center. Until recently, he was the associate program director for the SAUSHEC Dermatology Residency Program. Dr. Pak is a member of the Board of Trustees of the Sulzberger Institute, Assistant Professor of Dermatology at USUHS and is the secretary and board of trustee of the telemedicine taskforce and a member of the ad-hoc Bioterrorism Taskforce for the American Academy of Dermatology. In addition, he is the Interim chairman for the Teledermatology special interest group for American Telemedicine Association (ATA). Recently he was recognized as a finalist of the ATA's President Award and selected for a Board of Director of the American Telemedicine Association.

### **Michael Patterson**

Michael Patterson has over 29 years experience in healthcare technology. Michael is experienced in electronics, information technology and radiological engineering and he has served as a radiological engineer and radiology technical director. Presently, he serves as technical manager for the Office of Telemedicine at the University of Virginia Health Sciences Center.

### **Lorraine Pellegrino**

Ms. Pellegrino, a registered nurse who holds a master's degree in health care administration has 27 years experience in the healthcare industry. As a nurse her background includes clinical bedside care within a wide range of clinical inpatient units. Additionally she has experience in management in hospital, clinic, and HMO settings. Ms. Pellegrino has been with the University of California, Davis Health System since 1991. In 1997, she joined the Center of Health & Technology serving as the Regional Nurse Liaison. Over the past seven years, she had developed telemedicine specialty referral guidelines for health care providers with specific emphasis on telehealth applications and distant educational programs for rural communities. She has worked at various locations in northern California to assist sites with the assessment and implementation of telehealth and its various applications. She also has served as project manager on various federal and state grants. Ms. Pellegrino has spoken across the country on home telehealth, placing special emphasis on training and education needs of all participants. She has also published various articles in the healthcare industry. She serves as Vice Chair of the American Telemedicine Association's Home Telehealth Special Interest Group.

### **Charles D. Peterson**

Charles D. Peterson is Dean and professor of pharmacy practice in the College of Pharmacy at North Dakota State University. He also serves as Principal Investigator and Project Director for the North Dakota Telepharmacy Project. He received both his B.S. and Pharm.D. degrees from the University of Minnesota in 1976 and 1977,

respectively. He completed a postdoctoral fellowship in Clinical Toxicology at Hennepin County Medical Center in Minneapolis in 1978.

Dr. Peterson's scholarly achievements include over 50 peer reviewed publications on a variety of topics including toxicology, curriculum innovations and development, and most recently telepharmacy. He has procured over \$8.0 million in grants and contracts as principal investigator from private, state, and federal funding agencies, the most recent of which is funding from the Office for the Advancement of Telehealth/HRSA to support the implementation of a state-wide telepharmacy program in North Dakota to restore and retain pharmacy services in medically underserved rural areas of state. Dr. Peterson also serves as a member of the evaluation team for the American Council on Pharmaceutical Education, the agency responsible for accrediting schools of pharmacy nationally.

### **Richard Phillips**

Rick Phillips is currently the Director of St. Claire TeleCare at St. Claire Regional Medical Center in Morehead, Kentucky. St. Claire TeleCare is a 29-site regional telemedicine hub that sees over 1500 patients per year. Rick, originally trained in the Biomedical engineering field during a tour in the United States Army, has worked with medical instrumentation for over 17 years. His involvement with Telemedicine began in 1994 with the inception of the St. Claire TeleCare program. His background and Associates Degree in Biomedical Engineering Technology has helped him design, build and support all aspects of the TeleCare network infrastructure.

Rick has served on several local, regional and national committees relating to Telemedicine Technology. He has presented on telemedicine, telemedicine technology and specific telemedicine applications to local, regional and national organizations as well. He currently serves as the Director of the Eastern Kentucky TeleHealth Training Center as well as Chairman of the Infrastructure and Network Operations Committee for the Kentucky TeleHealth Network.

### **Micha Post**

Micha Leah Post served as the Telemedicine Project Coordinator and Operations Assistant for the Rural Telemedicine Project at INTEGRIS for six years. She was active in testing, installation and providing technology support. She played a key role in problem solving related to field applications of the technology and helped address key human factor issues related to the project.

### **Karen Rheuban**

Karen S. Rheuban, M.D. currently serves as Professor of Pediatrics, Senior Associate Dean for External Affairs and Continuing Medical Education and Medical Director of the University of Virginia Office of Telemedicine. As a pediatric cardiologist, Dr. Rheuban provides direct clinical services to patients with congenital and acquired heart disease. Dr. Rheuban is a fellow of the American College of



Cardiology and the American Academy of Pediatrics. She is listed in the “Best Doctors in America” database, and was recently recognized to be profiled in the National Library of Medicine’s exhibit “Changing the Face of Medicine”.

As Associate Dean, Dr. Rheuban oversees the University’s large Office of Continuing Medical Education. That office develops and sponsors thousands of hours of continuing medical education per year using multiple formats, such as lectures, conferences, a 26 facility affiliated hospital program and through computer-assisted instructional materials and web-based on-line offerings.

Dr. Rheuban has been awarded grants and contracts totaling more than a million dollars from the federal government, the Commonwealth of Virginia, corporations and foundations to support telehealth. She serves as a board member of the American Telemedicine Association and is a board member of the Center for Telemedicine Law.

### **Michael A. Ricci, MD**

Dr. Ricci is Roger H. Allbee Professor of Surgery, Clinical Director of Telemedicine and Vice Chair of Surgical Research at Fletcher Allen Health Care and the University of Vermont, and Associate Dean of Continuing Medical Education at the University of Vermont College of Medicine. Dr. Ricci has been instrumental in the implementation of the Telemedicine Program that has twice been named one of the Top Ten in the Nation while maintaining a full time practice in clinical vascular surgery. He maintains a basic science lab in vascular surgery but has also done research on the utilization and efficacy of Fletcher Allen’s telemedicine system. Dr. Ricci is the author of 100+ peer-reviewed publications and 8 book chapters on topics in telemedicine and vascular surgery. Dr. Ricci obtained a BA degree from Hamilton College and his MD from the SUNY Upstate Medical Center in Syracuse, NY. He then trained in General Surgery at the Guthrie Clinic in Sayre, PA and obtained vascular fellowship training from McGill University in Montreal.

### **Cynthia Scheideman-Miller**

Cynthia Scheideman-Miller MHA, received her Masters of Health Care Administration degree in 1995 from the University of Kansas. She has served as Director of the Rural Telemedicine project at INTEGRIS since 1998. In this position, she has provided leadership in the development, implementation, promotion and evaluation of telemedicine and related grants within INTEGRIS and among partners. She serves as an expert resource for telehealth and takes a special interest in legislation and licensure related to telehealth. She has produced numerous articles and presentations for telehealth promotion and education.

### **Richard Settimo**

Richard Settimo has been with the Office of Telemedicine since retiring from the US Army in 1994. His primary function is to manage the Department of Corrections Telemedicine contract. He is also responsible for all grant related activities, finance,

personnel and equipment purchases. A graduate of Murray State University, with a BA and an MA and the Army War College, Carlisle Barracks, PA.

### **Russell C. Spearman**

Russell C. Spearman is the Project Director for Idaho's Traumatic Brain Injury implementation grant from the Health Resources Services Administration, Maternal and Children's Health Bureau. Russ is employed by the Institute of Rural Health at Idaho State University. Prior to this Russ was responsible for developing and implementing all aspects related to Idaho's 1915 C Medicaid Home and Community Based Services Waiver for adults with a traumatic brain injury through the Idaho Department of Health and Welfare. He is the former Executive Director for Idaho's Governor's Council on Developmental Disabilities. He is the author of "The Use of Medicaid Waivers and Their Impact on Services" and "Journey to Success: Discovering Vocational Opportunities for Idahoans with Disabilities". Russ was instrumental in developing Idaho's Home of Your Own Initiative that continues today and has assisted over sixty people with disabilities realize their dream of home ownership. Over the years he has personally and in collaboration with others assisted in the passage of several pieces of legislation on behalf of Idahoans with disabilities.

### **Ryan Spaulding**

Ryan J. Spaulding, PhD, is the Director of the Center for Telemedicine & Telehealth at the Kansas University Medical Center in Kansas City. In this role, he administers all telehealth projects, research activities and daily operations of the department. Dr. Spaulding's research interests include diffusion of innovation as applied to health information technologies, and the economic implications of telemedicine, telehealth and health informatics services. He earned his BS and MA degrees from Central Michigan University, and his PhD from the University of Kansas.

### **Rob Sprang**

Rob has been the Director of Kentucky TeleCare, the telehealth program based at the University of Kentucky Chandler Medical Center since September, 1996, and also oversees the Kentucky TeleHealth Network, the statewide telehealth program mandated by legislation that passed during the 2000 KY legislative session. Rob also developed the PROACT (Preparedness and Response On Advanced Communications Technology) videoconference network that will allow interactive videoconference connectivity between 20 Kentucky healthcare facilities, the Kentucky Department of Public Health and the CDC 24 hours/day, 7 days/week in the event of a disaster. The PROACT network has been used to train hundreds of healthcare professionals on disaster preparedness and response.

Rob received a Master's degree from the University of Texas at Arlington with a concentration in Information System's Management in 1993. Rob is also a Board Member of the Center for Telemedicine Law.

### **Deborah Swirczynski**

Deborah L. Swirczynski, MA, is the TeleKidcare® Project Manager for the Center for Telemedicine and Telehealth. Collaborating with community advocates, school professional and health care providers, Deborah promotes the role of the school nurse and the importance of a synergetic, coordinated effort to ensure that children's health care needs are met. Deborah earned her BA in Communications from Washburn University and MA in Communication Studies from the University of Kansas.

### **Joseph A. Tracy**

Joseph Tracy, MS, is the Executive Director of Telehealth for the University of Missouri and the Missouri Telehealth Network (MTN). Since 1994 he has directed the operations of the MTN and worked actively on public and private policy issues related to telehealth. He drafted the telehealth Medicare reimbursement language for the Southern Governors Association in 1999 and U.S. Senate Bill 2505. In 2003, the MTN was awarded the ATA President's Award in recognition of its contributions in the development of telemedicine and its advancement worldwide.

Mr. Tracy received his MS in Applied Psychology from Stevens Institute of Technology in New Jersey. He is currently Chairman of the Board for the Center for Telemedicine Law in Washington, D.C. and is Vice Chair of the American Telemedicine Association's (ATA) Policy Committee.

### **Wanda Weekly**

Wanda Kjar Weekley RN, BS graduated with a diploma in nursing and has a Bachelor of Science degree in health care management. Ms. Weekley worked as Director of Nursing in a 40 bed hospital in Lexington Nebraska for 17 years before working as a house manager at Good Samaritan Hospital in Kearney Nebraska in 1994-1996. She was the Telemedicine Nurse Coordinator for Good Samaritan Hospital's Mid-Nebraska Telemedicine Network in May of 1996 before becoming the Director of Telemedicine in 1998.

### **Nancy Willis**

Nancy R. Willis is Vice President of Marketing and Development for St. Alexius Medical Center in Bismarck, ND. In her role, Willis oversees Telehealth and Outreach Services for the medical center. Willis has worked in healthcare communications for 17 years and during that time has served as a lobbyist for the North Dakota Healthcare Association (the state hospital association), advocating for Telehealth issues and writing legislation dealing with this and other healthcare issues. Willis served for two years on the ND Governor's Telemedicine Task Force, helped draft the state Critical Access Hospital legislation and currently serves on the Robert Wood Johnson "Covering Kids and Families" SCHIP advisory board. In her

role overseeing the St. Alexius Medical Center TeleCare Network, Willis successfully lobbied ND Medicaid and ND Blue Cross Blue Shield to cover Speech Therapy services over telemedicine and continues to advocate for Medicare coverage, as well as Congress to make nursing homes a reimbursable site of service. The TeleCare Network has been in place since 1995. The network is composed of 22 sites including clinics, hospitals and nursing homes and has been an OAT grantee since 1997.

### **Pamela R. Wirth**

Pamela R. Wirth, FHIMSS.CPHIMSS is the Vice President/Chief Information Officer of Susquehanna Health System, Williamsport, PA. She has responsibility for Information Technology, Telecommunications, Health Records, HIPAA and the Medical Library. Pamela also serves as the CIO for both the Laurel Health System and the Jersey Shore Hospital who have outsourced MIS contracts with the Susquehanna Health System.

Her twenty-one year career has been dedicated to healthcare information system management. Before joining The Williamsport Hospital & Medical Center in 1986 as the Administrative Director of MIS, she served for six years as the Director of Data Processing at Muncy Valley Hospital, Muncy, PA. She begins her term as chair of HIMSS (Healthcare Information Management Systems Society) board of directors for 2004/2005 on July 1, 2004. She is a fellow in HIMSS, has achieved CPHIMSS status and is a member of American College of Healthcare Executives, College of Healthcare Information Executives, and the American Medical Informatics Association.

Pamela has received the Hospital Association of Pennsylvania's President Achievement Award in 1996. She was instrumental in Susquehanna Health System being named to the Top 100 Most Wired Institutions for the past 5 years. She serves as the principal investigator in three federal grants for the advancement of electronic medical records. Pamela has presented at the 1998, 2001, and 2004 national HIMSS conferences, has been a participants in three Healthcare Leaders forums, and served as the keynote speaker at the 2001 Soft Med Annual User Conference. She has served as a host for Siemens Medical Inc. National Showcase Account for the past 7 years, showing Susquehanna Health System IT systems on a weekly basis to visiting organizations world-wide.

### **Brian Wispelwey**

Brian Wispelwey, MD, currently serves as a Professor of Internal Medicine in the Division of Infectious Diseases at the University of Virginia Medical Center. He received his Medical degree at the University of Medicine and Dentistry of New Jersey, New Jersey Medical School. He did his residency in Internal Medical at Harvard university (New England Deaconess Hospital) and received a fellowship to the University of Virginia (Infectious Diseases). His primary clinical interests are AIDS, Immunocompromised Host and CNS Infections.

Dr Wispelwey is a pioneer in the treatment of HIV/AIDS patients using Telemedicine technology. His work with the Virginia Department of Corrections (DOC) helped develop the Telemedicine protocols for the UVA/DOC Telemedicine program treating HIV/AIDS. Dr Wispelwey is also a leading educator on the subject of HIV/AIDS. He has traveled to South Africa to evaluate and help develop that country's HIV/AIDS education program. He is in constant demand throughout the state, giving presentations on the subject of Infectious Diseases.