

February 2015  
Online Print Version

# International Journal of Scientific and Research Publications

Print Version, Volume 5, Issue 2  
**February 2015 Edition**  
ISSN 2250-3153



**IJSRP**  
[www.ijsrp.org](http://www.ijsrp.org)

# International Journal of Scientific and Research Publications

## GENERAL INFORMATION:

IJSRP, International Journal of Scientific and Research Publications publish monthly journal under ISSN 2250-3153.

## ONLINE VERSION

<http://www.ijsrp.org/e-journal.html>

## PRINT VERSION

<http://www.ijsrp.org/print-journal.html>

All the respective authors are the sole owner and responsible of published research and research papers are published after full consent of respective author or co-author(s).

For any discussion on research subject or research matter, the reader should directly contact to undersigned authors.

## COPYRIGHT

Copyright©2015 IJSRP.ORG

All Rights Reserved. No part of this publication may be reproduced, stored in a retrieval system, or transmitted, in any form or by any means, electronic, mechanical, photocopying, recording, scanning or otherwise, except as described below, without the permission in writing of the Publisher.

Copying of articles is not permitted except for personal and internal use, to the extent permitted by national copyright law, or under the terms of a license issued by the national Reproduction Rights Organization.

All the published research can be referenced by readers/scholars/researchers in their further research with proper citation given to original authors.

## DISCLAIMER

Statements and opinions expressed in the published papers are those of the individual contributors and not the statements and opinion of IJSRP. We assume no responsibility or liability for any damage or injury to persons or property arising out of the use of any materials, instructions, methods or ideas contained herein. We expressly disclaim any implied warranties of merchantability or fitness for a particular purpose. If expert assistance is required, the services of a competent professional person should be sought.

## Contact Information:

Editor: [editor@ijsrp.org](mailto:editor@ijsrp.org)

Website: <http://www.ijsrp.org>

## Table of Contents

Differential pulse polarographic method development and validation of riboflavin in pharmaceutical formulation.....	8
<b>L.M.Kashid*</b> , <b>S.V.Patil**</b> .....	8
Perinatal outcome in antepartum hemorrhage in teaching hospital of northern India- A prospective study.....	13
<b>Shaveta Jain*</b> , <b>Nitin Jain**</b> , <b>Pushpa Dahiya*</b> , <b>Seema Rohilla**</b> , <b>Roopa Malik*</b> .....	13
Amitriptyline Effect on Tumor Necrosis Factor- $\alpha$ , Interleukin-1 and Interleukin-6 Serum Level and its Correlation with Pain Severity in Chronic Tension-Type Headache Patients .....	19
<b>Aldy S. Rambe*</b> , <b>Hasan Sjahrir*</b> , <b>Moh. Hasan Machfoed**</b> .....	19
Hybrid bifunctional nanostructures as stimuli-responsive.....	23
<b>Darsana.M.D</b> .....	23
Marketing films through Social Realities: Shyam Benegal's 'Welcome to Sajjanpur'- A Case Study .....	31
<b>Ms. Suparna Naresh and Dr.Jagadeesh Prakash</b> .....	31
Navigation system for an autonomous robot using fuzzy logic.....	39
<b>Vivek Yerubandi*</b> , <b>Y. Mukunda Reddy**</b> , <b>M. Vinod Kumar**</b> .....	39
Assessment of the nutritional values of Dried Bread Fruit Peel Meal (DBPM) as a replacement for Maize in the Formulated Diet of Giant Africa Land Snail <i>Archachatina marginata (swainson)</i> .....	43
<b>Ogunkunle Tajudeen</b> .....	43
System development of mechanism, anchoring devices in pre and post Tensioned concrete structural elements. ....	48
<b>Pradeep Nath Mathur*</b> , <b>Prof.(Dr.) A. K. Sinha**</b> .....	48
The Association between Genetic Variation of Interferon Gamma +874 T/A and Plasma Interferon Gamma Level in Pulmonary Tuberculosis .....	53
<b>Erwin Arief*</b> , <b>Muh. Nasrum Massi**</b> , <b>Irawaty Djaharuddin*</b> , <b>Budu Mannulusi**</b> , <b>Eliana Muis***</b> , <b>Suwarti Rantono***</b> .....	53
Carcinoembryonic antigen, C-reactive protein and albumin as prognostic indicators in colorectal carcinomas .	58
<b>Dr. Rajesh Nair, MS, Senior Resident*</b> , <b>Dr. Bhavna Nayal, MD, Assistant Professor**</b> , <b>B H Anand Rao, Professor, Department of Surgery***</b> .....	58
Three Phase Load Balancing and Harmonic Reduction using Distribution Static Compensator.....	68
<b>Raghvendra Singh*</b> , <b>Dharmendra Singh**</b> .....	68
Evaluation of Post Chemotherapy Bone Marrow Changes in Acute Leukaemia.....	72
<b>Sushma Belurkar, Pankaj Bahadur Nepali, Bhawani Manandhar, Chetan Manohar</b> .....	72
Review on Optical Mimo System.....	79
<b>Mridu Jain*</b> , <b>Ritu Dubey**</b> , <b>Vishal Pasi***</b> .....	79
The Economic and Socio-Cultural Balance Sheet of Tourism in Goa: Future Options .....	84
<b>Dr. Savio P. Falleiro</b> .....	84
A Rare Case Report of Guillian Barre Syndrome Presenting with Unilateal Facial Nerve Palsy.....	91
<b>Dr. B. Suryanarayana*</b> , <b>Dr. R. Siddeswari**</b> , <b>Dr. B. Sudarsi***</b> , <b>Dr. S. Manohar****</b> , <b>Dr. Pramod*****</b> .....	91
Studies on Primary Productivity of Bay of Bengal at Chandrabhaga Sea-Shore, Konark , Odisha.....	94
<b>Ashabari Sahoo and A.K.Patra</b> .....	94
Response of Pechay ( <i>Brassica napus</i> L.) to Different Levels of Compost Fertilizer.....	98
<b>Leif Marvin R. Gonzales*</b> , <b>Ramonita A. Caralde**</b> and <b>Maita L. Aban***</b> .....	98
Spectral studies on transition metal complexes with novel tridentate aroylhydrazones.....	102
<b>Kamalika Banerjee*</b> , <b>Pramod Kumar Singh**</b> , <b>Sangeeta Singla***</b> .....	102

Approach of Crashing Critical Activity (CCA) and Stretching Non-critical Activities (SNA) of Time Cost Trade off problems using Critical Path Method.....	107
<b>Dr.P.Hima Bindu</b> .....	107
Evaluation of Tensile and Interfacial Strength of Coconut Palm Leaf Midrib as a potential Reinforcement for Plastics .....	116
<b>Neeraj Dubey*, Geeta Agnihotri*</b> .....	116
Perceived Factors Affect Female Undergraduates' Attitudes toward Entrepreneurship Development ..... (Comparison Public and Private Universities in Ethiopia).....	123
<b>Chalchissa Amentie*, Abdissa Gurmessa**, Emmet Negash*</b> .....	123
Duties Family in The Prevention of Acute Respiratory Infectious Disease (ARI) in Children in Society based on Leinenger Theory Approach.....	134
<b>Nuzul Qur'aniati, S.Kep., Ns., M.Ng, Iqlima Dwi K, S.Kep., Ns., M.Kep, Aria Aulia N, S.Kep., Ns., M.Kep</b> .....	134
Understand our student's idiomatic phrase? .....	138
<b>Valentina Ilieva, PhD</b> .....	138
HIV/Aids-Tuberculosis (Pulmonary and Extra Pulmonary) Co- Infection: Sputum Positivity and Cd4 Correlation .....	143
<b>Dr. R. Siddeswari*, Dr. B. Sudarsi**, Dr. Sanjeev***, Dr. B. Suryanarayana****, Dr. S. Manohar*****, Dr. Abhilash*****</b> .....	143
Serum MDA (Malondialdehyde),hs-CRP and Adenosine Deaminase Levels in Pulmonary Tuberculosis Patient's.....	147
<b>EswarReddy Kandukuri*, D.V.H.S.Sarma**, P.Sushma***, D.Moulali****, Asiya naaz*****</b> .....	147
Neem based formulations used against bud fly, <i>Dasyneura lini</i> Barnes in Linseed ( <i>Linum usitatissimum</i> ) crop .....	150
<b>S. DEOLE<sup>a1*</sup> GUPTA, A. K.<sup>a2</sup>, D. DASH<sup>b</sup></b> .....	150
Audience Perception of the Credibility of Local News Channels .....	154
<b>Mr. H.Naresh Rao and Dr. B.K Ravi</b> .....	154
Some neglected and underutilized fruit -crops in Sri Lanka.....	165
<b>Nilanthi Dahanayake</b> .....	165
Central Pontinemyelinolysis: Report of a Rare Case with a Good Outcome. ....	172
<b>Dr. D. Sridhar*, Dr. G. Balaraju**, Dr. R. Siddeswari***, Dr. B. Sudarsi****</b> .....	172
Utilization of Maternal Health Care Services in a Rural Community of Eastern Nepal .....	175
<b>Dr Sanjay Kumar*, Prof K. C. Premarajan**, Prof S. Nagesh***, Prof Nilamber Jha****</b> .....	175
Effects of Phosphorus and Zinc on the Growth and Yield of Mungbean (BARI mug 6).....	178
<b>M. M. Rahman<sup>1</sup>, M. J. Adan<sup>2</sup>, M. S. N. Chowdhury<sup>3</sup>, M. S. Ali<sup>1</sup> and S. T. Mahabub<sup>4</sup></b> .....	178
Interaction Effect of Phosphorus and Zinc on the Concentrations of N, P, K, S and Zn in Mungbean Stover and Seed.....	182
<b>A. Barman<sup>1</sup>, M. J. Chowdhury<sup>2</sup>, S. T. Mahabub<sup>3</sup>, M. Quamruzzaman<sup>2</sup> and A. Mondul<sup>2</sup></b> .....	182
The Implementation of Recovery: A Literature Review .....	185
<b>Mundakir*</b> .....	185
Climate Change and Rice Yield in Bangladesh: A Micro Regional Analysis of Time Series Data.....	189
<b>A. H. M. Monzurul Mamun*, Bikash Chandra Ghosh**, S.M. Rayhanul Islam***</b> .....	189
Better Life: Perceptions of Happiness in the Capital of Latin America .....	197
<b>Patricia Iturriaga, B.S., Toni DiDona, Ph.D</b> .....	197
Mycoplasma Pneumoniae infection complicated by multiorgan dysfunction Syndrome (MODS), with a favorable recovery .....	204
<b>Dr. Abdul Wahid Bhat*, Dr. Bader Alhomayeed**, Dr. Adil Manzoor***, Dr. Khalid Al-Wadei****, Dr. Ahmed Imtiyaz*****</b> .....	204



ARE READY-MADE TECHNOLOGY TRANSFER SOLUTIONS SUITABLE FOR DEVELOPING THE RENEWABLE ENERGY SECTOR IN SRI LANKA? .....	210
<b>WITHANAARACHCHI, A.S, NANAYAKKARA, L.D.J.F, PUSHPAKUMARA, C.</b> .....	210
REVIEW ON MINIMIZING DISTORTION AND IMPROVING QUALITY OF VIDEO IN MULTI CLIENTS NETWORK.....	218
<b>MISS. AMREEN M. KHAN, PROF. RANJANA S. SHENDE</b> .....	218
Comparative efficiency of five potash and phosphate solubilizing bacteria and their key enzymes useful for enhancing and improvement of soil fertility.....	222
<b>Sajidmohammad A Saiyad<sup>*</sup>, Dr. Yogeshvari K Jhala<sup>**</sup>, Dr. R. V. Vyas<sup>**</sup></b> .....	222
A comprehensive comparison of SQL and MongoDB databases.....	228
<b>Rajat Aghi, Sumeet Mehta, Rahul Chauhan, Siddhant Chaudhary and Navdeep Bohra</b> .....	228
Induction of apoptosis by a potent Betulinic acid derivative in Human colon carcinoma HT-29 cells .....	231
<b>Debasmita Dutta<sup>*</sup>, Ankita Sarkar<sup>*</sup>, Biswajit Chakraborty<sup>**</sup>, Chinmay Chowdhury<sup>**</sup>, Padma Das<sup>*</sup></b> .....	231
Recycling of industrial waste and its impact on the environmental quality costs .....	239
<b>Dr. Nasreldeen Gidam Elnagy</b> .....	239
Absorption Studies of Creatinine using End-Point Method by Optical Interference Wavelength Filter .....	247
<b>Sreedhar Malleti<sup>*</sup>, Dr.Bhujangarao A<sup>**</sup>, Dr.Varaprasad PLH<sup>**</sup></b> .....	247
DESIGN OF HIGH SPEED AND LOW POWER 4T SRAM CELL.....	251
<i>P. Pavan Kumar<sup>1</sup>, Dr. R Ramana Reddy<sup>2</sup>, M.Lakshmi Prasanna Rani<sup>3</sup></i> .....	251
An Analytical Study of Dissimilar Materials Joint Using Friction Welding and It's Application.....	256
<b>Sirajuddin Elyas Khany<sup>1</sup>, S.N.Mehdi<sup>2</sup> G.M.Sayeed Ahmed<sup>3</sup></b> .....	256
Gripper Actuator Using Shape Memory Alloy Spring .....	260
<b>Sundara sathiyam KS, Vikram singh I, Rajesh V</b> .....	260
Stock Price Volatility and Dividend Policy in Pakistan .....	262
<b>Muhammad Abrar-ul-haq<sup>*</sup>, Kashif Akram<sup>**</sup>, Muhammad Imdad Ullah<sup>**</sup></b> .....	262
Micro-level Determinants of Rural Poverty in Pakistan.....	269
<b>Muhammad Abrar ul haq<sup>*</sup>, Kashif Ayub<sup>**</sup>, Muhammad Imdad Ullah<sup>***</sup></b> .....	269
The Influence of Individual Characteristics on Organization Performance and Job Satisfaction .....	273
<b>Asad-ur-Rehman<sup>*</sup>, Muhammad Imdad Ullah<sup>**</sup>, Muhammad Abrar-ul-haq<sup>**</sup></b> .....	273
“The Mayor of Casterbridge”: Attitude toward Changes and Challenges of Social Conventions. ....	278
<b>Tazir Hussain</b> .....	278
DIGITAL ATTENDANCE CALCULATION SYSTEM USING SUPPORT VECTOR MACHINE & IMAGE PROCESSING.....	281
<b>RAJIB BAG, GAUTAM, KOMAL DAS, P. MOHINI AMMA</b> .....	281
Closed loop traffic signal controller .....	290
<b>Reshmi Banerjee</b> .....	290
Age-related macular degeneration: Prevalence and Risk factors in elderly population (aged >60 years) in Central India.....	296
<b>Dr. RP Singare<sup>*</sup> Deshmukh S, Ughade SN<sup>**</sup>, Thakre SB<sup>**</sup></b> .....	296
Integrating Risk Reduction Strategies for a Sustainable Disaster Management in Nigeria .....	302
<b>Arc. Abubakar Sarkile Kawuwa<sup>*</sup>, Sani Jauro Adamu<sup>**</sup>, Abdullahi Taofik Umar<sup>***</sup></b> .....	302
Effect of Different Types of Organic Manure and Mulching on the Growth and Yield of Carrot (Daucus Carota L.).....	309
<b>H. E. M. Khairul Mazed<sup>1</sup>, Md. Ashrafur Islam Pulok<sup>2</sup>, Md. Shah Newaz Chowdhury<sup>3</sup>, Jannatul Ferdous Moonmoon<sup>4</sup> and Nur-unnahar<sup>5</sup></b> .....	309
Comparison of the use of single lung ventilation Vs both lung ventilation in Video Assisted thoracoscopy ....	315
<b>MVG Pinto<sup>1</sup>, KB Galketiya<sup>2</sup></b> .....	315
Austrian German in Teaching the German Language .....	319
<b>Valentina Ilieva</b> .....	319
Read/Write Stability Improvement of 8T Sram Cell Using Schmitt Trigger .....	325
<b>Dr. A. Senthil Kumar<sup>*</sup>, I.Manju<sup>**</sup>, S.Sumathi<sup>**</sup>, C.Preethi<sup>***</sup></b> .....	325

Impact of balanced fertilization and legume mixture on fodder oat ( <i>Avena sativa L.</i> ) .....	331
<b>Arjun Kumar Verma* and K. L. Jeengar**</b> .....	331
Importance of Vegetation in Urban Environment .....	336
<b>Prof. Borse Nitin Bajirao</b> .....	336
Persistence of Farmer-Herder Conflicts in Tanzania.....	339
<b>Davis Mwamfupe</b> .....	339
Effect of Carbon Nanotube on Thermo-Mechanical Properties of Glass Fiber/Epoxy Laminated Nanocomposites.....	347
<b>Shubham Gupta<sup>1</sup>*and Ariful Rahaman<sup>1</sup></b> .....	347
Study of Deep Drawing Process Parameters: A Review .....	352
<b>Chandra Pal Singh*, Geeta Agnihotri**</b> .....	352
THE WVSU-Lambunao Campus College Freshmen: Who, What, and Why .....	367
<b>Nelson G. Laru-an*, Dominador L. Lisao**</b> .....	367
Level of Effectiveness of Community Policing.....	370
<b>Nelson G. Laru-an, Harrah T. Beup</b> .....	370
Effect of Moringa Oleifera Leaf Extracts Supplementation in Preventing Maternal Anemia and Low-Birth- Weight.....	376
<b>Ishaq Iskandar<sup>1</sup>, Veni Hadju<sup>2</sup>, Suryani As'ad<sup>3</sup>, Rosdiana Natsir<sup>4</sup></b> .....	376
Prevalence and seasonal occurrence of gastrointestinal parasites in small ruminants of coastal areas of TamilNadu. ....	379
<b>A. Varadharajan and R. Vijayalakshmi</b> .....	379
A Newborn with Epidermolysis Bullosa .....	384
<b>R.Prasanna, S.Subash</b> .....	384
Unusual Foreign Body in the Mastoid.....	387
<b>Dr. P. K. Purushothaman, Dr. C.R.K. Balaji, Dr Sonia Sera Thomas</b> .....	387
Unit Rectangle Visibility Representation of Binary and Ternary Tree .....	389
<b>Mehnuma Tabassum Omar, Kamrun Naher, Monika Gope and Ummay Asma</b> .....	389
Application of Information Computer-based Learning in Calculus Package Learning .....	394
<b>Mathilda Lasut*</b> .....	394
Photon Induced Electron Transfer in Quantum Dot Solar Cell .....	398
<b>Ubani Charles Ahamefula</b> .....	398
Preparation and Characterization of CdSe QDs via Pyrolysis of Organometalic Reagent.....	408
<b>Ubani Charles Ahamefula</b> .....	408
Epidemiological and Microbiological Profile of Infectious Corneal Ulcers in Tertiary Care Centre, Kumaon Region, Uttarakhand .....	415
<b>Dr Laltanpuia Chhangte, * Dr Shanti Pandey, * Dr Umesh**</b> .....	415
Future Wireless Technology.....	420
<b>Sneha Dixit</b> .....	420
Film Bulk Acoustic Wave (FBAR) Resonator .....	424
<b>Sneha Dixit</b> .....	424
Anti-Inflammatory Activity of Chrysin in Acute and Chronic Phases of Inflammation in Guinea Pigs .....	427
<b>Warda Mohamed Kaidama and Rajesh N. Gacche</b> .....	427
FILTERING EFFECT IN HOLOGRAPHIC IMAGE PROCESSING.....	432
<b>Ferdous Ahmed*, Md. Sultan Mahmud**</b> .....	432
EVA, ROCE, ROE, and EPS as Method of Assessment of Financial Performance and Its Effect on Shareholders' Wealth: Evidence From Bank Listed at Indonesian Stock Exchange in 2011 – 2013. ....	438
<b>Hamidah</b> .....	438
BackTrack System: Security against Hacking.....	445
<b>Munir A. Ghanem</b> .....	445

Civilization of the DACHL Countries Researching the Implementation of the D-A-CH-L Concept in Teaching German as a Foreign Language in R. Macedonia.....	448
<b>Valentina Ilieva</b> .....	448
Clinical and Endoscopic Study of Upper GI Manifestation in Corrosive Acid Ingestion.....	455
<b>Dr. B. Sudarsi, M.D. *</b> , <b>Dr. K.V.L. Sudha Rani, M.D. **</b> , <b>Dr. R. Siddeswari, M.D. ***</b> , <b>Dr. S. Manohar, M.D</b> **** .....	455
Stress and Public Sector Managers: A Case of the Government Officers in Nepal .....	460
<b>Kedar Rayamajhi</b> .....	460
Textile Application of Natural Colourant from the Roots of <i>Eichhornia crassipes</i> (Mart.) Solms .....	469
<b>Robin<sup>1</sup></b> , <b>Ashwani Kumar Thukral<sup>1</sup></b> and <b>Varinder Kaur<sup>2</sup></b> .....	469
Estimation of Soil Gas Radon Concentration and the Effective Dose Rate by using SSNTDs .....	479
<b>Abd-Elmoniem A. Elzain<sup>1,2</sup></b> .....	479
Thermodynamic interactions of l-histidine in aqueous fructose solutions at different temperatures .....	484
<b>K.Rajagopal *</b> , <b>J.Johnson **</b> .....	484
Techniques of Surveying and Cadastral Mapping in Vietnam .....	491
<b>Truong Quang Hien<sup>1,3</sup></b> , <b>Ma Cai Xue<sup>2,*</sup></b> , <b>He Li Yuan<sup>1,*</sup></b> .....	491
Power of Android Wearable Technology .....	498
<b>Saminath</b> .....	498
Comparison of Paravertebral Block with Spinal Anaesthesia in Unilateral Inguinal Hernia Repair .....	503
<b>Dr. Aswin.A.B<sup>1</sup></b> , <b>Dr. Suresh.Y.V<sup>2</sup></b> .....	503
Glycylglycine as Corrosion Inhibitor for Zinc Metal in Acid Solutions .....	507
<b>A.Pasupathy<sup>1</sup></b> , <b>T.Raja<sup>2</sup></b> , <b>M.Raja<sup>1</sup></b> .....	507
Triethylenetetramine as a Corrosion Inhibitor for Zinc Metal in Acidic Solutions.....	510
<b>A.Pasupathy<sup>1</sup></b> , <b>T.Raja<sup>2</sup></b> , <b>M.Raja<sup>1</sup></b> .....	510
Analysis and Simulation of Crankshaft Manufacturing Unit Using Arena .....	513
<b>Faisal KP<sup>1</sup></b> , <b>Falah Ummer<sup>1</sup></b> , <b>Hareesh K C<sup>1</sup></b> , <b>Munavir Ayaniyat<sup>1</sup></b> , <b>Nijab K<sup>1</sup></b> , <b>Nikesh P<sup>1</sup></b> , <b>Jibi R<sup>2</sup></b> ....	513
Navigation of Mobile Robot in the Presence of Static Obstacles of Various Shapes.....	520
<b>Barla Harshini*</b> , <b>Praveen kalla *</b> , <b>Dr K Ramji**</b> .....	520
A Performance Prediction of Worm-Worm Wheel and its Multi Objective Design Parameter Optimization Based on Genetic Algorithm.....	525
<b>Mokara Bharati*</b> , <b>V. DeepikaPoornima*</b> , <b>S.Jyothrimai*</b> .....	525
Hotel Revenue Management and Its advantages and Disadvantages to Organization, its employees and customers .....	531
<b>Noopur Sharma</b> .....	531
Experimental Investigation on Watt Governor to Increase Minimum Speed.....	533
<b>GiriBabu Surarapu<sup>1</sup></b> , <b>Shashidar PeddiReddy<sup>2</sup></b> , <b>Nagamani Uotkuri<sup>3</sup></b> .....	533
Students' Residential College Assessment through User Experience as a Component of Service Excellence .	537
<b>Musa Alkali Abubakar *</b> , <b>Rozilah Kasim *</b> , <b>Matthew Mamman **</b> .....	537
The effects of business ethics on consumers' perceptions of merchandizing and service giving businesses in Mekelle, Ethiopia.....	547
<b>Gebeyehu Jalu Negassa</b> .....	547
A Study to Assess the Effectiveness of Structured Teaching Programme on Knowledge regarding Substance Abuse among Adolescents at Selected Nursing Colleges of Udaipur District, Rajasthan, India .....	554
<b>Yogeshwar Puri Goswami<sup>1</sup></b> , <b>Dr. JayalakshmiL.S.<sup>2</sup></b> , <b>Dr. D.M. Mathur<sup>3</sup></b> .....	554
Evaluation of Water Quality Pollution Indices for Heavy Metal Contamination Monitoring in the Water of Harike Wetland (Ramsar Site), India.....	558
<b>Onkar Singh Brraich, Sulochana Jangu</b> .....	558
Adjustment among M.Tech students of Banasthali University .....	564
<b>Shweta Nema *</b> , <b>Dr. Suvidha **</b> , <b>Prof. Indu Bansal ***</b> .....	564

Correlates of Home Health Social Emotional Adjustment among Adolescence Girls.....	568
<b>Shweta Nema*</b> , <b>Prof. Indu Bansal**</b> .....	568
Review of literature on Correlates of Adjustment and Life Satisfaction among Middle Aged Married Couples .....	571
<b>Shweta Nema*</b> , <b>Prof. Indu Bansal**</b> .....	571
Impact of Corporate Social Responsibilities in Modern Business Environment.....	580
<b>Latika Verma</b> .....	580
India's Prime Minister Narendra Modi Visit to Nepal: Renewing Relations .....	584
<b>Tariq Rashid Wani</b> .....	584
Actual Transaction Behavior of Internet Banking Services among Iraqis Customers Using PLS Approach ....	586
<b><sup>1</sup>Alaa Ahmed Chyad Alkafagi, <sup>2</sup>Ruslan Bin Romli, <sup>3</sup>Ahmad Yusni Bin Bahaudin, <sup>4</sup>Jamal Mohammed Alekam, <sup>5</sup>Anas Abdelsattar Mohammad Salameh</b> .....	586
Adenoid Cystic Carcinoma of Nasal Cavity: A Rare Presentation Case Report.....	595
<b>Dr P K Purushothaman*</b> , <b>Dr R Ramakrishnan**</b> , <b>Dr P Sindhu**</b> .....	595
GM Food and Sustainable Development .....	598
<b>Dr. Afrina Rizvi</b> .....	598
Analysis of resection margins and lymph node dissection in laparoscopic assisted pancreatico-duodenectomy .....	603
<b>KB Galketiya*</b> , <b>MVG Pinto**</b> .....	603
A conceptual linkage between knowledge management, competitive advantage and competitive maneuverings of organizations.....	605
<b>Kashif Akram*</b> , <b>Nasir Mehmood**</b> , <b>Imran Khan***</b> .....	605
Depression Global Etic Findings about Gender, Income-groups and Localities; a Comparative Study .....	611
<b>Dr. Naveed Shibli, Hina Majid, Amana Zafar Ahsan, Amana Khalil, Moon Abdul Rauf, Salma Liaqat, Saira Yousaf, Iqbal Mehmood</b> .....	611
A Study on MSMEs' - Role in Propelling Economic Development of India & a Discussion on current HR issues in MSMEs' in India .....	613
<b>Mrs Ashu Katyal*</b> , <b>Mrs Betsy Xaviour**</b> .....	613
Effect of Cash Management on Financial Performance of Deposit Taking SACCOs in Mount Kenya Region	624
<b>Njeru Mugambi Duncan<sup>1</sup>, Dr. Agnes Njeru<sup>2</sup>, Dr. Florence Member<sup>3</sup>, Ondabu Ibrahim Tirimba<sup>4</sup></b> .....	624
Effects of water stress on yield and some yield components of three selected oil crops; Groundnut ( <i>Arachis hypogea L.</i> ), Sunflower ( <i>Helianthus annuus L.</i> ) and Sesame ( <i>Sesamum indicum L.</i> ) .....	630
<b>Dahanayake Nilanthi, Alawathugoda CJ and Ranawake AL</b> .....	630

# Differential pulse polarographic method development and validation of riboflavin in pharmaceutical formulation

L.M.Kashid\*, S.V.Patil\*\*

\* Department of Chemical Science, Vidya Pratishthan's, Arts, Science and Commerce College, Baramati, Pune, India

\*\* Department of chemistry, E.S. Divekar College, Varvand, Pune

**Abstract-** The development of differential pulse Polarographic (DPP) method for determination of riboflavin in pharmaceutical formulation was investigated. As first, we studied the electrochemical behaviour of riboflavin by DPP using a dropping mercury electrode (DME) as working and Hg/Hg<sub>2</sub>Cl<sub>2</sub>, Cl<sup>-</sup>(sat) as a reference electrode in Britton-Robinson (BR) buffer (pH 3.0–10). The results that were obtained showed that, the BR buffer solution with pH 7.0 was the best medium for reduction of riboflavin on the mercury electrode at peak potential (*E<sub>p</sub>*) -1.48 V. The range of linearity was found to be from 1.0 to 16.0 ppm with limit of detection of (LOD) 0.915 ppm and limit of quantification (LOQ) was 3.050 ppm with R<sup>2</sup> value was 0.997. Statistical analysis proved that the method was precise, reproducible, selective, specific, and accurate for analysis of riboflavin in pharmaceutical formulation.

**Keywords** - Riboflavin, Differential pulse polarography, Method validation.

## I. INTRODUCTION

Riboflavin is very important and essential vitamin for human nutrition, and growth. It plays a key role in biological reduction oxidation process and is available in various foods, but can be found easily in energy drinks, vitamin tablets and other vitamins supplements. These artificial sources are great for people who don't eat certain food that contains these vitamins, or are highly deficient. The deficiency of riboflavin can cause serious damage to our health and appearance.

There are number of electro-chemical methods used by many researchers for the determination of riboflavin includes spectrophotometer [1, 2], photochemical spectrophotometer [3], fluorometry [4, 5], HPLC [6], reverse-phase HPLC [7] and chromatography [8]. Various workers have carried out Polarographic [9], cathodic voltammetric as well as cyclic voltammetry studies of riboflavin [10]. The other specific powerful techniques are also available, which include normal or synchronous fluorescence, radioimmunoassay and enzyme-linked immunosorbent assay which use specific protein-binding selectivities [11]. The microbiological [12] methods of the Association of Official Analytical can also be applied for determination of riboflavin

A revision of the literature has given no evidence about DPP studies related to riboflavin in pharmaceutical formulation.

Considering the great advantage of DPP, we have studied electrochemical characterization of riboflavin in pharmaceutical preparation by DPP.

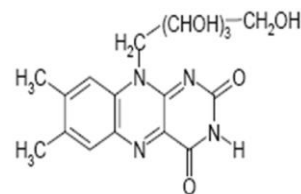


Figure1: Chemical structure of riboflavin

## II. MATERIALS AND METHOD

### A. Chemicals

The reference standard riboflavin solutions and supporting electrolyte, BR buffer, 0.04 M was prepared in doubly distilled water. The purity of reference standards were 99.9%. All other reagents employed were of analytical grade and used without further purification.

### B. Instrumentation

Polarographic analyzer model CL-362 supplied by an Elico Ltd, Hyderabad with PC through its RS 232C interface with the help of ELICO's windows based software were used for polarographic measurements. A dropping mercury as a working electrode, saturated calomel as reference and platinum wire as auxiliary electrodes was used. Spectrophotometric measurement was carried out using UV-VIS spectrophotometer, PerkinElmer Lambda 25, in 1 cm quartz cell. All measurements were made at room temperature.

### C. Calibration curve preparation

For DPP studies, a series of nine solutions were prepared in BR buffer pH 7.0 as a supporting electrolyte containing riboflavin concentrations ranging from 1ppm-16 ppm. Each standard and sample solution was transferred in a polarographic cell, degassed with nitrogen by 5 min. and polarograms (Figure 3) were recorded from - 3.0 V to -1.6 V at optimized parameter (Table 1)

For UV-Visible spectroscopic studies, 15 ppm riboflavin was prepared in 0.04 M BR buffers. The solution was scanned in UV-Visible spectrophotometer in the range 200nm-800nm using

0.04 M BR buffer as a blank. The wavelength corresponding to maximum absorbance ( $\lambda_{max}$ ) was found at 444.91 nm. The calibration curve was constructed by taking standard solutions used in DPP (**Figure 6**)

#### D. DPP assay for tablets

The oral tablet containing 25 mg of riboflavin was purchased from local market and suspended in 25.0 mL distilled water. A 1.0 mL aliquot of each solution was taken and diluted to 50 mL with 0.04M BR buffer solution, pH 7.0. Each sample solution was transferred in a polarographic cell, degassed with nitrogen by 5 min. and recorded at least thrice from -3.0 V to -1.6 V; the concentration of riboflavin in the sample solution were calculated from regression equation prepared from standard calibration curve.

#### E. UV-Vis spectrophotometry assay for tablets

The oral tablet containing 25 mg of riboflavin was purchased from local market and suspended in 25.0 mL distilled water, sonicated and centrifuged at 3000 rpm. A 1.0 mL aliquot of each solution was taken and diluted to 50 mL with 0.04M BR buffer solution, pH 7.0. Each one sample solution was measured at 444.91 nm, and the concentration of riboflavin in the sample solution was calculated from regression equation prepared for standard calibration curve.

### III. METHOD VALIDATION

The DPP method was validated according to international guidelines for bioanalytical methods, including stability of analyte, determination of specificity and selectivity, calibration curve, detection and determination limits, accuracy, and inter-day and intraday precision

#### A. Linearity and Detection Determination Limits

The linearity of the method was checked by constructing a plot of different concentration of riboflavin versus corresponding peak current ( $I_p$ ) at peak potential. The solution was scanned from -3.00 V to -1.6 V, for varying the riboflavin concentration ranging from 1.0 ppm to 16.0 ppm in 0.04M BR buffer solution, pH 7.0 (**Figure 4**). The LOD and LOQ for the proposed method were calculated according to the equation  $LOD = 3\sigma/m$  and  $LOQ = 10\sigma/m$ , where  $\sigma$  represents standard deviation of the slope (m) (**Table 1**)

#### B. Accuracy

To check the degree of accuracy of the method, recovery experiments were performed by tablets assay of riboflavin containing excipients (Dicalcium Phosphate, Microcrystalline Cellulose, Vegetable Stearic Acid, Silica, Vegetable Cellulose, and Vegetable Magnesium Stearate.) according to manufacturer's batch formulation for 25 mg riboflavin per tablet. Accuracy was assessed as the % recovery (**Table 2**).

#### C. Precision

Precision study was performed for intra-day and inter-day variation of different solutions of same concentration, were analyzed three times in a three day and the peak current at peak potential is noted. From the  $I_p$  mean, standard deviation and %RSD was calculated (**Table 3**). These values were well within the limit of ICH guidelines.

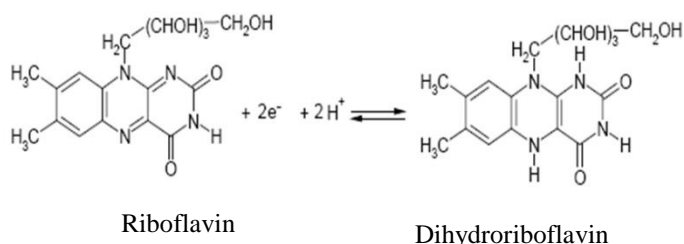
#### D. Selectivity

The specificity was evaluated by analyzing solutions containing the excipients employed for the preparation of riboflavin in commercial tablets.

### IV. RESULTS AND DISCUSSION

#### A. DPP behaviour of riboflavin

The reversibility of reduction mechanism of riboflavin was investigated at DME by using DPP in BR buffer at different pH in the range of 2-11. Riboflavin produces a well defined peak in a wide range of pH from 2.0 to 8.0. It was observed that sharp and well-defined DPP response was obtained at pH 7.0. Therefore the analytical studies were performed at pH 7.0. At this pH it was found that  $I_p$  is directly proportional to the vitamin concentration in the solution. The proposed reduction mechanism at pyridine ring of riboflavin is due to two-electron reduction to generate the dihydroriboflavin derivative in BR buffer (**Figure 2**).



**Figure 2:** The proposed reduction mechanism of riboflavin

#### B. Optimization of instrumental conditions

The DPP determination of vitamin at trace level normally involves very small current responses. Therefore optimization of instrumental and experimental parameters has been performed for 10 ppm as highest concentration in BR buffer at optimized pH 7.0.

#### C. Effect of pulse amplitude and scan rate

The effect of pulse amplitude on the sensitivity of  $I_p$  and  $E_p$  was checked in the range of 5.0 to 100 mV with optimum conditions. The results showed that the  $I_p$  were increased by increasing pulse amplitude to 50 mV, and then leveled off. This is due to the fact, after 50 mV, the peak current broadened. Thus, 50 mV pulse amplitude was selected. Also the influence of scan rate on the  $I_p$  and  $E_p$  of riboflavin was studied in the range of 3 to 12 mV/s. The scan rate of 6 mV/s would be the best



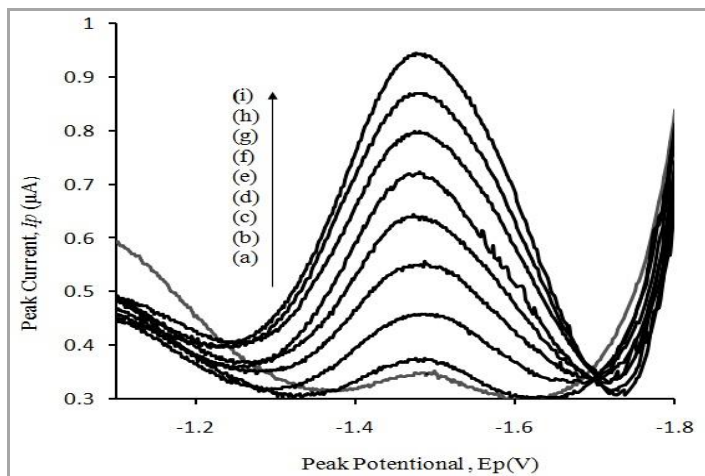
compromise when considering the sensitivity, resolution and speed requirements and was used throughout the analysis of vitamin.

**Table.1:** Optimized analytical parameters for determination of riboflavin

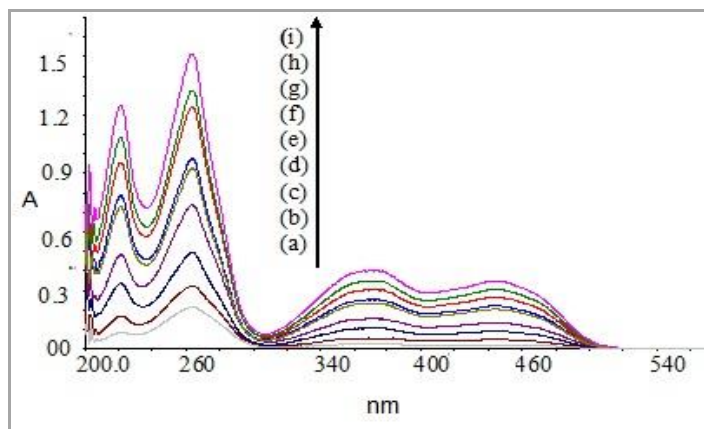
Instrumental Parameter	DPP	Analytical Parameter	Validation
Peak potential (V)	-1.484	Optimum pH	7.0
Pulse amplitude (mV)	50.0	Concentration range (ppm)	1.0-16.0
Scan rate (mV/sec)	6.0	LOD (ppm)	0.915
Current range (μA)	10.0	LOQ(ppm)	3.050
Drop time (sec)	1.0	Correlation coefficient (r)	0.997
Scan type	Forward	Slope (ppm)	0.04
CC Compensation (%)	0.00	Intercept (μA)	0.305
Data acquisition	Slow	Standard deviation	0.09075

**D. Validation of the analytical method**

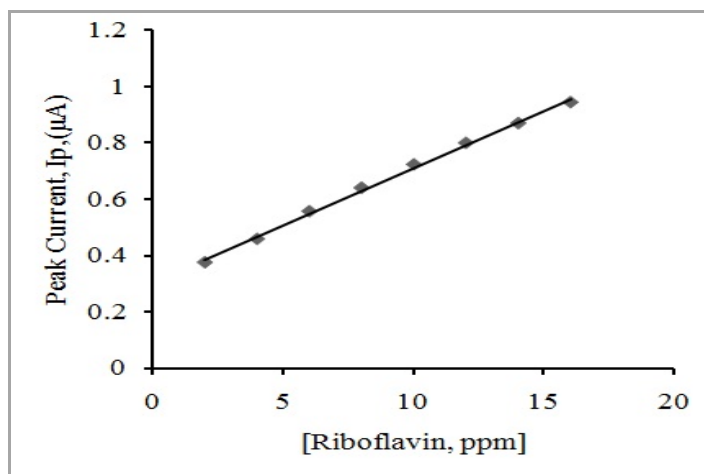
The analytical validation study was carried out using optimum parameters to observe a relationship between  $I_p$  and concentration of riboflavin. The calibration curve was prepared by a series of standard solution of vitamin. When the concentration of riboflavin was varied, the  $I_p$  increased successively. It shows that the range of linearity was found to be from 1.0 ppm to 16 ppm (**Figure 4**).



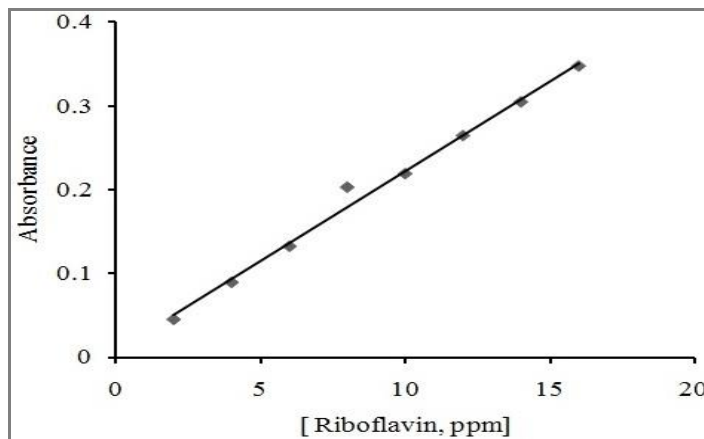
**Figure 3:** DPP polarogram of riboflavin at pH 7.0 in BR buffer solution obtained at a) 1.0 ppm, b) 2.0 ppm, c) 4.0 ppm, d) 6.0 ppm, e) 8.0 ppm, f) 10.0 ppm, g) 12.0 ppm, h) 14.0 ppm, i) 16.0 ppm.



**Figure 5:** UV/Vis spectrum of riboflavin at pH 7.0 in BRB buffer solution obtained at a) 1.0 ppm, b) 2.0 ppm, c) 4.0 ppm, d) 6.0 ppm, e) 8.0 ppm, f) 10.0 ppm, g) 12.0 ppm, h) 14.0 ppm, i) 16.0 ppm,



**Figure 4:** Linear plot of  $I_p$  versus concentration of riboflavin at pH 7.0 in BR buffer



**Figure 6:** Linear plot of absorbance versus concentration of riboflavin at pH 7.0 in BR buffer

**E. Analytical applications**

Based on the greater resolution and sensitivity of instruments, DPP and UV technique were applied for quantification in working pH of 7.0. For assay, the calibration plot method was used, obtained from nine points between 1 ppm and 16 ppm expressed by the following equation

$$DPP \quad I_p = 0.04 \times C + 0.305 \quad (R^2 = 0.997, n=9)$$

$$UV \quad A = 0.021 \times C + 0.008 \quad (R^2 = 0.991, n=9)$$

where  $I_p$  is the peak current,  $C$  is the riboflavin concentrations in ppm,  $R^2$  is the regression coefficient and  $A$  is absorbance

**Table 2:** Recovery of riboflavin from 25 mg per tablet samples by DPP and UV-Vis spectrophotometry

Sample	DPP	UV/Vis
01	98.03	97.36
02	97.23	98.12
03	96.89	98.65
04	97.24	97.89
05	98.26	96.00
06	97.03	98.06
07	96.05	98.89
Average	97.24	97.95
SD	± 0.7465	± 0.9576
%RSD	± 0.7676	± 0.9786

The recovery study in **Table 2** indicates that both DPP and UV-Vis spectrophotometric techniques are adequately precise and accurate with % RSD lower than 1% and percentage of recoveries near 98%. It is recommended for the determination of riboflavin in pharmaceutical formulation.

**Table 3:** Precision studies by the proposed DPP procedure (n=3)

Riboflavin Vitamin (ppm)	Intraday measurement $I_p \pm SD$ (%RSD)	Interday measurement $I_p \pm SD$ (%RSD)		
		1 day	2 day	3 day
4	0.4848 ± 0.0074 (%1.443)	0.4848 ± 0.0074 (%1.443)	0.462 ± 0.0016 (%3.528)	0.4664 ± 0.0061 (%1.300)
8	0.630 ± 0.0066 (%1.046)	0.630 ± 0.0066 (%1.046)	0.6288 ± 0.0082 (%1.30)	0.6121 ± 0.0088 (%1.452)
12	0.7812 ± 0.0092 (%1.180)	0.7812 ± 0.0092 (%1.180)	0.7792 ± 0.0108 (%1.380)	0.7689 ± 0.0120 (%1.560)

## F. Conclusion

The proposed DPP method is accurate, precise, reproducible, specific, fast, low cost and stability-indicating methods. The DPP method has a great potential as an alternative method for this application in the future and successfully developed for the determination of riboflavin in pharmaceutical formulations in the presence of other commonly occurring ingredients

## ACKNOWLEDGMENT

The work has been carried out under BCUD research project, Savitribai Phule Pune University, Ganeshkhind, Pune, and their financial support is acknowledged. The authors also would like to thank Principal, Vidya Pratishthans, Arts, Science and Commerce College for giving all possible facilities to carry out the research work.

## REFERENCES

- [1] M.H.Hashmi, A.I.Ajmal, T.Qureshi T, A. Rashid, "Spectrophotometric determination of riboflavin from pharmaceutical preparations", *Microchim Acta*.vol. 57(1), 1969 pp. 30-35.
- [2] .H.Shah, S.Patel, B.Patel, N.Solanki, N.P.Jivani, D.B.Kumar, "Development and Validation of UV-Visible Spectrometric Method for estimation of Water Soluble Vitamin Riboflavin", *Int J Pharm Sci Res*. Vol. 3(9), 2012, pp. 3462-3466.
- [3] T. Perez-Ruiz, C.Martínez-Lozano, V. Tomas and O. Val, "Photochemical spectrophotometric determination of riboflavin and riboflavin 5-phosphate by manual and flow injection methods", *Analyst*. Vol.119, 1994, pp. 1199-1203
- [4] L.F. Russell, J. T. Vanderslicea, "Comments on the standard fluorometric determination of riboflavin in foods and biological tissues", *Food Chemistry* vol. 43, 1992, pp. 79-82.
- [5] K.Helrich, "Official Methods of Analysis of the Association of Official Analytical Chemicals", 13th ed.; Association of the Official Analytical Chemists, Arlington Inc: VA, 1990, pp. 65:970, 15:981.
- [6] S.M. Fernando, P.A. Murphy, "HPLC determination of thiamine and riboflavin soy-beans", *J. Agric. Food Chem*.vol.38, 1990, pp.163-167.
- [7] G. Brubacher, W.Müller-Mulot, "Vitamin B2 (Riboflavin) in Foodstuffs: HPLC Method, in Methods for the determination of Vitamins in Food-Recommended by COST 91", Elsevier Applied Science: New York, 1985.
- [8] G.Swiglo, A.Koziolowa, "Chromatographic determination of riboflavin and its derivatives in food", *J. Chromatogr.*, A vol. 881, 2000, pp.285-297
- [9] J.Lingane, J.Davis, "Polarographic determination of riboflavin (vitamin b2) and other vitamin b factors", *J. Biol. Chem*.vol.137 (2), 1941, pp. 567-574.
- [10] W.Hussein, D.Waqar, "Cyclic voltammetric adsorption behaviour of riboflavin at platinum electrode", *Pak. J. Pharm. Sci*.vol. 5(2), 1992, pp.139-145.
- [11] G.Brubacher, W.Mueller-Mulot and D.A.T.Southgate, "Methods for determination of vitamins in food" Elsevier, New York, 1985.
- [12] K. Helrich, "Official Methods of Analysis of the Association of Official Analytical Chemicals", 13th ed.; Association of the



Official Analytical Chemists, Arlington Inc: VA, 1990, Vol. 33, pp. 940.

[13] ICH; Guidelines Q2B Validation of Analytical Procedures: Methodology. International Conferences on Harmonization. Geneva, 1996.

[14] Analytical Methods Committee; Recommendations for the definition, estimation and use of the detection limit. Analyst 112:1987: 199- 204.

[15] ICH; draft Guidelines on Validation of Analytical Procedures, Definitions and Terminology, Federal Register, 60, IFPMA, Switzerland, 1995:1260.

#### AUTHORS

**First Author** – L.M.Kashid, M.Sc.; M.Phil.; Ph.D, Department of Chemical Science, Vidya Pratishthan's, Arts, Science and Commerce College, Baramati, Pune, India, [lmkashid@gmail.com](mailto:lmkashid@gmail.com),

**Second Author** – S.V. Patil, M.Sc.; SET, \*\* Department of Chemistry, E.S. Divekar College, Varvand, Pune

**Correspondence Author** – L.M.Kashid, [lmkashid@gmail.com](mailto:lmkashid@gmail.com), contact number. +919860001643

# Perinatal outcome in antepartum hemorrhage in teaching hospital of northern India- A prospective study

Shaveta Jain \*, Nitin Jain \*\*, Pushpa Dahiya \*, Seema Rohilla \*\*, Roopa Malik \*

\*Department of obs&Gynae Pt. B.D Sharma, PGIMS, Rohtak, Haryana, India

\*\*Department of Radiology Pt. B.D Sharma, PGIMS, Rohtak, Haryana, India

**Abstract-** Antepartum hemorrhage (APH) is a grave obstetrical emergency. It is leading cause of perinatal death. Aims of the present study were to study perinatal outcome in patients with antepartum hemorrhage. It is a prospective study carried out over a period of one year (2011-12) on 100 women admitted with the diagnosis of APH at Pt. B.D Sharma medical college, Rohtak, Haryana, India, a tertiary care center. Perinatal outcome recorded according to gestational age, Apgar score, mode of delivery, weight of baby, neonatal mortality and morbidity. Perinatal mortality was higher in vaginally delivered patients (71.4%) in comparison to patients who had caesarean section (53.8%) in abruptio placentae cases. Perinatal mortality decreases with increasing baby weight in placenta previa cases, while perinatal mortality is even high in babies more than 2500 gm in abruptio placentae cases. 79% babies had low apgar score and perinatal mortality in this group was 50.6% while 21% babies with higher Apgar  $\geq 7$  had mortality of 4.7% only.

**Index Terms-** Antepartum hemorrhage, perinatal, placenta previa, abruptio placentae

## I. INTRODUCTION

Vaginal bleeding at any stage of pregnancy constitutes a significant concern to the patients and her doctor. Antepartum hemorrhage is still a grave obstetric emergency contributing to a significant amount of perinatal morbidity and mortality in India.<sup>1</sup>

Perinatal mortality is less than 10 per 1000 total births in developed countries, while it is much higher in developing countries (31/1000 total births in India in 2011).<sup>2</sup>

Depending on the definition used, antepartum hemorrhage complicated 2-5% of all pregnancies.<sup>3-5</sup> Placenta previa complicate 0.33 percent<sup>6</sup> to 0.55 percent<sup>7</sup> of all pregnancies and

incidence of placental abruption incidence is approximately 0.5 to 1 percent.<sup>8</sup>

Though Perinatal mortality due to antepartum hemorrhage has significantly dropped in developed countries with the introduction of improved medical facilities, in developing countries, it is one of the most important cause of perinatal mortality and morbidity. Knowing the outcome of fetus with Antepartum hemorrhage is important set out policies to reduce perinatal mortality of most vulnerable group.

**Abbreviation used-** IUFD- Intrauterine fetal death, PND- Perinatal death, PM, Perinatal mortality

## II. MATERIAL AND METHODS

A prospective study was carried out in 2011-12 on 100 pregnant women presenting with bleeding per vaginum after 28 weeks of gestation or in which on routine ultrasonography major degree placenta previa was diagnosed in the Department of Radiology, Pt. B.D. Sharma PGIMS, Rohtak, a tertiary care hospital in Haryana, India

During our study period of one year there were 4100 deliveries. Number of cases with antepartum hemorrhage were noted and perinatal outcome of patient with antepartum hemorrhage recorded including status of fetus, relation of perinatal death to Gestational age & baby weight, Apgar score, mode of treatment, cause of perinatal mortality and morbidity.

### Statistical analysis

At the end of the study, pairwise comparisons for morbidity and mortality were performed with Fisher's exact test and Chi-square tests were applied for discrete variables. p value of less than 0.05 was considered to indicate statistical significant.

## III. RESULTS

**Table 1**  
**Perinatal outcome**

Causes	Number of cases		Still birth + IUFD		Neonatal death		Total perinatal mortality*	
	No.	%age	No.	%age	No.	%age	No.	%age
Placenta previa	54	54	6	11.1	10	18.5	16	29.6
Abruptio	34	34	14	41.1	8	23.5	22	64.7
Toxemia	10	29.4	7	70	2	10	8	80

Non toxemia	24	70.5	7	29.1	6	29.1	14	58.3
Unclassified	12	12	2	16.6	1	8.3	3	25

\*p<0.001, Fisher's Exact Test

Perinatal mortality in our present study in placenta previa cases was 29.6%, while in cases of abruptio placentae perinatal mortality was 64.7% and on comparing it was statistically significant (p<0.001). In patients having abruptio placentae with toxemia perinatal mortality was 80%.

**Table 2**  
**Analysis of mode of treatment given to the patients and the perinatal outcome in antepartum hemorrhage**

Mode of treatment	Placenta previa				Abruptio placentae				Unclassified hemorrhage			
	No.	%age	PM	%age	No.	%age	PM	%age	No.	%age	PM	%age
Conservative followed by LSCS	22	44.4	4	18.2	-	-	-	-	-	-	-	-
Conservative followed by vaginal delivery	6	11.1	1	16.6	-	-	-	-	-	-	-	-
Immediate LSCS	22	40.7	9	40.9	13	24	7	53.8	4	33.3	1	25
Immediate vaginal delivery	4	7.4	2	50	21	61.7	15	71.4	8	66.6	2	25
Total	54		16		34		22		12		3	

40.7% patients of placenta previa had immediate LSCS. 44.4% patients of placenta previa were kept on conservative management and later LSCS was done after expectant management. 61.76% of patients of abruptio placentae had immediate vaginal delivery. Perinatal mortality in abruptio placentae cases delivered vaginally was 71.4%, while patients delivered by immediate LSCS had perinatal mortality of 53.8%.

**Table 3**  
**Status of fetus**

Status of fetus	Placenta previa		Abruptio placentae		Unclassified hemorrhage		Total	
	No.	%age	No.	%age	No.	%age	No.	%age
Normal fetal heart sound	39	72.2	13	38.2	8	66.6	60	60
Evidence of fetal distress	9	16.6	7	20.5	2	16.6	18	18
Absent fetal heart sound	6	11.1	14	41.1	2	16.6	22	22

72% patients of placenta previa had normal fetal heart sound at time of admission while 41.1% patients of abruptio placentae had absent fetal heart sound at time of admission.

**Table 4**  
**Incidence of perinatal mortality in relation to gestational age**

Type of antepartum hemorrhage	Term			Preterm			Total		
	No.	PND	%age	No.	PND	%age	No.	PND	%age
Placenta previa	12	2	16.6	42	14	33.3	54	16	29.6
Abruptio placentae	9	4	44.4	25	18	72	34	22	64.7
Unclassified hemorrhage	3	1	33.3	9	2	22.2	12	3	25
Total	24	7	29	76	34	44.7	100	41	41

Perinatal mortality in preterm babies was 72% in cases of abruptio placentae and 33.3% in cases of placenta previa .

**Table 5**  
**Incidence of perinatal mortality according to baby weight in antepartum hemorrhage**

Birth weight	Placenta previa			Abruptio placentae			Unclassified hemorrhage			Total		
	No.	PND	%age	No.	PND	%age	No.	PND	%age	No.	PND	%age
Below 1500gm	4	4	100	3	3	100	1	1	100	8	8	100
1500 to 2000gm	17	7	41.1	15	10	66.6	4	1	25	36	18	50
2000 to 2500gm	20	3	15	8	5	62.5	5	1	25	33	9	27.2
Above 2500gm	13	2	15	8	4	50	2	-	-	23	6	26
Total	54	21		34	26		12	3		100	50	50

Perinatal death was 100% in babies weighing <1500 gm, 50% in babies weighing 1500 to 2000 gm, 27.2% in 2000 to 2500 gm, 26% for more than 2500 gm. Perinatal mortality was even high in babies more than 2500 gm in abruptio placentae.

**Table 6**  
**Incidence of congenital malformation in antepartum hemorrhage**

Type of congenital malformations	Placenta previa	Abruptio placenta	Unclassified hemorrhage
Hydrops foetalis Indeterminate sex	1	-	-
Anencephaly with meningocoele	1	-	-
Spina bifida	-	1	-
Total	2	1	1

Out of 100 cases of antepartum hemorrhage 4 had congenital malformations (4%).

**Table 7**  
**Distribution of cases according to neonatal mortality in baby in cases of antepartum hemorrhage**

Cause of neonatal mortality	Placenta previa (n=10)		Abruptio placenta (n=8)		Unclassified hemorrhage (n=1)		Total (n=19)	
	No.	%age	No.	%age	No.	%age	No.	%age
Prematurity	5	50	4	50	1	100	10	52.6
Neonatal septicemia	3	30	3	37.5	-	-	6	31.5
Respiratory distress syndrome (RDS)	3	30	2	25	-	-	5	26.3
Birth asphyxia	3	30	3	37.5	-	-	6	31.5
Congenital malformation	1	10	1	12.5	-	-	2	10.52
Hyaline membrane disease	3	30	2	25	1	100	6	31.5
Neonatal seizures	2	20	2	25	-	-	4	21
Apnoea	2	20	2	25	-	-	4	21

The causes of mortality outnumber the number of neonatal deaths showing that there was more than one cause of death in a neonate.

Placenta previa:

Total number of live birth = 46

Abruptio placenta:

Total number of live birth = 16

Unclassified hemorrhage:

Total number of live birth = 10

Prematurity was cause of neonatal mortality in 5 cases of placenta previa, 4 cases of abruptio placentae and 1 case of unclassified hemorrhage. Birth asphyxia caused neonatal death in 3 cases of placenta previa and 3 in abruptio placentae.

**Table 8**  
**Incidence of perinatal death in relation to apgar score (1 min) in cases of antepartum hemorrhage**

Apgar score (1 min)	Placenta previa				Abruptio placenta				Unclassified hemorrhage			
	No.	%age	PM	%age	No.	%age	PM	%age	No.	%age	PM	%age
0-4	20	37	10	50	24	70.5	18	75	6	50	3	50
5-6	18	33.3	5	27.7	8	23.6	4	50	3	25	-	-
7 or more	16	30	1	6.2	2	5.8	-	-	3	25	-	-
Total	54		16		34		22		12		3	

Perinatal mortality was higher in babies having Apgar score 0-7 than babies having Apgar score 7 or more. 37% babies of placenta previa had apgar score between 0-4, 33.3% between 5-6 and 30% more than 7. 70.5% of abruptio placentae cases had apgar score between 0-4.

**Table 9**  
**Incidence of neonatal morbidity in cases of antepartum hemorrhage**

Cause of neonatal mortality	Placenta previa n=46		Abruptio placentae n=16		Unclassified hemorrhage n=10	
	No.	%age	No.	%age	No.	%age
Prematurity	20	56.5	3	18.7	2	20
Respiratory distress syndrome (RDS)	3	6.5	1	6.25	-	-
Hyaline membrane disease (HMD)	4	8.6	1	6.25	1	10
Birth asphyxia (BA)	11	24	3	18.7	1	10
Neonatal septicemia (NNS)	4	8.6	2	12.5	1	10
Neonatal jaundice (NNJ)	3	6.5	1	6.25	-	-
Meconium aspiration	1	2.1	2	12.5	-	-

Prematurity (43.4%) and birth asphyxia (24%) were most common cause of neonatal morbidity in placenta previa babies, while prematurity (18.7%) and birth asphyxia (18.7%) were also most common cause of morbidity in abruptio patient babies.

**Table 10**  
**Sex ratio in antepartum hemorrhage**

	Number	Boys*	%age	Girls	%age	Indeter-minated sex	%age
Placenta previa	54	34	63	20	37%		
Abruptio placenta	34	20	58.8	14	41.1		
Unclassified hemorrhage	12	4	33.3	7	58.3	1	8%

\*p>0.01, Chi-square test

Out of 54 cases of placenta previa, 34 women delivered male babies (63%) and 34 cases of abruptio placenta, 20 women had male babies (58.8%). However, both were not statistically significant (p>0.01).

#### IV. DISCUSSION

Antepartum hemorrhage is an important cause of perinatal morbidity and mortality [Table-1].

In present study patients of placenta previa who delivered vaginally (11.1%) after conservative management show comparable perinatal mortality (16.6%) to those patient delivered by caesarean section (18.2%) [Table-2]. All these cases are of low lying and marginal placenta previa. Similarly Chevenak et al suggested that routine caesarean section is not necessary for all cases of partial placenta previa.<sup>9</sup> MaCafee and Johnson also suggested similarly that vaginal delivery is appropriate in selected in cases of placenta previa.<sup>10</sup>

Perinatal mortality was higher in vaginally delivered patients (71.4%) in comparison to patients who had caesarean section (53.8%) in abruptio placentae cases [Table-2]. This is consistent with study of Okonofua and Olatunboson where perinatal mortality in vaginally delivered group (52.2%) was significantly greater than caesarean (16.7%).<sup>11</sup> This suggested that early delivery of fetus by caesarean in abruptio placentae save the infant from deleterious effect of ongoing anoxia.

Patients with placenta previa delivering at term gestation [Table-4] had perinatal mortality of 16.6% in comparison to 33.3% who delivered at gestation  $\leq 36$  weeks. Khosla et al in their study reported perinatal mortality in placenta previa as 61.5% and 75.3% in term and preterm gestation respectively.<sup>12</sup> The difference in result in our study are most likely due to better neonatal intensive care unit facilities optimal blood transfusion and more liberal use of caesarean section.

In our study perinatal mortality was 100% in patients of antepartum hemorrhage delivering baby less than 1500 gm. Perinatal mortality decreases with increasing baby weight in placenta previa cases, while perinatal mortality is even high in babies more than 2500 gm in abruptio placentae cases [Table-5]. This shows that abruptio placenta is a major contributor in perinatal mortality at every gestational age ( $p < 0.01$ ). Our result is consistent with result of Arora et al who showed higher perinatal mortality in abruptio group (53.5%) than placenta previa (25%).<sup>1</sup>

Our study shows 4% congenital malformation [Table-6] in antepartum hemorrhage cases that is consistent with Brenner et al who reported incidence of 3-4% in antepartum hemorrhage cases.<sup>13</sup>

Our study shows prematurity as the most common cause of neonatal death in cases of Antepartum hemorrhage (52.6%) [Table-7]. This is consistent with studies of Crane et al who reported prematurity as the most common cause of death in antepartum hemorrhage cases (46.5%).<sup>14</sup> Various other causes of neonatal mortality in our study are respiratory distress syndrome 26.3%, Hyaline membrane disease 31.5%, neonatal septicemia 31.5%, Birth asphyxia 31.5%. This is consistent with study of Arora et al who reported 38% incidence of birth asphyxia in antepartum hemorrhage cases.<sup>1</sup>

In present study 79% babies had low apgar score and perinatal mortality in this group was 50.6% while 21% babies with higher Apgar  $\geq 7$  had mortality of 4.7% only [Table-8]. Result of present study are comparable to other studies in literature.<sup>1,13</sup>

Our study showed 63% and 58.8% male fetus i.e. male dominance in cases of placenta previa and abruptio placenta [Table-10]. Similar findings are reported in literature.<sup>15, 16</sup> But

in our study it was not statistically significant ( $p > 0.01$ ). This may be due to small sample size of our study. Jakobovits et al conducted study on 144 infants of placenta previa cases and 26,858 case of normal pregnancy. Placenta previa cases had 90 male child and 54 female, while comparison group have 13,833 male and 13,025 female which showed that their association between placenta previa and male sex at birth.<sup>17</sup>

#### V. CONCLUSION

Analyzing the incidence of perinatal death in cases of antepartum hemorrhage, we observed that it is still a significant problem in our setup. Though maternal mortality has reduced with modern management of antepartum hemorrhage, perinatal mortality still remains high.

The single most important factor in reducing maternal and perinatal mortality has been the increase use of caesarean delivery in cases of abruptio placentae. Vaginal delivery is appropriate in selected cases of placenta previa.

The use of present day aids like, ultrasonography to decide about the time of interventions and the more liberal use of caesarean section in well equipped hospitals with availability of blood transfusion services, will help to lower the perinatal morbidity and mortality.

#### REFERENCES

- [1] Arora R, Devi U, Majumdar K. Perinatal morbidity and mortality in antepartum haemorrhage. *J Obstet Gynaecol India* 2001; 51(3): 102-4.
- [2] <http://data.worldbank.org/indicator/SH.DYN.NMRT>
- [3] Hibbard BM, Jeffcoate TNA. Abruptio placentae. *Obstet Gynecol* 1966; 27: 155-67.
- [4] Chamberlan GVP, Philipp E, Howlett B, Masters K. *Br Birth Obstet Gynecol* 1970; 45: 160-3.
- [5] Green JR. Placenta abnormalities: Placenta previa and abruptio placentae, Maternal fetal medicine. In: Creasy RK, Resnik R, editors. *Principle and Practice*. 3rd edition. Philadelphia, WB Saunders, 1989; 588-602.
- [6] Crane JMG, Van Denhof MC, Dodds L, Armson A, Listen R. Neonatal outcomes with placenta previa. *Obstet Gynecol* 1999; 93: 541-4.
- [7] Frederiksen MC, Glassenberg R, Stika CS. Placenta previa: A 22 year analysis. *Am J Obstet Gynecol* 1999; 180: 1432-6.
- [8] Ananth CV, Smulian JC, Vintziteos AM. Incidence of placental abruption in relation to cigarette smoking and hypertensive disorders during pregnancy: a meta-analysis of observational studies. *Obstet Gynecol* 1999; 93: 622-8.
- [9] Chevenak FA, Lee Y, Hendlee MA, Monson RF, Berkowitz RL. Role of attempted vaginal delivery in the management of placenta previa. *Obstet Gynecol* 1984; 64: 798-82
- [10] MaCafee CHG, Johnson R. Placenta previa: A study of 174 cases. *J Obstet Gynaecol Br Emp* 1945; 52: 313-9.
- [11] Okonofua FE, Olatunboson OA. Caesarean versus vaginal delivery in abruptio placentae associated with live fetuses. *Int Fed Gynecol Obstet* 1985; 23: 471-4.
- [12] Khosla A, Dahiya V, Sangwan K, Rathor S. Perinatal outcome in antepartum haemorrhage. *J Obstet Gyn India* 1989; 9: 71-3.
- [13] Brenner WF, Edelman DA, Hendricks CH. Characteristics of patients with placenta previa and results of expectant management. *Am J Obstet Gynecol* 1975; 155: 180-4.
- [14] Crane JMG, Van Denhof MC, Dodds L, Armson A, Listen R. Neonatal outcomes with placenta previa. *Obstet Gynecol* 1999; 93: 541-4.
- [15] Krohn M, Voigt L, McKnight B, Daling JR, Starzyk P, Benedetti TJ. Correlates of placenta abruption. *Br J Obstet Gynecol* 1987; 94: 333-40.

- [16] Demissie K, Brekenridge MB, Joseph L, Rhoads GG. Placenta previa: preponderance of male sex at birth. *Am J Epidemiol* 1999; 149: 824-30.
- [17] Jakobovits AA, Zobek L. Sex ratio and placenta previa. *Acta Obstet Gynecol Scand* 1989; 68: 503-5.

#### AUTHORS

**First Author** – Shaveta Jain , M.S, Pt B.D Sharma, PGIMS, Rohtak, India, Dr\_sangwan@yahoo.com

**Second Author** – Nitin Jain, D.M.R.D, Pt. B.D Sharma, PGIMS, Rohtak, India,logindrnitin@gmail.com

**Third Author** – Pushpa Dahiya, M.D, Pt.B.D Sharma, PGIMS, Rohtak, India. Pushpadahiya@yahoo.com

**Fourth Author-** Seema Rohilla, M.D, Pt.B.D Sharma, PGIMS, Rohtak, India, seemarohilla@yahoo.co.in

**Fifth Author-** Roopa malik, M.D, Pt.B.D Sharma, PGIMS, Rohtak, India, drroopa.sangwan@gmail.com

**Correspondence Author** – Nitin Jain, House no 629, Sector 14, Rohtak, Haryana, India-124001 logindrnitin@gmail.com  
+91946811295,911262279302



# Amitriptyline Effect on Tumor Necrosis Factor- $\alpha$ , Interleukin-1 and Interleukin-6 Serum Level and its Correlation with Pain Severity in Chronic Tension-Type Headache Patients

Aldy S. Rambe\*, Hasan Sjahrir\*, Moh. Hasan Machfoed\*\*

\*Department of Neurology University of Sumatera Utara, School of Medicine, Medan Indonesia

\*\*Department of Neurology Airlangga University, School of Medicine, Surabaya Indonesia

**Abstract-** Introduction : Chronic tension-type headache (CTTH) differs from the episodic form not only in frequency but also with respect to pathophysiology, lack of effect to most treatment strategies, frequent medication overuse, more disability, and higher socioeconomic costs. The purpose of this study is to see the effect of amitriptyline on TNF- $\alpha$ , IL-1, and IL-6 serum levels in CTTH patients and its correlation with pain severity.

Method : This research was done at the Adam Malik Hospital and Bukit Barisan Army Hospital Medan, Indonesia from January 2013 - June 2014 and approved by the Ethics Committee for Health Research School of Medicine in University of Sumatera Utara. The subjects were recruited consecutively from study population. Diagnosis of CTTH was based on the diagnostic criteria as stated in the ICH X. We assessed pain severity by using the Numeric Rating Scale ( NRS ) for pain. Venous blood was taken to measure serum levels of TNF- $\alpha$  , IL-1, and IL-6. After subjects were given amitriptyline 25 mg once daily in the evening for ten days, NRS scores were reassessed and the second measurements of these cytokines serum level were done.

Results : Twenty three subjects, 5 male and 18 female participated in this study. There was a significant difference ( $p=0.001$ ) between baseline NRS score ( $4.52 \pm 1.78$ ) with NRS score after amitriptyline administration ( $1.87 \pm 1.10$ ). No significant difference ( $p=0.051$ ) was found between baseline TNF- $\alpha$  ( $2.15 \pm 0.98$  pg/dl) with TNF- $\alpha$  level after treatment ( $1.89 \pm 0.86$  pg/dl). There was no significant difference between baseline and after 10-day amitriptyline dosage for IL-1 serum level ( $0.24 \pm 0.26$  pg/dl vs  $0.25 \pm 0.22$  pg/dl,  $p=0.954$ ) nor IL-6 serum level ( $1.84 \pm 1.36$  pg/dl vs  $2.01 \pm 1.76$  pg/dl,  $p=0.687$ ). There was a very weak negative ( $R=-0.178$ ) non significant correlation ( $p=0.415$ ) between NRS score and TNF- $\alpha$  serum level. In these subjects, we found a very weak negative ( $R=-0.111$ ) non significant correlation ( $p=0.615$ ) between NRS score and IL-1 serum level. NRS score and IL-6 serum level had a weak ( $R=-0.364$ ) non significant negative correlation ( $p=0.088$ )

Conclusions : Amitriptyline decreased serum level of TNF- $\alpha$  but not statistically significant.

Amitriptyline had no effect on IL-1 nor IL-6 serum levels. Amitriptyline lowered pain intensity based on NRS score ( $p=0.001$ ). NRS score and TNF- $\alpha$  serum level had a very weak

and non significant negative correlation. NRS score and IL-1 serum level had a very weak and non significant negative correlation, while NRS score and IL-6 serum level had a weak and non significant negative correlation.

**Index Terms-** amitriptyline, chronic tension-type headache, IL-1, IL-6, TNF- $\alpha$

## I. INTRODUCTION

Tension-type headache (TTH) is the most common form of primary headache.. Chronic tension-type headache (CTTH) differs from the episodic forms not only in frequency but also with respect to pathophysiology, lack of effect to most treatment strategies, more medication overuse, more disability, and higher personal and socioeconomic costs<sup>1</sup>. Globally, the percentages of the adult population with an active headache disorder are 46% headache in general, 11% migraine, 42% TTH and 3% chronic daily headache<sup>2</sup>.

A number of studies also have examined the levels of cytokines in the blood of headache patients, generally migraine. Bo *et al*, studied the level of cytokines in cerebrospinal fluid (CSF) in headache patients and found elevated levels of IL-1, TGF- $\beta$ 1 (*transforming growth factor- $\beta$ 1*), and MCP-1 (*monocyte chemoattractant protein-1*) in episodic tension-type headache (ETTH) and migraine compared to controls, and there were significant differences in MCP-1 between cervicogenic headache and migraine without aura<sup>3</sup>. Kocer found an increasing level of IL-6 in patients with ETTH and CTTH compared to controls. Therefore, they believe that IL-6 is involved in the induction of pain or inflammatory mechanisms in TTH<sup>4</sup>. Research by Backonja also found an elevated receptor levels of TNF in CSF and blood, elevated levels of IL-1 $\beta$  in CSF that was associated with pain intensity, whereas IL-10 was inversely correlated with pain symptoms<sup>5</sup>. Serum levels of IL-1 $\beta$  were significantly elevated in CTTH patients relative to healthy controls, while IL-18 levels were significantly elevated in men with CTTH, in a study by Vedova *et al*<sup>6</sup>.

The role of psychological condition in headache has been studied extensively. Chen *et al* found that anxiety-neurotic and depression correlate with CTTH<sup>7</sup>. Özdemir *et al* found that patients with migraine and TTH had maladaptive coping responses and more neurotic personality features and these



factors play significant role in the development of headaches and their severity<sup>8</sup>

Antidepressant is one of most commonly used drugs in CTTH management. Amitriptyline was proven better than placebo in many clinical trials<sup>9,10</sup>. Amitriptyline is frequently a first choice for prophylaxis treatment in CTTH despite of its adverse effects<sup>11</sup>. Amitriptyline is also effective for painful diabetic neuropathy<sup>12</sup>. Tricyclic antidepressants, including amitriptyline, are effective in chronic pain management in systematic review by the WorkSafeBC Evidence-Based Practice Group (EBPG)<sup>13</sup>. In persistent pain in the arms due to overuse, low dose amitriptyline increased the arms function, although did not lower pain intensity significantly<sup>14</sup>.

Prior studies have found a positive relationship between the number of cytokines with some types of headache. Unfortunately, most measurements of cytokine levels were performed in the CSF, make it relatively difficult for routine examination in daily practice. The purpose of this study is to measure the serum levels of TNF- $\alpha$ , IL-1, IL-6 in CTTH patients before and after given amitriptyline and its correlation with pain severity.

## II. METHODS

This research was done at the Adam Malik Hospital and Bukit Barisan Army Hospital Medan, Indonesia from January 2013 - June 2014 and approved by the Ethics Committee for Health Research School of Medicine in University of Sumatera Utara. The subjects were recruited consecutively from study population. Diagnosis of CTTH was made based on the diagnostic criteria as stated in the ICH X. NRS score were taken from all subjects at

baseline as well as blood for TNF- $\alpha$ , IL-1 and IL-6 serum level measurement. Each subject was given amitriptyline 25 mg once daily in the evening to minimize the side effect for 10 consecutive days. The day after the last dosage, all subject were asked to score their pain severity at that time by using NRS. The second blood samples were taken for the second TNF- $\alpha$ , IL-1 and IL-6 serum level measurement. T-paired test with the level of significancy  $p < 0.5$  was performed to analyze differences between NRS score, TNF- $\alpha$ , IL-1 and IL-6 serum level before and after amitriptyline.

## III. RESULTS

At the beginning, there were 30 patients with CTTH met the criteria of this study. Seven of them were excluded from the study, 4 subjects because they had never come for blood sampling, and 3 subjects because did not complete the study protocol. Data from 23 subjects who followed the whole procedure were analyzed further. Twenty three CTTH patients participated in this study, 5 men (21.7%) and 18 women (78.3%).

There was a significant difference ( $p=0.001$ ) between baseline NRS score ( $4.52 \pm 1.78$ ) with NRS score after amitriptyline administration ( $1.87 \pm 1.10$ ). No significant difference ( $p=0.051$ ) was found between baseline TNF- $\alpha$  ( $2.15 \pm 0.98$  pg/dl) with TNF- $\alpha$  level after treatment ( $1.89 \pm 0.86$  pg/dl). There is also no significant difference was found between baseline and after 10-day amitriptyline administration for IL-1 serum ( $0.24 \pm 0.26$  pg/dl vs  $0.25 \pm 0.22$  pg/dl,  $p=0.954$ ) and IL-6 serum ( $1.84 \pm 1.36$  pg/dl vs  $2.01 \pm 1.76$  pg/dl,  $p=0.687$ ) (Table 1).

**Table 1. NRS score, TNF- $\alpha$ , IL-1 and IL-6 serum level before and after amitriptyline administration**

Variable	Amitriptyline		<i>p</i> *
	Before (n ; $\bar{x} \pm SD$ )	After (n ; $\bar{x} \pm SD$ )	
NRS	23 ; $4.52 \pm 1.78$	23 ; $1.87 \pm 1.10$	0.001 **
TNF- $\alpha$	23 ; $2.15 \pm 0.98$ pg/dl	23 ; $1.89 \pm 0.86$ pg/dl	0.051
IL-1	23 ; $0.24 \pm 0.26$ pg/dl	23 ; $0.25 \pm 0.22$ pg/dl	0.954
IL-6	23 ; $1.84 \pm 1.36$ pg/dl	23 ; $2.01 \pm 1.76$ pg/dl	0.687

**Table 2. Correlation between NRS score and TNF- $\alpha$ , kadar IL-1 and kadar IL-6 serum level after amitriptyline administration**

NRS amitriptyline administration	after			
		TNF- $\alpha$	IL-1	IL-6
	R	-0.178	- 0.111	- 0.364
	<i>P</i>	0.415	0.615	0.088
	N	23	23	23

After amitriptyline administration, the NRS score showed very weak negative and non-significant correlations with the serum level of TNF-  $\alpha$  ( $R = -0.178$  ;  $p = 0.415$ ), IL-1 ( $R = -0.111$  ;  $p = 0.615$ ), and IL-6 ( $R = -0.364$  ;  $p = 0.088$ ) (Table 2).

## IV. DISCUSSIONS

At baseline, the mean of the NRS score was  $4.52 \pm 1.78$  and became  $1.87 \pm 1.10$  after amitriptyline administration. There was

a significant decrement of the NRS score with  $p = 0.001$ . This fact suggests that amitriptyline is effective to lower the pain intensity in CTTH patients. Amitriptyline works by inhibiting the serotonin and norepinefrin re-uptake by pre-synaptic cells (serotonin/norepinefrin re-uptake inhibitor). The effect is strong

on serotonin transporters and moderate on norepinephrine transporters. Aside from that, amitriptyline also works as receptor antagonist toward 5-HT<sub>2</sub>, 5-HT<sub>3</sub>, 5-HT<sub>6</sub>, 5-HT<sub>7</sub>,  $\alpha$ <sub>1</sub>-adrenergic, H<sub>1</sub>, H<sub>2</sub>, H<sub>4</sub>, and mACh receptors, and receptor agonist toward  $\alpha$ <sub>1</sub> receptor. Amitriptyline can also block sodium, potassium, and calcium channels<sup>15,16</sup>. Various biological mechanisms of amitriptyline as stated above, have contributed to decrease pain intensity from various medical conditions, including CTTH.

Prior to amitriptyline administration, the mean of TNF- $\alpha$  serum level was  $2.15 \pm 0.98$  pg/dl and became  $1.89 \pm 0.86$  pg/dl after administration. There was a non-significant decrement of the mean of TNF- $\alpha$  serum level ( $p=0.051$ ). This data suggests that TNF- $\alpha$  serum level had no correlation with decreasing pain intensity after amitriptyline administration in CTTH patients, differs from previous study. A study by Bo *et al* in 2008, showed significant differences between the CSF level of IL-1 $\alpha$ , TGF- $\beta$ <sub>1</sub> and MCP-1 in TTH and migraine patients when compared to the control group<sup>3</sup>. The non-significant result of TNF- $\alpha$  on this study is in accordance by several previous studies. Tanure *et al*. found no significant difference in the level of TNF- $\alpha$ , sTNFR1 and sTNFR2 during migraine attack and headache free period<sup>17</sup>. The cytokine was only increased slightly if compared to other severe neurological diseases. This increment was considered as a slight response of cytokine toward headache<sup>16</sup>. A study by Rozen *et al* found an increment of TNF- $\alpha$  in LCS of NDPH and migraine patients. But the increment was not found in serum<sup>18</sup>. TNF- $\alpha$  is the primary pro-inflammatory cytokine for brain infection diseases. In normal circumstances, the production is little. In infection condition, where there is a strong stimulation by microorganisms, the production will greatly increase so that it can be detected in blood with a quite significant level<sup>19</sup>. The non-significant finding in this study maybe due to measurement of TNF- $\alpha$  was performed in the serum where more confounding variables found compare to CSF. The very low serum level of TNF- $\alpha$  found in this study was probably indicated that in CTTH patients, only very small amount of TNF- $\alpha$  produced, in contrast with during brain infection.

There was a contradictory of significance in the result between NRS score and TNF- $\alpha$  serum level, before and after amitriptyline administration. With  $p = 0.001$ , it means that amitriptyline effectively reduced pain intensity. On the other side,  $p = 0.051$  after amitriptyline administration, suggest that TNF- $\alpha$  level was not significantly decreased as a result of amitriptyline administration. This fact suggests that pain intensity decrement due to amitriptyline administration, was not through TNF- $\alpha$  decrement mechanism. Regarding pain, there were still many biological mechanisms of amitriptyline, which were still not fully understood<sup>15</sup>. Many *in vitro* studies regarding effect of TNF- $\alpha$  on CNS has been performed, with still ambiguous conclusion<sup>20</sup>. Before amitriptyline administration, the mean level of IL-1 was  $0,24 \pm 0,26$  and it became  $0,25 \pm 0,22$  after administration ( $p=0.954$ ). This fact showed that IL-1 serum level did not significantly decrease pain intensity as a result of amitriptyline administration in chronic TTH patients. Together, IL-1 and IL-6 causes trigeminal nociceptor sensitization and play an important role in migraine pathogenesis by reducing sensitivity threshold toward other inflammatory stimulus<sup>21</sup>. As strong mediators for fever, pain, and inflammation, IL-1 and TNF- $\alpha$  function via hypothalamic induction<sup>19, 22</sup>. A research by Bo *et al*, found an

increment of cytokine IL-1, TGF- $\beta$ <sub>1</sub> and MCP-1 level in patient's LCS who had episodic TTH and migraine<sup>3</sup>. The non-significant result on IL-1 level in this research was in accordance with previous studies. In normal circumstances, the IL-1 production is very small. In infection condition, where there is a strong stimulation by micro organisms, the production will greatly elevated so that it can be detected in blood with a quite significant level<sup>19</sup>. The small quantity of IL-1 in this study was caused by TTH not being a brain infection.

There was contradictory of significance in the result between NRS score and IL-1 serum level, before and after amitriptyline administration. With  $p = 0.001$ , it means that amitriptyline effectively reduced pain intensity. On the other side,  $p = 0.954$  after amitriptyline administration, suggests that IL-1 level was not significantly different as a result of amitriptyline administration. This fact suggests that pain intensity decrement due to amitriptyline administration, was not through IL-1 decrement mechanism. Regarding pain, there were still many biological mechanisms of amitriptyline, which were still not fully understood<sup>15</sup>. The correlation between IL-1 and amitriptyline in reducing pain intensity is still unclear.

Before drug administration, the level of IL-6 =  $1,84 \pm 1,36$  and after administration it became  $2,01 \pm 1,76$  with no significant difference between them ( $p=0.687$ ). This fact showed that IL-1 serum level did not significantly decrease pain intensity as a result of amitriptyline administration in chronic TTH. Interleukin-6 function as pro and anti inflammation, secreted by T-cell and acts as initial response toward infection and trauma. This substance can penetrate blood-brain barrier and initiates PGE<sub>2</sub> in hypothalamus, thus elevating body temperature. Whenever infection is occurred, production of IL-6 will increase<sup>23</sup>. Systemic effect of IL-1 will cause induction of fever, acute phase protein plasma synthesis by liver, and direct or directly stimulate production of IL-6, and production of neutrophil and platelet of bone marrow<sup>21</sup>. In migraineurs, it has been suggested that IL-6 level increase in the attack phase. A study by Yan *et al* showed that IL-6 strengthen excitability of duramater afferent fiber so that sensitization which contributed toward pathophysiology migraine headache occurred<sup>24</sup>.

From statistical analysis there was non-significant difference of IL-6 level, with  $p = 0.687$ , after amitriptyline administration. The non-significant result of IL-6 in this study was supported by previous study results. The same as TNF- $\alpha$  and IL-1, IL-6 is very responsive toward infection<sup>23</sup>. Regarding pain in animal experiment, IL-6 can stimulate trigeminal ganglion cell to synthesize COX-2 and PGE<sub>2</sub>, which will release CGRP that causes pain<sup>25</sup>. Bo *et al* did not reveal any significant difference in CSF level of several pro inflammatory cytokines in TTH, migraine, and cervicogenic headache<sup>3</sup>. But, IL-6 pain-related detection in those several studies were obtained through LCS, not serum.

There was contradictory of the result between NRS score and IL-6 serum level, before and after amitriptyline administration. With  $p = 0.001$ , it means that amitriptyline effectively reduced pain intensity. On the other side,  $p = 0.687$  after amitriptyline administration, suggest that IL-6 level was not significantly different as a result of amitriptyline administration. Regarding pain, there were still many biological mechanisms of amitriptyline, which were still not fully understood<sup>15</sup>. This fact

suggest that pain intensity decrement due to amitriptyline administration, was not through IL-6 decrement mechanism.

## V. CONCLUSIONS

In amitriptyline group, there was a reduction of the mean of TNF- $\alpha$  serum level, from  $2,15 \pm 0,98$  pg/ml (before administration) to  $1,89 \pm 0,86$  pg/ml (after administration), but the difference was not significant ( $p=0.051$ ). As for IL-1 and IL-6 serum level, there was also non-significant difference between before and after administration ( $p=0.954$  and  $p=0.687$  respectively).

In this group, there was statistically significant decrement of pain intensity based on the mean of NRS score ( $p=0.001$ ), from  $4,52 \pm 1,78$  (before) to  $1,87 \pm 1,10$  (after). After taking amitriptyline, TNF- $\alpha$  serum level had a very weak negative correlation ( $R=-0.178$ ) and non-significant ( $p=0.415$ ) with pain intensity. There was a very weak, non-significant negative correlation ( $R=-0.111$ ;  $p=0.415$ ) between pain intensity and IL-1 serum level and a weak, non-significant correlation ( $R=-0.364$ ;  $p=0.088$ ) between pain intensity and IL-6 serum level.

## ACKNOWLEDGMENT

Authors acknowledge the immense help receive from the scholars whose articles are cited and included in references of this manuscript. The authors are also grateful to authors/editors/publishers of all those articles, journals and books from where the literature for this article has been reviewed and discussed.

## REFERENCES

- [1] Bendtsen L., Jensen R. Tension-Type Headache. *Neurol Clin.* 2009 ;27: 525–535.
- [2] Stovner L.J., Hagen K., Jensen R., Katsavara Z., Lipton R.B., Scher A., et.al. The global burden of headache: a documentation of headache prevalence and disability worldwide. *Cephalalgia* 2007; 27:193–210.
- [3] Bo, S.H., Davidsen, E.M., Gulbrandsen, P., et.al. Cerebrospinal fluid cytokine levels in migraine, tension-type headache and cervicogenic headache. *Cephalalgia.* 2008. 29(3): 365-372.
- [4] Koçer A., Memişoğulları R., Domaç F.M., İlhan A., Koçer E., Okuyucu S. et al. IL-6 levels in migraine patients receiving topiramate. *Pain Pract.* 2010;9: 375–379.
- [5] Backonja M.J., Coe C.L., Muller D.A., Schell K. Altered cytokine levels in the blood and cerebrospinal fluid of chronic pain patients. *Journal of Neuroimmunology.* 2008;195(1-2):157-163.
- [6] Vedova C.D., Cathcart S., Dohnalek A., Lee V., Hutchinson M.R., Immink M.A., et.al. Peripheral interleukin-1 $\beta$  levels are elevated in chronic tension-type headache patients. *Pain Res Manag.* 2013;18:301-306.
- [7] Chen Y., Smith DH. In-vitro approaches for studying blastinduced traumatic brain injury. *J Neurotrauma.* 2012;26:1-16.
- [8] Özdemir O., Aykan F., Özdemir P.G. Coping Strategies and Personality Traits in Women Patients with Migraine and Tension Type Headache. *Journal of Mood Disorders.* 2014;4(2):59-65.
- [9] Fernández-de-las-Peñas C., Schoenen J. Chronic tension-type headache: What is new? *Curr Opin Neurol.* 2009; 22:254-261.
- [10] Tfelt-Hansen P. Headache. In: Stannard C., Kalso E., Ballantyne J. eds. : Evidence-Based Chronic Pain Management. Sussex : Wiley-Blackwell. 2010. pp.279-291.

- [11] Bendtsen L., Evers S. Linde M., Mitsikostas D.D., Sandrini G., Schoenen J. EFNS guideline on the treatment of tension-type headache – Report of an EFNS task force. *European Journal of Neurology.*2010; 17: 1318–1325.
- [12] Bril V., England J.D., Franklin G.M., Backonja M., Cohen J.A., Del Toro D.R., et.al. Evidence-based guideline : Treatment of painful diabetic neuropathy-report of the american association of neuromuscular and electrodiagnostic medicine, the american academy of neurology, and the american academy of physical medicine & rehabilitation. *Muscle&Nerve.* 2011;43(6):910-917.
- [13] Noertjojo K., Martin C., Dunn C. Evidence-based treatment of chronic pain. *BC Medical Journal.* 2010; 52(10): 515-516.
- [14] Goldman R.H., Stason W.B., Park S.K., Kim R., Mudgal S., Davis R.B., et.al. Low-dose amitriptyline for treatment of persistent arm pain due to repetitive use. *Pain.* 2010;149(1):117-123.
- [15] Punke M.A., Friederich P. Amitriptyline is a potent blocker of human Kv1.1 and Kv7.2/7.3 channels". *Anesthesia and Analgesia.* 2007;104 (5): 1256–1264.
- [16] Tatsumi M., Groshan K., Blakely R.D., Richelson, E. Pharmacological profile of antidepressants and related compounds at human monoamine transporters. *European Journal of Pharmacology.* 1997;340 (2–3): 249–258.
- [17] Tanure M.T.A., Gomez R.S., Hurtado R.C.L., Teixeira A.L., Domingues R.B. Increased serum levels of brain-derived neurotrophic factorduring migraine attacks: a pilot study. *J Headache Pain.* 2010;11:427–430.
- [18] Rozen D. Treatment of tension-type headache with botox: a review of the literature. *Mt. Sinai J Med.* 2010; 73: 493-98
- [19] Abbas A.K., Lichtman A.H., Pillai S. *Cellular and Molecular Immunology.* 6th ed. 2007. Saunders Elsevier.
- [20] Quan N., Herkenham M. Connecting cytokines and brain: A review of current issues. *Histol Histopatho.*2002 ;17: 273-288
- [21] Durham Z.L., Durham P.L. Interleukins IL-1B and IL-5 Cause Sensitization of Trigeminal Ganglion Neurons Leading to Changes in the Ganglion and Trigeminal Nucleus Caudalis Implications for Understanding their Role in Migraine Pathology. National Headache Foundation's 7th Headache Research Summit. 2009.
- [22] Contassot E., Beer H.D., French L.E. Interleukin-1, Inflammasomes, autoinflammation and the skin. *Swiss Med Wkly.* 2012;142:w13590
- [23] D'Elia R.V., Harrison K., Oyston P.C., Lukaszewski R.A. Clark G.C. Targetting the "Cytokine Storm" for Therapeutic Benefit. *Clinical and Vaccine Immunology.*2013; 20(3):319-327
- [24] Yan J., Melemedjian O.K., Price T.J., Dussion G. Sensitization of dural afferents underlies migraine-related behavior following meningeal application of interleukin-6 (IL-6). *Molecular Pain.*2012; 8(6) : 1-9.
- [25] Neeb L., Hellen P., Boehnke C., Hoffmann J., Schuh-Hofer S., Dirnagl U. et al. IL-1b Stimulates COX-2 Dependent PGE2 Synthesis and CGRP Release in Rat Trigeminal Ganglia Cells. *PLoS ONE* 6(3). 2011: e17360. doi:10.1371/journal.pone.0017360

## AUTHORS

**First Author** – Aldy Safruddin Rambe, Neurologist, Department of Neurology University of Sumatera Utara, School of Medicine, Medan Indonesia, Email : aldysr02@yahoo.com  
**Second Author** – Hasan Sjahrir, Neurologist, Department of Neurology University of Sumatera Utara, School of Medicine, Medan Indonesia, Email : hsjahrir@yahoo.com  
**Third Author** – Moh. Hasan Machfoed, Neurologist, Department of Neurology Airlangga University, School of Medicine, Surabaya Indonesia, Email : mh.machfoed@gmail.com

**Correspondence Author** – Aldy Safruddin Rambe, Perumahan Taman Setia Budi Indah II Blok VI No. 5 Medan Indonesia 20132, Phone number : +6261-8218396, Mobile phone : +628126022270, Email address : aldysr02@yahoo.com

# Hybrid biofunctional nanostructures as stimuli-responsive

Darsana.M.D

\* MTech polymer, MBA, Lecturer, Polymer Technology, Kottayam

**Abstract-** A novel active biocatalytic reaction system is proposed by covalently immobilizing porcine pancreas trypsin within the thermore-sponsive polymer shell of superparamagnetic Fe<sub>3</sub>O<sub>4</sub> nanoparticles.

Active ester-functional nanocarriers suitable for the immobilization of amino functional targets are obtained in a single polymerization step by grafting-from copolymerization of an active ester monomer from superparamagnetic cores. The comonomer, oligo(ethylene glycol) methyl ether methacrylate, has excellent water solubility at room temperature, biocompatibility, and a tunable lower critical solution temperature (LCST) in water. The phase separation can alternatively be initiated by magnetic heating caused by magnetic losses in ac magnetic fields.

The immobilization of porcine pancreas trypsin to the core-shell nanoparticles results in highly active, nanoparticulate biocatalysts that can easily be separated magnetically. The enzymatic activity of the obtained biocatalyst system can be influenced by outer stimuli, such as temperature and external magnetic fields, by utilizing the LCST of the copolymer shell.

**Index Terms-** biocatalysis; biolabelling; core-shell nanoparticles; immobilization matrix; thermoflocculation

## I. INTRODUCTION

The use of an external stimulus for the activation of (bio)chemical reaction processes can be a valuable tool in fundamental research and in applications such as reaction kits or lab-on-a-chip systems, as it allows for on-demand triggering of an active catalyst, and ideally can be limited, if necessary, to a geometrical confinement. By controlling the catalytic activity of a particulate carrier by a switchable stimulus, the reaction rate of the catalysed process can be significantly accelerated or slowed down. One promising stimulus in this respect is the change of temperature. Polymeric materials show a wide range of thermoresponsive effects that can be explored for a discontinuous change of diffusion or reaction rate [1-3]. The temperature increase can for example be restricted locally by using near infrared (NIR) irradiation [4]. Other systems use a photodynamic process to force a medical effect by the photochemical drug release during light irradiation [5]. By combining thermoresponsive polymers with magnetic nanoparticles, hybrid materials become accessible that can be manipulated by two different stimuli, temperature and magnetic fields. Such dual responsive materials are of interest for a variety of applications ranging from magnetic separation or drug release systems to sensors and actuation [6-13]. We, and other groups, have

demonstrated that magnetite nanoparticles decorated with a stabilizing shell composed of LCST or upper critical solution temperature (UCST) polymers lead to nanocomposites that show thermally inducible flocculation behavior in the carrier medium [14-21]. The particles agglomerate at a critical temperature resulting in an enhanced magnetic response. Thus the agglomerated particles can be separated easily by low magnetic field gradients, and facilitate, for instance, the separation process in purification applications of biomolecules.

Reversible thermoflocculation of magnetic colloids by encapsulation with thermoresponsive polymers has been proposed based on thermoresponsive polymers such as poly(N-isopropylamide) (PNiPAAm) [15,21-24] and (oligoethylene glycol) methacrylate copolymers (POEGMA) [25], which both show an LCST type behavior, and on glycinamide copolymers with an UCST behavior at around 10 °C [20,26]. The formation of a polymer brush on the surface of single nanoparticles has proved to be a valuable tool for the design of single-cored hybrid structures with tailored dispersion behavior [17-19,21,27-30].

Magnetic polymer brushes with thermoflocculation behavior have been reported for organic solvents by our group [17-19]. Lately, hydrophilic brush shells have been described [31-34], prepared either by surface-initiated polymerization or by a "grafting to" approach of tailored copolymers from oligo(ethylene glycol) methacrylates with adjustable and narrow flocculation temperature and low unspecific adsorption [25,35]. The ability of magnetic nanoparticles to show considerable heat dissipation due to relaxation processes is recently employed in the combination with thermoresponsive polymers [34,36-39]. In ac magnetic fields in the kHz range, the nanoparticles transform magnetic energy to heat energy due to relaxation processes and hysteresis losses [40-42].

Here, we report the investigation of a biocatalytically active carrier system that can be tuned by temperature or external magnetic fields. The hybrid nanostructures are obtained by the combination of magnetic nanoparticle cores with a thermoresponsive poly[oligo(ethylene glycol) methyl ether methacrylate] copolymer shell [17,18,33,34] and covalently attached protease trypsin as the biocatalytically active species. A reversible shell collapse at elevated temperatures is made responsible for significantly enhanced protease activity.

## II. RESULTS AND DISCUSSION

The target of the present study is the development of magnetic nanocarriers with tunable enzymatic activity. For the realization of such a system, we use several components, each performing a specific function. The iron oxide magnetic core



allows positioning and heat generation, owing to its behavior in static and dynamic magnetic fields. The polymer shell is the anchor for covalent attachment of the enzyme, and allows the introduction of thermoresponsive behavior. At the same time, it improves biocompatibility and stabilization against agglomeration. Finally, the immobilization of trypsin as a serine protease introduces biocatalytic activity. These components result in hybrid nanostructures, which serve as a recoverable reaction system that can be activated reversibly by external magnetic fields, by using the thermal energy developed by magnetic heating of the superparamagnetic cores in combination with the thermoresponse of the shell.

These multifunctional hybrid particles are formed by surface initiated copolymerization of oligo(ethylene glycol) methyl ether methacrylates (labeled as MEMA (M), MEEMA (M') and OEGMA (O)) with N-succinimidyl methacrylate (SIMA (S), Figure 1) as an active ester-functional monomer in DMSO by using surface-modified Fe<sub>3</sub>O<sub>4</sub> nanoparticles as macroinitiators (Scheme 1). Subsequently, subunits carrying primary amine groups, such as proteins or enzymes, can be immobilized via the active ester pendant groups of the brush-type shell.

#### Synthesis of functional core-shell nanostructures

In the first step, Fe<sub>3</sub>O<sub>4</sub> nanoparticles are prepared by alkaline precipitation based on a method of Cabuil and Massart [43] and surface-functionalized with (p-chloromethyl)phenyltrimethoxysilane (CTS) [44] in order to introduce benzylic chlorine groups for subsequent initiation of atom transfer radical polymerization (ATRP). Oligo(ethylene glycol) methyl ether methacrylates with different length of the hydrophilic side chain are used as the main monomer to generate a hydrophilic polymer shell with tunable critical solution behavior in water. By proper choice of the copolymer composition, the thermoflocculation temperature of the core-shell particles can be adjusted [34,35].

The biocompatibility of poly(ethylene glycol) derivatives is helpful to obtain nanoparticles acceptable for use in *in vitro* biological systems.

The direct introduction of carboxy functions to the polymer shell by surface-initiated ATRP involving (meth)acrylic acid is hindered by catalyst poisoning, resulting in a loss of reaction control. To overcome this, the protection of the carboxy group is useful [45], and in our approach, we employed succinimidyl methacrylate (SIMA) as a methacrylic acid derivative suitable for ATRP [46-48]. We have initially investigated the copolymerization behavior of the two monomers in model copolymerization experiments in solution, to ensure proper incorporation of the functional groups and stability of the active ester functionality under the polymerization conditions [33].

The catalytic system employed in the synthesis is based on copper(I) bromide and 2,2'-bipyridine in a DMSO solution. After 24 h of stirring at ambient temperature, viscous, deep brown magnetic dispersions are obtained. The success of the surface-initiated ATRP is qualitatively analyzed by transmission electron microscopy (TEM) and ATR-IR spectroscopy [33] on carefully washed and dried particles. TEM images (Figure 2) of the obtained nanoparticles demonstrate strongly contrasting Fe<sub>3</sub>O<sub>4</sub> cores surrounded by less contrasting polymer shells. The nearly

spherical nanoparticles are separately covered with a polymer layer of an average thickness of 3 nm, independent of the core size.

ATR-IR spectra (Figure 3b) of the dry Fe<sub>3</sub>O<sub>4</sub>@P(O x M y S z) nanoparticles feature signals relating to the vibrational absorption of polymeric methyl and methylene groups ( $\nu = 2800 \text{ cm}^{-1}$ – $3050 \text{ cm}^{-1}$ ), carbonyl double bond ( $\nu = 1722 \text{ cm}^{-1}$ ), C–O deformation ( $\nu = 1099 \text{ cm}^{-1}$ ) and N–O deformation ( $\nu = 1025 \text{ cm}^{-1}$ ), which clearly reveals the presence of P(OEGMA-co-SIMA). The three distinct peaks at  $\nu = 1807 \text{ cm}^{-1}$ ,  $1778 \text{ cm}^{-1}$  and  $1722 \text{ cm}^{-1}$  are characteristic of the vibrational absorption of the three carbonyl double bonds of the SIMA function, indicating that the succinimidyl ester is still existent and is neither hydrolysed nor deactivated [33]. The composition of the obtained hybrid materials is determined from mass loss between 150 °C and 480 °C in thermogravimetric analysis (TGA) (Table 1).

The hydrodynamic diameter of the core-shell nano-objects in aqueous dispersion can be detected by dynamic light scattering (DLS). A significant increase of the hydrodynamic diameter can be observed (Table 1), compared to electrostatic stabilized particles, and to CTS functionalized particles with a number average hydrodynamic diameter  $d_{h,n}$  of 14 nm and 21 nm, respectively.

#### Hybrid particle characteristics

The magnetic properties of the nanoparticles at different points within the synthesis were investigated via vibrating sample magnetometry (VSM). In Figure 4a the magnetization curves of electrostatically stabilized nanoparticles Fe<sub>3</sub>O<sub>4</sub>@CA, initiator functionalized nanoparticles Fe<sub>3</sub>O<sub>4</sub>@CPS and magnetic polymer brushes Fe<sub>3</sub>O<sub>4</sub>@P(O100) are shown. Obviously, the graphs are almost perfectly matched after normalization by the saturation magnetization  $M_s$ , demonstrating that the magnetization behavior of the magnetic cores does not change during the synthesis of the polymer brushes. Furthermore, it can be observed from the graphs that the particles' cores are superpara magnetic and show no hysteresis in all investigated samples. By employing Chantrell's method [49], we extract values for the core diameter between 10.2 nm and 10.7 nm from the initial slope (Table 1) [36].

As a consequence of the surface-initiated polymerization process, the polymer shells are end tethered to the particle surface in high density, as it has been previously shown by us and others [15,17]. When exposed to a suitable solvent, the polymer chains are highly solvated and protrude out from the surface in form of a polymer brush. In this state, the shell readily serves as a steric stabilizer for the particle dispersion, as the solvated brush surfaces result in a short-range repelling potential between individual particles. In contrast, when exposed to a bad solvent, the shell collapses, and particle agglomeration is observed.

In the present case, the polymer shell displays a reversible LCST behavior in water with a thermoflocculation temperature  $T_c$  that can be adjusted by the copolymer composition, as we have shown in a recent paper [34]. Thus, in aqueous media, the hybrid particles show thermoresponsive behavior [25]: while readily dispersible at low temperature, they reversibly flocculate

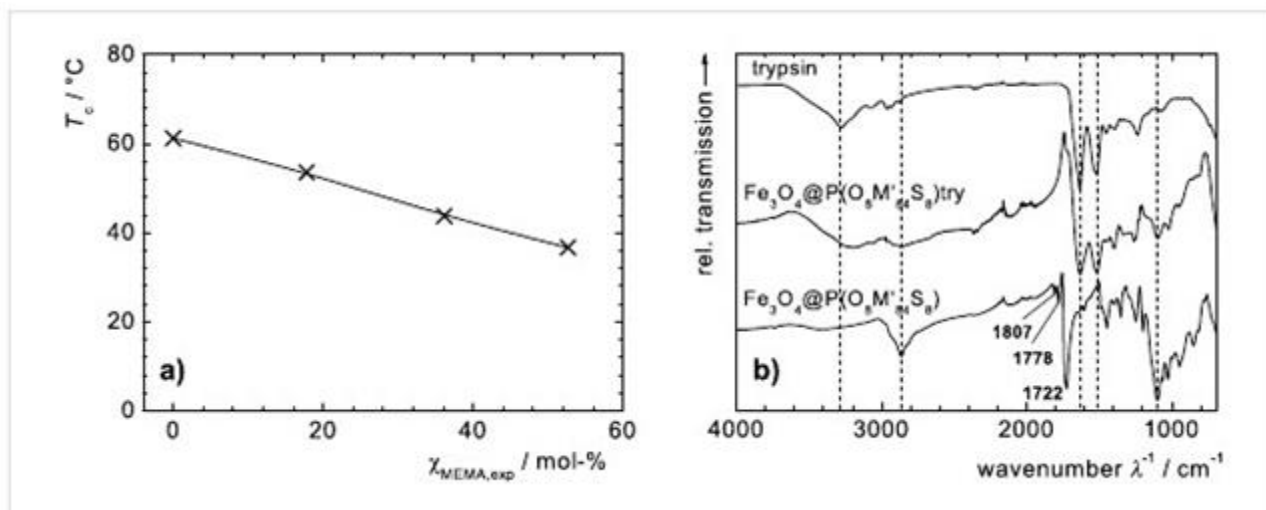
when the dispersion temperature reaches the  $T_c$  of the shell, and therefore form a separate phase.

In the agglomerated state above the LCST, simple permanent magnets with magnetic field gradients below  $50 \text{ mT}\cdot\text{cm}^{-1}$  are sufficient to separate the magnetic polymer brush particles from the carrier medium. We have shown that this behavior is of use for the easy magnetic separation of amino-functional probes and magnetically labeled biomolecules [33]. In this respect it is of interest to note, that the cloud point temperature can be adjusted by copolymerization in a wide range, including temperatures acceptable for biomolecules and biological species (Figure 3a) [34]. Furthermore, it has been shown that thermoflocculation of core-shell particles can be induced by magnetic heating of the particle cores in suitable ac magnetic fields [34,38].

**Table 1: Physical and chemical composition of investigated multifunctional core-shell nanoparticles.**

Sample <sup>a</sup>	$\mu_P$ [wt %]	$d_{h,ndc}$ [nm] [nm]	$\mu_{MF}$ [wt %]	$T_c$ [°C]
Fe <sub>3</sub> O <sub>4</sub> @P(O100)	62.9	169 10.2	2.10	61.2
Fe <sub>3</sub> O <sub>4</sub> @P(O82M18)	43.8	127 10.7	1.91	53.4
Fe <sub>3</sub> O <sub>4</sub> @P(O64M36)	62.8	171 10.5	2.48	43.7
Fe <sub>3</sub> O <sub>4</sub> @P(O47M53)	33.8	113 10.3	1.22	36.6
Fe <sub>3</sub> O <sub>4</sub> @P(O75S25)	40.4	79 12.1	2.14	59.4
Fe <sub>3</sub> O <sub>4</sub> @P(O80S20)	49.9	47 10.3	1.54	57.8
Fe <sub>3</sub> O <sub>4</sub> @P(O85S15)	41.3	73 12.0	2.33	60.8
Fe <sub>3</sub> O <sub>4</sub> @P(O90S10)	52.1	49 10.4	1.51	57.9
Fe <sub>3</sub> O <sub>4</sub> @P(O95S5)	43.9	48 10.4	1.91	—
Fe <sub>3</sub> O <sub>4</sub> @P(O8M'84S8)	39.8	75 11.3	1.56	32.3

annotation: Fe<sub>3</sub>O<sub>4</sub>@P(O<sub>w</sub>M<sub>x</sub>M'<sub>y</sub>S<sub>z</sub>) with molar fraction of w: OEGMA, x: MEMA, y: MEEMA, and z: SIMA in the polymer shell;  $\mu_P$ : mass fraction of copolymer in dry particle powder (TGA),  $d_{h,n}$ : number average hydrodynamic diameter (DLS),  $d_c$ : volume average core diameter (VSM),  $\mu_{MF}$ : mass content of Fe<sub>3</sub>O<sub>4</sub> in saturated DMSO dispersion (VSM),  $T_c$ : cloud point temperature (CPP).

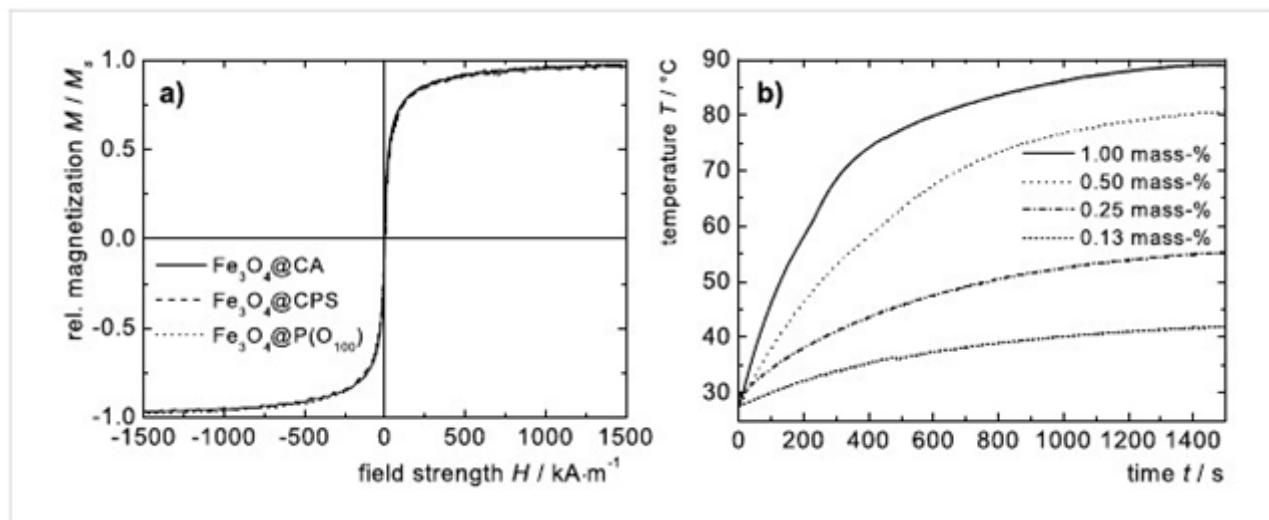


**Figure 3: a) Cloud point temperature  $T_c$  of Fe<sub>3</sub>O<sub>4</sub>@P(O<sub>x</sub>M<sub>y</sub>) in water in relation to molar fraction of MEMA  $\chi_{M,exp}$  in the polymer shell. b) ATR-IR spectra of trypsin, Fe<sub>3</sub>O<sub>4</sub>@P(O8M'84S8); and Fe<sub>3</sub>O<sub>4</sub>@P(O8M'84S8)-Try (dry powders).**

The ability of superparamagnetic nanoparticles to locally develop heat when exposed to external ac magnetic fields in the kHz range is of considerable interest to activate physical or chemical processes in the vicinity of the particles, e.g., in hyper-thermia [50,51], and for the remote operation of thermoresponsive soft actuators [39,52]. The heat development occurs due to relaxational processes (Néel and Brown) as well as hysteresis effects that results in considerable losses during the dynamic magnetic response of the materials [40,53-55].

We investigated the behavior of Fe<sub>3</sub>O<sub>4</sub>@P(O100) dispersions in an oscillating magnetic field (250 kHz,  $H = 31.5 \text{ kA}\cdot\text{m}^{-1}$ ) by recording the sample temperature with time (Figure

4b). The temperature of all samples increases within minutes to temperatures up to 80 °C depending on the FeO<sub>x</sub> content. A higher Fe<sub>3</sub>O<sub>4</sub> content leads to faster heating, and a specific heat power (SHP) =  $86.5 \text{ W}\cdot\text{g}^{-1}$  of the particle cores can be extracted from the data. The generated heat flux is strong enough to reach the cloud point temperature  $T_c$  of 61 °C in the dispersions at magnetic fractions of  $\mu(\text{Fe}_3\text{O}_4) = 0.5$  mass % and higher. In this temperature range, we observe a slight deviation from the expected logarithmic deceleration of the heating rate (Figure 4b). We attribute the deviation to the heat consumption caused by the phase transition process.



**Figure 4: a) Normalized magnetization loops of dispersions based on  $\text{Fe}_3\text{O}_4@CA$  in water (solid line),  $\text{Fe}_3\text{O}_4@CPS$  in DMSO (dashed line), and  $\text{Fe}_3\text{O}_4@P(M90C10)$  in DMSO (dotted line); b) sample temperature  $T$  vs irradiation time  $t$  for  $\text{Fe}_3\text{O}_4@P(O100)$  nanoparticle dispersions in ac magnetic fields (250 kHz,  $H = 31.5 \text{ kA}\cdot\text{m}^{-1}$ ).**

#### Enzyme immobilization and activity

The immobilization of biomacromolecules on magnetic carriers is of interest for separable biocatalytic systems. We successfully immobilized trypsin as a model enzyme on the shell of  $\text{Fe}_3\text{O}_4@P(O8M'84S8)$  nanoparticles. Particles with low SIMA functionality have been chosen to avoid particle cross-linking or agglomeration due to multiple attachment of a single protein molecule by several nano-objects. Figure 3b compares the ATR-IR spectra of trypsin-functional nanoparticles ( $\text{Fe}_3\text{O}_4@P(M8O84S8)\text{-Try}$ ) to free trypsin. In both samples, we observe similar amide signals ( $\nu = 1620, 1578 \text{ cm}^{-1}$ ), and also the NH-signal ( $\nu = 3284 \text{ cm}^{-1}$ ) of the trypsin peptide sequence is visible in both spectra. From the nitrogen content obtained by elemental analyses (EA), the amount of trypsin bound to the polymer surface of the nanoparticles is calculated to 111 mg trypsin per g particle ( $4.76 \mu\text{mol}\cdot\text{g}^{-1}$ ), compared to commercially available magnetic particles for the protein binding with reported capacities between  $1.5 \text{ mg}\cdot\text{g}^{-1}$  and  $20 \text{ mg}\cdot\text{g}^{-1}$  [33,56]. The catalytic activity of trypsin, a protease for hydrolysis of specific peptide bonds (chain scission after the amino acids arginine and lysine), is investigated by the classical BAPNA method [57] and is compared to the native protein. Trypsin catalyzed hydrolysis of benzoyl-Arg p-nitroanilide (BAPNA) results in the formation of p-nitroaniline that can be quantified by UV-vis spectroscopy at 410 nm (Scheme 2) [58].

The increase of relative absorption  $A_{410}$  is observed over time for different substrate concentrations  $c_{BAPNA}$ .  $A_{410}$  is directly correlated to the p-nitroaniline concentration, thus the reaction rate  $v = d[P]/dt$  can be obtained from the initial slopes [2]. As a control experiment the primarily  $\text{FeOx}@P(O8M'84S8)$  nanoparticle dispersion without trypsin bound to the polymer shell is also used; no increase in UV absorption over time was detected in the control experiment. In every run employing either trypsin or immobilized trypsin, a linear increase of absorption with time can be detected in UV experiments for initial stages.

To exclude possible trypsin leaching from the carriers, we continued the data collection for a couple of minutes after magnetic separation of the magnetic nanoparticles from the BAPNA solution. No further increase in adsorption was detected.

By linearly plotting the reaction rates vs the BAPNA concentration  $c_{BAPNA}$  (Cornish-Bowden plot, Figure 5a), a hyperbolic behavior is observed that can nicely be fitted by the Michaelis Menten equation. The graph trends towards the saturation rate  $v_{\text{max}}$ , and the Michaelis constant  $K_m$ , respectively; where

$$v = \frac{v_{\text{max}} \cdot c_{BAPNA}}{K_m + c_{BAPNA}} \quad (1)$$

Data linearization can be achieved by the Eadie-Hofstee method [59] (Figure 5b) by plotting  $v$  against  $v \cdot c_{BAPNA}^{-1}$ , and using the Michaelis-Menten equation in the form:

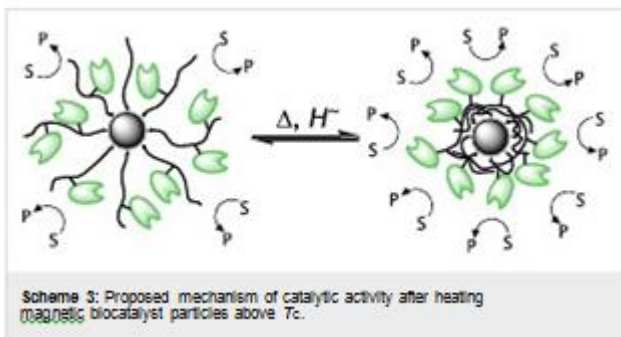
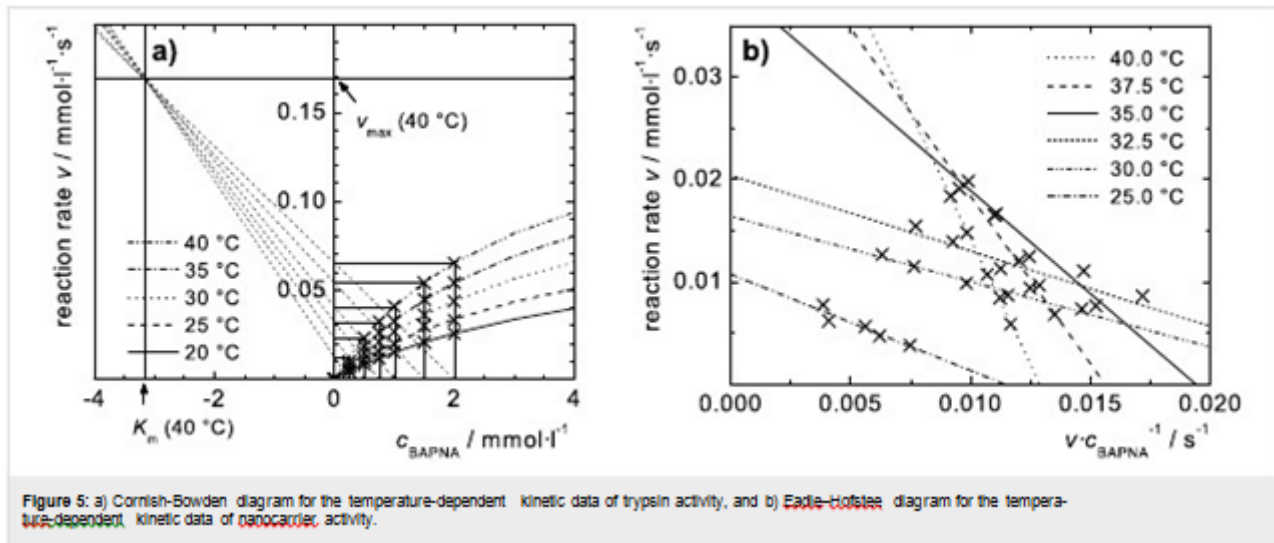
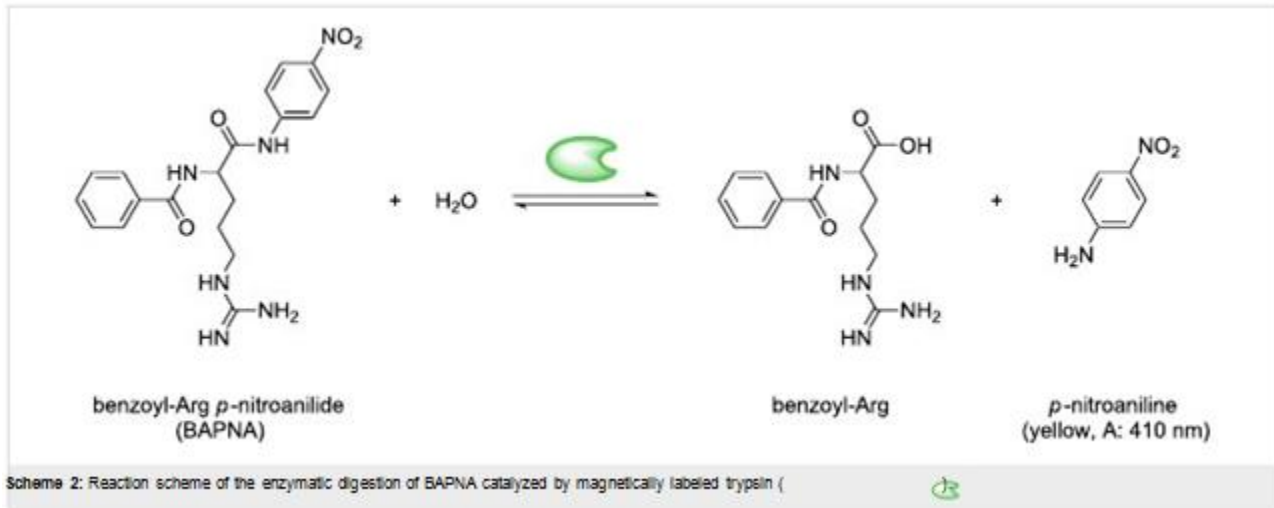
$$v = -K_m \frac{v}{c_{BAPNA}} + v_{\text{max}} \quad (2)$$

$K_m$  and  $v_{\text{max}}$  can be determined from the negative slope and the intercept of the linear plots, respectively. A discontinuous behavior can be observed in the range of the LCST temperature ( $32.3 \text{ }^{\circ}\text{C}$ , see above) for aqueous  $\text{Fe}_3\text{O}_4@P(O8M'84S8)\text{-Try}$  dispersions.

While the Michaelis constant  $K_m$  of free trypsin decreases slowly with temperature, for particle-immobilized trypsin a strong increase is observed for temperatures above the  $T_c$  of the polymer, indicating a decrease in complex stability, probably due to shell collapse or particle precipitation, or both (Figure 6b). Nevertheless, the turnover number  $k_{\text{cat}} = v_{\text{max}}/c_{\text{trypsin}}$  that is comparably low for particle-bound trypsin below  $T_c$ , indicates a

considerable acceleration of the particle- catalyzed reaction at temperatures above the  $T_c$  of the particle dispersion (Figure 6a). Probably, the shell collapse eases access to the enzyme for the substrate, considering that with a molar mass of  $23,300 \text{ g}\cdot\text{mol}^{-1}$  the molecule size of trypsin is of the same order as  $M_n$  of the

surface immobilized polymer chains (Scheme 3). In an upcoming study, the influence of diffusion and the extraction of thermodynamic parameters will give more insight to this process.



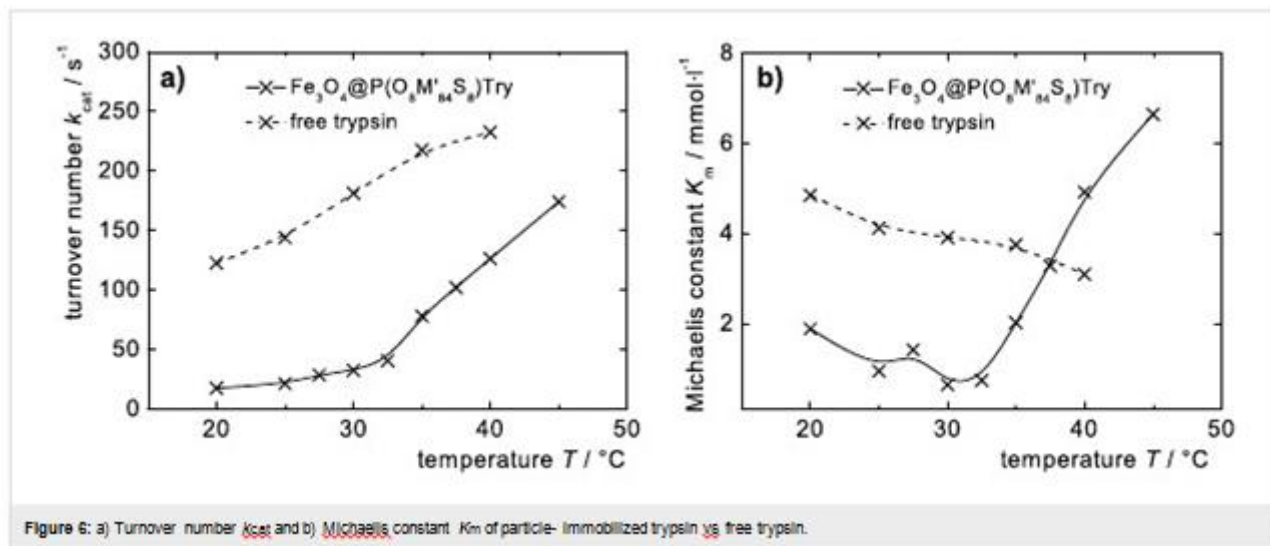
### III. CONCLUSION

In summary the presented results show that the combination of magnetic cores with a biocatalytically active, thermoresponsive polymer shell is a promising approach for nanoscopic carrier systems that allow an external reaction control and magnetic recovery of the catalyst.  $\text{Fe}_3\text{O}_4$  nanoparticles with a brush shell composed of poly(oligo(ethylene glycol) methacrylates) and functionalized with porcine pancreas trypsin show temperature tunable activity. Kinetic experiments on the catalytic activity by the BAPNA method support the reaction acceleration in particle-immobilized trypsin when the particles are heated across the transition temperature of the polymer shell, an effect that is attributed to the shell collapse. The particles can be heated by ac magnetic fields, resulting in remotely controlled



biocatalytic systems. The principle described here is applicable to the modification of other biologically or catalytically relevant groups, and will therefore open new ways for the design of

multifunctional hybrid nanostructures with different property portfolios.



#### IV. EXPERIMENTAL

Materials: Ammonium hydroxide aqueous solution (Fluka, 25%), N $\alpha$ -benzoyl-D,L-arginin-4-nitroanilide hydrochloride (BAPNA) (Sigma, 98%), benzylamine (BzA) (Janssen Chimica), 2,2'-bipyridine (bpy) (Aldrich, 99%), citric acid monohydrate (Grüssing GmbH, 99,5%), (4-(chloromethyl)phenyl)trimethoxysilane (CPS) (ABCRC, 95%), copper(I) bromide (CuBr) (Aldrich, 98%), 1-(3-dimethylaminopropyl)-3-ethylcarbodiimide hydrochloride (EDC) (ABCRC, 98%), N-hydroxy succinimide (NHS, Fluka), iron(III) chloride hexahydrate, iron(II) chloride tetrahydrate (Fluka, 98%), ninhydrin (Riedel-de-Haen), oligo(ethylene glycol) methylether methacrylate (OEGMA, Aldrich, Mn = 290 g $\cdot$ mol<sup>-1</sup>), 2-(2-methoxyethoxy)-ethyl methacrylate (MEEMA), porcine pancreas trypsin type IX-S (Aldrich), tetramethylammonium hydroxide aqueous solution (25%) were used as received without further purification. Ethanol, diethyl ether and acetone were purified by distillation before use. Dimethyl sulfoxide (DMSO; min. 99.5%, Riedel-de-Haen) was distilled under reduced pressure from calcium hydride and stored under argon and molecular sieve (3A). HEPES buffer was prepared from 11 mM HEPES (Sigma), 140 mM NaCl (Merck), 4 mM KCl (Merck), 10 mM D(+)-glucose, and dissolved in deionized water. 2-Methoxyethyl methacrylate (MEMA, Aldrich, 99%) was distilled under reduced pressure and stored under argon. Nitric acid (conc., p.a., Merck) was diluted with distilled water resulting in a 2 N solution. Succinimidyl methacrylate (SIMA) was synthesized by a method by Gatz et al [26,60].

Synthesis and stabilization of Fe<sub>3</sub>O<sub>4</sub> nanoparticles: The synthesis of magnetite nanoparticles on the gram scale was carried out by alkaline precipitation of iron(III) and iron(II) chloride following a method of Cabuil and Massart and is described in detail elsewhere [43]. For stabilization, the freshly synthesized nanoparticles were stirred with 420 mL 2 N nitric acid for 5 min. After washing with distilled water, 90 mL 0.01 N

citric acid (CA) was added to the nanoparticles and stirred for 5 min. The particles were magnetically separated from the supernatant and 15 mL of tetramethyl ammonium hydroxide aqueous solution was added to obtain 3.32 g magnetic nanoparticles Fe<sub>3</sub>O<sub>4</sub>@CA in 92 mL of a stable dispersion at pH 8–9 (yield:42.5%).

The Fe<sub>3</sub>O<sub>4</sub> content  $\mu(Fe_3O_4)$  in dispersion and the magnetic core diameter  $d_c$  were determined via VSM ( $\mu(Fe_3O_4) = 2.55$  mass%,  $d_c = 11.7$  nm). DLS:  $d_h, n = 14.3$  nm (25 °C in H<sub>2</sub>O) FT-IR (Diamond):  $\nu$  (cm<sup>-1</sup>) = 2357, 2335 (C–N), 1247 (OH), 1098 (C–O), 1080 (OH).

Surface modification of Fe<sub>3</sub>O<sub>4</sub> nanoparticles: For the immobilization of initiator sites on the particle surface of Fe<sub>3</sub>O<sub>4</sub>@CA, the dispersion was diluted with ethanol to a mass content of 1.0 g $\cdot$ l<sup>-1</sup>, and 1.80 mmol CPS per gram of Fe<sub>3</sub>O<sub>4</sub> was added. After stirring for 24 h at ambient temperature, ethanol was removed under reduced pressure at 40 °C and the particles were washed with ethanol/acetone (1:1) five times. The particles were then redispersed in DMSO, resulting in a Fe<sub>3</sub>O<sub>4</sub> content  $\mu(Fe_3O_4)$  of 6.44 mass % (VSM) in dispersion (yield: 46.4%). The magnetic core diameter  $d_c$  was measured to be 11.1 nm (VSM). The functionalization degree of CPS was determined by EA to be 0.87 mmol CTS on 1.94 g Fe<sub>3</sub>O<sub>4</sub>@CPS. FT-IR (Diamond):  $\nu$  (cm<sup>-1</sup>) = 2357, 2335 (C–N), 1241 (OH), 1115 (Si–O), 1011, 948 (Si–C).

Surface-initiated ATRP of functional polymer shells: The obtained CPS coated particles served as a macroinitiator for the following ATRP. The synthesis of Fe<sub>3</sub>O<sub>4</sub>@P(O<sub>100</sub>) is described, representatively. Therefore 6 mL of the DMSO-based particle dispersion (0.65 g Fe<sub>3</sub>O<sub>4</sub>@CPS) was mixed with 5 mL of a DMSO solution of 37.3 mg (0.26 mmol) CuBr and 101 mg (0.65 mmol) bpy. The polymerization was started by adding 5.83 mmol of the monomer (here: OEGMA). The mixture was stirred for 24 h at ambient temperature. The obtained viscous magnetic fluid was diluted with 10 ml DMSO to the final ferrofluid. The Fe<sub>3</sub>O<sub>4</sub> content  $\mu(Fe_3O_4)$  in dispersion and the magnetic core

diameter  $d_c$  were determined via VSM. The polymer content  $\chi_{Pol}$  in the dried particles was obtained from EA and TGA.

Particle transfer to water/buffer: The DMSO-based particle dispersion was added dropwise to diethyl ether (Et<sub>2</sub>O). The precipitate was washed five times with Et<sub>2</sub>O/Acetone (1:1) and was redispersed in distilled water or buffer to obtain an aqueous magnetic fluid.

Immobilization of trypsin: 30 mg trypsin was dissolved in 6 mL HEPES buffer and mixed with 6 mL of a HEPES buffer-based Fe<sub>3</sub>O<sub>4</sub>@P(O 85 S 15) particle dispersion ( $\mu(\text{FeO } x) = 0.15$  mass %). In order to allow reactivation of active ester functions that may have hydrolyzed during storage, 6 mL of 2.21  $\mu\text{M}$  EDC/NHS solution was added. The binding reaction was carried out for 6 h at ambient temperature on a shaker. The obtained trypsin functionalized particles were separated and washed carefully with water to remove any residues of free trypsin, and redispersed in HEPES buffer.

Determination of immobilized enzyme kinetics and activity: BAPNA was used as the model substrate. Four HEPES buffered BAPNA solutions with concentrations between 2.0 mM and 0.5 mM, and a 6.0  $\mu\text{M}$  trypsin solution were prepared and tempered to the desired temperature. The respective BAPNA solution was added to a cuvette and mixed with 100  $\mu\text{L}$  of FeO<sub>x</sub>@POEGMA-trypsin nanoparticle dispersion or with 50  $\mu\text{L}$  trypsin solution. The cuvette was placed into the spectrophotometer and tempered. Starting with the addition of the enzyme, the change in absorption at 410 nm was detected over a period of up to 20 min by UV-vis spectroscopy.

Analytic methods and instrumentation: ATR-IR spectra were measured on a Nicolet 6700 spectrometer. Elemental analyses were performed on a Perkin-Elmer 2400 CHN analyzer. The organic content was calculated through C content. For TGA, a Netzsch STA 449c in a He atmosphere was used with a heating rate of 10 K·min<sup>-1</sup> between 30 and 600 °C. Gel permeation chromatography (GPC) elugrams were collected on THF (300 × 8 mm 2 MZ Gel Sdplus columns, Waters 410 RI-detector) relative to polystyrene standards. NMR spectroscopy was performed on a Bruker DRX500 at 500 MHz and ambient temperature. DLS experiments and zeta potential measurements were performed on a Malvern Zetasizer Nano ZS at 25 °C. The particle size distribution was derived from a deconvolution of the measured intensity autocorrelation function of the sample by the general purpose mode (non-negative least-squares) algorithm included in the DTS software. Each experiment was performed at least three times. Cloud point photometry of aqueous particle dispersions was performed on a Tepper TP1 cloud point photometer at 1 K·min<sup>-1</sup> in HEPES buffer. From the turning point of the turbidity curves, the cloud point temperature  $T_c$  was obtained. Vibrating sample magnetization (VSM) measurements were implemented on an ADE Magnetics vibrating sample magnetometer EV7. Induction heating experiments were performed on a Hüttinger HF generator Axio 5/450T equipped with a copper inductor ( $l = 50$  mm,  $dI = 35$  mm,  $n = 5$ ), and operating at 250 kHz and at a magnetic field of 31.5 kA·m<sup>-1</sup>. The experiments were performed in a vacuum-isolated glass sample container. Different samples with varying magnetite concentrations  $\mu(\text{Fe}_3\text{O}_4)$  of Fe<sub>3</sub>O<sub>4</sub>@P(O100)- based magnetic fluid in water were exposed to the oscillating magnetic field. Via a fiber-optical sensor the fluid temperature  $T$  was measured

against time  $t$ . For UV-vis spectroscopy, a Nicolet UV 540 spectroscope, a Unicam UV 500 or a Perkin Elmer Lambda19 with a thermostat Colora NBDS was used. Differential scanning calorimetry thermograms were collected on a Mettler-Toledo DSC 822e at 5 K·min<sup>-1</sup>. TEM pictures were taken on a Hitachi H 600.

## V. ACKNOWLEDGEMENTS

Thanks to Prof. T. J. J. Müller, HHU Düsseldorf, for the use of the temperature controlled UV-vis spectrometer and Prof. H. Ritter, HHU Düsseldorf for generous support. We also thank C. Schlemmer, ALU Freiburg, for recording TEM pictures. We gratefully acknowledge DFG (Emmy Noether Program, priority program SPP 1259) and FCI (A. M. Schmidt, G. U. Marten) for financial support.

## REFERENCES

- [1] Tokarev, I.; Minko, S. *Adv. Mater.* 2009, 21, 241–247. doi:10.1002/adma.200801408
- [2] Keurentjes, J. T. F.; Kemmere, M. F.; Bruinewoud, H.; Vertommen, M. A. M. E.; Rovers, S. A.; Hoogenboom, R.; Stemkens, L. F. S.; Péters, F. L. A. M. A.; Tielen, N. J. C.; van Asseldonk, D. T. A.; Gabriel, A. F.; Joosten, E. A.; Marcus, M. A. E. *Angew. Chem., Int. Ed.* 2009, 48, 9867–9870. doi:10.1002/anie.200904172
- [3] Kawaguchi, H.; Kisara, K.; Takahashi, T.; Achiha, K.; Yasui, M.; Fujimoto, K. *Macromol. Symp.* 2000, 151, 591–598. doi:10.1002/1521-3900(200002)151:1<591::AID-MASY591>3.0.CO;2-P
- [4] Weissleder, R. *Nat. Biotechnol.* 2001, 19, 316–317. doi:10.1038/86684
- [5] Sun, Y.; Chen, Z.; Yang, X.; Huang, P.; Zhou, X.; Du, X. *Nanotechnology* 2009, 20, 135102–135110. doi:10.1088/0957-4484/20/13/135102
- [6] Pankhurst, Q. A.; Thanh, N. K. T.; Jones, S. K.; Dobson, J. J. *Phys. D: Appl. Phys.* 2009, 42, 224001–224016. doi:10.1088/0022-3727/42/22/224001
- [7] Misra, R. D. K. *Mater. Sci. Technol.* 2008, 24, 1011–1019. doi:10.1179/174328408X341690
- [8] Horák, D.; Babič, M.; Macková, H.; Beneš, M. *J. Sep. Sci.* 2007, 30, 1751–1772. doi:10.1002/jssc.200700088
- [9] Gu, H.; Xu, K.; Xu, C.; Xu, B. *Chem. Commun.* 2006, 941–949. doi:10.1039/b514130c
- [10] Franzreb, M.; Siemann-Herzberg, M.; Hobley, T. J.; Thomas, O. R. T. *Appl. Microbiol. Biotechnol.* 2006, 70, 505–516. doi:10.1007/s00253-006-0344-3
- [11] Safarik, I.; Safarikova, M. *Biomagn. Res. Technol.* 2004, 2, No. 7. doi:10.1186/1477-044X-2-7
- [12] Pankhurst, Q. A.; Connolly, J.; Jones, S. K.; Dobson, J. J. *Phys. D: Appl. Phys.* 2003, 36, R167–R181. doi:10.1088/0022-3727/36/13/201
- [13] Safarik, I.; Safarikova, M. *J. Chromatogr., B: Biomed. Sci. Appl.* 1999, 722, 33–53. doi:10.1016/S0378-4347(98)00338-7
- [14] Wakamatsu, H.; Yamamoto, K.; Nakao, A.; Aoyagi, T. *J. Magn. Magn. Mater.* 2006, 302, 327–333. doi:10.1016/j.jmmm.2005.09.032
- [15] Sun, Y.; Ding, X.; Zheng, Z.; Cheng, X.; Hu, X.; Peng, Y. *Chem. Commun.* 2006, 2765–2767. doi:10.1039/b604202c
- [16] Brazel, C. *Pharm. Res.* 2009, 26, 644–656. doi:10.1007/s11095-008-9773-2
- [17] Gelbrich, T.; Feyen, M.; Schmidt, A. M. *Macromolecules* 2006, 39, 3469–3472. doi:10.1021/ma060006u
- [18] Kaiser, A.; Gelbrich, T.; Schmidt, A. M. *J. Phys.: Condens. Matter* 2006, 18, S2563–S2580. doi:10.1088/0953-8984/18/38/S03
- [19] Schmidt, A. M. *Macromol. Rapid Commun.* 2005, 26, 93–97. doi:10.1002/marc.200400426
- [20] Ohnishi, N.; Furukawa, H.; Hideyuki, H.; Wang, J.; An, C.; Fukusaki, E.; Kataoka, K.; Ueno, K.; Kondo, A. *NanoBiotechnology* 2006, 2, 43–49. doi:10.1007/s12030-006-0006-7

- [21] Lai, J. J.; Hoffman, J. M.; Ebara, M.; Hoffman, A. S.; Estournès, C.; Wattiaux, A.; Stayton, P. S. *Langmuir* 2007, 23, 7385–7391. doi:10.1021/la062527g
- [22] Kondo, A.; Kamura, H.; Higashitani, K. *Appl. Microbiol. Biotechnol.* 1994, 41, 99–105. doi:10.1007/BF00166089
- [23] Heskins, M.; Guillet, J. E. J. *Macromol. Sci., Part A: Pure Appl. Chem.* 1968, 2, 1441–1455. doi:10.1080/10601326808051910
- [24] Schild, H. G. *Prog. Polym. Sci.* 1992, 17, 163–249. doi:10.1016/0079-6700(92)90023-R
- [25] Chanana, M.; Jahn, S.; Georgieva, R.; Lutz, J.-F.; Bäuml, H.; Wang, D. *Chem. Mater.* 2009, 21, 1906–1914. doi:10.1021/cm900126r
- [26] Magnetic Beads Thermo-Max. [http://www.magnabeat.com/e\\_index.html](http://www.magnabeat.com/e_index.html) (accessed June 1, 2010).
- [27] Perruchot, C.; Khan, M. A.; Kamitsi, A.; Armes, S. P.; von Werne, T.; Patten, T. E. *Langmuir* 2001, 17, 4479–4481. doi:10.1021/la0102758
- [28] Chen, X. Y.; Randall, D. P.; Perruchot, C.; Watts, J. F.; Patten, T. E.; von Werne, T.; Armes, S. P. *J. Colloid Interface Sci.* 2003, 257, 56–64. doi:10.1016/S0021-9797(02)00014-0
- [29] Li, D.; Sheng, X.; Zhao, B. *J. Am. Chem. Soc.* 2005, 127, 6248–6256. doi:10.1021/ja0422561
- [30] Li, D.; Jones, G. L.; Dunlap, J. R.; Hua, F.; Zhao, B. *Langmuir* 2006, 22, 3344–3351. doi:10.1021/la053103+
- [31] Wang, S.; Zhou, Y.; Guan, W.; Ding, B. *Appl. Surf. Sci.* 2008, 254, 5170–5174. doi:10.1016/j.apsusc.2008.02.021
- [32] Gou, Z.; Chen, Y.; Zhou, W.; Huang, Z.; Hu, Y.; Wan, M.; Bai, F. *Mater. Lett.* 2008, 62, 4542–4544. doi:10.1016/j.matlet.2008.08.035
- [33] Gelbrich, T.; Reinartz, M.; Schmidt, A. M. *Biomacromolecules* 2010, 11, 635–642. doi:10.1021/bm901203z
- [34] Gelbrich, T.; Marten, G. U.; Schmidt, A. M. *Polymer* 2010, 51, 2818–2824. doi:10.1016/j.polymer.2010.02.032
- [35] Lutz, J.-F.; Stiller, S.; Hoth, A.; Kaufner, L.; Pison, U.; Cartier, R. *Biomacromolecules* 2006, 7, 3132–3138. doi:10.1021/bm0607527
- [36] Kaiser, A.; Liu, T.; Richtering, W.; Schmidt, A. M. *Langmuir* 2009, 25, 7335–7341. doi:10.1021/la900401f
- [37] Schmidt, A. M. *Colloid Polym. Sci.* 2007, 285, 953–966. doi:10.1007/s00396-007-1667-z
- [38] Schmidt, A. M. *J. Magn. Magn. Mater.* 2005, 289, 5–8. doi:10.1016/j.jmmm.2004.11.003
- [39] Schmidt, A. M. *Macromol. Rapid Commun.* 2006, 27, 1168–1172. doi:10.1002/marc.200600225
- [40] Hergt, R.; Dutz, S.; Müller, R.; Zeisberger, M. *J. Phys.: Condens. Matter* 2006, 18, S2919–S2934. doi:10.1088/0953-8984/18/38/S26
- [41] Müller, G.; Dutz, S.; Hergt, R.; Schmidt, C.; Steinmetz, H.; Zeisberger, M.; Gawalek, W. *J. Magn. Magn. Mater.* 2007, 310, 2399–2401. doi:10.1016/j.jmmm.2006.10.772
- [42] Glöckel, G.; Hergt, R.; Zeisberger, M.; Dutz, S.; Nagel, S.; Weitschies, W. *J. Phys.: Condens. Matter* 2006, 18, S2935–S2949. doi:10.1088/0953-8984/18/38/S27
- [43] Massart, R.; Cabuil, V. *J. Chim. Phys. Phys.-Chim. Biol.* 1987, 84, 967–973.
- [44] Frickel, N.; Messing, R.; Gelbrich, T.; Schmidt, A. M. *Langmuir* 2010, 26, 2839–2846. doi:10.1021/la902904f
- [45] Matyjaszewski, K.; Davis, T. P., Eds. *Handbook of Radical Polymerization*; Wiley-Interscience: New York, 2002.
- [46] Rathforn, J. M.; Tew, G. N. *Polymer* 2008, 49, 1761–1769. doi:10.1016/j.polymer.2008.01.071
- [47] Shunmugam, R.; Tew, G. N. *J. Polym. Sci., Part A: Polym. Chem.* 2005, 43, 5831–5843. doi:10.1002/pola.21102
- [48] Monge, S.; Haddleton, D. M. *Eur. Polym. J.* 2004, 40, 37–45. doi:10.1016/j.eurpolymj.2003.08.003
- [49] Chantrell, R.; Popplewell, J.; Charles, S. *IEEE Trans. Magn.* 1978, 14, 975–977. doi:10.1109/TMAG.1978.1059918
- [50] Gneveckow, U.; Jordan, A.; Scholz, R.; Brüß, V.; Waldöfner, N.; Ricke, J.; Feussner, A.; Wust, P.; Hildebrandt, B.; Rau, B. *Med. Phys.* 2004, 31, 1444–1451. doi:10.1118/1.1748629
- [51] Falk, M. H.; Issels, R. D. *Int. J. Hyperthermia* 2001, 17, 1–18. doi:10.1080/02656730118511
- [52] Kaiser, A.; Winkler, M.; Krause, S.; Finkelmann, H.; Schmidt, A. M. *J. Mater. Chem.* 2009, 19, 538–543. doi:10.1039/b813120c
- [53] Néel, L. C. R. *Hebd. Seances Acad. Sci.* 1949, 228, 64–66.
- [54] Brown, W. F. *J. Appl. Phys.* 1959, 30, S130–S132. doi:10.1063/1.2185851
- [55] Feyen, M.; Heim, E.; Ludwig, F.; Schmidt, A. M. *Chem. Mater.* 2008, 20, 2942–2948. doi:10.1021/cm703419t
- [56] Chemagen AG: activated M-PVA Magnetic Beads AK11, protein binding capacity 8–20 mg·g<sup>-1</sup>. <http://www.chemagen.com/activated-m-pva-magnetic-beads.html> (accessed June 1, 2010); micromod: nanomag@-D (streptavidin), streptavidin functionality 1.5–2.0 mg·g<sup>-1</sup> (<http://www.micromod.de/scripts/datasheet.asp?sid=929022981&prod=09-19-252&lng=g&typ=1>, accessed June 1, 2010).
- [57] Asgeirsson, B.; Cekan, P. *FEBS Lett.* 2006, 580, 4639–4644. doi:10.1016/j.febslet.2006.07.043
- [58] Erlanger, B. F.; Kokowsky, N.; Cohen, W. *Arch. Biochem. Biophys.* 1961, 95, 271–278. doi:10.1016/0003-9861(61)90145-X
- [59] Lineweaver, H.; Burk, D. *J. Am. Chem. Soc.* 1934, 56, 658–666. doi:10.1021/ja01318a036
- [60] Batz, H.-G.; Franzmann, G.; Ringsdorf, H. *Angew. Chem.* 1972, 24, 1189–1190. doi:10.1002/ange.19720842410

#### AUTHORS

**First Author** – DARSANA.M.D, MTech polymer, Mba, Lecturer  
, polymer technology, kottayam, Email: dleda@rediffmail.com



# Marketing films through Social Realities: Shyam Benegal's 'Welcome to Sajjanpur'- A Case Study

Ms. Suparna Naresh and Dr. Jagadeesh Prakash

Department of Communication, Bangalore University, Bangalore (India)

**Abstract-** The success of a film in recent years has been largely dependent on the marketing of the film. Since cinema has always had a profound influence on the lives of people, being a larger than life media, film makers go the extra mile to woo the audience. Be it sci-fi, love stories, action dramas or family sagas, the marketing of the package is very important. Keeping this in mind, over the years the ways of presenting themes in films have been varied and innovative. Social realities have been presented by film makers often in a serious tone creating a niche audience for the same, distancing such films from a mass audience. In recent times film makers have tried to portray social realities differently. In a first of its kind, Shyam Benegal has attempted to portray social realities through the tool of humour and satire. The present paper will attempt to study this practice of using social realities as a marketing tool by film makers, with special emphasis to Shyam Benegal's 'Welcome to Sajjanpur'.

**Index Terms-** Marketing, Social Realities, Shyam Benegal, Welcome to Sajjanpur

## I. INTRODUCTION

“As a film-maker pure and simple it can be said with some accuracy that no director since Satyajit Ray has done more for Indian films than Shyam Benegal...” “Benegal's films, whether cultural or political, are models of their kind, showing that his commitment is not confined to fiction but securely based on facts as well as imagination...” -Derek Malcolm

None could have put this better or stronger than Derek Malcolm, the famed film critic and self confessed lover of Indian cinema. It is a fact that Indian cinema, more specifically Hindi cinema in its hundred odd years of existence, has strived to present the case of this nation, her people and society time and time again- warts and all.

From the very first mythological *Raja Harishchandra* to the contemporary city centric *Wake-up Sid* Hindi cinema has explored different facets of Indian society. The 1950s had great stalwarts like Mehboob Khan, Raj Kapoor, Bimal Roy and Guru Dutt dealing with a wide spectrum of themes such as nation-self conflict (*Bandini*), creative/commercial success (*Pyaasa*), women power (*Mother India*) and small town values versus big city survival games (*Shree 420*, *Aawara*).

Be it class divide, peasant revolt, capitalist greed or the noble poor- all these themes have been remarkably presented through the film noir of the Hindi film industry through the ages.

Historians and academicians have often depended on films for studying the evolution of Indian society, so great has been the reflection of society through this medium. It is an accepted fact

that cinema much like literature and art reflected society in varying shades- either through popular cinematic mode or through alternate cinematic styles.

Unlike popular cinema of Raj Kapoor or Mehboob which largely used melodrama, music and money, Benegal's films have almost always been true to reality, much like his predecessor and mentor Satyajit Ray. In Benegal's films we get to see a strong influence of the Italian neo-realism that had been used in patches by Bimal Roy in his *Do Bigha Zameen* and a great deal of it in Ray's Bengali film *Pather Panchali*. Ray's films which were quintessentially Bengal centric enjoyed the full bodied public support and thereby continued to take the maker to great heights of recognition both in Bengal and outside of India as well. Benegal unfortunately has had to constantly keep the ghosts of the powerful Bombay film industry at bay in order to forge a path for himself that was distinct and different from all that had been done earlier. Benegal's first film *Ankur* was released at a time when the Bombay film industry unleashed mega blockbusters like *Zanjeer* and *Yadon ki Baraat*, yet went on to create a niche for the film maker and paved the way for more such films from his stable.

Benegal's films have always been close to reality, placing his stories in specific contexts, constantly making use of the marginalized voice unheard, using themes as varied as caste, gender and socio-economic divide. To give credit where it is due, Benegal has given shape to the parallel or alternative cinema movement in India having made nearly twenty odd films in this genre.

His film *Welcome to Sajjanpur* very nearly defines Shyam Benegal's genre of film making exhibiting little of his brand of film making, except perhaps in relation to the themes presented in the film. Here lies the researcher's curiosity and interest.

*Welcome to Sajjanpur* was perhaps the only saving grace of the year 2008 as a commercially successful film having made excellent business at the box office with the likes of *Jannat*, an unadulterated commercial venture from the production house of Mahesh Bhatt.

The researcher would like to explore the different facets of this film and find plausible answers to questions related to the film maker's oeuvre and his penchant for trying to reflect a slice of society.

It would add to the study if the researcher is able to discount the critics who have been vocal in criticizing Shyam Benegal for selling out to commercial interests by changing his sensibilities thereby helping to finally put the last nail in the coffin otherwise known as parallel cinema.

## II. SOCIAL REALITIES AND FILMS

“I don’t know if cinema can actually bring about change in society. But cinema can certainly be a vehicle for creating social awareness. I believe in egalitarianism and every person’s awareness of human rights. Through my films I can say, ‘here is the world and here are the possibilities we have’. Eventually it is to offer an insight into life, into experience, into a certain kind of emotive/cerebral area”. – Shyam Benegal.

Of all mass media systems cinema by far is considered the most potent and effective having been equipped with a larger than life capacity to present the message of the maker. Added to this film makers of Europe, US and India have used the true-to-reality style of presentation to capture society in all its starkness. For most part this was done to add a level of seriousness to societal themes which were previously ignored and diluted to gain popular support and mass appeal.

Be it popular cinema or alternate/parallel cinema, both have and continue to draw heavily from the immediate reality of the times, the only difference being the manner in which these themes of reality are represented. Where popular cinema chooses to explore the slice of reality with a heavy dose of hype and exaggeration, alternate/parallel cinema chooses to say it without much fan fare. The idea of cinema is to reflect the society for greater impact.

One of the most strongly supported proposition in communication research today is that content in mainstream media, especially cinema, reinforces existing social, economic and political institutions as well as dominant values and normative systems. Cinema is seen as a product of a complex interaction between media institutions and other social actors, including governmental agencies, businesses, political parties, social movements and social groups.

This act of reflecting society is by no means a recent phenomenon. From the earliest films in the world, film makers have been capturing the essence of society in all earnestness, helping cinema to truly be an act of social commentary.

Orson Wells wrote, directed and starred in *Citizen Kane* in the year 1941, which was loosely based on the life of newspaper tycoon William Randolph Hearst. He included condensed time sequences and unusual camera angles to represent the failed life of a megalomaniac newspaper baron. Though, a commercial failure the film is considered a classic to this day for its sheer experimentation and treatment.

Many films in the US during the 1960s reflected the nation’s conflict over the Vietnam War, youthful rebellion, Civil Rights movement and even militant Black Power efforts. In fact, it is said that social conflict and social statement films dominated this decade. Film makers also moved away from the structural narrative that had dominated earlier to more episodic narratives with less foreshadowed endings. Themes tried to break the standard format of earlier times with heroes portrayed as being amoral, sex often fused with violence rather than romance and politics and political corruption often depicted explicitly.

Cinema in India has followed a very similar trajectory like its American counterpart. By the early 1970s cinema was expected to be a medium of “Indian culture and society providing healthy entertainment, “according to a film finance corporation dictat”.

Cinema while providing the expected healthy entertainment also became an idiom of protest. There was a decided separation amongst the film makers of India into two recognizable groups. One that chose to work on fantastical and populist themes and the other group that stuck to authenticity and realism. There was a collective trend against escapist film content. To quote Benegal himself “until cinema in the 1960s... apart from Bengal and Kerala there was no split yet in Hindi cinema because of the many crises in the post independent India. But then the formula became too hard, marketable ingredients became specific, the director was left inexpressive if he was working with stereotypes...”

Twenty odd years after independence, issues such as caste, class, rural poverty and urban angst were rife. The dissolution of the people with the system, government, society had to be told- social realities became the strongest metaphor for film makers to do so.

There are two principle reasons why this form of cinema turned into a national aesthetic programme. It represented the culmination of a cultural movement and defined its critical parameters. These film makers were hailed as the pioneers of cinema offering a different aesthetic and ideological vision breaking away from the studio controlled, market driven, entertainment based cinema of Bombay. Often called parallel or art house they are a genre by themselves. Over time debate has resulted in the grouping of film makers into two camps- the populist (commercial) and the alternative (parallel/art house). This happened to be the second reason why this form of cinema began to be experimented upon- a question of identity. This bifurcation has proved damaging to the movement of parallel art cinema having been forced to constantly fight the accusation of being elitist. Sangeeta Dutta, film critic and writer says, “The new-cinema film makers turned away from the stereotyped representations of the hero and glamorous heroin, from the pleasures of spectacle as in song and dance, action and from mandatory happy endings. Adapting the realist aesthetic, they cast new actors with no glamour attached to play recognizable characters in a specific milieu. Following the European neo-realists they opted out of studio environments and set their narratives in realist settings- in most cases rural locales. The economics of taking small units out into remote areas also suitably matched the ideology of new cinema.”

The alternate film-makers experimented with form, technique and content much like their European and American counterparts of the 50’s and 60’s. To quote Dutta, “Achieving a clever balance between art and commerce it was Shyam Benegal who quickly appeared at the zenith of the new movement. Cloaked into the new cinema ideology Benegal offered independently financed, engaging character driven narratives set in specific socio-political contexts. Realism in his films was a product of new social forces and relationships, depicting action which was contemporary and ideology which was secular and at the same time universal.”

Benegal says this of his films and style, “A passive acceptance of life is of no interest to anyone let alone a creative man. A dynamic society is always changing and the duty of every creative film maker is to locate and identify those catalytic elements which cause a change in society.”

Benegal too is highly critical about the modern day trends in film making. "Hindi films have created this pan-Indian industry which relates not to any specific culture. They have created their own culture, the Indian family and its traditions which define the film- and you can take this and set it down anywhere."

Many in the industry however feel that Benegal's criticism is exaggerated and in fact unwarranted. There are still those who continue to make films that they believe have something for the society, who have successfully blended the seriousness of alternate cinema without compromising on the commercial elements- using a perfect blend of both the genres. Often called multiplex movies such films are mostly directed towards an urban audience and make use of the closer to reality concept to the maximum. Presently with the healthy economic offering plenty of opportunities in India there are many talented film makers who are technically trained and come to this field with knowledge, know how and keenness to do things differently.

This kind of cinema meant for an educated, urban middleclass audience often relies on the everyday accounts of life from the very society it exists in. The concept of social reality in cinema has truly found its medium and groove. In recent years film makers have drawn heavily from newspaper accounts and actual events in society to depict their stories. Madhur Bhandarkar's *Chandini Bar* tackled the issue of trafficking in women in the big cities of India. It also bemoaned the problems of the young who take to the profession of bar dancing and the negative fallout thereof, of such a life style. His *Corporate* was a scathing commentary on the corruption and connivance that exists in the world of business. Bhandarkar's *Fashion* showed the seamy and the dirtier side of the fashion industry. Then there have been *Traffic Signal* and *Page 3* which exposed the sorry state of affairs in the state law and order machinery and in the field of print journalism respectively.

Of late many young film makers have been concentrating on probing the issues related to living in big cities, urban angst and frustration, problems of the young in a new India. Themes as varied as love at sixty, living together, teen pregnancies, nucleus families, problems of urban upwardly mobile couples, job stress, infidelity, and crime are represented repeatedly giving one the feeling that city-centered themes are almost formulaic. In fact of late most film makers have this tendency to make use of social realities as a replacement to literary themes since the general feeling is that there is greater identification with such realities on the part of the audience. Rather than being far removed from reality this slice of life instances seen in cinema are able to bridge the distance between the audience and the film maker. Such themes do not take time or effort to convince the cine goers.

Movies such as *Life in a Metro*, *Dil Chahata Hai*, *Phir Milenge*, *Bus Ek Pal* and *Wake up Sid* deal with city centric themes that are contemporary and realistic. Even movies that make political statements seem to use slice of lifestyle and social realities to explore the storyline of the film. *Rang De Basanti* was a commentary on the MIG controversy and the fall out thereof, while touching upon other issues such as vigilantism among the youth. To a large extent one can state that the urban audience in India almost expects cinema to be a true reflection of society these days. With exposure to cinema of the world urban India is

more exacting and critical and thereby more demanding of the film industry leading to more realistic cinema than ever before. With an NRI audience outside of India ever burgeoning the demand for such realistic yet stylishly made urban oriented films are great. Though such city centric themes were dealt with earlier as well- Ritwik Ghatak's *Meghe Dhaka Tara*, Satyajit Ray's *Jane Aranya*- to name a few, the sensibilities that were brought in were totally parallel cinematic rather than commercial as they are now.

"Indian modernity is cultivated in the work of Tamil film maker Mani Ratnam whose *Bombay* along with its scenes of violence and communalist mobilization presents images of an urban world of globalized affluence and smoothness. This is a world which points the strife and the misery of the streets and revolves around values of individualism and personalized relationships while at the same time showing these as not irreconcilable with other values of family loyalty and respect, thereby reconciling conflict and naturalizing life style of globalized modernity in their Indian setting".- Preben Kaarsholm, film critic.

Thus the socio-realistic themes of this new kind of cinema - referred to as multiplex, mid-order, and cross-over cinema- have been used in a reworked, changed fashion in contemporary cinema today. So we have Madhur Bhandarkar's *Chandini Bar*, Raj Kumar Santhoshi's *Lajja* and Mahesh Manjrekar's *Astitva*, three highly women centric films doing the rounds with a big dose of social realism.

The researcher's interest lies in this particular trend in contemporary cinema. Academically speaking this is a recent phenomena and much research or study has not been done on this particular issue. Further the research aims at studying the aspect of social realism through a content analysis of the film *Welcome to Sajjanpur* since this one film stands as an example amidst the multitude of films of this genre. It would make practical sense if only in a limited manner if this research could establish *Welcome to Sajjanpur* as a trend setter for film makers who are hard pressed to access great pieces of literature. This film may provide a formula for others in the usage of real life events and cases as a replacement of fictional stories.

These and other similar questions regarding social realism in Hindi cinema and the sensibilities of Shyam Benegal as a film maker will be probed in the course of the research.

### III. LITERATURE REVIEW

According to Christopher Williams, "Discussion of film (then) takes place in the confused but exciting arena ... in which historical, technological, aesthetic and sociological factors constantly jostle with each other... As yet we have no overarching theory which deals convincingly with all the factors and their relations with each other, though the attempt to construct one must remain a concern of serious interest in film. Realism is one of the partial theories we have instead...."

Looking through the film instead of at a constructed imaginary world, viewers take apart a scene to appreciate fragments which they constantly relate to everyday life. A woman who had been to see the blockbuster hit *Hum Aapke Hain Kaun*, which featured the story of a joint family wedding,



remarked that 'it was like going to a family wedding' (Srinivas 2002).

Inasmuch as the cinema is a highly valuable cultural institution for the elaboration of social reality through popular narrative; and narrative allows the creation of a symbolic universe which is marked by coherence and meaningfulness. Cinematic heroes and the narrative world in which they are developed fulfill a mythic function for they help to create a world which is meaningful and purposeful for us. In this sense, myth is a primary form of communication which facilitates our ability to understand the world around us and our place in it. It helps us to establish a map of our world, a compass for safe passage through unknown, uncharted seas. Through the mythic process, the world is seemingly punctuated with familiar landmarks although the terrain may be new and unfamiliar. The forms of popular media are indeed contemporary vehicles or carriers of myth. Writing particularly of the television medium but with implications as well for the cinema, Roger Silverstone observes that "the medium as a powerful cultural institution preserves, in form and function, much that we had previously granted only to oral or pre-literate societies, and secondly that it is through its forms... that this continuity can be established."

Storytelling and mythmaking are universal characteristics of cultural expression. As mythic expression, the filmic narrative involves the 'writing' of history or the telling of a people's story in their own images embodying their unique perspectives. Fundamentally, narrative is a cultural artefact which accounts for or provides legitimacy for a people and the (selectable-selected) options they take in order to define their existence.

Instead of diversion and escape, it is possible that the cinema can present a critique of existing society and its social relations; as well as help in understanding the problems we face and the pressing difficulties of our independence. A film can glorify the romance of tradition or it can help a society to understand and cope with cultural change allowing us to see our world in new ways. Witness the work of Ousmane Sembene, Africa's most important filmmaker who understands the power of film. Sembene believes that, "The artist must live within his community and denounce its weaknesses. The artist should assume such a role because he is more sensitive than others. He knows the magic of words, sounds and colours. He uses these elements to express what he and other people think and feel. The artist must not live in an ivory tower. He has social functions and responsibilities to fulfill" (Yearwood 1987).

Many media activists, especially alternative media producers, seem content to create their own media spaces, an activity with its own inherent satisfactions. Habermasian theory seems to offer the most insight, in part because of its own democratic normative commitments. If new social movements engage in defensive and offensive struggles for more democratic worlds, including vibrant public spheres, media activism is a sterling example of these politics. Its success will not likely bring it a collective identity or a well defined niche within the polity or social movement sector. This form of activism may be fated to remain a 'movement in itself', not (consciously) for itself (Caroll and Hackett 2006).

In his book *Communicating Unreality*, Gabriel Weimann explores the shaping of our perception of reality by mass media. He begins with the notion of a mediated world, then moves into

debates over effects, cultivation theory and the psychology of cultivation (2000).

Trinh T. Minh-ha, says "Reality is more fabulous, more maddening, more strangely manipulative than fiction." Now that documentary and fiction film modes are no longer thought of as separate and distinct, it is appropriate to reconsider documentary's 'special indexical bond' with the pro-filmic event" (Gaines and Renov 1999).

Benegal's films connect with real contexts in India. He roots his stories in credible places and times to address social themes. In contrast, the traditional Hindi movie offered an escape from reality. One of Benegal's films *Manthan*, for example, showed oppression and empowerment among dairy farmers. It was funded by over 500,000 rural farmers donating two rupees each.

Benegal's first four films were so realistic that they led critics to coin a new genre: India's "parallel cinema", or "middle cinema". Benegal himself dislikes these terms as much as the word "Bollywood", but they attest to the innovation he brought to Indian films. In the interview, Benegal criticized the cinema of the previous generations for being disconnected from real life. He likewise expressed concern that the new generation of films in India focus almost completely on the wealthy urban context.

Much like literature, art and music – films are also an important tool used by historians to study the evolution of contemporary society. A film is largely similar to a time capsule that can capture the essence and the mindset of the society at the time in which the film was made. Today, there are scholars who specialize in the study of contexts within films and there are even museums, libraries and entire universities that aim at understanding the pulse of a society through its Cinema. After gaining independence, cinema was an important tool used by the Indian intelligentsia for the purpose of setting an ideal and a goal. Films of the '50s portrayed exactly what the society of the time wanted India to become. However, upon recognizing the flaws inherent in Indian culture, films such as *Neecha Nagar* and *Do Bigha Zameen* were made. These films aimed to address the various societal handicaps of India and convey the message that the path towards progress lay in overcoming these obstacles and working together (irrespective of caste and creed) to build a strong nation. The next significant era that must be understood while studying the Indian Film Industry is that of the '70s. While it is easy to typecast the films of this era into the categories of 'Zeenat Aman', 'RD Burman' and 'Flower Power' – in truth, there is a lot more to the films of this decade; contexts and subtexts are safely buried between very fine lines. Having started out (right after independence) with great hopes and dreams to build a strong nation, the generation of the 70's was disheartened to realize that their dreams had gone unfulfilled. The avoidance of social issues in the films of this era also reflects its pessimism. And then, we come to our decade, the decade that has probably made the least amount of impact on Indian movie history. The rise of consumerism is evident in the films of our time – especially with the aggressive marketing and advertising that is done through films. Who can forget the scene in *Taal* when the hero dares the heroine to drink out of his bottle of Coca Cola. And who sponsored this film? Surprise, surprise, it was Coca Cola (Rayman Gill 2008)!

The dramatic story of an army man's 'widow' being re-married and pregnant with her second husband's child when the first husband returns from a Pakistan jail is ready to be filmed by ad-maker Prabhakar Shukla. "Even social reality has to be presented in an entertaining manner. There'll be no songs or anything in my film. But the issue has to be entertaining. Otherwise who would want to sit through it? What really inspired me about Gudiya's story was the truth about gender discrimination underlining her plight. A man can marry four times but a woman can't ask for a divorce even once. Does human emotion have no value for the law? I've studied the law and respect it. My father is a lawyer," says Shukla (IANS 2009).

Richard Dyer (1993) has argued that the entertainment industry expresses (and satisfies) its audiences' need for utopian desires. He believes this is done by 'non-representational means' through the affect of music and colour amongst other techniques. Many viewers report that they watch Bombay cinema with a 'suspension of disbelief' (as Shahid, a film viewer, claimed) due to its lack of realism and its melodramatic mode of address. This was in contrast with others who felt that they did not want realism. When this predictable utopian ending is challenged, as in some art and experimental films, it is either applauded for its realistic sensibility or condemned for producing affects of hopelessness for those who are caught in dystopian realities. Naseema, who is a British Pakistani woman of 26 from Oldham, expressed intense anger when describing a film called *Chandni Bar* (Madhur Bhandarkar 2002) that had a sad ending. The realistic representation of the failed romance of the woman protagonist who had struggled all her life left Naseema feeling trapped while watching *Chandni Bar*- "It was such a nice film but the ending was so... she never escaped from it! I think that is the sort of thing that is a bit degrading for women. If someone in a difficult position was watching that what would they think? I am going to end up like that, there is no way I am getting out of that?"

*Welcome To Sajjanpur* is a comic satire on the lives of people living in a village and their issues. It is directed by National Award winning director, Shyam Benegal and stars Shreyas Talpade and Amrita Rao in lead roles. Supporting them are a host of talented actors—Ila Arun, Divya Dutta and Ravi Kishen, to name a few. The plot of the movie is well knit and neatly executed in the form of a story which keeps you engaged till the end.

The story is about a B.A graduate, who is unable to get a job and thus is forced to make a living out of writing letters for his fellow villagers. His real ambition, however, is to become a novelist and he is in search of a subject. Though, a villager, Mahadev (Shreyas Talpade) has the potential to change the lives of people around him through his letters. How he does this is shown through a satirical take on an Indian village. Mahadev's childhood love interest Kamla (Amrita Rao) is desperate for a word from her husband, who is employed in a construction site in the city of Mumbai. The couple are linked through the letters written by Mahadev the letter writer. A jealous Mahadev creates confusion and complexities between the couple by indulging in falsehood and opportunism. Other plots include a harried mother (Ila Arun) who wants to marry off her manglik daughter; Munni Bai, an eunuch, who is contesting the village elections and is threatened by an opposing candidate; and a love-sick

compounder who is head over heels in love with the widowed daughter-in-law of an army man. Mahadev manages to get the compounder married, provide police protection for Munni Bai and nearly kisses Kamla. All is good till he learns a shocking truth about Kamla's husband and Munni Bai is nearly killed. The story takes a new turn from here revealing a lot of truths not just in the movie but also about the society that we live in. The beliefs we follow. The corruption and the politics, even at the village level.

There are several incidents in the movie where one can see the dogmas prevalent in the society. The language and dialogues add to the rustic charm. The street play in the movie is one of the most direct attacks on the land purchase policies of big entrepreneurs at a meager price from innocent farmers. The message is loud and clear, however for that particular duration one feels a disconnection with the film. The movie in itself takes a mocking shot at various social issues, then the insertion of this street play seems forceful and needless. Apart from this the movie runs flawlessly till the end revealing certain surprises and shocks. The performance of the actors adds to the credit of the movie.

The music in the movie is given by Shantanu Moitra of *Parineeta* fame. Songs, though not much of a hit, are quite light and hummable. The song 'Sitaram' is played throughout the movie in the background and is in a way the theme song. Apart from that all songs have a social message behind them. Cinematography is praiseworthy. The sets give you the feel of a real village and transport you to the pastoral or rather rustic life of the village. Cameras and lights are used very well to bring out a bright and colourful look in the movie. There is not a dark moment in the movie. If at all there is, it does not stay for long. The movie, though not inspired by any real life incident, does, however describe life as it really is. Indiatimes terms it as Shyam Benegal's "most entertaining attempt, by far" and entertaining, it is (Viewpaper 2009).

#### IV. METHODOLOGY

Content analysis is a reality check in which the portrayal of a certain group, phenomenon, trait, or characteristic is assessed against a standard taken from real life. The congruence of the media presentation and the actual situation is then discussed. Gerbner (1969) compared the world of TV violence with real-life violence. Dixon and Liz (2000) compared the TV depictions of African-Americans and Latinos as law-breakers to real-life data. Content analysis also focuses on exploring the media image of certain minority or otherwise notable groups. In many instances, these studies are conducted to assess changes in media policy towards these groups, to make inferences about the media: responsiveness to demands for better coverage, or to document social trends.

Stern and Taylor (1997) found the portrayals of Asian-Americans in TV ads during the mid-1990s and reported that only 10% of the ads featured an Asian-American model.

Media studies effects is a relatively new field as regards content analysis. One method is cultivation analysis, in which the dominant message and themes in media content are documented, to see whether these messages foster similar attitudes among heavy media users.



Content analysis is also used in a study of agenda setting. An analysis of relevant media content is necessary in order to determine the importance of news topics. Subsequent audience research looks at the correspondence between the media's agenda and the audiences' agenda setting. Content analysis as a method of collecting data has been extensively used in film analysis. Film is an art form that offers a practical, environmental, pictorial, dramatic, narrative, and musical medium to convey a story. Although it can be viewed as a type of generic video, complex film editing techniques, such as the selecting, ordering, and timing of shots; the rate of cutting; and the editing of soundtracks, is required to produce a successful movie. Consequently, all of these special features need to be taken into account for better content analysis, understanding, and management.

A thematic analysis is a form of qualitative content analysis that has been used extensively in film analysis. The researcher views the film and notes similarities and differences appearing across the storylines and main characters. All information from the film is then incorporated in the assessment, including narration, story text, plot, soundtrack, and all main, supporting, and background characters.

The present paper draws heavily from thematic content analysis representing the primary data. The various themes will be contextualized and perceived from the parameters of language, settings and treatment. Secondary data will be culled from books, journals, research articles and newspaper content.

## V. DATA ANALYSIS & DISCUSSION

1. **Of Names and Nomenclatures:** the film begins with the protagonist Mahadev Khuswa commenting on the practice in India of changing established/historical names of villages, towns and big cities. Shyam Benegal's displeasure and sarcasm is seen very clearly, albeit voiced through Mahadev.

Political parties have always gained mileage out of gimmicky rituals in India. In the name of one's village/town/city pride they have often resorted to garner public support. Thus, over the past few years, Madras has become Chennai; Bombay has become Mumbai; Calcutta has turned into Kolkata and closer home, Bangalore is now Bengaluru, with many more cities awaiting change. Intellectuals have often questioned the logic behind these changes, but to no avail. Most political parties in India are highly regional, keen to play identity politics. There are controversies every day regarding language, caste, region, and religious status. Maharashtra has been in the eye of the storm due to regional parties like Shiv Sena and of late Maharashtra Navnirman Sena (MNS), who are bent on staking the claim as the 'sole custodian of Maharashtra values'! Towards this goal these parties resort to a strong pro-Marathi stance. The recent shameful act of violence perpetrated by the MNS during the oath-taking ceremony of the non-Marathi MLAs in the state legislature is a case in point.

The Shiv Sena in Maharashtra has a huge vote bank and presence in the state because of its 'Marathi' agenda. Right from the sixties when scores of south Indians were driven away to make way for the Marathi Manoos. This linguistic chauvinism has helped it project a pro-Marathi stance winning it political

mileage. In 2008, so intense was Shiv Sena in milking the situation, using the Marathi fervour that it started a 'learn Marathi campaign' for the non-Maharashtrians. Ironically, the MNS have hijacked the campaign from the Shiv Sena and have been successfully using it for currying favour from the Maharashtra electorate.

Benegal sends a strong message voiced through the protagonist regarding the futility of such an exercise. The locale of the story is set in Sajjanpur (a place for the gentle folk) a quintessential Indian village. Mahadev hints at the original name of the village Durjjanpur (meaning a place for the ill-repute) at the very outset of the film. He bemoans the fact that despite the name change the village is infested with vice and sin- there lies the irony. Though Benegal couches this entire point in a humorous satire, it never-the-less finds its mark on the average cine watcher. The approach is effective without being preachy.

2. **Aaya Ram, Gaya Ram:** the politics of opportunism gets a strong mention in *Welcome to Sajjanpur*. The fact that politics makes for strange bedfellows is amply represented in this film. Mahadev, the protagonist, is a village letter writer/reader having ambitions of becoming a novelist. He is inadvertently privy to many strange political moves and shenanigans that result in friends turning foes and blood enemies miraculously becoming friends, all in the name of power and politics. India is a bedrock of political opportunism, where the policy of adapting actions and decisions for expediency and convenience by sacrificing ethical principles is a common enough sight.

Gaya Lal, an MLA in the Haryana state legislature, with his frequent defections to and from various political parties led to the creation of the phrase 'Aaya Ram, Gaya Ram', a pun or word play on the name Gaya. Ironically, his son Uday Bhan, in his capacity as an MLA in Haryana was charged under the anti-defection law in the year 2007 for having changed party affiliations once too often. There is a reference to this Aaya Ram, Gaya Ram practice in the film, once again indicating Benegal's political preoccupations.

3. **Of Scholarly Pursuits and Education:** In a recently published on-line article (Thirsting for 'Pyasa') noted director Sudhir Mishra was extremely condescending about the story-line and theme of most contemporary Hindi cinema. "The fare on offer in cinema halls around the country includes a lot of films that, though slickly produced, are superficial, unimaginative and even down-right stupid. They cannot be really called cinema- they are more like lifestyle ad films or worse promos for Bollywood stars. Though strongly worded there is a ring of truth to Sudhir Mishra's categorical statement. Hindi cinema no longer boasts of a Bimal Roy or a Guru Dutt who valiantly represented a young India's angst in the 50s and 60s. It is felt that contemporary Hindi cinema somehow lacks the depth and grounding that was seen in earlier films. Film makers no longer feel obliged to tackle subjects of social importance, and even if they do it is disguised in the styles of a commercial/popular film narrative which many feel detract from the seriousness of the theme and hence self-defeating in its goal.

According to film critic Anil Saari in his book 'Hindi cinema- An insider's View', "The need for a comprehensive world view imposes a highly stylized and formal format that in its broad outlines is symbolic, suggestive and allegorical of the total world view of life on the Indian scene. The Indian film makers, most of whom have quickly shed any pretensions to art that they might have started with and who work like hard-boiled businessmen dealing in an entertainment medium with heavy allegorical references, have evolved a list of ingredients that they consider acceptable to the mass audience. These elements can be seen in film after film, thereby provoking the label of the 'formula film'. Yet, because life is in a constant state of flux the formulas are shuffled and recast from time to time."

4. **Alternative sexual orientations and identities:** The film maker draws audience attention to the sensitive issue of alternative sexual identities. In a country like India, where the outlook of people towards such topics are suspect and laden this comes as a welcome move. It is said a film maker ought to probe the minds of the viewing public, this Benegal does by pitching the character of Munni Bai, an eunuch against the village strong man in the course of the local elections. We get to see the world from the eyes of people who are generally marginalized in Indian society and have no voice for themselves. The film maker draws sympathy as well as our concern through the portrayal of the transgender in the film.
5. **Big business and rights of the labour class:** The problems of the working class is not new in Hindi films. The treatment certainly is. In the films of the past portrayal has always been between the two extremes of commercial cinema such as Manoj Kumar's *Roti Kapda Aur Makan*, Hrishikesh Mukherjee's *Namak Haraam* which are decidedly commercial in their presentation and films like Mani Kaul's *Siddheshwari* and Govind Hihalini's *Aakrosh*. The present film is different in the sense that it presents the theme of labour upheaval in a realistic mode devoid of the starkness of the art house films that were dark and depressing and thus avoided by mass audience, and neither too frivolous and frothy like the commercial films often looked down upon by the intellectual class for making things trivial. The film *Welcome to Sajjanpur* looks at the theme of labour problems in India with a good balance of reality and tongue-in-cheek humour.
6. **Environment degradation:** The film maker handles the topic of environmental degradation in a humorous manner giving it the right amount of levity with seriousness thereby attracting viewer attention to the sensitive and contentious issue of environment protection. Through the eyes of the local snake charmer the audience get to see the environment in a totally different perspective.
7. **Blind beliefs, practices and rituals:** Mahadev the protagonist often meets the only emancipated young woman of the village of Sajjanpur Vindhya, who is seen driving a *Scooty* (two wheeler) like any city bred woman, is gainfully employed and for all purpose has no care in the world. However this is not the only truth

about her, being a manglik (born under questionable zodiac signs according to Indian society), she is considered unlucky by the villagers with the possible death of a husband if she were to marry. Her mother arranges for her wedding with a dog in order to get rid of the bad luck surrounding her. This is a common enough practice in India. This was the time when Indian media was abuzz with actress Aishwarya's marriage to a tree to get rid of the bad luck seemingly natural for a manglik.

8. **Superstition, God men and exploitation:** The film maker has strong opinions on god men and men of cloth. A scene where the women are shown doing rituals to propitiate the gods for blessings on the event of the festival *Karva Chauth* (a ritual done in north India by womenfolk for the welfare of their husbands) is a case in point. The scene has the women offering money to the *pundit* or village priest for conducting the grand ritual or *pooja* as they call it. The pundit demands a great deal of money and is shown exploiting the simple women folk of the village. Through the eyes of the women we get to see their plight and those of millions of similar women in India.
9. **Efficacy of new technology:** The coming of mobile telephones is seen as an end of an era of old world charm and the coming of new technology and new thinking. Mahadev is often seen cursing the new technology because this technology makes his letter writing profession defunct and un-necessary with people switching to cell messages rather than letters making his presence in the village un-important and un-wanted. This is a common refrain in real life as well where the lack of communication amidst people today is often blamed on the excessive use of technology such as new media, leading to greater distance between people. The film maker comments on this with the clever use of imagery and dialogue.
10. **Village politics:** The film takes us through the entire gamut of village politics with the local henchmen fighting the panchayat elections. The local people are torn between their sympathies for the capable candidate and their fear of the local hoodlums who terrorize the locals. The problem is compounded with the fact that the competing candidate includes a transgender who wants to try her hand in politics as well. Facing death threat and public ignominy she contacts Mahadev for help which he gives under great duress. The problem though not new is given a new complexion and understanding with the portrayal of the transgender as the political aspirant.

Other topics that are dealt with in the film are migration to cities and alienation, kidney racket and medical fraud, caste and communal conflict, widow remarriage and re-habilitation, women's education and empowerment and many other issues that find contemporary relevance.

## VI. CONCLUSION

Shyam Benegal has used social realities to the exclusion of everything else in this film. The Village of Sajjanpur is a representation of the country, India, where all the issues pertinent to the entire country are played out clearly in the form of village matters. In truth they are showing us a slice of India. This approach to the portrayal of social realities is very new.

A second fact is the manner in which social realities are presented – through humour instead of sobriety and pathos. Humour takes away the sting while at the same time making it more meaningful and close to us.

The film is likened to a newspaper in that the topics presented are extremely current almost like opening a daily newspaper and getting to know the day's news, this approach to contemporary issues is very new. Shyam Benegal has always prided himself in dealing with one issue at a time but through this film he has touched base with several crucial issues of our times.

We see a change in Shyam Benegal's style as well. Where he would be stark and bleak in his presentation he has used a pleasanter style to bond with his audience, ensuring greater financial success in this film than in his earlier films. He has thus created a new formula for presenting social realities in cinema. This approach is effective without being preachy.

Shyam Benegal has also used commercially viable actors rather than art house actors.

Lastly, on the question of whether films can bring in social change, they can, provided the films are seen by the mass audience, are made understandable for the common man and are less dark and preachy. This is seen from the reviews on *Welcome to Sajjanpur* and the box office collection of the film as well. Both factors exhibit the fact that people have welcomed the film since it was a commercial success and further critics and reviewers have given it a green signal. With time if there are many other attempts made on similar lines the impact of cinema can be judged clearly.

The need of the hour is for films to portray social realities in a manner that can be acceptable to the man in the street in order to bring about social change. There are strong possibilities of this happening with films such as *Welcome to Sajjanpur*.

## REFERENCES

- [1] Mottershead, Chris. Realism and the Cinema. Christopher William (ed.). Media, Culture and Society, 1981; 3; 304.
- [2] Srinivas, Lakshmi. The active audience: spectatorship, social relations and the expertise of cinema in India. Media, Culture and Society, 2002; 24; 155.
- [3] Carroll, William K. and Robert A. Hackett. Democratic media activism through the lens of social movement theory. Media, Culture and Society, 2006; 28; 83.
- [4] Mass Media, Social Control, and Social Change. David Demers and K. Viswanath (eds.). Sujeet Publications: New Delhi, 2004.
- [5] Krishnaswami, O.R and M. Ranganatham. Methodology of Research in Social Sciences. Himalaya Publishing House: Mumbai, 2008.
- [6] Vilanilam, J.V. Growth and Development of Mass Communication in India. National Book Trust: New Delhi, 2003.
- [7] Development and Transformation- themes and variations in India society. B.K. Nagla (ed.). Rawat Publications: New Delhi, 1993.
- [8] Datta, Sangeeta. Shyam Benegal. Roli Books Pvt. Ltd.: New Delhi, 2002.
- [9] City Flicks- Indian Cinema and Urban Experience. Preben Kaarsholm (ed.). Seagull: Calcutta, 2004.

- [10] Sharma, K.L. Indian Social Structure and Change. Rawat Publications: Jaipur, 2007.
- [11] Jha, Meeta Rani. The Politics of Emotion in British Asian Experiences of Bombay Cinema. Journal of Creative Communications, Aug 2007; vol. 2: pp. 101 - 121.
- [12] Pramod K. Nayar, Reading Culture: Theory, Praxis, Politics. New Delhi: Sage Publications, 2006.
- [13] Donnell, Alison. Feeling Good? Look Again!: Feel Good Movies and the Vanishing Points of Liberation in Deepa Mehta's Fire and Gurinder Chadha's Bend It Like Beckham. Journal of Creative Communications, Aug 2007; vol. 2: pp. 43 - 55.
- [14] Adoni, Hanna and Sherrill Mane. Media and Construction of Reality: Toward an Integration of Theory and Research. Communication Research, Jul 1984; vol. 11: pp. 323 – 340
- [15] Saari, Anil. Hindi Cinema- An insider's view. New Delhi: Oxford University Press, 2009.
- [16] Epstein, T. Scarlett. The remembered village: a modern classic. Contributions to Indian Sociology, Jan 1978; vol. 12: pp. 67 - 74.
- [17] Roy, Srirupa. Moving pictures: The postcolonial state and visual representations of India. Contributions to Indian Sociology, Feb 2002; vol. 36: pp. 233 - 263.
- [18] Mishra, Vijay Bollywood Cinema: Temples of Desire. London: Routledge, 2002.
- [19] Jeffrey, Robin. The Mahatma didn't like the movies and why it matters: Indian broadcasting policy, 1920s-1990s. Global Media and Communication 2006; 2; 204.
- [20] Yearwood, Gladstone L. Cultural development and Third World cinema. International Communication Gazette 1987; 39; 47.
- [21] Encyclopedia Britannica. (2009, November 28). The Construction of Social Reality. Retrieved from Encyclopedia Britannica: [www.britannica.com/EBchecked/topic/1308489/The-Construction-of-Social-Reality](http://www.britannica.com/EBchecked/topic/1308489/The-Construction-of-Social-Reality)

## AUTHORS

**First Author** – Ms. Suparna Naresh, PhD scholar, Department of Communication, Bangalore University, Bangalore, India (supsn67@yahoo.com)

**Second Author** – Dr. Jagadeesh Prakash, Professor, Department of Communication, Bangalore University, Bangalore, India.

# Navigation system for an autonomous robot using fuzzy logic

Vivek Yerubandi<sup>\*</sup>, Y. Mukunda Reddy<sup>\*\*</sup>, M. Vinod Kumar<sup>\*\*</sup>

<sup>\*</sup>.TECH, Vellore of Institute of Technology, Vellore

<sup>\*\*</sup>B.TECH, Vellore of Institute of Technology, Vellore

**Abstract-** Navigation system for an autonomous robot is an area that is undergoing constant development. This paper describes an autonomous robot that is capable of navigating in a real time environment. This can be achieved by obtaining the information about robot's environment by using sensors and process it. For implementation of obstacle avoidance, Fuzzy Logic approach is used and is implemented using Arduino-Uno board on mobile robot platform with three sets of ultrasonic sensors mounted on it. The Fuzzy Logic approach allows us to use the ultrasonic or infrared sensors that allow fast and cost effective distance measurements with varying uncertainty.

**Index Terms-** Fuzzy Logic, Obstacle Avoidance, Ultrasonic Sensors.

## I. INTRODUCTION

An autonomous robot is a robot working in an unmapped environment. The main problem of this robot is navigation and obstacle avoidance. The aim of this project is to build an autonomous robot that is capable of avoiding the obstacles in its path.

This can be achieved by obtaining the information about robot's environment by using sensors and process it. For processing the information we can use either probability theory or fuzzy logic methodology. Probability theory relies mostly on precision. Achieving high levels of precision requires highly precise sensors which are expensive and also the number of computations and complexity of the system increases. Whereas fuzzy logic provides the tolerance for uncertainty in the data received.

## II. ROBOTPLATFORM

### Hardware:

This is a microcontroller based mobile robot that contains Arduino development board fixed to the chassis and ultrasonic sensor modules mounted on the three sides of it for understanding the robots environment. The hardware implementation of the robot is shown in figure 1. Here Ultrasonic sensor modules gather the data and send it to the microcontroller through Arduino, where the data is processed and accordingly the actuations are made using DC motors.

### Software:

Arduino and Matlab are the software's that are used for performing obstacle avoidance using fuzzy logic technique. Here, Microcontroller is programmed using the Arduino

software, where the program calculates the distance of the obstacle and sends the data through serial port to the Matlab. Matlab uses this data as inputs for performing fuzzy logic and the fuzzy outputs are again sent to the arduino board through serial port for performing corresponding actuations.

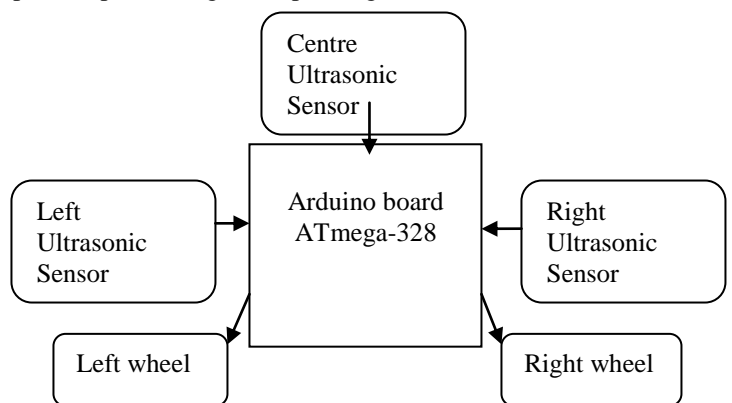


Fig 1. Block diagram of hardware architecture

## III. HARDWARE DEVELOPMENT AND IMPLEMENTATION

The proposed obstacle avoidance system uses fuzzy logic technique which makes it capable of reacting according to its environment. The system gathers the information from external world using Ultra-sonic sensors.

The information gathered by Ultrasonic sensors is used to calculate the distance of the obstacles. The microcontroller and Ultrasonic sensors that are used are described below.

### Micro Controller:

The microcontroller board used for this system is Arduino Uno which is based on ATmega328 microcontroller. Development board consists of fourteen digital I/O pins and six analog pins, with a flash memory of 32KB and EEPROM of 1KB operating at 16 MHz clock frequency.

### Sensors:

Detection of obstacles is done by using ultrasonic sensor modules. The module used here is HC-SR04. It is a Ultrasonic proximity sensor which uses sonar to measure the distance to an object. It can sense distance from 2cm -450 cms with an accuracy of 0.3cm and sensing angle less than 15degrees.

### Basic operating principle:



HC-SR04 has four pins - Vcc, GND, Trig, Echo. The module transmits a 40 KHz square wave signals when the pulses are given at Trig pin. When the signal is transmitted it sets the signal at echo – high. When an echo is received by receiver then the signal is set to low. The time duration of high signal is used to calculate the distance. No ranging data is provided by the module directly, it is calculated by the software using formula

Distance in cms = Duration of the high pulse in microseconds/29/2.

Since speed of sound = 29 microseconds/cm and signal travels out and back, so to calculate the distance we take half of the distance travelled.

For this system, three sets of Ultrasonic sensor modules are used for detecting the objects on the left, center and right of the robot.

#### IV. FUZZY LOGIC

Once the ranging data is calculated it is sent to serial port. Matlab reads the data from the serial port and uses it as inputs to the fuzzy logic.

Fuzzy logic technique has three main sections. They are:

- Fuzzification of the ranging data
- Fuzzy Control Rules
- Defuzzification

All these are performed in Matlab with the help of a special toolbox called fuzzy toolbox provided by Matlab.

##### Fuzzification of the ranging data:

The ranging data acquired from the three ultrasonic sensors are sent through the serial port to the Matlab. In the Matlab a Fuzzy Inference System is created using fuzzy logic toolbox. A Mamdani system with three inputs and one output is chosen as shown in fig 2. The three inputs are the ranging data from the sensors. The membership functions are used for converting the discrete data into a fuzzy value between 0 and 1 and fuzzy output values into discrete values.

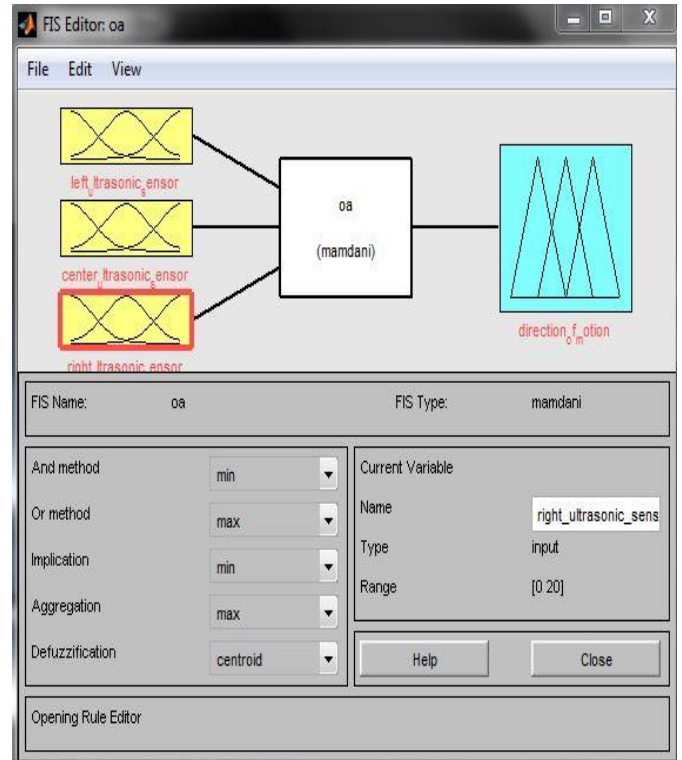
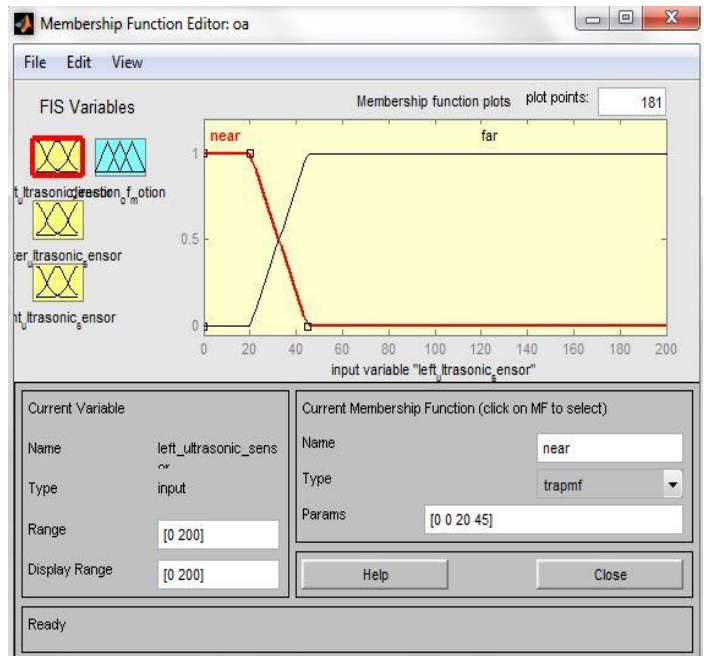
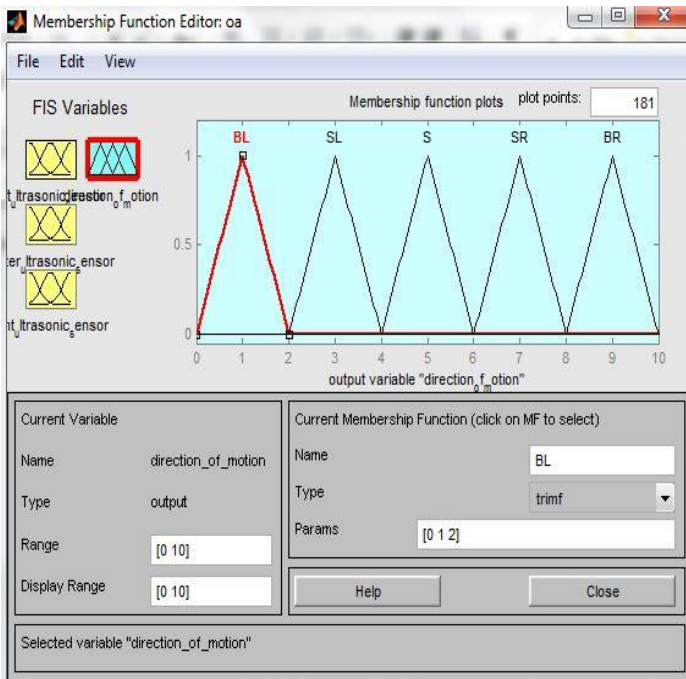


Fig 2. FIS of obstacle avoidance system

In this application mainly trapezoidal and triangular membership functions are used for the inputs (distance) and for the output (direction of motion). The membership functions for different fuzzy sets of inputs and output can be seen in fig 3.



(a)



(b)

**Fig 3. (a) Input Membership Functions (b) Output Membership Functions**

Fuzzy Control Rules:

In a fuzzy logic system, the rules define the output for any combinations of inputs.

Each input/output has different variables that are defined by the membership functions. For example, the distance input has either far or near, for direction of motion – Big Right (BR), Small Right (SR), Straight (S), Big Left (BL), Small Left (SL). The following Table 1 shows the rule base for this fuzzy controller.

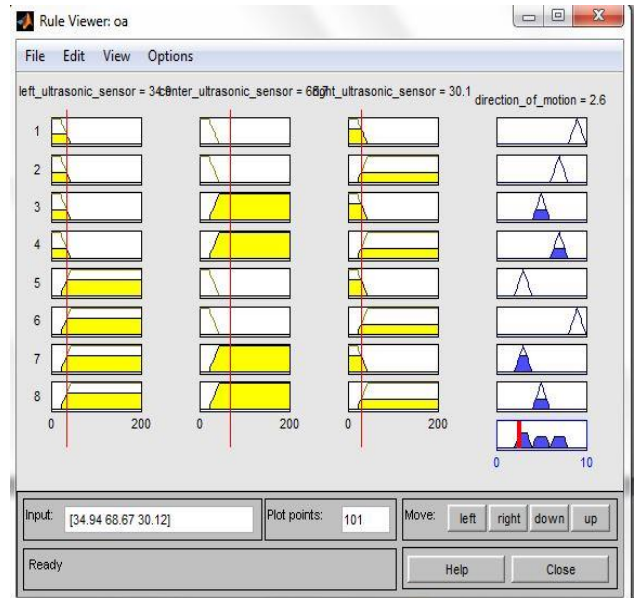
Rule	Left Sensor	Centre Sensor	Right Sensor	Direction of motion
1	Near	Near	Near	Big Right
2	Near	Near	Far	Small Right
3	Near	Far	Near	Straight
4	Near	Far	Far	Small Right
5	Far	Near	Near	Small Left
6	Far	Near	Far	Big Right
7	Far	Far	Near	Small Left
8	Far	Far	Far	Straight

**Table 1: Rule base**

Defuzzification:

The fuzzy output is the union of all the rules that are defined. Defuzzification is the conversion of fuzzy output to the crisp output. For the present system, defuzzification is done using centroid method and is given as:

$$Z^* = \frac{\int \mu(z)zdz}{\int \mu(z)dz}$$



**Fig 4. Rule viewer**

Overall System functionality algorithm:

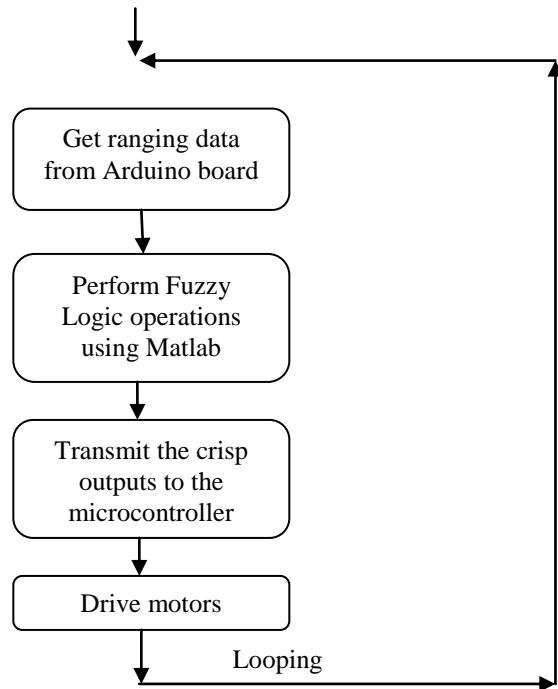


Fig 5. Algorithm for navigation of robot

- [5] D R Parhi, M K Singh, S Bhowmik "Intelligent Controller for mobile robot: fuzzy logic approach," 12th International Conference of International Association for Computer method and advances in Geomechanics, Goa, India, October 2008.

AUTHORS

**First Author** – Vivek Yerubandi, B.TECH, Vellore Of Institute Of Technology, Vellore

**Second Author** – Y.Mukunda Reddy, B.TECH, Vellore Of Institute Of Technology, Vellore

**Third Author** – M.Vinod Kumar Reddy, B.TECH, Vellore Of Institute Of Technology, Vellore

V. PRELIMINARY EXPERIMENTAL RESULTS

The mobile robot that is made using fuzzy logic technique is capable of avoiding the obstacles in its environment. Preliminary experiments are made using wired serial communication and the results obtained are seemed to be effective. However, sometimes Ultrasonic Sensors fail to detect the objects of particular geometries i.e, when the sonar beam hit a surface with oblique incidence, it would reflect away instead of going back as an echo and the obstacle is not detected.

VI. CONCLUSION

In this paper, Fuzzy Logic technique is successfully employed for obstacle avoidance using Arduino development board. The Arduino platform seems to be an excellent platform for the implementation of this project.

REFERENCES

- [1] ShigangCui,XiongSu,LiZhao,ZhigangBing,Genghuang Yang, "Study on ultrasonic Obstacle Avoidance of Mobile Robot on Fuzzy Controller", IEEE Conference on computer application and system modeling,china,2010.
- [2] S.Thongchai,S. Suksakulchai, D.M.Wilkes and N.Sarkar Sonar Behaviour-Based Fuzzy control for a Mobile Robot.Proceedings of the IEEE International Conference on Systems Man, and Cybernetics, 2000:435-440.
- [3] Khatib, O.: Real time obstacle avoidance for manipulators and mobile robots. Int.J.Robotics Research 5(1), 90-98(1986).
- [4] Hasan, K.M., Raza,A. Amar,M. "A Low cost microcontroller implementation of fuzzy logic bases hurdle avoidance controller for a mobile robot", Informatics,Electronics& vision,2013 International Conference.



# Assessment of the nutritional values of Dried Bread Fruit Peel Meal (DBPM) as a replacement for Maize in the Formulated Diet of Giant Africa Land Snail *Archachatina marginata* (swainson)

Ogunkunle Tajudeen

Department of Agricultural Biotechnology and Bioresources Development, National Biotechnology Development Agency, South West (BIODEC)  
Zonal Centre Owode Yewa South, Ogun state, Nigeria.

**Abstract-** A twelve (12) weeks experiment was conducted to investigate the nutritional values of dried bread fruit peel meal as a dietary replacement for maize on the growth of seventy five (75) grower giant African land snail (*Archachatina marginata*) of weight rang 38-42g in a completely randomized design (CRD) feeding trial. Fresh breadfruit peels were collected from roadside breadfruit fryers in Owode- Yewa town washed and sundried for one (1) week after which it was milled to form dried breadfruit peel meal (DBPM) then used as a replacement for maize at the level of 0, 25, 50, 75 and 100% in a formulated diet for giant African land snail as an alternative source of carbohydrate to form the dietary treatments viz; T<sub>A</sub> (control), T<sub>B</sub>, T<sub>C</sub>, T<sub>D</sub>, T<sub>E</sub> respectively. Each treatment was replicated three times with 5 snails per replicate. The formulated diets were supplied *ad-libitum*. Bi-weekly body weight gain (BWG), shell length (SL), aperture radius (AR) and shell width (SW) was measured. The results show that statistical significant different ( $P < 0.05$ ) occurred among the treatments in term of body weight gain (BWG), shell length (SL) aperture radius (AR) and shell width (SW). Dietary treatment T<sub>C</sub> (50%) dried breadfruit peel meal replacement was recorded to have influence more growth in all the parameters measured and recommended for use by animal feed industries and snail farmers mostly in the rural and peri-rural areas where fresh breadfruit is in abundant.

**Index Terms-** Acclimatized, Form utility, growth performance, rejuvenate, solarised, , wooden saucer.

## I. INTRODUCTION

African giant land snail *Archachatina marginata* is a common gastropod mollusc found in the rain forest and derived guinea savannah region in West Africa. Maize has remained the major and common source of carbohydrate in the formulated diet of farm animals. The ingredient is posing a serious competition treat between human and farm animals as it is consumed by man and also used as feed ingredient 'carbohydrate' source in farm animal feed. The need to convert or add form utility to agricultural waste materials such as fruit and tuber peels to effective use in animal husbandry and animal bioresources development cannot be over emphasised.

Fruit and tuber peels contain appreciable nutrient that are essential for growth and development. According to Ejidike and

Ajileye, (2007), farmers usually discard various locally available feedstuffs with great potentials for animal feed annually. Among the feedstuffs include cocoa pod hull, cowpea seed husk, cowpea seed hull, African breadfruit bract, and African breadfruit seed hull. Akinnusi, (1998) stated that micro livestock are among the cheaper sources of animal proteins and this include the micro livestock such as snails, rabbits and cane rats. (Oji, 2000).

According to Ajayi *et al.*, (1978), snail meat is particularly rich in protein. Imevbore and Ademosun (1988) indicated that snail meat has a protein content of 88.37% (on dry weight basis), low total fat (1.64%), saturated fatty acids (28.71%) and cholesterol (20.28mg/100g) (fresh sample). The nutritional quality of snail meat as reported by Kalio and Etela, (2011) is greatly influenced by the type and quality of diet supplied to the snail.

In a feed trial conducted by Omole *et al.*, (2013), weight gain, feed efficiency and dressing percentage were similar in the snails fed diet 0 and 50 percent yam peel as replacement for maize fraction of the diet. The parents and juveniles stock of *Achatina achatina* fed up to 50% sun-dried taro cocoyam meal diets has been reported to have performed very well in confinement without any adverse effects on reproductive traits.(Okon *et al.*, 2012).

Babalola and Akinsoyinu (2010) opined that (*A. marginata*) could utilize lettuce waste as well as cabbage waste as sole feed ingredient to increase animal protein supply in Nigeria.

The position of prepared feed as farm animal diets cannot be overemphasised. Ejidike,(2007) maintained that formulated and prepared artificial diet would provide constant supply of the animal feed as well as high potential of mass production of African giant land snail *Archachatina marginata* in the tropic thereby overcoming the scarcity associated with the raw feed ( plants and their waste) both in its availability and utilization.

Odo and Orji,(2010) maintain that during dry seasons when forages are generally not readily available, best growth performance of snail could be achieved in intensive rearing with the use of formulated mash during that season.

Akinnusi, (1998); Amusan and Omidiji, (1999) as cited in Ani *et al.*, (2013), maintained that the conventional feeds of snails are bread fruit, water leaf, pawpaw leaf, cabbage, carrot tops, ripe fruits (pawpaw, mango, plantain, banana, pineapple etc) . Breadfruit meal contains protein and energy that naturally endow it as a potential feed resource for poultry. Processing by

peeling, cooking or soaking in water can be used to reduce anti-nutritional factors in it. (Oladunjoye *et al.*, 2010). Besides, Ejidike and Ajileye, 2007 stated that breadfruit (*Telfaria africana*) seed hull meal TASHM is a suitable substitute for maize in (*A. marginata*) diets. Presently there is no known competition in the usage of breadfruit (*Arthocarpus communis Forst*) wastages as ingredients in animal feed in term of usage unlike maize, which is staple food in this part of the world and is been competed for in terms of human consumption, industrial and livestock industrial use making it quite costly for the use of an average snail farmer. In line with this, it is obvious that there is dearth of information on the utilization of dried breadfruit peel meal as a source of carbohydrate in the formulated diets of farm animals despite its availability as a waste product. This study therefore aimed at assessing the nutritional value of Dried Breadfruit Peel Meal (DBPM) as a replacement for maize in the formulated diet of African Giant Land snail *Archachatina marginata*.

## II. MATERIALS AND METHODS

### A. Location and duration of the experiment

The experiment was carried out under cocoa tree at a home garden 129, opposite new 192 Motorized Battalion barracks, Owode-Yewa South Local Government Area, Ogun State, Nigeria. Geographically, Owode - Yewa lies between latitude  $6^{\circ} 48' N$ ,  $2^{\circ} 57' E$  and longitude  $6.8^{\circ} N$   $2.95^{\circ} E$  (Wikipedia, 2014). Ecologically, the area lies in the rain forest zone with two raining seasons from February- July and September –November. The rest months are characterized by dry season.

### B. Experimental diets

The experimental diet consisted of formulated feed with dried breadfruit peel meal as replacement for maize. Fresh bread fruit peels were collected from road side breadfruit fryers washed and sun-dried for one (1) week (Figure 1A) milled and used for the dietary treatment formulations. The formulated feeds were,  $T_A$  (0% control),  $T_B$  (25%),  $T_C$  (50%),  $T_D$  (75%) and  $T_E$  (100%) dried breadfruit peel meal (DBPM) replacement for maize. (Table 1).

### C. Experimental snail

One hundred and ten 110 grower snail (*A. marginata*) were purchased from Lusada Market along Agbara in Ado odo/ ota Local Government Area, Ogun State Nigeria. From these, seventy five (75) snail of weight ranging from (38 – 42g) were prudently sorted for the trial.

### D. Cleaning and rejuvenation of the experimental snails

The snails were carefully packed in clean untreated water, washed softly with hand and allowed to stay in the water for 3-4 minutes so as to rejuvenate the snails prior to acclimatization for two weeks.

### E. Experimental lay out

The experimental snails were housed in a pen (1.6 x 1.5 x 1.5m) made of bamboo, palm front and mosquito net under cocoa tree which provided shade cover for the pen with an opening for easy access. The surrounding was cleared and soaked with spent engine oil to prevent pest and predators attack on the snail.

### F. Procedures and management

Fifteen (15) rounded weaving baskets with lid made of palm front each with dimension 30 cm in diameter and height of 35 cm were purchased from Owode –Yewa South market. New wood

shavings was collected from a near- by saw mill industry, solarised following the procedure of (Ogunkunle and Lamidi, 2014) before used as bedding substrate on the floor and in each basket. The experimental snails were weighed individually to get the initial body weight, shell length (SL), aperture radius (AR) and shell width (SW) and randomly distributed into (5) baskets with five (5) snails per treatment (Figure 1B) replicated three time in a Completely Randomised Design (CRD). The formulated diets were moistened slightly to soften the feed mixtures and increase the water contents thus facilitate easy consumption by the experimental animals before fed to the snail at 13 – 14 hour daily in wooden saucer. The pen was sprinkled with water twice daily (morning and evening) to maintain and sustain cool and humid condition in the pen. Body weight gain (BWG), shell length (SL), aperture radius (AR) and shell width (SW) was taken fortnightly. Substrates were replaced every three weeks. Droppings were picked; the feeding troughs with leftovers were cleaned properly before fresh feed combinations were provided for the snails daily.

### G. Data collection and statistical analysis

Parameters measured were body weight gain (BWG) of the snail, shell length (SL), aperture radius (AR) and shell width (SW). Body weights were measured with digital sensitive balance (CAMRY, Model EK 5055) in grammas (Figure 1 C). The shell lengths were measured along the axis, aperture radii were measured using measuring tape, shell widths were measured round along the largest side of the shell all with the aid of thread and ruler data were analysed electronically using one-way analysis of variance (ANOVA) via the use of SPSS 21.0 statistical package and the differences among means obtained were tested for significance ( $P < 0.05$ ) via the use fisher Least Significant Difference. (LSD) procedures.

## III. RESULTS AND DISCUSSION

### A. Body weight gain (BWG)

The mean Bi- weekly change in body weight (Table 2) showed that there was significant difference ( $p < 0.05$ ) in body weight gain in snail fed with the formulated diet. The formulated diet 50% dried breadfruit peel meal replacement ( $T_C$ ) replacement revealed the highest body weight gain of 45.56g followed by ( $T_D$ ) 75% (DBPM) replacement with mean value of 44.59g while snail fed with 25% (DBPM) replacement ( $T_B$ ) has the least growth rate of 43.06g. This result is in line with the finding of (Omole, 2003 and Kehinde, 2009) who also recorded highest weight gain in snail fed 50% yam peel (YP) as replacement for maize.

### B. Shell length (SL)

There was significant ( $P < 0.05$ ) difference in shell length over the period of the experiment (Table 3). The mean Bi-weekly shell length was highest in ( $T_C$ ) 50% with 9.77cm value followed by ( $T_D$ ) 75%; 9.44cm with the least 8.58cm recorded for treatment ( $T_A$ ) 0% dried breadfruit peel meal replacement (DBPM) respectively.

### C. Aperture radius (AR)

There was no significant difference ( $P > 0.05$ ) in aperture radius in weeks 2, 4 and 6 but significant difference ( $P < 0.05$ ) was recorded in aperture radius in week 8, 10 and 12. Generally, the mean bi-weekly change in aperture radius (Table 4) showed

that snail fed with treatment (T<sub>C</sub>) 50% dried breadfruit peel meal (DBPM) replacement had the highest value of 5.92cm, followed by treatment (T<sub>D</sub>) 75% replacement with value of 5.81cm and least 5.28cm (T<sub>A</sub>). This is in line with the findings of Ogunkunle and Lamidi, (2014) who recorded no significant increase in aperture radius on snails fed with the mixture of dried pawpaw leave meal and groundnut cake mixture in week 2, 4, 6 and 8 but notable statistical different occurred in week 10

**D. Shell width (SW)**

There was a significant difference (P < 0.05) in the response of the experimental snail to the formulated diets along the weeks (Table 5) the mean bi-weekly change in width showed that snail fed with 50% breadfruit replacement (T<sub>B</sub>) had the highest width growth of 14.99, followed by snail fed with 75% breadfruit

replacement (T<sub>D</sub>), while those fed with 0% breadfruit replacement (T<sub>A</sub>) had the least 13.82cm respectively.

**IV. CONCLUSION AND RECOMMENDATION**

In conclusion, the best growth performance could be achieved in snail fed with formulated diet with dried bread fruit peel meal inclusion as an alternative source of carbohydrate. The study revealed that growers snail *Achachatina marginata* (swainson) fed formulated diet with up to 50 to 75% dried breadfruit peel meal (DBPM) as a replacement for maize performed very well most importantly in terms of body weight gain and therefore recommended for use by small, medium and commercial snail farmers and all farmers most especially in the rural area where there is abundance of breadfruit.

**FIGURES**



Figure 1: (A) Dried bread fruit peel, (B) Experimental snails, (C) snail on measuring scale.

**TABLES**

**Table 1: Formulated feed composition**

INGREDIENTS	T <sub>A</sub> 0%	T <sub>B</sub> 25%	T <sub>C</sub> 50%	T <sub>D</sub> 75%	T <sub>E</sub> 100%
Maize meal	55.70	41.77	27.85	13.93	0.00
*DBPM	0.00	13.93	27.85	41.77	55.70
Palm Kernal Cake	40.30	40.30	40.30	40.30	40.30
Bone meal	3.50	3.50	3.50	3.50	3.50
Premix/vit/min	0.50	0.50	0.50	0.50	0.50
<b>TOTAL</b>	<b>100.00</b>	<b>100.00</b>	<b>100.00</b>	<b>100.00</b>	<b>100.00</b>

\*DBPM- Dried Breadfruit Peel Meal

**Table 2: Mean body weight gain (BWG) of the snail (g)**

Formulated feed (Treatments)								
Weeks	T <sub>A</sub> 0%	T <sub>B</sub> 25%	T <sub>C</sub> 50%	T <sub>D</sub> 75%	T <sub>E</sub> 100%	Mean	P-value	SEM
Week 2	40.92 <sup>b</sup>	40.59 <sup>b</sup>	41.26 <sup>a</sup>	40.97 <sup>b</sup>	40.58 <sup>b</sup>	40.86	0.260	0.1103
Week 4	42.16 <sup>c</sup>	41.53 <sup>d</sup>	43.00 <sup>a</sup>	42.85 <sup>b</sup>	41.53 <sup>d</sup>	42.21	0.033	0.2132
Week 6	42.85 <sup>c</sup>	42.31 <sup>c</sup>	44.83 <sup>a</sup>	44.08 <sup>b</sup>	42.85 <sup>c</sup>	43.38	0.003	0.2818
Week 8	43.68 <sup>c</sup>	43.57 <sup>c</sup>	46.61 <sup>a</sup>	45.33 <sup>b</sup>	44.23 <sup>c</sup>	44.68	0.001	0.3404
Week 10	44.87 <sup>c</sup>	44.62 <sup>c</sup>	48.02 <sup>a</sup>	46.21 <sup>b</sup>	45.32 <sup>c</sup>	45.81	0.002	0.3706
Week 12	46.29 <sup>c</sup>	45.76 <sup>c</sup>	49.65 <sup>a</sup>	48.08 <sup>b</sup>	45.76 <sup>c</sup>	49.11	0.000	0.4394
Mean	43.46	4306	45.56	44.59	43.38			

Mean with same superscript along the same rows are not statistically difference at 0.05 level of confidence using Fisher's Least Significance Difference (LSD), SEM- Standard error of mean.

**Table 3: Mean shell length (SL) of the snails (cm)**

Formulated feed (treatments)								
Weeks	T <sub>A</sub> 0%	T <sub>B</sub> 25%	T <sub>C</sub> 50%	T <sub>D</sub> 75%	T <sub>E</sub> 100%	Mean	P- value	SEM
Week 2	7.69 <sup>a</sup>	8.05 <sup>a</sup>	8.68 <sup>a</sup>	8.07 <sup>a</sup>	8.39 <sup>a</sup>	8.18	0.507	0.17507
Week 4	8.27 <sup>b</sup>	8.39 <sup>b</sup>	9.42 <sup>a</sup>	8.50 <sup>b</sup>	8.69 <sup>b</sup>	8.66	0.227	0.17148
Week 6	8.44 <sup>b</sup>	8.61 <sup>b</sup>	9.53 <sup>a</sup>	9.26 <sup>b</sup>	8.85 <sup>b</sup>	8.93	0.210	0.16729
Week 8	8.68 <sup>c</sup>	8.89 <sup>c</sup>	9.85 <sup>b</sup>	9.86 <sup>a</sup>	9.09 <sup>c</sup>	9.27	0.049	0.17252
Week 10	9.14 <sup>c</sup>	9.36 <sup>c</sup>	10.41 <sup>a</sup>	10.38 <sup>b</sup>	9.68 <sup>c</sup>	9.79	0.047	0.18147
Week 12	9.28 <sup>c</sup>	9.63 <sup>c</sup>	10.73 <sup>a</sup>	10.54 <sup>b</sup>	9.97 <sup>c</sup>	10.03	0.022	0.17953
Mean	8.58	8.82	9.77	9.44	9.11			

Mean with same superscript along the same rows are not statistically difference at 0.05 level of confidence using Fisher's Least Significance Difference (LSD), SEM- Standard error of mean.

**Table 4: Mean aperture radius of the snails (AR) (cm)**

Formulated feed (treatments)								
Week	T <sub>A</sub> 0%	T <sub>B</sub> 25%	T <sub>C</sub> 50%	T <sub>D</sub> 75%	T <sub>E</sub> 100%	Mean	P-value	SEM
Week 2	4.86 <sup>a</sup>	4.92 <sup>a</sup>	5.03 <sup>a</sup>	4.94 <sup>a</sup>	4.92 <sup>a</sup>	4.94	0.970	0.06630
Week 4	5.01 <sup>a</sup>	5.21 <sup>a</sup>	5.48 <sup>a</sup>	5.49 <sup>a</sup>	5.24 <sup>a</sup>	5.29	0.518	0.09622
Week 6	5.21 <sup>a</sup>	5.45 <sup>a</sup>	5.83 <sup>a</sup>	5.84 <sup>a</sup>	5.58 <sup>a</sup>	5.58	0.226	0.10097
Week 8	5.32 <sup>c</sup>	5.57 <sup>c</sup>	6.07 <sup>a</sup>	5.96 <sup>b</sup>	5.69 <sup>c</sup>	5.73	0.136	0.10468
Week 10	5.55 <sup>c</sup>	5.86 <sup>c</sup>	6.43 <sup>a</sup>	6.18 <sup>b</sup>	5.87 <sup>c</sup>	5.98	0.011	0.09622
Week 12	5.75 <sup>c</sup>	6.01 <sup>c</sup>	6.68 <sup>a</sup>	6.47 <sup>b</sup>	6.09 <sup>c</sup>	6.20	0.006	0.10403
Mean	5.28	5.50	5.92	5.81	5.57			

Mean with same superscript along the same rows are not statistically difference at 0.05 level of confidence using Fisher's Least Significance Difference (LSD), SEM- Standard error of mean.

**Table 5: Mean shell width (SW) of the snails (cm)**

Formulated feed (Treatments)								
Weeks	T1 0%	T2 25%	T3 50%	T4 75%	T5 100%	Mean	P- value	SEM
Week 2	13.03 <sup>b</sup>	13.05 <sup>b</sup>	13.72 <sup>a</sup>	13.29 <sup>b</sup>	12.90 <sup>b</sup>	13.20	0.019	0.09447
Week 4	13.43 <sup>c</sup>	13.42 <sup>c</sup>	14.20 <sup>a</sup>	14.18 <sup>b</sup>	13.38 <sup>c</sup>	13.72	0.019	0.12540
Week 6	13.68 <sup>c</sup>	13.68 <sup>c</sup>	14.87 <sup>a</sup>	14.36 <sup>b</sup>	13.63 <sup>c</sup>	14.05	0.009	0.15662
Week 8	13.85 <sup>c</sup>	13.92 <sup>c</sup>	15.22 <sup>a</sup>	14.63 <sup>b</sup>	13.83 <sup>c</sup>	14.29	0.006	0.17194
Week 10	14.29 <sup>c</sup>	14.41 <sup>c</sup>	15.78 <sup>a</sup>	15.11 <sup>b</sup>	14.74 <sup>c</sup>	14.74	0.009	0.19720
Week 12	14.45 <sup>c</sup>	14.64 <sup>c</sup>	16.16 <sup>a</sup>	15.40 <sup>b</sup>	14.43 <sup>c</sup>	15.02	0.004	0.20540
Mean	13.79	13.85	14.99	14.450	13.82			

Mean with same superscript along the same rows are not statistically difference at 0.05 level of confidence using Fisher's Least Significance Difference (LSD), SEM- Standard error of mean.

REFERENCES

- [1] S. S Ajayi, O. Tewe, O. Moriarity . and M. O Awesu (1978), 'Observation on the biological and nutritive value of the African giant land snail (*A. marginata*)'. East Africa wild life journal. (16). pp 85-95.
- [2] O. Akinnusi, (1998), 'A practical approach to backyard snail farming. Nig. Journal of Anim. Production. 25:pp 193-197.
- [3] , A. O. Ani , C. C. Ogbu, C. O Elufidipe . and L. C .Ugwuowo. (2013). 'Growth Performance of African Giant Land Snail (*Achatina achatina*) fed varying dietary protein and energy Levels'. ARPN Journal of Agricultural and Biological Science Vol.8 Iss 2.p p184. Available at [www.arpnjournals.com](http://www.arpnjournals.com)
- [4] O.O Babalola, and A.O.Akinsoyinu,( 2010). ' Performance, carcass analysis and sensory evaluation of cooked meat of snaillets of African giant land snail (*Archachatina marginata*) fed pawpaw leaves, whole lettuce, lettuce waste and cabbage waste as sole feed ingredient. African Journal of Agricultural Research 5(17), pp. 2386-2391.Available online at <http://www.academicjournals.org/AJAR>
- [5] B.N Ejidike, and O .Ajileye, (2007). 'Nutrient Composition of African Breadfruit (*Treculia africana*) Seed Hull and its Use in Diets for the African Giant Land Snail, *Archachatina marginata*'.Pakistan Journal of Nutrition Vol 6. Iss 2:pp 201-203.
- [6] B.N Ejidike, (2007), 'Influence of Artificial Diet on Captive Rearing of African Giant Land snail *Archachatina marginata* Pulmonata *stylommatophora*'. Medwell j. of Animal and veterinary Advance Vol 6 Iss 8, pp1028 -1030



- [7] E. A Imevbore, and A. A Ademosun, (1988). 'The nutritive value of the African giant land snail (*A. marginata*)'. Journal of Anim. Prod. Resource. Vol 2,iss 8:pp 76-78.
- [8] G .A. Kalio, and Eleta, (2011), 'Nutritional and sensory profiling of the African Giant Land snail fed commercial type and leaf-Based Diet in Rain-forest Ecology'. African Journal of food, Agriculture, Nutrition and Development, Rural outreach programme Vol.11 Iss.5.<http://www.bioline.org.br/request?nd 11066>(Accessed on December 12, 2014)
- [9] A.S. Kehinde, (2009). 'Utilization of cassava peels products in the life cycle feeding of snails (*Archachatina marginata*)'. Ph.D Thesis, Department of Animal Science, University of Ibadan (Unpublished).
- [10] B.I Odo, and A.C .Orji, (2010). ' Evaluation of growth performance of snail fed different forage under intensive management'. Pakistani Journal of Nutrition.Vol.9 Iss.6.pp 543 – 546.
- [11] T. Ogunkunle, and A.A Lamidi (2014). 'Growth response of *Archachatina marginata* (Swainson) to brown pawpaw leaves meal (BPLM) and groundnut cake (GNC) mixture'. Global journal of Bio-science and Biotechnology, Vol.3 Iss.4: pp406-410. Available on line at <http://www.scienceandnature.org>
- [12] O. E Oji, . (2000). 'Promoting micro livestock production in Nigeria'. Proc. 26th Ann. Conf. Nig. Soc. for Anim. Prod. (NSAP), 19-23rd March, Umudike, Nigeria. pp. 330-331
- [13] B .Okon, ., L. A Ibom, ., E. E .Nsa, & J. A Ubua, (2012). 'Reproductive and Growth Traits of Parents and F1 Hatchlings of *Achatina achatina* (L) Snails under Mixed Feeding Regime with Graded Levels of Swamp Taro Cocoyam (*Cyrtosperma chamissonis*) and Paw paw leaves (*Carica papaya*)'. Journal of Agricultural Science; Vol. 4 Iss11; v4n11p289. URL: <http://dx.doi.org/10.5539/jas.v4n11p289>
- [14] O.A Oladunjo, D. Ologhobo, and .C. O .Olaniyi, (2010). ' Nutrient composition, energy value and residual antinutritional factors in differently processed breadfruit (*Artocarpus altilis*) meal. African'. Journal of Biotechnology Vol. 9 Iss27, pp. 4259-4263. Available online at <http://www.academicjournals.org/AJB>
- [15] A. J. Omole, C. N Okpeze, J. A Fayenuwo, . and T. O Olorunbohunmi . (2013). 'Effects of partial replacement of maize with yam peel (*Discorea rotundata*) in diet of juvenile snails (*Archachatina marginata*)'. African Journal. of Agricultural Research Vol.8 Iss.16. <http://www.academicjournals.org/AJAR>
- [16] A.J Omole, (2003). 'Nutrient requirement of different classes of snail (*Archachatina marginata*) at different stages of growth'. Ph.D Thesis, Department of Animal Science, University of Ibadan (Unpublished).
- [17] Wikipedia, (2014) Yewa south. [http://en.m.wikipedia.org/wiki/Yewa\\_south](http://en.m.wikipedia.org/wiki/Yewa_south).(Accessed 23 December July, 2014)

#### AUTHORS

**First Author** – Ogunkunle Tajudeen, Department of Agricultural Biotechnology and Bioresources Development, National Biotechnology Development Agency, South West (BIODEC) Zonal Centre Owode Yewa South, Ogun state, Nigeria.

**Correspondence Author** – Ogunkunle Tajudeen, (B.Agric) - Crop Production and crop Protection, (PGD) - Farm Management and Extension, E -mail: [ogunkunletajudeen@gmail.com](mailto:ogunkunletajudeen@gmail.com), Tel: +234(0)8029411206

# System development of mechanism, anchoring devices in pre and post Tensioned concrete structural elements.

Pradeep Nath Mathur\*, Prof.(Dr.) A. K. Sinha\*\*

\*HoD Apex Group of Institutions, Jaipur.

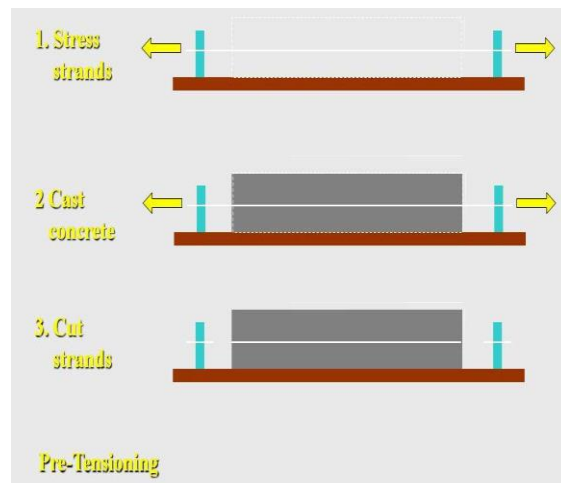
\*\*Director & H.O.D. Civil Engg. Suresh Gyan Vihar University, Jaipur

**Abstract-** The pre-stressing concrete technology is quite different from Rcc. Concrete Technology. The pre-stressing system devices are of two types, pre-tensioning & post-tensioning. By using prestressing for pre & post tensioning device mechanism development of Anchoring system in concrete structural element. In modern type of Pre stressing electricity with Low voltage and high current is used in anchoring device for a concrete member & sulphur Coating as a duct material before the casting of concrete member. While supplying electricity in the structure sulphur get melted up because heat generated in the structure. The structure could be anchored by nutting at both the ends.

## I. INTRODUCTION

Theoretical considerations precede the design and development of anchoring system. Pre stressing in concrete technology is quite different form reinforced concrete in the sense that technologically both are in divergent mode. Pre-stressing is the application of a predetermined force or moment to an element in structures such that combined internal stresses resulting from applied force or moment and positive from external loads will be within specific limits and hence section is entirely compressive. Wires or strands, that is TENDONS are stressed between two anchorages. In fact structural behavior of RCC and Pre-stressed concrete totally separate. While steel is an integral part in RCC. steel stressing. Bond between steel and concrete plays an important part in RCC. and tension in steel develops when concrete begins to crack and during cracking strains of concrete are transferred to steel through bond. In Pre-stressing bond between steel and concrete does not exist, that is stress in steel does not depend on strain in concrete. Stress in steel varies with bending moment along the length of beam in RCC. Whereas there is no variation in stress in steel along the length of beam in Pre-stressing giving anchoring a less complex analysis. Crack control in RCC. Is a problem so much so that stress in steel should be limited. In Pre-stressing with the inclusion of anchoring crack control is not difficult. There is no need to limit stress in steel.

The phenomena of steel acting as tension flange of a beam analogous to section is a part of RCC. Otherwise steel does not act as a tension flange in pre-stressed concrete giving rise to actual and not ambiguous analysis of anchors.



Post-tensioning Pre-stress diagram

## II. REVIEW OF LITERATURE

The design and development of anchoring mechanisms are a function of pre-stressing perfection the compression and takes part in resisting moments. There is no corrosion of steel and sections are much smaller. Self weight is reduced because anchors also do not add to self weight of structural elements, This saves cost of foundations which have to bear less loads.

According to **IS 1343 (1980)** anchoring devices may add to a smaller section of disadvantages along with high strength concrete and steel as well as skilled labor, yet there is an overall economy in using pre-stressed concrete because decrease in member sections results in decrease in design loads, Economical structure and foundations. The only common items in RCC. And pre-stressing are materials – concrete and steel, but anchors need high strength tendons to establish compressive stresses in all sections.

FRP reinforcement can have advantage over steel in being lighter in weight, higher in tensile capacity, more resistance to corrosion and electromagnetically transparent. Several manufacturing methods are available for fabrication of FRP reinforcement for concrete. For rod and grid type reinforcement, pultrusion and braiding are the most commonly used manufacturing methods because of low cost, high quality and efficient fiber orientation. Flat or round FRP rods come in a variety of surface shapes, E.g. Dimpled, Indented or Coated with sand in order to provide better bonding with concrete.

**Taerwe et. al. (1992)** has considered that concrete is conventionally reinforced with steel bars and tendons. It is well known that the deterioration of concrete structures can mostly be attributed to corrosion of the reinforcing steel. This results from exposure to environments high in moisture and chlorides. Chlorides come from sources such as sea water or de-icing salts used in the winter time on bridges and parking garages.

Coating the steel reinforcement with a layer of epoxy has been the most common method of several practices used for controlling corrosion some recent failures have left doubts about the dependability of epoxy coating protection. Galvanizing of steel reinforcement, another form of protective coating, is suspected of un satisfactory protection in chloride contaminated concrete, of impairing steel to concrete bonding & of causing hydrogen embrittlement of pre-stressing tendons.

**Nanny et.al. (1996)** concluded that ultimate load capacity is generally controlled by the anchor rather than the tendon itself, suggesting that anchor efficiency can be improved. It is explained that the three classes of anchor systems (That is wedge, resin potted and spike) offer advantages and disadvantages. The degree of complicity in terms of installation procedure varies for wedge type anchors, dry lubrication and sand coating on the two faces of the wedges are helpful. Protection of the tendon can be attained with a sleeve. High temperature did not adversely affect the performance of the system tested. Wedge anchor systems are suitable for pre-tensioning application.

Spike anchors if used with dry fiber ropes may work relatively well. This system requires the longest setup time resulting from the combination of removal of the plastic sheath, combing and spreading of the individual fibers and proper placement of the spike with a uniform distribution of fibers all around it.

For wedge anchors, grit should be present on the wedge surface to ensure proper gripping of the tendons. When comparing carbon stress tendons with Arapree tendons both of which utilize plastic wedges, the carbon stress system with applied grit does not show the slippage of the untreated Arapree wedges.

For resin/Grout Potted anchors, failure may be due to pull-out of the tendon from the resin/Grout anchor without rupture of the tendon however parabolic system may show shifting and erecting of the resin plugs. The plotted anchors are by for the easiest to setup for testing when pre-installed. The practical drawbacks include pre-cutting the tendons to length and curing time for the resin/Grout.

**Lin & Ned (2001)** assert that in pre-tensioning, anchoring mechanism is not integral working part of structural element. However at the construction stage and/or manufacturing of pre-tensioning members, tendons are stretched by jacks and anchored at the ends. After concrete has set and hardened, the tendons are separated from anchors thereby imposing pre-stressing in the beam or structural elements. The system consists of two bulk heads anchored against the ends of a stressing bed. The tendons are pulled between the two bulk heads. A pre-stressing bed is used for casting usual units and possibly shorter units. It supports vertical reactions due to which pre-stressing of bent cables can be done. Hoyer system shall be analyzed. The anchoring devices for holding pre-tensioning strands to the bulkheads remain on the

wedge and friction principle. One common device consists of a split cone wedge, which is made from a tapered conical pin. The existing tapered conical pin is drilled axially and tapped & then cut in half longitudinally to form pair of wedges. The anchoring block has a conical hole in which tapered conical pin holes are strands. These grips can be used for single wires as well as for twisted wire strands. Alternately the pin is not drilled, but is cut in half longitudinally and the flat surface is machined and serrated. As a third option, quick release grips which are more complicated and costly, are used especially when wires are to be held in tension only for short periods. Another method, under study is to add mechanical end anchorages to the pre-tensioned wires. Dorland anchorage, consisting of clips, can be gripped to the tendons under high pressure and the edges of the clips can then be welded together at several points. In such mechanical anchorages, tendons of greater diameter can be permitted. In post-tensioning systems, mechanical pre-stressing, electrical pre-stressing by application of thermal energy and chemical post-stressing by using expanding cement shall be the part of research.

### III. METHODOLOGY / LABORATORY WORK

Some of the systems shall be studied, analyzed and verified in efficiency and strength so that minimum pre-stress losses occur. The first anchoring system FREYSSINET had quite useful advantages and yet needed improvement and / or additions and deletions. Other systems under study shall be Magnel Blaton, Gifford Udall (with two types of anchoring-plate anchorage and tube anchorage), PSC Mono wire system & Lee Mecall systems.

Electric pre-stressing shall be experimented in which bars shall be stretched by means of heating using electrical energy. It shall be considered as a transition from RCC. to pre-stressing. Chemically pre-stressing or self stressing shall be experimented in which self stressing cement shall be used that expands chemically after setting and during hardening.

Finally comprehension of theoretical nature of pre-stressing anchoring technology which is a significant part can be analyzed on rational basis and critical study of the existing devices modification there of as well as attempt towards development of better and efficient mechanisms will be a purposeful possibility. Role of welding shall be attempted and highlighted practically for strong grips.

#### **Advantage of pre-stress concrete over RCC:**

- Complete section is in use hence smaller section is needed.
- Its shear resistance increased.
- It has more resistance to fatigue, impact and vibrations.

**Electrical pre-stressing :-** This is modern type of pre-stressing. We use electricity for working of Anchoring device system. It is introduced by Biller & Carlson. For post-tensioning we use sulphur coating to cause duct material while casting with concrete. When electric current is passed through the tendons it get heated up and sulphur coating is melted. The tendons ends as threaded & Nuted. By tightening them Anchoring of the section is achieved.



#### IV. PRACTICAL APPROACH

We consider for Fe-410 steel bar – 8mm  $\phi$

The properties comes between cast iron and wrought iron. It is having property of getting hardened and tempered, also has 0.1%-1.1% of carbon & granular like structure.

Its sp. Gr.-7.85 & melting point between 1300<sup>0</sup> to 1400<sup>0</sup> C.

The ultimate compressive strength is 180-350 MPa. &ultimate tensile strength is 310-700 MPa.

It is found to be tough, malleable and ductile in nature.

The coating thickness of sulphur material forming a duct, on steel bar shall be considering - 0.5 mm.

A mould is using to cast as a beam by concrete on coated steel bar. Mould is shown in figure below- dimensions 420x150x150 mm. cu.

M15 Grade concrete having ratio1:2:4 is prepared of required workability then it is pored to fill the mould to cast required beam. After 24 hours it is taken out from mould &cured for 7 days The casted beam required is two for our experiment of same dimensions. The prepared beam as figured below-

Now the base plate on both ends of beam is placed. Electric current is passed so that coating is melted & at bars nuts are tightened at both sides so that required anchoring purpose is solved.



FIGURE:- Beam with sulphur coated steel bar

**FIGURE: Transverse test on pre-stress beam**



**FIGURE : Transverse test on RCC beam**

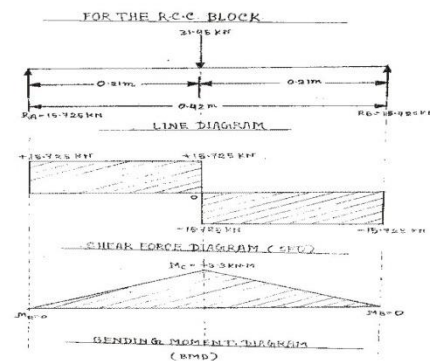


**Figure- Universal Testing Machine With Plotter & Hydraulic Load Dial**

#### Result –

The Peak load of Pre-stress beam = 32.50 KN.

The Peak load of RCC beam = 31.45 KN.



#### Beam with base plate and nut is shown in figure

Heat generated about 170<sup>0</sup> C which causes sulphur to be melt & bars to elongated at this time we will tighten the nuts by using mechanical tools. Some losses will occur in beam after anchoring been done hence it needs 24 hours for further test . Now considering beam as simply supported & using UTM (Universal Testing Machine) as for calculation of bending moment.

This process is applied for both the conditions that is flat & Transverse so that graphs may be made for both the conditions. Under UTM the distance between supports is fixed. Width, Thickness & Crosshead Travel is first found then Peak Load, Cross Head Travel at Peak & Transverse strength is found. Plotter attached with UTM machine draw complete graph till start to specimen break.

#### Transverse Test Report is as under:

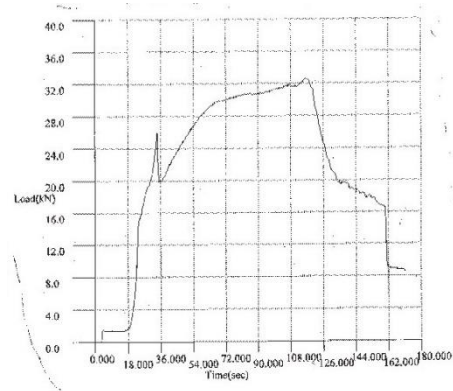
1)

Machine Model : TUE-C-1000.

Machine Serial No. : 2009/50

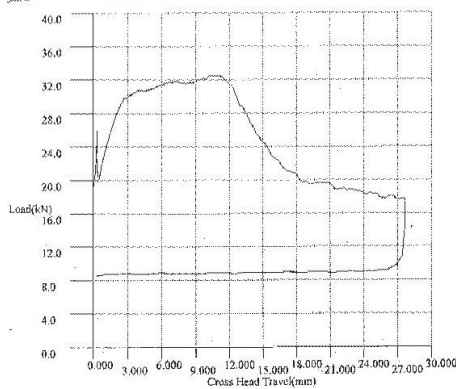
File name : A4, CIVIL, UTM.

Material Type : RCC Beam 1 (Pre-stress)  
Distance between  
Supports : 420.00 mm  
Width : 150.00 mm  
Thickness : 250.00 mm  
Max. Cross head  
Travel : 250.00 mm  
Peak Load : 32.50 KN.  
Cross head Travel  
at Peak : 11.20 mm  
Transverse strength :  $06.07 \text{ N/mm}^2$



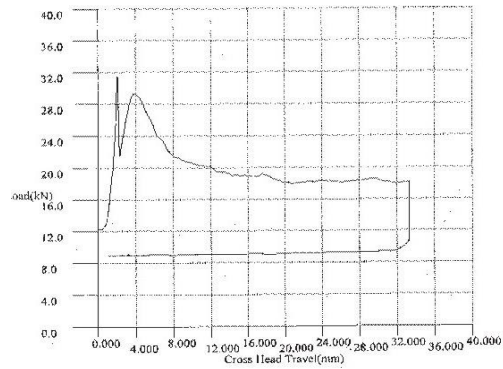
**Transverse Test Report is as under:**  
2)

Machine Model : TUE-C-1000.  
Machine Serial No. : 2009/50  
File name : A4, CIVIL, UTM.  
Material Type : RCC Beam 2 (Pre-stress)  
Distance between  
Support : 420.00 mm  
Width : 150.00 mm  
Thickness : 250.00 mm  
Max. Cross head  
Travel : 250.00 mm  
Peak Load : 32.50 KN.  
Cross head Travel  
at Peak : 11.20 mm  
Transverse strength :  $06.07 \text{ N/mm}^2$



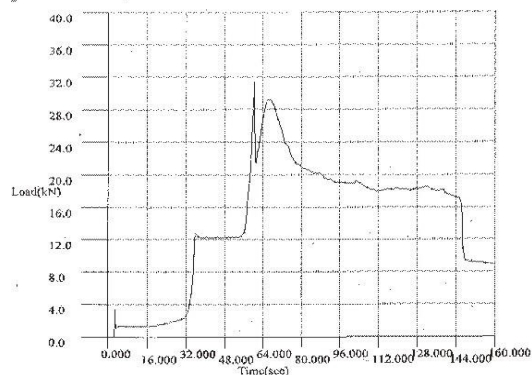
**Transverse Test Report is as under:**

3)  
Machine Model : TUE-C-1000.  
Machine Serial No. : 2009/50  
File name : A4, CIVIL, UTM.  
Material Type : RCC Beam 3  
Distance between  
Support : 420.00 mm  
Width : 150.00 mm  
Thickness : 250.00 mm  
Max. Cross head  
Travel : 250.00 mm  
Peak Load : 31.45 KN.  
Cross head Travel  
at Peak : 2.20 mm  
Transverse strength :  $05.87 \text{ N/mm}^2$



**Transverse Test Report is as under:**

4) Machine Model : TUE-C-1000.  
Machine Serial No. : 2009/50  
File name : A4, CIVIL, UTM.  
Material Type : RCC Beam 4  
Distance between  
Support : 420.00 mm  
Width : 150.00 mm  
Thickness : 250.00 mm  
Max. Cross head  
Travel : 250.00 mm  
Peak Load : 31.45 KN.  
Cross head Travel  
at Peak : 2.20 mm  
Transverse strength :  $05.87 \text{ N/mm}^2$



## V. CONCLUSION

We found from study that pre stress concrete anchoring devices influencing greatly to the civil engineering . As involved various process of pre stressed concrete help us very much in understanding the mechanism of the working system & various tools are available to performing for structures called anchoring devices, Further we knew that structures by pre stress are more reliable, strong & reduced in size as compared to RCC . Hence we can say that by using anchoring devices better concrete structures can be made. Also pre stress beam can take more load that is taken by RCC beam. It is one of the simple method for anchoring the beam at cheaper rate.

## VI. RECOMMENDATIONS

As we knew about the methods of pre stressing i.e. pre & post tensioning systems are better effective in their respective fields but the post-tensioning system has less loss then the other system of pre-tensioning in pre stressing. The reliability and accuracy of anchoring device meet the requirement of design & specifications.

## REFERENCES

- [1] Dolan, Charles W(1990), "Developments in Non metallic Pre-stressing Tendons" PCI – Journal Volume 35 No.5 pp80-88.
- [2] Dr. B. C. Punmia, A. K. Jain and Arun K. Jain (2012) "RCC.Designs" Laxmi Publication (P) Ltd., New Delhi, 10th Edition, (April 2012 Reprint).
- [3] Erki, M. A, and Rizkalla, S. H.(1993) "Anchorages for FRP Reinforcement", Concrete International, V15 NO.6, pp54-59.
- [4] Holte, L. E., Dolan CW and Schmidt, RJ(1993),"Epoxy Sockted Anchors for Non metallic Pre-stressing Tendons, " Proceedings, International Symposium on FRP

## AUTHORS

**First Author** – Pradeep Nath Mathur, HoD Apex Group of Institutions, Jaipur.

**Second Author** – Prof.(Dr.) A. K. Sinha, Director & H.O.D. Civil Engg. Suresh Gyan Vihar University, Jaipur

# The Association between Genetic Variation of Interferon Gamma +874 T/A and Plasma Interferon Gamma Level in Pulmonary Tuberculosis

Erwin Arief\*, Muh. Nasrum Massi\*\*, Irawaty Djaharuddin\*, Budu Mannulusi\*\*, Eliana Muis\*\*\*, Suwarti Rantono\*\*\*

\*Department of Pulmonology, Medical Faculty – Hasanuddin University

\*\*Biomedic Program, Medical Faculty – Hasanuddin University

\*\*\*Department of Internal Medicine, Medical Faculty – Hasanuddin University  
Makassar

**Abstract.** These days, *Mycobacterium tuberculosis* (Mtb) bacil is estimated to have infected one third of the world's population. World Health Organization (WHO) data shows that in 2011 there were 8.7 million case of tuberculosis (TB) or equivalent to 125 cases per 100.000 of the world's population. Some studies have been done to understand the role of certain genes toward the susceptibility of TB patients, most of those studies focused on genes that are involved in signal pathway of interferon gamma (IFN- $\gamma$ ). Interferon gamma is one of the cytokine that has a role in pathogenesis of pulmonary tuberculosis. Single nucleotide polymorphism of IFN- $\gamma$  at +874 T/A position in the first intron is reported to have association with pulmonary TB in different population. The aim of this study is to investigate the genetic variation of IFN- $\gamma$  in +874 T/A and its relation with IFN- $\gamma$  plasma level in pulmonary tuberculosis patients. The study's method is cross sectional. Blood sample was taken from the veins of new AFB (Acid-Fast Bacillus) positive tuberculosis patients. Purification examination of Deoxyribonucleic Acid (DNA) and Polymerase Chain Reaction-Restriction Fragment Length Polymorphism (PCR-RFLP) for determining the genotype of IFN- $\gamma$  genes and the level of IFN- $\gamma$  is measured using Enzyme Linked Analysis Techniques Immunosorbent Assay (ELISA). The data is presented using tables and pictures. There is a significant association between IFN- $\gamma$  +874T/A genetic variations with the plasma level of IFN- $\gamma$ . There is a domination of IFN- $\gamma$  +874T/A heterozygote genotype found in pulmonary TB population with positive +1of AFB and far advanced lesion on chest x-ray.

**Key word:** IFN- $\gamma$ , pulmonary TB, genetic variation

## I. INTRODUCTION

Tuberculosis (TB) is an infectious disease that is caused by *Mycobacterium tuberculosis* (Mtb) bacillus complex, in human, mostly caused by Mtb species. This disease often invades lungs (pulmonary TB), but it also can invade other organs (extrapulmonary TB) (WHO, 2013).

Since a few decades ago, pulmonary TB has gained a lot of attention from medical experts. This is the result of the yearly increase prevalence of the disease. Pulmonary tuberculosis patients can be cured if handled from the outset and carefully. In 2012, it is estimated that the global incidence of TB was 8.6 million (ratio 122 : 100,000 per year) and mortality 1.3 million. From these numbers, there were 50,000 cases of Multidrug Resistance-Tuberculosis (MDR-TB) and 170,000 mortality rate from MDR-TB. Most of the case of global TB happens in South-East Asia and West Pacific totaling 58%, Africa 27% (ratio 255 : 100.000 per year), India 26%, China 12%, Eastern Mediterranean 8%, Europe 4%, and America 3%. The lowest incidence ratio is mostly found in developed country such as Western Europe, Canada, USA, Japan, Australia, and New Zealand. Whereas in South Africa and Swaziland, incidence ratio of TB is 1000 : 100.000 per year (WHO, 2013). In 2013, TB incidence in Indonesia was 327.094 with 80.99% being new positive AFB pulmonary TB. The biggest proportion of AFB positive pulmonary TB (21.40%) is found in productive adult age group (25-34 years old) (Indonesia Ministry of Health, 2014).

Pulmonary tuberculosis is caused by positive gram bacillus, *Mycobacterium tuberculosis*. Mtb genome measured 4.4 Mb (mega base) with the most Guanine (G) and Cytosine (C) content. Results from the genes mapping, it is known that there are more than 165 genes and genetic marking that can be divided into 3 groups (PDPI 2011). The main structure of Mtb cell wall is mycolic acid, complex waxes, threhalosedimycolate which is known as cord factor, and mycobacterial sulpholipids that has a role in virulence. *Mycobacterium tuberculosis* is transmitted by air particles known as droplet nuclei with 1-5 micron in diameter. Transmission occurs if droplets nuclei that contains Mtb is inhaled, later it enter the airway passage and finally end at lung alveoli (CDC, 2013; Soeroto, 2012), where Mtb will be phagocyte by phagocytic immune cell (macrophage and dendrite cells) (Ahmad, 2011; Mortaz, 2012). The

inflammation process will activate T helper-1 cell (Th1). One of the cytokine that is produced by Th1 cell is IFN- $\gamma$ , which has an important role in eliminating Mtb bacillus. Interferon gamma strengthens the phagocyte potential from Mtb-infected macrophage by stimulating the formation of phagolysosome. Interferon gamma also stimulates the formation of free radical to destroy the bacillus Mtb component, DNA and cell wall (Kumar, 2005).

The importance of IFN- $\gamma$  in immune response towards micobacteria has been shown by the increase of susceptibility, the severity of disease, and poor prognosis in individual with the defect in IFN- $\gamma$ , subunit receptor of IFN- $\gamma$ , and STAT-1, either genetically or acquired, which in all is component of IFN- $\gamma$  cytokine path (Ottenhoff, 2002). The result of the study also shows that the genetic variation of IFN- $\gamma$  genes influence the production of IFN- $\gamma$  by T-cell cluster differentiated-4+ (CD4+) as well as cluster differentiated-8+ (CD8+). Homozygote T/T, A/A and heterozygote T/A each linked with the production of high, low and moderate IFN- $\gamma$  (Pravica, 2000; Lopez, 2003).

Disturbance or decrease in the activity of Th1 cell and its cytokine, IFN- $\gamma$ , has a meaningful role in influencing the mechanism of body defense mechanism against tuberculosis. Therefore, the information about the role of IFN- $\gamma$  in body defense mechanism against pulmonary tuberculosis is very important.

## II. IDENTIFY, RESEARCH AND COLLECT IDEA

### METHOD

This study uses draft research cross sectional. Sample used is the plasma of pulmonary tuberculosis patients in Makassar, South Sulawesi, that are measured using purification technique Deoxyribonucleic Acid (DNA) and Polymerase Chain Reaction-Restriction Fragment Length Polymorphism (PCR-RFLP) to determine the genotype of IFN- $\gamma$  and Enzyme Linked Immunosorbent Assay (ELISA) examination to measure the plasma level of IFN- $\gamma$ . Data is presented in tables and figures.

#### Sample Selection Method

Selection of the study subject uses accidental sampling method. Accidental sampling is the unplanned method of study subject selection, the patients that come for treatment within certain period and meet certain criteria were asked to be the subject. Period and criteria of this study is new case that has been diagnosed with positive AFB pulmonary tuberculosis who come in during September – December 2014 in Makassar.

#### Examination Procedure of IFN- $\gamma$ Level Using ELISA Kit

5 ml of the subject's venous blood was taken and put inside non-EDTA tube. The tube then centrifuged in 5000 rpm for 30 minutes. The blood that has been centrifuged will separate as erythrocyte, buffy coat layer, and blood plasma. Plasma then separated and stored in microtube. Later it was wrapped using parafilm, where it stored in the refrigerator in -80°C until it was used.

Blood plasma and ELISA kit then put in room temperature. Dissolving Lyophilized IFN- $\gamma$  Standard and Assay Diluent made standard solution. The standard solution later examined using duplo, while the other well filled with the sample that was added

with Assay Diluent first. Every well then added with Rabbit anti-Human IFN- $\gamma$  Pclyclonal Antibody. The plate then closed with sealer (Acetate Plate Sealer) to prevent evaporation and incubated in room temperature for 3 hours.

After incubation, the sealer was opened and the plate then washed using Wash Buffer. Goat anti-Rabbit Conjugated Alkaline Phosphates then added to each well and resealed, later incubated in room temperature for 45 minutes. Sealer then opened and the fluid discarded, after that the plate washed using Wash Buffer. Coloring reagent then added and incubated in room temperature for 6 minutes, afterwards the stop solution is added. The result was read using ELISA reader so that we could find the IFN- $\gamma$  level.

#### Data Analysis

The gathered data is presented in tables and figures with description provided.

## III. WRITE DOWN YOUR STUDIES AND FINDINGS

### RESULT

This study used 62 subjects of new positive AFB pulmonary TB patients who has had their +874 T/A IFN- $\gamma$  gen genetic variation and IFN- $\gamma$  plasma level examined when the diagnosed was made. From the 62 subjects, the youngest is 17 years old and the oldest is 65 year old, with mean age of 36.5 $\pm$ 14.5 years old. Almost 75% of pulmonary TB patients are in <50 years old age group.

Most of the pulmonary TB patients in this study come from age group of 16-29 years old. Most of the genetic variation of +874 T/A IFN- $\gamma$  in our pulmonary TB population heterozygote TA (32 subject or 51,6%) and the lowest is wild type homozygote TT (4 subjects or 6,5%). Distribution of subject's +874 T/A IFN- $\gamma$  gen genetic variation based on age group is presented in table 1.

Table 1. Distribution of +874 T/A IFN- $\gamma$  gen genetic variation based on age group

Genetic Variation	Age Group			Total
	16-29 n (%)	30-49 n (%)	50-65 n (%)	
AA	8 (12,9)	10 (16,1)	3 (4,8)	21 (33,9)
TA	12 (19,4)	10 (16,1)	10 (16,1)	32 (51,6)
TT	1 (1,6)	1 (1,6)	2 (3,2)	4 (6,5)
TA/TT	3 (4,8)	1 (1,6)	1 (1,6)	5 (8,1)
Total	24 (38,7)	22 (35,5)	16 (25,8)	62 (100,0)

In this study, the most of the male's genetic variation of +874 T/A IFN- $\gamma$  found is the TA genotype (32,3%) and the least is TT genotype (3,2%), the same result also found in woman where +874 T/A IFN- $\gamma$  gen genetic variation found the most is TA genotype (19,4%) and the least is TT genotype (3,2%). The distribution of subject's +874 IFN- $\gamma$  gen genetic variation based on gender is presented in table 2.

Table 2. Distribution of +874 T/A IFN- $\gamma$  gen genetic variation based on gender

Genetic Variation	Gender		Total
	Male	Female	
AA	16 (19,4)	9 (14,5)	21 (33,9)



TA	20 (32,3)	12 (19,4)	32 (51,6)
TT	2 (3,2)	2 (3,2)	4 (6,5)
TA/TT	3 (4,8)	2 (3,2)	5 (8,1)
Total	37 (59,7)	25 (40,3)	62 (100)

Toward all 62 subjects after the diagnosis of pulmonary TB was enforced, the IFN- $\gamma$  level examination was executed. Obtained the average of  $22,13 \pm 22,33$  pg/mL, with the lowest level in 6.25 pg/mL and the highest 112.97 pg/mL.

To understand the relation between +874 T/AIFN- $\gamma$  gen genetic variation and IFN- $\gamma$  plasma level, we use the Spearman nonparametric correlation test considering the abnormal distribution of IFN- $\gamma$  plasma level. The result of Spearman correlation test shows that there is a significant correlation between +874 T/A IFN- $\gamma$  gen genetic variation and IFN- $\gamma$  plasma level with  $p=0.001$  ( $p<0.01$ ). (figure 1)

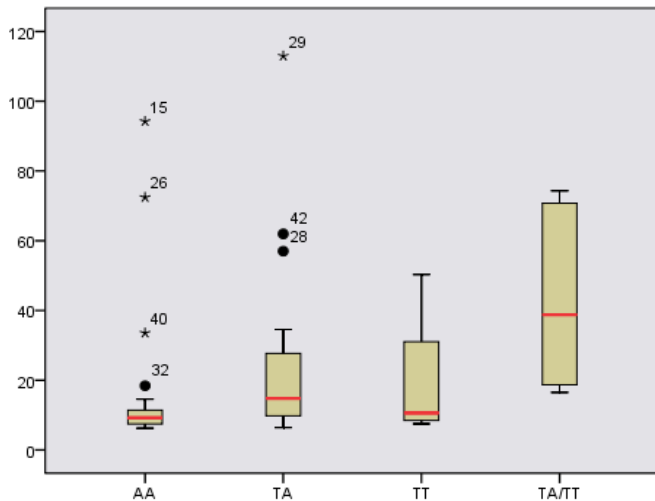


Figure 1. IFN- $\gamma$  plasma level (phase 0) based on +874 T/A IFN- $\gamma$  gen genetic variation. Red line shows the median of IFN- $\gamma$  level in each genotype. Spearman correlation test,  $p<0.01$ .

The AFB level in sputum test and the lesion area in chest x-ray can determine the severity of pulmonary TB. In this study based on the lesion area, the most common to find is far advanced lesion (48.4%). The most genetic variation of +874 T/A IFN- $\gamma$  gen found in pulmonary TB patients with broad lesion is TA genotype (29.0%) and the least is TT genotype (0.0%). The distribution of +874 T/A IFN- $\gamma$  gen genetic variation based on lesion area in chest x-ray is presented in table 3.

Table 3. Distribution of +874 T/A IFN- $\gamma$  gen genetic variation based on lesion area in chest x-ray

Genetic Variation	Degree of Lesion in Chest X-ray			Total
	Minimal	Moderate	Far advanced	
AA	3 (4,8)	8 (12,9)	10 (16,1)	21 (33,9)
TA	5 (8,1)	9 (14,5)	18 (29,0)	32 (51,6)
TT	2 (3,2)	2 (3,2)	0 (0,0)	4 (6,5)
TA/TT	0 (0,0)	3 (4,8)	2 (3,2)	5 (8,1)
Total	10 (16,1)	22 (35,5)	30 (48,4)	62 (100,0)

Based on the positivity of AFB sputum test, in this study, the most common to find is AFB positive one (59.7%). Genetic variation of +874 T/A IFN- $\gamma$  gen found the most in the subject with AFB positive one is TA genotype (33.9%), and the least is TA/TT genotype (1.6%). Distribution of +874 T/A IFN- $\gamma$  gen genetic variation based on positivity of AFB sputum test is presented in table 4.

Table 4. Distribution of +874 T/A IFN- $\gamma$  gen genetic variation based on positivity of AFB sputum test

Genetic Variation	AFB Sputum Test			Total
	+1	+2	+3	
AA	13 (21,0)	5 (8,1)	3 (4,8)	21 (33,9)
TA	21 (33,9)	5 (8,1)	6 (9,7)	32 (51,6)
TT	2 (3,2)	1 (1,6)	1 (1,6)	4 (6,5)
TA/TT	1 (1,6)	0 (0,0)	4 (6,5)	5 (8,1)
Total	37 (59,7)	11 (17,1)	14 (22,6)	62 (100,0)

#### IV. GET PEER REVIEWED

Interaction of human against Mtb infection is determined by environmental factor, the pathogen, and genetic factors, also the interaction between the three. Control over Mtb infection in the body requires the formation of T antigen-specific cells response, Mtb infected macrophage activation, and the formation of granuloma to prevent the spreading of Mtb bacillus. Macrophages that are activated by IFN- $\gamma$  are very important for immunity against Mtb, thereby the shortcoming of one of the component in IFN- $\gamma$  signal path will cause susceptibility to TB. This study is focused in IFN- $\gamma$ , because even though the activation of immune response mediated by IFN- $\gamma$  has an important role in immunity against intracellular pathogen either on human or animal, its role in tuberculosis in human has not fully understand yet.

The genetic variation in single nucleotide gen that encode the cytokines variedly correspond with TB infection location and the degree of severity of this disease in different population as well as in the same study population. Some studies about the correlation between genetic variation of IFN- $\gamma$  +874 T/A gen and the severity of pulmonary TB has been done by Vallinoto et al (2010), Etokebe et al (2006), Henao et al (2006), Ansari et al (2011).

#### V. IMPROVEMENT AS PER REVIEWER COMMENTS

This study aims to investigate the role of IFN- $\gamma$  +874 T/A gen polymorphism and IFN- $\gamma$  plasma level with the severity of pulmonary Tb patients based on the positivity of AFB sputum test and lesion area in chest x-ray.

In this study, the most genetic variation of IFN- $\gamma$  +874 T/A gen that was found is TA genotypes, namely 51.6% and 32.3%, are male. Etokebe study (2006) also finds that the group with TA

genotype is the group with the highest frequency of genetic namely 50.4%, different result found in Vallinoto study (2010) that has AA genotype group namely 56,6%, as well as Hwang (2007) who also found similar major genotype frequency that is AA group namely 82.5%. The relation between the susceptibility of TB and IFN- $\gamma$  polymorphisms has been observed inside different population. (Lopez, 2003; Etokobe, 2006)

This study finds that there is a significant correlation between IFN- $\gamma$  +874 T/A gene genetic variation with IFN- $\gamma$  plasma level ( $p=0.001$ ). Pravica, et al (2000) shows that genetic variation of single nucleotide (T $\rightarrow$ A) in +874 position at first intron from IFN- $\gamma$  gen influence the production of IFN- $\gamma$ , possibly caused by the +874 position is the are that responsible for NF- $\kappa$ B factor transcription. The correlation between genetic variation of IFN- $\gamma$  +874 T/A and ex-vivo production of IFN- $\gamma$  by peripheral mononuclear cells in Lopez study (2003) indicates that the linkage with functional variants in other locus in that gen regulation area. The specific bond of NF- $\kappa$ B to the DNA order that contains +874 alleles causes functional consequence towards IFN- $\gamma$  gene's transcription and its production (Heinemeyer, 1998; Pravica, 1999). Study conducted by Vallinoto et al (2010) shows that tuberculosis patients with +874 A/A genotype show profound low IFN- $\gamma$  plasma level compared to patients with +874 T/A and +874 T/T genotype, which can be strong evidence that the polymorphisms decreases the production of IFN- $\gamma$  and cellular immunity activation that can increase the possibility of infection.

Genetic variation based on lesion area found the most in this study is far advanced lesion with TA genotype as the group with highest genetic frequency namely 29,0%, different result found in a study by Lopez (2003) where the most patients are patients with moderate lesion and AA genotype.

Analysis of genetic variation of IFN- $\gamma$  +874 T/A towards subjects in this study shows that from the four genotype types, homozygous +874 T/A constituting the most genotype (51.6%). Polymorphisms of IFN- $\gamma$  +874 has shown to have meaningful correlation with tuberculosis. Studies by Lopez et al (2003) and Pravica et al (2000) found that frequency of allele A is high in pulmonary TB patients and control with TST (+) and TST (-) compared with miliary tuberculosis patients and pleural TB, whereas allele T that connects with the IFN- $\gamma$  production that is high in-vitro, increases in patients with miliary and pleural TB. Vallinoto et al (2010) shows that there is a correlation between allele +874 A and active TB, at the same times shows a high frequency of allele +874 T in control group. These results show the protective role of allele +874 T, on the other hand, allele +874 A is the predisposition factor of Mtb infection. The result of these studies strengthen the correlation between genotype

+874 AA with the susceptibility towards bacteria, whereas genotype +874 T/T may have connected with the protection against Mtb infection, or even the partial protection if allele T shows in heterozygote.

The expression and production of IFN- $\gamma$  is regulated genetically, study by Lopez et al (2003) shows that this polymorphisms influence the production of IFN- $\gamma$  induced by PPD in TB patients, healthy contact, or normal subject. The lowest production of IFN- $\gamma$  found in AA genotype both before and after therapy. Production of IFN- $\gamma$  with genotype AA is twice as low compared with the other two genotype (TA and TT) and still low even after 6 month post treatment even compared to control. Settlement of low IFN- $\gamma$  production by peripheral mononuclear cell more than 6 months show that there is a genetic defect in the production of IFN- $\gamma$  in the patients with homozygote allele A that become the basis of the increase of reactivation ratio from one latent tuberculosis focus. Statistic analysis also shows that the presence of AA genotype and lymphocyte count is the independent predictor toward the production of IFN- $\gamma$ .

In our study, the most commonly genetic variation found in patients with AFB sputum test result of positive 3 is genotype TA. This is in accordance with the study of Etokobe et al (2006), in tuberculosis patients with positive AFB sputum test result the most commonly found genotype group is TA, but it is said to not have any influence toward the severity of the disease.

**After submission IJSRP will send you reviewer comment within 10-15 days of submission and you can send us the updated paper within a week for publishing.**

This completes the entire process required for widespread of research work on open front. Generally all International Journals are governed by an Intellectual body and they select the most suitable paper for publishing after a thorough analysis of submitted paper. Selected paper get published (online and printed) in their periodicals and get indexed by number of sources.

## VI. CONCLUSION

This study shows that there is an association between genetic variations of IFN- $\gamma$  +874T/A with the level of plasma IFN- $\gamma$ . There is a domination of heterozygote +874T/A genotype found in pulmonary TB patients with AFB sputum test positive one and far advanced lesion on chest x-ray.

## REFERENCES

- Ahmad, S. 2011. Pathogenesis, immunology, and diagnosis of latent mycobacterium tuberculosis infection. *ClinDevImmunol*, vol. 2011, 814943. <http://www.hindawi.com/journals/jir/2011/814943.pdf>. 10 Juli 2014.
- Ansari A, Hasan Z, Dawood G, et al. 2011. Differential combination of cytokine and interferon- $\gamma$  +874 T/A polymorphisms determines disease severity in pulmonary tuberculosis. *Plos One*; 6:11
- Centers for Disease Control and Prevention. 2013. *The core curriculum on tuberculosis: what the clinician should know*, (6th ed., p. 19-105). Centers for Disease Control and Prevention
- Etokebe, G.E., Bulat-Kardum, L., Johansen, M.S., Knezevic, J., Balen, S., et al. 2006. Interferon- $\gamma$  gene (T874A and G2109A) polymorphisms are associated with microscopy-positive tuberculosis. *Scand J Immunol*;63 (2), 136–41.
- Heinemeyer T, Wingender E, Reuter I, Hermjakob H, Kel AE, Kel OV, Ignatieva EV, Ananko EA, Podkolodnaya OA, Kolpakov FA, et al. 1998. Databases on transcriptional regulation: TRANSFAC, TRRD and COMPEL. *Nucleic Acids Res*;26:362–367.
- Henaio, M.I., Montes, C., Paris, S.C., Garcia, L.F. 2006. Cytokine gene polymorphisms in Colombian patients with different clinical presentations of tuberculosis. *Tuberculosis (Edinb)*;86 (1), 11–19.
- Hwang, J.H., Kim, E.J., Kim, S.Y., Lee, S.H., Suh, G.Y., et al. 2007. Polymorphisms of interferon- $\gamma$  and interferon- $\gamma$  receptor 1 genes and pulmonary tuberculosis in Koreans. *Respirology*;12 (6), 906–10.
- Indonesia Ministry of Health. 2014. Data and Information of Indonesia Health Profile in 2013, (p. 138-140). Jakarta: Indonesia Ministry of Health
- Kumar V, Abbas AK, Fausto N. Pathologic Basis of Disease. Philadelphia: Elsevier Saunders 2005.
- Lopez-Maderuelo D, Arnalich F, Serantes R, et al. 2003. Interferon gamma and interleukin-10 gene polymorphisms in pulmonary tuberculosis. *Am J Respir Crit Care Med* ;167:970–5
- Mortaz, E., Varahram, M., Farnia, P., Bahadori, M., Masjedi, M.R. 2012. New aspects in immunopathology of Mycobacterium tuberculosis. *ISRN Immunol*, vol. 2012, 963879. <http://www.hindawi.com/journals/isrn-immunology/2012/963879.pdf>. 10 Juli 2014.
- Ottenhoff, T.H., Verreck, F.A., Lichtenauer-Kaligis, E.G., Hoeve, M.A., Sanal, O., et al. 2002. Genetics, cytokines and human infectious diseases: lessons from weakly pathogenic mycobacteria and salmonellae. *Nat Genet*, 32 (1), 97-105.
- Indonesia Society of Respiriology (PDPI). 2011. *Tuberculosis: Diagnosis and Treatment Guidelines in Indonesia*. Jakarta: Perhimpunan Dokter Paru Indonesia. <http://www.klikpdpi.com/konsensus/tb/tb.html>. 10 Juli 2014.
- Pravica, V., Asderakis, A., Perrey, C., Hajeer, A., Sinnott, P.J., et al. 1999. In vitro production of IFN-gamma correlates with CA repeat polymorphism in the human IFN-gamma gene. *Eur J Immunogenet*, 26 (1), 1-3.
- Pravica, V., Perrey, C., Stevens, A., Lee, J.H., Hutchinson, I.V. 2000. A single nucleotide polymorphism in the first intron of the human IFN-gamma gene: absolute correlation with apolymorphic CA microsatellite marker of high IFN-gamma production. *Hum Immunol*, 61 (9), 863-66.
- Soeroto, A.Y. 2012. Tuberculosis. In: Dahlan, Z., Amin, Z., Soeroto, A.Y., (Eds.). *Kompedium tatalaksana penyakit respirasi dan kritis paru*, (jilid 1., p. 129-141). Bandung: Perhimpunan Respirologi Indonesia (PERPARI).
- Vallinoto ACR, Graca ES, Araujo MS, et al. IFNG-874T/A polymorphism and cytokine plasma levels are associated with susceptibility to mycobacterium tuberculosis infection and clinical manifestation of tuberculosis. *Human Immunology* 2010; 71: 692-96
- World Health Organization. 2013. The burden of disease caused by TB. In: *Global tuberculosis report 2013*, (p. 6-27). France: World Health Organization.
- Ahmad, S. 2011. Pathogenesis, immunology, and diagnosis of latent mycobacterium tuberculosis infection. *Clin Dev Immunol*, vol. 2011, 814943. <http://www.hindawi.com/journals/jir/2011/814943.pdf>. 10 Juli 2014.
- Centers for Disease Control and Prevention. 2013. *The core curriculum on tuberculosis: what the clinician should know*, (6th ed., p. 19-105). Centers for Disease Control and Prevention.
- Indonesia Society of Respiriology (PDPI). 2011. *Tuberculosis: Diagnosis and Treatment Guidelines in Indonesia*. Jakarta: Perhimpunan Dokter Paru Indonesia. <http://www.klikpdpi.com/konsensus/tb/tb.html>. 10 Juli 2014.
- Mortaz, E., Varahram, M., Farnia, P., Bahadori, M., Masjedi, M.R. 2012. New aspects in immunopathology of Mycobacterium tuberculosis. *ISRN Immunol*, vol. 2012, 963879. <http://www.hindawi.com/journals/isrn-immunology/2012/963879.pdf>. 10 Juli 2014.
- Soeroto, A.Y. 2012. Tuberculosis. In: Dahlan, Z., Amin, Z., Soeroto, A.Y., (Eds.). *Kompedium tatalaksana penyakit respirasi dan kritis paru*, (jilid 1., p. 129-141). Bandung: Perhimpunan Respirologi Indonesia (PERPARI).
- World Health Organization. 2013. The burden of disease caused by TB. In: *Global tuberculosis report 2013*, (p. 6-27). France: World Health Organization.

## AUTHORS

**First Author** – Erwin Arief, Department of Pulmonology, Medical Faculty Hasanuddin University, Indonesia, [erwin.pulmo@gmail.com](mailto:erwin.pulmo@gmail.com)

**Second Author** – Muh. Nasrum Massi, Biomedic Program, Medical Faculty Hasanuddin University, Indonesia, [nasrumm2000@yahoo.com](mailto:nasrumm2000@yahoo.com)

**Third Author** – Irawaty Djaharuddin, Department of Pulmonology, Medical Faculty Hasanuddin University, Indonesia, [irawatymuzakkir@gmail.com](mailto:irawatymuzakkir@gmail.com)

**Correspondence Author** – Eliana Muis, [elianamuis@gmail.com](mailto:elianamuis@gmail.com), [pulmonologi.fkuh@gmail.com](mailto:pulmonologi.fkuh@gmail.com), +62411582002.

# Carcinoembryonic antigen, C-reactive protein and albumin as prognostic indicators in colorectal carcinomas

**Dr. Rajesh Nair, MS, Senior Resident\***, **Dr. Bhavna Nayal, MD, Assistant Professor\*\***, **B H Anand Rao, Professor, Department of Surgery\*\*\***

\*Dept of General Surgery, Kasturbe Medical Collge (KMC), Manipal University, Manipal

\*\*Dept of Pathology, KMC, Manipal University, Manipal

## I. INTRODUCTION

Colorectal carcinoma is the most common malignancy of the gastrointestinal tract and the second leading cause of cancer deaths. Five-year survival rate in patients with localized disease is 94%.<sup>1</sup>

Early detection and subsequent prompt treatment of colorectal carcinomas provide a better five years survival rate. Higher detection rate can be achieved if patients over 40 years of age with symptoms are submitted to a series of investigations including sigmoidoscopy, barium enema and colonoscopy. Colon cancer screening not only detects the disease at an early, more favorable stage, but also prevents disease by removing premalignant polyps.<sup>2</sup>

Since the discovery of CEA in 1965, various other substances have been found to be of some significance in colorectal cancers, most notably acute phase reactants, namely C-reactive protein, Alpha 1 antitrypsin, etc. The prognostic value and repeatability of these markers are being studied.<sup>3</sup>

C- Reactive Protein (CRP) as proven, is a marker of chronic inflammation. And it is commonly used to evaluate systemic inflammatory response.<sup>4</sup> It has an annular pentameric structure and is synthesized in the liver. It is a non specific acute phase reactant, which has been reported to be a prognostic factor for colorectal carcinoma.<sup>5</sup>

It has been hypothesised that cancer originated at sites of chronic inflammation.<sup>6</sup> Chronic inflammation leads to cell proliferation and in turn to irreversible DNA damage. The presence of low-grade systemic inflammation, as determined by an elevation of high-sensitivity C-reactive protein (CRP), has been associated with an increased risk of cancers.

Pre-treatment serum albumin concentrations have been shown to be an independent prognostic factor in a number of malignant diseases. However, the role of albumin as an independent prognostic indicator in patients with localized, non-metastatic colorectal cancer has not, as yet, been adequately documented.

Colorectal cancer is responsible for approximately 15% of all cancer deaths,<sup>7</sup> and the corrected 5-year survival is less than 50%.<sup>8</sup>

This study was undertaken to determine the significance of C-Reactive protein (CRP), Carcinoembryonic antigen (CEA) and albumin levels in colorectal carcinomas (CRC).

## II. MATERIALS AND METHODS

All patients who underwent surgical treatment for colorectal carcinomas, admitted to the surgical wards of Kasturba Hospital, Manipal.

### Study period

January 2009 to July 2011.

### Inclusion criteria

All histologically proven cases of colorectal malignancies in any age group and both sexes.

### Exclusion criteria

Patients subjected to non curative treatment. Patients with fever, arthritis, inflammatory bowel disease, uremia. Emergency surgeries.

### Study design

Cross sectional study conducted between the period of January 2009 to July 2011.

Preoperative CRP, CEA and albumin were assessed.

Further CRP, CEA and albumin assessment will be done during 1<sup>st</sup> (3<sup>rd</sup> to 5<sup>th</sup> week postoperatively) and 2<sup>nd</sup> (3<sup>rd</sup> to 6<sup>th</sup> month postoperatively) follow up visits.

### Method of CRP, CEA and albumin determination

CRP, CEA and Albumin will be estimated in biochemistry laboratory using agglutination reaction and reviewed from the patient records.

CEA levels >4ng/ml was taken as positive (Yu-chen shiu et al, 2001).<sup>27</sup>

CRP levels of >6ng/dl was taken as significant (Yu-chen shiu et al, 2001).<sup>27</sup>

Albumin level <3.5g/ml was taken as hypoalbuminemia (Heys et al, 1998).<sup>28</sup>

## III. OBSERVATIONS AND ANALYSIS

A total of 69 patients with colorectal carcinoma were studied.

**Age distribution of colorectal carcinomas (n = 69)**

Out of the 69 patients diagnosed to have colorectal carcinomas, 41(59.4%) patients were below 60 years of age and 28(40.6%) patients were above 60 years. Mean age at presentation was 55.6 years. The youngest patient diagnosed was 28 years old while the oldest was 87 years old.

Out of the 69 patients diagnosed to have colorectal carcinomas, 43(62.3%) patients were males and 26(37.7%) patients were females. Male preponderance was seen in the present study, which was in concordance with the study by Yu-Chen Shiu<sup>9</sup> et al.

Only 5 cases out of the 69 patients in our study had a family history of colorectal carcinoma.

**Location of colorectal carcinomas**

Thirty (43.4%) of the 69 patients diagnosed to have colorectal carcinomas were located in the right colon, 27(39.1%) in the left colon, 11(15.9%) in the rectum and only 1(1.4%) involved both the left and right colon. The most common location of colorectal carcinoma was found to be the right colon.

**Histological differentiation of colorectal carcinomas**

The most common histological differentiation of colorectal carcinoma observed was moderately differentiated type, accounting for 30(43.4%) cases followed by well differentiated, 24 (34.8 cases) and least being the poorly differentiated type, 15(21.7%) cases.

**Gross tumor size in colorectal carcinomas**

Thirty seven (53.2%) cases had tumor size of >5.2 cms while 32(46.4%) cases had tumor size of more than or equal to 5.2 cms at the time of diagnosis.

**Gross type of colorectal carcinomas**

The most common gross type observed was ulcerative type accounting for 49(71%) of the 69 cases. Twelve (12%) cases presented with polypoidal lesions and 8(17.4%) cases had infiltrative lesions.

**Distribution of colorectal carcinomas based on AJCC staging**

Most of the patients presented with stage III and stage IV disease accounting for 27(39.1%) and 20(29%) cases respectively. Eleven (15.9%) cases presented in stage I and II each.

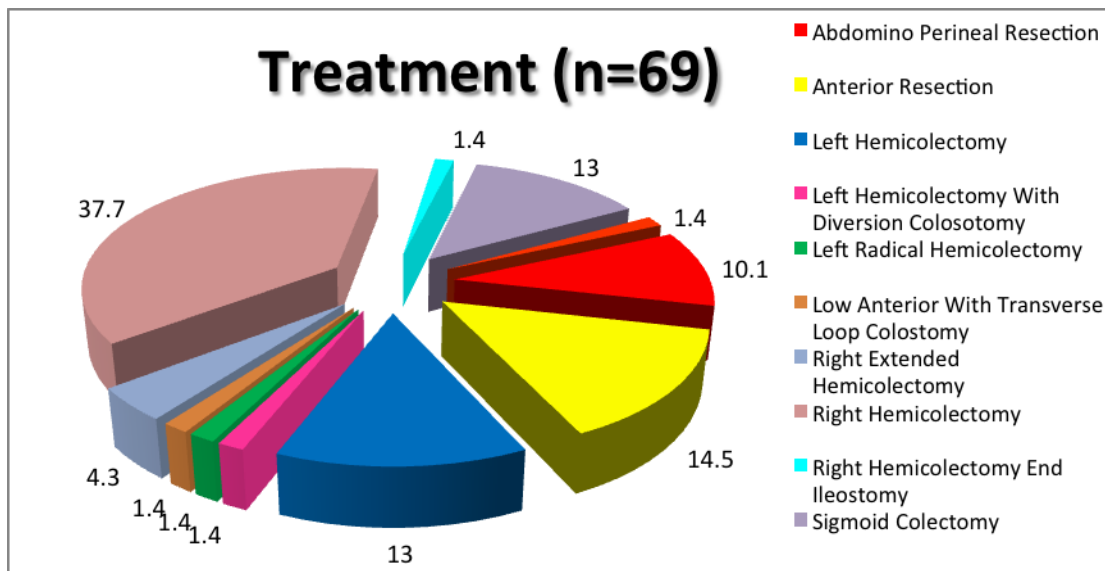
**Distribution of colorectal carcinomas based on Astler Coller staging**

Majority of the cases, 41 of 69 cases, were diagnosed to have Astler Coller stage C2 disease. Five cases had C1, 16 cases with B2 and 7 cases with B1 disease.

**Histopathological distribution of colorectal carcinomas**

The most common histo-pathological type was adenocarcinoma, accounting for 62(89.9%) of 69 cases in the study. Six (8.7%) cases had mucinous adenocarcinoma while only 1(1.4%) case had signet ring cell adenocarcinoma.

**Figure 1: Treatment modalities advocated for colorectal carcinomas**



Most common treatment advocated for the patients with colorectal carcinomas in the present study was observed to be right hemicolectomy accounting for 26(37.7%) cases, as the most common location for these tumors was right colon.



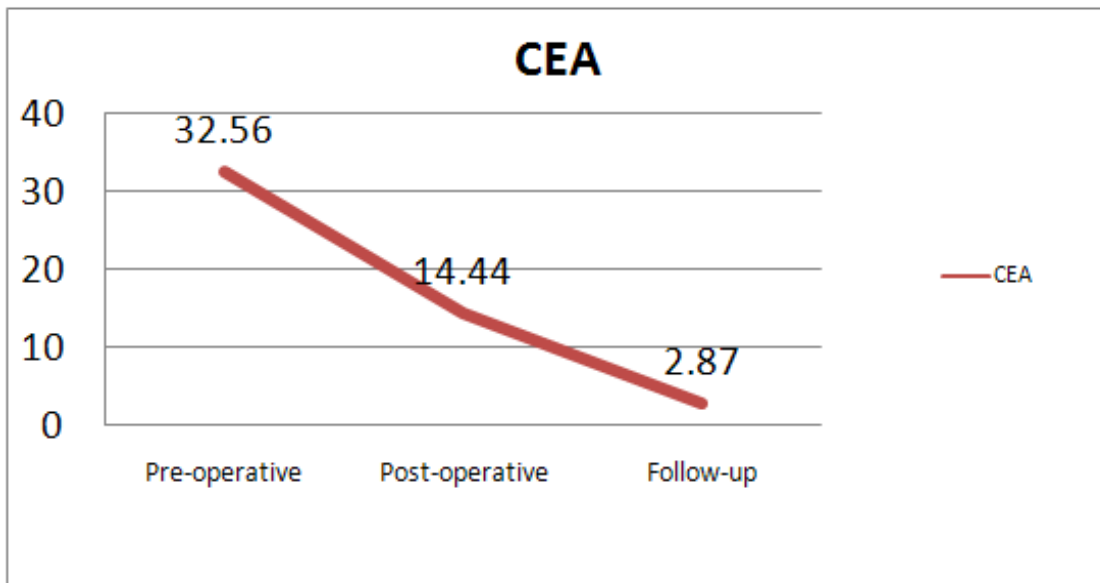
**Table 1: Association of mean preoperative, postoperative and followup CEA levels in colorectal carcinomas**

	Mean	Standard deviation	n	p – value	Post hoc test
<b>Preoperative CEA</b>	32.56	57.64	65	<b>&lt;0.001</b>	1>2 1>3
<b>Postoperative CEA</b>	14.44	48.74	65		
<b>Followup CEA</b>	2.87	1.43	65		

Statistically significant

A statistically significant association was seen between mean preoperative, postoperative and followup CEA levels in colorectal carcinomas.

**Figure 2: Association of mean preoperative, postoperative and followup CEA levels in colorectal carcinomas**



Repeated Measures ANOVA followed by post hoc Bonferroni test was performed to assess any significant difference in CEA levels in the 3 visits. It was found that there was statistical difference in the mean CEA level at the 3 visits. However, Post hoc test showed that the mean pre-CEA was

significantly higher than the post CEA and at follow-up. No difference was seen post op and follow-up CEA levels.

No statistically significant association could be demonstrated between histopathological types of colorectal carcinomas and preoperative, postoperative and followup CEA levels.

**Table 2: Association of gross types of colorectal carcinomas and CRP levels**

Significant CRP	Gross type			p value
	Infiltrative (8)	Polypoid (12)	Ulcerative (49)	
<b>Preoperative</b>	3	5	23	<b>0.856</b>
	37.5%	41.7%	46.9%	
<b>Postoperative</b>	1	1	13	<b>0.28</b>

	12.5%	8.3%	27.7%	
<b>Followup</b>	0	1	8	<b>0.30</b>
	.0%	8.3%	21.1%	

No statistically significant association could be demonstrated between gross types of colorectal carcinomas and preoperative, postoperative and followup CEA levels.

**Table 3: Association of histopathological type of colorectal carcinomas with CRP levels**

Significant CRP	Histopathology			p value
	Adenocarcinoma (62)	Mucinous (6)	Signet cell (1) Ring	
<b>Preoperative</b>	27 43.5%	4 66.7%	0 0%	<b>0.366</b>
<b>Postoperative</b>	14 23.3%	1 16.7%	0 0%	<b>0.81</b>
<b>Followup</b>	8 15.7%	1 25%	0 0%	<b>0.81</b>

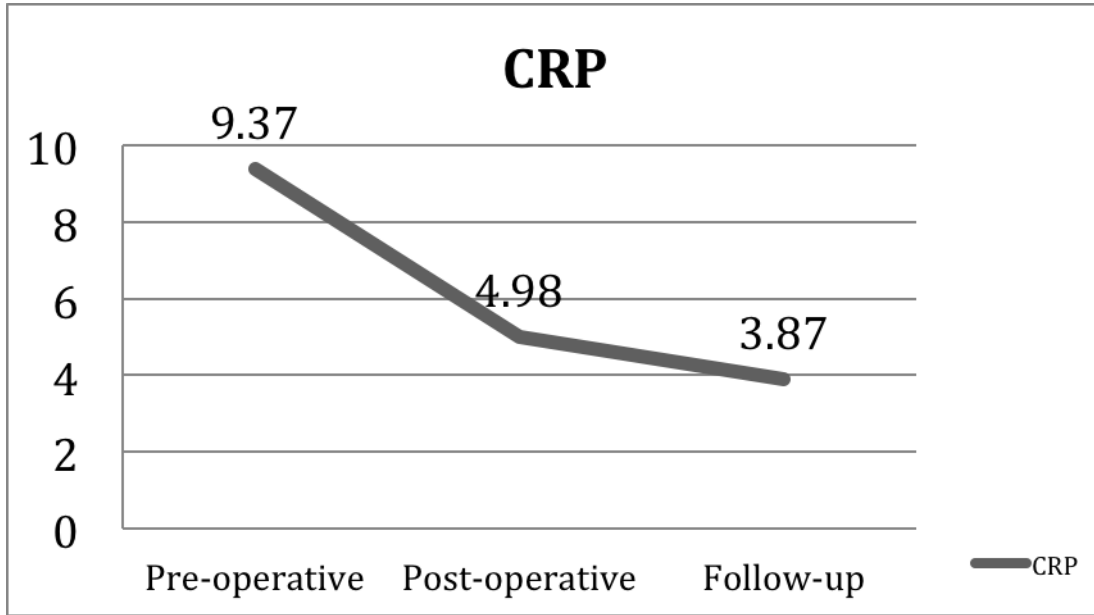
No statistically significant association could be demonstrated between histopathological types of colorectal carcinomas and preoperative, postoperative and followup CEA levels.

**Table 4: Association of mean preoperative, postoperative and followup CRP levels in colorectal carcinomas**

	Mean	Standard deviation	n	p – value	Post hoc test
<b>Preoperative CRP</b>	9.37	11.25	55	<b>&lt;0.001</b>	<b>1&gt;2&gt;3</b>
<b>Postoperative CRP</b>	4.98	5.60	55		
<b>Followup CRP</b>	3.87	4.56	55		

A statistically significant association was seen between mean preoperative, postoperative and followup CEA levels in colorectal carcinomas.

**Figure 3: Association of mean preoperative, postoperative and followup CRP levels in colorectal carcinomas**

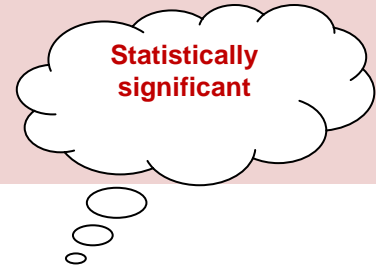


Repeated Measures ANOVA followed by post hoc Bonferroni test was performed to assess any significant difference in CRP levels in the 3 visits. It was found that there was statistical difference in the mean CRP level at the 3 visits.

Post hoc test showed that the mean preoperative CRP was significantly higher than the postoperative CRP and at follow-up. Similarly the mean CRP postoperative was significantly higher than follow-up.

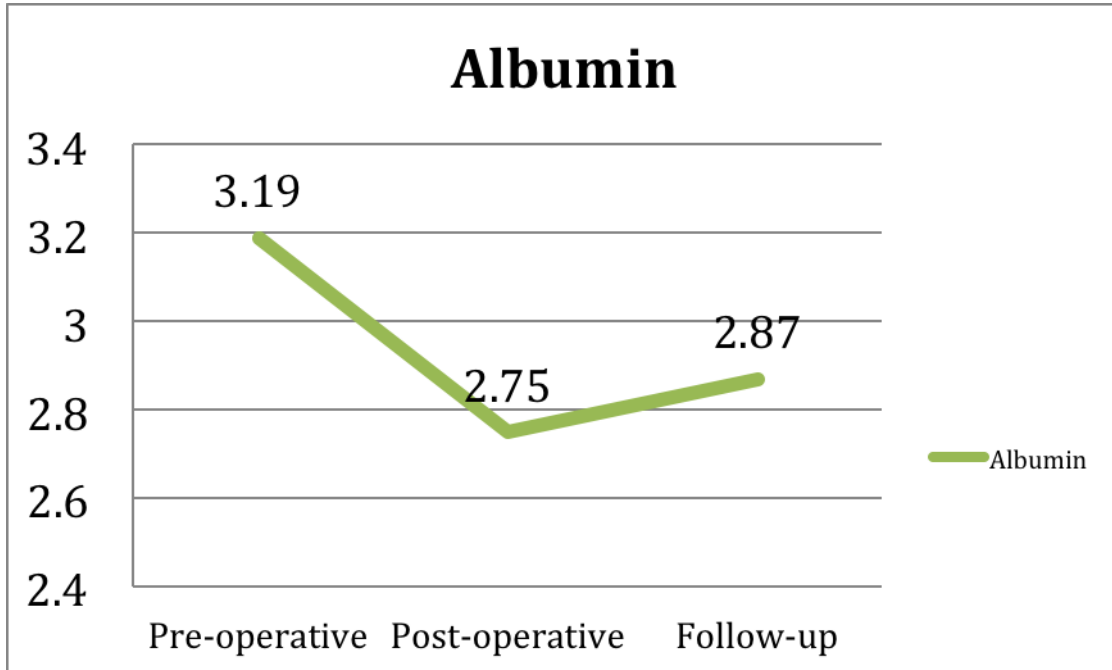
**Table 5: Association of mean, preoperative and followup albumin levels in colorectal carcinomas**

	Mean	Standard deviation	n	p – value	Post hoc test
<b>Preoperative albumin</b>	3.19	.85	66	<b>&lt;0.001</b>	<b>1&gt;2 1&gt;3</b>
<b>Postoperative albumin</b>	2.75	.74	66		
<b>Followup albumin</b>	2.87	.58	66		



A statistically significant association was seen between mean preoperative, postoperative and followup CEA levels in colorectal carcinomas.

**Figure 4: Association of mean preoperative, postoperative and followup albumin levels in colorectal carcinomas**



Repeated Measures ANOVA followed by post hoc Bonferroni test was performed to assess any significant difference in albumin levels in the 3 visits. It was found that there was statistical difference in the mean albumin level at the 3 visits. However, post hoc test showed that the mean preoperative albumin was significantly higher than the postoperative albumin and at followup. No difference was seen postoperative and followup albumin levels.

#### IV. DISCUSSION

As per a study by Holyoke et al<sup>10</sup> in 1975, it showed that 18% of the patients in Duke's Stage A disease had an elevated

prima CEA level, 53% in Stage B1, 62% in Stage B2, 65% in Stage C1 and 79% in Stage C2. This study did show that a larger percentage of patients in advanced disease state tend to have elevated CEA at the time of primary presentation however all of them did not have elevated CEA at the time of diagnosis. This is in concordance with our study.

The proportion of patients with elevated CEA level was 56.5% and 80.4% in Astler Coller B and C groups respectively as per our study. There was a significant increase in the proportion of patients with raised CEA level through the progressive stages of disease ( $P < 0.05$ ) and also there was increase in the level of CEA per se. This is in strong agreement with the data from other groups, Wanebo et al<sup>11</sup>, Goslin et al<sup>12</sup> and Janusz et al<sup>13</sup>.

**Table 6: Comparison of preoperative CEA levels in various studies.**

Study	Stage A		Stage B		Stage C	
	Total no. of patients	No. of patients with raised preoperative CEA	Total no. of patients	No. of patients with raised preoperative CEA	Total no. of patients	No. of patients with raised preoperative CEA
Wanebo et al 1978 <sup>161</sup>	58	2 (4%)	51	13 (25%)	63	28 (44%)
Robert Goslin et al 1980 <sup>49</sup>	7	-	71	11 (15%)	46	21 (46%)

<b>Janusz J. et al 1982<sup>162</sup></b>	53	13 (25%)	41	12 (30%)	127	75 (59%)
<b>Present study 2011</b>	-	-	<b>23</b>	<b>13 (56.5%)</b>	<b>46</b>	<b>37 (80.4%)</b>

The present study was compared with the study done by Yu-Chen Shiu *et al*<sup>9</sup>. According to their study, the CRP level, differentiation and gross type were the independent prognostic factors. It also showed that CRP was significant for Stage III and IV disease, but not for stage II. In the present study, 14 patients in Stage 4 disease had significant CRP preoperatively (n=20, 70%), 44.9% of the patients had positive pre-operative significant CRP levels. In the study by Yu-Chen Shiu *et al*<sup>9</sup>, CRP level was considered as an independent variable. But, in our

study, there was a positive relation of change in CRP with stage IV disease. CEA elevation along with CRP elevation had shown statistical significance in the present study. Furthermore it was concluded that though CEA alone could not be used as a prognostic tool, the combined values of CEA and CRP was a strong predictor of prognosis in colorectal carcinomas. Primary tumor size and levels of CRP showed a strong statistically significant co-relation in Yu Chen Shiu's<sup>9</sup> study which is in vehement approval of the data from the present study. (Table 7)

**Table 7: Comparison of various factors in present study with Yu-Chen *et al*<sup>9</sup>**

	Yu-Chen Shiu <i>et al</i> 2001 <sup>27</sup>				Present Study 2011				
	Patient number (%)				Patient number (%)				
	CRP<6	CRP>6	p value	CRP<6	CRP>6	p value			
<b>Age</b>	<b>&lt;60</b>	n=105 58(27.4)	47(22.2)	0.055	n=41 22 (57.9)	19(61.3)	<b>0.775</b>		
	<b>&gt;60</b>	n=107 45(21.2)	62(29.2)		n=28 16 (42.1)	12 (38.7)			
<b>Gender</b>	<b>Male</b>	n=140 66(31.3)	74(34.9)	0.56	n=43 12 (31.6)	14 (45.2)	<b>0.247</b>		
	<b>Female</b>	n=72 37(17.5)	35(16.5)		n=26 26 (68.4)	17 (54.8)			
<b>Family History</b>	<b>Negative</b>	n=192 94(44.3)	101(47.6)	0.71	n=64 35 (92.1)	29 (93.5)	<b>0.818</b>		
	<b>Positive</b>	n=17 9(4.2)	8(3.8)		n=5 3 (7.9)	2 (6.5)			
<b>Differentiation</b>	<b>Well</b>	n=2 1(0.5)	1(0.5)	0.16	n=24 15 (39.5)	9 (29)	<b>0.55</b>		
	<b>Moderate</b>	n=180 90(42.5)	90(42.5)		n=30 16 (42.1)	14 (45.1)			
	<b>Poor</b>	n=30 12(5.7)	18(8.5)		n=15 7 (18.4)	8 (25.8)			
<b>Gross type</b>	<b>Polypoid</b>	n=54 35(16.5)	19(9)	0.015	n=12 7 (18.4)	5 (16.1)	<b>0.856</b>		



	<b>Ulcerative</b>	n=143	60(28.3)	83(39.2)	n=49	26 (68.4)	23 (74.2)
	<b>Infiltrative</b>	n=15	8(3.8)	7(3.3)	n=8	5 (13.2)	3 (9.7)

	Yu-Chen Shiu et al 2001				Present Study 2011				
		Patient (%)		number	p value	Patient (%)		p value	
		CRP<6	CRP>6			CRP<6	CRP>6		
<b>Location</b>	<b>Right colon</b>	n=63	26(12.3)	37(17.5)	0.066	n=30	17 (44.7)	13 (41.9)	<b>0.367</b>
	<b>Left colon</b>	n=79	35(16.5)	44(20.8)		n=27	13 (34.2)	14 (45.2)	
	<b>Rectum</b>	n=70	42(19.8)	28(13.2)		n=11	8 (21.1)	3 (9.7)	
<b>Size (cm)</b>	<b>&lt;5.2</b>	n=103	66(31.1)	37(17.5)	<0.001	n=37	21 (55.3)	16 (51.6)	<b>&lt;0.001</b>
	<b>&gt;5.2</b>	n=109	37(17.5)	72(34)		n=32	17 (44.7)	15 (48.4)	
<b>AJCC Staging</b>	<b>Stage I</b>	n=29	22(10.4)	7(3.3)	0.002	n=11	4 (10.5)	7 (22.6)	<b>0.006</b>
	<b>Stage II</b>	n=64	32(15.1)	32(15.1)		n=11	9 (23.7)	2 (6.5)	
	<b>Stage III</b>	n=67	33(15.6)	34(16)		n=27	19 (50)	8 (25.8)	
	<b>Stage IV</b>	n=52	16(7.5)	36(17)		n=20	6 (15.8)	14 (45.2)	
<b>CEA (ng/ml)</b>	<b>&lt;4</b>	n=106	64(30.2)	42(19.8)	0.001	n=19	11 (28.9)	8 (25.8)	<b>&lt;0.001</b>
	<b>&gt;4</b>	n=106	39(18.4)	67(31.6)		n=50	27(71.1)	23(27.4)	

As for comparison between the present study and the one by Yu-Chen Shiu,<sup>9</sup> with regards to male preponderance of the disease, relatively low positive family history and histologically being moderately differentiated adenocarcinoma, our study was in approval of the data shown in the previous studies.

Most of the lesions, colonoscopically, appeared to be ulcerative, which again was in concordance with our study, however location and size of the primary tumour did not yield comparable results.

The present study, however, did show that CEA and CRP had a statistically significant relationship with respect to the

stage of the disease and recurrence rates during followup. This again was true as per previous studies from various centres including the Yu-Chen Shiu study.

CRP, as for the statistics, was not regarded as an independent prognostic factor in our study, however there was a positive relation with the burden of disease. We believe in the observation made by Neilson et al,<sup>14</sup> were they considered the increase in CRP to poorer survival of the patient. They also concluded with the proportionate increase in morbidity in patients with raised CRP values. But, as said, to condition this statement, a better study population would be ideal with a longer follow up.

When relating to the cancer specific survival, our patients were followed for a short period (about 3 to 6 months), which does not render us any conclusion. A similar study reported by Chung and Chang,<sup>15</sup> proposed the prediction of CRP levels with the outcome of colorectal cancer and decreased immunity. We agree on their observation regarding the outcome as our study is relating the CRP levels with advanced stage of the disease. Also we assume that inflammatory response increases as tumor increases in size and becomes bigger and more advanced.

50 out of the 69 patients in our study had elevated CEA preoperatively (72.4%). 33 out of 43 patients with intraoperative/histopathological evidence of metastases had elevated CEA preoperatively (76.7%). 31 of the 43 patients with intraoperative/histopathological evidence of metastases had hypoalbuminemia preoperatively (72.1%). 44 patients of the 69 in the present study had preoperative hypoalbuminemia (63.7%).

17 of the 20 patients in AJCC Stage IV had hypoalbuminemia preop (85%) with a strong association ( $p=0.027$ ). Postoperative period Stage IV disease patients persisted to have hypoalbuminemia, 19 of the 20 patients in this group persisted to have low albumin levels (95%).

This is concordance with the study as per Heys et al<sup>16</sup> published in *J.R.Coll Surg.Edinb*; 1998 which showed that serum albumin was an individual prognostic indicator in detecting advanced colorectal disease preoperatively, outcome and recurrence rates.

## V. CONCLUSIONS

69 patients were included in our study with the earliest followup at 3 weeks postoperatively and the latest at 6 months. Serial preoperative, postoperative and followup CEA, CRP and albumin levels were analyzed.

Following were the conclusions made in the present study -

### C- reactive protein (CRP)

- Polypoidal lesions seemed to have higher CRP levels as compared to patients with ulcerative lesions and infiltrative lesions.
- Higher CRP values were observed in patients with poorer differentiation of tumor.
- There was statistical significance between CRP and CEA values as prognostic indicators.
- 

### Carcinoembryonic antigen (CEA)

- Poor histology carcinoma patients tend to have higher preoperative CEA levels as compared to the others. (signet ring>> mucinous>> adenocarcinoma)
- Our current findings indicate that an abnormal pre and postoperative serum CEA level observed, significantly correlated with the depth of tumor invasion, the status of lymph node metastasis, advanced MAC stage, and higher postoperative relapse.

### Albumin

- Hypoalbuminemia was also strongly associated with poorer prognosis and poor histopathological variants.
- Persistent hypoalbuminemia is a feature of advanced disease and should be monitored serially and for longer period to arrive at a consensus.

To conclude, CEA, CRP and albumin were found to have statistical significance as preoperative and postoperative indicators of prognosis of colorectal carcinomas and should be followed up serially in all patients who have undergone surgery with curative intent.

## REFERENCES

- [1] Posner MC, Steele GD. Adeno carcinoma colon and rectum. In: Pemberton JH, editor. Shackelford's Surgery of Alimentary Tract, Vol 4. 5th ed. W.B.Saunders. p. 219-26.
- [2] Gold P, Freedman SO. Specific CEAS of the human digestive system. *J Exp. Med* 1972; 136:100-129.
- [3] Rosenthal KL, Palmer JL, Harris JA et al. Antibody-induced redistribution of CEA on the cell surface: utilization in separation of CEA and isoantigen A. *Journal of Immunology* 1975; 115(4):1049-1053.
- [4] Yeh. CRP as a mediator of disease. *Circulation* 2004; 109:11-14.
- [5] Significance of preoperative elevation of CRP as an indicator for prognosis in CRC. *Am J Surg* 1998; 176:335-8.
- [6] Ulcerative colitis and Crohn's disease as colorectal cancer risk. *GUT* 1994; 35:1590-2.
- [7] O'Brien MJ. Cancer of the colon and rectum: current concepts of aetiology and pathogenesis. *BriMed Sci* 1988; 157: 5-15.
- [8] Umpleby HC, Bristol B), Ranney JB, Williamson RCN. Survival of 727 patients with single carcinomas of the large bowel. *Dis Colon Rectum*1984; 27: 803-10.
- [9] Shiu YC, Lin JK, Huang CJ, Jiang JK, Wang LW, Huang HC, Yang SH et al. Is C reactive protein a prognostic factor of colorectal cancer?. *Diseases of the colon and rectum* 2001; Vol51:4,443-449.
- [10] Holyoke ED, Chu TM, Evans JT. CEA as a prognosticator and monitor in patients with colon cancer. In *Proceedings of the Third International Symposium on the Detection and Prevention of Cancer*. New York: April 1976.
- [11] Wanebo HJ, Rao B, Pinsky CM, et al. Preoperative CEA level as a prognostic indicator in colorectal carcinoma. *New England Journal of Medicine* 299(9): 448-451; 1978.
- [12] Goslin R, Steele G Jr, McIntire J et al. The use of preoperative plasma CEA levels for the stratification of patients after curative resection of colorectal carcinoma. *Annals of Surgery* 1980; 192(6):747-751.
- [13] Janusz J, Szymendra, Marek P, Nowacki, Andrzej W, Szawlowski. Predictive Value of Plasma CEA levels. *Disease of Colon and Rectum* 1982; 25(1):46-52.
- [14] Neilson et al. C- reactive protein levels, variation in the C- reactive protein gene, and cancer risk: the *Clin Oncol* 2006; 24:5216-22.
- [15] Chung Y-C, Chang Y-F. Serum interleukin- 6 levels reflect the disease status of colorectal cancer. *J Surg Oncol* 2003; 83:222-6.

- [16] Heys SD, Walker LG, Deehan DI, Ermin E et al. Serum albumin: a prognostic indicator in patients with colorectal cancer. J. R. Coll. Surg. Edinb. June 1998; 43:163-168.

#### AUTHORS

**First Author** – Dr. Rajesh Nair, MS Senior Resident, Dept of General Surgery, Kasturbe Medical Collge (KMC), Manipal University, Manipal, rajeshnair39@yahoo.com

**Second Author** – Dr. Bhavna Nayal MD, Assistant Professor, Kasturbe Medical Collge (KMC), Manipal University, Manipal, bhavnayal@yahoo.com

**Third Author** – Prof. B H Anand Rao (Professor) Department of Surgery, KMC, Manipal University, Manipal

# Three Phase Load Balancing and Harmonic Reduction using Distribution Static Compensator

Raghvendra Singh\*, Dharmendra Singh\*\*

\* Mtech Student, Dr C.V. Raman Institute Of Technology Kota

\*\* Faculty Electrical and Electronics Engg, Dr C.V. Raman Institute Of Technology Kota

**Abstract-** This paper presents a study of a D-STATCOM (Distribution Static Compensator) used for load balancing and harmonic reduction. The basic idea of the voltage sag mitigation, using a D-STATCOM is to dynamically inject a current of desired amplitude, frequency and phase into the grid line. The proposed method uses the instantaneous reactive power theory for generating reference values of current that need to be injected into the point of connection D-STATCOM in order to compensate the voltage errors. The proposed method offers structural simplicity and less calculation complexity. Simulation results indicate that this method is effective and D-STATCOM has good performance to balance the load and mitigate harmonic components of current.

**Index Terms-** load balancing, instantaneous reactive power theory, hysteresis controller, harmonic reduction.

## I. INTRODUCTION

All the electrical and electronic equipments are affected by the power quality disturbances. On uneven distribution of loads in the three phases there occurs the problem of load unbalancing and the increase in the use of power electronic equipments results in increase of harmonic content in the power distribution system. A variety of custom power devices are developed and successfully implemented to compensate various power quality problems in a distribution system. The various custom power devices are the DSTATCOM (distribution static compensator), DVR (dynamic voltage restorer) and UPQC (unified power quality conditioner). The current related power quality problems are mitigated by a shunt connected device called DSTATCOM. The effectiveness of DSTATCOM depends upon the control algorithm used to obtain the reference current. In this paper a instantaneous reactive power theory is used as a control algorithm to obtain the reference current. The hysteresis controller is then used to generate the gate signals for firing of the IGBT used in DSTATCOM.

## II. DESIGN OF DSTATCOM

A DSTATCOM is a device which is used in an AC distribution system where, harmonic current mitigation, reactive current compensation and load balancing are necessary. The building block of a DSTATCOM is a voltage source converter (VSC) consisting of self commutating semiconductor valves and a capacitor on the DC bus (Singh *et al*, 2008). The device is shunt connected to the power distribution network through a

coupling inductance. In general, the DSTATCOM can provide power factor correction, harmonics compensation and load balancing. The major advantages of DSTATCOM compared with a conventional static VAR compensator (SVC) include the ability to generate the rated current at virtually any network voltage, better dynamic response and the use of a relatively small capacitor on the DC bus. The size of the capacitor does not play an important role in steady-state reactive power generation, which results in a significant reduction of the overall compensator size and cost.

Fig. 1 shows the schematic diagram of a DSTATCOM connected to a three phase AC mains feeding three phase loads. Three phase loads may be a lagging power factor load or an unbalanced load or non-linear loads or mixed of these loads. For reducing ripple in compensating currents, interfacing inductors ( $L_f$ ) are used at AC side of the voltage source converter (VSC). A small series connected capacitor ( $C_f$ ) and resistor ( $R_f$ ) represent the ripple filter installed at PCC in parallel with the loads and the compensator to filter the high frequency switching noise of the voltage at PCC. The harmonics/reactive currents ( $I_{cabc}$ ) are injected by the DSTATCOM to cancel the harmonics/reactive power component of the load currents so that the source currents are harmonic free (reduction in harmonics) and load reactive power is also compensated.

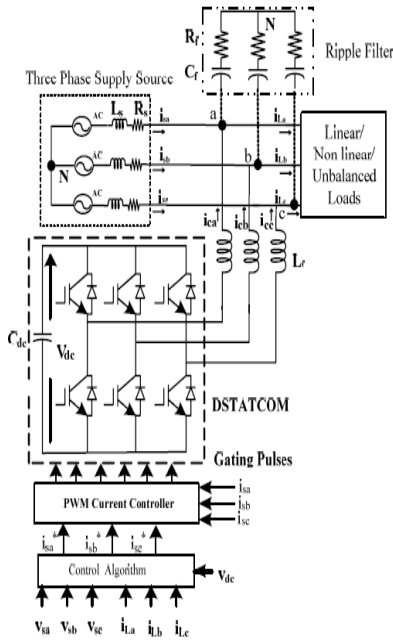


Figure 1. Schematic diagram of DSTATCOM

### III. CONTROL ALGORITHM OF DSTATCOM

Hirofumi Akagi and his coworkers have described an instantaneous method of generating reference currents for shunt compensator. Since then various interpretations of this method have been presented. This method is applicable to a three-phase, four-wire system. To begin with, we transform the three-phase voltages from  $a-b-c$  frame to  $a-\beta-0$  frame and vice versa using the following power invariant transformation

$$\begin{bmatrix} V_0 \\ V_\alpha \\ V_\beta \end{bmatrix} = \frac{1}{\sqrt{3}} \begin{bmatrix} \frac{1}{\sqrt{2}} & \frac{1}{\sqrt{2}} & \frac{1}{\sqrt{2}} \\ 1 & \frac{-1}{2} & \frac{-1}{2} \\ 0 & \frac{\sqrt{3}}{2} & \frac{-\sqrt{3}}{2} \end{bmatrix} \begin{bmatrix} V_a \\ V_b \\ V_c \end{bmatrix}$$

$$\begin{bmatrix} I_0 \\ I_\alpha \\ I_\beta \end{bmatrix} = \frac{1}{\sqrt{3}} \begin{bmatrix} \frac{1}{\sqrt{2}} & \frac{1}{\sqrt{2}} & \frac{1}{\sqrt{2}} \\ 1 & \frac{-1}{2} & \frac{-1}{2} \\ 0 & \frac{\sqrt{3}}{2} & \frac{-\sqrt{3}}{2} \end{bmatrix} \begin{bmatrix} I_a \\ I_b \\ I_c \end{bmatrix}$$

And

$$\begin{bmatrix} V_a \\ V_b \\ V_c \end{bmatrix} = \sqrt{\frac{2}{3}} \begin{bmatrix} \frac{1}{\sqrt{2}} & 1 & 0 \\ \frac{1}{\sqrt{2}} & \frac{-1}{2} & \frac{\sqrt{3}}{2} \\ \frac{1}{\sqrt{2}} & \frac{-1}{2} & \frac{-\sqrt{3}}{2} \end{bmatrix} \begin{bmatrix} V_0 \\ V_\alpha \\ V_\beta \end{bmatrix}$$

$$\begin{bmatrix} I_a \\ I_b \\ I_c \end{bmatrix} = \sqrt{\frac{2}{3}} \begin{bmatrix} \frac{1}{\sqrt{2}} & 1 & 0 \\ \frac{1}{\sqrt{2}} & \frac{-1}{2} & \frac{\sqrt{3}}{2} \\ \frac{1}{\sqrt{2}} & \frac{-1}{2} & \frac{-\sqrt{3}}{2} \end{bmatrix} \begin{bmatrix} I_0 \\ I_\alpha \\ I_\beta \end{bmatrix}$$

We can also use the same transform matrix for transforming currents. The instantaneous three-phase power is then given by  $P_{3\phi} = V_a I_a + V_b I_b + V_c I_c = V_\alpha I_\alpha + V_\beta I_\beta + V_0 I_0 = P + P_0$

where  $p$  is the total instantaneous real power in the three phase wires and  $P_0 = V_0 I_0$  is the instantaneous power in the zero-sequence network. Let us define the following variable

$$q = V_\alpha I_\beta - V_\beta I_\alpha = \frac{1}{3} \{ I_a (V_c - V_b) + I_b (V_a - V_c) + I_c (V_b - V_a) \}$$

the quantity  $q$  given in (7.9) is the reactive power absorbed by a circuit when both voltages and currents contain only the fundamental frequency. However, this quantity can be used in a much broader context when either voltages or currents or both have many frequency components. Akagi et al called this term the instantaneous imaginary power [7]. We can write from (7.8) and (7.9)

$$\begin{bmatrix} P \\ q \end{bmatrix} = \begin{bmatrix} V_\alpha & V_\beta \\ -V_\beta & V_\alpha \end{bmatrix} \begin{bmatrix} I_\alpha \\ I_\beta \end{bmatrix}$$

$$\begin{bmatrix} I_\alpha \\ I_\beta \end{bmatrix} = \frac{1}{V_\alpha^2 + V_\beta^2} \begin{bmatrix} V_\alpha & -V_\beta \\ V_\beta & V_\alpha \end{bmatrix} \begin{bmatrix} P \\ q \end{bmatrix}$$

To compensate the unbalanced load and harmonic component the compensating current in  $\alpha, \beta, 0$

$$\begin{bmatrix} I_{c\alpha} \\ I_{c\beta} \end{bmatrix} = \frac{1}{V_\alpha^2 + V_\beta^2} \begin{bmatrix} V_\alpha & -V_\beta \\ V_\beta & V_\alpha \end{bmatrix} \begin{bmatrix} P_{osc} \\ Q_t \end{bmatrix}$$



Where  $p_{osc}$  is the oscillating active power also termed as the harmonic content of active power and  $q$  is the reactive power taken from the source.

#### IV. PROBLEM STATEMENT AND SIMULATION DIAGRAM

The load unbalancing problem and its simulation is illustrated in the the following simulation diagram. The proposed control topology is being adopted and the system performance with a and without the controller is being analysed. The simulink model is shown in figure 2

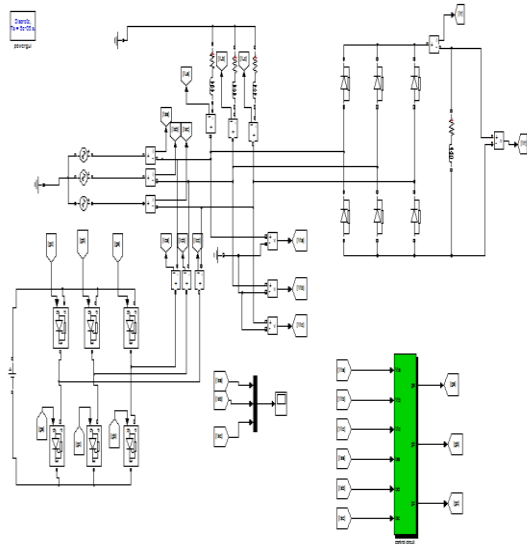


Figure 1 simulink model of the distribution power system

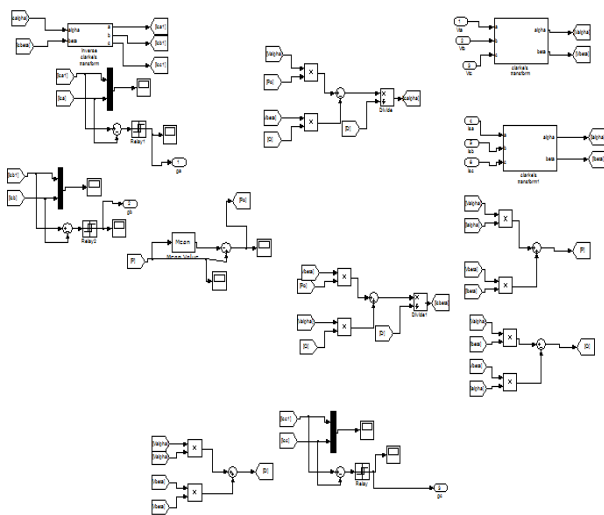


Figure 3 control circuit

#### V. RESULTS AND DISCUSSION

In the simulink diagram its is been shown that with a proposed control method the load unbalancing is been reduced considerably and also the THD that is total harmonic distortion has been reduced considerably. The two waveforms obtained

with a and without compensator has been shown in figure 4 and figure 5.

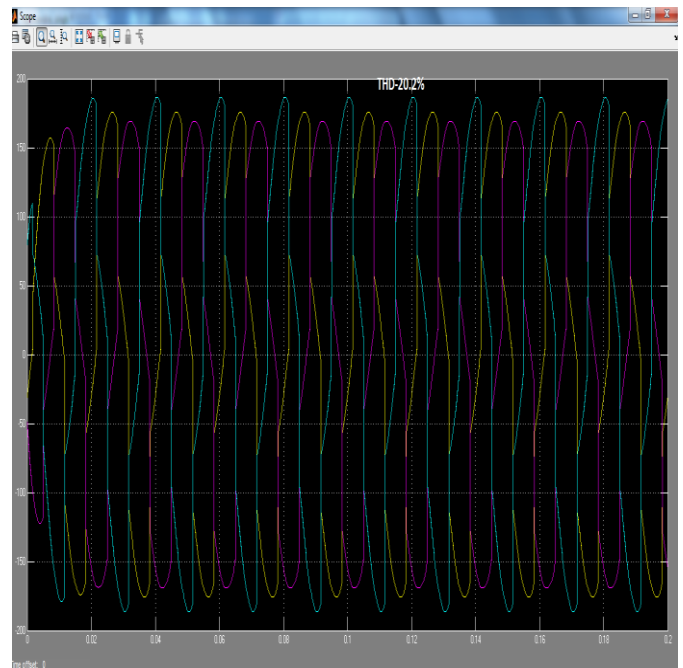


Figure 4: Three Phase Source Current Without Compensator

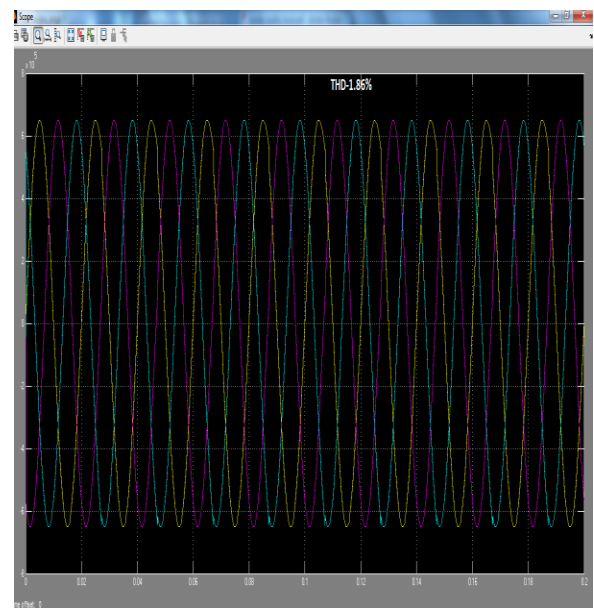


Figure 5: Three Phase Load Current With Compensator

#### VI. CONCLUSION AND FUTURE WORKS

From the results and waveforms shown in this paper as a results it can be concluded that on using the above controlling method a large amount of power quality problems can be eliminated and the on balancing the loads the voltage fluctuation problems associated with the phase having large load burden can be eliminated. In the future prospect research can be done on

modeling a STATCOM with the energy storing elements like inductors or capacitors.

- [19] A. Ferrero and G. Supeti-Furga, "A new approach to the definition of power components in three-phase systems under nonsinusoidal conditions," IEEE Trans. Instrumentation & Measurements, Vol. 40, No.3, pp. 568-577, 1991.

#### ACKNOWLEDGEMENT

I am thankful to all the faculty members of EE & EEE department to give their kind contribution of guiding me for publishing the paper specially Dharmendra Singh Sir.

#### AUTHORS

**First Author** – Raghvendra Singh, Mtech Student, Dr C.V. Raman Institute Of Technology Kota  
**Second Author** – Dharmendra Singh, Faculty Electrical and Electronics Engg, Dr C.V. Raman Institute Of Technology Kota

#### REFERENCES

- [1] N. G. Hingorani, "Introducing custom power," IEEE spectrum, vol.32, no. 6, pp. 41-48, June 1995.
- [2] L. Gyugyi, et al., "Principles and applications of Static, Thyristor-Controlled Shunt Compensators," IEEE Trans. PAS, vol. PAS-97, no.5, Sept./ Oct. 1978.
- [3] L. Gyugyi and E. R. Taylor, "Characteristics of Static Thyristor, Controlled Shunt Compensators for Power Transmission System Applications," IEEE Trans. PAS, vol. PAS-99, no.5, pp. 1795- 1804, Sept/ Oct. 1980.
- [4] K. R. Padiyar, FACTS Controllers in Power Transmission and Distribution, New Age International , New Delhi, 2007.
- [5] N. G. Hingorani and L. Gyugi, Understanding FACTS, Concepts and Technology of Flexible AC Transmission Systems, Piscataway, NJ: IEEE Press (2000)
- [6] Y. L. Tan, "Analysis of line compensation by shunt connected FACTs controllers: a comparison between SVC and STATCOM," IEEE power Eng. Rev., 1999, vol. 19 (8), pp.57-58.
- [7] P. Gonzalez and A. Cerrada, "Control System for a PWM-based STATCOM," IEEE Trans. Power Delivery, vol. 15, pp. 1252-1257, Oct. 2000.
- [8] B. Singh, R. Saha, A. Chandra and K. Al-Haddad, "Static Synchronous Compensators (STATCOM) : A review," IET Power Electron., vol. 2, Iss.4, pp 297- 324, 2009.
- [9] G. F. Reed, M. Takeda, F. Ojima, A. P. Sidell, R. E. Chervus and C. K. Nebecker, "Application of a 5MVA, 4.16kV D-STATCOM system for voltage flicker compensation at Seattle iron & metals," IEEE PES SM, 2000, pp. 1605-1611.
- [10] A. Ghosh and G. Ledwich, "Load Compensating DSTATCOM in Weak AC Systems," IEEE Trans. on Power Delivery, vol. 18, no.4, Oct. 2003.
- [11] S. Kincic and A. Chandra, "Distribution Level STATCOM (DSTATCOMs) for Load Voltage Support," IEEE Proc. Power Engg. Conf. on Large Engg. Systems, pp 30-37, 2003.
- [12] S. Bhattacharya, Po-Tai Cheng and D. M. Divan, "Hybrid Solution for Improving Passive filter performance in High Power Applications," IEEE Trans. on Indus. App. vol. 33, no.3, May/ June 1997.
- [13] H. Akagi, Y. Kanazawa, K. Fujita and A. Nabae, "Generalized theory of the instantaneous reactive power and its application," Electrical Engineering in Japan, Vol. 103, No.4, pp. 58-65, 198
- [14] H. Akagi, Y. Kanazawa and A. Nabae. "Instantaneous reactive power compensators comprising switching devices without energy storage components," IEEE Trans. Industry Applications, Vol. IA-20, No.3, pp. 625-630, 1984.
- [15] H. Akagi, A. Nabae and S. Atoh, "Control strategy of active power filters using multiple voltage-source PWM converters," IEEE Trans. Industry Applications, Vol. IA-22, No.3, pp. 460-465, 1986.
- [16] T. Furuhashi, S. Okuma, Y. Uchikawa, "A study on the Theory of Instantaneous Reactive Power," IEEE Trans. Industrial Electronics, Vol. 37, No. 1, pp. 86-90, Feb. 1990.
- [17] J. L. Willems, "A new interpretation of the Akagi-Nabae power components for nonsinusoidal three phase situations," IEEE Trans. on Instrumentation & Measurements, Vol. 41, No.4, pp. 523-527, 1992.
- [18] E. H. Watanabe, R. M. Stephan and M. Aredes. "New concepts of instantaneous active and reactive powers in electrical systems with generic loads," IEEE Trans. Power Delivery, Vol. 8, No.2, pp. 697-703,1993.

# Evaluation of Post Chemotherapy Bone Marrow Changes in Acute Leukaemia

Sushma Belurkar, Pankaj Bahadur Nepali, Bhawani Manandhar, Chetan Manohar

Department of Pathology, Kasturba Medical College, Manipal University, India

**Abstract- Introduction:** The incidence of Acute leukaemia both AML and ALL has been increasing over the years. Chemotherapeutic agents used in the treatment of acute leukemia cause damage to the hematopoietic environment of the bone marrow initially, followed by stages of hematopoietic recovery. The study of post chemotherapy bone marrow in acute leukemia is essential to analyse the response to chemotherapy and also to study the effects of chemotherapeutic drugs on the bone marrow micro environment.

**Aims:** 1) To study the changes in the marrow due to chemotherapeutic agents in acute leukemia patients.  
2) To study the response of leukemia to these drugs.  
3) To study and compare bone marrow findings in the post induction phase and maintenance phase.

**Materials and methods:** Total 65 cases of acute leukemia (50 cases of ALL and 15 cases of AML) in the post induction phase were enrolled for the study, out of these 44 cases (31 from ALL and 13 from AML) were followed up in the maintenance phase. Bone marrow aspirate and biopsy slides were studied for these cases.

**Results:** In the post induction phase bone marrow aspirates were predominantly hypocellular (43%) with normal to increased erythroid regeneration (64.6%) but decreased myelopoiesis and megakaryopoiesis. The erythroid maturation was mainly in the form of normoblastic or normoblastic with megaloblastoid changes (83.5%). Dyspoiesis was present in all three lineages (Erythroid series -40%, Myeloid series - 26%, Megakaryocytes-26.1%). In the maintenance phase bone marrow was normocellular or hypercellular (68.18%) with normal to increased erythropoiesis (72.7%) and predominantly normoblastic maturation (81%). Regeneration of myeloid series (63.6%) and megakaryocytes (90%) was also improved than in post induction phase. In the maintenance phase erythroid and myeloid dyspoiesis were decreased whereas megakaryocytic dyspoiesis was increased than in post induction phase.

**Conclusion:** Hence the study shows that though the bone marrow is hypocellular in the post induction phase, the cellularity improves during the maintenance phase. In the post induction phase erythroid regeneration appear first followed by myeloid and megakaryocytic regeneration.

**Index Terms-** Post chemotherapy, Bone marrow, Acute leukaemia

## I. INTRODUCTION

Acute leukemias (ALs) are heterogenous group of neoplasms due to uncontrolled proliferation of clonal neoplastic

hematopoietic stem cells, leading to neutropenia, anaemia, and thrombocytopenia<sup>1,2,3,4</sup>. Acute leukemia is of two types : Acute Myeloid Leukemia (AML) and Acute Lymphoblastic Leukemia (ALL).

Acute leukemia can be diagnosed on the basis of peripheral blood smear examination alone but bone marrow aspiration and bone marrow biopsy further support the diagnosis. Peripheral blood smear and bone marrow aspirate help to study percentage of blasts and morphologic evaluation of the blasts and other cells. In addition to this, bone marrow biopsy helps to evaluate the spatial organization of hematopoietic cells and specific histological features associated with the process (e.g., fibrosis, necrosis)<sup>5,6,7</sup>. Also after chemotherapy bone marrow examination helps to study the hematopoietic regeneration in detail<sup>2,8</sup>.

For the treatment of AML, in the induction phase Cytarabine, Daunorubicin or Idarubicin with or without Etoposide are used. For the treatment of ALL Vincristine, Asparaginase, Prednisolone, Daunorubicin with or without Intrathecal Methotrexate are used. All of these chemotherapeutic agents suppress normal haematopoiesis for variable period of time.

Haematopoietic regeneration after chemotherapy is usually monitored by repeated peripheral blood smear examinations. Bone marrow examination after chemotherapy help to study the pattern of haematopoietic regeneration in more detail, abnormalities in the bone marrow cytology, localization of regenerating haematopoietic cells, the attainment of complete remission, any evidence of relapse or resistant disease and also the side effects of chemotherapeutic agents<sup>5,6,9</sup>.

There are many studies where evaluation of bone marrow aspirate and biopsy have been done for the changes in the hematopoietic environment during the post induction phase, but there are very few studies where study of bone marrow during the maintenance phase have been done. Hence in our study we have evaluated the changes in the bone marrow aspirate and biopsy in the post induction phase and in the maintenance phase for the cases of acute lymphoblastic leukemia (ALL) and acute myeloid leukemia (AML). We have compared the findings of bone marrow during these two phases

## II. MATERIALS AND METHODS

This is a retrospective and prospective cross sectional study done in the Department of Pathology, Kasturba Medical College, Manipal. We studied bone marrow aspirate and biopsy in patients with acute leukemia (both acute myeloid leukemia and acute lymphoblastic leukemia) who presented to our hospital from January 2006 to December 2010.

**Inclusion criteria :**

Cases of acute leukemia ( ALL or AML) for whom bone marrow aspirate alone or bone marrow aspirate and biopsy both were done for the diagnosis and in the post induction phase.

**Exclusion criteria :**

1) Cases of acute leukemia (ALL or AML) which were diagnosed only by the study of peripheral blood smear alone and study of bone marrow was not done for the diagnosis.

2) Cases for whom bone marrow study was not done in the post induction phase.

3) Cases of acute leukemia (ALL or AML) diagnosed in some other centre but who received chemotherapy in our hospital.

4) Cases of acute leukemia (ALL or AML) diagnosed in our centre but referred to other centres for treatment.

Our patients received the following chemotherapy regimen in the Induction phase :

**A) Patients with ALL were assigned to Protocol MCP-841 :**

**Induction therapy :**

Daunorubicin (DNR) IV on days 8, 15, and 29;

Vincristine (VCR) IV on days 1, 8, 15, 22, and 29;

L-Asparaginase (ASP) intramuscularly (IM) every other day on days 2-20;

Oral prednisone (PRED) on days 1-28;

Methotrexate (MTX) intrathecally (IT) on days 1,8,15,and

22.

**B) Patients with AML were assigned to Cytarabine + Idarubicin (7+3 regimen)**

**Induction therapy :**

Cytarabine (Ara-C) 100 mg/m<sup>2</sup>/d iv day 1 -7  
Idarubicin 12 mg/m<sup>2</sup>/d iv day 1- 3

We enrolled 65 cases of acute leukemia (50-ALL, 15AML) for the study. Bone marrow aspiration was done for all the cases, bone marrow biopsy was done for 38 cases (32 from ALL and 6 from AML). Bone marrow study was done in the fourth week of induction chemotherapy for ALL cases and in the second week of induction chemotherapy for AML cases.

We studied repeat bone marrow aspiration during maintenance phase for 45 cases (31 from ALL and 13) from AML. Both ALL and AML were found to be more common in males (64% in ALL and 66.7% in AML) which may be just a coincidence. The ALL cases were between the age of 1-39 years (mean 20years) and the AML cases were between the ages of 10-57 years ( mean 33.5 years).

All the bone marrow aspirate slides were stained with Leishmain stain after necessary procedures. All the bone marrow biopsy slides were processed and stained with Haematoxyllin and Eosin.

**III. RESULTS**

**NUMBER OF CASES ENROLLED IN THE STUDY**

<b>PHASE</b>	<b>STUDY</b>	<b>ALL</b>	<b>AML</b>
POST INDUCTION (65 cases)	BONE MARROW ASPIRATE	50	15
	BONE MARROW BIOPSY	32 OUT OF 50 cases	6 OUT OF 15 cases
MAINTENANCE (44 cases)	BONE MARROW ASPIRATE	31	13
	BONE MARROW BIOPSY	11 OUT OF 31 cases	2 OUT OF 13 cases

**BONE MARROW CELLULARITY IN POST INDUCTION PHASE AND MAINTENANCE PHASE**

<b>PHASE</b>	<b>TYPE OF LEUKEMIA</b>	<b>CELLULARITY</b>			
		<b>NORMAL</b>	<b>HYPOCELLULAR</b>	<b>HYPERCELLULAR</b>	<b>DRY TAP</b>
POST INDUCTION	ALL (50 cases)	15(30%)	23(46%)	5(10%)	7(14%)
	AML (15 cases)	2 (13.3%)	5(33.3%)	3 (20%)	5(33.3%)
	<b>TOTAL (65 cases)</b>	<b>17(26%)</b>	<b>28(43%)</b>	<b>8(12.3%)</b>	<b>12(18.46%)</b>
MAINTENANCE	ALL (31 cases)	18(58.1%)	9(29%)	3(9.7%)	1(3.2%)
	AML (13 cases)	3(23.1%)	2(15.4%)	6(46.2%)	2(15.4%)
	<b>TOTAL (44 cases)</b>	<b>21(47.7%)</b>	<b>11(25%)</b>	<b>9(20.4%)</b>	<b>3(6.8%)</b>

**INDIVIDUAL CELL LINEAGE IN POST INDUCTION PHASE AND MAINTENANCE PHASE**

<b>PHASE</b>	<b>TYPE OF LEUKEMIA</b>	<b>SERIES</b>	<b>CELL COUNT</b>			<b>DYSPOIESIS PRESENT</b>
			<b>NORMAL</b>	<b>DECREASED</b>	<b>INCREASED</b>	
POST INDUCTION	ALL (50 cases)	ERYTHROID	18 (36%)	12 (24%)	19 (38%)	23 (46%)
		MYELOID	25(50%)	25 (50%)	0	14 (28%)

	<b>AML (15 cases)</b>	MEGAKARYOCYTES	24 (48%)	23 (46%)	3 (6%)	14 (28%)	
		ERYTHROID	3 (20%)	7 (46.7%)	2 (13.3%)	3 (20%)	
		MYELOID	1 (6.7%)	9 (60%)	3 (20%)	3 (20%)	
	<b>TOTAL</b>	MEGAKARYOCYTES	3 (20%)	10 (66.7%)	0	3 (20%)	
		ERYTHROID	21(32.3%)	19(29.2%)	21(32.3%)	26(40%)	
		MYELOID	26(40%)	34(52.3%)	3(4.6%)	17(26.1%)	
	<b>MAINTENANCE</b>	<b>ALL (31cases)</b>	MEGAKARYOCYTES	27(41.5%)	33(50.7%)	3(4.6%)	17(26.15%)
			ERYTHROID	15(48.4%)	6 (19.4%)	10(32.3%)	5(16.1%)
			MYELOID	15(48.4%)	12(38.7%)	4(12.9%)	3(9.7%)
<b>AML (13 cases)</b>		MEGAKARYOCYTES	25(80.6%)	1(3.2%)	5(16.1%)	10(32.3%)	
		ERYTHROID	4(30.8%)	5(38.5%)	3(23.1%)	4(30.8%)	
		MYELOID	5(38.5%)	4(30.8%)	4(30.8%)	6(46.2%)	
<b>TOTAL</b>		MEGAKARYOCYTES	8(61.5%)	2(15.4%)	2(15.4%)	5(38.5%)	
		ERYTHROID	19(43.18%)	11(25%)	13(29.5%)	9(20.4%)	
		MYELOID	20(45.45%)	16(36.36%)	8(18.18%)	9(20.4%)	
		MEGAKARYOCYTES	33(75%)	3(6.8%)	7(15.9%)	15(34%)	

**Dyspoiesis in all three lineages**

Erythroid dyspoiesis was noticed in the form of nuclear budding, binucleate forms, multinucleate forms, increased mitoses and karyorrhesis

Myeloid dyspoiesis was seen in the form of abnormal nuclear lobation and giant bands (22%). In post induction phase increased myeloid precursors were seen in 26 cases (52%) of

ALL and 6 cases (40%) of AML. Whereas in the maintenance phase increased myeloid precursors were seen in 13 cases (41.9%) of ALL and 6 cases (46.2%).

Megakaryocytic dyspoiesis in our patients was present in the form of hypolobated forms, immature forms, and micromegakaryocytes.

**TYPE OF MATURATION OF ERYTHROID SERIES IN POST INDUCTION PHASE AND MAINTENANCE PHASE**

TYPE OF MATURATION OF ERYTHROID SERIES	POST INDUCTION PHASE			MAINTENANCE PHASE		
	ALL	AML	TOTAL	ALL	AML	TOTAL
<b>PREDOMINANT NORMOBLASTIC MATURATION</b>	42 (84%)	6 (40%)	<b>48(73.8%)</b>	26(83.9%)	10(76.9%)	<b>36(81.8%)</b>
<b>PREDOMINANT MEGALOBlastic MATURATION</b>	3 (6%)	0	<b>3(4.5%)</b>	1(3.2%)	0	<b>1(2.7%)</b>
<b>NORMOBLASTIC MATURATION WITH MEGALOBlastoid CHANGES</b>	20 (40%)	1 (6.7%)	<b>21(32.3%)</b>	10(32.3%)	4(30.8%)	<b>14(31.8%)</b>
<b>MICRONORMOBLAST PRESENT</b>	9 (18%)	0	<b>9(13.8%)</b>	9(19.4%)	3(23.07%)	<b>12(27.27%)</b>
<b>TYPE OF MATURATION COULD NOT BE ASSESSED</b>	5 (10%)	9 (60%)	<b>14(21.5)</b>	4(12.9%)	3(23.07%)	<b>7(15.9%)</b>

**OTHER FINDINGS IN POST INDUCTION PHASE AND MAINTENANCE PHASE**

OTHER FINDINGS IN BONE MARROW ASPIRATE	POST INDUCTION PHASE			MAINTENANCE PHASE		
	ALL	AML	TOTAL	ALL	AML	TOTAL
<b>MULTIVACUOLATED FAT CELLS</b>	6 (12%)	3(20%)	<b>9(13.8%)</b>	1(3.2%)	2(15.4%)	<b>3(6.8%)</b>
<b>INCREASED MITOSES</b>	7 (14%)	1(6.7%)	<b>8(12.3%)</b>	3(9.7%)	0	<b>3(6.8%)</b>
<b>INCREASE MACROPHAGES WITH INGESTED DEBRIS</b>	7 (14%)	3(20%)	<b>10(15.3%)</b>	10(32.3%)	5(38.5%)	<b>15(34.09%)</b>
<b>HEMOSIDERIN LADEN MACROPHAGES</b>	13 (26%)	7(46.7%)	<b>20(30.7%)</b>	5(16.1%)	3(23.1%)	<b>8(18.8%)</b>
<b>HAEMOPHAGOCYTOSIS</b>	4 (8%)	2(13.3%)		0		



			<b>6(9.2%)</b>		0	<b>0(0%)</b>
<b>SEA BLUE HISTIOCYTES</b>	1 (2%)	1(6.7%)	<b>2(3.07%)</b>	0	1(7.7%)	<b>1(2.2%)</b>

**BONE MARROW BIOPSY FINDINGS IN POST INDUCTION PHASE OF ALL AND AML**

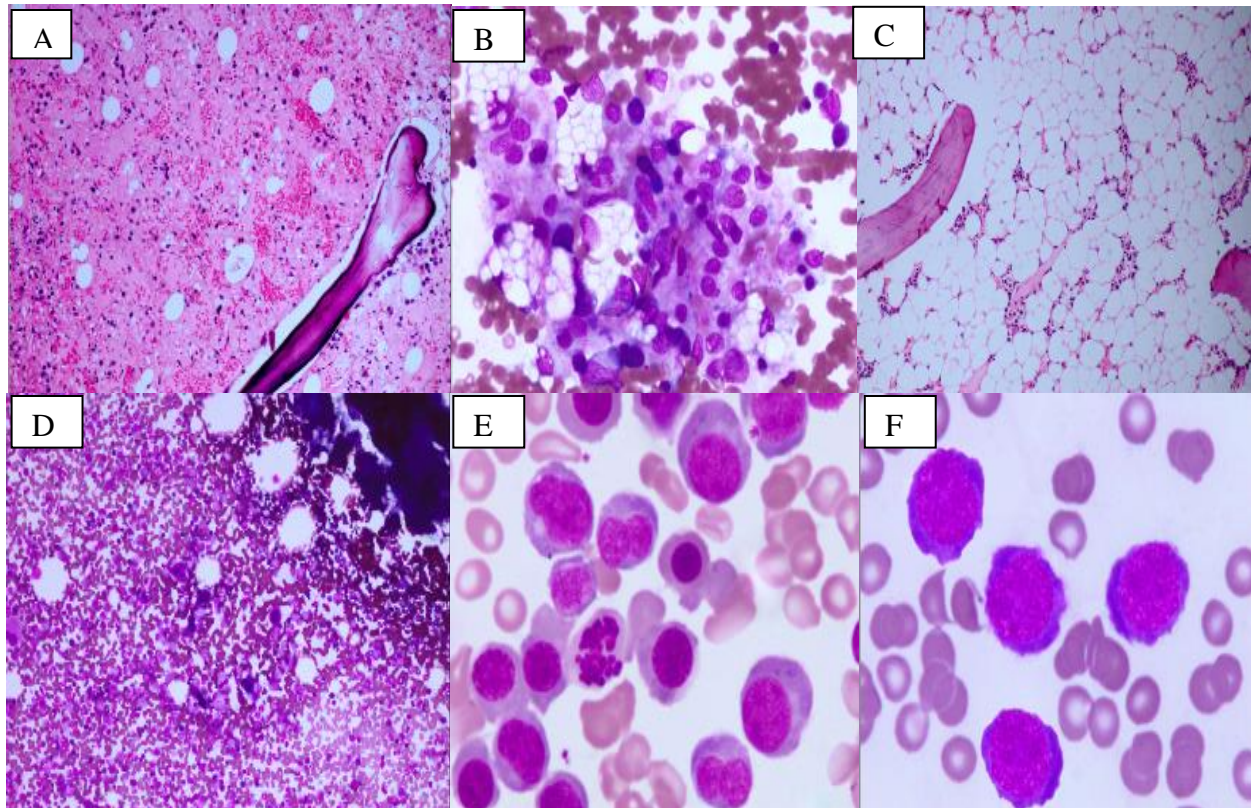
<b>BIOPSY FINDINGS POST INDUCTION PHASE OF ACUTE LEUKEMIA 38 CASES</b>	<b>NUMBER AND PERCENTAGE</b>
STROMAL EDEMA	6(15.8%)
PARATRABECULAR CLUSTERING	7(18.4%)
ALIP (abnormal localisation of immature precursors)	4(10.5%)
MEGAKARYOCYTE CLUSTERING	3(7.9%)
BONE MARROW FIBROSIS	1(2.6%)

In the maintenance phase out of 45 follow up cases bone marrow biopsy was done only in 13 cases (ALL:11, AML:2) and there was no significant finding except paratrabecular clustering of megakaryocytes which was seen in 1 case (7.7%)..

**IV. RELAPSE CASES**

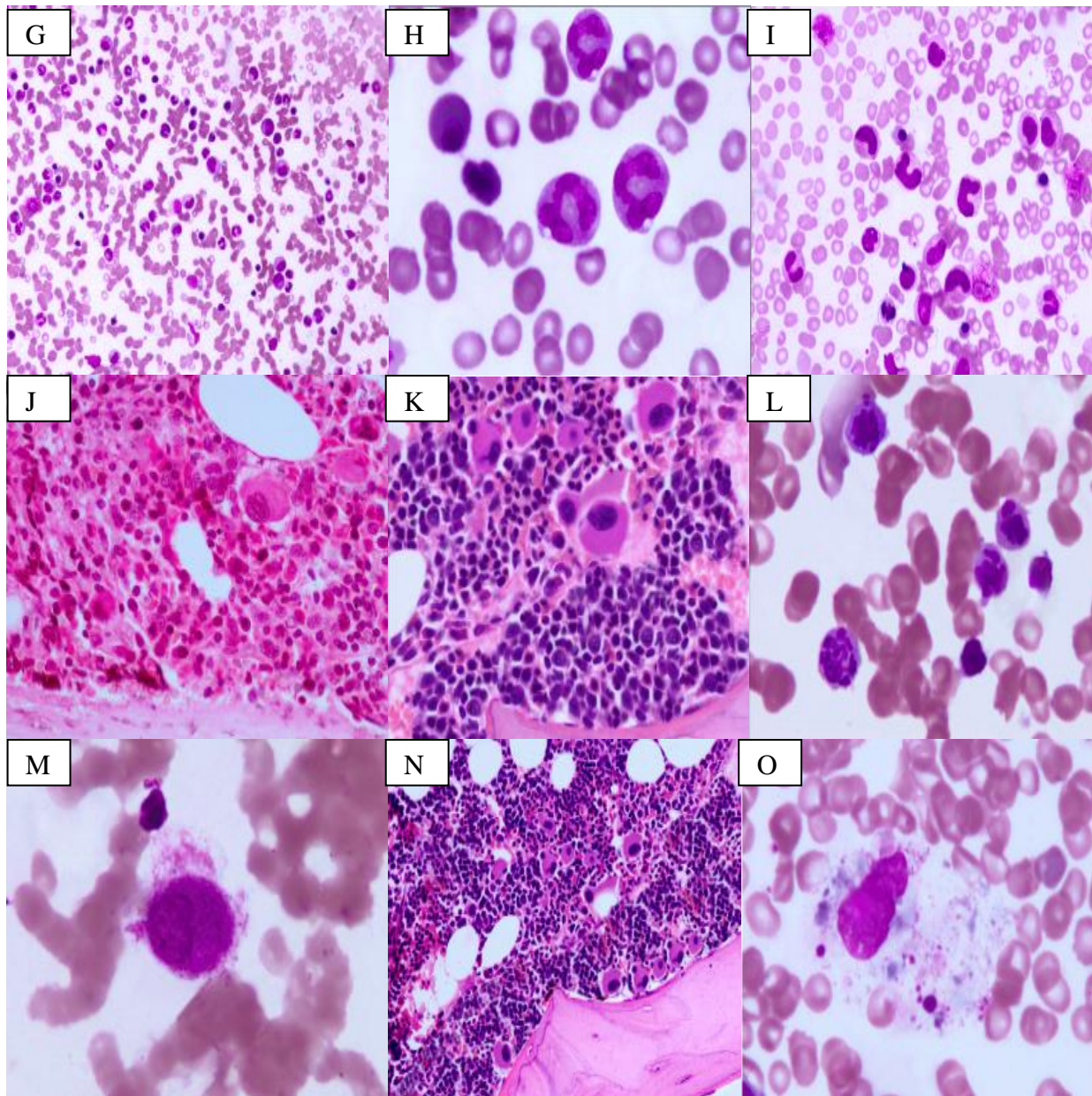
In our study out of 50 cases 14 cases had relapsed during follow up, out of which 9 were ALL and 5 were AML. In ALL, relapse occurred between 82-834days (mean of 257 days) from the day of starting chemotherapy and in AML, relapse occurred between 51-242 days (mean of 154 days) from the day of treatment.

Bone marrow in Post induction phase



A.Marked ablation of haematopoietic elements replaced by proliferating sinusoids and fibroblast(10X). B.Multivacuolated fat cell(40X) C.Markedly hypocellular marrow(10X) D.Hypercellular marrow particle with features of regeneration(10X) E.Erythroid hyperplasia with megaloblastoid maturation and dyspoiesis(40X) F.Megaloblastoid changes(100X)





G.Myeloid hyperplasia(20X) H.Myeloid dyspoiesis in the form of abnormal lobation(100X) I.Giant bands(40X) J.Trephine biopsy showing abnormal localaization of immature precursors(ALIP)(20X) K.Megakaryocytic dyspoiesis in the hypolobated form(20X) L.Atypical mitoses(100X) M.Micromegakayocyte(40X) N.Paratrabecular clustering of megakaryocytes(20X) O.Macrophage with ingested debris(100X)

## V. DISCUSSION

Hematopoietic regeneration after chemotherapy for acute leukemia is usually monitored by repeated peripheral blood smear and bone marrow aspirate analysis. Bone marrow biopsy helps further by evaluation of spatial organization of the hematopoietic cells<sup>5,6,7</sup>.

The main mechanism of action of most of the chemotherapeutic agents used for treatment of acute leukemia is by inhibiting DNA repair, inhibiting DNA and RNA synthesis and by causing fragmentation of DNA leading to cell cycle

arrest, cell apoptosis and cell death. Hence the consequences of these chemotherapeutic agents are injurious to the hematopoietic microenvironment leading to bone marrow suppression, mitotic arrest in the blasts, megaloblastoid changes in erythroid precursors<sup>10,11</sup>. In our study we evaluated the changes in the hematopoietic environment after induction chemotherapy and in the maintenance phase of chemotherapy.

Post induction bone marrow aspirates done at the end of 4<sup>th</sup> week in ALL cases, and at the end of 2<sup>nd</sup> week in AML cases were predominantly hypocellular (43% of cases), remaining 38% were normocellular to hypercellular where as in some cases bone marrow aspirate was dry tap. Our bone marrow findings were

similar to the findings in the studies done by Bruce D. Cheson et al<sup>2</sup>, A study done by Islam et al<sup>9</sup> showed that bone marrow aspirate of AML cases in post induction patients were predominantly hypocellular. These findings are unlike the study done by Elizabeth L. Gerard<sup>6</sup> where the post induction bone marrow were predominantly normocellular. N. Hurwitz<sup>5</sup> in his study has stated that by fourth week of induction chemotherapy bone marrow aspirate should have normal age related cellularity. In other literatures hypocellularity is mainly reported in post induction phase of AML and not in ALL. But in our study hypocellularity was a feature of both AML and ALL in post induction phase. Though the bone marrow was predominantly hypocellular in post induction phase, the cellularity recovered to predominantly normocellular to hypercellular in the maintenance phase. Hence the hypocellularity observed during the post induction phase may be due to the antileukemic effect of the chemotherapeutic agents or could be due to their side effects as most of these drugs damage the hematopoietic environment.

Post induction bone marrow aspirate of our cases had predominantly normal to increased (64.6%) erythropoiesis, whereas myelopoiesis (52.3%) and megakaryopoiesis (50.7%) were predominantly suppressed. Hence we concluded that in the post induction period regeneration of erythroid series precedes the regeneration of myeloid series and megakaryocytes. According to the article by N. Hurwitz, the first sign of bone marrow regeneration is the appearance of unilinear islands of erythroid precursors followed by myeloid cells and megakaryocytes<sup>5</sup>.

The type of erythroid maturation we observed in the post induction phases of our cases was predominantly normoblastic or normoblastic maturation with megaloblastoid change and few cases with predominantly megaloblastic maturation. Erythroid dyspoiesis was present in 40% of our cases, commonly in the form of nuclear budding, binucleate forms, multinucleate forms and karyorrhexis. Study done by B S Wilkins and N Hurwitz also showed erythroid cells with megaloblastic maturation<sup>5,7</sup>. These megaloblastoid changes could be the effect of chemotherapeutic drugs like Methotrexate, Danorubicin / Idarubicin, Cytarabine due to inhibition of DNA synthesis. We noticed increase in the stage of basophilic normoblasts in 10.7% of our cases. In a study done by B S Wilkins et al, erythroid cells arrested in the stage of basophilic normoblasts was seen in 45% of the cases in the post induction phase. N. Hurwitz et al, in his study had mentioned about the partial arrest of maturation of erythroid series in the basophilic normoblastic stage during the post induction phase<sup>5</sup>. All we can conclude from these findings is that the heterogeneity in the stages of erythroid maturation seen in a normal marrow will be lost after chemotherapy and there will be maturation arrest in the erythroid series.

In normal marrow erythropoietic foci are not found in the paratrabecular region. Bone marrow biopsy done among 38 of our cases in the post induction phase showed abnormal paratrabecular clustering of erythroid cells in 18.4%. B S Wilkins et al in their study has mentioned about abnormal paratrabecular clustering of erythroid cells in 60% of their cases and showed marked suppression of granulopoiesis at that time. But biopsies done later on in their cases showed returning of erythroid cells to their normal place with recovery of granulopoiesis<sup>7</sup>.

Hence we assume that after chemotherapy the maturing erythroid cells may lose their normal heterogeneity and may have abnormal paratrabecular clustering. Both of these findings will recover later on.

When we evaluated the bone marrow in 44 cases during the maintenance phase, erythroid regeneration was normal to increased in 72.68%. The regenerating erythroid cells were predominantly in the normoblastic stage in 81% of the cases, whereas normoblastic maturation with megaloblastoid changes had decreased from 32.3% in the post induction phase to 22.7%. The erythroid dyspoiesis also reduced from 40% in the post induction phase to 20% in the maintenance phase. Also the findings seen in the post induction phase like erythroid precursors in the stage of basophilic normoblast and abnormal paratrabecular clustering of erythrocytes got resolved as the patients entered into maintenance phase.

These findings indicate that not only the number of erythroid series but also the type of erythroid maturation reverts back to normal (predominantly normoblastic maturation) once the patient progresses from post induction phase to maintenance phase. Also there will be reduction in dyspoiesis and megaloblastoid changes with regain of normal heterogeneity and normal topography.

In the post induction phase granulopoiesis was seen to regenerate only after erythropoiesis. In almost 52.3% of the cases myelopoiesis was decreased. There was paucity of mature granulocytes and increase in myeloid precursors (49.23% of the cases). Dyspoietic myeloid cells with abnormal lobations and giant bands were seen in 26.1% of the cases. Abnormal localization of immature precursors (ALIP) was seen in 10.4% out of 38 biopsies in the post induction phase. B S Wilkins in his study has mentioned about the reduction in the number of granulopoiesis, paucity of mature granulocytes, increase in precursors forms but not the myeloid dyspoiesis and abnormal localization in the post induction phase<sup>7</sup>. But most of these changes were seen to revert back to normal in the maintenance phase. Myelopoiesis regeneration in the maintenance phase was seen in (63.6%) cases with increase in mature forms, decrease in dyspoiesis (20.45%) and normalization of ALIP.

In the post induction phase of our cases megakaryopoiesis was decreased in 50.7% of the cases and megakaryopoietic regeneration was seen to occur last. Megakaryocytic dyspoiesis seen in 26.15% of the cases were in the form of hypolobated forms, immature forms, micromegakaryocytes, mononuclear variants and megakaryocytes with bizarre angulated nuclei. Abnormal clustering of the megakaryocytes was seen in 7.9% of the bone marrow biopsies. All of these findings were also seen in the study done by B S Wilkins<sup>7</sup>. Though megakaryopoietic regeneration occurred last during the post induction phase, in the maintenance phase megakaryocytic regeneration (90%) was better than regeneration of the erythroid series and myeloid series. Despite of having good regeneration, megakaryocytic dyspoiesis persisted for long duration even in the maintenance phase in the form of hypolobated forms, immature forms and micromegakaryocytes. This is well supported by the study done by B S Wilkins in which megakaryocytic dyspoiesis persisted for a long duration (for weeks to months) during follow up<sup>7</sup>. Hence our study showed that in the post induction phase, megakaryocytic regeneration occurred last, with dyspoiesis and



abnormal clustering, which will recover as the patient progresses to the maintenance phase however dyspoiesis may take long time for recovery.

We also noticed some other findings in the bone marrow like stromal oedema (15.8%), multivacuolated fat cells (13.8%), increased mitoses, macrophages with ingested debris (15.3%), hemosiderin laden macrophages (30.7%), hemophagocytosis(9.2%) and sea blue histiocytes (3.07%). These findings were also present in the studies done by N. Hurwitz<sup>5</sup> and Islam et al<sup>9</sup>. According to their literature the earliest bone marrow changes after chemotherapy were stromal oedema with granular eosinophilic exudates, marrow hypocellularity, multiloculated fat cells sinusoidal ectasis, macrophages with ingested debris, haemosiderin laden macrophages. All these findings either reduce or disappear in the later biopsies. They have also mentioned that precursor multilocular fat cells give rise to unilocular fat cells and the islands of regenerating hematopoietic cells are seen around the aggregates of fat cells hence fat cells play important role for restitution of hematopoiesis.

On retrospective analysis we found that those cases which had relapsed of had suppressed erythropoiesis during the maintenance phase as compared to those non relapsed cases which had good erythropoiesis in the post induction phase. Hence we can assume that erythroid regeneration may play a significant role in the course of the disease. Similarly hypocellularity in post induction phase, erythroid dyspoiesis and marked suppression of megakaryocyte in post induction phase may also play a significant role in the prognosis of the disease.

## VI. CONCLUSION

We conclude that chemotherapeutic drugs can cause various effects on the bone marrow microenvironment. It is essential to study these post chemotherapy changes for proper evaluation of the response to therapy and the to analyse the regeneration of bone marrow following chemotherapy. Bone marrow studies should be done both in post induction and in the maintenance phase for better evaluation of the response and the regeneration of the marrow. Though there is suppression of the marrow with evidence of marrow damage in the post induction phase, most of these changes revert back to normal in the maintenance phase. Marrows which show poor regeneration in the maintenance phase can indicate poor prognosis for the patient.

## REFERENCES

- [1] Tallman MS, Gilliland DG, Rowe JM. Drug therapy for acute myeloid leukemia. *Blood*.2005;106:1154-1163.
- [2] Cheson BD, Bennett JM, Kopecky KJ et al. Revised recommendations of the international working group for diagnosis, standardization of response criteria, treatment outcomes, and reporting standards for therapeutic trials in acute myeloid leukemia. *J Clin Oncol*. 2003;21:4642-4649.
- [3] Haase D, Feuring-Buske M, Konemann S, et al. Evidence for malignant transformation in acute myeloid leukemia at the level of early hematopoietic stem cells by cytogenetic analysis of CD34+ subpopulations. *Blood*.1995;86:2906-2912.
- [4] David R Head. Diagnosis and Classification of the Acute Leukemia and Myelodysplastic syndrome. In: John P Greer, John Foerster, George M Rodgers, Frixos Paraskevas, Bertil Glader, Daniel A Arber et al eds.

Wintrobe's Clinical Hematology.12th ed. Lippincott William and Wilkins.2008:1808-1819.

- [5] N. Hurwitz. Bone marrow trephine biopsy changes following chemotherapy and / or bone marrow transplantation. *Current diagnostic pathology*.1997;4:196-202.
- [6] Elizabeth L. Gerard, Judith A. Ferry, Philip C. Amrein, David C. Harmon, Robert C. McKinstry, Bernice E. Hoppel et al. Compositional changes in vertebral bone marrow during treatment for acute leukemia : assessment with quantitative chemical shift imaging. *Radiology*.1992;183 : 39-46.
- [7] B S Wilkins, A G Bostanci, M F Ryan, D B Jones. Haemopoietic regrowth after chemotherapy for acute leukemia : an immunohistochemical study of bone marrow trephine biopsy specimens : *J Clin Pathol*.1993;46: 915-921.
- [8] Hakura Itakura, Steven E Coutre. ALL in Adults. In: John P Greer, John Foerster, George M Rodgers, Frixos Paraskevas, Bertil Glader, Daniel A Arber et al eds. Wintrobe's Clinical Hematology 12th ed. Lippincott William and Wilkins.2008:1820-1842.
- [9] A Islam. Pattern of bone marrow regeneration following chemotherapy for acute myeloid leukemia. *Journal Of Medicine*.1987;18(2): 108-22.
- [10] Bruce A Chabner, Philips C Amrein, Brian Druker, M Dror Michaelson, Constantine S et al. Chemotherapy in Neoplastic diseases. In: Lawrence L Bruton, John S Lazo, Keith L Parker eds. Goodman and Gilman's The Pharmacological Basis of Therapeutics 11th ed. McGraw Hill:1315-1404.
- [11] Miscellaneous Disorders. In: Barbara J Bain, David M Clark, Irvin A Lampert, Bridget S Wilkins eds. Bone Marrow Pathology 3rd ed. Blackwell Science:391-429.

## AUTHORS

**First Author** – Sushma Belurkar, Department of Pathology, Kasturba Medical College, Manipal University, India  
**Second Author** – Pankaj Bahadur Nepali, Department of Pathology, Kasturba Medical College, Manipal University, India  
**Third Author** – Bhawani Manandhar, Department of Pathology, Kasturba Medical College, Manipal University, India  
**Fourth Author** – Chetan Manohar, Department of Pathology, Kasturba Medical College, Manipal University, India

# Review on Optical MIMO System

Mridu Jain\* Ritu Dubey\*\* Vishal Pasi\*\*\*

\* M-tech scholar Digital Comm. B.T.I.R.T. Sagar (M.P.)

\*\* Asst. Prof. E&C B.T.I.R.T. Sagar (M.P.)

\*\*\* Asst. Prof. E&C B.T.I.R.T. Sagar (M.P.)

**Abstract-** In this paper present review study on optical communication with OFDM system by MIMO technique. At reviewing background knowledge that includes fundamentals of modulation and communication, signal propagation and channel modeling. In this paper ideas behind formulas, rather than mathematical derivations, are emphasized and several examples are provided to allow easy comprehension of the concepts. in-depth treatment of two essential signal processing tasks synchronization and channel estimation—is discussed. Then, MIMO (multiple-input multiple output) techniques with their application to optical OFDM systems are also delineated. This part also aims to present the readers with modern signal-processing algorithms in optical OFDM baseband receivers talks about hardware design, from design methodology to design of essential blocks with a couple of examples that cover the latest OFDM receiver and its developments.

**Index Terms-** OFDM (orthogonal frequency division multiplexing), MIMO (multiple input multiple output) DSB (digital broadcasting Systems), DAB (digital audio broadcasting), QPSK (quadrature phase shift keying) and QAM (quadrature amplitude modulation).

## I. INTRODUCTION

This Pursuance for better ways of living has been instrumental in advancing human civilization. Communication services available at any time and place free people from the limitation of being attached to fixed devices. Nowadays, thanks to the remarkable progress in wireless technology, affordable wireless communication service has become a reality. Mobile phones hook people up whenever and wherever they want. Digital audio and video broadcasting offers consumers high-resolution, better-quality and even interactive programmes. The devices are now thin, light, small and inexpensive. Furthermore, smart mobile phones capable of multimedia and broadband internet access are showing up on the shelves [2,3].

Several projects studying wireless networks with different extents of coverage are under way. They will enable wireless access to internet backbone everywhere, either indoors or outdoors and in rural or metropolitan areas. In the following, their evolution and future developments will be introduced. The essential role that the orthogonal frequency-division multiplexing (OFDM) technique plays in wireless communication systems will also become very clear.

### *Digital Broadcasting Systems*

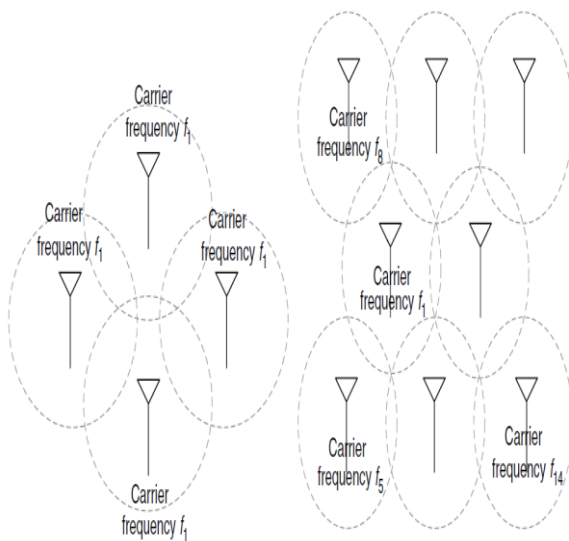
In the modern world, most people fill the need for information and entertainment through audio and video broadcasting. The inauguration of AM radio can be traced back to the early twentieth century, whilst analog TV programmes were first broadcast before the Second World War. Around the middle of twentieth century, FM radio programmes became available. These technologies, based on analog communication, brought news, music, drama, movies and much more into our daily lives. To provide more and better programmes, digital broadcasting techniques, such as digital audio broadcasting (DAB) and digital video broadcasting (DVB), began to replace the analog broadcasting technologies in the past several years [4,5].

### *Digital Audio Broadcasting (DAB)*

DAB is among the first standards that use the OFDM technique. The DAB project started in mid-1980 [1]. Based on OFDM, DAB has one distinct benefit: a single-frequency network (SFN). In a single frequency broadcasting network, one carrier frequency can be used for all transmitters to broadcast the same radio programme in the entire country without suffering from co-channel interference. On the other hand, in the FM system, only one out of approximately 15 possible frequencies can be used, resulting in a very inefficient frequency re-use factor of 15[6,7]. A single-frequency network and a multi-frequency network are illustrated in Fig.

In the DAB system, it is not necessary to search for radio stations as is necessary with AM/FM radios. The programmes of all radio stations are integrated in so-called multiplexes. Multiplexes save on the maintenance cost of individual radio stations. In addition, variable bandwidths can be assigned to each programme, fulfilling their respective demands for sound quality. Music radio multiplexes can transmit at a rate up to the highest-quality 192 Kbps, while mono talk and news programmes may use only 80 Kbps. Furthermore, the DAB system features better mobile reception quality thanks to the OFDM technique[11,12].





(a) Single-frequency network and (b) multi-frequency network

### Digital Audio Broadcasting (DAB)

DAB is among the first standards that use the OFDM technique. The DAB project started in mid-1980 [1]. Based on OFDM, DAB has one distinct benefit: a single-frequency network (SFN). In a single frequency broadcasting network, one carrier frequency can be used for all transmitters to broadcast the same radio programme in the entire country without suffering from co-channel interference. On the other hand, in the FM system, only one out of approximately 15 possible frequencies can be used, resulting in a very inefficient frequency re-use factor of 15. A single-frequency network and a multi-frequency network are illustrated in Fig.

In the DAB system, it is not necessary to search for radio stations as is necessary with AM/FM radios. The programmes of all radio stations are integrated in so-called multiplexes. Multiplexes save on the maintenance cost of individual radio stations. In addition, variable bandwidths can be assigned to each programme, fulfilling their respective demands for sound quality. Music radio multiplexes can transmit at a rate up to the highest-quality 192 Kbps, while mono talk and news programmes may use only 80 Kbps. Furthermore, the DAB system features better mobile reception quality thanks to the OFDM technique[8,9].

Digital Video Broadcasting (DVB) DVB is the European standard for digital television broadcasting [2]. The DVB standards include DVB-S for satellites, DVB-C for cables, DVB-T for terrestrial transmission and DVB-H for low-power handheld terminals. Among them, DVB-T and DVB-H utilize OFDM as the modulation scheme. DVB-T receivers started shipping in late-1990 and now digital DVB-T programmes are available in many countries. As the DAB system, DVB-T/H technology also supports countrywide single-frequency networks. In addition, DVB-T/H standards offer several modes of operation that are tailored for large-scale SFN and high mobility reception. On the other hand, researchers in wireless optical communications (WOC) are trying to find a way to gain the interest of communication companies by providing new and attractive alternatives to radio communications, as we must not lose sight of the fact that most wireless communications are

established inside rooms. Thus, WOC systems offer some advantages over their radio-frequency (RF) counterparts [15]: they are, theoretically, unregulated and have unlimited bandwidth. There is also an inherent security capability, as light (communication) is confined to the room, and there is immunity to multipath fading.

However, they are not exempt from drawbacks: strict power limitations due to eye-safety constraints, severe path losses and multipath dispersion and, last but not least, limited maximum achievable signal-to-noise ratio (SNR) due to unavoidable natural and artificial noise sources are the main problems. Over the last few years, OFDM has begun to be proposed for both fibre and wireless optical communications [4] as an effective solution to mitigating inter-symbol interference (ISI) caused by dispersive channels. Furthermore, the frequency-domain channel equalization provided by an OFDM system does not undergo severe complexity penalty when data rates and dispersion increase as opposed to serial time-domain equalizers, and MIMO techniques can be applied to these systems with relative ease. Finally, the complexity of transmitters and receivers is transferred from an analogue to a digital domain by employing Fast Fourier Transform (FFT) and Inverse FFT (IFFT) blocks as demodulators and modulators, respectively. Therefore, all these aspects favour the implementation of OFDM systems in the current digital era [13,14].

## II. OPTICAL COMMUNICATION

Today's telecommunication services intensely rely on optical-fiber systems. Such optical communication systems are requested to handle high speed, multi-channels, long-haul signal transmission [1]. Recently, optical coherent 100 Gb/s communication links became a critical technology for communication networks. Moreover, digital signal processing is under consideration as a promising technique for optical signal modulation, fiber transmission, signal detection and dispersion compensation. There are different reasons why the utilization of coherent detection associated digital signal processing can be very beneficial. Firstly, coherent detection is a promising technology to increase optical receiver sensitivity, permitting a greater span loss to be tolerated. Secondly, coherent detection enables supporting of more spectrally efficient modulation formats such as quadrature phase shift keying (QPSK) and quadrature amplitude modulation (QAM). And instead of implementing costly physical impairments compensation links, coherent detection allows digital signal processing for compensation of transmission impairments such as chromatic dispersion (CD), polarization mode dispersion (PMD), signal carrier offset, spectrum narrowing, etc. Furthermore, next generation optical transmission systems require adaptive for time varying transmission impairments such as channel spectrum narrowing and random phase noise. Digital signal processing is a powerful solution for future adaptive optical transmission links [10,11].

Fiber optics is a major building block in the telecommunication infrastructure. Its high bandwidth capabilities and low attenuation characteristics make it ideal for gigabit transmission and beyond. In this module, you will be introduced to the building blocks that make up a fiber optic communication

system. You will learn about the different types of fiber and their applications, light sources and detectors, couplers, splitters, wavelength-division multiplexers, and state-of-the-art devices used in the latest high-bandwidth communication systems. Attention will also be given to system performance criteria such as power and rise-time budgets. Companies such as AT&T, MCI, and U.S. Sprint use optical fiber cable to carry plain old telephone service (POTS) across their nationwide networks. Local telephone service providers use fiber to carry this same service between central office switches at more local levels, and sometimes as far as the neighborhood or individual home. Optical fiber is also used extensively for transmission of data signals. Large corporations, banks, universities, Wall Street firms, and others own private networks. These firms need secure, reliable systems to transfer computer and monetary information between buildings, to the desktop terminal or computer, and around the world. The security inherent in optical fiber systems is a major benefit. Cable television or community antenna television (CATV) companies also find fiber useful for video services. The high information-carrying capacity, or bandwidth, of fiber makes it the perfect choice for transmitting signals to subscribers [12].

The growth of the fiber optics industry over the past five years has been explosive. Analysts expect that this industry will continue to grow at a tremendous rate well into the next decade and beyond. Anyone with a vested interest in telecommunication would be all the wiser to learn more about the tremendous advantages of fiber optic communication. With this in mind, we hope this module will provide the student with a rudimentary understanding of fiber optic communication systems, technology, and applications in today's information world.

In wireless optical communications, the optical link is typically established by means of optical modulation (IM), in which the desired waveform is modulated onto the instantaneous power of the carrier, in conjunction with direct detection (DD) as a down-conversion technique at the receiver end. Therefore, the transmitted waveform  $x(t)$  is the instantaneous optical power of the emitter, and the received waveform  $y(t)$  is the instantaneous current in the receiving photo detector. In this way, the optical channel with IM/DD can be modelled as a baseband linear system with impulse response  $h(t)$  or, alternatively, this can be described in terms of the frequency response:

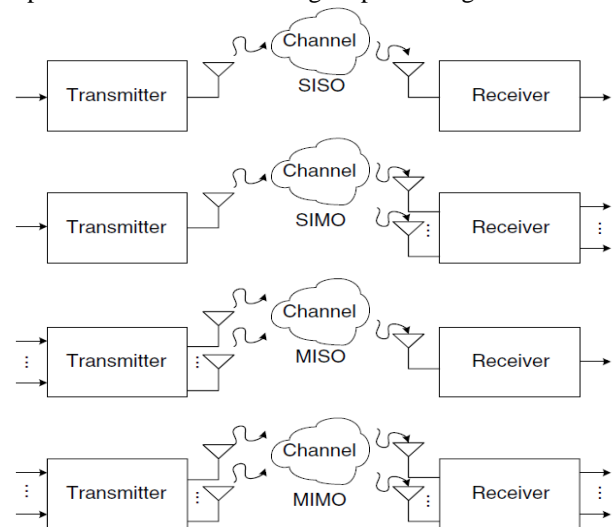
$$H(f) = \int_{-\infty}^{\infty} h(t)e^{-j2\pi ft} dt$$

which is the Fourier transform of  $h(t)$  [13,14]. This channel model  $h(t)$  is practically stationary because it only varies when emitter, receiver or objects in the room are moved by tens of centimetres. In many applications, optical links are operated in the presence of intense infrared and visible background light. The received background light adds shot noise, which is usually the limiting noise source in a well-designed receiver. Due to its high intensity, this shot noise can be modelled as white, Gaussian, and independent of  $x(t)$ . When little or no ambient light is present, the dominant noise source is receiver preamplifier noise, which is also signal-independent and Gaussian (though often nonwhite) [15]. Thus, the noise  $n(t)$  is usually modelled as Gaussian and signal-independent, and the instantaneous output current at the receiver can be represented as:

$$y(t) = Rx(t) \otimes h(t) + n(t)$$

### III. MIMO TECHNIQUE

Multiple antennas can be used at the transmitter and at the receiver of a communication system. Such systems are called multiple input and multiple output (MIMO) systems. MIMO systems may be implemented in several different ways and can be categorized into three types. The first type of MIMO system provides spatial diversity and enhances power efficiency. It includes space-time/frequency block code (STBC/SFBC), space-time trellis code (STTC) and delay diversity systems. The second type of MIMO system implements spatial multiplexing to increase its transmission rate. Independent data streams are transmitted over a group of antennas. At the receiver, signals from several antennas are detected and the transmitted information recovered. In the third type of MIMO system, some capacity gain can be achieved over non-MIMO systems by pre-processing the signals to be transmitted according to the channel characteristics and then decoding the received signals accordingly to the number of transmit (TX) antennas and the number of receive (RX) antennas, wireless systems can be classified as single-input single-output (SISO), single input multiple-output (SIMO), multiple-input single-output (MISO) and multiple-input multiple-output (MIMO) systems, in which the input and output are with respect to the channel between the transmitter and the receiver. The advantages of employing multiple antennas and related signal processing.



- **Array gain** As multiple copies of the signals are received at a receiver with more than one antenna, the signals can be combined coherently to achieve gain in effective SNR. Such gain is usually called array gain. Combining methods such as equal-gain combining (EGC) and maximal ratio combining (MRC) are very popular [3]. In an SIMO system, the average SNR increase is proportional to the number of receive antennas. In the case of multiple transmit antennas, however, array gain can also be obtained, provided that spatial pre-coding based on the channel information is

implemented. With this pre-coding, the multiple copies of transmitted signals supposedly will arrive at the single receiving antenna coherently.

- Diversity gain In a SISO system without signal redundancy, deeply faded signals are beyond detection. On the other hand, in wireless systems with multiple TX antennas and/or multiple RX antennas, signals can be transmitted/received with diversity so as to combat channel fading. Receive diversity in MIMO systems refers to the combination of independently faded signals from different receive antennas so that the processed signal suffers less fading than that of the receiver with only one antenna. Similarly, using coding that transmits redundant information from multiple TX antennas, transmit diversity can be achieved. Well known spatial coding techniques include space-time trellis codes (STTC) [4], space-time block codes (STBC) [5,6], space-frequency block codes (SFBC), and space-time-frequency block codes (STFBC) [7].
- Capacity gain MIMO technology brings one very important enhancement to wireless communications: gain in transmission rate. By multiplexing the transmitted data streams among different antennas, namely spatial multiplexing, an increase in data rate can be attained. This rate increase is proportional to the minimum of the number of TX antennas and the number of RX antennas. If either the transmitter or the receiver has a single antenna, then there exists no obvious capacity gain. Hence, spatial multiplexing is mainly applied to MIMO systems. Note that several data streams are simultaneously transmitted over the air and received at the RX antennas. At the receiver, these signals need to be processed to recover the information contained in the individual data streams.
- Beam forming When combining the received signals from multiple antennas, it is possible to create strong differentiation in gains for signals that arrive from different angles. The beam-forming technique [8] has traditionally been applied in the transmitter or the receiver to control the directionality of the transmit/receive antenna pattern. With proper knowledge of the channel and accordingly setting the combining coefficients, a beam forming receiver can increase the antenna gain along the direction of the intended transmitter while at the same time suppressing the interferences from other directions. Lured by these advantages, researchers have intensively studied the use of multiple antennas and, thus, this field has grown rapidly, both in theory and in implementation during the past few years [9]. The enhancement in spectral efficiency has resulted in the adoption of MIMO technology in several wireless standards. In this chapter, a brief introduction of channel capacity under different transmit/receive antenna configurations will be given first. Then, diversity gain attained by special signal arrangements in the spatial domain will be illustrated. Incorporation of the MIMO techniques into wireless OFDM systems will then be discussed. Moreover, this chapter will also cover how SISO OFDM transceivers

should be extended to enjoy MIMO advantages, especially in terms of synchronization and channel estimation. Finally, several MIMO encoding and detection schemes will be presented.

OFDM has the advantage of converting a wideband frequency-selective fading channel into numerous narrow-band flat-fading sub-channels. Hence, channel fading can be mitigated by a simple one-tap equalizer. On the other hand, MIMO techniques bring about a significant performance boost for wireless communications under flat-fading channels. As a result, by combining MIMO and OFDM, new high-speed wireless communication systems enjoy the benefits from both technologies[16,17].

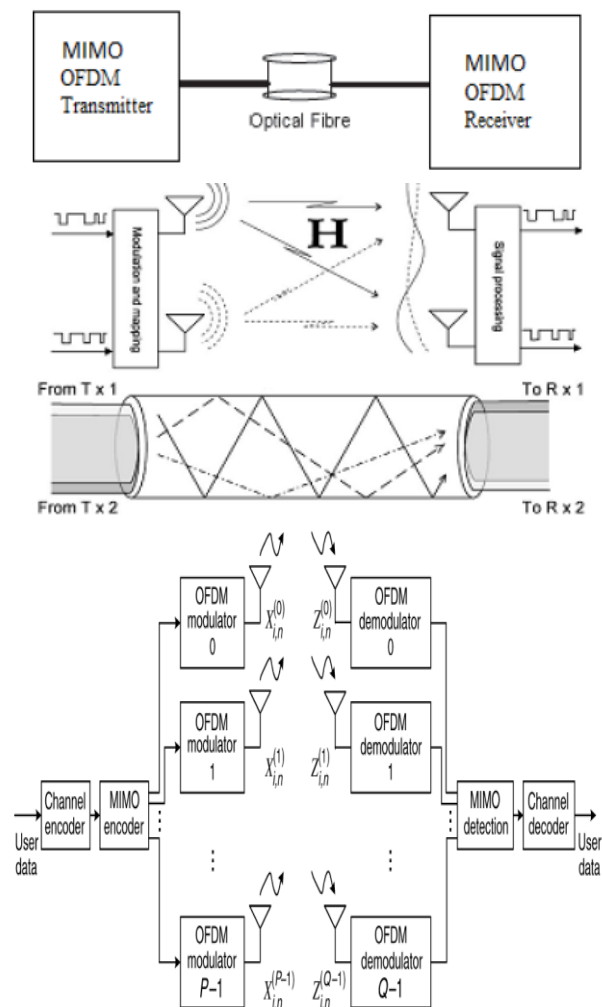


Fig. depicts a typical MIMO-OFDM system architecture with P transmit antennas and Q receive antennas. User data are first encoded by a channel encoder block, which may consist of one or more channel encoders. Afterwards, the MIMO encoder parses the data from the channel encoder block into several spatial streams. Recall that the signals transmitted by the OFDM transmitters can be represented on a symbol-subcarrier grid in the time-frequency plane. Now, in the MIMO-OFDM systems, a third spatial dimension is introduced, and, thus, the MIMO encoder output signals can be formatted in either space-time

blocks, space–frequency blocks or space–time–frequency blocks. Signals at different symbols and subcarriers but with the same space coordinate are fed into a single OFDM modulator, connected to its own transmit antenna.

#### IV. CONCLUSION

The maximum achievable diversity advantage of OFDM-MIMO system. In contrast to the conventional OFDM, the factor comes from the band hopping approach, which is regardless of the temporal correlation of the channel. In this paper the impact of a of OFDM and MIMO were assessed in the presence of future work. It was found that the systems are less robust to phase noise compared to their linear systems. it has been observed that strategies to find the truly significant receiving branches, during the data retrieving for a specific user, can be applied to reduce the complexity of the demodulation problem while maintaining and, even improving, the system performance. The results have also shown that aggregate high data rates can be obtained for indoor wireless optical communications at practical signal-to-noise ratios. These demonstrations show the suitability of optical OFDM in high-speed transmission systems with high spectral efficiency. Multi input Multi output is a very attractive technique for multicarrier transmission and become one of the standard choices for high speed data transmission over a communication channel. It has various advantages, but also has one major drawback i.e. Effect of noise within frequency selective fading channel In this paper we present Analysis for future work optical MIMO OFDM System using Different Modulation Schemes. In this paper we present a comparative study with inphase component to show the better noise reduction parameters.

#### REFERENCES

- [1] A. Paulraj, R. Nabar and D. Gore, Introduction to space–time wireless communications. Cambridge, UK: Cambridge University Press, 2003.
- [2] H. Yang, ‘A road to future broadband wireless access: MIMO–OFDM-based air interface’, IEEE Commun.Mag., vol. 1, Jan. 2005, pp. 53–60.
- [3] T. Eng, K. Ning and L. B. Milstein, ‘Comparison of diversity combining techniques for Rayleigh-fading channels’, IEEE Trans. Commun., vol. 44, Sep. 1996, pp. 1117–1129.
- [4] V. Tarokh, N. Seshadri and A. R. Calderbank, ‘Space–time codes for high data rate wireless communication: Performance criterion and code construction’, IEEE Trans. Inform. Theory, vol. 44, Mar. 1998, pp. 744–765.
- [5] S. Alamouti, ‘A simple transmit diversity technique for wireless communications’, IEEE J. Select. Areas Commun., vol. 16, Oct. 1998, pp. 1451–1458.
- [6] V. Tarokh, H. Jafarkhani and A. R. Calderbank, ‘Space–time block codes from orthogonal design’, IEEE Trans. Inform. Theory, vol. 45, no. 5, July 1999, pp. 1456–1467.
- [7] G. Bauch, ‘Space–time block codes versus space–frequency block codes’, in Proc. of IEEE Vehicular Technology Conference, vol. 1, Apr. 2003, pp. 567–571.
- [8] L. C. Godara, ‘Applications of antenna arrays to mobile communications, part II: Beam-forming and direction-of-arrival considerations’, Proc. of IEEE, vol. 85, Aug. 1997, pp. 1193–1245.
- [9] D. Gesbert, M. Shafi, D. Shiu, P. J. Smith and A. Naguib, ‘From theory to practice: an overview of MIMO space–time coded wireless systems’, IEEE J. Select. Areas Commun., vol. 21, no. 3, Apr. 2003, pp. 281–302.

- [10] G. J. Foschini and M. J. Gans, ‘On limits of wireless communications in a fading environment when using multiple antennas’, Wireless Personal Commun., vol. 6, Mar. 1998, pp. 311–335.
- [11] A. F. Molisch, M. Z. Win, and J. H. Winters, ‘Space-time frequency (STF) coding for MIMO-OFDM systems’, IEEE Commun. Lett., vol. 6, no. 9, pp. 370–372, Sep. 2002.
- [12] W. Su, Z. Safar, and K. J. R. Liu, ‘Towards maximum achievable diversity in space, time and frequency: Performance analysis and code design’, IEEE Trans. Wireless Commun., vol. 4, no. 4, pp. 1847–1857, Jul. 2005.
- [13] H. Al-Raweshidy, and S. Komaki, ‘Radio over-Fiber Technologies for Mobile Communications Networks’, Artech House, 2002.
- [14] J. Mitchell, ‘Performance of OFDM at 5.8 GHz using radio over fibre link’, Electronics Letters, vol. 40, No. 21, pp. 1353 – 1354, October 2004.
- [15] Sobia Baig, Fazal-ur-Rehman, M. Junaid Mughal, ‘Performance Comparison of DFT, Discrete Wavelet Packet and Wavelet Transforms, in an OFDM Transceiver for Multipath Fading Channel’, IEEE Communication Magazine, 2004
- [16] Deepak Gupta, Torry Harris, Vipin B Vats, Kamal K. Garg, ‘Performance Analysis of DFT-OFDM, DCT-OFDM and DWTOFDM in AWGN channel’, IEEE, The Fourth International Conference on Wireless Mobile Communications, 2007.
- [17] F. Farrukh, S. Baig, and M. J. Mughal, ‘Performance Comparison of DFT-OFDM and Wavelet-OFDM with Zero- Forcing Equalizer for FIR Channel Equalization’, IEEE Communication Magazine, 2008.

#### AUTHORS

**First Author** – Mridu Jain, M-tech scholar, B.T.I.R.T. Sagar (M.P.) email mridujain1990@gmail.com

**Second Author** – Ritu Dubey, M-tech, Asst Prof. B.T.I.R.T. Sagar (M.P.) email ritudubey2708@yahoo.com.

**Third Author** – Vishal Pasi, M-tech, Asst Prof. B.T.I.R.T. Sagar (M.P.) email pasivishal@yahoo.in



# The Economic and Socio-Cultural Balance Sheet of Tourism in Goa: Future Options

Dr. Savio P. Falleiro

Department of Economics, Rosary College of Commerce and Arts, Navelim, Salcete, Goa, India – 403 707

**Abstract-** Tourism is an important activity that has been present across the world for ages. Notwithstanding its numerous merits and benefits, tourism has its weaknesses and shortcomings too. This paper attempts to provide a balance sheet of the economic and socio-cultural impacts of tourism on Goa, a state in India known for its relatively tourism-centric economy. Based on the same and on experiences drawn from other tourism dependent regions across the country and the world, the paper draws a list of options for Goa for the future – options that would minimize the problems created by unplanned tourism while at the same time extracting the maximum that planned and responsible tourism can offer.

**Index Terms-** balance sheet, economic impact, Goa, socio-cultural impact; tourism

## I. INTRODUCTION

Travel and tourism is an important economic activity across the globe. While the total contribution of travel and tourism to GDP was US\$ 6,990.3bn or 9.5 percent of GDP in the year 2013, the total contribution to employment was about 265.86 million jobs, i.e. 8.9 percent of total employment in the same year (WTTC 2014, 3–4).<sup>1</sup> The tourism sector is one of the largest service industries in India. Goa is one of the states of India known for attracting tourists, both national and international. Having a population of about 1.5 million people, among other things Goa is known for its churches, temples, beaches, forts, music festivals, cuisine, cultural festivals etc. Goa is said to be India's richest state with a per capita income of two and a half times that of the country; and it was ranked the best placed state by the Eleventh Finance Commission for its infrastructure and ranked on top for the best quality of life by the National Commission on Population based on 12 Indicators (*Economic Survey 2013–14*, 22). Fourth smallest state in India in terms of population and smallest in terms of area, Goa has a coastline of about 105 kilometers. Having a total of about 269 kms of National Highways, one major port (besides five minor ports), one airport, besides rail connectivity, Goa is well connected to other parts of the country.

Goa generally ranks among the top 12 tourist destination states in India, albeit towards the bottom contributed to a large extent by its small size. The growth rate of tourism in Goa, was estimated to be 12 percent in 2013, higher compared to earlier years (*Economic Survey 2013–14*, 5 and 83).<sup>2</sup> According to provisional figures provided by the Department of Tourism, Goa received 3.12 million tourists in 2013, with 0.49 million being international tourists and about 2.63 million being domestic

tourists (*Economic Survey 2013–14*, 172). Large numbers of foreigners come to Goa as chartered tourists. In the year 2013 there were 1,128 charter flights landing in Goa, with 895 flights (almost 80 percent) being from Russia alone (Chari 2014, 1). While average amount spent by foreign tourists per day was found to be more than double the amount spent by domestic tourists (Datamation Consultants 2005–2006, ix and 70); according to a prominent hotelier and President of the tourism committee of Goa Chamber of Commerce and Industry (GCCCI), the average stay of a domestic tourist is 3 days as compared to 12 days of foreign tourists (see Fernandes 2014, 14). According to the report of Datamation Consultants (2005–2006), while major items of expenditure of domestic tourist's were found to be accommodation service at 30.4 percent, food at 30.35 percent and travel at 13.26 percent,<sup>3</sup> the main purpose of visit to Goa by domestic and foreign tourists was leisure. According to the same report most of the tourism in Goa is concentrated in the coastal stretches with over 90 percent of domestic tourists and over 99 percent of the international tourists frequenting these areas. While the total number of hotels in Goa is 2,777, with starred hotels being 49; total hotel rooms are 26,859, with starred hotel rooms being 4,519 (GIP 2014, 2).

Goa has witnessed drastic changes in the tourism sector ever since the advent of the hippies in the 70s. Over the years tourism has influenced the state, its economy and people in a very significant way. Though tourism was always an important industry in Goa, the focus on the same has nevertheless got all the more obvious and strong ever since the other major industry of Goa, mining, got shut down. The impact of tourism be it on Goa or on any other tourist dependent region, can be felt and observed from various dimensions. This paper attempts to draw a balance sheet of tourism in terms of its economic and socio-cultural impact on the state. Like a coin having two sides, so does tourism. The paper thus lists out the positive as well as negative implications of tourism. On the basis of the same the paper proposes towards the end options for the future keeping in mind the present scenario in Goa, as well as the experiences of other tourist dependent regions.

## II. B1. POSITIVE ECONOMIC IMPACT

Though not pertaining to Goa alone but to other tourist destinations as well positive economic implications of tourism include: increased tax revenue (Selvam 1989, 36; Negi 1990, 79); foreign exchange earnings (Negi 1990, 80–83; Kumar 1992, 89); increase in national income (Kumar 1992, 87–88); redistribution of national income (Negi 1990, 66; Kumar 1992, 91); operation of the multiplier effect (Mukhopadhyay 2010, 85;



Selvam 1989, 24–25; Seth and Bhat 1998, 15);<sup>4</sup> increase in household and cottage industries; increased employment and self employment; productive use of latent resources; increase in exports, etc. In addition to the above, other positive economic outcomes of tourism experienced by economies in general including Goa include, improved infrastructure, increase in retail businesses and small trade, increased income, improved standard of living, dispersion of development to non-industrial regions, etc. (Negi 1990; see also Kreag 2001, in Marzuki 2012, 201).

Leaving aside the nature and size of net gains, in terms of gross returns tourism has contributed its share to the Goan economy.<sup>5</sup> According to Kamat (2014) foreign exchange earnings from foreign tourist arrivals in Goa could hover between Rs 8,000 to Rs 15,000 crores annually. With reference to infrastructure, not only has it benefitted tourists, but the locals and for non-tourism purposes as well. With regards taxes, tourism has provided ample opportunities for the collection of direct and indirect tax revenue besides other fees. With reference to tax revenue, casinos alone contributed Rs 135.45 crore earnings in 2012–13.<sup>6</sup> It needs to be noted that Goa is one of two Indian states along with Sikkim (besides Daman which is an Union Territory) with legal casino gambling. The single window system for according permission for organizing ‘Tourism related events’ fetched the state Rs. 2.15 crores (*Economic Survey 2013–14*, 86). Likewise, while by issuing permissions for erection of huts, tents and temporary shacks in private properties for the tourist season 2013–14 the State earned revenue of Rs. 48.12 lakhs, by tendering parking lots located at Calangute and Mangueshi the government generated Rs. 60 lakhs (*Economic Survey 2013–14*, 86). In terms of employment, like the global scenario it is claimed that almost one in 10 jobs is directly or indirectly attributable to tourism. Not only is tourism by and large a labour-intensive industry (Selvam 1989, 38; Negi 1990, 74; Kumar 1992, 88; Seth and Bhat 1998, 4), it is also gender neutral in nature providing employment to a large number of women. While skilled and unskilled jobs are created, the elderly and housewives are also earning and self-sustaining via tourism by way of managing small shops and kiosks or renting rooms or two-wheelers.

### III. BII. NEGATIVE ECONOMIC IMPACT

As reported by many including Kreag (2001, in Marzuki 2012, 201) examples of negative economic consequences of tourism, be it on Goa or other tourist destinations, include: rise in cost of living (Kumar 1992, 92); leakages in income (Kamat 2014); rise in density of population (Solomon 2009, 2); high foreign exchange outflows; benefits to non-locals; artificial shortages; wasteful use of resources including water;<sup>7</sup> conversion of agricultural land; drop in agriculture<sup>8</sup> and traditional fishing as livelihood options; pressure of mass and unplanned tourism on infrastructure and natural resources;<sup>9</sup> etc.

One negative economic fallout of tourism has been rising prices and cost of living. Locals have often been ‘outriced’ in terms of land and daily consumption items like fish. While money-wielding tourists dictate the market, locals have invariably turned into foreigners in their own land – both because of dwindling numbers and lack of matching money power. In terms of employment, much of the same has gone to non locals,

with locals often getting lower rung jobs only. While the world over the local community generally is the primary beneficiary of the fruits of an activity like tourism, in Goa it has often been otherwise with the benefits often going to others including foreigners.<sup>10</sup> It needs to be mentioned here the dubious role played by foreign enclaves within the state as reported by local residents as well as media reports. While locals often sacrifice their land and aspirations and deal with adverse externalities of tourism including garbage (Monteiro 2014a, IV; Jha 2014, 8-9), congestion, rising cost of living and eye-sores like wayside cooking and open toilets, the benefits to a significant extent have gone to others.

Related to the issue, particularly of foreigners benefiting from tourism income, is the issue of leakages. While the tourism sector generally has a substantial multiplier, the same gets reduced in Goa due to various leakages, thus taking income out of the state with lesser net earnings to the local economy, local people and/or government. Leakages take place on account of various reasons including remittances made by foreign investors in Goa or due to increase in imports of tourism related goods not available locally. According to Kamat (2014) estimate of revenue leakage from tourism sector alone is annually Rs 1,200–1,500 crores which includes excise duties, VAT and entertainment tax. Though not with reference to Goa, UN statistics indicate that on an average only \$5 out of \$100 spent by foreign tourists actually stay in a developing country (ibid). The issue of leakages, multiplier and earnings gets compounded due to the mass advent of charter tourists to Goa, many of who pay major portions of their amounts payable abroad and not in Goa. A UN study on the economic effects of tourism in developing countries showed that about 80 percent of travelers expenses are paid to international companies by way of airline fares, hotel and tour reservations (ibid). Incidentally, chartered tourists are found to pay at times as low as \$15 per day only.

Though debatable, reports suggest, though technically may be incorrect, another leakage, i.e. expenses incurred by the government of Goa towards participation in tourism related road-shows, exhibitions and travel marts. These expenses are loosely considered a leakage since income or business generated due to such participation at least in certain places, is significantly less than the total expenses incurred. This is verifiable with the number of tourists arriving from such places (see also Verma 2014b, 1). Until recently half the foreign tourists coming to Goa were from Russia and UK alone and not from the other places where Goa participated. Often concerns raised by experts, citizens, academicians and others with regards to such expenses get summarily dismissed by authorities who unflappably state that the expenses incurred are ‘investments’. That they are or may not be investments can be seen though reports of the Comptroller and Auditor General (CAG). According to one report between 2007–12 Goa participated in 38 International Travel Marts (ITMs) and organized 15 road-shows worldwide spending Rs. 19 crores. However, no MOUs were signed during these shows/ITMs (Sen 2014).<sup>11</sup> Likewise, between August–November 2011, 14 road-shows were organized at Rs. 4 crores; while the same were expected to draw 150 tour operators and travel planners for participation in events and showcase Goa as a brand, only 25 to 64 participants turned up for the same (ibid).

#### IV. C1. POSITIVE SOCIO-CULTURAL IMPACT

Goa is becoming increasingly cosmopolitan – earlier because of its history and geography, now because of tourism. Some positive socio-cultural effects of tourism on Goa have been: conservation of cultural events, sites and skills; first-hand knowledge of foreign cultures; easy acceptance of social differences; removal of prejudices etc. Many art forms and traditions which would have gone extinct have been kept alive on account of tourism. Though one may call it neutral, there have been cases of marriages taking place between locals and tourists. These could in a way facilitate auto-assimilation of diverse cultures within the confines of the households itself. With the advent of tourism in a big way household decision making has often been found to shift away from the household head (usually a male) to others as well. With the financial empowerment provided by increased job opportunities to different household members by tourism, presence of multi-decision makers in a family (including females) is now not uncommon in Goa.

#### V. CII. NEGATIVE SOCIO-CULTURAL IMPACT

Some of the negative socio-cultural fallouts of tourism on Goa have been: commercialization of traditions; dilution of cultures; development of artificial culture; loss of identity; disruption of personal relations; rise in unhealthy competition; discontentment and uneasiness; forced changes and adjustments; changes in the local languages; demonstration effect; socio-culturally inappropriate imitation of foreign lifestyles; changes in food and local cuisine; destruction of heritage sites (sometimes in the name of tourism and beautification); denial of access to locals on beaches; unhealthy lifestyles; increase in lifestyle diseases, HIV infections, prostitution, pedophilia and trafficking; operation of mafias; disturbance in traditional family life; break-up of families due to issues like alcoholism, addiction to gambling, indebtedness and even suicides contributed by so-called tourist attractions like casinos etc. Tourism has brought in the feeling of estrangement among a large number of local residents, that too in their own locality. Villages that once housed 85 families now have to contend with mega housing projects which contain even 550 flats (Solomon 2009, 3). It is a fact that consumption behaviour, sleep patterns, grooming styles, genres of music, etc. have changed substantially in present times. Though these cannot be attributed to tourism alone, the role of tourism cannot be brushed aside. Faulty marketing often gets Goa wrongly portrayed as the place for easy availability and cheap alcohol, drugs and sex – and we get large number of tourists precisely for the same. Cultures, traditions, places and events of Goa are still not portrayed correctly by the government and/or stakeholders nor understood properly by tourists as can be seen by way of example half-naked tourists in religious places.

#### VI. D. OPTIONS FOR THE FUTURE

Tourism development has always been an integral part of the country's Five Year plans, with the National Tourism Development Policy, 2002, aiming to position tourism as a major engine of economic growth and to harness its direct and multiplier effects for employment and poverty eradication in an

environmentally sustainable manner.<sup>12</sup> In spite of the importance accorded to tourism, and with India relying on tourism for around 7 percent of its economy, of late visitor numbers have dropped; in 2013 India attracted less than 7 million tourists, compared with cities like London, which had twice as many (Kannan 2014); with countries like Thailand receiving 26.5 million and China 55.7 million tourists (Sequeira 2014a, IV). For the same year our share of tourists was just 0.64 percent of the global figure, ranking us 42<sup>nd</sup> in the world compared to number 4 of China (ibid). Incidentally, compared to the 6.97 million foreign tourists that India received in 2013, nearly two and a half times that number (16.63 million) Indians travelled abroad (ibid). Despite its merits, tourism is highly unpredictable. Epidemics,<sup>13</sup> recession, terror threats, exchange rate changes,<sup>14</sup> conflicts,<sup>15</sup> competition,<sup>16</sup> or even rumours can cause drastic fall in arrivals. Failure of tourism, with no alternative to fall back on, can lead an economy into disaster. Goa, with substantial amount of haphazard, unplanned and volumes-alone-focused mass-tourism can be potentially heading for the same, unless appropriate measures guided by focused short and long term vision documents are in place. During December 2014, peak season for tourism in Goa, stakeholders are bitterly complaining of drastic fall in foreign tourist arrivals. While occupancy in hotels took a hard hit (Verma 2014c, 1),<sup>17</sup> luxury resorts were resorting to rate cuts (Sequeira 2014b, 2), stakeholders were contemplating shutting down businesses like beach shacks as early as in January 2015 (Verma 2014c, 1),<sup>18</sup> with many not having enough money to pay suppliers and workers like waiters and cooks (Chari et al 2014, 1), or paying them with their personal funds (Verma 2014c, 1).

For various reasons tourism often gets a disproportionate onus of shouldering Goa's economic needs. Goa is said to be targeting 5 million tourists in 2015–17, with 4 million arrivals expected on account of the Exposition of St. Francis Xavier (Verma 2014a, 8). Can Goa cater to more tourist foot-falls? The challenge is all the more since with Goa becoming a famous hub, numerous mega events often happen in the state, that too more or less at the same time, particularly between November and February.<sup>19</sup> Though may be contra-argued by some, in terms of Tourism Carrying Capacity analysis<sup>20</sup> it appears that Goa can manage more tourists at least in the near future (IL&FS 2012, 20–21), albeit with more focused planning and increased investments to take care of needs like better roads, changing rooms, waste treatment and management,<sup>21</sup> toilets, parking etc (IL&FS 2012).

In the context of the socio-eco-cultural impact that tourism has borne on Goa, what could be the way forward for the tourism sector? While certainly worthy initiatives have been taken by the government, Goa Tourism Development Corporation (GTDC) and others in shaping the industry, much still needs to be done so that we do not prematurely burst the bubble through unplanned and haphazard growth and overdependence. Initiatives that could help bolster tourism in Goa are as follows (these are listed on the basis of the existing socio-economic-cultural status of Goa vis-à-vis tourism and experiences of other tourism dependent regions):

(1) *Promote Community-based Eco-Tourism*: Sustainable, just and equitable; done successfully in many places including Kerala.

(2) *Promote Medical Tourism*: Viable for Goa/India and carries a higher multiplier value than regular tourism. According to 'Facts of Medical Tourism' provided by Bubna (2013, 101–102), millions of patients travel to other countries for Medical Tourism each year, with a June 2009 MTA Patient Survey finding almost 83 percent of patients traveling with a companion, with almost 90 percent of patients or their companions engaging in tourism activities.

(3) *Have a comprehensive model Charter / Code of Tourism*: Needed to keep systems in place and to encourage responsible tourism. Responsible tourism is that which aims to minimize adverse environmental and socio-cultural impacts, and generate greater economic benefits for the locals (ICRT 2003, in Weeden 2005). To begin framing a model charter for Goa, charters of other places across the world could be used as starting blocks – the same could then be recast and (re)modeled to suit local needs, aspirations and vision.

(4) *Promote Family-oriented Tourism*: Goa's Director of Tourism agrees that encouraging Goa as a family destination will help curtail the menace of unruly public behavior on account of increasing domestic tourists many of whom are all-male groups (Shrivastava 2014, II).<sup>22</sup> Family oriented tourism can also reduce evils of mass tourism like prostitution and pedophilia; besides adding days of stay (and help the local economy earn more income).

(5) *Promote Heritage / Pilgrimage / Religious Tourism*: Appropriate for Goa as the state has got rich history and architecture in addition to forts, rock carvings, temples, churches, etc. With the richness that Goa possesses, the same is an excellent option to divert tourists away from the overcrowded and oversaturated coastal belt.

(6) *Promote Adventure, River, Hinterland, Cruise and MICE Tourism*: The first three are excellent as community based eco-tourism initiatives. Incidentally, Goa has 255 kms of navigable internal waterways (GIP 2014, 2), besides one major port and five minor ports. Needless to say, infrastructure which we are substantially deficient in (see IL&FS 2012) has to be fast put in place. Incidentally, with regards to cruise tourism, poor infrastructure contributed to its slump in Goa;<sup>23</sup> the number of liners arriving dropped from 25 in 2011–12 to 17 in less than three years, with a 50 percent drop in overseas visitors (Sequeira 2014a, IV).

(7) *Put a selective cap on foreign tourists*: This should be done at least in the peak season on the basis of minimum amount to be spent per day: Those foreign tourists who cannot spend the pre-determined minimum amount should not be encouraged to Goa. Considering the small size of Goa these tourists are of no significant value to the economy; on the contrary they could be of nuisance value in terms of garbage, congestion, extra load on limited and fragile infrastructure etc.

(8) *Deal firmly with foreigners illegally usurping benefits at the cost of the locals*: Whether it is tourist transport, guides or otherwise, few foreigners are often accused in Goa for doing business illegally at the lost of the locals. While the same should be clamped down, so should foreign enclaves set up on local soil.

(9) *Have a realistic plan – and planning forwards*: i.e. from basic requirements to final project or activity. Often the reverse happens in Goa, for example, water sports. While the same is more-often-than-not organized in a haphazard manner in

different beach areas, endangering the lives of both the water sports enjoying tourists as well as of the passive passersby, guidelines for the same come into the picture only when an ugly accident or tragedy occurs. Why cannot guidelines be in place before permissions are given to start such activities? Besides locals, not having realistic plans or guidelines can have an adverse bearing on tourists themselves.

(10) *Initiate faster decision making*: This does not always happen – affecting stakeholders and tourists alike. Two instances by way of examples are as follows: (a) grant of licences for beach shacks often gets delayed by even a month into the tourist season; and (b) issue of license for the EDM festival *Sunburn* was kept pending for 11 months in spite of the organizers having successfully organized the event for seven years attracting huge crowds and supposedly pumping an estimated Rs 500 crores into the local economy.<sup>24</sup>

(11) *Provision of basic tourism infrastructure*: Like signages, roads, drinking water, parking, resting facilities, changing rooms, waste management etc. There is much to be desired in Goa on the said fronts (see also Jha2014, 8-9; Chari et al 2014, 1; IL&FS 2012); while some roads are basically those which existed decades ago, measures for disposal and treatment of waste, garbage and sewage are as good as absent, with the beach area itself littered with heaps of waste. Leaving aside signages in different languages required to cater to the needs of multi-regional and lingual tourists, there are more-often-than-not no signages even in English, Hindi (national language) or Konkani (local language).

(12) *Consultative and participatory process involving all stakeholders and locals*: The success of tourism entirely depends on the same.

(13) *Initiate strict monitoring and quick justice*: Websites promoting sex-tourism;<sup>25</sup> spas/beauty parlors (often acting as fronts for prostitution); outlets dispensing drugs,<sup>26</sup> etc. need to be firmly and quickly clamped.

(14) *Address without delay and political compulsions issues which affect tourism*: Unfortunately does not always happen in Goa, for example, the issue pertaining to tourist taxis. While as per natural just order the local taxis drivers (and not foreigners) should get the right to tourism transport business; at the same time allegations raised against them in terms of overcharging and strong arm tactics (see also Monteiro 2014a, IV) should be firmly tackled without delay.

(15) *Protect, encourage and involve the local community*: Promote home stays and small and medium guest houses; don't equate beach shacks with big hotels. All this will encourage local entrepreneurs and reduce leakages. At present there are accusations that shacks (run basically by locals) which are Goa's best ambassadors, are treated like pariahs by the government (Gupta 2014, 2); not only is there a delay in issue of licences, but there is no level playing field as well between shacks and class hotels. For example while registration fees for a class hotel is Rs. 5,000 across categories irrespective of rooms, the fees for non AC huts in beach shacks is Rs 3,000 and Rs 5,000 for AC huts (ibid).

(16) *Publicize and promote lesser known sites*. Though Goa is small, there are still many less known places of tourist interest, including beaches (IL&FS 2012, 3 & 22).



(17) *Have pro-active, tourist friendly, internationally competitive, efficient delivery and availability of tourist requirements:* At present Goa is plagued with high taxes,<sup>27</sup> high airport charges, lack of parking space for planes and motor vehicles, high visa charges, too many formalities etc. Presently with the cost of visas being so high, a family visiting Goa needs to shell out close to Rs. 50,000 on visas alone. Poor facilities made Condor Airlines,<sup>28</sup> operating for over three decades and bringing approximately 25,000 German tourists during a single season, to pull out from the state (see Monteiro 2014b, III).

(18) *Streamlining collection of taxes, fees etc:* Very important especially considering that Goa is generating a lot of tourist footfalls. In spite of the same generation of income to the public treasury is a matter of concern (see also Kamat 2014). Whether it is EDM festivals, accommodation units or other businesses, there are allegations of mismanagement, incorrect estimation of taxes, under-collection, corruption, nepotism and/or poor recovery that denies the state its rightful share of revenue in terms of taxes and fees.

## VII. E. CONCLUSION

For the success of good, responsible and sustainable tourism, tourism cannot be treated only in terms of commoditization of the tourist product, which unfortunately often is the case. While these artificial stances may provide a few photo-ops for tourists and help rake in earnings for the local stakeholders and economy in the short run, in the long run the same will not work as various destinations vie for the same footfalls of the tourists. To sustain tourism in the long run service providers need to deliver the 'real Goa experience' to the tourists – for anything else that we may try to offer, is already available elsewhere. Tourism is not just about numbers...it's about the quality of the numbers and the sustainability of the sector... (Sequeira 2014a, IV). Too many hotels are built and Goa is losing its charm...we do not need shopping malls, golf courses, private beaches or huge hotels...we need Goa to be Goa which is unique, not a copy of the West Indies or Thailand (Monteiro 2014a, IV). If the unique Goan environment (the primary reason why Goa has become a brand and why tourists come to Goa) is destroyed, so also will tourism – as other destinations will be more attractive and even cheaper (Chari et al 2014, 1). To put thing in perspective, in the words of a tourist (made in the context of the standard offered and cost of four and five star hotels in the state) '*...in Thailand I can get rooms in better hotels for half the price*' (in Monteiro 2014a, IV).

## VIII. NOTES

1. While the contribution to GDP was expected to grow by 4.3 percent to US\$ 7,289.1bn (9.6 percent of GDP) in 2014, the contribution to employment was forecast to rise by 2.5 percent in 2014 to about 272.42 million jobs, i.e. 9 percent of total employment (WTTC 2014, 3–4).
2. See also: Dept. of Tourism, Govt. of Goa, 22/01/2014: <http://www.goatourism.gov.in/travel-news/details/106/248>

3. According to Kamat (2014) as per previous surveys foreign and domestic tourists spend about 50 to 55 per cent of their money on food and beverages.
4. There are many types of multipliers related to tourism, including those pertaining to Employment, Sales, Income and Output. Additionally, reference can also be made to Direct, Indirect and Induced multiplier effects.
5. Unfortunate one may say, while the state planning department has admitted that it has no formula to capture contributions of tourism sector to the state domestic product (GSDP), the state planning department has failed to come out with a realistic assessment of the economic intensity in the tourism sector (Kamat 2014).
6. Retrieved from: [http://articles.economictimes.indiatimes.com/2013-04-13/news/38511289\\_1\\_crore-licence-fee-entry-tax](http://articles.economictimes.indiatimes.com/2013-04-13/news/38511289_1_crore-licence-fee-entry-tax)
7. For example while low budget hotels need 573 litres of water per room per day, luxury hotels need 1,335 liters per room per day on account of landscaped areas, swimming pools and number of restaurants (Solomon 2009, 2).
8. It has been found that over 50 percent of households in certain parts of North Goa have left their lands to lie idle without tending/cultivating them on account of tourism (Solomon 2009, 5).
9. Destruction of sand dunes and presence of toxic elements in well water have often been reported.
10. Estimates show that about 65 percent of rent-backs are owned by non-resident Goans, 20–25 percent by Goans from other Indian cities and only 10–15 percent by natives residing in Goa (Solomon 2009, 5).
11. See also: <http://www.heraldgoa.in/Goa/Finally-a-new-language-in-tourism-spending-A-for-accountability-/77187.html>.
12. See: Competitiveness of Tourism Sector in India with Selected Countries of World: Final Report. Ministry of Tourism, Government of India. AC Nielson ORG-MARG; retrieved from: <http://tourism.gov.in/writereaddata/CMSPagePicture/file/marketresearch/studyreports/IndiaTourismGlobalpercent20.pdf>
13. Be it threat of Ebola, or even plague as was witnessed some years back in Surat.
14. This led to drastic drop in Russian tourists to Goa during 2014.
15. Drop in tourists from Ukraine as a result of the ongoing conflict is a recent example.
16. From international destinations like Thailand, Malaysia, Singapore, Sri Lanka and from local destinations like Kerala.
17. Occupancy in hotels and guest houses around Christmas time was even less than 50 percent in some hotels/guest houses – something unheard of in Goa with full occupancy otherwise being experienced during the entire Christmas–New Year period.
18. Regular tourism season in Goa otherwise extends to around May.

19. During this period festivals/events that attract hordes of tourists include the International Film Festival of India (IFFI), two to three Electronic Dance Music (EDM) festivals, Feast of St. Francis Xavier, Christmas, New Year eve, New Year, Carnival, etc.
20. Citing Alvin Chandy, IL&FS (2012, 15) defines TCC as 'the maximum number of people that may visit the tourist destination without causing destruction of the physical, economic and socio-cultural environment and an unacceptable decrease in the quality of visitors' satisfaction'; TCC is an assessment based on three major indicators: Physical-Ecological, Socio-Demographic and Political-Economic (ibid).
21. Solomon (2009, 5) reports that only 11 percent of the high-budget and 67 percent of the luxury hotels were able to treat their sewage in treatment plants, with a large number of enterprises disposing their sewage in soak-pits or tanks.
22. According to sex classification of tourists in Goa, 68.45 percent of total tourists were male; relatively similar findings were observed for domestic as well as foreign tourists (Datamation Consultants 2006, viii).
23. See: *The Times of India*, 1<sup>st</sup> September 2014, 5.
24. See: *Herald*, 29<sup>th</sup> December 2014, 9; 'The burning issue under the sun'
25. As per a report appearing in the local daily *The Navhind Times* (23<sup>rd</sup> November 2014), the websites even mention the fees for sex services with charges ranging from Rs 20,000 to Rs 3 lakhs; according to one website 'Call girls include Russian, Spanish and also from the modelling field in Goa including local Goan for escorts'. Retrieved from: <http://www.navhindtimes.in/high-end-prostitution-racket-busted-2-held/>
26. Dispensation of drugs is widely reported in the media. By way of example see: 'There are organized drug gangs everywhere: Wagh' and 'Drug gangs are a part of Goa's ecosystem. Why deny this?', both in *Herald* (25<sup>th</sup> December 2014, 1 & 8).
27. See also *Herald*, 25<sup>th</sup> Dec 2014, 6; under 'Tourists' Footfalls'.
28. Direct flight from Frankfurt to Goa.

#### REFERENCES

- [1] Bubna, P. 2013. Multiplier effect in medical tourism: A case study reference to Rajasthan. *Asia Pacific Journal of Marketing & Management Review*. Vol. 2(1): 100–111. <http://indianresearchjournals.com/pdf/APJMMR/2013/January/9.pdf>
- [2] Chari, B. 2014. Goa will get just 500 charters from Russia. *The Times of India*. 24th October.
- [3] Chari, B., N. Sequeira and J. Zuzarte. 2014. Joy to the world but sorrow for Goan tourism. *The Times of India*, 24th December.
- [4] Datamation Consultants. 2005–2006. Collection of domestic tourism statistics for the state of Goa: Final report (April 2005 to March 2006). Submitted to the Ministry of Tourism, Government of India. Retrieved from: <http://tourism.gov.in/CMSPagePicture/file/marketresearch/statisticalsurveys/03percent20goa.pdf>
- [5] Economic Survey 2013–14. Directorate of Planning, Statistics and Evaluation, Government of Goa.
- [6] Fernandes, R. 2014. Goa tourism development corporation: Boosting brand Goa. *Business Goa*. Vol. 6(4):14–16.
- [7] GIP / Goa Investment Policy. 2014. Goa-Partnering for progress. Government of Goa. [http://www.goaditc.gov.in/Goa\\_Investment\\_policy\\_18\\_June\\_2014\\_v56.pdf](http://www.goaditc.gov.in/Goa_Investment_policy_18_June_2014_v56.pdf)
- [8] Gupta, S. 2014. What is a tourism master plan worth when you treat your shack owners as pariahs? *Herald*. 21st September.
- [9] ICRT / International Centre for Responsible Tourism. 2003. Responsible tourism. <http://www.icrtourism.org/resp.html>
- [10] IL&FS. 2012. Identification of tourism circuits across India: Interim report Goa. [Presented to Ministry of Tourism, Govt. of India]. Retrieved from: <http://tourism.gov.in/writereaddata/CMSPagePicture/file/marketresearch/Te ntatively percent20Identified percent20circuit percent20for percent20various percent20states/new/goa.pdf>
- [11] Jha, N. 2014. Goa is still stinking. *The Goan*. 25th October.
- [12] Kamat, N.M. 2014. Tax Evasion Rampant in Tourism Sector-I. *The Navhind Times*, 29th December. <http://www.navhindtimes.in/tax-evasion-rampant-in-tourism-sector-i/>
- [13] Kannan, S. 2014. Reversing India's falling tourism numbers. *BBC News*. 15th August. <http://www.bbc.com/news/business-28801550>
- [14] Kream, G. 2001. The impacts of tourism. Minnesota Sea Grant. <http://www.seagrant.umn.edu/tourism/pdfs/ImpactsTourism.pdf>
- [15] Kumar, M. 1992. *Tourism today: An Indian perspective*. Delhi: Kanishka Publishing House.
- [16] Marzuki, A. 2012. Local residents' perceptions towards economic impacts of tourism development in Phuket. *Tourism*. Vol. 60(2): 199–212. Retrieved 29th December 2014, [hrca.hr/file/125947](http://hrca.hr/file/125947)
- [17] Monteiro, Lisa Ann. 2014a. Is Goa dead? *Herald Review*. 28th December.
- [18] Monteiro, Lisa Ann. 2014b. It's a sad story. *Herald Review*. 28th December.
- [19] Mukhopadhyay, Sipra. 2010. *Tourism Economics*. New Delhi: Ane Books.
- [20] Negi, J. 1990. *Tourism and travel: Concepts and principles*. New Delhi: Gitanjali Publishing House.
- [21] Selvam, M. 1989. *Tourism industry in India*. Bombay: Himalaya Publishing House.
- [22] Sen, S. 2014. Goa ministers spent Rs 19 Cr holidaying abroad: CAG expose by CNN-IBN. Available at: [http://www.goanews.com/news\\_disp.php?newsid=5091](http://www.goanews.com/news_disp.php?newsid=5091)
- [23] Sequeira, D. 2014a. Flights of fancy. *Herald Review*, 28th September.
- [24] Sequeira, N. 2014b. Luxury resorts compromise on rates to attract guests. *The Times of India*, 24th December.
- [25] Seth, P.N and Bhat S.S. 1998. *An introduction to travel and tourism*. New Delhi: Sterling Publishers Pvt. Ltd.
- [26] Shrivastava, N.A. 2014. Focus on Family Destination. *Herald Review*, 21st September.
- [27] Solomon, R. 2009. The challenge and prospects of tourism in Goa today [initiative of Alternatives, Equations, CSJP and Centre for Responsible Tourism] Panaji: CSJP.
- [28] Verma, V. 2014a. Implementation of the full tourism plan will take five years. *Herald*, 21st September.
- [29] 2014b. Poor tourist season pepped up a bit on Christmas day. *Herald*, 26th December.
- [30] 2014c. Drop in tourist arrivals hits Morjim, Ashwem. *Herald*, 27th December.
- [31] Weeden, C. 2005. Ethical tourism: Is its future in niche tourism? In Marina Novelli edited, *Niche tourism: Contemporary issues, trends and cases*. Oxford, UK: Butterworth-Heinemann. Pp 233–245. Available at: [http://www.academia.edu/762865/Ethical\\_tourism\\_Is\\_its\\_future\\_in\\_niche\\_tourism](http://www.academia.edu/762865/Ethical_tourism_Is_its_future_in_niche_tourism) (accessed in March 2013).
- [32] WTTC / World Travel & Tourism Council. 2014. Travel & tourism: Economic impact 2014 – World. [www.wttc.org/media/files/reports/.../regional%20reports/world2014.pdf](http://www.wttc.org/media/files/reports/.../regional%20reports/world2014.pdf)



AUTHORS

**First Author** – Dr. Savio P. Falleiro, Vice Principal, Associate Professor, Head - Department of Economics, Rosary College of Commerce and Arts, Navelim, Salcete, Goa (India) – 403 707; Mobile No. 09422060384; Email: [saviofalleiro@gmail.com](mailto:saviofalleiro@gmail.com)

# A Rare Case Report of Guillian Barre Syndrome Presenting with Unilateal Facial Nerve Palsy

Dr. B. Suryanarayana\*, Dr. R. Siddeswari\*\*, Dr. B. Sudarsi\*\*\*, Dr. S. Manohar\*\*\*\*, Dr. Pramod\*\*\*\*\*

\* M.D., Asst Prof. of Medicine, Osmania General Hospital, Hyderabad, Telangana State, India.

\*\* M.D., Prof. of Medicine, Osmania General Hospital, Hyderabad, Telangana State, India.

\*\*\* M.D., Asst Prof. of Medicine, Osmania General Hospital, Hyderabad, Telangana State, India.

\*\*\*\* M.D., Professor & HOD of Medicine, Osmania General Hospital, Hyderabad, Telangana State, India.

\*\*\*\*\* (M.D). PG, Osmania General Hospital, Hyderabad, Telangana State, India.

**Abstract-** Gullian Barre Syndrome is an acute diffuse post infectious demyelinating disorder of spinal roots and peripheral nerves and occasionally cranial nerves. Bilateral facial nerve palsy is the most common pattern of cranial nerve involvement in GBS. However, unilateral facial palsy, although uncommon, can be seen in GBS. We report a rare case of unilateral facial palsy in a patient with Gullian Barre Syndrome.

**Index Terms-** Gullian Barre Syndrome, facial nerve palsy, Acute Inflammatory Demyelinating Polyneuropathy.

## I. INTRODUCTION

The Guillian - Barre Syndrome is one of the commonest forms of polyneuropathy. The reported incidence rates for GBS are 1-2 per 1 00,000 population. The lifetime likelihood of any individual acquiring GBS is 1 in 1000. Available Indian literature indicates a peak incidence between June, July and September - October. In the Western Countries GBS is common in the 5<sup>th</sup> decade, but in India it occurs more commonly in younger age. GBS is equally common in men and women and can occur at any age. There is a male preponderance among the hospitalized population.<sup>1</sup>

Gullian Barre Syndrome also known as an Acute Inflammatory Demyelinating Polyneuropathy (AIDP) is an acute demyelinating polyradiculopathy of uncertain aetiology which may present with facial nerve involvement in 27-50% of cases, often bilaterally<sup>2</sup>.

Over half of Gullian Barre syndrome patients experience symptoms of viral respiratory or gastrointestinal infections during the 1-3 weeks prior to the onset of neurological symptoms. Clinical criteria, spinal fluid protein elevation, and nerve conduction abnormalities are the mainstay of diagnosis<sup>3</sup>.

## II. CASE PRESENTATION

A 70 year old male patient presented with weakness of both upper limbs and lower limbs, inability to close left eye, history of pins and needle sensation on both hands and feet of 1 week duration.

**Past History:** No History of trauma, Hypertension, Diabetes, CAD, Dog bite, recent vaccination and no previous significant neurological problems.

**Personal History:** Takes mixed diet, smoker, occasional alcoholic.

**General Examination:** About 70 year old Lean male with pulse rate 80/mt regular, temperature normal, no neck stiffness, Respiratory Rate 18/mt, BP – 130/80 mm Hg.

**Neurological Examination:** Intellectual functions normal, slurring of speech present, Bells phenomenon on left eye, deviation of angle of mouth to right while talking suggestive of left lower motor nerve type facial palsy, all other cranial nerves are normal.

**Motor system:** Bulk – Normal; Hypotonia of all 4 limbs, with Power 2/5 in all four limbs.

**Superficial reflexes:** Corneal, conjunctival, abdominals are present, plantars flexors through out the course of illness.

**Deep tendon reflexes** are absent in all four limbs, sensory system examination is normal, fundus is normal; No bladder and bowel involvement.

No Cerebellar signs, skull & spine are normal. No signs of meningeal irritation

Patient was treated with high dose IV steroids for 5 days with which power in all four limbs improved and power in all limbs at discharge is 4/5. Patient is advised regarding protection of eye during sleep and massage of the weakened muscles. Patient is on regular follow up. Patient is able to walk without support but unable to close the left eye is persisting.

### Investigations:

Complete Urine Examination : Albumin :nil, Sugar: nil, Bile salts, Bile Pigments :nil, 1 to 2 epithelial cells/hpf.

Complete Blood Picture: Hb:13.5, Wbc:7200, Neutrophils : 68, Lymphocytes:28, Monocytes:2, Eosinophils: 02, Platelets: adequate, ESR:05, RBS:90, Serum urea:20, Serum creatinine:1, Serum electrolytes: Sodium:138, Potassium:3.6

HIV and HBsAG negative

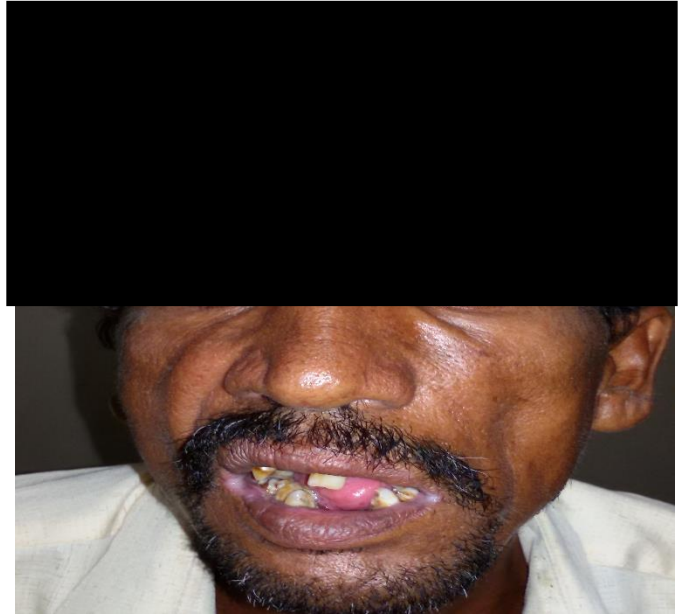
CSF analysis : Proteins – 51 mg/dL ; Sugar - 80 mg/dL ; ADA – 06 U/L ; No cells seen; culture – negative

MRI BRAIN – Normal Study.

**Nerve Conduction Studies:** Sensory Motor Axonal Demyelinating neuropathy with Radicular involvement

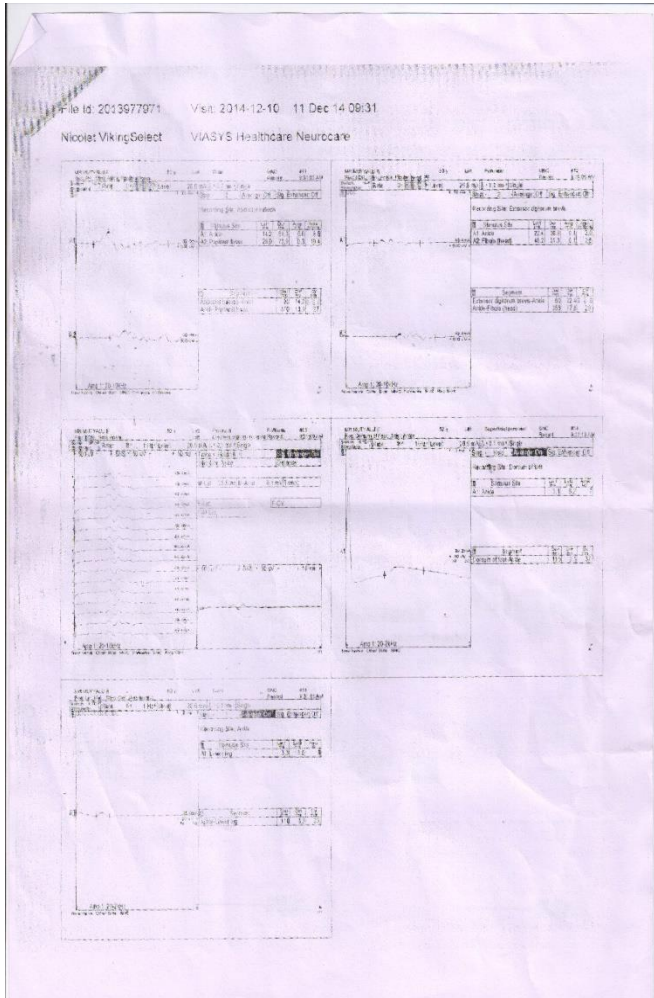


Bells Phenomenon of left eye



Deviation of Angle of Mouth to Right & loss of Nasolabial fold on left side

**Electro physiological Studies (Nerve Conduction Report)**



R1:	N2:	R2:	Area	Segment	Diff (ms)	Dist (mm)	NCV (m/s)
				- WRIST (MED)			
				WRIST (MED) - ELBOW			
				ELBOW - WRIST (ULN)			
				WRIST (ULN) - ELBOW			
0.6	mV	2.9	mVms	-			
0.6	mV	2.7	mVms	ANKLE (PTN) - KNEE	11.36	390	34.33
0.5	mV	1.9	mVms	-			
0.4	mV	2.3	mVms	ANKLE (CPN) - KNEE	9.37	350	37.35

R1:	N2:	R2:	Area	Segment	Diff (ms)	Dist (mm)	NCV (m/s)
				- WRIST (MED)	2.71		
				WRIST (MED) - ELBOW	5.21	270	51.82
				ELBOW - WRIST (ULN)	5.63		
				WRIST (ULN) - ELBOW	5.52	300	54.35
				-			
				ANKLE (PTN) - KNEE	11.15	390	34.98
				-			
				ANKLE (CPN) - KNEE	8.95	350	39.55

N2:	R2:	Area	Segment	Diff (ms)	Dist (mm)	NCV (m/s)
			Ankle - Mid Calf			
			Ankle - Mid Calf			

N2:	R2:	Area	Segment	Diff (ms)	Dist (mm)	NCV (m/s)
			Digits - Wrist	2.63	140	53.44
			Digits - Wrist	2.25	110	48.89

N2:	R2:	Area	Segment	Diff (ms)	Dist (mm)	NCV (m/s)
			Ankle - Mid Calf			
			Ankle - Mid Calf			

R1:	Extensor Digi Brevis	S:	Ankle
an Lat (F-M)	Lat	Distance	Velocity

Amsan

### III. DISCUSSION

The Guillain Barre Syndrome produces a relatively symmetrical areflexic tetraparesis. In three quarters of patients, the first neurological symptom is of paraesthesiae in the toes, less often in the fingers.

Muscle weakness usually starts in the legs and ascends to the arms. Proximal muscle weakness may be prominent from the onset. The weakness is fairly symmetrical and usually involves the trunk musculature. Maximal weakness generally develops within 12-14 days of the onset of neurological symptoms. Although cessation of symptom progression within 4 weeks is often regarded as a necessary criterion for the diagnosis of Guillain – Barre Syndrome (Asbury and Cornblath 1990).

Tendon reflexes are usually lost early in the disease. Total areflexia occurs in over 80 per cent of patients at some stage of the illness. Approximately half the patients develop cranial – nerve palsies, usually in the wake of severe ascending limb weakness (*Loffel Rossi, Mumenthaler, et al 1977 ; Winer, Hughes, and Osmond 1988*). Isolated unilateral or bilateral facial palsy is the commonest cranial – nerve lesion in Guillain – Barre syndrome.

Bulbar palsy and weakness of the muscles of mastication are the next commonest cranial nerve abnormalities. Ocular palsy only occurs in about 10 per cent of patients<sup>3</sup>.

Laboratory Findings: The most important laboratory aids are the electro diagnostic studies and the CSF examination. The CSF is under normal pressure and is cellular or contains only a few lymphocyte in all. In few patients (10 percent or less), the CSF protein values are normal throughout the illness.

Nerve conduction studies are a dependable and early diagnostic indicator of GBS, and in instances with a typical clinical and EMG presentation, one can dispense with the CSF analysis. The most frequent early findings are a reduction in the amplitudes of muscle action potentials, slowed conduction velocity, or conduction block in motor nerves. Prolonged distal latencies (reflecting distal conduction block) and prolonged or absent F response (indicating affection of proximal parts of nerves) are other important diagnostic findings, all reflecting demyelination<sup>4</sup>.

Most patients with the Guillain Barre Syndrome will make a good spontaneous recovery if they receive competent supportive treatment.

GBS treatment should be initiated as soon after diagnosis as possible. Either high-dose intravenous immune globulin (IVIg) or plasmapheresis can be initiated. IVIg is administered as five daily infusions for a total dose of 2 g/kg body weight<sup>5</sup>.

### REFERENCES

- [1] AK Meena 29th Chapter, Peripheral Neuropathy, API Text Book of Medicine, 9th edition Vol. II Jaypee Brothers Med Publishers, (Pg No. 1533)
- [2] Kilic R, Ozdek A, Felek S, Safak MA, Samim E : A case presentation of Bilateral Simultaneous Bell's Palsy. American Journal of Otolaryngology 2003, 24 (4) : 271 – 273.
- [3] Micheal Donoghy ; Disorders of Peripheral nerves Chapter 18th ; Acute Idiopathic Polyneuritis 18.25; Brain's Disease of the Nervous System 10th Edition ; Published in the United States of Oxford University Press Inc., New York (Pg no. 599 – 601).

- [4] Maurice Vitor, M.D., & Allan H Ropper, M.D., ; Chapter 46, Diseases of Peripheral Nerves ; Adams & Vectors, Principles of Neurology 7th Edition; Mc. Graw - Hill Medical Publishing division. (Pg No.1381-1382).
- [5] Anthony A. Amato, Richard J. Barohn 384th Chapter Peripheral Neuropathy, Harrison Text Book of Medicine 18th Edition, Vol II Graw Hill Publishers, 2012, Pg 3448.

#### Case Reports :

- [6] Unilateral facial palsy in Guillain Barre Syndrome (GBS) : A rare occurrence, Department of Neurology, Chhatrapati Shahuji Maharaj Medical University, Lucknow, Uttar Pradesh, India. Case reports : 01 / 2012; 2012, DOI : 10.1136 / BCR – 2012 - 007077.
- [7] Unilateral facial palsy in Guillain Barre Syndrome (GBS): A rare occurrence, Verma R, Chaudhari TS, Giri P.

### AUTHORS

**First Author** – Dr. B. Suryanarayana, M.D., Asst Prof. of Medicine, Osmania General Hospital, Hyderabad, Telangana State, India.

**Second Author** – Dr. R. Siddeswari, M.D., Prof. of Medicine, Osmania General Hospital, Hyderabad, Telangana State, India.

**Third Author** – Dr. B. Sudarsi, M.D., Asst Prof. of Medicine, Osmania General Hospital, Hyderabad, Telangana State, India.

**Fourth Author** – Dr. S. Manohar, M.D., Professor & HOD of Medicine, Osmania General Hospital, Hyderabad, Telangana State, India.

**Fifth Author** – Dr. Pramod, (M.D.) PG, Osmania General Hospital, Hyderabad, Telangana State, India.



# Studies on Primary Productivity of Bay of Bengal at Chandrabhaga Sea-Shore, Konark, Odisha

Ashabari Sahoo and A.K.Patra

P.G. Department of Zoology, Utkal University, Vanivihar, Bhubaneswar, Orissa, India

**Abstract-** Primary production refers to estimation of the ability of an ecosystem to fabricate, at the expense of external energy both radiant and chemical, primary organic compounds of high chemical potentials for further transformation and flow to higher system levels. In the present investigation the light dark oxygen method was followed in order to assess the of primary productivity of Bay of Bengal at Chandravaga, Konark, Odisha, Seasonally, the maximum Gross Primary Production and Net Primary Production were recorded in summer due to clear weather and high atmospheric temperature and minimum during Monsoon season due to cloudy weather. On the other hand, Community respiration was found to be higher during summer season and lower during winter season.

**Index Terms-** Primary production, gross primary production, net primary production, Community Respiration, Bay of Bengal and Chandrabhaga.

## I. INTRODUCTION

Primary productivity is the route by which simple organic compounds are manufactured by living organisms from various inorganic forms of carbon available on earth such carbon dioxide (CO<sub>2</sub>), bicarbonate (HCO<sub>3</sub><sup>-</sup>), and carbonate (CO<sub>3</sub><sup>2-</sup>). These Inorganic oxidized forms of carbon are chemically reduced to form the organic molecules, which are the building blocks of life, and the mechanism by which energy is stored in living organisms and is utilized in driving cellular process(Daniel). The process of reduction of inorganic carbon is dependent on the light energy or from energy stored in some reduced inorganic compounds. Autotrophs are organisms capable of fixing inorganic carbon. Photoautotrophs use light energy to fix carbon, whereas chemoautotrophs use the energy released through the oxidation of reduced inorganic substrates to fix carbon into organic compounds. Both photosynthesis and chemosynthesis contribute to the primary production of the oceans, however oxygenic photosynthesis is by far the dominant process in terms of the amount of carbon fixed and energy stored in organic compounds. Generally, photosynthesis occurs in all parts of the ocean where there is sufficient light.

So briefly, it can be said that the primary productivity of a water body is the manipulation of its biological production (Mohanty *et al.*, 2014). It forms the basis of the ecosystem functioning (Odum, 1971). It plays an important role in energy and organic matters available to the entire biological community (Ahmed *et al.*, 2005). The estimation of primary productivity is predicted on the relationship between oxygen evolution and carbon fixation (Dash *et al.*, 2011). Primary productivity varies

from fresh-water to estuarine and from estuarine to marine water body (Dash *et al.*, 2011).

The present study deals with gross, net and community productivity of marginal seawater of Bay of Bengal at Chandrabhaga, Konark, Odisha.

## II. MATERIAL AND METHODS

The water samples were collected from 50 cm. depth from the sea-shore and analyzed for primary productivity. The study was conducted for the year that is 2013-14. Different techniques have been used by different workers viz. Radioactive Carbon (C<sup>14</sup>) (Slumann-Nielson, 1952), Chlorophyll method (Ryther and Yentsch, 1957) and oxygen method by light and dark bottle (Gaarder and Gran, 1927, Vollenweiden, 1969) for estimation of primary productivity. Among them, the light dark oxygen method is a simple and standard approach for measuring photosynthesis in aquatic systems and therefore the said method was adopted for analysis of primary productivity during the present investigation.

Water samples were collected in triplicates around the middle of every month (Mohanty *et al.*, 2014, Mohapatra *et al.* 2010). The sample in the first bottle was used immediately to determine the initial level of dissolved oxygen following Wrinklers Volumetric method (APHA, 2008). Dissolved oxygen values obtained were converted to carbon values by multiplying with the factor 0.375 (Odum, 1956, Mohapatra and Patra, 2012). The second bottle was painted with black color to prevent light penetration and hence served as a control to measure respiration. The third light bottle was treated as a test to measure the net production. The last two bottles were incubated under water in the euphotic zone for a period of twenty four hours at 50 cm. depth and then oxygen content was measured and then the DO. values were converted to gCm<sup>-2</sup> day<sup>-1</sup> multiplied by average water depth. Oxygen values mg l<sup>-1</sup> were converted to carbon values by applying the equation suggested by Thomas *et al.*, 1980 and Ahmed *et al.*, 2005.

Primary Production gC = mg l<sup>-1</sup> x 0.375/PQ

Where PQ = 1.25

PQ represents respiratory quotient = respiration/photosynthesis and a compromised value of 1.25 was used which represent metabolism of sugars, some fats and proteins.



### III. RESULTS AND DISCUSSION

The experimental data of Monthly and seasonal variations of gross primary productivity (GPP), net primary productivity (NPP) and community respiration (CR) along with mean standard deviation are shown in Table No.1 and Table No.2 respectively.

The community respiration (CR) exhibited a higher value during the June and lower value on December (Table no.1). On seasonal basis, the value was found to be maximum ( $91.16 \pm 5.94$ )  $\text{gCm}^{-2}\text{day}^{-1}$  during summer and minimum during winter ( $46.2 \pm 3.92$ )  $\text{gCm}^{-2}\text{day}^{-1}$  (Table No. 2) (fig.1). The decreased value during winter may have resulted due to low water temperature and reduced light (Ahmed and Singh, 1987 and Dash *et al.*, 2011).

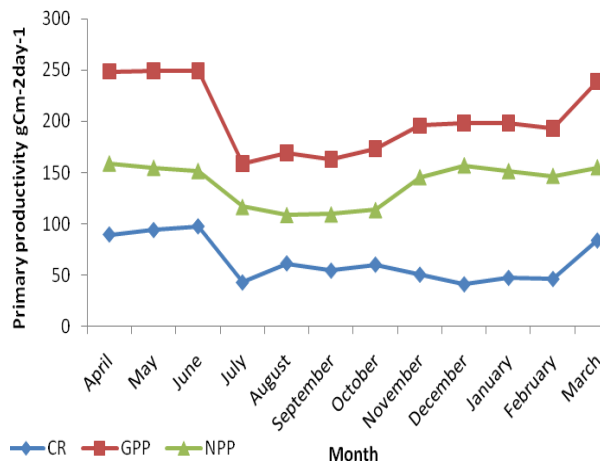
Seasonally, maximum GPP and NP value were documented during summer  $246.18 \pm 4.93$  and  $155.02 \pm 3.01$   $\text{g C m}^{-2} \text{day}^{-1}$  respectively likewise the minimum value of GPP ( $166.31 \pm 6.44$   $\text{g C m}^{-2} \text{day}^{-1}$ ) and NP ( $111.67 \pm 3.76$   $\text{g C m}^{-2} \text{day}^{-1}$ ) was recorded in monsoon season and an intermediate value in winter season (Table No.2 and fig.2). From this, it may be concluded that the weather condition has an significant effect on the productivity in aquatic ecosystem. This statement hold good as the higher values of net, gross primary productions were reported from October to June when weather condition was bright and clear and this allowed to better penetration of light into water body and facilitated the higher rate of planktonic photosynthesis and thus ultimately the productivity of the marine system (Madhupratap, 2001). Lower Production value during rainy season may be due to cloudy weather, organic affluent in water, low transparency and high water current (Hutchinson, 1957, Mohapatra *et al.* 2012).

The ratio of net and gross primary production is essential for the evaluation of the amount of gross production available to the consumers (Singh and Singh, 1999). In our study we noticed that the ratio between NPP : GPP as well as NPP : CR was highest (0.764, 3.274) during winter and lowest (0.629, 1.706) (Table No.2) during summer. The community respiration accounted 20 to 40% of GPP during all the months of year (Table No.1), which shows good index (Muraleedharan, 2001).

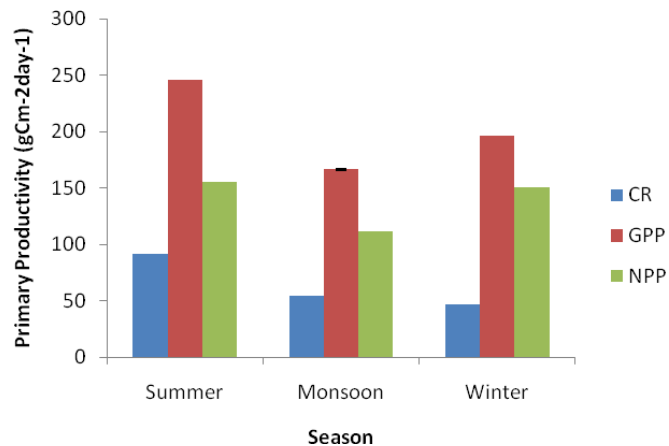
The NPP : CR value  $> 1$  (3.274) in winter which accounts for more penetration of light into water body as well as suitable temperature which favors abundance of planktons and more photosynthetic activities (Das, Patra and Adhikary, 2011, Mohanty *et al.*, 2014)

Higher production is not governed by a single factor as stated by Singh and Singh, (1999), Moharana and Patra (2013). There are several physicochemical and biological factors, which in fact manage the rate of production in marine ecosystem (Mohanty *et al.*, 2000). Hence, it comes into view that there is a

direct correlation between temperature and production, which is in agreement with Srinivasan (1964), Hall & Moll (1975), Goldman and Wetzel (1963), Mohanty *et al.*, 2000, Pauly & Christensen (1995) and Thomas *et al.*, 1980. In the present study the same observation was noticed that is the productivity is high at high temperature, while in winter as the temperature is low the productivity is also low.



**Figure 1: Monthly variations in Primary Productivity (GPP, NPP and CR) of Chandrabhaga-on-Sea during 2013-2014 in ( $\text{gC m}^{-2} \text{day}^{-1}$ ).**



**Figure 2: Seasonal variations in Primary Productivity (GPP, NPP and CR) of Chandrabhaga-on-Sea during 2013-2014 in ( $\text{gCm}^{-2} \text{day}^{-1}$ ).**

#### ACKNOWLEDGMENT

Authors are thankful to the Head of the Department of Zoology and Pharmacy, Utkal University for providing necessary laboratory facilities.

#### REFERENCES

- [1] Ahmed K.K.U, Ahmed S.V., Halder G.C., Hossain M.R.A. and Ahmed T.S., 2005. Primary production and fish yield estimation in the Meghna river system, Bangladesh. *Asian Fisheries Science*, 18 : 95 – 105.
- [2] APHA, 2008. American Water Works Association and Water Pollution Control Federation standard methods for examination of water and waste water. A.M. Pub. Health Association, New York, USA.
- [3] Dash S, Patra A.K. and Adhikary S., 2011. Primary Productivity of Kharasota River (India). *J. Ecophysiol. OCCUP. Hlth*, 11: 219-225.

- [4] Daniel Conrad Ogilvie Thornton (2012). Primary Production in the Ocean, Advances in Photosynthesis - Fundamental Aspects, Dr Mohammad Najafpour (Ed.), ISBN: 978-953-307-928-8, InTech.
- [5] Hall. C. and Moll. R., 1975 methods of assessing aquatic primary production in Primary production of the Biosphere (eds. H. Lieth and R. Whittaker). Springer Verlag, New York, PP 19-53.
- [6] Gaarader and Gran (1927) : Production of plankton in the OSIO F. Jord-Rapp. proc. Veb. cons perm Int. explore. nev, 42:1-48.
- [7] Madhupratap M., M. Gauns, N. Ramaiah, S. Prasanna Kumar, P.M. Muraleedharan, S. N. De Souza, S. Sardesai an Usha Muraleedharan, , Biogeochemistry of the Bay of Bengal: Physical, Chemical and primary productivity characteristics of the central and western Bay of Bengal during summer monsoon, 2001.
- [8] Mohanty R.K., 2000, Primary production and seasonal plankton abundance in artificially controlled semiintensive shrimp pond. J. Indian Sco. Coastal Agric. Res 18 (i) : 40 – 46.
- [9] Mohanty SS, Pramanik D.S., Dash B.P. (2014) Primary Productivity of Bay of Bengal at Chandipur in Odisha,India .International Journal of Scientific and Research Publications, 4(10) ,1-6.
- [10] Mohapatra S. and Patra A.K., 2012. Studies on Primary productivity of Bay of Bengal at Puri Sea-shorein Orissa, IJSRP, Vol-2, Issue 10.
- [11] Moharana P. and Patra A.K., 2013 Primary productivity of Bay of Bengal at Digha in west Bengal, India. JLSci 3(i)129-132.
- [12] Odum E.P., 1971 Fundamentals of Ecology, 3rd edn. W.B. Saunders Company, Philadelphia, 574.
- [13] Singh A.K. and Singh D.K. 1999, A Comparative study of the Phytoplanktonic primary production of river Ganga and Pond of Patna (Bihar). India J. Environ. Biol, 20 : 263 – 270.
- [14] Sreenivasan, A. (1963) Primary production in three upland lakes of Madras state. Current Science, 32, 130-131.
- [15] Thomas P.A., Abraham. T . and Abraham K.G., 1980. Observation on the primary productivity of Sasthamkotta lake : Dn. Alexender, K.M. etal (eds) Proc. Symp. Environ. Biol. Trivandram : 1 – 7.
- [16] Volleweiden R.A., 1969. A manual on methods for measuring production in the aquatic environment IBP, Hand Book No. 12, Black well scientific Publications, Oxford, England. 138 : 465 -482.

#### AUTHORS

**First Author** – Author name, qualifications, associated institute (if any) and email address.

**Second Author** – Author name, qualifications, associated institute (if any) and email address.

**Third Author** – Author name, qualifications, associated institute (if any) and email address.

**Correspondence Author** – Author name, email address, alternate email address (if any), contact number.

**Table1: Mean Monthly Variations of GPP, NPP and RES Values in  $gC\ m^{-2}\ day^{-1}$  (Mean  $\pm$  S.D.) At Chandrabhaga During The Year 2013-2014 (n = 3).**

Month	RES(CR) ( $gCm^{-2}day^{-1}$ )	GPP ( $gCm^{-2}day^{-1}$ )	NPP ( $gCm^{-2}day^{-1}$ )	NPP/GPP	NPP/CR	CR % of GPP
April	89.55	248.4	158.85	0.639	1.77	36.05
May	93.9	248.55	154.65	0.622	1.64	37.77
June	97.5	249	151.5	0.608	1.55	39.15
July	42.75	159	116.25	0.731	2.71	26.88
August	61.35	169.65	108.3	0.638	1.76	36.16
September	54.3	163.2	108.9	0.667	2.005	33.27
October	60.15	173.4	113.25	0.653	1.88	34.68
November	50.4	195.75	145.35	0.742	2.88	25.74
December	40.95	198	157.05	0.793	3.83	20.68
January	47.25	198.6	151.35	0.762	3.20	23.79
February	46.2	192.9	146.7	0.760	3.17	23.95
March	83.7	238.8	155.1	0.649	1.85	35.05

**Table2: Mean Seasonal Variations of GPP, NPP and RES Values in (mean  $\pm$  SD) in  $g\ C\ m^{-2}\ day^{-1}$  at Chandrabhaga during The Year 2013-2014.**

Season	RES(CR) ( $gCm^{-2}day^{-1}$ )	GPP ( $gCm^{-2}day^{-1}$ )	NP ( $gCm^{-2}day^{-1}$ )	NPP/GPP	NPP/CR
	Mean $\pm$ SD	Mean $\pm$ SD	Mean $\pm$ SD	Mean	Mean
Summer	91.16 $\pm$ 5.94	246.18 $\pm$ 4.93	155.02 $\pm$ 3.01	0.629	1.706
Rainy	54.63 $\pm$ 8.50	166.31 $\pm$ 6.44	111.67 $\pm$ 3.76	0.672	2.093
Winter	46.2 $\pm$ 3.92	196.312 $\pm$ 2.58	150.98 $\pm$ 5.29	0.764	3.274

# Response of Pechay (*Brassica napus* L.) to Different Levels of Compost Fertilizer

Leif Marvin R. Gonzales\*, Ramonita A. Caralde\*\* and Maita L. Aban\*\*\*

\*Capiz State University – Pontevedra Campus, Bailan, Pontevedra, Capiz, Philippines

\*\* Capiz State University – Burias Campus, Mambusao, Capiz, Philippines

\*\*\*Visayas State University, Visca, Baybay City, Leyte, Philippines

**Abstract-** Organic fertilizer is a good source of nutrients for the soil. It improves the soil's physical, chemical and biological characteristics. This study was conducted to evaluate the growth and yield performance of pechay applied with different levels of compost as organic fertilizer and determines the effect of organic fertilizer in terms of plant height, number of leaves per plant, fresh weight per plant and leaf area. The pot experiment was laid out in randomized complete block design (RCBD) with five treatments and replicated three times. Significant differences between treatments means were determined using the Duncan Multiple Range Test (DMRT). The analysis of variance (ANOVA) showed, that there were no significant differences in the plant height and number of leaves. However, leaf area of pechay was significantly affected by application of T3 = 50% pure garden soil: 50% pure compost (OF) in combination and in terms of yield, the fresh weight of pechay was significantly increased with the application of T4 = 75% pure garden soil: 25% pure compost (OF). Application of 50% pure garden soil: 50% pure compost (OF) and 75% pure garden soil: 25% pure compost (OF) significantly affected the leaf area and fresh weight of pechay. This implies that compost application greatly increased or influenced the growth and development of the pechay plant.

**Index Terms-** compost, goat manure, organic fertilizer, pechay (*Brassica napus* L.)

## I. INTRODUCTION

The agriculture sector is deemed unsustainable by various studies as the main focus of the current development agenda is feeding the ever-expanding population. It loses sight of the negative environmental consequences it creates, particularly on soil health. Land use is optimized through technologies and management practices that fall short of requirements for sustainability. The current practice in agriculture is basically chemical-based farming that makes a considerable contribution to the degradation of our natural resources especially soils. Heavy application of fertilizers has polluted surface and groundwater resources (dela Cruz, 2006).

Growing vegetables has been a practice for centuries in civilized countries. Vegetables are a very important food commodity. Aside from playing a major role in meeting our vitamin, mineral and protein requirements, they also serve as a reliable source of income of farmers (Chauburg, 1984 as cited by Torrefiel, 2006). The income derived from growing vegetables is

relatively higher than other crops, because growers can produce more crops from a small area in a very short period of time.

Pechay (*Brassica napus* L.) belongs to the Brassicaceae family and one of the most known vegetables in the Philippines. It is also known as one of the oldest green vegetables in Asia. It therefore plays an important role in the Philippine economy as well as in the nutrition of the Filipino people. Pechay is used mainly for its immature, but fully expanded tender leaves. The succulent petioles are often the preferred part. It is used as main ingredient for soup and stir-fried dishes. In Chinese cuisine, its green petioles and leaves are also used as garnish (<http://www.darfu4b.da.gov.ph/pechay.html>).

Fertilizer application using either inorganic or organic fertilizer sources is one of the most common cultural management practices in vegetable production. According to Lampkin (1990) as cited by Masarirambi, (2010) that the commercial and subsistence farming has been and is still relying on the use of inorganic fertilizers for growing crops. This is because they are easy to use, quickly absorbed and utilized by crops. However, these fertilizers are believed to contribute substantially to human, animal food intoxication and environmental instability or degradation (Masarirambi, 2010).

Inorganic fertilizers are the most common fertilizers used by the farmers. However, its use incurs a high cost and its supply is sometimes limited that many farmers now are still adapting the idea of using organic fertilizers no matter how long and laborious is the preparation. Brady (1974) reported that organic matter increases the cation exchange capacity of the soil. Aside from its ability to supply nutrients, organic fertilizers are also capable of improving the physical, chemical and biological properties of the soil which could significantly improve the growth and development of plants.

Among the potential sources of organic fertilizers is compost. Composts are a form of organic fertilizer; they are considered low-analysis fertilizers because they contain about 1% N and P and their organic nitrogen mineralization rate is about 10% (Sikora and Enkiri, 2001 as cited by Espiritu, 2011). Organic fertilizer has been defined as any product of plant and/or animal origin that has undergone.

There is increased demand of organically produced vegetables in view of its health and nutritional benefits. There is paucity of information on the use of organic fertilizers for vegetable production and therefore this study aimed to evaluate the effect of different levels of compost as a source of organic fertilizers on the growth and yield performance of pechay.

## II. METHODOLOGY

### A. Procurement of Different Sources of Organic Materials

Goat manure was secured from the Goat and Sheep Project of the Department of Animal Science of Visayas State University, Visca, Baybay City, Leyte. Rice straw and carbonized rice hull ash was procured from the Rice Project of the Department of Agronomy and Soil Science. These organic materials were processed to allow decomposition for easy release of nutrients.

### B. Composting Process

Three piles were prepared using different raw materials from several origins. This includes, 4 sacks goat manure, 2 sacks rice straw and 1 sack carbonized rice hull ash. The entire pile was covered with plastic sheet completely in a shade to maintain the heat of decomposition and minimizes water evaporation and ammonia volatilization. Twice a week the organic materials were mixed thoroughly to prevent overheating and aerate the pile for faster decomposition process. Watering was done regularly to add moisture content in the composting materials. The compost was harvested after 2 months of decomposition.

### C. Seedling Production

Seeds of pechay were sown in seedling trays filled with garden soil and compost at 1:1 ratio. The seed boxes were placed under structure to protect the seedlings from rain and direct sunlight. The seedlings were hardened by gradual exposure to sunlight and withdrawal of water until they showed signs of temporary wilting.

### D. Transplanting

The seedlings were transplanted into the pots 7 days after germination. One seedling was planted per pot. The media was filled to  $\frac{3}{4}$  of the volume of the plastic pot. Transplanting of seedling was done late in afternoon to minimize transplanting stress. The seedlings were watered adequately before and immediately after transplanting.

### E. Experimental Design and Treatment

Seventy-five polyethylene pots were used in the study with a size of 20 cm. The pot experiment was laid out in Randomized Complete Block Design (RCBD) with five treatments and replicated three times. There were five sample plants per replication. The treatments were as follows:

- T1 = Pure Garden Soil (control)
- T2 = Pure Compost (OF)
- T3 = 50% Pure Garden Soil: 50% Pure Compost (OF)
- T4 = 75% Pure Garden Soil: 25% Pure Compost (OF)
- T5 = 85% Pure Garden Soil: 15% Pure Compost (OF)

### F. Harvesting

Pechay plants were harvested at 21 days after transplanting and were done early in the morning to minimize weight loss. This was done by cutting the base of the plants with a sharp knife to avoid damage of the plants.

### G. Data Analysis

Data were analyzed using the analysis of variance (ANOVA) and significant differences between treatments means were determined by Duncan Multiple Range Test (DMRT) using the Statistical Package for Social Sciences (SPSS) ver. 15 and Statistic 6.

## III. RESULTS AND DISCUSSIONS

### *General Observations*

Three weeks after composting, the height of the pile has fallen to about 70 cm. A week later, rice straw and rice hull ash was totally decomposed but goat manure was not yet decomposed. The heat was still high one month after composting. This coincide with the report of Pace (1995) that the temperature of the composting materials generally follows a pattern of rapid increase to 120-140 °F where it was maintained for several weeks depending on the materials.

The decomposition was attained two months after composting considering that there was enough moisture that support the metabolic processes of the microbes. It was reported by Pace (1995) that composting materials should be maintained within a range of 40% to 65% moisture. He showed that the composting process becomes inhibited when the moisture content is below 40% and water displaces much of the air in the pore spaces of the composting materials when the moisture content is above 65%. This limits air movement and leads to anaerobic conditions.

Reduction of the volume of the pile was observed and the organic materials used were changed color to dark brown. The temperature drops and little heat is produced. The compost was then successful and was ready to use as an organic fertilizer source.

### *Horticultural Characteristics*

The result showed that T4 obtained the highest plant height, number of leaves/ plant and leaf area (Table 1). On the other hand, it was noted that T1 got the lowest growth performance.

Analysis of variance of leaf area resulted to highly significant differences between treatments means. All treatments that were applied with compost did not differ with each other but showed significant difference compared to control. However, a non-significant statistical result was found out on the plant height and number of leaves of pechay plant as affected by application of different levels of compost application. Although most plant nutrients in compost are in organic form, it only contains 2% each of nitrogen, phosphorous or potassium and these nutrients are released slowly over a long period of time. Nutrients become available to plant roots at a slower rate with compost, therefore the nutrients are less likely to leach out of the soil. Only a fraction of the nitrogen, phosphorus and potassium applied as compost is usable by the crop the first year with more becoming available in the years that follow (Pace, 1995). According to the studies by Rao (1991) showed that the soil could be enriched by application of higher amounts of organic materials which tends to decompose large amounts of nitrogen into the soil before planting each fresh crop to boost yield.



Treatments	Mean Plant Height (cm)	Number of leaves/plant	Leaf Area
T1 = Pure Garden Soil (control)	25.57	5.17	21.81b
T2 = Pure Compost (OF)	30.77	5.67	40.69a
T3 = 50% Pure Garden Soil: 50% Pure Compost (OF)	29.1	5.17	42.6a
T4 = 75% Pure Garden Soil: 25% Pure Compost (OF)	32.5	5.83	42.17a
T5 = 85% Pure Garden Soil: 15% Pure Compost (OF)	31.7	5.33	39.97a
<i>p-value</i>	0.1414ns	0.1865ns	0.0062**

ns= not significant

\*\*= highly significant

Note: Treatment means within the same column having common letters (s) designations are not significantly different from each other at 5 % level of significance, DMRT

#### Yield Performance

The data on the fresh weight of pechay as affected by different level of compost as fertilizer showed that T4 obtained the highest mean of 29.9, it was followed by T2, T3, T5 and T1 having the lowest fresh weight with the mean of 26.6, 23.5, 23.17 and 12.93 respectively as shown in Table 2.

Analysis of variance showed that there was highly significant difference between treatments means. This implies that fresh weight of pechay was greatly influenced by the application of different levels of compost. It was noted that this study used of goat manure as raw material for compost. According to the study of Awodun et al. (2007) that, the goat manure was quite high in OM and had more N than K, Ca and Mg. The low OM and available P and acidic nature of soils were expected to benefit from application of goat manure.

Table 2. Fresh weight of pechay as applied with different levels of compost fertilizers.

Treatments	Mean Fresh weight/plant (g)
T1 = Pure Garden Soil (control)	12.93b
T2 = Pure Compost (OF)	26.6a
T3 = 50% Pure Garden Soil:50% Pure Compost (OF)	23.5a
T4 = 75% Pure Garden Soil:25% Pure Compost (OF)	29.9a
T5 = 85% Pure Garden Soil: 15% Pure Compost (OF)	23.17a
<i>p-value</i>	0.0074**

\*\*= highly significant

Note: Treatment means within the same column having common letters (s) designations are not significantly different from each other at 5 % level of significance, DMRT

The higher increase in yield parameter such as fresh weight of pechay could be attributed to the nutrient contents of the organic fertilizers used which encouraged better seedlings growth. This observation agreed with the report of Adebayo and Akoun (2000) and Moyin-Jesu (2007) stated that organic manures supported crop growth performance and increased crop yield. In the study of Xu et al. (2005) revealed that the yield and quality of leafy vegetables grown with organic fertilizers grew better and resulted in a higher total yield than those grown with chemical fertilizers.

#### H. CONCLUSION

Based on the above results, it can be concluded that the application of T4 (75% Pure Garden Soil: 25% Pure Compost (OF)) provided the best growth and yield performance of pechay in terms of leaf area and fresh weight. None among the treatments used gave the better growth in terms of producing more leaves and height of the plant. The result of this study showed that application of organic fertilizer greatly enhanced growth and yield performance of pechay. The application of organic fertilizer in pechay specifically, compost is recommended since it influences its growth and yield, especially on the leaf area and fresh weight.

#### REFERENCES

- [1] Adebayo, O. and J. Akoun Effect of organic manures and spacing on the yield of *Amaranthus cruentus*, 20th Annual Conf. Proceedings of Horticultural Society of Nigeria. Umeh V.C. and Fagbayide .A. (eds.) 2000); 63-67.
- [2] Awodun M.A., Omonijo L.I. and Ojeniyi S.O., 2007. Effect of Goat Dung and NPK Fertilizer on Soil and Leaf Nutrient Content, Growth and Yield of Pepper. *International Journal of Soil Science*, 2: 142-147.
- [3] Brady, N.C. 1974. The nature and properties of soil. 8<sup>th</sup> edition. McMillan Pub. Co. Inc. New York. P680.
- [4] dela Cruz, N.E., Aganon C.P., Patricio M.G., Romero E.S., Lindain S.A. and. Galindez, J.L, 2006. Production of organic fertilizer from solid waste and its utilization in intensive organic-based vegetable production and for sustaining soil health and productivity. pp. 16 – 20
- [5] Espiritu, B.M, 2011. Interaction of Microbial Inoculants and Low-Chemical Fertilizer Rates in Enhancing the Quality of Sugarcane Mudpress-Chicken Manure Compost. *Philipp Agric Scientist*. (94)2:179-186
- [6] Moyin-Jesu, E. I. 2007. Effects of some organic fertilizers on soil and coffee (*Coffea arabica* L), leaf chemical composition and growth. *University of Khartoum Journal of Agricultural Science*; 15(1): 52-70.
- [7] Masarirambi, M.T.; Hlawe, M.M.; Oseni, O.T.; and Sibiya, T.E, 2010. Effects of organic fertilizers on growth, yield, quality and sensory evaluation of red lettuce (*Lactuca sativa* L.) 'Veneza Roxa' . *Agriculture and Biology Journal of North America*. 2151-7517.
- [8] Pace, M.G. 1995. The Composting Process. Utah State University. Department of Agriculture.
- [9] Rao, M.K., 1991. Textbook of Horticulture. University of Madaras. Madaras, India.
- [10] Torrefiel, D.B. Jr. 2006. Growth and yield performance of pechay (*Brassica napus* L.) as influenced by biogas digester effluent and rice hull ash application. Undergrad. Thesis. Visca,Baybay. Leyte.
- [11] Xu, H.L., Wang, R., Xu, R.Y., Mridha, M.A.U. and Goyal, S., (2005). Yield and quality of leafy vegetables grown with organic fertilizations. *Acta Hort.*, 627: 25-33
- [12] <http://www.darfu4b.da.gov.ph/pechay.html>.

AUTHORS

**First Author** – Leif Marvin R. Gonzales, MS in Horticulture,  
Capiz State University – Pontevedra Campus, Capiz, Philippines  
Email address: [gleifmarvin@yahoo.com](mailto:gleifmarvin@yahoo.com)

**Second Author** – Ramonita A. Caralde, MS in Horticulture,  
Capiz State University – Burias Campus, Capiz, Philippines

**Third Author** – Maita L. Aban, PhD in Animal Science,  
Visayas State University, Leyte, Philippines.  
Email address: [maita\\_aban@yahoo.com](mailto:maita_aban@yahoo.com).

**Correspondence Author** – Leif Marvin R. Gonzales  
Email address: [gleifmarvin@yahoo.com](mailto:gleifmarvin@yahoo.com)  
Contact number: +639358183282

# Spectral studies on transition metal complexes with novel tridentate aroylhydrazones

Kamalika Banerjee\*, Pramod Kumar Singh\*\*, Sangeeta Singla\*\*\*

\*Dr.Kamalika Banerjee Associate Professor, School of Sciences, Chemistry, IGNOU, Maidan Garhi, Delhi-110068, India,

\*\*Dr.Pramod Kumar Singh Associate Professor, Department of Chemistry, Kirorimal College, University of Delhi, Delhi-110007, India,

\*\*\*Sangeeta Singla Associate Professor, Department of applied Science and Humanities, Dronacharya College of Engineering, Gurgaon- 122001, Haryana, India

**Abstract-** Coordination complexes of Chromium(III), Manganese(II), Iron(III) and Zinc(II) with two new novel ligands N-2-hydroxybenzaldehyde- N'-isonicotinoylhydrazones ( $\text{hbihH}_2=\text{H}_2\text{L}^1$ ) and N-2-hydroxy-4-methylbenzaldehyde- N'-isonicotinoylhydrazone ( $\text{hmihH}_2= \text{H}_2\text{L}^2$ ) have been prepared and characterized by elemental analysis, electrical conductance, IR spectra,  $^1\text{H}$  NMR spectra, EPR spectra, Magnetic susceptibility, and TGA analysis. Aroylhydrazones act as dibasic tridentate ligand in the chelates, coordinating through the deprotonated naphtholic oxygen atom, azomethine nitrogen atom and enolic oxygen atom, based on the nature of metal salts used and the reactions conditions. The magnetic and spectral data indicates the chelates to be in octahedral environment and analytical data indicate 1:1 stoichiometries for all the complexes.

**Index Terms-** Aroyl hydrazones, isonicotinoyl hydrazone, ketonic oxygen, metal complexes.

## I. INTRODUCTION

The coordination chemistry of aroylhydrazones has been widely invested due to its remarkable biological properties and interesting bonding pattern with metal ions [1-9]. This paper describes the synthesis and characterization of Cr(III), Mn(II), Fe(III), and Zn(II) complexes of two new aroylhydrazone ligands as shown in Figure-1(a &b).

## II. EXPERIMENTAL

All the chemical and metal salts used in this synthesis were of reagent grade and used without further purification. The solvents were dried before use by conventional method.

### 2.1. Preparation of ligand

The ligand  $\text{H}_2\text{L}^1$  was obtained by condensation of ethanolic solution of isonicotinoyl hydrazine (0.05 mol) with ethanolic solution of 2-hydroxybenzaldehyde (0.05 mol) with constant stirring. The resulting mixture was heated under reflux for 3 h and cooled at room temperature. The white precipitate was separated by filtration, washed with ethanol and dried in vacuum.

The ligand  $\text{H}_2\text{L}^2$  was prepared as white precipitate by following similar procedure by condensation of ethanolic solution of isonicotinoyl hydrazine (0.05 mol) with ethanolic solution of 2-hydroxy-4-methylbenzaldehyde (0.05 mol). The ligand  $\text{H}_2\text{L}^1$  and  $\text{H}_2\text{L}^2$  has the general structure:

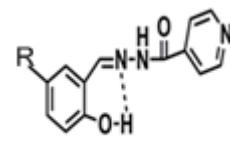


Figure – 1(a &b): Structure of ligands

- (a)N-2-hydroxybenzaldehyde-N'-isonicotinoylhydrazone ( $\text{R}=\text{H}$ ), ( $\text{hbihH}_2=\text{H}_2\text{L}^1$ )  
(b)N-2-hydroxy-4-methylbenzaldehyde-N'-isonicotinoyl hydrazone ( $\text{R}=\text{CH}_3$ ), ( $\text{hmihH}_2= \text{H}_2\text{L}^2$ )

## 2.2 Synthesis of complex

The Cr(III) complexes were obtained by refluxing an ethanolic solution of  $\text{CrCl}_3 \cdot 6\text{H}_2\text{O}$  and Hydrazine ligand ( $\text{H}_2\text{L}^1$  and  $\text{H}_2\text{L}^2$ ) in 1:1 mol ratio for 2 h with stirring. The resulting precipitate, after cooling to room temperature was separated by filtration, washed with ethanol and dried in vacuum over anhydrous  $\text{CaCl}_2$  and purity was checked by TLC and elemental analysis.

The Mn(II), and Zn(II), complexes were prepared by adding the solution of  $\text{M}(\text{OAc})_2 \cdot n\text{H}_2\text{O}$  (1.0 mmol) [ $\text{M}=\text{Mn}(\text{II})$ , and  $\text{Zn}(\text{II})$ ] in anhydrous ethanol (10 $\text{cm}^3$ ) drop wise, with stirring to the solution of Hydrazine ligand ( $\text{H}_2\text{L}^1$  and  $\text{H}_2\text{L}^2$ ) (1.0 mmol) in anhydrous ethanol (20 $\text{cm}^3$ ).The reaction mixture was refluxed for 2 h, cooled, filtered, washed with ethanol and dried in vacuum.

The Fe(III) complexes were obtained by refluxing the ethanolic solution of  $\text{FeCl}_3$  (anhydrous) and hydrazine ligand ( $\text{H}_2\text{L}^1$  and  $\text{H}_2\text{L}^2$ ) in 1:1 mol ratio for 3 h with stirring. The resulting precipitate was cooled, filtered, washed with ethanol and dried in vacuum.

## III. ELEMENTAL ANALYSIS AND PHYSICAL MEASUREMENT

C, H and N were determined micro analytically and metal contents were estimated using Perkin-Elmer 2380 atomic absorption spectrophotometer. The chloride was analyzed by standard method [12]. IR spectra were recorded on Perkin -Elmer FT-IR spectrophotometer as KBr discs in the 4000-200 $\text{cm}^{-1}$  region. Electronic spectra were recorded in DMF on Beckman

DU-2 spectrophotometer. <sup>1</sup>H NMR spectra were recorded on Varian FT-80A NMR spectrophotometer using DMSO-d<sub>6</sub> as solvent and TMS as internal standard. Magnetic measurements were carried out at room temperature using Gouy's method employing Hg[Co(SCN)<sub>4</sub>] for calibration purpose and were corrected for diamagnetism by using Pascal's constants. Molar conductance was measured in DMF (10<sup>-3</sup>M) with digital conductivity model 304 X-band. EPR spectra were recorded on JEOL JES-3XG ESR spectrometer. Thermal behavior was monitored on 8150 thermo analyzer at the heating rate of 10°C/min<sup>-1</sup>.

#### IV. RESULT AND DISCUSSION

All the complexes were air-stable, non hygroscopic, decomposes at higher temperature, insoluble in common organic solvents but soluble in strong polar solvents, such as DMF and DMSO. The stoichiometries of the complexes have been deduced

from elemental analysis result, (Table -1) which indicate that the ligand co-ordinate to the metal ion in 1:1 molar ratio. The melting points of the complexes are higher than that of the ligand revealing that the complexes are much more stable than the ligands. The molecular weights of the complexes could not be obtained by cryoscopy due to insolubility of the complexes in benzene/nitrobenzene.

The molar conductance value of the complexes lies in the range of 15.7 to 27.8 Ω<sup>-1</sup> mol<sup>-1</sup>cm<sup>2</sup> (at 15°C) indicating non electrolytic nature of the complexes[13], while the molar conductance of chloride complexes of Cr(III), and Fe(III) lies in the range of 80-84 Ω<sup>-1</sup> mol<sup>-1</sup>cm<sup>2</sup> attributed to 1:1 electrolyte, which indicate that the chloride ion is not affected by DMF and still present in the coordination sphere to balance the charge only as counter ions but not in coordination.

**Table -1: Analytical data and molar conductance for the complexes**

Compound	Decomposition Temperature (°C)	Color	Yield (%)	Found( Calculated) %				Molar conductance <sup>a</sup> (Ω <sup>-1</sup> cm <sup>2</sup> mol)
				C	H	N	M	
[H <sub>2</sub> L <sup>1</sup> ] (C <sub>13</sub> H <sub>11</sub> N <sub>3</sub> O <sub>2</sub> )	170-176	White	76	63.80 (64.73)	4.59 (4.56)	17.10 (17.42)	-	-
[MnL <sup>1</sup> ].2H <sub>2</sub> O	>252	Brown	79	46.79 (47.28)	3.10 (3.94)	12.12 (12.73)	16.25 (16.65)	22.70
[CrL <sup>1</sup> Cl].H <sub>2</sub> O	>242	Rust	81	44.90 (45.29)	2.92 (3.19)	11.80 (12.20)	14.59 (15.09)	26.90
[FeL <sup>1</sup> Cl].H <sub>2</sub> O	>262	Black	77	44.00 (44.91)	2.87 (3.16)	11.67 (12.09)	15.07 (15.79)	82.00
[ZnL <sup>1</sup> ].2H <sub>2</sub> O	>270	Orange	79	45.10 (45.82)	3.09 (3.81)	11.89 (10.33)	18.76 (19.21)	73.00
[H <sub>2</sub> L <sup>2</sup> ] (C <sub>14</sub> H <sub>11</sub> N <sub>3</sub> O <sub>2</sub> )	185-191	White	75	64.92 (65.88)	4.82 (5.09)	-	-	-
[MnL <sup>2</sup> ].2H <sub>2</sub> O	245	Deep brown	76	47.92 (48.84)	3.94 (4.36)	11.87 (12.21)	15.09 (15.97)	21.89
[CrL <sup>2</sup> Cl].H <sub>2</sub> O	250	Black	81	46.05 (46.86)	3.19 (3.62)	11.20 (11.71)	14.07 (14.50)	81.72

[FeL <sup>2</sup> Cl].H <sub>2</sub> O	240	Black Green	79	46.09 (46.49)	3.10 (3.59)	11.06 (11.62)	14.82 (15.18)	76.00
[ZnL <sup>2</sup> ].2H <sub>2</sub> O	280	Orange	84	46.98 (47.40)	3.87 (4.23)	11.12 (11.85)	17.96 (18.45)	23.54

a= measure in 10<sup>-3</sup>m DMF solution at room temperature.

#### 4.1 Infrared spectra

The distinctive IR band (Table-2) of the complexes differed from the free ligands (H<sub>2</sub>L<sup>1</sup> and H<sub>2</sub>L<sup>2</sup>) which provide significant indications regarding coordination and bonding sites of the ligand. Hydrazones can exist in the keto or enol tautomeric form in the solid state. The IR spectra of the ligand shows characteristic absorption band at 3500-3530, 3156-3290, 1640-1665, 1540-1590, 1480-1530, and 950-1030 cm<sup>-1</sup> due to  $\nu(\text{O-H})$  and  $\nu(\text{N-H})$ ,  $\nu(\text{C=O})$ ,  $\nu(\text{C=N})$ ,  $\delta(\text{N-H})$  and  $\nu(\text{N-N})$ , respectively. Absorption band at 1640-1665 cm<sup>-1</sup> confirms that the compound is in the keto form in solid state. The IR spectra of the compound reveal remarkable difference compared to these of the ligand. The  $\nu(\text{O-H})$  band at 3500-3530 cm<sup>-1</sup> for the ligand disappear in the complex, suggesting co-ordination through deprotonated phenolic oxygen. The absorption band attributed to  $\nu(\text{N-H})$ ,  $\nu(\text{C=O})$ , and  $\delta(\text{N-H})$  disappeared in complex and two new bands due to conjugate system  $\nu(\text{=C-N-N-C=})$  and  $\nu(\text{C-O}^-)$ , appeared in the region 1615-1640 and 1325-1350 cm<sup>-1</sup>, respectively [10]. The band for  $\nu(\text{C=N})$  undergoes a bathochromic shift of 15-25 cm<sup>-1</sup> in (H<sub>2</sub>L<sup>1</sup>) and 50-60 cm<sup>-1</sup> in (H<sub>2</sub>L<sup>2</sup>) and  $\nu(\text{N-N})$  band shows hypsochromic shift of 35-45 cm<sup>-1</sup> in (H<sub>2</sub>L<sup>1</sup>) and 40-60 in (H<sub>2</sub>L<sup>2</sup>), indicating that the metal ion form neutral coordination compound with the ligand in enol form through azomethine nitrogen and

amide oxygen negative ion [14]. A shift of  $\nu(\text{C=N})$  band to a lower frequency is due to the conjugation of the p-orbital on the double bond with reduction of d-orbital on the metal ion with reduction of force constant. A shift of  $\nu(\text{N-N})$  band to higher frequency is attributed to the electron attracting inductive effect when forming the conjugated system [10].

The coordination of azomethine nitrogen with metal ion is further supported by the presence of new bands in the far IR region 340-370 cm<sup>-1</sup> assignable to  $\nu(\text{M-N})$  for complex [11]. The characteristic absorption band at 1565-1590 cm<sup>-1</sup> and 725-750 cm<sup>-1</sup> respectively, are assignable to  $\nu(\text{C-C})$  and  $\nu(\text{C-H})$  of the benzene ring ligand and complexes. The pyridine ring stretching, in plane ring deformation and out of plane ring deformation vibrations are found at 1480 cm<sup>-1</sup>, 610 cm<sup>-1</sup> and 505 cm<sup>-1</sup> respectively in the ligands and remain unaffected in the complexes. The new absorption band at 3290-3390 cm<sup>-1</sup> in Cr(III), Mn(II), Fe(II) and Zn(II) complexes are assignable to stretching vibrations of the crystal water involved in two complexes. In the far IR region two new bands around 420-450 cm<sup>-1</sup> and 300-340 cm<sup>-1</sup> in complex can be assigned to  $\nu(\text{M-O})$  and  $\nu(\text{M-N})$  respectively.

**Table-2: IR Spectra**

Complexes	$\nu$ (OH)	$\nu$ (N-H)	$\nu$ (C=O)	$\nu$ (C=N)	$\delta$ (N-H)	$\nu$ (N-N)	$\nu$ (C-H) + $\delta$ (N-H)	$\nu$ (N-H) + $\delta$ (C-O)	$\nu$ (M-O)	$\nu$ (M-N)
[H <sub>2</sub> L <sup>1</sup> ] (C <sub>13</sub> H <sub>11</sub> N <sub>3</sub> O <sub>2</sub> )	3505	3155	1640	1540	1480	950	-	-	435	-
[MnL <sup>1</sup> ].2H <sub>2</sub> O	3295 <sup>a</sup>	-	-	1530	-	990	1640	1340	436	310
[CrL <sup>1</sup> Cl].H <sub>2</sub> O	3280 <sup>a</sup>	-	-	1525	-	995	1635	1345	440	320
[FeL <sup>1</sup> Cl].H <sub>2</sub> O	3370 <sup>a</sup>	-	-	1535	-	1000	1630	1335	448	330
[ZnL <sup>1</sup> ].2H <sub>2</sub> O	3390	-	-	1550	-	970	1625	1345	420	335
[H <sub>2</sub> L <sup>2</sup> ] (C <sub>14</sub> H <sub>11</sub> N <sub>3</sub> O <sub>2</sub> )	3530 <sup>a</sup>	3290	1665	1590	1530	965	1620	1325	436	-
[MnL <sup>2</sup> ].2H <sub>2</sub> O	3240 <sup>a</sup>	-	-	1560	-	1000	1665	1335	442	312
[CrL <sup>2</sup> Cl].H <sub>2</sub> O	3369 <sup>a</sup>	-	-	1530	-	1015	1640	1340	450	315
[FeL <sup>2</sup> Cl].H <sub>2</sub> O	3298 <sup>a</sup>	-	-	1540	-	1030	1630	1345	425	335
[ZnL <sup>2</sup> ].2H <sub>2</sub> O	3369 <sup>a</sup>	-	-	1580	-	1035	1650	1330	425	340



a= Absorption due to water molecule

#### 4.2 <sup>1</sup>H NMR spectra

<sup>1</sup>H NMR Spectra of ligands (H<sub>2</sub>L<sup>1</sup> and H<sub>2</sub>L<sup>2</sup>) are recorded in DMSO-d<sub>6</sub>, showed two sharp singlet at δ10.6 and δ11.2 ppm are assigned to –OH and –NH protons, respectively. The downfield shift of –OH signal can be attributed to intramolecular hydrogen bonding (Figure -1). The NMR spectrum of the ligand also exhibits a NCH proton at δ 8.52 ppm, isonicotinoyl proton at δ8.15ppm and δ8.95 ppm (each as a doublet), benzene ring proton at δ6.5-8.40 (multiplets) and an addition peak for –CH<sub>3</sub> protons (in H<sub>2</sub>L<sup>2</sup>) at δ3.75 ppm. The <sup>1</sup>H NMR Spectra of the complexes cannot be obtained due to interference in their magnetic properties. However it can be seen in the complexes of [ ZnL<sup>1</sup>].2H<sub>2</sub>O, the proton signal of –OH an –NH disappears, while other signals donot show significant changes as compared to those of the ligands. This suggest that the –OH and carbonyl group coordinates to metal ions through keto-enol tautomerisation and deprotonation. This is consistent with the result of IR spectra of the compound. The <sup>1</sup>H NMR spectra of other complexes cannot be obtained due to interference in their paramagnetic properties.

#### 4.3 Electronic spectra and magnetic moments

The assignment of various d-d transitions and charge transfer bands in the spectra of the complexes are based on the works of Lever [15] and Drago[16]. The Electronic spectra of all complexes were recorded in DMF at room temperature.

The electronic spectra of Cr(III) complexes exhibits three bands at 18880-19120 cm<sup>-1</sup> (ν<sub>1</sub>), 24860-25470 cm<sup>-1</sup> (ν<sub>2</sub>), and 39900-41055 cm<sup>-1</sup> (ν<sub>3</sub>), corresponding to <sup>4</sup>A<sub>2g</sub> → <sup>4</sup>T<sub>2g</sub>(F) and <sup>4</sup>A<sub>2g</sub> → <sup>4</sup>T<sub>1g</sub>(F) and <sup>4</sup>A<sub>2g</sub> → <sup>4</sup>T<sub>1g</sub>(P) transitions respectively, characteristics of octahedral geometry around the Cr(III) ion [20]. The magnetic moment value obtained for Cr(III) complexes lies in the range of 3.89-3.98BM which corresponds to octahedral field.

The electronic spectra of Mn(II) complexes shows two bands at 18980-19200 cm<sup>-1</sup> (ν<sub>1</sub>), and 30800-32000 cm<sup>-1</sup> (ν<sub>2</sub>), assignable to <sup>6</sup>A<sub>1g</sub> → <sup>4</sup>T<sub>2g</sub>(<sup>4</sup>G), and <sup>6</sup>A<sub>1g</sub> → <sup>4</sup>T<sub>1g</sub>(P) (ν<sub>2</sub>) transitions respectively, corresponding to an octahedral geometry [17-18]. The room temperature magnetic moments of Mn(II) complexes found in the region of 5.60-5.75 BM corresponding to fine unpaired electrons, which is indication of high spin Mn(II) octahedral complex and also the non involvement of orbital contribution[19].

The electronic spectra of Fe(III) complexes displays bands at 11200-11440 cm<sup>-1</sup> assignable to d-d transitions while band at 14460-15960 cm<sup>-1</sup> and 24900-25689 cm<sup>-1</sup> refers to charge transfer spectra. The high magnetic susceptibility of Fe(III) complexes

found in the range of 4.58-4.64 BM are consistent with octahedral geometry.

Zn(II) complexes are diamagnetic as expected for the d<sup>10</sup> configuration and has not shown any d-d transitions.

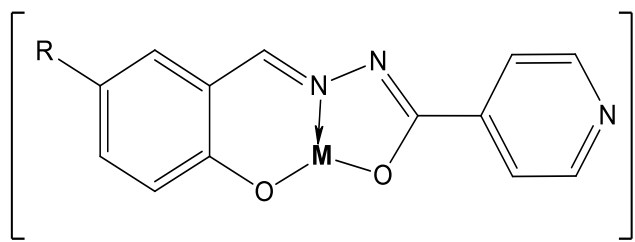
#### 4.4 EPR Spectra

The solid state EPR spectra of Mn(II) complexes at 300 K exhibits a sextet due to electron spin-nuclear spin coupling(I=5/2)[21]. The observed g value of the complexes are very close to the spin free value of 2.0023, which corresponds to the absence of spin orbital coupling in the ground state with <sup>6</sup>A<sub>1</sub> term without sextet term of high energy. The hyperfine structure corresponds to an isotropic coupling constant (A<sub>iso</sub>=91 × 10<sup>-4</sup> cm<sup>-1</sup>) which is consistent with octahedral geometries of Mn(II) complexes, since A<sub>iso</sub>(<sup>55</sup>Mn) in tetrahedral sites is 20-25% lower than octahedral sites [22].

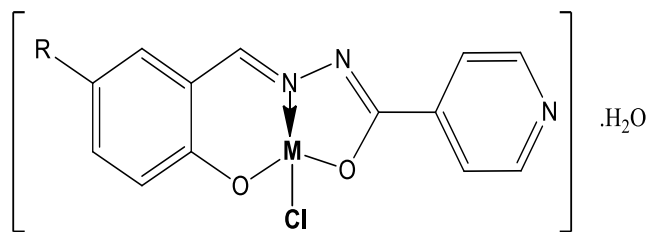
The EPR spectrum parameters obtained from Fe(III) complexes in the solid state at 300 K consist of a single broad line and the isotropic g values calculated from the isotropic spectra of the complexes are found to be 2.220 and 2.224 indicating high octahedral geometries. [23].

#### 4.5 Thermal Analysis

TG and DTA studies were carried out on the ligand and complexes in the temperature range 25-700 °C. Thermal analysis shows that there are two endothermic peaks in the DTA curve of the ligand . The first appeared at ≈170 °C (H<sub>2</sub>L<sup>1</sup>) and at ≈185 °C (H<sub>2</sub>L<sup>2</sup>) are the melting point of the ligands because no loss of weight was observed with TG curve. The second peak appeared at 350 °C where the weight loss on the corresponding curve indicates decomposition of the ligands, which continues up to 490 °C. All the complexes decomposes in three steps as shown by The TG curve. The Mn(II), Cr(III), Fe(III) and Zn(II) complexes lose their weight in the temperature range 120-150 °C, corresponding lattice water molecule, leading to the formation of anhydrous chelate. The presence of water molecule in the lattice suggested by IR spectra is also confirmed by thermogravimetric analysis. The organic moiety decomposed further with increasing temperature. Although the decomposed fragments of ligand could not be approximated owing to continuous weight loss as indicated by horizontal plateau on the TG curve for all complexes. The complete decomposition of ligand occurred at ≈ 480 °C in all complexes. At the end of final step, i.e. 550-700 °C stable metallic oxides were found [24]. The decomposition temperature of complexes as higher than ligand indicates that the thermal stability of the complexes is increased due to the ligand coordinated with metal ion to form a ring. Summarizing our result we propose a plausible structure of these complexes as shown in Figure-2 (a & b).



(a)  $[ML^1] \cdot 2H_2O$  (R=H) and  $[ML^2] \cdot 2H_2O$  (R=CH<sub>3</sub>) where M= Mn(II), Zn(II)



(b)  $[ML^2Cl] \cdot H_2O$  (R=H) and  $[ML^2Cl] \cdot H_2O$  (R=CH<sub>3</sub>) where M= Cr(III), Fe(III)

**Figure-2(a & b): Proposed structure of the complexes**

#### ACKNOWLEDGEMENTS

The authors are very much thankful to Prof. Ashok K. Prasad from Department of Chemistry, Delhi University for providing all laboratory and research facilities.

#### REFERENCES

- [1] I.G. Ribeiro, K.C.M. da Silva, S.C. Parrini, A.L.P. de Miranda, C.A.M. Fraga, E.J. Barreiro, *Eur. J. Med. Chem.*, 33, 1998, pp. 225-255.
- [2] D.R. Richardson, P.V. Bernhardt, *J. Biol. Inorg. Chem.*, 4, 1999, pp. 226-273.
- [3] S. G. Kuçukguzel, S. Rollas, I. Kuçukguzel, M. Kiraz, *Eur. J. Med. Chem.*, 34, 1999, pp. 1093-1100.
- [4] U. O. Ozmen, G. Olgun, *Spectrochim. Acta A* 70, 2008, 641-645.
- [5] P. G. Avaji, CH. V. Kumar, S. A. Patil, K. N. Shivananda, C. Nagarajun, *Eur. J. Med. Chem.*, 44, 2009, 3552-3559.
- [6] L. M. Lima, F. S. Frattani, J. L. dos Santos, H. C. Castro, C. A. M. Fraga, R. B. Zingali, *Eur. J. Med. Chem.*, 43, 2008, 348-356.
- [7] G. Visbal, E. Marchán, A. Maldonado, Z. Simoni, M. Navarro, *J. Inorg. Biochem.*, 102, 2008, 547-554.
- [8] C. Roullier, C. K. Marylene, W. Pierr Van De, L. L. D. Françoise, B. Joel, *Bioorg. Med. Chem. Lett.*, 20, 2010, 4582-4586.
- [9] J. K. Amartey, I. Al-Jammaz, B. Al-Otaibi, B. Esguerra, *Nucl. Med. Bio.*, 29, 2002, 817-823.
- [10] B. S. Garg, P. K. Singh, J. Sharma, *Synth. React. Inorg. Met. Org. Chem.*, 30, 2000, 803-813.
- [11] P. K. Singh, D.N. Kumar, *Spectrochim. Acta., Part A*, 64, 2006, 853-858.
- [12] A.I.Vogel, "A text book of Quantitative Inorganic Chemistry "3rd Ed., ELBS London, 1961.
- [13] W.J. Geary, *Coord. Chem. Rev.*, 7, 1971, 81-85.
- [14] K. K. Nakanishi, *Infrared Absorption Spectroscopy*, Holden-Day Inc., Nankodo Co Ltd, San Francisco, Tokyo, 1962.
- [15] A.B.P. Lever, *Inorganic electronic spectroscopy*, Elsevier, London, 1968.
- [16] R.S.Drago, *Physical methods in Inorganic Chemistry*, Reinhold, London, 1965.

- [17] C.J.Keidt,G.F.Koster and A.N. Johnson,*J. Am. Chem. Soc.* ,80, 6471 , 1958.
- [18] N. Naskar, S. Biswas, D. Mishra, B. Adhikary, L.R. Falvello, T.Soler, C.H. Schwalbe, S. K. Chattopadhyay, *Inorg. Chim. Acta.*, 23,831, 2004.
- [19] B. F. Figgis and J.Lewis, *Progr. Inorg. Chem.*, 6, 37, 1964.
- [20] R.S. Drago, D.W. Meek, M.S.Joosten, and L. Laroche, *Inorg.Chem.*, 2, 124, 1963.
- [21] E.T.Allen, *J.Chem.Phys.* 43, 3820(19650).
- [22] B.A. Goodman and J.B. Raynor, *Adv.Inorg.Chem. Radiochem.*13, 135, 1970.
- [23] T.W. Swanson and V.M. Laurie, *J.Phys. Chem.*, 69, 244, 1965.
- [24] W. W. Wendlandt, *Thermal Method of Analysis*, Interscience, NewYork, 1964.

#### AUTHORS

**First Author** – Dr.Kamalika Banerjee Associate Professor, School of Sciences, Chemistry, IGNOU, Maidan Garhi, Delhi-110068, India, Tel No.: +91-11-29532167, email: kamalika@ignou.ac.in

**Second Author** – Dr.Pramod Kumar Singh Associate Professor, Department of Chemistry, Kirorimal College, University of Delhi, Delhi-110007, India, Tel No.:+918800355311.Fax No:+9127626579, email: dr.pramodksingh@yahoo.com

**Third Author** – Sangeeta Singla Associate Professor, Department of applied Science and Humanities, Dronacharya College of Engineering, Gurgaon- 122001, Haryana, India Tel. No: +91-9811172817, email: singlasangeeta65@yahoo.com

**Correspondence Author** – Sangeeta Singla Associate Professor, Department of applied Science and Humanities, Dronacharya College of Engineering, Gurgaon- 122001, Haryana, India, Tel. No: +91-9811172817, email: singlasangeeta65@yahoo.com

# Approach of Crashing Critical Activity (CCA) and Stretching Non-critical Activities (SNA) of Time Cost Trade off problems using Critical Path Method

Dr.P.Hima Bindu

Humanities & Sciences, Shadan Womens College of Engg.&Tech

**Abstract:** The three important objectives of any project are time, cost and quality. In today scenario delivering projects in least possible time at least cost within maximum available budget has got a critical issue to the manager. Firstly, two different approaches crashing critical activities (CCA) and stretching non critical activities (SNA) are compared to illustrate the gauge of which approach to be used to complete the project within the maximum available budget and within least number of steps. Depending on five construction projects it is observed that the SNA approach is better than CCA approach. Secondly, evaluation of projects with respect to the criteria is generated. Next these evaluations are compared with respect to the criteria. Finally, the interactive technique is used for the selection of most desirable project. A numerical example is presented to illustrate the approaches and selection of desirable project out of the given projects.

**Index Terms:** Critical path, Crashing activities, Stretching activities, Multi criteria decision problem, Stochastic dominance

## I. Introduction

Tradeoff between project duration and total cost are extensively discussed in the project scheduling literature because of its practical significance. It is generally realized that when project duration is compressed, the project requires more labor, increase more productive equipment, demanding procurement and construction management and at the same time the cost will also increase. The main objective of critical path method is to establish a feasible and desirable relationship between the time and cost of the project by decreasing the target time and taking into account the cost of expending as presented by Taha (1). Several studies conducted on critical path method for time cost trade off, like Anagnostopoulos (2) Ke at al (3) claimed in the real life projects, both trade off between project cost and project completion time and the uncertainty of the environment are considerable aspects for decision maker.

The two different approaches are presented for time cost trade off to complete the project in shortest possible duration at smallest cost within the available budget. They are Crashing Critical Activities (CCA), Stretching Non-Critical Activities (SNA). The first approach was developed along with critical path method for planning and controlling large scale projects. Then crashing is selecting the lowest cost slope activities which shorten the critical path, this procedure is repeated until the project has been reduced sufficiently or the cost to shorten the project exceeds the benefits. The second approach will reduce the cost of the project by stretch or increase any non-critical activity by certain amount without extending the project, and the non-critical activities can be stretched until all the slack in the network is used up. Stretching non-critical activities crash all the activities in the project parallel to find the shortest possible project duration by avoiding the intermediate steps.

These approaches have been applied on five different construction projects as mentioned in table-I below. Where the data is collected from various companies, where the companies are specialized in designing and execution of bridges, housing complexes, towers, industrial buildings, plants, dams, etc.. These companies are willing to construct the new projects, with maximum available budget within the given time. Various heuristically approaches were presented by Siemans (4) and Moselhi and Deb (5). Multicriteria techniques are widely used in project scheduling problems. Nowak (6) proposed a technique based on simulation model, stochastic dominance rules and multi criteria aggregation procedure. In paper (7) a new discrete resource time cost quality constrained trade off problem, renewable and non-renewable resources are considered. And in paper (8) the interactive technique is used for the selection of the most desirable resources allocation.

## II. Problem Formulation

Crashing critical activities as discussed earlier finds step-by-step activities to reduce the project completion time. This stepwise reduction of the project duration eventually leads to shortest possible project duration and its associated cost. However, if we want to directly find the shortest possible project duration by avoiding the intermediate steps, a simpler procedure represent with stretch non-critical activities which simultaneously crash all activities at once. This also yields the shortest project duration. However, the expenses of crashing all activities needs more amount, as it is necessary to crash activity to finish the project in shortest time. So we must stretch non-critical activities to reduce the cost of the project completion.

Both the approaches aims to reduce the project duration at the smallest total cost, and these approaches identify critical and non-critical activities. The normal time and cost as well as crash time and cost must be found for all activities in order to find the cost slope for the two approaches. These two approaches find the expected project completion time within maximum available budget. Crashing critical activities is the expression of crashing the critical path activities to reduce the completion time of project duration gradually, while stretching non-critical activities crash all activities simultaneously to yield the shortest possible duration of project completion

and stretching the non- critical activities to reduce the total cost. Crashing critical activity starts to crash the critical activity that has the least cost slope to reduce the project duration at least cost. While stretching non – critical activity depends on the stretching non-critical activity that has greatest cost slope to obtain the greatest saving. Crashing critical activity can obtain the desired project completion time at least cost and also obtain the shortest possible duration to complete the project at least cost within the maximum available budget, while stretching non – critical activity obtains only the shortest duration at least cost within the maximum available budget. Stretching non – critical activity requires less computation as compared to crashing critical activity because crashing critical activity will be by virtue of crashing one time unit from critical activity that has smallest cost slope.

The procedure proposed for the desirable project consists of three steps. First, evaluations of projects with respect to the criteria are generated. Next, these evaluations are compared with respect to the criteria. Finally, the interactive technique is used for the selection of the most desirable resource allocation. The steps required to perform the analysis are , the approach uses the evaluations of projects with respect to criteria. One of the most important point is identifying appropriate probability distribution for the input data. Usually, it requires analyzing the data and fitting these data to distributions. Sometimes, however, such data are not available and an appropriate distribution has to be selected according to the decision maker’s or expert’s judgment. Once the project evaluations are obtained, the relations between the projects with respect to the criteria can be analyzed. Two methods are usually used for comparing uncertain outcomes: mean risk analysis and stochastic dominance. The former is based on two criteria: one measuring expected outcome another representing variability of outcomes. In the stochastic dominance approach random variables are compared by point wise comparison of their distribution functions. In this paper both techniques are used. While the stochastic dominance is employed for constructing rankings of projects with respect to each criterion, mean risk technique is used when a final solution is chosen.

### III. Notations

$x_{ijk} = 1$  if activity  $(i,j)$  is executed in mode  $k$   
 $= 0$  otherwise

$m$ = number of modes

$t_{ijk}$  = duration of activity  $(i,j)$  in mode  $k$

$r_{ijk}$  = the amount of renewable resource  $r$

$P_r$  = price of the renewable resource  $r$

$c_{ijk}$  = cost of the activity  $(i,j) = t_{ijk} \times r_{ijk} \times P_r +$  the cost of non renewable resources

$q_{ijk}$  = quality of activity  $(i,j)$  in mode  $k$

$M_T$  = maximum time to complete the project

$B_{max}$  = maximum available budget

$R$  is the project activities

$T$  is the shortest possible duration to complete the project at least cost within the maximum available budget

$F$  is the desired project completion time at least cost

$N_T$  is the normal time for an activity

$C_T$  is the crash time for an activity

$N_c$  is the normal cost for an activity

$C_c$  is the crash cost for an activity

$U_i$  is the cost slope for an activity

$CP$  is the critical path

$TC_N$  is the total cost to complete the project in normal conditions

$NC_j$  is the normal cost for non – critical activity  $j$ , where  $j = 1, 2, \dots$

$TC_a$  is the total cost complete the project by crashing all activities (crash conditions)

$TE_c$  is the extra cost that added to all crash critical activities

$D_{rs}$  is the maximum reduction in duration for critical activity  $S$

$U_s$  is the cost slope for the critical activity  $S$

$TC_c$  is the total cost to complete the project using obtained critical activity

$TSC_n$  is the total saving cost obtained by stretching critical activity

$D_{rx}$  is the maximum stretching in duration for non- critical activity  $x$

$l_{ij}$  = lower bound for quality of activity  $(i,j)$

In normal conditions the critical path of project network is given by

$$CP = \sum_{q=1}^L N_{Tq}$$

Also the total cost in normal conditions is given by

$$TC_N = \sum_{j=1}^n N_{Cj}$$

The total cost of the project after crashing

$$TC_a = \sum_{i=1}^n C_{Ci}$$

Critical path of the project after crashing

$$CP_c = \sum_{q=1}^L CT_q$$

The total cost after crashing the critical activity

$$TC_C = TC_N + TC_E$$

The total extra cost that adding to crash critical activities

$$TE_c = \sum_{s=1}^y D_{rs} U_s$$

Total saving cost obtained by stretching non-critical activities

$$TSC_n = \sum_{xs=1}^z D_{rx} U_x$$

Total cost of the project within the given time by stretching non- critical activity

$$TCS_n = TC_a - TSC_n$$

Three mathematical models using 0-1 integer linear programming are

$$(i) \text{Max } z_1 = \left[ \prod_{(i,j) \in A} \left[ \sum_{k=1}^m q_{ijk} x_{ijk} \right] \right]^{\frac{1}{|A|}},$$

Subject to constraints

$$\sum_{k=1}^m x_{ijk} = 1$$



$$\sum_{u \in N_j} uy_{ju} - \sum_{w \in N_i} wy_{iw} \geq \sum_{k=1}^m t_{ijk} x_{ijk}$$

$$\sum_{u \in N_n} uy_{nu} \leq M_T$$

$$\sum_{(i,j) \in A} \sum_{k=1}^m c_{ijk} x_{ijk} \leq B_{\max}$$

$$\sum_{k=1}^m q_{ijk} x_{ijk} \geq l_{ij}$$

where  $(i,j)$  is an activity,  $x_{ijk} = 0$  or 1 for each activity  $(i,j)$  executed in each mode  $k$  and  $y_{iu} = 0$  or 1 for each event  $i$  and for each  $u \in N_i$ ,

$$(ii) \text{ Min } Z_2 = \sum_{k=1}^m c_{ijk} x_{ijk}$$

Subject to

$$\sum_{k=1}^m x_{ijk} = 1$$

$$\sum_{u \in N_j} uy_{ju} - \sum_{w \in N_i} wy_{iw} \geq \sum_{k=1}^m t_{ijk} x_{ijk}$$

$$\sum_{u \in N_n} uy_{nu} \leq M_T$$

$$\sum_{k=1}^m q_{ijk} x_{ijk} \geq l_{ij}$$

Where  $(i,j)$  is an activity,  $x_{ijk} = 0$  or 1 for each activity  $(i,j)$  executed in each mode  $k$  and

$y_{iu} = 0$  or 1 for each event  $i$  and for each  $u \in N_i$ ,

$$(iii) \text{ Min } z_3 = \sum_{u \in N_n} uy_{nu}$$

$$\sum_{k=1}^m x_{ijk} = 1$$

$$\sum_{u \in N_j} uy_{ju} - \sum_{w \in N_i} wy_{iw} \geq \sum_{k=1}^m t_{ijk} x_{ijk}$$

$$\sum_{(i,j) \in A} \sum_{k=1}^m c_{ijk} x_{ijk} \leq B_{\max}$$

$$\sum_{k=1}^m q_{ijk} x_{ijk} \geq l_{ij}$$

where  $(i,j)$  is an activity ,  $x_{ijk} = 0$  or 1 for each activity $(i,j)$  executed in each

mode  $k$  and  $y_{iu} = 0$  or 1 for each event  $i$  and for each  $u \in N_i$ .

#### IV. Solution Procedure

Firstly, applying both the approaches to the construction project by drawing the project network, computing the cost slope for each activity and crashing all the activities simultaneously. Once again, draw the project network after crashing all the activities and determine the critical path, critical activities and non critical path, now compute the new total cost after crashing all activities in the project. Start with those non critical activities that yield the greatest savings those with the greatest cost slope. The non critical activities can be stretched up to their normal time until all the slack in the different non critical paths network is used up and then the saving cost of stretching all non critical activities are found and finally cost of project completion within maximum available budget is computed. And two approaches are compared for minimum number of steps to complete the project. Secondly, stochastic dominance and multi criteria decisions are used to select the best desirable project.

#### V. Numerical Example

Five different construction projects have been selected for illustration of above

**Table I : The five different construction projects**

Project No.	Project Type	Project Name	Start date of the Project	Expected Completion time
1	House Construction	SSR Constructions	01/01/2011	30 weeks
2	Plant Construction	VGR Constructions	20/01/2011	27 weeks
3	House Construction	Reddy Constructions	10/02/2011	29 weeks
4	Plant Construction	NNR Group	01/01/2011	80 weeks
5	Plant construction	SiddiVinayaka constructions	11/03/2011	70 weeks

The Project-I is considered to illustrate the above said data (Housing construction-SSR Constructions) is summarized in Table-II in which there are 11 activities with maximum available budget ₹. 78,500,with shortest possible duration of 17 weeks to complete the project at least cost within maximum available budget and desired project completion time is 18 weeks

**Table II: Data obtained from Project I**

SNo	Activity	Predecessor	Normal Time	Crash Time	Normal Cost	Crash Cost	Max Reduction in time	Cost Slope
-----	----------	-------------	-------------	------------	-------------	------------	-----------------------	------------

1	P <sub>1</sub>	---	3	2	5000	7000	1	2000	
2	P <sub>2</sub>	P <sub>1</sub>	4	2	4000	5000	2	500	
3	P <sub>3</sub>	P <sub>2</sub>	4	4	7000	7000	0	---	
4	P <sub>4</sub>	P <sub>2</sub>	3	1	3000	5000	2	1000	
5	P <sub>5</sub>	P <sub>2</sub>	5	2	6000	10500	3	1500	
6	P <sub>6</sub>	P <sub>5</sub> , P <sub>3</sub>	4	3	8000	10000	1	2000	
7	P <sub>7</sub>	P <sub>4</sub>	3	1	4000	5500	2	750	
8	P <sub>8</sub>	P <sub>7</sub>	6	4	6000	9000	2	1500	
9	P <sub>9</sub>	P <sub>6</sub>	7	4	5000	8000	3	1000	
10	P <sub>10</sub>	P <sub>8</sub> , P <sub>9</sub>	4	2	6000	7500	2	750	
11	P <sub>11</sub>	P <sub>3</sub> , P <sub>5</sub>	9	7	3000	4000	2	500	
<b>Total Cost</b>					<b>57,000</b>	<b>78,000</b>			

Project –I network diagram in Fig -1, which is considered for explaining the mechanism of Crashing the Critical Activity (CCA) and Stretching the Non-critical Activity (SNA)

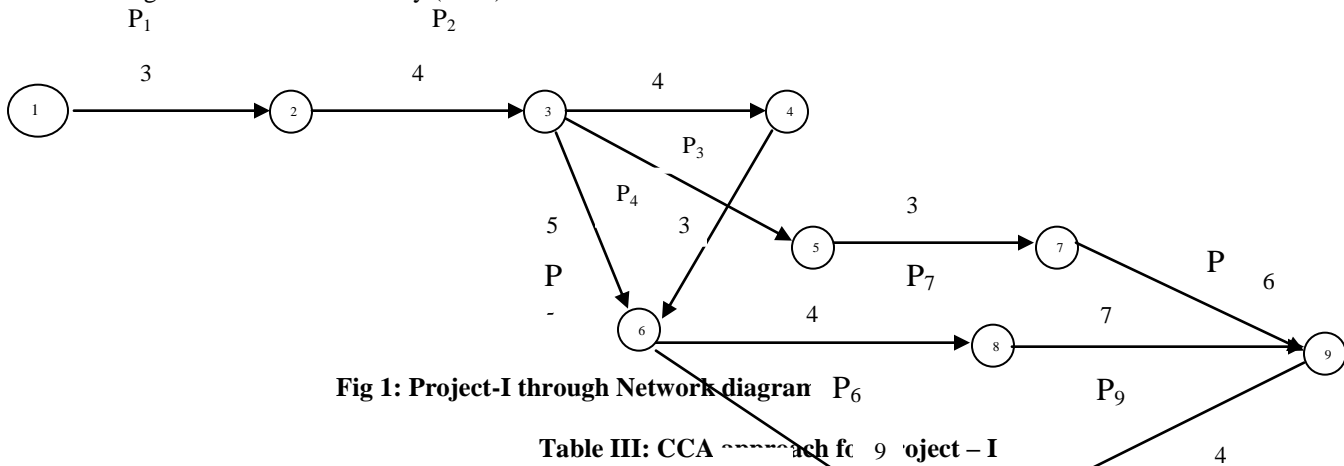


Fig 1: Project-I through Network diagram

Table III: CCA approach for Project – I

Crashed Activity	Normal Project duration	Cost Slope	Total Cost with addition of extra cost
P <sub>2</sub>	22	500	57,500
P <sub>2</sub>	21	500	58,000
P <sub>10</sub>	20	750	58,750
P <sub>10</sub>	19	750	59,500
P <sub>9</sub>	19	1000	60,500
P <sub>9</sub>	19	1000	61,500

P <sub>9</sub>	19	1000	62,500
P <sub>5</sub>	19	1500	64,000
P <sub>1</sub>	18	2000	66,000
P <sub>6</sub>	18	2000	68,000
P <sub>7</sub>	17	750	68,750

The total extra cost that added to crashed critical activities

$$TE_c = \sum_{s=1}^Y D_{rs} U_s$$

i.e.,  $TE_c = ₹. 11,750$  and the steps to complete the project within the shortest possible duration with maximum available budget by CCA approach is 11.

**Table IV : SNA approach for Project-I**

Stretched Non-critical Activity	Normal Project duration	Cost Slope	Total Cost with subtraction of saving cost
P <sub>5</sub>	15	1,500	75,500
P <sub>8</sub>	15	1,500	72,500
P <sub>4</sub>	15	1,000	70,500
P <sub>7</sub>	15	750	69,750
P <sub>11</sub>	17	500	68,750

Total saving cost obtained by stretching non-critical activities

$$TSC_n = \sum_{xs=1}^z D_{rx} U_x$$

i.e.,  $TSC_n = ₹. 9,750$  and the steps to complete the project within the shortest possible duration with maximum available budget by SNA approach is 5.

We generate the set of efficient projects by comparing evaluations of projects employing stochastic dominance rules as stated above. Firstly, evaluations of projects with respect to the criteria are generated. Next, these evaluations are compared with respect to the criteria. Finally, the interactive technique is used for the selection of the most desirable resource allocation. The steps required to perform the analysis are described below.

The efficient set consist of five projects, namely

$Z = \{proj(1), proj(2), proj(3), proj(4), proj(5)\}$ , data related to the five projects are given in the following table

**TableV : Time, cost & Quality of 5 construction Projects**

Projects	Time	Cost	Quality
Proj(1)	27	57,000	0.95

Proj(2)	63	1,86,500	0.91
Proj(3)	35	1,58,500	0.88
Proj(4)	77	51,20,000	0.92
Proj(5)	98	3,45,000	0.89

Criterion :

$X_1$  : Time will not exceed 90 days

$X_2$  : Cost will not exceed Rs. 2,00,000

$X_3$  : Quality will not be less than 0.94

The set of projects satisfying criterion  $X_1$  is

$Z_1 = \{ \text{proj}(1), \text{proj}(2), \text{proj}(3), \text{proj}(4) \}$

The best project satisfying the criterion from set 1 is proj(1)

The set of projects satisfying criterion  $X_2$  is

$Z_2 = \{ \text{proj}(1), \text{proj}(2), \text{proj}(3) \}$

The best project satisfying the criterion from set 2 is proj(1)

The set of projects satisfying criterion  $X_3$  is

$Z_3 = \{ \text{proj}(2), \text{proj}(3), \text{proj}(4) \}$

The best project satisfying the criterion from set 3 is proj(4)

If the decision maker needs to select a project from the above set of projects, then he would select project (1) as the final by giving preference to quality and cost constraint

**Table VI: Data presented to decision maker**

Projects	Time	Cost	Quality
Proj(1)	27	57,000	0.95
Proj(4)	77	51,20,000	0.92

We conclude by saying proj (1) is the best project. That is SSR Construction projects are chosen compared to Reddy Constructions projects.

## VI. Conclusion

The time cost trades off problems are explained through CCA and SNA in this paper. Based on five projects and above calculations shows that the minimum number of steps required to complete the project within the maximum available budget is SNA which could complete the project in least number of steps than CCA. Therefore, we can conclude that SNA is a faster and easier to complete the project within the maximum available budget. And by using interactive technique we conclude that project-I is the best desirable project.

## References

- 1.Taha,H.A.,2007,Operations Research an Introduction.8<sup>th</sup> Edn, Person Prentice Hall, Saddle River, New jersey
2. Anagnostopoulos, K.P., 2002.A fast algorithm for time compression in project scheduling. Operations Research., 2;407-417
3. Ke,H.,W.Ma and Y.Ni,2009.Optimization models and GA-based algorithm for stochastic time cost trade off problem.Applied math.Comput.,215;308-313
4. Siemans, N. A simple CPM time –cost trade off algorithm, Management science. 1971, 17, 354-363.
5. Moselhi and Deb. Project selection considering risk construction management and economics 1993, 11, 45-52
6. Nowak, M. Investment projects evaluations by simulation and multiple criteria decision aiding procedure, Journal of civil engineering and management, 2005,11; 193-202
7. N.Ravi Shankar, M.M.K.Raju, P.Himabindu, Discrete time, cost and quality trade off problem with renewable and non renewable resources, International journal of computational science and mathematics, 2010, 285-290
8. N.Ravi Shankar, M.M.K.Raju, P.Himabindu, Time, cost and Quality Trade-off Analysis in Construction of Projects,Contemporary Engineering



**Author**

**Name :** Dr.P.Hima Bindu, M.Sc, M.Phil, Ph.D

**Associated Institute:** Shadan Womens College of Engineering & Technology, Khairthabad, Hyderabad.

**Email:**himabindu\_p71@rediffmail.com

**Contact No.:**9908545488

# Evaluation of Tensile and Interfacial Strength of Coconut Palm Leaf Midrib as a potential Reinforcement for Plastics

Neeraj Dubey\*, Geeta Agnihotri\*

\*Department of mechanical engineering  
MANIT, Bhopal, 462051, MP, India

**Abstract-** In the present scenario world is facing a serious problem of the polymer wastes due to its non-biodegradable nature. Production of the natural fiber composite is one of the noble approaches to minimize this problem and modify the polymer based materials as partially biodegradable. In last two decades many researchers have been investigating and exploring new natural fibers and their composites with polymers as matrix material. Due to various advantages and eco-friendly nature, natural fiber composites are replacing conventional materials and glass fibers in moderate strength applications. Strength of natural fiber/polymer composites highly depend upon interfacial strength between hydrophilic fiber and hydrophobic polymers. In this paper potential of a new natural fiber as midrib of coconut palm leaf is investigated for the purpose of synthesis of a new natural fiber composite. Tensile properties of midribs and interfacial strength between midrib and polyester resin and critical embedded length are determined by tensile test and fiber pull-out test. Results show that midrib of coconut palm leaves have potential for development of natural fiber composite.

**Keywords** – Polymer matrix composites, Natural fibers, midrib of coconut palm leaf, Interfacial strength, Pull-out test

## I. INTRODUCTION

Plastics or polymers are replacing conventional materials like wood, metal, glass and ceramics and its application can be realized in many aspects of our lives. The advantages of plastics over conventional materials are ease of formability, Low processing temperature, very low density compared with metals, excellent surface finish and lack of corrosion. Due to advances in technology and growing global population production of plastics in the form of different products are also growing day by day. Worldwide production of plastic is approximately 140 million tons every year [1]. To increase the strength and performance of plastics, fibers are reinforced in it. Synthetic fibers like Carbon, Glass, Kevlar etc [2] are the most popular and commercial fibers used for reinforcement of plastics. Since most of the plastics (Polyethylene, polypropylene, polyvinyl chloride etc.) and synthetic fibers are non-biodegradable and build up in the surrounding at a rate of 25 tons per year which is proving to be a major ecological and environmental problem [1]. Also, Synthetic fibers require production of fiber itself and are dangerous to environment and health. With the increase of global crisis, ecological and environmental risk plant based natural fiber reinforced plastics have attracted much interest due to their potential of serving as alternative reinforcement to the synthetic fibers. Natural fibers like jute, flax, hemp, coir and sisal have gained a commercial value for the production of natural fiber reinforced plastics and also have proven as a greener substitute to glass fiber with excellent structural strength against moderate loading conditions [3].

Mechanical properties of a natural fiber composite mainly depend upon fiber matrix interface and efficiency of stress transfer from matrix to fibers as reported by many researchers [4-8]. Stress transfer ability from matrix to fiber depends upon interfacial adhesion between the fiber and the polymeric matrix [9, 10]. Experimental evaluation of interfacial strength between fiber and matrix material in a natural fiber reinforced composite, single fiber pull-out test is suggested by many researchers [11,12].

Midrib of coconut palm leaf (MCL) is the large, centre, main vein which helps to hold the leaf, facing the sun. It is commonly used for making brooms and also known as broom stick. Fig.1 shows picture of MCL and anatomical view of the cross section of midrib.

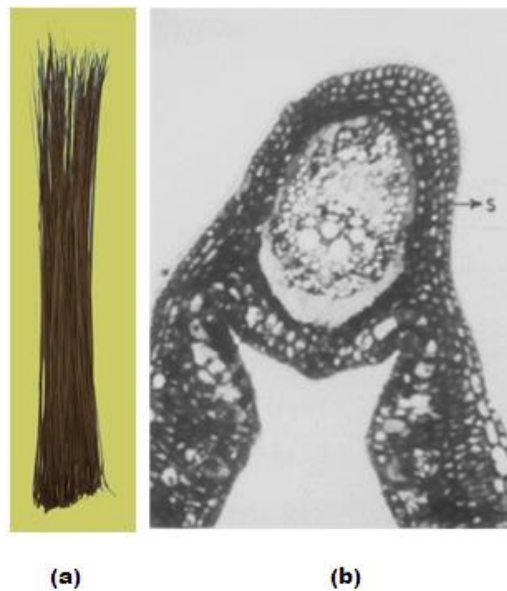


Figure1: (a) Midribs of coconut palm leaves (b) Anatomical view of cross section of midrib

Midrib of coconut palm leaf content 30% cellulose and 16% lignin and its properties is found appreciable for the purpose of reinforcement of plastics which can be used for different structural parts where moderate strength is required like door panels, roof sheets, packaging etc. [13,14]. This paper present a study on interfacial strength in a natural fiber composite and also investigate potential of MCL for the development of a new sustainable material as MCL reinforced polyester composite. Specimens are developed and tensile tests of MCL and polyester are conducted on an UTM also Single fiber pull out tests are conducted for determination of interfacial properties between MCL and polyester resin.

## II. MATERIAL AND METHOD

### A. Material

Midrib of coconut leaf (MCL) is supplied by Maharaja Broom Works, Bhopal, India. Polyester resin (Grade: VBR 4513) with Cobalt naphthanate as accelerator and methyl ethyle ketone peroxide (MEKP) as hardener is provided by Parmali Wallace Ltd. Bhopal, India. The resin has 500-600 cps viscosity, 15-25 min. gel time at 25°C and 38-40% volatile content. Healthy Midribs were selected from stock and cut uniformly. Selected part of midribs were finished with the help of a knife and then washed thoroughly in running water for clearing their surface from leaf residuals and other impurities. Midribs are allowed to dry first in sun light and than in hot air oven at 60° for 8 hrs.

### B. Preparation of specimens

Specimens for tensile testing of MCL were prepared by cutting selected (middle part) length of MCT from finished stock of MCL. Diameter of sticks was measured by a digital vernier scale. Gauge length of 150 mm was kept between griping ends, prepared by glass fiber reinforced sheets (Fig.2). Fig. 3 shows mould for casting of single fiber pull-out test specimens , which was developed on a surface plate by joining loose pieces of the tiles. A through hole is generated in the walls of the mould to support and facilitate extended length of the fiber embedded in the resin. Fig.4 shows specimens for single fiber pull-out test, five specimens for single fiber pull out test were prepared with cross-section 20x20 mm and gauge length can cut to a suitable length according to pull out strength.

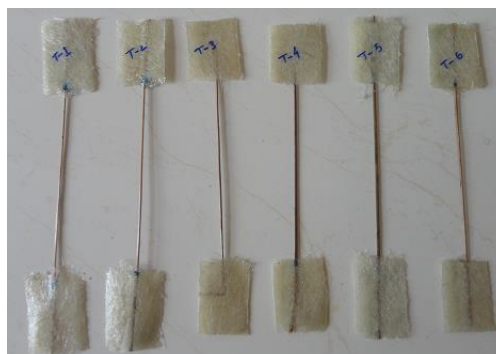


Figure 2: Specimens for tensile test of MCL fiber



Figure 3: Mould for single fiber pull-out test



Figure 4: Specimens for single fiber pull-out test

#### C. Density measurement

Ten samples of suitable size were chopped from midribs. Weight of each midrib measured with the help of Electronic Balance (Contech Instruments Ltd. Model No.ca 124). Volume of each sample was measured by liquid displacement method. Density of midrib was evaluated as average value of density calculated for each sample by weight upon volume.

#### D. Mechanical testing

To determine tensile strength of MCL fiber tensile test were conducted on at least five specimens of Midribs on Instron 3382 UTM at cross head speed of 5 mm/min. In order to identify interfacial shear strength and stress transfer capability of matrix to fiber single fiber pull out test were conducted at cross head speed of 2mm/min on the same UTM, on at least five specimens. Fig.5 and Fig.6 shows experimental set up for tensile test and single fiber pull out test respectively. All test were conducted at 23<sup>0</sup>C room temperature and 55% Humidity.

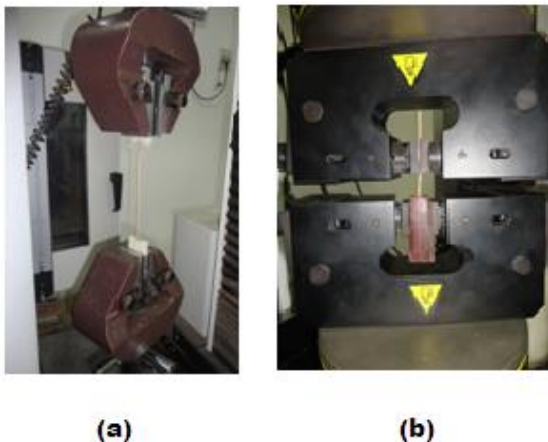


Figure 5: Experimental set up for (a) Tensile testing of MCL, (b) Single fiber pull-out test

### III. RESULTS AND DISCUSSION

#### A. Density of MCL

Fig. 6 shows a comparison of density and therefore, lightness of MCL fiber with other synthetic and natural fibers from reported journal data. It can be observed that density of midrib is about 1.3 gm/cm<sup>3</sup>, in comparison to density of other fibers it is lighter than

synthetic fibers like glass fiber, carbon fiber, Aramide, and natural fibers like Cotton, Flax, Hemp, Ramie, Sisal its density is equal to density of Coir fiber and Jute fiber as compared with reported journal data [15].

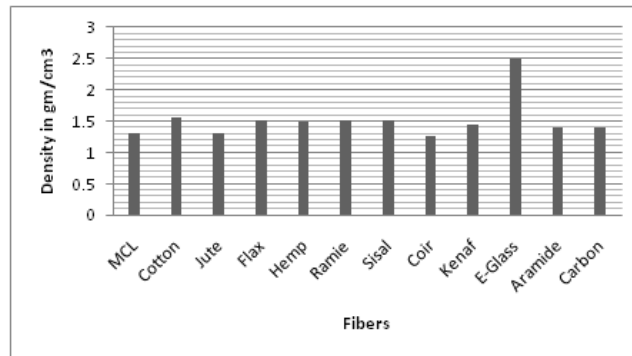


Figure 6: Comparison of density of MCL with other fibers

**B. Tensile strength of MCL**

Table I shows Mechanical properties of midrib as natural fiber. Higher strength of fiber than matrix material ensures the probability for improvement in the strength of plastic material.

Table I: Properties of MCL fiber

Density (in gm/cm <sup>3</sup> )	Tensile strength (in MPa)	Tensile modulus (in GPa)	Specific Tensile strength	Specific Tensile modulus	Elongation at failure (in %)
1.3	177.5	14.85	132.5	11	2

Fig.7 shows machine generated load deflection curve for five samples of the *Cocos nucifera* leaf midrib. It can be observed that stress-strain behavior follow the same trend for all samples and maximum elongation at failure is found 2% which shows that the failure pertains to brittle in nature.

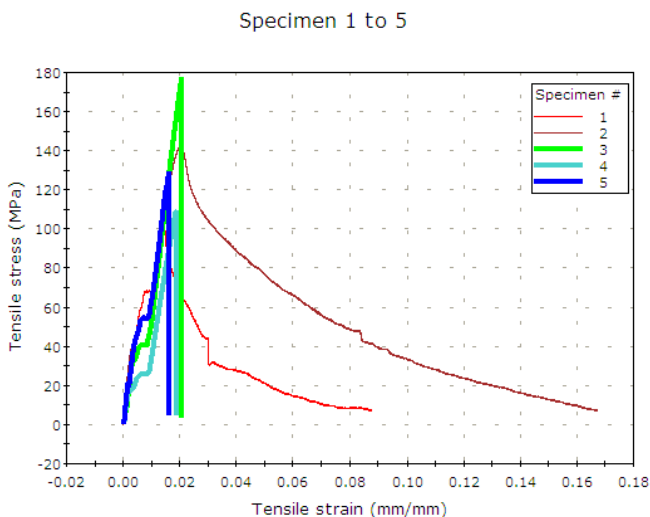


Figure 7: Stress-strain curves for MCL fiber

Specific properties calculated per unit density of fiber in which specific modulus of midrib is found more than coir and cotton fiber and in the range of jute fiber [3]. Mechanical properties of midrib highly depend upon nature. Even midribs of different leaves may have different properties [16]. Tensile test results shows maximum tensile strength of 177.5 MPa which is in the range of coir fiber strength, and tensile modulus of 14.85 GPa which is more than that for coir, cotton and sisal fibers but less than flax, hemp, ramie, jute and synthetic fibers as compared with reported journal data [3,17]. Midrib fiber can be considered as bundle of microfibrils having



lesser binding strength between them and increases probability of inner cells failure [18] due to this reason, midrib fiber with larger diameter would expected to have lesser strength but midribs are found strong enough for the moderate strength purposes.

**C. Single fiber pull-out strength**

The ability to transfer stress from the matrix to fiber at the interface is the main factor on which efficiency of a natural fiber reinforced polymeric composite depend [19, 20]. Various models have been reported by researchers for investigation of interfacial adhesion between fiber and matrix, an analytical model developed by Kharrat et al [21] assumes an elastic load transfer between the fiber and matrix (shear-lag model) for the first phase of the pull-out test (before debonding). After debonding, the fiber is extracted from the matrix against friction. To analyze this phenomena an analytical model, which assumes Coulomb friction at the fiber-matrix interface and Poisson’s effects on both fiber and matrix, was developed for the extraction process of fiber from matrix. This model was verified by the experiments for both stainless steel/polyester and stainless steel/epoxy composite systems. A fracture mechanics approach is proposed by Morrison et al [22] which can be applied to any fiber and matrix material to evaluate interfacial properties. Hutchinson and Jensen [23] proposed a pull-out model which was further developed by Marshal [24] in which unload- reload hysteresis is accounted for interfacial adhesion strength.

Mechanical properties of natural fiber reinforced polymeric composite strongly depend upon interfacial bonding because natural fibers are rich in hydroxyl groups like celluloses, hemicelluloses, pectin and lignin which causes strong polar and hydrophilic nature whereas polymers are significant hydrophobic in nature. Many researchers have studied interfacial characteristics of natural fiber composite by single fiber pull-out test [11,12,25]. In the present study single fiber pull- test is carried out for determination of interfacial bonding strength between MCL fiber and polyester resin as matrix material. Fig. 8 shows machine generated load-deflection curve for different specimens under single fiber pull-out test, maximum load ( $F_{max.}$ ) at which fiber debonding starts is observed as 210 N. Interfacial shear strength ( $\tau_c$ ) between matrix and fiber is calculated from equation (1) [25].

$$\tau_c = \frac{F_{max.}}{\pi dl} \tag{1}$$

Where  $d$  and  $l$  are the diameter and embedded length of the MCL. Results for fiber pull out test are shown in Table 2. Critical length ( $L_c$ ) can be calculated by Equation (2) [26].

$$L_c = \frac{\sigma d}{2\tau_c} \tag{2}$$

Where,  $\sigma$  is the tensile strength of the fiber,  $d$  is the diameter of fiber;  $\tau_c$  is the interfacial shear strength. Single fiber pullout strength in terms of interfacial shear strength  $\tau_c$  and critical embedded length  $L_c$  is determined as 2.23MPa and 5.9 cm respectively with polyester resin as matrix material. Table II shows result of single fiber pull-out test.

The critical length,  $L_c$ , is the minimum length that the fibers must have to strengthen a material to their maximum load [27]. In single-fiber pullout test, the pullout stress increases linearly with the fiber length embedded in the matrix. The fiber fails when the pullout stress reaches the fiber failure stress and the minimum embedded length at which the fiber fails is termed as the critical fiber length. Higher the fiber–matrix adhesion, lower the value of  $L_c$ .

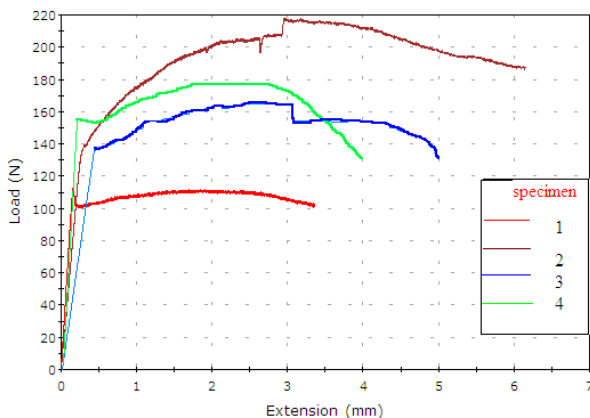


Figure 8: Machine generated Load-deflection curve for single fiber pull-out test

Table II: Single fiber pull-out test result

Diameter of MCL fiber	Embedded length of MCL	Maximum pull-out load	Interfacial shear strength ( $\tau_c$ )	Critical length (Lc)
1.5 mm	20 mm	210 N	2.23 MPa	5.9 cm

Result shows higher value of  $L_c$  hence poor bonding between fiber and matrix material which can be improved by suitable fiber surface topography alteration. Weak adhesion may also be due to presence of waxy layer on the surface of midrib of coconut leaf [11].

#### IV CONCLUSION

Present study shows potential of the midribs of coconut palm leaves as an alternate fiber for reinforcement of plastics and proposes development of a new natural fiber composite. MCL fiber is found lighter than the many commercial fibers and have potential to develop a lighter composite for moderate strength purposes such as furniture, packaging, boards, sheets etc. Tensile strength of the MCL is found competitive with the other natural fibers. Single fiber pull out strength and the critical length strongly recommend for suitable surface treatment of the fiber to enhance the interfacial bonding with hydrophobic polymers. Development of the MCL/plastic composite can also provide a source of employment in the rural areas of tropical countries like India, Sri Lanka, Indonesia etc.

#### ACKNOWLEDGMENT

The authors are indebted to the Parmali Wallace Ltd., Bhopal. MP, India for providing assistance for developing material and test facilities during the course of the investigation. Sincere thanks are due to Mr. Bhujang Seth, Mr. Balraj Singh Negi and Mr. Motilal Sharma of R&D Dept., Parmali Wallace Ltd.

#### REFERENCES

- [1] Fakrul Takian and Islam M.A., "Degradation Behavior of natural fiber reinforced polymer matrix composites", *Procedia Engineering*, 56: 795-800, 2013.
- [2] Kelly Anthony, "Composite materials after seventy years", *Journal of material science*, 41: 905-912. 2006
- [3] Wambua Paul, Ivens Jan, Verpoest Ignaas, "Natural fibers: can they replace glass in fiber reinforced plastics", *Composites Science and Technology*, 63:1259–1264, 2003
- [4] Hepworth D.G., Vincent J.F.V., Jeronimidis G., Bruce D.M., "The penetration of epoxy resin into plant fibre cell walls increases the stiffness of plant fibre composites", *Compos Part: A Appl Sci Manuf*, 31:599–601, 2000.
- [5] Alawar A., Hamed A.M., Al-Kaabi K., "Characterization of treated date palm tree fiber as composite reinforcement", *Compos Part B Eng*, 40(7): 601–606, 2009.
- [6] Rosa M.F., Chiou B-s, Medeiros E.S., Wood D.F., Williams T.G., Mattoso L.H.C., et al., "Effect of fiber treatments on tensile and thermal properties of starch/ethylene vinyl alcohol copolymers/coir biocomposites", *Bioresour Technol*, 100: 5196–5202, 2009.
- [7] Fu S-Y, Lauke B., "Effects of fiber length and fiber orientation distributions on the tensile strength of short-fiber-reinforced polymers", *Compos Sci Technol*, 56:1179–1190, 1996.
- [8] Rokbi M., Osmani H., Imad A., Benseddiq N., "Effect of chemical treatment on flexure properties of natural fiber-reinforced polyester composite", *Proc Eng*, 10:2092–2097, 2011.
- [9] Haque M.M., Hasan M., Islam M.S., Ali M.E., "Physico-mechanical properties of chemically treated palm and coir fiber reinforced polypropylene composites", *Bioresour Technol*, 100:4903–4906, 2009.
- [10] Torres F.G., Cubillas M.L., "Study of the interfacial properties of natural fibre reinforced polyethylene", *Polym Test J*, 24:694–698, 2005.
- [11] Brahmakumar M., Pavithran C., Pillai R.M., "Coconut fiber reinforced polyethylene composites: effect of natural waxy surface layer of the fiber on fiber/matrix interfacial bonding and strength of composites", *Composites Science and Technology*, 65:563–569, 2005.
- [12] Chen Hongyan, Miao Menghe, Ding Xin., "Influence of moisture absorption on the interfacial strength of bamboo/vinyl ester composites", *Composites: Part A*, 40: 2013–2019, 2009.
- [13] Satyanarayana K.G., Pillai C.K.S., Sukumaran S., Pillai G.K. "Structure property studies of fibres from various parts of the coconut tree" *Journal of materials science*, 17: 2453-2462, 1982.
- [14] Venkataswamy K.G., Pillai C.K.S., Prasad V.S., "Effect of weathering on mechanical properties of midribs coconut leaves", *J. Mater. Sci.*, 22: 3167–3177, 1987.

- [15] Eichhorn S.J., Baillie C.A., Zafeiropoulos N., “Review Current international research into cellulosic fibres and composites”, *Journal of materials science*, 36: 2107-2131, 2001.
- [16] Coroller Guillaume , Lefeuvre Anaële, Duigou Antoine Le , Bourmaud Alain , Ausias Gilles, Gaudry Thierry , Baley Christophe, “Effect of flax fibres individualisation on tensile failure of flax/epoxy unidirectional composite” ,*Composites: Part A*, 51: 62–70, 2013.
- [17] Taj Saira, Ali Munawar, Khan Shafi ullah, “Natural fiber-reinforced polymer composites”, *Proc. Pakistan Acad. Sc.*, 44:(2),129 -144, 2007.
- [18] Duval A., Bourmoud A. , Augier L., Baley C., “ Influence of the sampling area of the stem on the mechanical properties of hemp fibers”, *Mater. Lett* , 65: 797-800, 2011.
- [19] Caulfield D.F., Feng D., Prabawa S., Young R.A., Sanadi A.R., “Interphase effects on the mechanical and physical aspects of natural fiber composites”, *Die Angewandte Makromolekulare Chemie*, 272:57–64, 1999.
- [20] Cantero G., Arbelaz A., Llano-Ponte R., Mondragon I., “Effects of fibre treatment on wettability and mechanical behaviour of flax/polypropylene composites”, *Compos Sci Technol*, 63:1247–54, 2003.
- [21] Kharrat, M., Dammak, M., Charfi, A., “Mechanical Characterisation of Interface for Steel/Polymer Composite Using Pull-out Test: Shear-Lag and Frictional Analysis”, *J. Mater. Sci. Technol.*, 22(4): 552-558, 2006.
- [22] Morrison, J.K., Shah, S.P. and Jenq, Y.S., “Analysis of fiber debonding and pullout in composites”, *Journal of Engineering Mechanics*, 114 (2): 277 – 294, 1988.
- [23] Hutchinson, J. W., and Jensen, H. M., “Models of fiber debonding and pullout in brittle composites with friction”, *Mechanics of Materials*, 9: 139 – 163, 1990.
- [24] Marshall, D. B., “Analysis of fiber debonding and sliding experiments in brittle matrix composites”, *Acta Metallurgica et Materialia*, 40 (3): 427 – 441, 1992.
- [25] Mehmet Sarikanat, Yoldas Seki, Kutlay Sever, Cenk Durmuskahya , “Determination of properties of *Althaea officinalis* L. (Marshmallow) fibres as a potential plant fibre in polymeric composite materials”, *Composites: Part B*, 57: 180–186, 2014.
- [26] U.C. Jindal, Atish Mozumder, “ *Material Science and Metallurgy*”, Pearson education, third edition, New Delhi, India, 2013, pp. 332-333, ISBN 978-81-317-5911-0.
- [27] Alsaeed T., Yousif B.F. , Ku H., “The potential of using date palm fibres as reinforcement for polymeric composites” , *Materials and Design*, 43: 177-184, 2013.

## AUTHORS

**First author-** Neeraj Dubey, Ph.D. scholar Department of mechanical engineering, MANIT, Bhopal, 462051, MP, India E-mail: [dubey\\_neeraj2576@yahoo.co.in](mailto:dubey_neeraj2576@yahoo.co.in)

**Second author-**Dr. Geeta Agnihotri, Post doc.  
Department of mechanical engineering  
MANIT, Bhopal, 462051, MP, India  
E-mail: [dr.gagnihotri@gmail.com](mailto:dr.gagnihotri@gmail.com)

**Corresponding author-** Neeraj Dubey, Mechanical Engineering Department, MANIT, Bhopal, MP, India.  
E-mail: [dubey\\_neeraj2576@yahoo.co.in](mailto:dubey_neeraj2576@yahoo.co.in)  
Mobile: +919329286837

# Perceived Factors Affect Female Undergraduates' Attitudes toward Entrepreneurship Development

(Comparison Public and Private Universities in Ethiopia)

Chalchissa Amentie \*, Abdissa Gurmessa \*\*, Emmet Negash \*

\*MBA, department of Management, Jimma University Jimma, Ethiopia

\*\* MSc, department of Statistics, Jimma University Jimma, Ethiopia

**Abstract-** Female entrepreneurship is considered an important tool in enabling female empowerment and emancipation. The main objective of this article is to investigate perceived factors affect female undergraduates' attitudes toward entrepreneurship development (comparison public and private universities in Ethiopia)

For this study cross-sectional, descriptive and inferential designs study were used in the study. In the study both primary and secondary data were used. Pertaining to data analysis the researchers had used both qualitative and quantitative data analysis techniques mainly descriptive analysis using percentages, tables and graphs deployed. While for inferential statistics like distribution based analysis for nominal data type, chi-square, and multi-regression were used to test the statistically significant difference (independency) of variables, impacts of independent variables on dependent variable.

As per output of this finding there were different barriers those affects female undergraduates for not entering into entrepreneurship. The major barriers expected were, the responsibility of running a business too difficult, lack of a ability to know how to access business information, difficult to obtain the finance necessary and lack of a good business idea as an inhibitor to entrepreneurship, worry lack of experience needed to run a business and lack of the business skills required to run their own business.

Therefore, in order to change their worries from different barriers, entrepreneurship subject and training on entrepreneurs' successful characteristics are highly needed.

**Index Terms-** Female entrepreneurship, undergraduate students, attitude, Ethiopian Public and Private Universities

## I. INTRODUCTION

Female entrepreneurship is considered an important tool in enabling female empowerment and emancipation. It has been suggested by Weeks (2007) that women-led businesses can make a significant contribution to the economy. Allen, Langowitz, Elam and Dean (2007) further substantiated the importance of female entrepreneurial activity on economic development, finding investment in female entrepreneurship an important way for a country to exponentially increase the impact of new venture creation. Furthermore, they noted women are more inclined to share the benefits gained through entrepreneurship with members of their family and the wider community.

A national survey conducted by the Ethiopian Welfare Monitoring Unit (2002) shows, although women entrepreneurs contribute significantly to the national economy in terms of job creation, skills development and the alleviation of abject poverty among men and women alike, the literature clearly explains that small businesses and enterprises operated by women entrepreneurs are not being provided with adequate strategic support in terms of policy, access to finance, tax assessment, skills development and managerial training, technological transfer and infrastructural development (Berhanu, Abraham & Van der Berg, 2007). Although MSMEs operated by women cater for the poorest of the poor and make a sizeable contribution to the national economy, the level of support and recognition given to them has been minimal historically (Mogues, 2004). Businesses and enterprises operated by women contribute for economic dynamism, diversification, productivity, competition, innovation and economic empowerment of the poorest of the poor.

Self-efficacy is one of the main motivations of entrepreneur as it creates job satisfaction. Job satisfaction, in turn, is considered as an attitude toward one's job (Brief, 1998; Weiss, 2002). In the case of entrepreneurs, they do not have jobs in the traditional sense. Nevertheless, they indeed have jobs or tasks when they start and run a new business (Brief, 1998; Weiss, 2002, Bird, 2002 cited in Edgar and Marc, 2010).

According to a survey conducted in the Gullele sub-city of Addis Ababa illustrate, women in the cluster area estimated 39% were self-workers while men constitute the remaining 61% were self-workers (HK Hailu, 2010,P.53). Furthermore, as different past researches' report in Ethiopia shows, the majority of women had little education and find employment in the lower sections of the formal employment market. For example, in 1999/00 there were only 30.75% of women in the Civil Sector ('Shadow Report' 2003, p. 14) among which the majority, 98.2%, was concentrated in low status and low paying jobs (Aster *et al* 2002, p. 69). The level of unemployment is higher for women than for men among any section of society. In 1998, the Bureau for Labour and Social Affairs estimated the percentage of female unemployed at 58.6 and for males 41.4 in Addis Ababa (Alemnesh 2001, p. 97). According to age group, the unemployment level is higher among women than men in the age group 15-19 years with 16.8 % for women and 6.4% for males. This percentage increases slightly among the age group 20-24 with 17.8% of women and 7.4 % of males (Teshome 2004, p. 27 cited in Indrawatie, 2011).

The Shadow Report, which was compiled by the Ethiopian Women's Lawyers Association and the Network of Ethiopian Women Associations on the platform for action of the Beijing +10 Conference, revealed that the majority of Ethiopian women are employed in the informal sector (64.93%) ('Shadow Report' 2003, p. 14). This includes petty trade, handicrafts, selling food items, vegetables, locally produced drinks, domestic services, charcoal, firewood, second-hand clothes and so on ('Shadow Report' 2003, p. 14, Aster *et al* 2002, p. 70, Alemnesh 2001, p. 98 cite in Indrawatie, 2011, pp.170-171). The dominance of women in this sector illustrates the many factors leading to this. Such as; characteristics of the female entrepreneur, family background, personal & work experience, role models, the nature of female entrepreneurship, female barriers to entrepreneurship, educational influences on female entrepreneurship.

Additionally, as the result of study on women entrepreneurship in micro, small and medium enterprises was shown, the majority of businesses that failed were operated by women (78%). Businesses that failed were characterized by inability in obtaining loans from formal money lending institutions such as commercial banks, inability to convert part of profit back into investment, poor managerial skills, shortage of technical skills, and low level of education. Businesses operated by women were 2.52 times more likely to fail in comparison with businesses operated by men (Eshetu and Zeleke, 2008, p.1).

The current research has been undertaken to examine female undergraduates' attitudes towards and perceptions of entrepreneurship. This is necessary in order to obtain more knowledge and a better understanding of why so few female undergraduates consider entrepreneurship as a career and majority of businesses that failed were operated by women. This is important as the topic of female entrepreneurship and in particular female undergraduates and their views on entrepreneurship is a seriously neglected and under developed research area. An examination of literature shows there is little known about their needs, motivations and reservations concerning business ownership. The reason why final year female undergraduates are chosen for the current study is because they are at a period in their career development where they are considering different career routes and are therefore, a potential source of future female entrepreneurs.

## II. LITERATURE REVIEW

### 2.1 Definition of Entrepreneurship

It is important to start off with a discussion on the definition of entrepreneurship to ascertain what we mean by this concept. Singh and Belwal (2008:1) quote Desai (1999) to describe the roots of the word entrepreneur. They state "The word *entrepreneur* is derived from the French verb *entreprendre* that means *to undertake*". We can define an entrepreneur as ".....One who undertakes a commercial enterprise and who is an organizational creator and innovator" (Gartner, 1990; Gartner *et al.*, 2004, Mordi *et al.* 2010 cited in Muhammad and Amber, 2012).

Dzisi (2008: 3-4) gives the definition of entrepreneurship from the economic point of view, quoting the definition given by Schumpeter and Kirzner. "Schumpeter (1934) described the

entrepreneur as the innovator who introduces something new into an economy.

" and "...Kirzner (1997 – authors' own addition) stressed the fact that the entrepreneur is the decision maker in a particular cultural context, who commands a range of behaviours that exploit these opportunities".

Entrepreneurship is recognised both nationally and internationally as a key driver of growth (Fitzsimons and O'Gorman, 2003; Commission of the European Communities, 2004), with future prosperity depending on the creation of indigenous businesses (Orhan and Scott, 2001). Martin and Laing (1998) believed that a country's future economic development is dependent upon increasing its growing entrepreneurial talent. Morrison (1998) agreed with this, proposing that the successful entrepreneur is the "first among equals in the process of wealth creation" (Morrison, 1998, p.177).

It is difficult to get agreement among researchers and writers as to who exactly are these entrepreneurs (Carson, Cromie, McGowan and Hill, 1995). They have been described as the *new heroes* of our society (Donckels and Meittinen, 1990), who possess characteristics, which are highly prized in a culture (Hofstede, 1991). Garavan, O'Conneide, Fleming, McCarthy and Downey (1997) and Inman (2000) went back to the word entrepreneur to find a definition, citing an Irish economist, Cantillon (1755) who identified the entrepreneur as a pivotal figure in the economy, a risk taker, taking chances and facing uncertainty thus defining entrepreneurship as self-employment of any sort. Schumpeter (1934) expanded on this concept by introducing innovation as a determinant to entrepreneurship saying that entrepreneurs are people who introduce new combinations of factors of production, notably labour and capital. Therefore it can be deduced from the literature that entrepreneurs are clearly self-reliant people and their ambition is undoubtedly to create a business of their own (Johannison, 1990). Morrison, Rimmington and Williams (1999) came to the general conclusion that there are as many definitions of an entrepreneur as there are entrepreneurs.

### 2.2 Female entrepreneurship

It has been suggested by Weeks (2007) that women-led businesses can make a significant contribution to the economy. US statistics have shown that over the last twenty years women-owned businesses have grown at a rate of nearly two to one of other businesses and, interestingly, have made more of a significant impact on employment figures and revenue intake than is actually suggested by these figures (Centre for Women's Business Research, 2007). Allen, Langowitz, Elam and Dean (2007) further substantiated the importance of female entrepreneurial activity on economic development, finding investment in female entrepreneurship an important way for a country to exponentially increase the impact of new venture creation. Furthermore, they noted women are more inclined to share the benefits gained through entrepreneurship with members of their family and the wider community.

However, in Ethiopia the economy has yet to achieve substantial benefit from women led businesses as, in comparison with other countries, the level of female entrepreneurship is particularly low; for example in Portugal, Austria, and France female entrepreneurship can account for 41% of all new start-



up's (Henry and Kennedy, 2003; Gender Equality Unit, 2003; Fitzsimons *et al*, 2003; Fitzsimons and O'Gorman, 2004).

### **2.3 Obstacles to female entrepreneurship**

Welter (2004) has indicated that the participation of women in entrepreneurship has been hindered by the value that society places on women in employment, believing that as a result of past social norms women are still being stereotyped according to their gender thus limiting opportunities and creating occupational segregation.

Hisrich *et al* (1984) also acknowledged the difficulties that woman face when starting a business stating that the risk and effort entailed in starting a business from scratch is perhaps even greater for a woman entering a male dominated arena. Carter *et al* (2007) suggested that women lack finance and capital assets during the start-up period and argued that one of the key debates within female entrepreneurial research is how these barriers at the start-up stage affect the long-term business performance of women business owners.

#### **2.3.1 Confidence issues**

Lack of confidence can be a major problem in the area of female new venture creation (Minnitti *et al*, 2004; Chowdhury and Endres, 2005). Brindley (2005) agreed lack of confidence can have a negative effect on women entering into entrepreneurship. However, she believed that as a woman's confidence grows, her fear of risk diminishes.

Still *et al* (2000) specifically found women were less confident than men in matters relating to the management of staff, with lack of information and training being considered to be the principal reasons why women expressed less confidence in these areas. The subject of confidence is of significant interest to this research as it could have a crucial impact on the female undergraduate and her consideration of entrepreneurship as a career.

#### **2.3.2 Educational factors**

The female entrepreneur has a high level of education with some studies indicating that she often reaches a higher educational standard than her male counterpart (Madsen *et al*, 2003).

Brush *et al* (1991) recognised the importance of subject choice in enhancing the success of a female led business venture. Watkins *et al* (1984) believed subject choice is what differentiates between the male and female entrepreneur. Menzie *et al* (2003) and Madsen *et al* (2003) also recognized this difference in subject choice finding women were less inclined to study science and computer subjects and were more likely to major in health and natural science.

Consequently, a woman, due to her lack of business training especially in the areas of engineering and science is at an immediate disadvantage to entering traditionally male dominated areas such as construction and science (Hisrich *et al*, 1984).

### **2.4 Education and entrepreneurship**

Matthews *et al* (1995) acknowledged the significance of education and the part it plays in entrepreneurial activity, stating that it is critical to attract the young and educated to entrepreneurship, especially as current industrial trends are

towards a knowledge-based environment (Henderson and Robertson 2000; Postigo, Lacobucci, and Tamborini, 2006).

Carter *et al* (1999) and Gibb (1996) agreed with the importance of education to entrepreneurship, believing that ambitious, educated, young people can be equally encouraged into new venture creation as opposed to a large organisation, especially as the long-term supply of well educated and qualified entrepreneurs is essential to a strong modern society (Scott *et al*, 1988).

Therefore, it is of interest to note that Fitzsimons *et al* (2007) found a direct correlation between education and entrepreneurship finding entrepreneurial activity highest amongst those with a third level qualification. However, Wang and Wong (2004) in contrast suggested that education might be a deterrent to entrepreneurship as honour students show less interest in starting their own business, speculating that a longer time spent in education assimilating more business knowledge does not necessarily lead to higher interest in entrepreneurship.

#### **2.4.1 Entrepreneurship as a career choice**

Without doubt the choice of career for the undergraduate can be a complex and difficult process, with this decision-making process becoming even more intricate when the career path chosen is that of starting your own business (Nabi *et al*, 2006).

This can lead to entrepreneurship not readily being considered as a career choice (Henderson *et al*, 2000). Despite this, Wang *et al* (2004) acknowledged that undergraduates show a high level of interest in entrepreneurship, as a career.

#### **2.4.2 Entrepreneurial traits**

Louw, Van Eeden, and Bosch (2003) claim the age of the undergraduate plays a significant role in how students perceive their own entrepreneurial qualities finding the older the undergraduate the higher they assessed their level of entrepreneurial traits. Eeden Van, Louw and Venter (2005), while recognising the importance of entrepreneurial traits, also believed that these traits can be acquired through education, life experience and the entrepreneurial process. Interestingly, Scott *et al* (1988) noted undergraduate students who came from an entrepreneurial family background were more likely to believe they had entrepreneurial characteristics than students that did not come from an entrepreneurial family.

#### **2.4.3 Perceived barriers**

Financial risk is considered a major barrier to starting your own business with over fifty percent of university students in a study conducted by Robertson *et al* (2003) stating it as a problem. However, they claimed it was not fear of failure as in social embarrassment but the need for security, with many respondents citing having to pay back a student loan as a difficulty. Goodbody (2002) found fear of failure along with bankruptcy, the hard work involved, a small Irish market, difficulties accessing finance and lack of business information as undergraduate's main barriers to starting a business. Wang *et al* (2004) agreed with the fear of failure but added inadequate preparation and insufficient business knowledge to the list of perceived barriers. Lack of a business idea is also perceived as a barrier throughout literature on student entrepreneurship (Carter *et al*, 1999; Klapper, 2004), with Robertson *et al* (2003) finding

twenty-two percent of students citing the lack of a business idea as a reason for not starting a business.

Interestingly, Oakey et al (2002) noted that if a network of support systems were put in place to assist when starting a business, the undergraduates that had previously dismissed the idea of entrepreneurship as a career said they would reconsider entrepreneurship as a career option.

**2.5.1 Subject choice**

Hagen et al (1989) and Minniti et al, (2004) suggested the educational system as well as the social environment should encourage more women to study engineering, science, technical or business related subjects. This deficiency of women taking technical subjects is given an Irish perspective by Goodbody (2002) who noted the lack of female students pursuing science, engineering and technology qualifications, citing these subject choices as having particular importance because they often lead to entrepreneurial activity. However, Madsen et al (2003) noted in a Danish study that despite an active campaign to encourage female students to undertake technical subjects this has not yet been reflected in an increase of females entering into entrepreneurship in the high-tech sector.

**III. SAMPLING METHOD (TECHNIQUE) AND SAMPLING SIZE**

In public: Jimma University, Addis Ababa University, and Wollega University while among private universities; Rift-Valley Universities at wollega and Adama Campus, Unity University at AA campus and New generation at Nekemte campus were taken as a sample of representative by convenience method with consideration of location of both private and public universities those found in the same cities to reduce cost. And respondents

were taken from selected Universities by disproportional method because of the size of students found in them are vary as follow.

**Table 3.1 Of sample size from each stratum**

Colleges and Universities	Number of students
Addis Abeba University	100
Jimma University	150
Wollega University	100
Rift Valley Adema & Nekemte campus	120
Unity campus	80
New generation Nekemte campus	80
Total	630

Hence, to identify the necessary information, 630 samples were proposed to be selected by simple random from all selected sample Universities and colleges.

**IV. DATA ANALYSIS**

**4.1 The career immediate intentions of female students after completion of present degree course**

Only 9% of the combined group of respondents expressed a wish to work in a small or medium company (SME) this could be perceived as a negative factor towards the encouragement of entrepreneurial activity as working in an SME has been found to be an influencing factor towards the encouragement of entrepreneurship (Oakey et al,2002). The immediate intentions of the respondents after the completion of their degree course can be seen in table.

**Table 4. 1. Career immediate intentions of female students**

Question	Public U		Private UC	
	Frequency	%	Frequency	%
Continue further with your education?	262	86.2	168	77.8
Work with a company and obtain a professional qualification?	226	76.4	152	71
Work for the public sector e.g. civil service?	150	56	109	47
Work with a small or medium company?	120	43.5	106	49
Work with a large company?	236	82	150	71
Start your own business?	216	74	156	72
Continue with a business that you have already started?	136	51	100	50

As table 4.1 shows the immediate intentions female students after the completion of their degree course were as follow. 86.2% of female from public Universities and 77.8% of female from private Universities were want to continue further with their education, 76.4% of female from public Universities and 71% of female from private Universities' want to work with in a company and obtain a professional qualification, 82% of female from public Universities and 71% want work within a large company while 74 % of female from public Universities and 72% want to start their own business.

As this finding present that the student who expressed their wish to start their own small business in public Universities are no more different from female students those private Universities College want to start their own small business.

Relatively, less of the combined group of respondents (46%) expressed a wish to work in a small or medium company (SME) this could be perceived as a negative factor towards the encouragement of entrepreneurial activity as working in an SME ( Oakey et al, 2002).

#### 4.2 Entrepreneurship as Attractive Career Option

Dyer (1994) found working for an entrepreneur or knowing an entrepreneur had a positive impact on entrepreneurial career choice. Without doubt the choice of career for the undergraduate can be a complex and difficult process, with this decision-making process becoming even more complicated when the career path chosen is that of starting your own business (Nabi *et al*, 2006).

This can lead to entrepreneurship not readily being considered as a career choice (Henderson *et al*, 2000). Despite this, Wang *et al* (2004) acknowledged that undergraduates show a high level of interest in entrepreneurship, as a career.

**Table 4.2 Entrepreneurship choice as career option**

Is entrepreneurship is an attractive career option		Types of university		Total
		public	private	
strongly agree	Count	116	74	190
	%	34.9	33.3	34.3
agree	Count	172	116	288
	%	51.8	52.3	52.0
neutral	Count	30	20	50
	%	9.0	9.0	9.0
disagree	Count	14	12	26
	%	4.2	5.4	4.7
Total	Count	332	222	554
	%	100.0	100.0	100.0

$X^2 = 0.506, N=554, df=3, p= 0.918$

As the above table indicates, 86.7% of sampled female students from public Universities and 85.6% of them from private universities were positively accepted as entrepreneurship is an attractive career option.

Similarly, as the result of chi-square test indicated entrepreneurship as an attractive career and there was no significant difference found ( $X^2 = 0.506, df = 3, p = .09918$ ) in the view of the female graduate batch students from public universities and private Universities. The students those are from public Universities are much more likely to consider entrepreneurship an attractive career.

#### 4.3 Students' attitudes towards and perceptions of entrepreneurship

This section shows persons' attitude toward and perceptions of entrepreneurship (self-employment). Empirical support for the relational link between attitudes and perceptions is strong (Ajzen, 1985); and previous studies have confirmed the appropriateness of the application of behavioural perceptions models in entrepreneurship research (Krueger and Carsrud, 1993; Davidsson, 1995; Krueger *et al.*, 2000).

**Table 4.3 Female students' attitude toward and perceptions of entrepreneurship (self-employment)**

Questions	Responses	Freq	%	Cumulative Percent
You require special characteristics to start your own business	strongly disagree	62	11.5	11.5
	disagree	156	28.9	40.4
	neutral	54	10.0	50.4
	agree	186	34.4	84.8
	strongly agree	82	15.2	100.0
	Total	540	100.0	
Female business owners are taken less seriously than male business owners	strongly disagree	150	27.7	27.7
	disagree	218	40.2	67.9
	neutral	54	10.0	77.9
	agree	92	17.0	94.8
	strongly agree	28	5.2	100.0
	Total	542	100.0	
Women have the same confidence as men to start abusiness	strongly disagree	56	10.0	10.3
	disagree	148	26.3	36.3
	neutral	48	8.5	44.8
	agree	130	23.1	67.9
	strongly agree	160	28.5	96.4
	Total	542	96.4	100.0

Women do not like taking risks	strongly disagree	154	29.2	29.2
	disagree	184	34.8	64.0
	neutral	46	8.7	72.7
	agree	120	22.7	95.5
	strongly agree	24	4.5	100.0
	Total	528	100.	
A women starts a business to combine career and family responsibility	strongly disagree	56	10.4	10.4
	disagree	100	18.6	29.0
	neutral	98	18.2	47.2
	agree	214	39.8	87.0
	strongly agree	70	13.0	100.0
	Total	538	100.0	
It is more difficult for women than man to obtain finance	strongly disagree	126	23.9	23.9
	disagree	128	24.2	48.1
	neutral	74	14.0	62.1
	agree	112	21.2	83.3
	strongly agree	88	16.7	100.0
	Total	528	100.0	
you need to work extra hard when you have your own business	strongly disagree	66	12.3	12.3
	disagree	112	20.9	33.2
	neutral	56	10.4	43.7
	agree	216	40.3	84.0
	strongly agree	86	16.0	100.0
	Total	536	100.0	
Societies in general encourages women to start their own business	strongly disagree	76	14.1	14.1
	disagree	160	29.7	43.9
	neutral	80	14.9	58.7
	agree	152	28.3	87.0
	strongly agree	70	13.0	100.0
	Total	538	100.0	
The media encourage women	strongly disagree	40	7.4	7.4
	disagree	90	16.7	24.1
	neutral	46	8.5	32.6
	agree	254	47.0	79.6
	strongly agree	110	20.4	100.0
	Total	540	100.0	

For question about female students' attitude toward and perceptions of entrepreneurship (self-employment) respondents were expressed their attitude toward and perceptions.

The above table depicts that 49.6% of sample respondents responded that female students require special characteristics or traits to start their own business even though 40.4% replied no need special characteristics and 10% were neutral.

This shows as the majority of respondents perceived that one required special characteristics or traits if one want to start one's own business, which is in agreement with (Postigo *et al.*, 2006 and Eileen, 2008) whose research found entrepreneurs are seen as people with specific attributes.

The female business owners are taken less seriously than male business owners were also seen as a basic requirement when entering entrepreneurship with 67.9% of the students disagreed with the suggestion that female business owners are taken less seriously than male counterpart which contradict to the findings of Lim, Smith and Bottomley (2003) who found there was a 50/50 split between women business owners on the issue of women not being taken seriously when conducting business.

It was also found in this present study that almost the respondents agreed that women have the same confidence as

men. And when it comes to starting a business just more than half of these students (55.2%) agreed with the suggestion that women have the same confidence as men to start a business while only 36.3% disagreed.

There was a definite disagreement when it came to the question of risk, (64.0%) of the respondents disagreed the idea that women do not like taking risks. It is supported with the finding of Eileen (2008) that stated as over three quarters of the respondents rejected the idea that women do not like taking risks. But it is contrast to the finding in which over two thirds of the students who do not want to start their own business stated fear of business failure, running into debt and lack of a secure income as the reasons for not entering into entrepreneurship.

Almost half of respondents (48.1%) disagreed with the statement; it is more difficult for women than a man to obtain finance. While 38.8% of the students' believed that as it would be too difficult for women than men to obtain the finance necessary to start a business and see this as an inhibitor to starting a business

However, 43.9% of the respondents disagreed that society in general encourages women to start their own business while 42% of them were agreed with this idea. This similar with the finding

of McClelland (2003) believed there is a lack of support from society and sees this as a barrier to female entrepreneurship. In addition, 67.4 % of the respondents in the current study believe the media encourages women into entrepreneurship by giving positive coverage of successful women who own their own businesses while only 24.1 % of the them in the current study did not believe the with the idea.

Though there are differences between the private and public university students concerning entrepreneurship and its perceived viability as a career option at an individual level, these differences are not so obvious when it comes to the attitudes expressed towards entrepreneurship in general. Interestingly there is a perception among the combined group of students that one requires special characteristics or traits and needs to be very determined to run a successful business. This may lead some students to selfselect themselves out of entrepreneurship. The support of media encourages women is believed to be extremely important when starting a business especially as there is a perception that society in general does not encourage women into entrepreneurship.

Generally, from this research it is possible to conclude as those students with a strong favorable attitude toward self-employment would be more likely to develop strong self-employment perception. Previous research (Ajzen, 1987; Krueger and Carsrud, 1993) confirms different factors either moderate the intentions-behavior relationship, or indirectly affect perceptions through attitudes, beliefs and perceptions.

For furthermore study, some interview were held with some students. As expressed by some interviewees some of them want to start their own small business because of they want: flexibility, gain respect from others, indepeny, to generate their own income while others have raised reason they want to start their

own business were because of they expect as there is no job opportunity by government, they will not satisfied working with in either government office or private company.

In addition, one of female student stated choosing entrepreneurship is because of challenge, independence (opportunity) and frustration at work (necessity) I have heard and observed from my parents. *“My families have been working in private organization for about 17 years and I was looking forward to for long while they were doing. They were very frustrated and their work was not so challenging anymore and besides they had little autonomy. They used to vent their anger at home. They realized that they were not being fair to their family or to me. Because of these I decided that I should start something of my own and knew that I will do it. It is true that I do not have much time to myself as they had before but I am much happier and I will be now my own boss”.*

Generally, the result of this study leads to believe that women often choose entrepreneurship not only because they expect the idea to have greater return. And they want to start their own business seemed a good choice as it also enabled them to be more independent

#### 4.4 Perceived barriers of female undergraduates for not entering into entrepreneurship

Female entrepreneurs encounter several issues that further exacerbate the barriers between them and their successful entrepreneurial venture. These constraints may come from their personality, immediate family, or from the environment in which they exist and the societal expectations and perceptions of the people around them.

The following table summarizes the response of female undergraduates’ on barriers not entering into entrepreneurship

**Table 4.4 barriers of female undergraduates for not entering into entrepreneurship**

<i>I do not want to start my own business because:</i>		Freq	%	Cumulative Percent
The responsibility of running a business too difficult	strongly disagree	112	21.5	21.5
	disagree	172	33.1	54.6
	neutral	72	13.8	68.5
	agree	130	25.0	93.5
	strongly agree	34	6.5	100.0
	Total	520	100.0	
I do not know how to access business information	strongly disagree	68	13.4	13.4
	disagree	156	30.7	44.1
	neutral	64	12.6	56.7
	agree	152	29.9	86.6
	strongly agree	68	13.4	100.0
	Total	508	100.0	
it would be too difficult to obtain the finance necessary	strongly disagree	88	17.1	17.1
	disagree	134	26.1	43.2
	neutral	82	16.0	59.1
	agree	134	26.1	85.2
	strongly agree	76	14.8	100.0
	Total	514	100.0	
Afraid of running into debt	strongly disagree	90	17.4	17.4
	disagree	160	30.9	48.3
	neutral	74	14.3	62.5
	agree	134	25.9	88.4



	strongly agree	60	11.6	100.0
	Total	518	100.0	
	Total	518	100.0	
I would be afraid that my business would fail	strongly disagree	90	17.4	17.4
	disagree	160	30.9	48.3
	neutral	74	14.3	62.5
	agree	134	25.9	88.4
	strongly agree	60	11.6	100.0
	Total	518	100.0	
I don't have a good business idea.	strongly disagree	94	18.2	18.2
	disagree	196	38.0	56.2
	neutral	64	12.4	68.6
	agree	126	24.4	93.0
	strongly agree	36	7.0	100.0
	Total	516	100.0	
Lack of experience needed to run a business	strongly disagree	80	15.5	15.5
	disagree	122	23.6	39.1
	neutral	58	11.2	50.4
	agree	166	32.2	82.6
	strongly agree	88	17.1	99.6
	Total	516	100.0	
Lack of the business skills required to run a business.	strongly disagree	90	17.6	17.6
	disagree	130	25.5	43.1
	neutral	60	11.8	54.9
	agree	180	35.3	90.2
	strongly agree	50	9.8	100.0
	Total	510	100.0	
I would be afraid of the lack of a secure income	strongly disagree	78	15.0	15.0
	disagree	170	32.7	47.7
	neutral	92	17.7	65.4
	agree	152	29.2	94.6
	strongly agree	26	5.0	99.6
	Total	520	100.0	
The education area I studied is not suitable to start a business in	strongly disagree	110	21.3	21.3
	disagree	208	40.3	61.6
	neutral	64	12.4	74.0
	agree	94	18.2	92.2
	strongly agree	38	7.4	99.6
	Total	516	100.0	
Entrepreneurship does not have the same status or respect as others careers	strongly disagree	102	19.5	19.5
	disagree	192	36.8	56.3
	neutral	78	14.9	71.3
	agree	108	20.7	92.0
	strongly agree	40	7.7	99.6
	Total	522	100.0	
I had family commitment	strongly disagree	66	12.6	12.6
	disagree	168	32.1	44.7
	neutral	120	22.9	67.6
	agree	134	25.6	93.1
	strongly agree	34	6.5	99.6
	Total	524	100.0	
	Total	520	100.0	
There is too much red tape e.g. legal and employment Regulations required when running a business.	strongly disagree	54	10.3	10.3
	disagree	134	25.7	36.0
	neutral	94	18.0	54.0
	agree	174	33.3	87.4
	strongly agree	66	12.6	100.0
	Total	522	100.0	
I do not have the personal skill and competencies	strongly disagree	88	16.8	16.8

necessary	disagree	200	38.2	55.0
	neutral	58	11.1	66.0
	agree	152	29.0	95.0
	strongly agree	26	5.0	100.0
	Total	524	100.0	

In present study in order to identify the major barriers of female undergraduates for not entering into entrepreneurship different question were asked female students. Accordingly, question whether the responsibilities of running a business too difficult to entering into entrepreneurship were asked. 31.5% of respondents were agreed as the responsibility of running a business too difficult one of a barrier starts their small business.

It was also found in this current study that 43.3% of the respondents agreed that a lack of a ability to know how to access business information is the main reason they would not enter into entrepreneurship. In addition, 40.9% of respondents also cited as too difficult to obtain the finance necessary are a barrier to starting their own business. This finding is in agreement with Hazlett, Henderson, Hill and Leitch (2005) who found it a major barrier to start up. Of the remaining students 16% were unsure of the difficulty to obtain finance and 43.2% disagreed with it being difficult.

While 37.5% of selected students thought as the afraid of running into debt the pressure start their own business. 43.8% of the students saw a lack of a good business idea as an inhibitor to entrepreneurship. This is in agreement with (Scott and Twomey 1988 and

Eileen, 2008) who noted that students that had relevant work experience were more inclined to have a business idea than students that did not have work experience and that a good business idea is a main trigger factor in the encouragement to enter entrepreneurship.

Many of the respondents (49.3%) also believed lack of experience needed to run a business barrier of entrepreneurship with 45.1% of the students agreeing they do not have the business skills required to run their own business. This lack of business skills was also found by Robertson, Collins, Medeira, and Slater (2003) as a reason for not starting a business.

Some of the respondents (31.2%) also believed entrepreneurship would be too difficult if they had family commitments. Furthermore, on the entrepreneurship does not have the same status or respect as others careers to run a business is also seen as a problem with 27.7 % of the students agreeing they do not have the business skills required to run their own business while 56.3 % of them disagree that entrepreneurship does not have the same status and respect as other careers. Business external influences do not appear to have a major impact on the discouragement of entrepreneurship with over 46% of the students considering “too much red tape” a reason for not entering entrepreneurship and only 36% disagreeing that the ethiopia there is too much red tape e.g. legal and employment and regulations required when running a business in market is too small and therefore not having enough potential for starting a business.

## V. CONCLUSION

- Based on the finding of the study the following recommendations were forwarded:
- Majority of female students in both public Universities and private university college were expressed their intention as they need entrepreneurial education to start a business.
- Since it is very important for all students if entrepreneurial education to be included in their course education as one course because it creates positive attitude towards entrepreneurship and as they start their own business.
- Majority of respondents were positively accepted as entrepreneurship is an attractive career option. And the students who expressed their wish to start their own small business in public Universities are no more different from female students those private Universities College want to start their own small business. However, relatively, less of the combined group of respondents expressed a wish to work in a small or medium company (SME) this could be perceived as a negative factor towards the encouragement of entrepreneurial activity as working in an SME. Therefore, it is better if different training given to students to more encourage them as they start their own small business.
- There are no so obvious differences between the private and public university students when it comes to the attitudes expressed towards entrepreneurship in general. Interestingly there is a perception among the combined group of students that one requires special characteristics or traits and needs to be very determined to run a successful business. This may lead some students to self-select themselves out of entrepreneurship. The support of media encourages women is believed to be extremely important when starting a business especially as there is a perception that society in general does not encourage women into entrepreneurship. Generally, students with a strong favorable attitude toward self-employment would be more likely to develop strong self-employment perception. Therefore, different factors like media should used either to moderate the intentions-behavior relationship, or indirectly affect perceptions through attitudes, beliefs and perceptions of female students towards entrepreneurship.
- Different female students were motivated by different factors to start their own business. Such as, to gaining respect from others, assuming to enable to get better work / life balance, able to use their business idea and business skills, entrepreneurship would allow them to work in the area of their own choice were seen as an essential reason for starting their own business , enable them to pick their own working time, making a lot of money is also one of the main reasons they want to start their business and choosing entrepreneurship as a career it would give them flexibility to combine their career with their family life and self-

fulfillment. Generally, the motives for becoming an entrepreneur are not a clear cut situation but are rather a complex set of mixture of different factors. Therefore, it is better to motivate female students for starting their own small business, if training provided to them on both pull and push factors.

- Different barriers were raised by female undergraduates for not entering into entrepreneurship. The major barriers expected were, the responsibility of running a business too difficult, lack of a ability to know how to access business information, difficult to obtain the finance necessary and lack of a good business idea as an inhibitor to entrepreneurship, worry lack of experience needed to run a business and lack of the business skills required to run their own business.
- Therefore, in order to change their worries from different barriers, entrepreneurship subject and training on entrepreneurs' successful characteristics are highly needed. Because it is highlighted as a positive 'trigger event' to be an event that stimulates a change process and as influential to the relationship between both increase confidence of self-employment and perceived and self-employment intention. This means entrepreneurship education will reduces worries of different barriers however is not essential for the formation of self-employment intentions.

#### REFERENCES

- [1] Ajzen, I. (1991) The theory of planned behaviour. *Organisational Behavior and Human Decision Processes*, 50, 179-211.
- [2] Bird, B. (1988) Implementing entrepreneurial ideas: the case for intention, *Academy of Management Review*, 13, 3, 442-453.
- [3] Boyd, N.G. and Vozikis, G.S. (1994) The influence of self-efficacy on the development of entrepreneurial intentions and actions. *Entrepreneurship Theory and Practice*, 18, 4, 63-67.
- [4] Buttner, E., H and Moore, D., P., (1997) Women's Organizational Exodus to Entrepreneurship: Self-Reported Motivations and Correlates with Success. *Journal of Small Business Management*, 35 (1), 34-46.
- [5] Chen, C.C., Greene, P.G. and Crick, A. (1998) Does entrepreneurial self-efficacy distinguish entrepreneurs from managers? *Journal of Small Business Venturing*, 13, 4, 295-316.
- [6] Crant, J.M. (1996) The proactive personality scale as a predictor of entrepreneurial intentions, *Journal of Small Business Management*, 34, 3, 42-49.
- [7] Davidsson, P. (1995) Determinants of entrepreneurial intentions, Working Paper 1995: 1. Jonkoping: Jonkoping International Business School.
- [8] Douglas, E.J. and Shepherd, D.A. (2002) Self-employment as a Career Choice: Attitudes, Entrepreneurial Intentions, and Utility Maximization, *Entrepreneurship Theory and Practice*, 26, 3, pp.81-90.
- [9] Gasse, Y., Camion, C., Ghamgui, A. and Tremblay, M., (2006) Entrepreneurial Intentions: A Cross Cultural Study of University Students in three Countries. *Serie Electronic 2006 Document 2006-019*.
- [10] Available:<http://www5.fsa.ulaval.ca/sgc/recherche/publications/documentsdetravailparauteur/cache/bypass/pid/4213?appid> [Accessed on September 06/2014].
- [11] Katz, J. and Gartner, W. (1988) Properties of emerging organisations, *Academy of Management Review*, 13, 3, 429-441.
- [12] Kolvereid, L. (1992) Growth aspirations among Norwegian entrepreneurs, *Journal of Business Venturing*, 7, 209-222.
- [13] Kolvereid, L. and Isaksen, E. (2006) New business start-up and subsequent entry into self-employment. *Journal of Business Venturing*, 21, 866-885.
- [14] Krueger, N., and Brazeal, D. (1994) Entrepreneurial potential and potential entrepreneurs, *Entrepreneurship Theory and Practice*, 18, 3, 91-105.
- [15] Krueger, N. and Carsrud, A. (1993) Entrepreneurial intentions: Applying the theory of planned behaviour. *Entrepreneurship and Regional Development*, 5, 315-330.
- [16] Krueger, N., Reilly, M., and Carsrud, A. (2000) Competing models of entrepreneurial intentions. *Journal of Business Venturing*, 15, 5-6, 411-432.
- [17] Peterman, N.E. and Kennedy, J. (2003) Enterprise education: Influencing students' perceptions of entrepreneurship. *Entrepreneurship Theory and Practice*, 28, 2, 129-144.
- [18] Shapero, A. (1975) The displaced, uncomfortable entrepreneur, *Psychology Today*, 9, 83-133.
- [19] Dell McStay(2008).An investigation of undergraduate student self-employment intention and the impact of entrepreneurship education and previous entrepreneurial experience. Research report, PhD .Bond Universit,The Australia
- [20] Dzisi, S. (2008), "Entrepreneurial Activities of Indigenous African Women: A Case of Ghana", *Journal of Enterprising Communities: People and Places in the Global Economy*, Vol. 2, No. 3, pp. 254-264
- [21] Edgar I. and Marc B.(2010). *Journal of Competing Models of Entrepreneurial Intentions: The Influence of Entrepreneurial Self-efficacy and Attitudes*. Ghent University,
- [22] Eileen S.( 2008).An Exploration of Female Undergraduates' Attitudes Towards and Perceptions of Entrepreneurship, Margaret Tynan ,Centre for Entrepreneurship
- [23] Eshetu B. and Zeleke W.(2008) Women Entrepreneurship in Micro, Small and Medium Enterprises:The Case of Ethiopia ,*Journal of International Women's Studies Vol. 10 #2 November 2008*
- [24] GEM 2008, [Total Entrepreneurial Activity by Country by Gender: Global Entrepreneurship Monitor Executive Report]
- [25] [http://www.gemconsortium.org/download/1267867372921/GEM\\_Global\\_08.pdf](http://www.gemconsortium.org/download/1267867372921/GEM_Global_08.pdf) 10th Annual Report (accessed on 15February 2010)
- [26] Hazlett, S., A., Henderson, J., Hill. F. and Leich. C., (2005) Students' Understanding, Perceptions of and Attitudes Towards Entrepreneurship: A Preliminary Study. *Forum Promoting Female Entrepreneurship*. Dundalk Institute of Technology.
- [27] HK Hail (2010).Success Factors in Micro and Small Enterprises Cluster Development: Case of Gullele Handloom Clusters in Ethiopia .A Research Report MBA,University of South Africa
- [28] Indrawatie B. (2011).The Role of Educated/Intellectual Women in Ethiopia in the Process of Change and Transformation towards Gender Equality 1974-2005.research paper Msc. University of South Africa
- [29] Jamali, D. (2009), "Constraints and Opportunities Facing Women Entrepreneurs in Developing Countries: A Relational Perspective", *Gender in Management: An International Journal*, Vol. 24, No. 4, pp. 232-251
- [30] Muhammad A and, Dr. Amber G(2011) : Female Entrepreneurs – A Review of the Literature and Conceptual Framework :Institute of Business Administration (IBA), Karachi
- [31] National Bank of Ethiopia. (2004). Quarterly Bulletin of the National Bank of Ethiopia, No. 19(3), 23-29.
- [32] Negash, Z. & Kena, T. (2003). State, Growth and Dynamism of Micro and Small Enterprises in Mekele, Ethiopia. Report produced for the Department of Economics of Mekele University, Ethiopia. Mekele: Mekele University.
- [33] Muhammad U .and Amber G. (2011) Female Entrepreneurs – A Review of the Literature and Proposed Conceptual Framework .Female Entrepreneurs Proceedings of 2nd International Conference on Business Management (ISBN: 978-969-9368-06-6)
- [34] Weeks, J., (2007) How Multi-Lateral Organisations are Supporting Women's Enterprise Around the Globe. [online] Available:[http://www.womenable.com/userfiles/downloads/weeks\\_enterprising\\_women\\_feb2007.pdf](http://www.womenable.com/userfiles/downloads/weeks_enterprising_women_feb2007.pdf) [Accessed 24th January, 2013].
- [35] Welter, F., (2004) The Environment of Female Entrepreneurship in Germany. *Journal*
- [36] Wood and Bandura, A. (1982). Self-efficacy mechanism in human agency. *American Psychologist*, 37, 122-147.
- [37] Zhao, H., Hills, G.E., and Seibert, S. (2005) The mediating role of self-efficacy in the development of entrepreneurial intentions. *Journal of Applied Psychology*, 90, 6, 1265-1272.

AUTHORS

**First Author** – Chalchissa Amentie (MBA), department of Management, Jimma University Jimma, Ethiopia, email Chalchissa@yahoo.com

**Second Author** – Abdissa Gurmessa (MSc) department of Statistics, Jimma University Jimma, Ethiopia, email; abdoko006@yahoo.com

**Third Author** – Emnet Negash (MBA), department of Management, Jimma University Jimma, Ethiopia, email negashemnet089@gmail.com

# Duties Family in The Prevention of Acute Respiratory Infectious Disease (ARI) in Children in Society based on Leinenger Theory Approach

Nuzul Qur'aniati, S.Kep., Ns., M.Ng, Iqlima Dwi K, S.Kep., Ns., M.Kep, Aria Aulia N, S.Kep., Ns., M.Kep

Maternity and Child Nursing Department, Faculty of Nursing Universitas Airlangga Surabaya

**Abstract- Introduction:** Infectious diseases are the second highest cause of infant mortality in the world. In Indonesia acute respiratory infection (ARI) is one of infectious diseases which causes many deaths, especially in infants and toddlers. Efforts to overcome these, nurses are expected to have a role to perform five tasks assessment families with adopted culture. Understanding of the culture can be carried through nursing transcultural approach that explains awareness and appreciation of cultural differences. This study aims to describe the family experience in the implementation of tasks in the family health and disease prevention of infectious diseases due to lifestyle based on Leininger's theory. **Methodology:** This study used the method of qualitative with phenomenological study approach. In this study consist of six participants who met the inclusion criteria. Data were analyzed using Collaizi method. **Results:** The results obtained consist of five themes. Theme 1 is a familiar problem. Theme 2 is how to make decisions. Theme 3 is caring for a sick member. Theme 4 is modification of the physical environment and compliance. Theme 5 is the use of existing health facilities. **Discussion:** Family has implemented five family duties in the prevention of infectious diseases in children with relatively simple home treatment for prevention of transmission, utilizing the nearby health facilities such as health centers, doctors clinique, and hospitals beside utilizing alternative treatments such as massage and treatment to the traditional healer as the influence of cultural values Java. Application of their family duties largely influenced by economic conditions and lower-middle education and the influence of Javanese culture. The results of this study recommends that community empowerment in the prevention of infectious diseases in children with operational research methods is essential.

**Index Terms-** ARI in children, five family duties, transcultural nursing approach

## I. INTRODUCTION

Health development in the health ministry's strategic plan for 2010-2014 focuses on eight priorities, one of which is the control of infectious diseases and non-communicable diseases and followed with environmental sanitation (Ministry of Health of Indonesia, 2012). Infectious diseases and lifestyle diseases are the diseases that can be prevented, but the incidence of the disease remains high in the world, especially in developing countries.

Infectious diseases are a major cause of morbidity and mortality in infants and children that are especially common in developing countries, including Indonesia. In 2000, *the World Health Organitaios* (WHO) reported that infectious diseases are the second highest cause of infant mortality in the world where the *Proportional Mortality Rate* (PMR) Acute Respiratory Infections (ARIs) are 19% and 13% for diarrhea. Information on infectious diseases in 2013, Basic Health Research (called *Riskesdas*) report that period prevalence of ARI Indonesia (25.0%) is not much different from 2007 (25.5%). Characteristics of the population with the highest ARI occur in the age group 1-4 years (25.8%). By sex, did not differ between men and women. The disease is more experienced in population groups with the lowest quintile of the index and middle ownership down.

The family is becoming one of the focus of intervention in nursing as a family is an important resource in the provision of services for individuals and families that are proven to increase the effectiveness of treatment (Gillis and Davis in Friedman, Bowden and Jones, 2003). A family can function well if each provides motivation, freedom and to provide protection and security to achieve the potential for family members so that the family also has a duty of care for family members including recognizing health problems, making good decisions, able to provide an environment conducive to health maintenance and growth of individuals and families are able to use health facilities (Maglaya et. al, 2009).

Nurses have a role to start improving the health status and is expected to advocate for the needs of the community. To achieve this required a good assessment capability in determining the most obvious problems. Assesment that can be done is through the study of five tasks families with adopted culture. Understanding of the culture can be carried through in nursing transcultural approach that explains awareness and appreciation of cultural differences. This means that professional nurses have the knowledge and practice that are based on the concept of culture and to practice planning.

## II. MATERIALS AND METHODS

This study used the method of qualitative with phenomenological study approach. This study used the initial step in phenomenological research is to explore the direct descriptive phenomenology, analyze and describe the phenomenon of family on family duties in the prevention of infectious diseases in children in the community.



The population in this study were families with children who suffer from infectious diseases in the health center in August-September 2014. The sample in this study were six participants who meet the inclusion and exclusion criteria in recruitment. Participants in this study is a mother with a child suffering from infectious diseases, are willing to become participants by giving consent and signed a consent form. Although only amounted to six participants it is in line with the theory Polit and Hungler (1999) explains that in qualitative research the number of participants is determined by the saturation of the data, namely the participants reached a saturation point where no new information has been obtained and repeatability can be achieved. It is also appropriate that described Riemen (1986) in Creswell (1998) which states that the ideal number of participants in the qualitative study with phenomenological method consists of 3 to 10 people.

Collecting data in this study used the research instrument in the form of a structured interview based on the prevention of infectious diseases Leinenger theory developed by researchers using recorder and *field notes*.

Data validation is done by checking the correctness of the data based on the results recorded, performing a comparative analysis to ensure research results. Data analysis in this study used Collaizi method because this method provides the steps are simple, clear, and detailed. The process of transcription is done through (1) play the recording and writing the word-for-word into a computer file; (2) rechecking the results of the interview transcript to listen to the recording while reading the transcript; (3) Results of field notes in the form of non-verbal responses during the interview integrated accordance; (4) Researchers read the transcript repeatable results and determine the significant statements; (5) Keywords are identified through screening a statement-statements and keywords that have the same relative sense formulated in one category; (6) The same category are grouped into sub-themes that are more common. The theme of the grouping formed several sub-themes which implies equal. Prior to the study conducted by researchers has completed ethical clearance, and letter permit from health district officer and community health center itself.

### III. THE RESULTS

All participants in this study are housewives with range of age 25-40 years of age. All participants are Muslims. At the time of the interview participants was accompanied by his son. 4 out of 6 participants are living in the boarding family, with unhealthy environment, lots of birds and near the river.

Based on the results of the data analysis are resulted five themes that emerged from the content analysis performed.

#### **Theme 1: Know the problem**

This theme discusses the structure and contents of the perception of the family in caring for a child with ARI.

More than two third participants mentioned varies opinion related to the causes of disease such as exhaustion, contracted from other family members, the influence of weather, dust and unhealthy environment. In addition to the average participant also mentioned eating too much ice so his endurance down, eat snacks containong MSG, and unconscionus (called sawanan

Javanese) with a clown, a cat as the etiology of fever, cough and runny nose.

Almost the majority of participants said that children who are experience sick tend to be fussy, crying and asking carried on.

#### **Theme 2: Taking decisions**

Looking at the changes that occurs in the health status of family members, usually a family member who lives at home or who is given the responsibility to make a decision to save his family. Family also look after their family based on their personal experience or to treat his or her family member in his own way. In addition, the family also seek information from another family member, neighbor or coworker.

#### **Theme 3: Caring for a sick member**

Family will be responsible for looking after their member who is sick. Both the nuclear family and the extended family will provide the necessary care by family members. The family realized that ARI will often experienced by their children due to lack of immunity. At this stage, the family is able to care for sick family members, knowing the state of illness, treatment is needed, the existence of the necessary medical facilities.

Family describes the efforts made by the family if a family member is sick. Most of the family state that giving paracetamol, traditional medicine in the form of a mixture of ginger, lemon juice, a little salt, onion, and sratching with oil Telone (**called kerokkan**). Small families also mention compresses, giving antibiotics, and drinking water convulsions as alternative.

The results of the interview explains that the majority of funding sources of treatment comes from personal payment. Only one (1) person used prudential insurance. The average income of the participants are ranged in the range of 1.5 to 2 million rupiah.

#### **Theme 4 is Modification of the physical environment and fulfillment environmental conditions**

Family seeks to create a supportive environment for children who are sick. Efforts were mentioned by family associated with transmission is to use a mask, limitation to playig, always hand washing, separating cutlery, giving multivitamins, isolating from sick chidren to health children, do not drink ice.

#### **Theme 5: use of health facilities**

Families are able to use public resources in order to maintain health. Public perceptions of the health-illness closely related to the health seeking behavior showed that family still seeks to health care and alternative medicine to treat their family. Transportation used to to place health facilities are riding motorcycles, catching public transportation, and on foot depending on distance.

The results of the interview also mentioned that the participants have the expectation to health workers in order to polite, friendly and able to provide an explanation of the condition of the disease without being asked.

### IV. DISCUSSION

There are two basic functions of the family that are physical and psychosocial well-being needs. Physical well-being includes

the requirement for food, clothing, safety and physical health. Psychosocial well-being is being able to be a family when the basic framework structure or psychosocial growth and growing families who successfully underwent psychosocial well. Family will be well-function when meet both the basic functions of this family such as to carry out the task with good family health. While transcultural approach is a nursing service that focuses on the analysis and comparative study of cultural differences which focused on the behavior of individuals or groups, as well as the process for maintaining or improving health behaviors and physical illness behavior and psychocultural appropriate with cultural background (Leininger, 1978). What was found in this study are consistent with that proposed by Angel and Thoits (1987) in which a person or family's perception of the disease is influenced by culture or values are reflected in the implementation of local and family duties.

At this stage the results showed that the family is able to recognize family health problems by identifying the health problems faced by the family. Based on the results of indepth interviews, the majority of participants said that the cause of pain in children are drinking ice cold, tea box, and contracting of his brother. The majority of participants' responses who their children are sick child are fussy, crying, asking carrying. According to Nelson (2002) that the upper respiratory tract infection (ARI) is an infection caused by viruses and bacteria, including nasopharyngitis or common cold, rhinitis, sinusitis. According to the Ministry of Health (MOH) (2005) ARI may be caused by the behavior of individuals such as physical sanitary home and lack of availability of clean water. This is supported also by the results of participant observation in their home environment. 4 out of 6 participants living in the boarding family room live in a room with width of about 3 x 2 m<sup>2</sup>, where environmental conditions much poultry, birds and close to the river. The location of the shelf plate under the bird cage. The environment of participants are also many sellers of ice that are not clean for example ice cubes made from raw water, syrup with artificial sweeteners, and glass washed using water in a basin that is used over and over again.

The second stage of the family's ability is to make decisions in taking appropriate action. Individuals make decisions after a phase of experience or recognition of symptoms (*the symton experience*). Then the family began trying to treat theirself in their own way. In addition, they began to seek information from another family member, neighbor or co-worker.

At this stage the family is able to care for sick family members, knowing the state of illness, treatment is needed, the existence of health facilities required and the resources available in the family (Effendi, 2009).

Families are people who play an important role very close to the people and is considered the most widely know the condition of the patient and is considered the most influence on the patient, so that the family is very important in the treatment and cure of patients (Hariyanto *et al.* 2002).

Source of medical expenses that are generally utilized almost all participants in solving health problems are independent sources, and only one uses health insurance, another participant also mentions getting help from parents The average income is the range of 1.5 to 2 million and the main earner is the husband who works as a driver or private. Economic factors can

also determine the patient or his family treated. According to Friedman (2010) suggests that the task of the components of family health care for family members caring for the sick is not only in the physical but the family has a family support and economic support within the health services covered by the family. In addition, the majority of participants are primary and secondary education so that it is aligned with the results of research in which there are almost half of the participants are believed to bring to an irrational treatment of convulsions. In addition, a slightly different case with proposed by Friedman (2010) that a person who only has basic education but high social sense of the people will affect everyday behavior and thought processes to seek information on the community. Family education is one of the inputs in the process of formation of a new unit of output behaviors that affect the family's ability to perform as expected action (Notoadmojo, 2003). Leininger (1984) explains that the process of confronting and solving problems started from a family where the higher education clients, the conviction must be supported by scientific evidence that rational and can learn to adapt to the culture in accordance with their health condition. Another opinion explains that education and income are components of socioeconomic and family factors play an important role in regulating family members (Ma, 2009). Friedman, Bowden & Jones (2003) explains that the income generated by the family will be used to meet the expenditure of which is to meet the needs of family health. The results showed that the participants also mentioned that at the moment there are family members who are sick parent will provide assistance. This is in line with the manner described by Hanson (2005) in Kaakinen, et. Al, 2010)

The environmental factors greatly affect the client's psychological condition. According to Gordon and Le Richt (1950), environment that is the aggregate of all conditions and external influences affect the life and development of an organization. In general, environmental factors include physical and non-physical environment. The physical environment is a natural environment that are around humans, while non-physical is the environment arising from the interaction between people (Mansjoer *et al.*, 2001).

In terms of environmental factor, the family should be able to maintain a home environment that can affect health and personal development of members of the family. The environment continues to be a concept in the health care of family members. The availability of a healthy environment in the form of adequate shelter is an aspect of family care functions. Home environment needs to be adapted to the development and the family circumstances as well as the overall health of family members (Friedman, 2010). Provision of physical and non-physical environment indirectly interconnected with economic factors.

Families are able to use public resources in order to maintain health. Public perceptions of the health-illness closely related to the health seeking behavior. This is in line with the findings that there are participants who use non-medical treatment through expert convulsions although also went to the facility or healthcare facility. Both the subject matter will affect on the health facilities used or not provided.

This study showed that the majority of participants embrace the values of Javanese culture, ranging from Java language habits, the use of traditional medicines and therapies convulsions

of Java. In the context cultural values and lifestyles became one of the supporting components of transcultural models. Cultural values is something that formulated and defined by the adherents of culture is considered good or bad.

This study has several problems such as: technical constraints related to the process of the interview where distraction occurs while the child is fussy so that the assessment should be stopped temporarily in order to meet the needs of the child's mother. This can cause poor concentration mother but researchers attempted to repeat the question and remind what has been presented based on the results of field notes.

## V. CONCLUSIONS AND RECOMMENDATIONS

Based on previous research results and discussion can be concluded that the family has implemented five family duties in the prevention of infectious diseases in children with relatively simple home treatment for prevention of transmission, utilizing the nearby health facilities are health centers, doctors' offices around, and hospitals in addition to utilizing alternative medicine such as massage and treatment to the experts convulsions as the influence of cultural values Java. Application of their family duties largely influenced by economic conditions and lower-middle education and the influence of Javanese culture. For further studies of community empowerment in the prevention of infectious diseases in children with operational research methods.

## REFERENCES

- [1] Andrews, M & Boyle, JS *Transcultural Concepts in Nursing Care*, Second edition, Philadelphia, JB lippincot Company, 1995.
- [2] Arikunto, S (2002). *Procedure Research: A Practice Education* . Jakarta: Rineka Reserved.
- [3] Creswell, JW (1998), *Qualitative Inquiry and Research Design: Among choosing five tradition*. Thousands oaks: Sage Publications Inc.
- [4] Effendi, F & Makhfudli (2009). *Community Health Nursing: Theory and Practice in Nursing*. Jakarta: Salemba Medical.
- [5] Fitzpatrick, JJ & Whall, AL (1998) *Conceptual Models Of Nursing: Analysis and Application* , Normalk: Appleton & Lange.
- [6] Friedman, MM, Bowden, VR & Jones, EG (2003). *Family Nursing Research: Theory and Practice*. New Jersey: Pearson Education, Inc.
- [7] Friedman (1998). *Family Nursing: Research, Theory and Practice*. Issue 3, EGC: Jakarta.
- [8] Friedman. (2010). *Textbooks family nursing research, theory, dan praktik* (5th edition). Jakarta: Faculty of Medicine, University of Indonesia
- [9] Geiger & Davidhizar, (1995) *Transcultural Nursing Assessment and intervension* , Second edition, St. Louis Mosby.
- [10] Deny Hardita Martha, (2014) *Effect of Health Education Methods Brainstorming on knowledge and attitudes in Preventing Mother to Child ARI Toddlers* , Thesis, Not Published.
- [11] SMH Hanson, Gedaly-Duff, V., Kaakinen., JR (2005) *Family Health Care Nursing: Theory, Practice and Research and Research.*, Philadelphia: FA. Davis Company.
- [12] Kaakinen JR., Gedaly-Duff, V., Coehlo, DP & Hanson, SMH (2010), *Family Health Care Nursing: Theory, Practice and Research*. Philadelphia: FA. Davis Company.
- [13] Leininger, M. (1991). *Culture Care Diversity and Universality: A Theory of Nursing* , the National League for Nursing Press.
- [14] Maglaya, US, Cruz-Earnshaw, RG, Pambid-Dones, LBL, Maglaya, MSC, Lao Narion, MBT & Leon, woud (2009). *Nursing Practice In The Community*. Marikina: Argonauta Corporation.

- [15] Ma, Y (2009), *Family Socioeconomic Status, Parental Involvement, and College Major Choices-Gender, Race / Ethnic, and Nativity Patterns.*, *Socioloical Perspectives*, 5 (2), 211-234.
- [16] Notoadmojo, S (2002). *Health Research Methodology* . Jakarta: Rineka Reserved.
- [17] Notoadmojo, S (2003). *Education and Health Behavior* . Jakarta: Rineka Reserved.
- [18] Nursalam (2008). *Concept and Application of Nursing Research Methodology: Guidelines thesis, and nursing research instrument* . Jakarta: Salemba Medical.
- [19] Polit, DF & Beck, CT (2014). *Nursing Research & Principles & Methods* , 7 th edition, Philadelphia: Lippincott Williams & Wilkins.
- [20] Poerwandari, EK (2005). *Qualitative Approach to Human Behavior Research* . Issue 3. New York: Pefecta LSPSP. Faculty of Psychology, University of Indonesia.
- [21] Streubert & Carpenter (1999). *Qualitative Research in Nursing Advancing the Humanistic Imperative* . Philadelphia: Lippincott
- [22] Speziale, HJS & Carpenter, DR (2003). *Qualitative Research in Nursing* . 3th. Edition. Philadelphia: Lippincott Williams & Wilkins
- [23] Swason, MF (1997). *Pregnancy, Birth, Mother and Baby Care in the Context of Family* , UI Press.
- [24] Sudiharto (2003), *factors that contribute to the implementation of transcultural nursing care by nurses in hospitals Islam Jakarta* , Jakarta Not published.
- [25] Tomey, M. (1994). *Nursing Theorist and Their Wo r k* , Third Edition, St. Louis: Mosby -year Book, Inc.

## AUTHORS

**First Author** – Nuzul Qur'aniati, S.Kep., Ns., M.Ng, Maternity and Child Nursing Department, Faculty of Nursing Universitas Airlangga Surabaya, Email: nuzulbsn@yahoo.com; nuzul-q-a@fkip.unair.ac.id

**Second Author** – Iqlima Dwi K, S.Kep., Ns., M.Kep, Maternity and Child Nursing Department, Faculty of Nursing Universitas Airlangga Surabaya

**Third Author** – Aria Aulia N, S.Kep., Ns., M.Kep, Maternity and Child Nursing Department, Faculty of Nursing Universitas Airlangga Surabaya

# Understand our student's idiomatic phrase?

Valentina Ilieva, PhD

Faculty of Education, Bitola, Macedonia

**Abstract-** The teachers of German should have their work *close at heart, day and night, and should be as busy as bees*, because, contrarily, they will start *mincing words* and their students will *pretend innocence*.

Idiomatic expressions are a very important segment in each and every language. They enable the users of a particular language *to read between lines* and they also highlight the profound cultural features of that language. This paper makes an attempt to put to the foreground that specific small segment of linguistics, culture and national feature of a foreign language, or more precisely, it tackles the case of the Macedonian learners of the German language.

The analysis is carried out on a corpus comprising books assigned as additional reading materials to students who study the German language. In fact, the selected books are primarily analyzed from the perspective of the incidence of idiomatic expressions in them, which is subsequently followed by conducting a survey which targeted students of German who, upon their graduation, would work as teachers of German. The aim of the survey is to test students' understanding of the meaning of some idiomatic expressions as well as the ways in which students go about interpreting them in the additional reading materials that have been assigned to them.

At the end of the paper the obtained results are being presented and commented on. The conclusion highlights the necessity of teachers undertaking a creative approach on their way towards achieving one of the most crucial goals in teaching German as a foreign language which refers to both vocabulary and enabling students to communicate effectively in German. The attempts to translate German idiomatic expression into Macedonian face us with the fact that in that respect in these two languages there are absolute equivalents, semi-equivalents as well as unpredictable idiomatic expressions which could also be treated in the teaching process by providing descriptions and explanations of their meanings.

**Index Terms-** equivalents, idiomatic expressions, intercultural communication, teaching German, semi-equivalents

## I. INTRODUCTION

In the process of teaching German as a foreign language in the Republic of Macedonia, the Education Development Bureau at the Ministry of Education and Science of the Republic of Macedonia has set some general and specific goals.

"Bearing this in mind, students who have successfully completed this subject will be able to:

- communicate in German in everyday life as well as in academic context;

- communicate in German in a specifically directed context of general-educational and mundane character;
- to develop personal skills necessary for their successful functioning as citizens in a democratic society."<sup>1</sup>

In order for students to be able to communicate in everyday and academic context, they should have acquired a certain vocabulary load. In fact, the concrete goals of the 7th component, Vocabulary2, within the curriculum of teaching German proposed by the Education Development Bureau point to the fact that students should enrich their vocabulary by learning new meanings of the already acquired words as well as new words and expressions necessary for taking active participation in communication. This also involves enabling students to make use of bilingual dictionaries.

According to the Common European Framework of Reference<sup>3</sup>, the vocabulary needed for reaching B1 level amounts to 3 500 words<sup>4</sup>. In this context, one should also take into consideration the idiomatic expressions, which although are expected to be mastered at B2 level, yet should be introduced much earlier, i.e. at the lower levels of education. The need for dealing with idiomatic expressions is especially pronounced in the process of teaching the German language as a second language in the second year of high school education<sup>5</sup>.

The 8<sup>th</sup> component, dubbed *Culture*, highlights that "the actual goal of the culture component is to enable students to acquire knowledge and understanding of the socio-cultural characteristics of other countries via vocabulary content and communicative models. This is important as it will ensure building positive attitude towards contributing to both one's own and other people's culture which, in turn, will boost mutual understanding and cooperation ...". In this context, there are examples provided which explicitly advocate the usage of "sayings, proverbs, riddles, idioms and collocations"<sup>6</sup>. According to Friedrich the idiomatic expressions are a specific type of

---

<sup>1</sup> <http://bro.gov.mk/docs/gimnazisko/zadolzitelniPredmeti/Nastavnoprograma-Germanskijazik-I-GO-vtor.pdf>

<sup>2</sup> <http://bro.gov.mk/docs/gimnazisko/zadolzitelniPredmeti/Nastavnoprograma-Germanskijazik-II-GO-vtor.pdf>

<sup>3</sup> <http://www.europaischer-referenzrahmen.de/>

<sup>4</sup> <https://dafdiesunddas.wordpress.com/2012/09/19/empfohlene-stunden-pro-niveaustufe/>

<sup>5</sup>

<sup>6</sup> <http://bro.gov.mk/docs/gimnazisko/zadolzitelniPredmeti/Nastavnoprograma-Germanskijazik-II-GO-vtor.pdf>

<http://bro.gov.mk/docs/gimnazisko/zadolzitelniPredmeti/Nastavnoprograma-Germanskijazik-II-GO-vtor.pdf>



expressions whose meaning differs from the meaning of the individual words they are composed of<sup>7</sup>.

This is the main reason why idiomatic expressions should be included in teaching German as a foreign language and why their meaning should be brought closer to students so that they would be able to understand them and use them when they use German. For instance, let's consider the idiomatic expressions: *die Katze im Sack kaufen* ('buy a cat in a sack'), *eine harte Nuß knacken* ('crack a tough nut') and *durch den Kakao ziehen* ("drag sb through cocoa"). These expressions have nothing to do with cats, nuts or cocoa, in fact, they refer to something completely different. The fact that 'buying a cat in a sack' is, in fact, buying something which the buyer is unfamiliar with; then, 'cracking a tough nut' is overcoming some great, and 'dragging sb. through cocoa' is making fun of somebody, is what makes these expressions idiomatic expressions<sup>8</sup>. Hypothetically, if one is unfamiliar with these idiomatic expressions, he/she may start wondering where the cat, the nut and the cocoa are.

## II. THE LAYOUT OF THE RESEARCH

One of the goals for achieving successful communication in a foreign language is undoubtedly vocabulary acquisition which on its part could be a very complex task. The teacher's approach to reaching this goal could vary considerably depending on a host of factors: the teaching material used in the teaching process; the course books approved for teaching German; the additional materials at teachers' disposal; the creative approach of the teachers themselves in teaching the new vocabulary; how and to what extent the teachers use dictionaries in teaching German and whether they instigate their students to use dictionaries in the process of learning the language etc. Students' vocabulary could not be enriched solely by their attending lectures and writing homework, but also by a lot of other additional activities (e.g. reading texts, short stories, tales, novels, watching films, doing exercises provided online by the publishing houses such as Hueber, Klett-Langenscheidt, Cornelsen etc.) introduced by their teachers or instigated by the environment they live in.

However, with reference to the acquisition of vocabulary which is necessary for everyday communication according to the common goal for learning German in the process of teaching German, one should not lose sight of the fact that the idiomatic expressions should be taken into a very serious consideration. The importance of mastering these word formations in German<sup>9</sup> is especially significant for everyday communication, whereas the opposite tendency can lead to major obstacles in the intercultural communication.

Irrespective of whether we are discussing press, personal correspondence, everyday conversations etc., idiomatic expressions play a major role. The more idiomatic expressions

one knows, the more one is up to date and capable of understanding a text or a conversation completely<sup>10</sup>.

This paper analyzes the acquisition of vocabulary, i.e. of idiomatic expressions present in the extracurricular literature – reading materials intended for A2/B1 level according to the Common European Framework of Reference. Thus, the corpus subjected to analysis here comprises the following:

1. "Der Mond war Zeuge" Ein Fall für Patrick Reich DaF-Lernkrimi A2/B1 Volker Borbein und Marie-Claire Lohéac-Wieders Cornelsen Verlag Berlin 2009
2. "Tödlicher Irrtum" Ein Fall für Patrick Reich DaF-Lernkrimi A 2/B1 Volker Borbein und Christian Baumgarten Cornelsen Verlag Berlin 2009
3. "Das Missverständnis" Großstadtgeschichten DaF-Lektüre A2/B1 Volker Borbein und Christian Baumgarten Cornelsen Verlag Berlin 2013
4. "Die Spur führt nach Bayern" Ein Fall für Patrick Reich DaF-Lernkrimi A2/B1 Volker Borbein und Christian Baumgarten Cornelsen Verlag Berlin 2009
5. "Tödliches Testament" Ein Fall für Patrick Reich DaF-Lernkrimi A2/B1 Volker Borbein und Christian Baumgarten und Thomas Ewald Cornelsen Verlag Berlin 2011
6. "Der letzte Kuss" Ein Fall für Patrick Reich DaF-Lernkrimi A2-B1 Volker Borbein und Christian Baumgarten und Thomas Ewald Cornelsen Verlag Berlin 2010
7. "Großstadtliebe" Großstadtgeschichten DaF-Lektüre A2/B1 Volker Borbein und Christian Baumgarten Cornelsen Verlag Berlin 2012

The analysis was carried out from two distinct perspectives a) an analysis of the books (literary works and crime novels intended for learning the German language as a foreign language) and b) a survey conducted among students who have read these selected literary works assigned to them as homework.

More precisely, the corpus consists of literary works assigned as additional reading materials to students of German at the Faculty of Education – Bitola. All these books are intended for A2/B1 linguistic level according to the Common European Framework of Reference.

## III. THE RESULTS OF THE ANALYSIS

The analysis of the books yielded the results presented on Table 1 below. In fact, the table depicts the titles of the analyzed books, the names of the authors, the genres of the analyzed books, the number of pages of each book and the number of idiomatic expressions present in them. The idiomaticity of the identified idiomatic expressions has been verified by consulting Friedrich's *Idiomatics* and Herzog's *Idiomatic Expressions A-Z*.

<sup>7</sup> W. Friedrich, *Moderne deutsche Idiomatik*. München: Sprachen der Welt Hueber Verlag, 1976, p.7

<sup>8</sup> W. Friedrich, *Moderne deutsche Idiomatik*. München: Sprachen der Welt Hueber Verlag, 1976, p.7

<sup>9</sup> V. Ilieva, *Die Wichtigkeit der Redewendungen im Deutschunterricht*. 2014, submitted for publication.

<sup>10</sup> A. Herzog, *Idiomatische Redewendungen von A-Z*. Langenscheidt, 1993



	titles	authors	genre	no. of pages	idiomatic expressions
1.	„Der Mond war Zeuge“	Volker Borbein und Marie-Claire Lohéac-Wieders	DaF-Lernkrimi	47	4
2.	„Tödlicher Irrtum“	Volker Borbein und Christian Baumgarten	DaF-Lernkrimi	47	2
3.	„Das Missverständnis“	Volker Borbein und Christian Baumgarten	DaF-Lektüre	47	3
4.	„Die Spur führt nach Bayern“	Volker Borbein und Christian Baumgarten	DaF-Lernkrimi	47	4
5.	„Tödliches Testament“	Volker Borbein und Christian Baumgarten und Thomas Ewald	DaF-Lernkrimi	47	4
6.	„Der letzte Kuss“	Volker Borbein und Christian Baumgarten und Thomas Ewald	DaF-Lernkrimi	47	10
7.	„Großstadtliebe“	Volker Borbein und Christian Baumgarten	DaF-Lektüre	48	7

**Table 1**

What follows is a presentation of the idiomatic expressions detected in the analyzed books as well as their meanings according to Friedrich's *Modern German Idiomatics* as a highly relevant source of idiomatic expressions in German:

1. **Der Mond war Zeuge** (a crime novel): *die Nase voll haben* (p.12), *Gespenster sehen* (p.18), *nicht aus dem Kopf gehen* (p.20), *ins Schwarze treffen* (p.34).
2. **Tödlicher Irrtum** (a crime novel): *aus dem Weg räumen* (p.25), *über alle Berge sein* (p.25).
3. **Das Missverständnis (novel)**: *die Übung macht den Meister* (p.8), *etwas auf dem Herzen haben* (p.15), *wie Schuppen von den Augen fallen* (p.36).
4. **Die Spur führt nach Bayern** (a crime novel): *auf den Geschmack kommen* (p.7), *Gespenster sehen* (p.19), *dicht auf den Fersen sein* (p.31), *das Handwerk legen* (p.37).

5. **Tödliches Testament** (a crime novel): *sich einen Ruck geben* (p.11), *unter die Lupe nehmen* (p.25), *wie ein Häufchen Elend aussehen* (p.30), *seinen Augen nicht trauen* (p.36).
6. **Der letzte Kuss** (a crime novel): *die Schnauze halten* (p.8,19), *wie ein Häufchen Elend aussehen* (p.8), *sich näher kommen* (p.10), *Gespenster sehen* (p.19,21), *etwas in der Tasche haben* (p.26), *die Schnauze halten* (p.27), *ein Stein vor Herzen fallen* (p.37), *seinen Augen nicht trauen* (p.38).
7. **Großstadtliebe** (novel): *mit sich und der Welt zufrieden* (p.4), *stellt auf den Kopf*(p.4), *sitzen geblieben*(p. 11), *siehst Gespenster*(p.26), *im siebten Himmel*(p.32), *Himmel und Hölle*(cmp.35), *aus heiterem Himmel*(p.39), *im Stich gelassen* (p.39).

German idiomatic expression	explanation provided by Friedrich or Herzog <sup>11</sup>	Macedonian equivalent
<i>die Nase voll haben</i>	<i>etwas satt haben, nicht mehr wissen wollen von etwas</i> S.335 F	преку глава му е ("head over heels")
<i>Gespenster sehen</i>	<i>Dinge sehen, die gar nicht da sind</i> S.158 F	гледа духови ("seeing ghosts")
<i>nicht aus dem Kopf gehen</i>	<i>immer an etwas (oder jemanden) denken (müssen)</i> S.265 F	не му излегува од глава ("to get sb out of one's head")
<i>ins Schwarze treffen</i>	<i>genau das Richtige sein, großen Erfolg haben</i> S.433 F	погоди право в срце ("to hit sb straight in the heart")
<i>aus dem Weg räumen</i>	<i>(Hindernisse, j-n usw., beiseite schieben</i> S.528 F	си го исчисти теренот ("to sweep out of the way")
<i>über alle Berge sein</i>	<i>(längst) verschwunden sein</i> S.49 F	замина во белиот свет ("the big white world")
<i>etwas auf dem Herzen haben</i>	<i>eine Bitte (oder Beschwerde) haben, die man nicht leicht ausspricht</i> S.210F	има нешто на срце ("to have smth at heart")

<sup>11</sup> A. Herzog, *Idiomatische Redewendungen von A-Z*. Langenscheidt, 1993

<i>wie Schuppen von den Augen fallen</i>	<i>von jemandem plötzlich klar erkannt werden S.429 F</i>	<i>ме фати</i> ("The scales fell from my eyes.")
<i>auf den Geschmack kommen</i>	<i>allmählich Gefallen finden an etwas S.156 F</i>	<i>пополека дојде на моето</i> ("to acquire a taste for it")
<i>dicht auf den Fersen sein</i>	<i>jemanden verfolgen S.121 F</i>	<i>Зад петици е</i> ("to be at sb's heels")
<i>das Handwerk legen</i>	<i>jemanden daran verhindern, etwas Schlechtes zu tun S.194 F</i>	<i>му ги врза рацете</i> ("to put a stop to sb.'s activities")
<i>sich einen Ruck geben</i>	<i>sich zusammennehmen, sich überwinden, energisch etwas anfangen S.390 F</i>	<i>Се надмина себе си и започна нова работа</i> ("to make an effort")
<i>unter die Lupe nehmen</i>	<i>etwas sorgfältig prüfen, exakt beurteilen S.306 F</i>	<i>гледа нешто под лупа</i> ("put under a microscope")
<i>wie ein Häufchen Elend aussehen</i>	<i>ein Mensch der völlig verzweifelt, verängstigt dasitzt S.196 F</i>	<i>изгледа како мизерија</i> ("to look like a picture of misery")
<i>seinen Augen nicht trauen</i>	<i>etwas so Überraschendes sehen, dass man es nicht glauben kann S. 31F</i>	<i>не си верува на сопствените очи</i> ("can't believe one's eyes")
<i>die Schnauze halten</i>	<i>den Mund halten (aber viel grober) S.420 F</i>	<i>да ја затни муцката</i> ("shut up")
<i>sich näher kommen</i>	<i>mit jemandem menschlich vertraut werden S.332 F</i>	<i>се здужија</i> („to close up on sb.,“)
<i>etwas in der Tasche haben</i>	<i>etwas sicher haben S.482 F</i>	<i>го пикна в џеб</i> ("to put smth. in one's pocket")
<i>ein Stein vo Herzen fallen</i>	<i>jemand fühlt sich durch das, was er gehört hat, sehr erleichtert S. 462 F</i>	<i>му падна камен од срце</i> ("to take a load of sb's mind")
<i>auf den Kopf stellen</i>	<i>völlig verdrehen, entstellen S.263 F</i>	<i>Газ преку глава</i> ("upside down")
<i>sitzen bleiben</i>	<i>nicht in e-e höhere Klasse versetzt werden S.446 F</i>	<i>Кепна</i> ("to stay down (a year)")
<i>im siebten Himmel sein</i>	<i>von den Gefühlen höchsten(Liebens)Glücks erfüllt sein S.214 F</i>	<i>е на седмо небо</i> ("be over the moon")
<i>Himmel und Hölle in Bewegung setzen</i>	<i>alles Erdenkliche tun, alle Möglichkeiten versuchen S.214 F</i>	<i>мртвите од гроб да ги станиш</i> ("to move heaven and hell")
<i>aus heiterem Himmel</i>	<i>völlig überrraschend, ohne dass jemand etwas Böses ahnte S.214 F</i>	<i>од ведро небо</i> ("out of the blue sky")
<i>im Stich lassen</i>	<i>jemanden bei einer Gefahr verlassen S.446 F</i>	<i>го остави на џедило</i> ("leave sb. in the lurch")

The analysis of the students' survey suggests that the meaning of some of the idiomatic expressions was not difficult to deduce and the students could immediately come up with their Macedonian equivalent. However, arriving at the meaning of some of the other idiomatic expressions was not that straight forward and the students resorted to literal word by word translation and, eventually, ended up misinterpreting the meanings of the idiomatic expressions. The survey was conducted as a homework assignment as it is assumed that since students have reached B1 and B1+ level have already mastered the idiomatic expressions in the course of their primary and secondary education.

The assignment set in the survey was conceptualized in three separate stages. Firstly, the students were asked to read out the idiomatic expressions listed in a table; then, they were asked to translate them into Macedonian, i.e. to find their Macedonian equivalent. Finally, on the basis on the information about their exact location in the sentences or the paragraphs they were asked to state whether they understand the idiomatic expression in the context or not.

The processing of results of the survey was organized in several categories:

- A) Idiomatic expressions which have been correctly translated and interpreted by providing a Macedonian equivalent;

- B) Idiomatic expressions whose meaning has been understood but no Macedonian equivalent has been provided;
- C) Idiomatic expressions whose knowledge has not been understood and no Macedonian equivalent has been provided.

Out 15 surveyed students and 25 idiomatic expressions included in the survey, 375 entries have been processed -198 entries in the category A, 122 entries in the category B and 55 entries in the category C.

Some of the idiomatic expressions (“be over the moon”, “be at sb’s heels”, “to take a load of sb’s mind”, “out of the blue sky”, “to be close at sb’s heart”, “not believe one’s eyes” etc.) were completely identical in both German and Macedonian. Some of the idiomatic expressions (“get one’s foot in the door”, “looks like a wet blanket”, “shut up”, “have something in the bag”) were correctly interpreted but no Macedonian equivalent were provided by the students. The last category referred to the idiomatic expressions whose meaning was unclear to the students and for which the students were not in a position to offer any Macedonian equivalent idiomatic expressions (“it gets better and better”, “falls like a curtain in front of one’s eyes”, “one’s hands are tied”).

The third and the last part of the assignment involved reading the entire sentence or a paragraph and trying to deduce the meaning of the idiomatic expressions from the context. The results of the survey showed that in the case of 27 entries the context proved to be completely unhelpful in clarifying the meaning of the idiomatic expression.

#### IV. CONCLUSION

On the basis of this research it could be concluded that Macedonian learners of the German language could easily recognize the meaning of those idiomatic expressions which have Macedonian equivalents. These idiomatic expressions, according to Plotnikov<sup>12</sup>, could be classified as absolute equivalents. However, considering the fact that there are many idiomatic expressions which do not have absolute equivalents, it is easy to assume that they could very easily hinder the communication of Macedonian learners with German speaking interlocutors. Hence, this category of idiomatic expressions should be dealt with by means of various creative exercises and the efforts of the both teachers and students should be directed at finding their semi-equivalents (which will have the same meaning but different subjects or objects).

The most intricate case is understandingly the case of those idiomatic expressions which are nonexistent in the Macedonian learners’ mother tongue, as their meaning (which could sometimes be derived from the context, but not always) should be described. However, this hindrance could also be overcome provided that teachers are sufficiently committed to this task and are willing to apply a creative approach which will boost pupils and students’ acquisition of German. This is very important since, at the end of the day, the understanding and usage of idiomatic expressions and phraseologies is, in fact, one of the

most important indicators of the extent to which a particular foreign language has been mastered by its learners<sup>13</sup>.

#### REFERENCES

- [1] A. Herzog unter Mitwirkung von Arthur Michel und Herbert Riedel, *Idiomatische Redewendungen von A-Z*. Langenscheidt, 1993
- [2] B. A. Plotnikov, *Frazeologija*. Minsk 1983
- [3] P. Mrazovic & R. Primorac, *Deutsch-Serbokroatisches Phraseologisches Wörterbuch*. Beograd: Narodna, 1974
- [4] S. Velkovska, *Notes on Macedonian Phraseology*. Institute of Macedonian language 2002
- [5] V. Ilieva, *Die Wichtigkeit der Redewendungen im Deutschunterricht*. 2014, submitted for publication.
- [6] W. Friedrich, *Moderne deutsche Idiomatik*. München: Sprachen der Welt Hueber Verlag, 1976
- [7] <http://bro.gov.mk/docs/gimnazisko/zadolzitelnipredmeti/Nastavnaprograma-Germanskijazik-I-GO-vtor.pdf>
- [8] <http://bro.gov.mk/docs/gimnazisko/zadolzitelnipredmeti/Nastavnaprograma-Germanskijazik-II-GO-vtor.pdf>
- [9] <http://www.europaischer-referenzrahmen.de/>
- [10] <https://dafdiesunddas.wordpress.com/2012/09/19/empfohlene-stunden-pro-niveaustufe/>

#### AUTHORS

**First Author** – Valentina Ilieva PhD, Faculty of Education, Bitola, Macedonia, [kommtina@yahoo.de](mailto:kommtina@yahoo.de)

<sup>12</sup> B. A. Plotnikov, *Frazeologija*. Minsk 1983 pp.221-236

<sup>13</sup> S. Velkovska, *Notes on Macedonian Phraseology*. Institute of Macedonian language 2002 p.82

# HIV/Aids-Tuberculosis (Pulmonary and Extra Pulmonary) Co- Infection: Sputum Positivity and Cd4 Correlation

Dr. R. Siddeswari\*, Dr. B. Sudarsi\*\*, Dr. Sanjeev\*\*\*, Dr. B. Suryanarayana\*\*\*\*, Dr. S. Manohar\*\*\*\*\*, Dr. Abhilash\*\*\*\*\*

\* M.D., Prof. of Medicine, Osmania General Hospital, Hyderabad, Telangana State, India.

\*\* M.D., Asst Prof. of Medicine, Osmania General Hospital, Hyderabad, Telangana State, India.

\*\*\* MBBS., Med Officer in ART Centre, Osmania General Hospital, Hyderabad, Telangana State, India.

\*\*\*\* M.D., Asst Prof. of Medicine, Osmania General Hospital, Hyderabad, Telangana State, India.

\*\*\*\*\* M.D., Professor & HOD of Medicine, Osmania General Hospital, Hyderabad, Telangana State, India.

\*\*\*\*\* (M.D). PG, Osmania General Hospital, Hyderabad, Telangana State, India.

**Abstract-** The present study aims to find a correlation between sputum positivity and CD4 cell count in patients with HIV/AIDS-Tuberculosis co infection. It was as a retrospective hospital based observational study. Data was collected over a period of one year in the ART CENTRE, Department of Medicine, Osmania General Hospital. We included 350 HIV/AIDS infected patients on ART with Tuberculosis co infection.

**Index Terms-** Human Immuno Deficiency Virus, Tuberculosis, CD4 Count, opportunistic infection.

## I. INTRODUCTION

Tuberculosis is the most common opportunistic infection in HIV/AIDS and is the most common cause of death in HIV/AIDS patients. Early diagnosis and treatment can decrease the mortality and morbidity. HIV enters the body when an individual comes in contact with infected blood, semen and/or vaginal secretions. The CD4 receptor is the principal target site for HIV. <sup>(1)</sup>

A normal CD4 count in a healthy, HIV-negative adult can vary but is usually between 500 and 1500 CD4 cells/mm<sup>3</sup> (though it may be lower in some people).<sup>(2)</sup>

The principal impact of HIV infection on the immune system is destruction of the CD4 T-lymphocytes. During primary infection, HIV and HIV-infected cells reach the lymph nodes and other lymphoid tissues. The virus rapidly disseminates during this early phase of HIV infection. As a result, there is a significant fall in CD4 cells and viral levels, may be as high as 106-107 viral copies/ml. The next stage is down regulation of viraemia.

This coincides with a robust, intense immune response by the host. Both effective cellular immune response mediated by HIV specific cytotoxic T-lymphocytes (CTLs) and humoral response mediated by complement fixing and neutralising HIVspecific antibodies comes into play. As a result, the viraemia drops and CD4 levels bounce back to values slightly lower than the normal levels. However, active and continuous virus replication continues in the lymph nodes and lymphoid

organs. In active phase of infection, CD4+ loss can be up to 2 million cells per day. Sometime loss of non-infected cells can be more than that of infected cells. In the initial phases of infection, enormous loss does not reflect as an immediate, proportionate drop in their blood count, due to compensatory proliferation of precursor cells.

CD4+ counts start dropping, when the virus kills lymphoid precursor cells and replenishment of lost cells becomes increasingly inadequate. Even non infected cells suffer 'accelerated apoptotic death' (AAD), induced by excess, prolonged activation. Molecular basis of AAD is not clear. Non-infected cells, carrying viral antigens on the surface, are sequestered by anti-viral IgM/IgG antibodies and killed by cytotoxic lymphocyte (CTL) T-cells. Opportunistic infection (OI) is a disease caused by microbial agent(s) in hosts with defects in humoral and cell mediated immunity. Immuno compromised secondary to human immunodeficiency virus (HIV) infection, use of immune modulatory agents (including steroids and anticancer drugs) are emerging predisposing factors to OI.

## II. MATERIAL AND METHODS

It was as a retrospective hospital based observational study. Data was collected over a period of one year in the ART CENTRE, Department of Medicine, Osmania General Hospital. We included 350 HIV/AIDS infected patients on ART with Tuberculosis co-infection.

### Investigations:

Complete blood picture, serum creatinine, Blood urea, serum electrolytes, Liver function tests, Sputum for Acid fast bacilli smear, Chest radiography, CD4 cell Count, Fine needle aspiration and biopsy (if necessary), Magnetic Resonance imaging (if necessary), Computerized Tomography (if necessary), Colonoscopy (if necessary).

## III. RESULTS

Out of 350 patients, 228 were male and 122 were female of which most of them are falling between age groups 20-29 years

[males-42 (12%), females-33 (9.4%)], 30-39 years [males-86 (24.6%), females-55 (15.7%)], 40-49years [males-72 (20.6%), females-29(8.3%)]. Total 71 (20.3%) cases were sputum positive. Sputum negative cases included both sputum negative pulmonary tuberculosis and extra pulmonary which included 279 cases(79.7%)of which sputum negative pulmonary tuberculosis cases 111(39.8%),extra pulmonary tuberculosis cases are 168(60.2%).

CD4 cell count in sputum positive cases with CD4 cell Count< 200/mm<sup>3</sup> -37(52.1%), 200-400 cells / mm<sup>3</sup>-23(32.4%), >400cells / mm<sup>3</sup>-11 (15.5%). In sputum Negative Pulmonary tuberculosis cases, CD4 cell count <200 cells/cumm -80 (28.7%), 200-400cells / cumm-26 (9.3%), > 400cells / cumm- 5 (1.8%). Extra pulmonary tuberculosis cases with CD4 cell count < 200 cells/cumm-111 (39.7%), 200-400 cell/cumm-41 (14.4), >400 cells/cumm-16 (6.1%).

**Table1:CD4 CELL COUNT IN SMEAR POSITIVE PULMONARY TUBERCULOSIS**

GENDER	CD4<200	CD4 BETWEEN 200-400	CD4>400	TOTAL
FEMALE	12(16.9%)	6(8.5%)	3(4.2%)	21(29.6%)
MALE	25(35.2%)	17(23.9%)	8(11.3%)	50(70.4%)
TOTAL	37(52.1%)	23(32.4%)	11(15.5%)	71(100%)

**Table2:CD4 CELLCOUNT IN SMEAR NEGATIVE PULMONARY TUBERCULOSIS**

GENDER	CD4<200	CD4 BETWEEN 200-400	CD4>400	TOTAL
FEMALE	28(25.2%)	9(8.1%)	1(0.9%)	38(34.2%)
MALE	52(46.9%)	17(15.3%)	4(3.6%)	73(65.8%)
TOTAL	80(72.1%)	26(23.4%)	5(4.5%)	111(100%)

**Table3:CD4 CELLCOUNT IN EXTRA PULMONARY TUBERCULOSIS**

GENDER	CD4<200	CD4 BETWEEN 200-400	CD4 >400	TOTAL
FEMALE	45(26.8%)	12(7.1%)	5(3%)	62(36.9%)
MALE	66(39.3%)	29(17.3%)	11(6.5%)	106(63.1%)
TOTAL	111(66.1%)	41(24.4%)	16(9.5%)	168(100%)

**IV. DISCUSSION**

Opportunistic infections (OIs) may serve as indicators of underlying HIV infection. Mortality among HIV-infected individuals is due to improper awareness and consequent poor

clinical management of OIs. HIV load increases in the presence of ongoing OIs, thus accelerating progression to clinical acquired immunodeficiency syndrome (AIDS). The incidence of Opportunistic Infections(OI) range from 10.7 to 69.7 /100 patient years.



Among 28 OIs—tuberculosis (65%), candidiasis (57.5%) and diarrhoeal diseases (40%) are the most common OIs found in Indian patients.<sup>(3)</sup>

According to an estimate of World Health Organisation (WHO), TB has become one of the leading causes of death among HIV-infected persons.<sup>(4)</sup>

The risk of developing TB after an infectious contact has been estimated to be 5-15%/year in HIV-1 infected patients (compared to 5-10% during life time of non HIV-1 infected patients)<sup>(5)</sup>

In India the incidence of TB is around 40% in the general population; however, it has been estimated that around 25-30% more cases of TB may be added due to HIV infection.<sup>(6)</sup>

Active TB is the commonest OI among HIV infected individuals and is also the leading cause of death in PLHA. Surveys in India shows 1-13% HIV among TB patients.<sup>(7)</sup>

Even in HIV infected patients, Pulmonary TB is the most commonest form of TB.<sup>(8)</sup>

Changes in the CD4 lymphocyte count occur with the institution of highly active antiretroviral therapy (HAART).

A critical marker of immunologic integrity is the CD4 cell count, and the clinical manifestations of tuberculosis vary with the CD4 cell count in HIV-positive patients with tuberculosis.<sup>(9)</sup>

Patients with tuberculosis manifest significant immunologic abnormalities including anergy and failure of T-lymphocytes to proliferate and produce IFN-alpha in response to mycobacterial antigens.<sup>(10)</sup>

CD4 cell counts in HIV-negative patients with tuberculosis have been reported to be normal or low, and no clear relationship has been noted between the clinical presentation and CD4 cell count.<sup>(11-15)</sup>

Tuberculosis can occur at any CD4 cell count. Pulmonary tuberculosis is more common at CD4 counts between 200-500/microL. Miliary and extra pulmonary tuberculosis at less than 200 cells/microL. MAC at Less than 50 cells/microL.

HIV infected smear positive patients tend to excrete significantly fewer organisms per ml of sputum than HIV-negative patients which can lead to AFB being missed if the appropriate number of sputum samples as well as high power fields is not examined by microscopy.<sup>(16)</sup>

The Sputum negativity tends to increase as the HIV disease and immune suppression progresses. Diagnosis of TB is based on clinical impression and relevant investigations including chest radio graph, sputum examination, tissue /blood culture for Mycobacterium tuberculosis and biopsy when deemed necessary. HIV serological testing is performed using ELISA method and confirmed by Western Blot. Absolute CD4 lymphocyte counts are quantified. Severe immune suppression is defined as CD4 cells <200/cumm.<sup>(17)</sup>

#### Treatment:

Patients were treated based on RNTCP and NACO Guidelines. Anti tuberculosis therapy (ATT) must be administered according to the directly observed treatment-short course (DOTS) regimen. Institution of Highly active Antiretroviral therapy (HAART) is recommended 10-14 days after institution of ATT in patients with CD4 counts less than 200 cells/mm<sup>3</sup>. In patients with CD4 counts over 200 cells/mm<sup>3</sup> HAART may be commenced 2-8 weeks after the institution of

ATT. As rifampicin is known to enhance the metabolism of protease inhibitors and nevirapine., efavirenz based antiretroviral therapy (ART) is recommended while patients are on rifampin.

#### V. CONCLUSION

- In our study we conclude that male sex under Age group (20 – 29) are more common, sputum negativity incidence is 79.7% and sputum positivity 20.3% CD4 cell count < 200 in sputum positive cases 52%, sputum negative pulmonary tuberculosis in 28%, extra pulmonary tuberculosis in 39.7%.
- Even though sputum positivity did not correlate well with CD4 cell count, sputum negativity increased with decrease in CD4 cell count. With arbitrary cut off of CD4 cell count of <200, the incidence of extra pulmonary tuberculosis was higher.

#### VI. LIMITATIONS OF STUDY

- It is a retrospective study.
- Survival rates were not assessed in the patients who are started on early HAART in CD4 count between 0 - 200.
- Patients were not followed up.

#### REFERENCES

- [1] V Ravi, Anita Desai. Section 16 HIV and AIDS 16.2, Virology, Immunology and Diagnosis, API TEXTBOOK OF MEDICINE, 9E, Pg 1014-16.
- [2] <http://www.aidsmap.com/CD4-cell-counts/page/1044596/>. Last accessed on 31 April, 2014.
- [3] Natasha Edwin, Dilip Mathai. Section 16 HIV and AIDS, 16.7 Opportunistic infections, API TEXTBOOK OF MEDICINE, 9E, Pg 1032-35.
- [4] World Health Organisation. Tuberculosis facts 2007. PDF Icon Non-CDC Web Link. Available from: <http://www.cdc.gov/hiv/tb.htm> (Last Accessed on 2008 Jan 14)
- [5] Raviglione M, Harries A, Msia R, Wilkinson D, Nunn P. Tuberculosis and HIV: Current status in Africa. AIDS 1997; 11(9 suppl B): S115-S123.
- [6] Raviglione MC, Snider DE, Kochi AA. Global epidemiology of tuberculosis morbidity and mortality of a world wide epidemic. JAMA 1995; 273: 220-6.
- [7] Swaminathan S and Narendran G. HIV and Tuberculosis in India. J. Biosci 2008; 33: 527-37.
- [8] WHO TB/HIV A Clinical Manual. Geneva (WHO/HT/TB/2004.329).
- [9] Jones BE, Young SMM, Antoniskis D, Davidson PT, Kramer F, Barner P. Relationship of the manifestations of tuberculosis to CD4 cell counts in patients with HIV infection. Am J Respir Dis 1993; 148: 1292-7.
- [10] Barnes PF, Modlin RL, Ellner JJ. T-Cell responses and cytokines. In: Bloom BR., ed Tuberculosis : pathogenesis, protection and control Washington DC: American Society for Microbiology ; 1994: 417-35).
- [11] Onwaubalili JK, Edwards AJ, Palmer L. T4 Lymphopenia in human tuberculosis. Tubercle 1987; 68: 195-200
- [12] Beck JS, Potts RC, Kardjito T, Grange JM. T4 Lymphopenia in patients with active pulmonary tuberculosis. Clin Exp Immunol 1985; 60: 49-50
- [13] Singhal M, Banavalikar JN, Sharma S, Saha K. Peripheral blood T lymphocytes subpopulation in patients with tuberculosis and the effect of chemotherapy. Tubercle 1989; 70: 17
- [14] Turret GS, Telzak EE. Normalisation of CD4+ T-lymphocyte depletion in patients without HIV infection treated for tuberculosis. Chest 1994; 105: 1335-7
- [15] Bose M, Gupta A, Banavalikar JN, Saha K. Dysregulation of homeostasis of blood T-Lymphocyte subpopulations persists in chronic multibacillary pulmonary tuberculosis patients refractory to treatment. Tuberc Lung Dis 1995; 76: 59-64

- [16] American Thoracic Society .Diagnostic standards and classification of tuberculosis in adults and children.Am J Respr Crit care Med 2000;161:1376-95
- [17] Rieder HL,Cauther GM,Comstock GW & Snider DE(1989).Epidemiology of tuberculosis in the United States.Epidemiologic Reviews 11,79-98

#### AUTHORS

**First Author** – Dr. R. Siddeswar, M.D., Prof. of Medicine, Osmania General Hospital, Hyderabad, Telangana State, India.

**Second Author** – Dr. B. Sudarsi, M.D., Asst Prof. of Medicine, Osmania General Hospital, Hyderabad, Telangana State, India.

**Third Author** – Dr. Sanjeev, MBBS., Med Officer in ART Centre, Osmania General Hospital, Hyderabad, Telangana State, India.

**Fourth Author** – Dr. B. Suryanarayana, M.D., Asst Prof. of Medicine, Osmania General Hospital, Hyderabad, Telangana State, India.

**Fifth Author** – Dr. S. Manohar, M.D., Professor & HOD of Medicine, Osmania General Hospital, Hyderabad, Telangana State, India.

**Sixth Author** – Dr. Abhilash, (M.D). PG, Osmania General Hospital, Hyderabad, Telangana State, India.

# Serum MDA (Malondialdehyde), hs-CRP and Adenosine Deaminase Levels in Pulmonary Tuberculosis Patient's

EswarReddy Kandukuri \*, D.V.H.S.Sarma \*\*, P.Sushma \*\*\*, D.Moulali \*\*\*\*, Asiya naaz \*\*\*\*\*

\*Tutor, Department of Biochemistry, S.V.S. Medical college, Mahabubnagar, Telangana.

\*\* Professor & HOD, Department of Biochemistry, S.V.S. Medical college, Mahabubnagar, Telangana.

\*\*\* Assistant Professor, Department of Biochemistry, S.V.S. Medical college, Mahabubnagar, Telangana.

\*\*\*\* Assistant Professor, Department of Biochemistry, S.V.S. Medical college, Mahabubnagar, Telangana.

\*\*\*\*\* Assistant Professor, Department of Biochemistry, S.V.S. Medical college, Mahabubnagar, Telangana.

**Abstract-** Tuberculosis, one of the oldest infectious diseases known to affect humans, as well as cattle is a major cause of death worldwide. This disease, which is caused by bacteria *Mycobacterium tuberculosis* complex, usually affects the lungs, although other organs are involved in up to one-third of cases. Transmission usually takes place through the airborne spread of droplet nuclei produced by patients with infectious pulmonary tuberculosis. More than 5 million new cases of tuberculosis (all forms, both pulmonary and extra pulmonary) were reported to the World Health Organization (WHO) in 2005; >90% of cases were reported from developing countries of Asia (4.9 million), Africa (2.6 million), the Middle East (0.6 million), and Latin America (0.4 million).

Recent data on trends indicate that in 2005 tuberculosis incidence was stable or falling in most regions; the result is a small decline globally from figures in previous years. This global reduction is due largely to an apparent peaking in sub-Saharan Africa, where incidence had risen steeply since the 1980s as a result of the HIV epidemic and the paucity of health services. In Eastern Europe, incidence increased during the 1990s because of deterioration in socioeconomic conditions and the healthcare infrastructure; however, after peaking in 2001, incidence has recently stabilized. (1) Two out of every five Indians are infected with TB bacillus. Every day about 5,000 people develop the disease. Patients with infectious pulmonary tuberculosis disease can infect 10-15 persons in a year. In India almost 0.37 million people die every year. In the year 2006 the programme had achieved a case detection rate of 66 percent as against global target of 70 percent. In the present study is undertaken with the aim of estimating the following biochemical parameters in the serum of pulmonary tuberculosis patients and analysing the changes with reference to the severity of the disease. 1. Malondialdehyde (MDA), 2. High sensitivity c-reactive protein (hs-CRP), 3. Adenosine deaminase (ADA).

**Index Terms-** Serum malondialdehyde (MDA), serum hs-CRP, Serum Adenosine deaminase (ADA) levels.

## I. INTRODUCTION

Tuberculosis, one of the oldest diseases known to affect humans, it particularly in under developed and developing countries is a Major cause of death worldwide. This disease, which is caused by Bacteria of the *Mycobacterium tuberculosis*

complex, usually affects the lungs, although other organs are involved in up to one-third of cases. If properly treated, tuberculosis caused by drug-Susceptible strains are curable in virtually all cases. If untreated, the disease may be fatal within 5 years in 50–65% of cases. Transmission usually takes place through the airborne spread of Droplet nuclei produced by patients with infectious pulmonary Tuberculosis. (1) More than 5 million new cases of tuberculosis (all forms, both Pulmonary and extra pulmonary) were reported to the World Health Organization (WHO) in 2005; 90% of cases were reported from Developing countries. The number of reported cases began to increase in the late 1980s to the early 1990s this is attributed to acquire immune deficiency syndrome (AIDS), epidemic, homelessness and decreased focus on tuberculosis control Programs.

This increase in MTB infections focused considerable attention on the development of assays for the rapid diagnosis of MTB infections and molecular methods were at the center of the effort. The goal was to design very sensitive assays that would allow for the direct detection of MTB from clinical specimens. However, this goal has proven to be more difficult to reach than originally anticipated. The standard methods for detection of MTB include Acid-Fast Bacilli (AFB) smear and conventional liquid culture methods which are associated with increased risk of developing tuberculosis. Tuberculosis is an important socio economic problem in our country and it is closely linked with health education, health consciousness, and preventive awareness. (2)

The Pulmonary tuberculosis both markers of active inflammatory process, MDA and hs-CRP levels are increased indicating tuberculosis diseases process is active. Hence it can be concluded that in addition to serum ADA levels, estimation of MDA and hs-CRP levels are useful biochemical parameters to assess whether the tuberculosis disease process active as identification and culture AFB is a time consuming process.

## II. MATERIALS AND METHODS

The present study is conducted in the Department of Biochemistry and Department of CHEST AND T.B, S.V.S. Medical College and Hospital, Mahabubnagar. A total of 30 pulmonary tuberculosis patients were studied. Among these 15 were cases and 15 were controls. Each subject was selected as per inclusion criteria. on the basis of vital signs like cough; fever,

headache, AFB-positive, Mantoux test-positive chest x-ray etc. The biochemical parameters of cases were compared with those of normal (control group) persons.

**Collection of Blood Samples:**

About 2ml of blood is collected under aseptic condition. It is allowed to clot and serum is obtained, with precautions to avoid hemolysis. With that sample Serum malondialdehyde (MDA), hs-CRP and Adenosine deaminase (ADA) levels. All investigations were done on same day of sample collection.

Malondialdehyde is estimated by Thiobarbituric acid (TBA) method, (8)

Estimation of hs-CRP by Chemiluminescence immunoassay (CLIA).

Estimation of adenosine deaminase (ADA) levels by Spectrophotometric method of Giusti and Galanti. (9,10)

**III. RESULTS**

The present study included a total number of 30 subjects comprising of 15 cases and 15 controls. The following table shows the comparative statistical analysis of the laboratory parameters used in assessing the serum malondialdehyde (MDA), hs-crp and Adenosine deaminase levels in pulmonary tuberculosis patients.

**COMPARATIVE STATISTICAL ANALYSIS OF ALL BIOCHEMICAL PARAMETERS in controls and cases**

S.no	Investigation	Values	Controls	Cases
1.	MDA	Mean	291.46	523.28
		S.D	64.55	133.78
		S.E	16.66	34.54
		t-value	6.0441	
		p-value	<0.0001	
2.	hs-CRP	Mean	1.52	22.94
		S.D	0.85	10.84
		S.E	0.22	2.08
		t-value	7.6226	
		p-value	<0.0001	
3.	ADA	Mean	21.54	50.93
		S.D	5.24	11.15
		S.E	1.35	2.87
		t-value	9.2357	
		p-value	<0.0001	

S.D: Standard deviation S.E: Standard error mesn

**Statistical Analysis:** Mean and standard deviation (S.D.) of all variables were calculated and compared with those of controls. Statistical significance was assessed by applying the student's t-test, p-value <0.01 were considered significant.

**IV. DISCUSSION**

Tuberculosis, one of the oldest diseases known to affect humans, its prevalence is high under developed and developing countries and an important cause for morbidity, mortality in worldwide. This disease is caused by bacteria of the *Mycobacterium tuberculosis* complex, it is a major global health problem and even in developed countries there is a resurgence of tuberculosis infection due to the growing number of people infected with Human Immunodeficiency Virus (HIV). Early confirmatory diagnosis of tuberculosis is difficult to establish because of its pleomorphic clinical presentation. Delayed diagnosis and treatment may be associated with many serious complications. The most commonly used laboratory method for definitive diagnosis of tuberculosis is to demonstrate the presence of tubercle bacilli either by smear or culture of sputum and biological fluids. Newer methods such as those involving the implication of bacterial DNA by the PCR and comparable systems, are not available for wide spread use in primary and medium level health care centers. The sensitivity of PCR technique varies from 30% to 90% and the specificity from 88% to 100%. Various immunoassays such as antigen and/or antibody detection in CSF samples have been developed with variable sensitivities and specificities. Hence, despite extensive work on TB, only few specific diagnostic tests are available.

The present study is aimed to find any relationship for its specific marker ADA levels and inflammatory markers like MDA and hs-CRP. ADA has been considered as a marker of cell-mediated immunity and its activity has been studied in various infections including TB. Considering that both humoral and cell-mediated immunity play an important role in tuberculosis infection, it has been suggested that ADA activity in serum and biological fluids is highly specific and sensitive biochemical marker for tuberculosis. (3,4)

The determination of ADA activity in controls and tuberculosis patients showed value of 21.54±5.24U/L and 50.93±11.15U/L respectively showing there by ADA values are increased in test group indicating active inflammatory process. Many reports have shown the levels of ADA in serum are elevated in patients suffering with pulmonary tuberculosis patients. The ADA values in the cases studied here are above that of cut off values for the diagnosis of pulmonary tuberculosis. Based upon ADA values and other investigations patients were put on anti tuberculosis treatment and their response to treatment was clinically followed up. All cases who are treated for tuberculosis based upon ADA values responded well for treatment. Serum ADA was found to be a selective marker of immune stimulation in tuberculosis. Abnormally high levels of serum ADA in all the patients with pulmonary tuberculosis indicates that serum ADA could be a good diagnostic tool for pulmonary tuberculosis.

Malondialdehyde is a metabolic product of prostaglandins which are formed as result of peroxidation of poly unsaturated fatty acid (PUFA). Severe oxidative stress can cause increased lipid peroxidation and elevated MDA levels. During pulmonary inflammation, increased amounts of ROS (reactive oxygen species) and Reactive nitrogen intermediates (RNI) are produced as a consequence of phagocytic respiratory burst. One of the

manifestations of these mediated processes is lipid per oxidation. (5, 6) The determination of MDA levels in controls and tuberculosis patients showed value of  $291.46 \pm 64.55$  nmol/dl and  $523.28 \pm 133.78$  nmol/dl respectively showing there by MDA values are increased in test group. Indicating active inflammatory process present in these cases.

High sensitivity C - reactive protein is one of the acute phase proteins that increase during systemic inflammation. The increased levels of CRP indicate that pulmonary tuberculosis is associated with an inflammatory response. (7) The determination of hs-CRP levels in controls and tuberculosis patients showed value of  $1.52 \pm 0.85$   $\mu$ g/ml and  $22.94 \pm 10.84$  respectively showing there by hs-CRP values are increased in test group, indicating active inflammatory process present in these cases.

The present study both markers of active inflammatory process, MDA and hs-CRP levels are increased indicating tuberculosis diseases process is active. Hence it can be concluded that in addition to serum ADA levels, estimation of MDA and hs-CRP levels are useful biochemical parameters to assess whether the tuberculosis disease process active as identification and culture AFB is a time consuming process.

## V. CONCLUSION

The results of present study of estimation of ADA levels along with MDA and hs-CRP levels in serum of tuberculosis patients admitted in our hospital show that ADA, MDA, hs-CRP values are elevated in all cases of clinically proved cases of tuberculosis infection. The results confirms that MDA, hs-CRP and ADA are interrelated in tuberculosis indicating active inflammatory process, With the increased peroxidation of membrane lipids there is release of membrane bound ADA enzyme in plasma. The present biochemical markers analysed in clinically and microbiologically proved tuberculosis patients are simple inexpensive and rapid tools for the early detection of disease and may help in preventing impending complication and mortality rate as a result of tuberculosis infection in population.

## REFERENCES

- [1] Harrison's principles of international medicine 17th edition
- [2] Tietz Textbook of clinical chemistry and molecular diagnostics fourth Edition
- [3] T.B control report 2009-Global Tuberculosis control. A short update to the 2009 REPORT. World health organization (WHO) Library cataloguing-in publication Data. 'WHO/HTM/TB/2009.426' Accessed at 10 march 2010
- [4] Pettersson T, Klockars M, Weber TH: Diagnostic value of cerebrospinal fluid adenosine deaminase determination. Scand J Infect Dis 1991, 23:97-100.
- [5] Williams textbook of obstetrics and gynecology 20th Edition Cunningham Mac Donald Leveno gilstrap Hankins dark
- [6] Kwiatkowskas, piasecka G, Zieba M, Piotrowski W, Nowak D. Increased serum concentrations of conjugated dienes and malondialdehyde in patients with pulmonary tuberculosis Respire Med 1999; 93(4):272-276
- [7] 5.Harper's illustrated Bio-chemistry international 28th Edition Robert k.murray david A. bender Kalthleen M. botham peter J. kennely victor W. Rodwell P.Anathony weil
- [8] Dillard Kunert k,j, Tappel. Effects of vitamin E Ascorbic acid and mannitol on alloxan-induced Lipid per oxidation. Arch Biochem Biophysics 1982; 216(1): 204-212.

- [9] Giusti, G. Adenosine deaminase in: H.U.Burgneyer. Method of enzymatic analysis, 2nd Edition. Academic press.N.Y
- [10] Henry, 1974, p.522.

## AUTHORS

- First Author** – EswarReddy Kandukuri, Tutor, Department of Biochemistry, S.V.S. Medical college, Mahabubnagar, Telangana  
**Second Author** – D.V.H.S.Sarma, Professor & HOD, Department of Biochemistry, S.V.S. Medical college, Mahabubnagar, Telangana.  
**Third Author** – P.Sushma, Assistant Professor, Department of Biochemistry, S.V.S. Medical college, Mahabubnagar, Telangana.  
**Fourth Author** – D.Moulali, Assistant Professor, Department of Biochemistry, S.V.S. Medical college, Mahabubnagar, Telangana.  
**Fifth Author** – Asiya naaz, Assistant Professor, Department of Biochemistry, S.V.S. Medical college, Mahabubnagar, Telangana.



# Neem based formulations used against bud fly, *Dasyneura lini* Barnes in Linseed (*Linum usitatissimum*) crop

S. DEOLE<sup>a1\*</sup>, GUPTA, A. K.<sup>a2</sup>, D. DASH<sup>b</sup>

\* Department of Entomology, College of Agriculture, Indira Gandhi Krishi Vishwavidyalaya, Raipur, Chhattisgarh, India-492012

\*\* Department of Agricultural Microbiology, College of Agriculture, Indira Gandhi Krishi Vishwavidyalaya, Raipur, Chhattisgarh, India-492012

**Abstract-** This investigation was conducted at Deptt. Of Entomology, IGKV, Raipur during rabi season 2009-2010. The efficacy of neem- based formulations to evaluate against linseed bud fly, *Dasyneura lini* Barnes in linseed crops. It was done under Randomized block design (RBD) with three replications. Among different formulations the NSKE 5% was found best with percent damage of 10.80 followed by Neem Seed Coat Extract (NSCE) 5% whereas, commercial Neem product (Nimbolin) gave only 13.30% bud infestation and untreated plot performed higher bud infestation of 29.07 per cent.

**Index Terms-** *Dasyneura lini* Barnes, Linseed bud fly, Neem-based formulations.

## I. INTRODUCTION

Oilseeds occupy an important position in agriculture and industrial economy next to food grains in terms of area, production and value. The cultivated oilseeds comprise nine different crops namely groundnut, soybean, niger, rapeseed, mustard, sunflower, safflower and sesamum as edible oilseeds and castor and linseed as industrial oil crops (Mukherji et.al., 1999) Linseed is an important oilseed crop in India Linseed occupies a greater importance among oilseeds owing to its various uses and special qualities.

<sup>14</sup>

It is grown mainly for seed used for extracting oil in rainfed conditions. The oil content of the seed varies from 33-47%. Linseed oil is excellent dyeing oil used in manufacturing paints and varnishes, oilcloth, waterproof fabrics and linoleum and as edible oil in some areas.

Linseed cake is a very good manure and animal feed. Dual-purpose linseed straw produces fibre of good quality. Linseed is also used in making paper and plastics. That is why it is also known as plastic crop. Flaxseed is a common ingredient within many different home remedies, as it is a powerful herb used to help promote healthy digestion as well as reduce high cholesterol and heart disease.

In Chhattisgarh, linseed is cultivated over 64.08 thousand hectare area with a production of thousand tonnes and productivity of 284 kg/ha. Maximum area of this crop is grown

<sup>14</sup> Asstt.Professor(sonalideoleigkv@yahoo.com)

<sup>2,3</sup> Asstt.Professor

as 'utera' during rabi season. The important linseed growing districts of Chhattisgarh are Rajnandgaon, Durg, Bilaspur, Kabirdham, Raipur, Dhamtari, Surguja, Kanker and Raigarh (Krishi Darshika, 2014).

Linseed crop is attacked by number of insect pests at various phases of its growth. Linseed bud fly (*Dasyneura lini*) with 88 percent grain yield losses followed by Thrips (*Caliothrips incicus*), jassid (*Amrasca* sp.), semilooper (*Plusia orichalsia* Fab) and linseed caterpillar *Spodoptera exigua* Hub. Mallik et al. (2000)

Adult of linseed budfly is a small orange coloured fly. Its tiny pinkish maggots feed on the developing buds. The infested buds become hollow and can be easily identified from the healthy buds. Chemical insecticides have been recommended for the effective control of bud fly incidence in linseed. However, there are serious residual problems and ecological consequences of the insecticides. The need to phase out the use of chemical pesticides is now being felt and the use of plant products of plant protection are catching momentum of late.

Plant products derived from neem *Azadirachta indica* A.Juss. contain biologically active components that may act as toxicant, repellent, antifeedant and growth disrupting substance on insect pests and are not only ecologically safe but also free from residual problems (Gujar, 1992) All the parts of neem like seed, seed coat, kernel and leaf can be used to produce high quality product. Product derived from neem tree also act as powerful Insect Growth Regulator (IGR) (Subbalakshmi et al, 2012). Keeping these facts in view, studies on the efficacy of neem products against the bud fly in linseed crop were undertaken.

## II. MATERIAL AND METHODS

A study was conducted in the rabi season 2009-10 to evaluate the neem based formulation at farm of IGKV, Raipur, Chhattisgarh under randomized block design with ten treatments (including control), replicated thrice. Plot size was kept 5x4 m<sup>2</sup> and distance from row to row and plant to plant were maintained at 30 cm and 8-10 cm, respectively. Linseed variety 'Neelum' was sown in November month. The treatments were applied twice at fortnightly interval starting from bud initiation stage. For Bud infestation was recorded at dough stage on ten plants per plot was recorded randomly and counts of infested and total buds were noted. The data on percent bud infestation recorded were

transformed to arc sine. At harvest, seed yield per plot was also recorded and converted in kg per hectare.

**Table-1 Following neem based formulations tested against *Dasyneura lini* on linseed**

S.No.	Name of treatment
1	Neem leaf extract @2%,
2	Neem leaf extract @5%
3	Neem seed kernel extract @2%,
4	Neem seed kernel extract @5%,
5	Neem seed extract @2%
6	Neem seed extract @5%
7	Neem seed coat extract @2%
8	Neem seed coat extract @ 5%
9	Nimboline @0.5%.
10	Untreated control.

**The formulations were prepared by following method.**

- 1. Neem leaf extract** –Extracted the pure juice of fresh neem leaves by crushing and squeezing them.
- 2. Neem seed kernel extract-** Neem seed kernels were soaked in water on weight basis before 72 hours of application.
- 3. Neem seed extract-** Whole neem seeds were soaked in water on weight basis before 72 hours of application.
- 4. Neem seed coat extract-** Only neem seeds coat was soaked in water on weight basis before 72 hours of application.

All extracts were filtered with the help of fine muslin cloth before spraying.

**III. RESULTS AND DISCUSSION**

All the neem plant product formulations including the commercial product significantly reduced the per cent incidence of bud fly.

**Bud fly infestation**

Bud fly infestation ranges from 19.2 to 26.7 percent in different Neem based formulations as against 32.6 percent bud damage in untreated control. NSKE 5% with bud infestation of 19.2 percent was most effective against budfly. followed by Neem Seed Coat Extract (NSCE) @ 2%,with 20.8 percent bud infestation. Neem leaf extract 2 percent with highest bud damage of 26.7 percent was least effective against bud fly among Neem based formulations as against 32.6 percent bud damage in untreated control.

**Effect on grain yield**

The data on grain yield indicated that NSKE when applied at 5% was most effective against bud fly with highest grain yield of 838 kg/ha. It was significantly followed by Neem seed extract (NSE) 2% with grain yield 790 Kg/ha. The latter was at par with Neem seed extract (NSE) 5% and Neem seed coat extract (NSCE) 2 % with 778 and 763 Kg/ha respectively. Hence, as an

alternative strategy to synthetic insecticides, neem based insecticides are gaining greater attention and popularity worldwide owing to their biodegradability and bio safety to non target pests is concerned. While testing the neem products against *D.lini* Gupta *et al.* (2000) recorded highest grain yield and maximum net profit with neem oil 0.1% followed by neem oil 0.5%.

While testing the bioefficacy of different neem products against linseed bud fly at Faizabad, Ali (2002) found that NSKE performed better than other botanicals. He further reported that neem based insecticides were significantly superior in reducing the incidence of *D.lini* and enhancing the seed yield. Similar finding was reported by Humayun (2008) that NSKE @ 5 per cent when applied twice at 15 days interval starting with bud initiation stage was most effective against linseed bud fly with the lowest bud damage of 14.15 per cent and the highest grain yield of 1309.325 kg/ha and maximum net profit of Rs. 11106.6. Prasad and Prasad (2003) also reported 6.48 percent minimum damage by linseed bud fly and 1.96 percent damage by capsule borer and maximum yield of 1288.06 kg/ha and net monetary return of Rs. 9467/ha at Ranchi when the crop was sprayed five times at ten days interval with NSKE 5 percent.

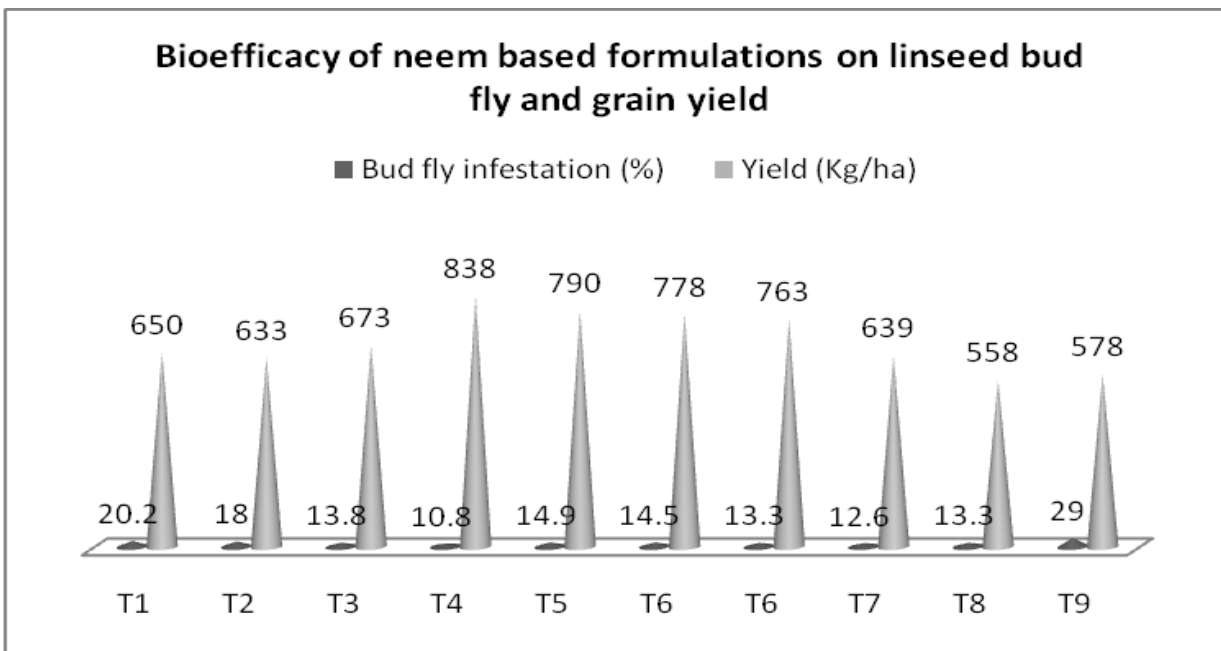
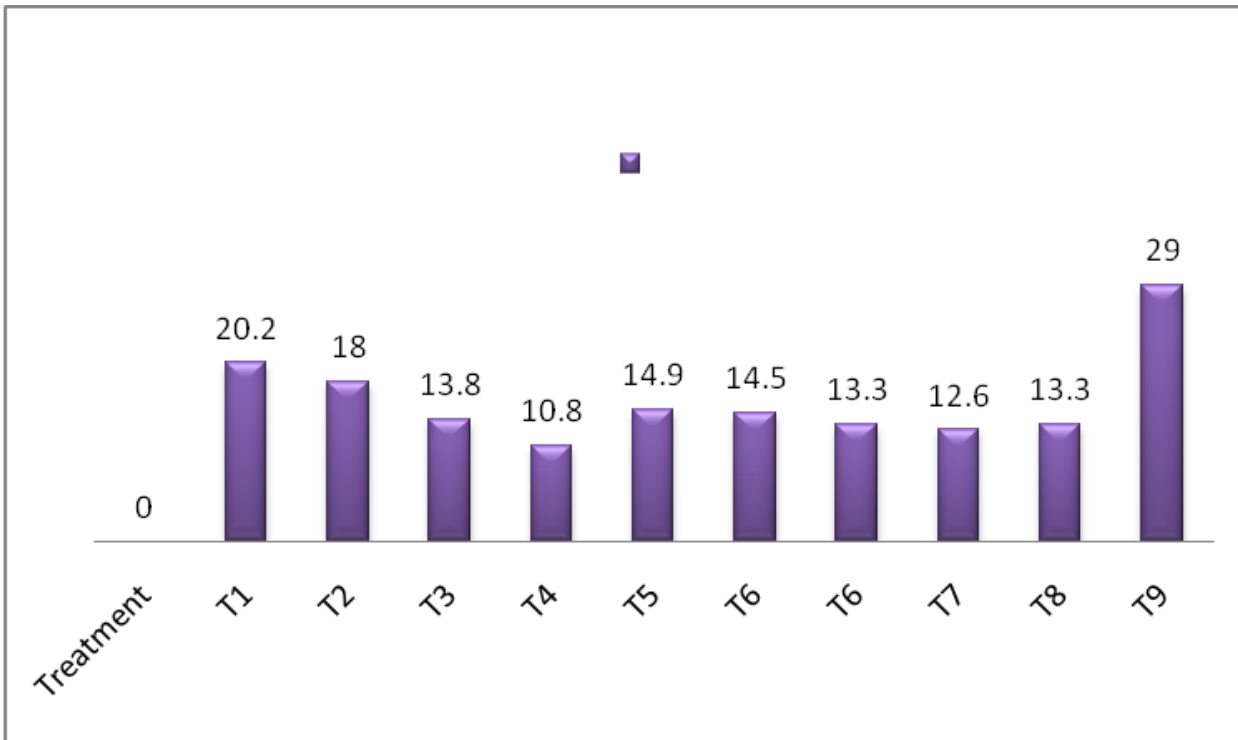
Gupta and Rawat(2004) reported reduction in the incidence of *D.lini* and increase in the grain yield with increase in the concentration of neem leaf extract, NSKE and neem oil.

**Table-2: - Performance of Neem based formulations against bud fly infestation percentage and grain yield in linseed crop**

Treatment	Name of treatment	Bud fly infestation (%)	Yield (Kg/ha)
T1	Neem leaf extract 2%,	20.2(26.7)	650
T2	Neem leaf extract 5%	18.0(25.1)	633
T3	Neem seed kernel extract 2%,	13.8(21.8)	673
T4	Neem seed kernel extract 5%,	10.8(19.2)	838
T5	Neem seed extract 2%	14.9(22.7)	790
T6	Neem seed extract 5%	14.5(22.4)	778
T7	Neem seed coat extract 2%	13.3(21.4)	763
T8	Neem seed coat extract 5%	12.6(20.8)	639
T9	Nimboline 0.5%.	13.3(21.4)	558
T10	Untreated control	29.0(32.6)	578
SE(m)±		0.46	24.8
CD (at 5%)		1.36	73.7

Values in parenthesis are transformed value

**Performance of Neem based formulations against bud fly infestation percentage**





#### ACKNOWLEDGEMENT

The authors are grateful to the PC Unit Kanpur and IGKV, All India Crop Research Project in linseed, Raipur (C.G.) for providing necessary facilities in conducting field trials.

#### REFERENCES

- [1] Ali,S.,Kumar,R. and Rizvi,S.M.A.2002.Bioefficacy of Neem products against linseed bud fly (*Dasyneura lini* Barnes) Shaspa. 9(2) :175-177
- [2] Gujar, G.T. 1992. Neem (*Azadirachta indica* A. Juss) a natural insecticide; status and need for bioassay standards.Pesticide Research. 4: 69-79.
- [3] Gupta, M.P., Chaurasia, S.K. and Rai, H.S.2000.Efficacy of neem products against the bud fly( *Dasyneura lini* Barnes) on linseed . Ind.J.Agril.Sci.70(11):762-764
- [4] Gupta,M.P. and Rawat, G.S.2004. Evaluation of neem products and their admixtures with insecticides against bud fly incidence in linseed.Annals Plant Prot. Sci.12(1) :1-4
- [5] Humayun, S.A. 2008. Studies on seasonal incidence of key pests of linseed and management strategies for linseed bud fly, *Dasyneura lini* Barnes (Diptera: Cecidomyiidae) at Raipur, M. Sc. (Ag) thesis submitted to Deptt. Of Entomology, COA, IGKV, Raipur (C.G).
- [6] Krishi Darshika. 2014. Indira Gandhi krishi vishwavidyalaya Raipur (C.G.) pp.4
- [7] Malik, Y. P., Hussain, K., Singh, S.V. and Srivastava,R.L. 2000. Development of management module for bud fly, *Dasyneura lini* in linseed Indian. J. Ent. 62 (3): 260-269.
- [8] Mukherji, K. G., Dubey, O. P. and Upadhyaya, R. 1999. Insect pests of linseed - IPM system in agriculture: Oilseed crops.Aditya Book Pvt. Ltd. pp.250-263.
- [9] Prasad, R. 2003. Field efficacy of neem based insecticides against major insect pests of linseed. Proceedings of the national symposium on frontier areas of Entomological Research, 5-7 November, 2003. pp: 325

- [10] Subbalakshmi Lokanadhan, Muthukrishnan, P. and Jeyaraman,S. 2012. Neem products and their agricultural applications. Journal of Biopesticides 5: 72-76.

#### AUTHORS

**First Author** – S. DEOLE, Asstt. Professor (sonalideoleigkv@yahoo.com), Department of Entomology, College of Agriculture, Indira Gandhi Krishi Vishwavidyalaya, Raipur, Chhattisgarh, India-492012  
**Second Author** – GUPTA, A. K., Asstt.Professor, Department of Entomology, College of Agriculture, Indira Gandhi Krishi Vishwavidyalaya, Raipur, Chhattisgarh, India-492012  
**Third Author** – D. DASH., Asstt.Professor, Department of Agricultural Microbiology, College of Agriculture, Indira Gandhi Krishi Vishwavidyalaya, Raipur, Chhattisgarh, India-492012



# Audience Perception of the Credibility of Local News Channels

Mr. H.Naresh Rao and Dr. B.K Ravi

Department of Communication, Bangalore University, Bangalore (India)

**Abstract-** People get most of their news from television news channels. India has the unique feature of having news channels in English and in regional languages. Due to the cosmopolitan nature of the cities like Bangalore, there are news channels which are in English and Kannada broadcasting 24 hour news from the city. Common sense tells us that locally produced news and in the language of the people will have credibility as opposed to news coming from Delhi or Mumbai. Many studies have established this hypothesis that television news audience believes in local channels more than the so-called national networks. Credibility factor depends on a nine dimension credibility measuring scale. The researchers would like to find out if this hypothesis is right and the reasons for the same. For this a combination of audience perception study using a questionnaire would be conducted along with in-depth interviews with the programming heads of the local news channels.

**Index Terms-** Credibility, local news channels, 24x7 news channels, online news, newspapers

## I. INTRODUCTION

News is everywhere. One can access news through newspaper, radio, television or the internet. In this changed scenario one would not be wrong in doubting the veracity of news- source becomes an important variable in both the method of access and the credibility of the news. With so many choices at hand, source credibility is the most important consideration behind the believability of news. We have come across comments like, "If it is on *BBC* it should be true". *Reuters*, for example, one of the oldest news agencies in the world puts a lot of value in verifying news before supplying it to news organizations around the world. It would not mind being overtaken by a competitor if it means it safeguards its credibility. No wonder, news organizations and people generally put a lot of trust in the news supplied by *Reuters*. The brand *Reuters* took a while to establish but losing it would just take one false story.

India has seen a proliferation of television news channels. Initially it was slow- after the government took the monumental decision to open the broadcast media to private and foreign players. The first ten years was mainly trial and error- slow and sometimes jerky start gave way to consolidation. The initial takeoff in Hindi and the regional language channels finally culminated in the establishment of an English news channel in the form of *Star News* in 1998. But it was some years later that it became a 24 hour news channel. Other English news channels started mostly from Delhi and were national in character; the only exception being *Times Now* from Mumbai. Some regional

English channels came up- a few were successful but many either closed down or have turned into multi-lingual for survival.

*Aaj Tak* had a pre-history in the sense that the *India Today* Group's first foray into television had come as early as 1988 in the form of the monthly video magazine *Newstrack*. Instead of directly launching a channel, the group used *Doordarshan* to piggy-back on to larger ventures. The group began with *Aaj Tak* (till date), a 20-minute daily news bulletin that started in 1995. It was so successful that it gave rise to a series of copy-cat programmes on *Doordarshan* like *Saptahik Aaj Tak* and *Business Aaj Tak*. *Newstrack* transformed into a weekly programme for the Metro channel and in 1998 was telecast for a year on *Star TV* before folding up.

The *Aaj Tak* group later moved into the slot vacated by *NDTV* and produced the network's live coverage of the vote count in the national elections of 1998 and 1999. The 1998 coverage was a non-stop live programme on *Doordarshan* for 72 hours while the one in 1999 lasted a full 45 hours. *Aaj Tak*, the programme, succeeded to the extent that it convinced Arun Purie to convert it into *Aaj Tak*, the channel.

After its negotiations with *CNN* for a collaborative news channel in India broke down, Purie decided to go it alone- India's first stand-alone private news channel *Aaj Tak* was built on a low-cost, high-technology model. It was the first channel in India, and possibly in the world to have a complete newsroom automation system. This meant that all editing operations were conducted on non-linear systems, which was a great advantage for faster production. The tremendous rate of obsolescence of technology also brought down studio and equipment cost drastically. *TV Today* invested in small Panasonic cameras costing \$4,000-\$5000 each compared with Sony cameras that *NDTV* had invested in, costing roughly \$20,000- \$25,000 each. This low cost of investment in hardware was a significant factor in its success.

The other innovation that *Aaj Tak* introduced was mobile outside broadcast (OB) vans. Other channels had fixed V-SAT facilities at their bureaus across the country for live coverage; they did not have the ability to regularly produce live broadcasts outside the studio on short notice. *Aaj Tak* invested Rs. 36 million on two initial OB vans that could broadcast live to a satellite within 15 minutes of reaching the location.

The above reasons allowed *Aaj Tak* to break even on its initial investment within a year of its launch and become the leader in news market, a position it retains till date. Some credit its success to the aggressive use of Khari Boli, the language of the Hindi heartland, others to the live element in its broadcast.

The English news media is considered to wield disproportionate power over the government at the center and its



policies. The likes of *The Indian Express* and *The Hindu* are today part of myth for having taken on the government and succeeded in either directly or indirectly ousting them from power. The power seems to have shifted today to the 24x7 English news channels. The four big and popular channels- *NDTV 24x7*, *CNN-IBN*, *Times Now* and *Headlines Today* exert huge amount of influence on the government of the day. The way these channels covered the CWG and 2G Spectrum scandals among others has put the government on the back foot and led to many changes. It seems the government cannot ignore the warnings of the channels and is seen to be moving very fast to comply with the 'will of the people' as represented by the news channels.

*Udaya TV* was the first Kannada satellite channel to go on air in Karnataka in 1994. The entry of *TV 9* owned by Ravi Prakash of *Sneha Television Network* in 2006 opened a new chapter in the field of Kannada news channels with its aggressive journalism. *Kasturi News 24* owned by Anita Kumaraswamy (wife of former CM H D Kumaraswamy) with its tagline 'muktha, nirbheetha and nyayasammatha' entered the field in 2007. *Suvarna News 24X7* owned by MP and businessman Rajeev Chandrashekar came in 2008 followed by *Samaya TV* owned by the then Industries Minister Murugesh Nirani in 2010. *Janashri* entered the already crowded scene in 2011 and is owned by Gali Janardhana Reddy, though there are rumours doing the rounds that the channel has changed the hands.

*Public TV*, which went live on February 12, 2012, and the other Kannada news channels are now competing and combating with one another to climb to the top with 'breaking news' of every possible kind. Everyone is waiting with baited breath to know whether Ranganth's name alone will suffice for the general public to sit up and take notice of *Public TV* and thus threaten the domination of *TV9*. Crime, sex, scandals, sensationalism and political voyeurism and breaking news apart from ordinary events and happenings are the fodder on which these channels survive.

The credibility of Kannada television is seriously at stake. Kannada television is willy-nilly turning viewers into Peeping Toms. In their quest for eyeballs and TRPs, the local channels have been feeding viewers with a diet of gossip, crime, sleaze, stings and low-brow humour. It is not uncommon for journalists to lay their hands on documents or information that relate to people's private lives. But just because they get access to a divorce petition involving an actor, they simply cannot broadcast its contents to the whole wide world.

This brings out a pertinent question: How credible are these news channels and do the viewers believe what they hear and see? The perception of the viewers about the credibility of news organizations is important in evaluating its importance for the readers and viewers and at the same time the influence or power it exerts on the power structure in the country.

A study is the only way one can get answers to the question of people's trust in media today. It is not easy for any media organization to fool the people for a long time as it is possible to verify the news from other sources. At the same time people trust one news organization over the rest on the basis of many real and perceived criteria. For example, *The Hindu* as a national newspaper has overwhelming trust among the reading population, even among those who subscribe and read other

newspapers. This is something that did not happen overnight. The newspaper in question had to build this credibility slowly over the last hundred years. When *The Hindu* during the debate on 'The Indo-US civil nuclear bill' took a differing stance and attacked the government for selling out to the United States, everyone sat up and took notice. Its credibility went up further as people realized that its stand was purely influenced by national considerations and political in nature.

Newspapers have been around for many decades but the news channels in the private sector are less than a decade old. Some like *Times Now* and *CNN-IBN* just completed six years of existence. *NDTV 24x7* has a twenty-five year history but as distinct 24-hour news channel it is just 8 years old. This poses a dilemma- how one can jump to the conclusion that one television channel is more credible than the rest. A audience study is the only way to answer this and related questions.

Many polls suggest that credibility of media- newspapers and television news channels- is declining. One of the reasons attributed is the concentration of media in the hands of big corporations like *News Corp*. The dwindling variety in the content is directly proportionate to the declining credibility people perceive in media in the current scenario. This will only get worse as there is a clamour for big media with its advantage of economies of scale.

Today, we have access to an almost inconceivably vast amount of information, from sources that are increasingly portable, accessible, and interactive. The Internet and the explosion of digital media content have made more information available from more sources to more people than at any other time in human history. This brings an infinite number of opportunities for learning, social connection, and entertainment. But at the same time, the origin of information, its quality, and its veracity are often difficult to assess. This volume of information addresses the issue of credibility—the objective and subjective components that make information believable—in the contemporary media environment.

According to *Wikipedia*, credibility has two key components: trustworthiness and expertise, which both have objective and subjective components. Trustworthiness is based more on subjective factors, but can include objective measurements such as established reliability. Expertise can be similarly subjectively perceived, but also includes relatively objective characteristics of the source or message.

Source credibility is the believability of a communicator, as perceived by the recipient of the message. Academic studies of this topic began in the 20th century and were given a special emphasis during World War II, when the US government sought to use propaganda to influence public opinion in support of the war effort. Psychologist Carl Hovland and his colleagues worked at the War Department upon this during the 1940s and then continued experimental studies at Yale University. They built upon the work of researchers in the first half of the 20th century who had developed a *Source-Message-Channel-Receiver* model of communication and, with Muzafer Sherif, developed this as part of their theories of persuasion and social judgement.

If the saga of the Indian media in the last 20-30 years is a story of great commercial success, it also chronicles the decline in journalistic standards down the line. Media has gained importance as an industry which is now one and a half percent of

GDP. We have some 350 plus news channels running in the country, but most of them are not making money. It is only the top ones in the ladder who are making money equivalent to media channels in the West.

## II. REVIEW OF LITERATURE

The exposes contained in the taped telephone conversations of corporate lobbyist Nira Radia have dented the credibility of leading journalists and undermined the public standing of the profession (Narasimhan, Oct- Dec 2011). The recorded conversations show leading journalists promising to run political errands for Radia as she works the levers of power to influence ministry formation in the union cabinet after the 2009 general elections. The tapes also show them taking dictation from her about what to write and giving her detailed advice about how Mukesh Ambani of Reliance Industries, one of her leading clients, should fight his case in court. The conversations also have Radia ordering journalists about news placements and her boasting to others about how she got some of these worthies to do jobs for her.

The journalists named are some of the senior-most in the profession and are mostly gatekeepers of news in their publications (Vasanti, 2011). The conversations seem to suggest that these journalists were not only getting information but were, on the contrary, on very familiar terms with Nira Radia. There is no sense of distance between the work of the journalists and that of Radia, but rather, they seem to merge into one.

Subsequent to this expose, the brazen conduct of these journalists and their refusal to accept any blame has further damaged their credibility, as well as the reputation of the entire fourth estate. It has been shocking to see the manner in which the mainstream media, particularly the shrill TV news channels, have tried to blank out any discussion of this issue. This has added to popular misgivings that the media was protecting its own against public scrutiny.

Ohio University Journalism Professor Hugh Culbertson knew he had a hot topic. Editors around the country were agonizing over the use of anonymous sources, fearing they were relying on them too heavily, damaging the press' credibility in the process. Culbertson surveyed more than 200 editors.

The results: Most said competition forced them to use unnamed sources, even though 81 percent considered them inherently less believable. One-third were "unhappy to a substantial degree" with how anonymous sources were handled at their own newspapers, and editors estimated that more than half would go on record if reporters pushed harder. "They seemed to regard unnamed attribution as a crutch for lazy reporters," Culbertson says.

In *Manufacturing Consent*, Herman and Chomsky provide a systematic "propaganda model" to account for the behavior of the corporate news media in the United States (Chomsky, 2002). They preface their discussion of the propaganda model by noting their fundamental belief that the mass media "serve to mobilize support for the special interests that dominate the state and private support for the special interests that dominate the state and private activity." Although propaganda is not the sole function of the media, it is "a very important aspect of their

overall service", especially "in a world of concentrated wealth and major conflicts of class interest".

The credibility and legitimacy of the media system is also preserved by the media's lack of complete agreement on all issues. Indeed, there is vigorous debate and dispute over many issues, as Herman and Chomsky readily acknowledge. They contend, however, that debate within the dominant media is limited to "responsible" opinions acceptable to some segment of the elite. On issues where the elite are in general consensus, the media will always toe the line. No dissent will then be countenanced, let alone acknowledged, except, when necessary for ridicule or derision.

Bandwagon theory is cited as a possible explanation by researchers while understanding the perception of audience in news selection (Sundar & Nass, 2001). Chaiken (1987) argued that people use the heuristic that, if many think an opinion is valid, the opinion is probably correct. Accordingly, they could just follow the evaluations and choices made by others, thereby limiting their own cognitive selection efforts. Affiliation motives may be another reason for bandwagon effect, even when relating to strangers (Byrne, 1961).

The perceptions audience members form regarding television news content has long been of interest to communication researchers. Perceptions of credibility have been found to be influenced by the content of the news reports (Austin & Dong, 1994) and characteristics of the news anchor (Markham, 1968), suggesting that perceptions of credibility may be influenced by presentation variables. The use of high-definition (HD) television may be one such variable.

One of the most important findings of this study is that perceptions of credibility can be influenced by the formal features of television. This suggests that credibility is not just an inherent quality of the source or person delivering a message. In a study conducted in Slovenia among journalists, majority of the respondents wrote that they rated the traditional news media as more credible because of their longer tradition during which they had earned a *reputation* of credibility and quality (Steensen, 2011). Some of them referred to the traditional news media's "good name" which they had achieved during years of practicing journalism. Most of them attributed such a reputation to personal "positive experiences" which they had as audience members or as journalists in their everyday practice and relations with the traditional news media, while they had negative, few, or no experiences with the online news media. Several respondents attributed the media's reputation to *personalities* who work in particular media, stating that credibility is linked to "good", "experienced", "acknowledged", "distinguished" reporters and editors. They chose the traditional news media because they employ reporters and editors whom they trust. The third key reason for rating the traditional news media as more credible is their quality *news supply*. Most respondents said that the traditional news media are more credible because they offer more "serious", "public affairs" topics, while the online news media offer more sensational news. They defined topics such as politics, economy, social affairs, and ecology as "public affairs" and listed entertainment, and especially lifestyle and sexual advice as sensational news. According to respondents, the traditional news media are more trustworthy because they offer more "exhaustive", "in-depth"

and “accurate” information, while the online news media offer “surface”, “quick” and “unverified” information. Thus, the work of journalists from the online news media is less highly rated than the work of those from the traditional news media; the main argument is that journalists from the traditional news media have a more professional journalistic approach to news production. Some respondents even wrote that they value journalism in the traditional news media more because their journalists more clearly separate facts from opinions. They also criticised journalistic writing in the online news media, arguing that online journalists construct sentences which are too short, use superficial language and make spelling and grammar mistakes. The fourth reason for rating the traditional news media as more credible was journalists’ *education* and *experiences*. According to respondents, journalists working in the traditional news media are more educated and experienced than online journalists.

The respondents who favoured the online news media mostly referred to their *promptness* at information gathering, which is very important in the contemporary fast-changing world. Some of them argued that online news media are credible because Internet users are given an opportunity to comment on published information. Thus, the *community of recipients* constantly verifies the credibility of a particular news item, the journalist who has written it, and the medium itself. The recipients who are active regularly verify credibility in this way; therefore, according to some respondents, the online news media are much more credible and of a higher quality than the traditional news media which hide behind their inaccessibility.

A TAM study after two Telugu news channels were launched showed a marked increase in the time spent on the Telugu news at the cost of Hindi news whereas the time spent on English news was more or less same (Regional news channels living up to their promise in AP, 2004). The inference here is to the preference of local news channels to national (read Hindi) ones.

In a similar finding, regional news channels were able to increase their viewership base whereas that of English and Hindi declined (Sarkar, 2011). The proliferation of regional language news channels, specially in the south, means that many viewers now have a choice and the affinity to mother tongue seems to have worked in their favour. But the biggest concern is the clamour among the national English and Hindi news channels to win back viewers with sensational coverage. As news media is dependent on big news stories, the years 2009-2010 were dull; 2008 turned out to be good with the Mumbai Terror attacks and the drama around the passing of the Indo-US Civil Nuclear Bill.

On the question of an additional news channel in Kannada, there is a feeling that the rest give too much importance to god, temple, crime and politicians (Is there space of another Kannada news channel?, 2012). *Public TV* was launched on 12 February 2012 with veteran journalist H.R. Ranganath at the helm. His reputation as a no-nonsense Editor at *Kannada Prabha* gives hope that things will be different and balanced coverage would be the hallmark of *Public TV*. A year into the telecast, *Public TV* has done phenomenally well due to the quality and trustworthiness of the channel.

### III. METHODOLOGY

#### Design for credibility study

Survey research uses scientific sampling and questionnaire design to measure characteristics of the population with statistical precision.

A survey was conducted in which 250 respondents from all across Bangalore city were administered a questionnaire. The Questionnaire was first tested and the reliability and validity was ensured before a full scale survey was concluded. A convenience sampling technique was adopted to draw a representative sample from among the television viewing population of Bangalore city. Care was taken to ensure that all parts of Bangalore city was covered.

Many top news channel heads and senior journalists were interviewed to get a better idea of the workings on the news channels. This was also useful for designing of the questionnaire. This study intends to find if local news channels are perceived to be more credible by the viewers than national news channels and therefore believe the news on local channels more.

The main reason for the study is the rise and development of 24-hour news channels in India in the last decade and the impact it is having on the way news is gathered, processed and disseminated to an ever growing and ever hungry audience.

The following research questions will guide this study:

1. News is important for the citizens of Bangalore.
2. Traditional media sources are important for getting news.
3. Television is becoming an important source for the majority of the audience.
4. Local television channels provide credible news to Bangaloreans.
5. People tend to believe the local news channels over the national news channels.

### IV. HYPOTHESIS

Credibility of local news channels will be higher than that of the national news channels.

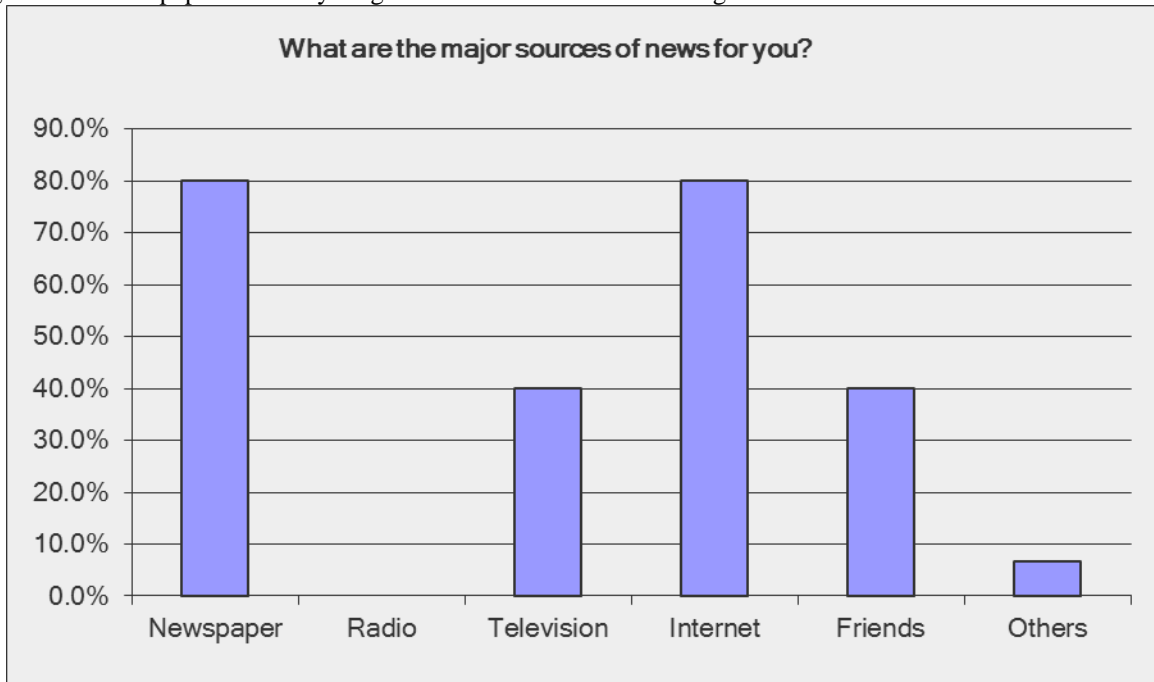
#### Data Presentation and Analysis

The survey provided the following results-

1. News is very important for the citizens of Bangalore. Newspapers are still the preferred mode of getting news for the older generation of Bangaloreans. But surprisingly the young get their daily dose of news from internet and specially online news portals and social media sites. Television is gaining but is still behind newspapers as the preferred source of news. Television is seen as an entertainment medium rather than a source for serious news. Newspaper has a high trust value among all age categories and is able to maintain its credibility due to the adage: If it is in print, it should be true. Radio, unfortunately, doesn’t have any takers as far as news is concerned- purely for music.

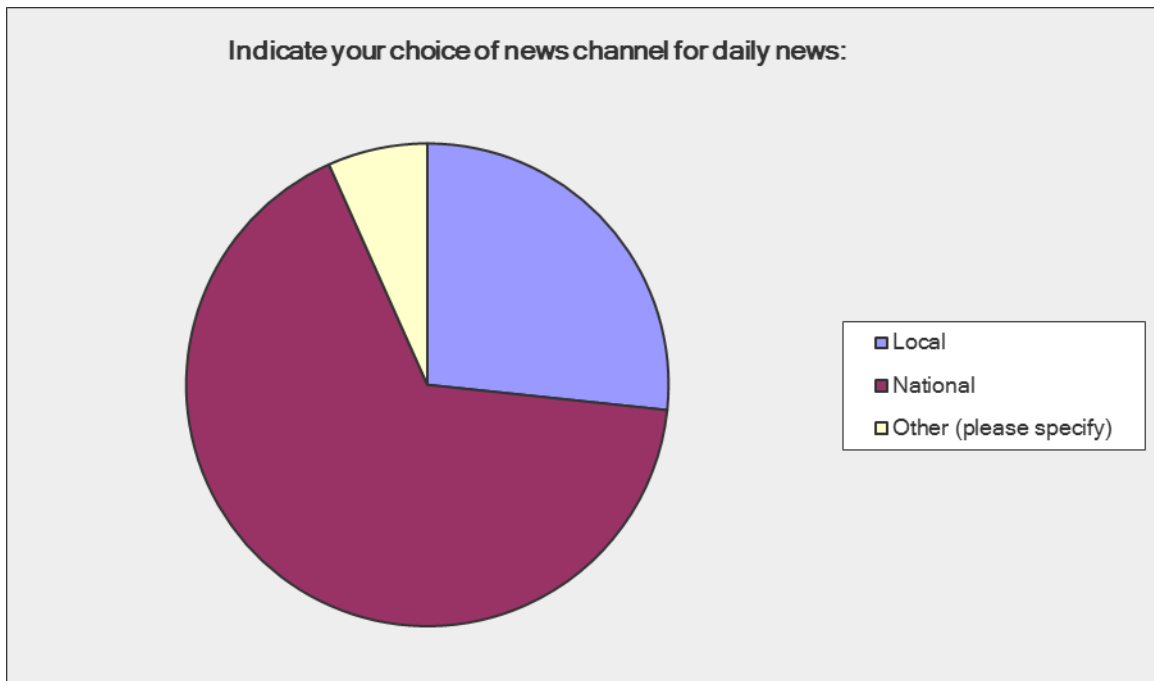
Convenience and affordability are the reasons behind newspapers’ large readership despite the inroads made by television. New media has a loyal following and in the near

future will gain over newspapers as the young out-number the old in Bangalore.



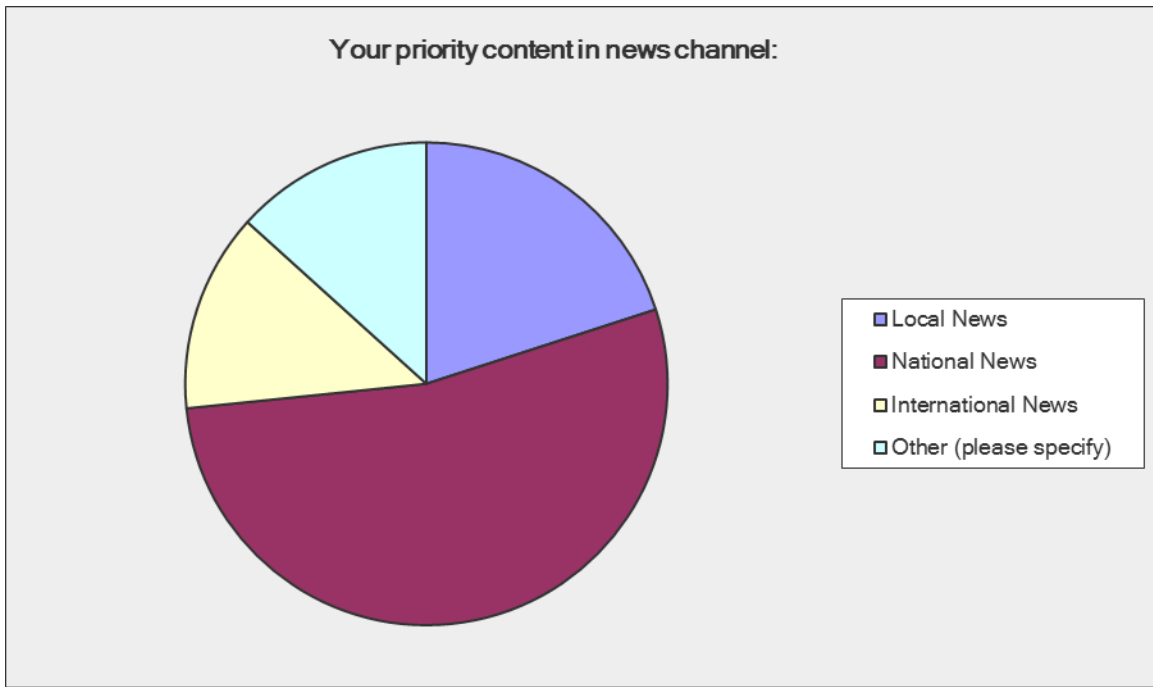
2. National news channels are preferred over local news channels for getting daily news. A huge majority of the viewers polled for this survey chose national over local news channels for getting their daily dose of news. The

cosmopolitan nature of Bangalore has a lot to do with the national outlook as opposed to the local or regional stance.



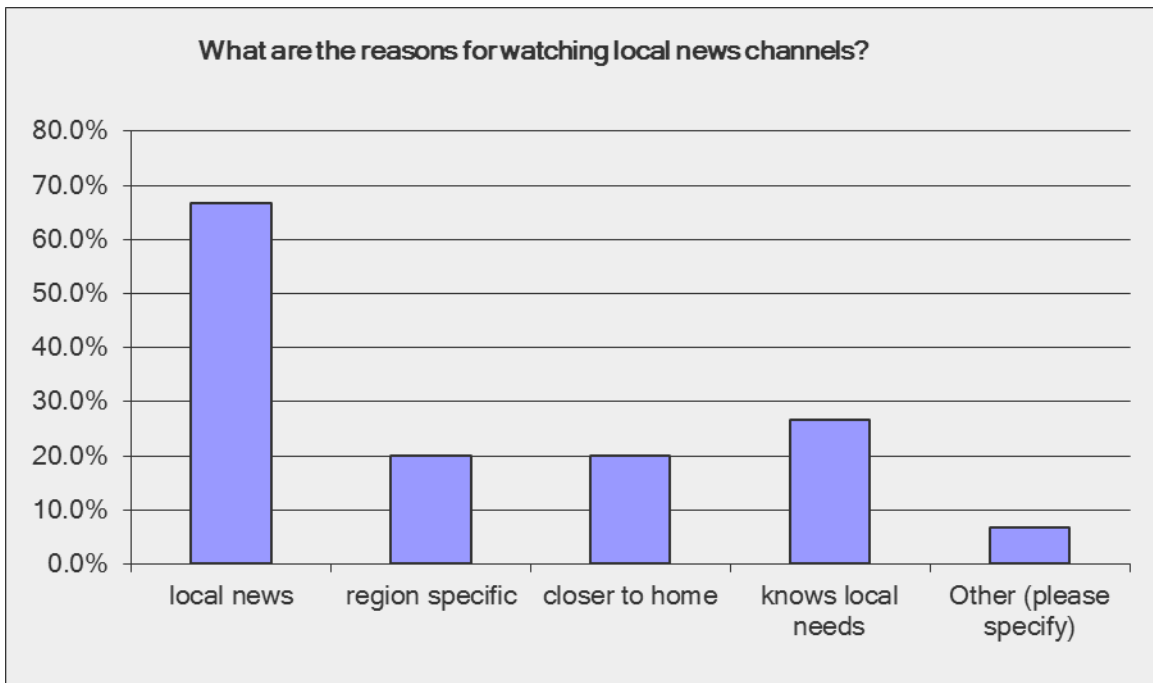
3. National news is ahead of local news the respondents like to watch. The sheer number of stories that are carried on national news channels coupled with the diverse nature of the viewer may be the reason for preferring national news, even when they are watching

local news channels. The worry that parochialism and regionalism will increase with sub-nationalistic tendencies don't bear out from this survey. In fact, pan Indian feeling is taking root among the residents of Bangalore.



4. When they were quizzed about the reasons for watching local news channels, majority spoke about the local news coverage being the main reason followed by knowledge of the local needs of the viewers. If one looks deep into this phenomenon it is clear that people

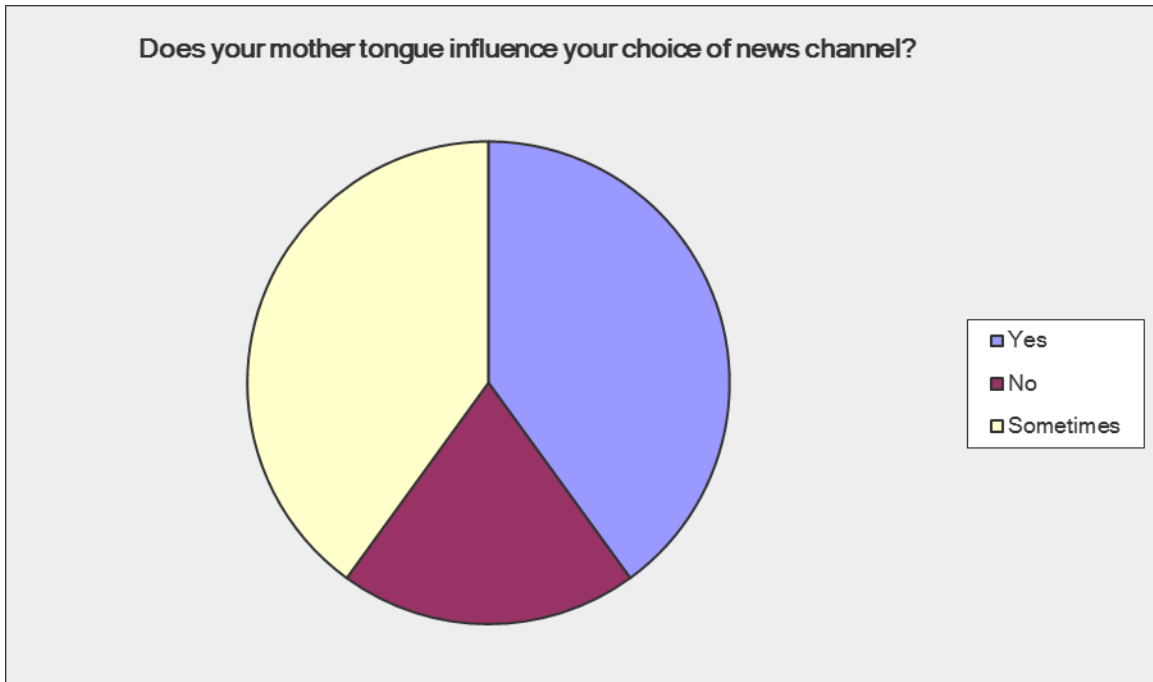
who are from different parts of the country want a bit of local news of their region in addition to the general news from around the country. They want to keep in touch with their motherland- be it Tamilnadu or Andhra Pradesh- and its goings on.



5. Mother tongue matters in the choice of local news channels. Only 30% said that it doesn't matter in their choice of news channel. One likes to watch news in the language that one is comfortable in. Hindi speakers prefer to watch Hindi news channels as Kannadigas like to watch news in Kannada channels. This give ample

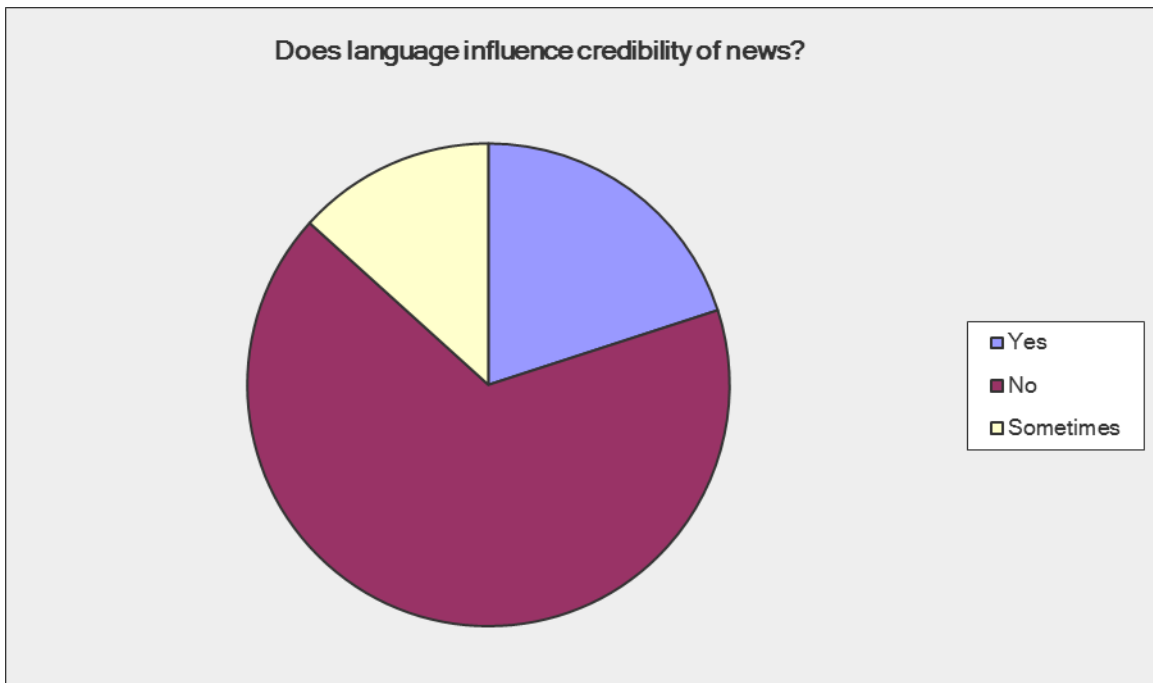
scope for news channels in all languages. English doesn't have a monopoly, so is the case with Hindi or Kannada for that matter. The more cosmopolitan one gets, the preference shifts to English news channels from local ones. Bangalore is one of the three cosmopolitan cities in India; Delhi and Mumbai being the other two.





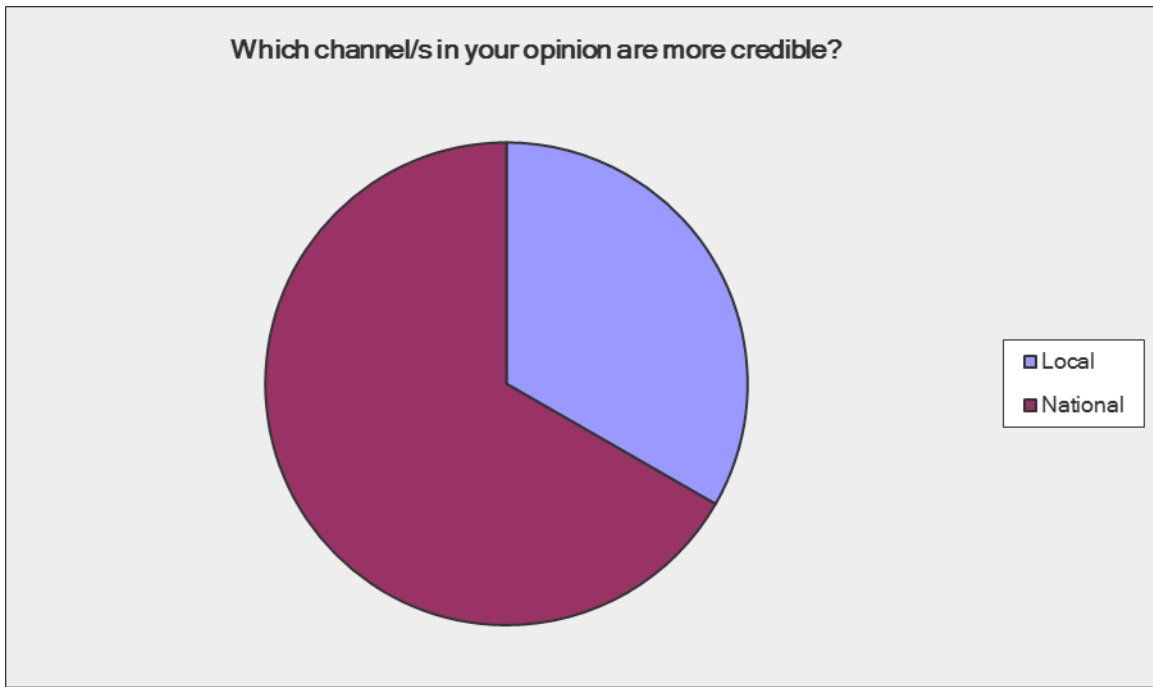
6. But surprisingly language was not instrumental in linking the news channels to the credibility. Majority felt that credibility has very little to do with which language the channel is in. What is more important is

the way the news is presented and dealt with by the news channels- sober and sticking to facts.



7. Majority felt that national and not local news channels are more credible. Even though many watch regional language news channels they attribute less trust to them as compared to national news channels. This is very surprising as it breaks the myth that people attribute

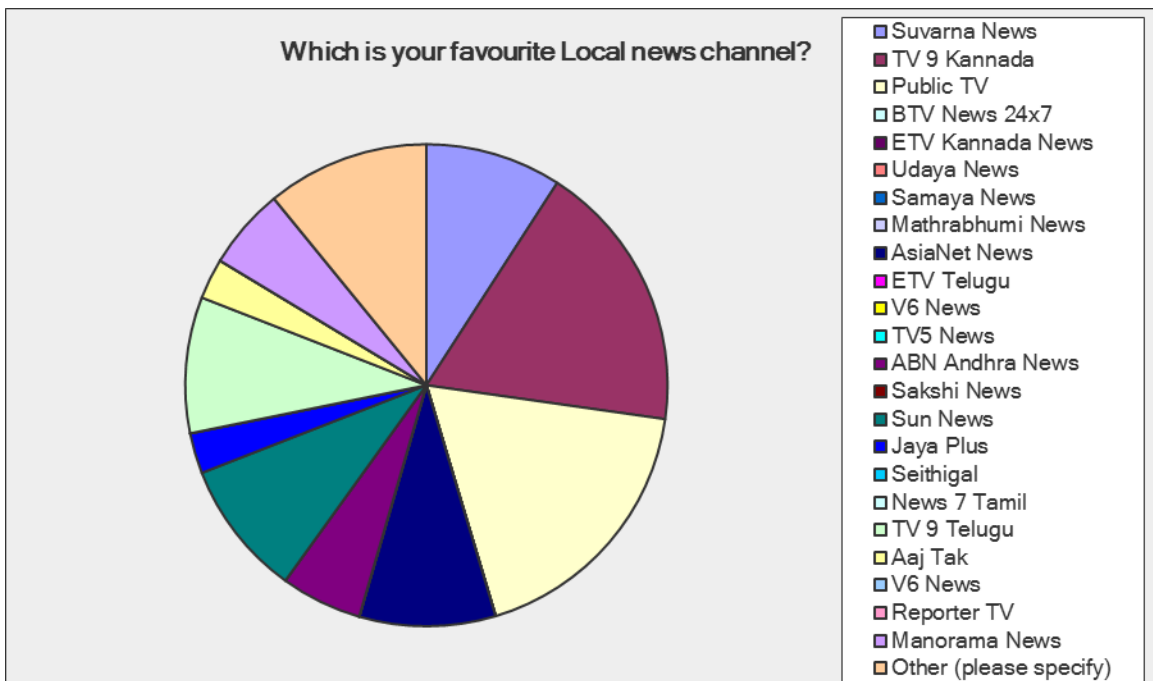
trust to their language and a television news channel in their mother tongue is much more credible. English national news channels for all their flaws get thumbs up from the viewers in Bangalore.



8. As is well known *TV9 Kannada* has the highest rating among the Kannada news viewing audience. But *Public TV* has caught up with *TV9* and as things stand it may very well become the number one Kannada news channel in days to come. Some of the news channels in Kannada have fallen in popularity and are struggling to find viewers. This may be due to the staleness of their presentation and the strategies of the top two channels to go all out to woo the audience with sensational and loud content. The view of the people of Bangalore is mixed as far as credibility of local news channels is concerned. They feel that some channels are more

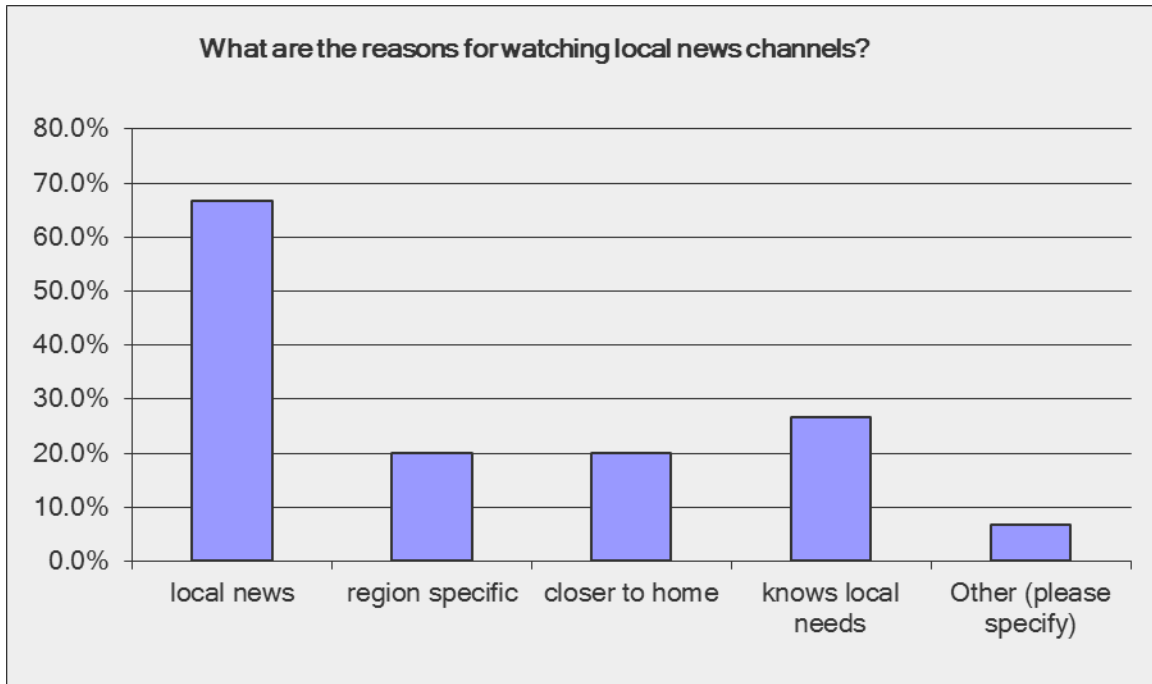
credible than others due to the ownership and reputation of the editor in chief. The reason given in case of *Public TV* is the apolitical ownership and the reputation of the editor as being no-nonsense person.

9. As Bangalore is a cosmopolitan city, people watch television news in many languages. Kannada and English news channels have equal number of viewers, followed by Hindi and Telugu. It more or less goes with the demography of Bangalore which is highly diverse in the way the people belonging to different languages are spread across the city.



10. There are multiple reasons for people to prefer local channels. In addition to the language preference there seems to be the issue of coverage and relevance. Local news channels give extensive coverage to local and regional stories and issues that are close to the citizens of Bangalore. The cosmopolitan nature of Bangalore is to some extent responsible for a sizable percentage

opting for national news channels over local ones. People who are from outside of the state end up watching either English, if they are from a higher socio-economic background or Hindi, if they are the typical middle-class from north of the Vindhya's.

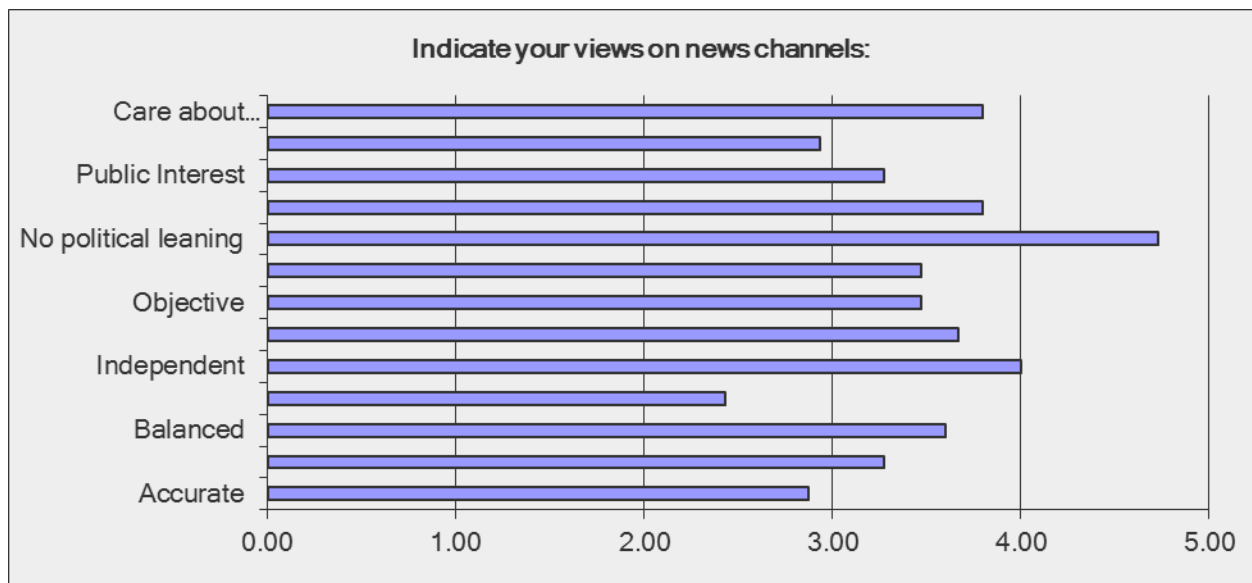


11. The most important finding of this study would be the correlation between the cosmopolitan nature of the news viewers and the preference for English news channels. English is still considered to be the language for upward mobility in India. From speaking English at home to communicating in the colonial language at work, people perceive English language to have the ability to put them on-par with the so-called elite in society. That is precisely the reason why a large percentage of the respondents preferred national channels, English at that.

12. Regional news channels can flourish in India and in particular in Bangalore for the reason that the nature of society is fast undergoing rapid changes. The economic imperative that have been unleashed a little over two decades back is coming home to roost. Demographically Indian cities are changing from being the preferred destination of locals- people in the neighbourhood- to migrants from near and far. With most Indian languages

spoken in tier 1 and tier 2 cities, the media scene is reflecting this new reality. Gone are the days when one language could be imposed on the entire population of India in the name of National Integration and nation building was the sole object. Today, regional aspirations are getting translated into news channels that cater to niche language demands of an ever prosperous populous.

13. Finally, what this survey provides is the data that proves that local news channels are perceived as being less credible than the national news channels. This perception is based on the fact that language news channels indulge in far more sensational and trivia news content than national channels. The more the competition the depths to which a channels will stoop to conquer the viewership heights. Very few people feel that local news channels provide accurate, balanced and objective news.



### V. CONCLUSION

In 1995 when the Hindi news channel *Aaj Tak* was launched, there was a belief that like *Doordarshan* for over three decades, private channels will also cater to a national (Hindi) speaking audience. But soon the scene changed and in the last decade regional language news channels have flourished everywhere in India. It is not surprising given that the top five newspapers in terms of circulation and readership happen to be regional language newspapers. *The Times of India* is number eight, way behind the leaders *Danik Jagaran* (Hindi), *Malayala Manorama* (Malayalam) and *Daily Thanthi* (Tamil). The number of English language news channels is just eight and that in Hindi is a little over ten. But the largest number of news channels are in the other Indian languages- close to one hundred and growing. The saturation point for English news channels has been reached and soon Hindi will follow suit. The potential for regional language news channels in India is driven by economic realities as much as by the socio-political considerations. The true nature of India- unity in diversity- is translating into regional news hubs in virtually all states. Space for articulating and strengthening the culture that is specific to every state, and in some cases within states, is to be found in language specific television channels; more specifically news channels. Regional aspirations in the form of political agitation is finding voice in the language press (includes television). Further fragmentation of the existing news channels, specially the Indian language ones, shows the impatience of the regional aspirations trying to assert its uniqueness.

In all this the credibility factor seems to take a back seat as competition is driving the TRP wars. Everything is fine to get one more viewer to switch to your channel- ethics is confined to the text books to be taught in J-Schools and not practiced in news rooms. Its impact is obvious in the news and views on news one gets to see on news channels. The more harsh, shrill and noisy the debates on primetime news the better for TRPs, or so is the perception among the news heads. The fact that more people in cosmopolitan cities like Bangalore are switching to national news channels is a point to be noted by the decision makers in the local

news channels. But it is also true that audience for regional language news channels is increasing faster than that for English channels. Credibility depends on the culture- the practices prevalent in news rooms of television channels. Unless that changes for the better with strict code of ethics, credibility will be low. What is also lacking is a role model that begs to be emulated by others in the industry. In case of newspapers we have *The Hindu* but the beating *NDTV 24x7* took after the revelations in the Nira Radia tapes episode has left a vacuum in the broadcast news industry.

Far more cause for concern to the news channels per se is the increasing reliance on online news by the young population of Bangalore. The lack of credibility coupled with convenience may very well push a majority of viewers of news to online sources. The West, where majority get their news from digital media as opposed to newspapers or television channels, may get replicated right here in Bangalore.

### REFERENCES

- [1] Balon, R. E., Philport, J. C., & Beadle, C. F. (1978). How gender and race affect perceptions of newscasters. *Journalism Quarterly*, 55, 160-64.
- [2] Batabyal, Somnath. (2012). *Making News in India- Star News and Star Ananda*. New Delhi, India: Routledge.
- [3] Chaiken, S. (1987). The heuristic model of persuasion. In M. P. Zanna, J. M. Olson, & C. P. Hermann (Eds.), *Social influence: The Ontario symposium* (Vol. 5, pp. 3-39). Hillsdale, NJ: Lawrence Erlbaum Associates, Inc.
- [4] Chomsky, E. S. (2002). *Manufacturing consent: The political economy of the mass media*. London: Random House
- [5] Delia, Jesse G. (1976). A Constructivist Analysis of the Concept of Credibility. *Quarterly Journal of Speech*, 62:361-375.
- [6] Flanagin, A. J., & Metzger, M. J. (2000). Perceptions of Internet information credibility. *Journalism & Mass Communication Quarterly*, 77, 515-540.
- [7] Gaziano, C., & McGrath, K. (1986). Measuring the concept of credibility. *Journalism Quarterly*, 63, 451-462.
- [8] Greenberg, B. (1966). Media use and believability, some multiple correlates. *Journalism Quarterly*, 43,665-732.

- [10] Gunther, A. C. (1988). Attitude extremity and trust in media. *Journalism Quarterly*, 65, 279-287.
- [11] Hovland, D. J., & Weiss, W. (1951). The influence of source credibility on communication effectiveness. *Public Opinion Quarterly*, 15, 635-650.
- [12] Is there space for another Kannada news channel? (2012, January 25). Retrieved from kannada-
- [13] Churmuri: <http://churmuri.wordpress.com/2012/01/25/is-there-space-for-another-news-channel/>
- [14] Kioussis, S. (2001). Public trust or mistrust? Perceptions of media credibility in the information age. *Mass Communication & Society*, 4(4), 381-403.
- [15] Lu, L., & Standing, L. (1989). Communicator credibility: Trustworthiness defeats expertness. *Social Behavior and Personality*, 17, 219-221.
- [16] Mancini, Paolo. (1993). The Legitimacy Gap: A Problem of Mass Media Research in Europe and the United States. *Journal of Communication*, 43.3, 100-109.
- [17] Markham, David. (1968). The Dimension of Source Credibility of Television Newscasters. *Journal of Communication*. 18:57-64.
- [18] Meyer, Philip. (1988). Defining and Measuring Credibility of Newspapers: Developing an Index. *Journalism Quarterly* 65 : 567-74.
- [19] Mulder, R. (1980). Media credibility: A use-gratifications approach. *Journalism Quarterly* 57, 474-7.
- [20] Myers, Jerome L., and Arnold D. Well. (2003). *Research Design and Statistical Analysis*. 2nd ed. Mahwah, NJ: Lawrence Erlbaum Associates.
- [21] Narasimhan, S. (Oct. 2011). Sting operations- a lot depends on the journalist's moral sense.
- [22] Vidura, 2-8.
- [23] Newhagen J., & Nass, C. (1989). Differential criteria for evaluating credibility of newspapers and TV news. *Journalism Quarterly*, 66, 277-284.
- [24] Noto-Morgan, Arlene. (1990). Credibility: A Trust That Was Never There. *American Editor* (October 1997): 14-16.
- [25] O'Keefe, D. J. *Persuasion: Theory and research*. Newbury Park, CA: Sage.
- [26] Punathambekar, Aswin., and Shanti Kumar, eds. (2013). *Television at large in South Asia*. New Delhi, India: Routledge.
- [27] Regional news channels living up to their promise in AP. (2004, July). Retrieved from TAM
- [28] Media Research:
- [29] [http://www.tamindia.com/tamindia/NL\\_Tam/NL\\_TAM\\_RG\\_CH\\_IN\\_Andhra.htm](http://www.tamindia.com/tamindia/NL_Tam/NL_TAM_RG_CH_IN_Andhra.htm)
- [30] Rimmer, T., & Weaver, D. (1987). Different questions, different answers? Media use and media credibility. *Journalism Quarterly*, 64(1), 28-36.
- [31] Rosenthal, P. I. (1971). Specificity, verifiability and message credibility. *Quarterly Journal of Speech*, 57, 393-401.
- [32] Salwen, Michael B., and Don W. Stacks, eds. (1996). *An Integrated Approach to Communication Theory and Research*. Mahwah, NJ: Lawrence Erlbaum Associates.
- [33] Sarkar, A. (2011, April 28). Have news channels reached their peak? Retrieved from afaqs:
- [34] [http://www.afaqs.com/news/story/30364\\_Have-news-channels-reached-their-peak](http://www.afaqs.com/news/story/30364_Have-news-channels-reached-their-peak)
- [35] Shaw, E. (1973). Media credibility: Taking the measure of a measure. *Journalism Quarterly*, 50, 306-311.
- [36] Steensen, S. (2011). Online Journalism and the promises of new technology. *Journalism Studies*,
- [37] 311-327.
- [38] Strickland, V. S. (1980). The effects of gender, age, and gender-role attitudes on television newscaster credibility: An experimental study. (Doctoral dissertation, University of Tennessee, 1980.) *Dissertation Abstracts International*, 41, 450-451.
- [39] Sundar, S., & Nass, C. (2001). Conceptualizing sources in online news. *Journal of Communication*, 51(1), 52-72.
- [40] Vasanti, P. (2011, October). Media in India needs to be more ethical, responsible. *Vidura*, pp. 9-
- [41] 12.
- [42] Wayne Wanta and Yu-Wei Hu. (1994). The Effects of Credibility, Reliance, and Exposure on Media Agenda Setting: A Path Analysis Model. *Journalism Quarterly* 71: 90-98.
- [43] Westley, B. H., & Severin, W. J. (1964). Some correlates of media credibility. *Journalism Quarterly*, 41, 325-335.
- [44] Wilson, C. E., & Howard, D. M. (1978). Public perception of media accuracy. *Journalism Quarterly*, 55, 73-76.

#### AUTHORS

**First Author** – Mr. H. Naresh Rao, PhD scholar, Department of Communication, Bangalore University, Bangalore, India (nareshr66@yahoo.com)

**Second Author** – Dr. B. K. Ravi, Professor, Department of Communication, Bangalore University, Bangalore, India.



# Some neglected and underutilized fruit -crops in Sri Lanka

Nilanthi Dahanayake

Department of Agricultural Biology, Faculty of Agriculture, University of Ruhuna, Mapalana, Kamburupitiya, Sri Lanka.

**Abstract-** In Sri Lanka there is a high potential for cultivating fruit-crops for the domestic and export markets. Sri Lanka's per capita consumption of fruits remains far below the required average daily intake of 40g (edible portion) for a balanced diet (Research Institute MRI). The present economic growth in Sri Lanka will create a higher demand for fruits in the local market that could to be matched with higher production. Hence the Fruit Sector also has a greater potential to contribute to increase the national income, employment opportunities, and the nutrition and health status of the people. Demand for underutilized fruits and fruit-products, could be increased through awareness programs on the benefits of these products and market promotion. Although the Sri Lankan fruits have high demand in local and foreign markets. The major challenge faced by exporters is finding exportable quality fruits in sufficient quantities.

Fruits could be used to prepare various value-added products. These products are nutritious and high in fiber and antioxidants. The products are different from those of mainstream commodities - limited and seasonal availability and difficulties in harvesting/collection make these commodities/products costly. High costs, lack of awareness, and ideological aspects keep products away from diets and adversely affect underutilized fruit business. A ten-year existing venture in Sri Lanka prepares and markets a number of long shelf-life products from underutilized fruits. Limited availability and seasonality, time and labor requirements for plucking and/or cleaning, and often smaller edible portions of the fruits make final products costly. High prices prevented the sale of products in local market. Generally available commodities and products are cheaper. Nevertheless, sales of products were limited due to availability of fresh crop and ideological barriers. Many products were successful in markets such as UK, Canada, USA, Australia, and Dubai. The demand for fruit preserves and preparations is increasing yearly.

**Index Terms-** underutilized fruits, Fruit Sector, fruit preserves

## I. INTRODUCTION

Neglected and underused crops are domesticated plant species that have been used for centuries or even millennia for their food, fibre, fodder, oil or medicinal properties, but have been reduced in importance over time owing to particular supply and use constraints. These can include, *inter alia*, poor shelf life, unrecognized nutritional value, poor consumer awareness and reputational problems (famine food or "poor people's food"). Other than that, with modernization of agricultural practices

many of these crops have become neglected due to their being held in low esteem and some have been so neglected that genetic erosion of their gene pools has become so severe that they are often regarded as lost crops (Williams *et al.*, 2002). These species have to ensure food security, nutrition, health, income generation and environmental services. Sri Lanka has over 60 varieties of underutilized fruit crops. Underutilized fruit crops can be defined as fruit crops which have value but not widely grown, rarely found in the market and not cultivated commercially (Agent, 1994). A few districts lead the production of fruits at present in Sri Lanka. However it is important to note, that the statistics are still not available for newly liberated areas in the North and the East and these districts has much untapped potential to growth fruit (Table 1). The main products consumed by people are fruit cordial, jam, fruit drinks, chutney, candy, pickle and squash concentrate (Table 2). According to the corporate plan of the Ministry of Agriculture for 2011 – 2013 the objective of the Government is to improve the quality, sustainability and standards of fruit production and minimize the post harvest losses. Further the Ministry plans to increase the production of fruits over the years and also increase domestic value addition by establishing fruit processing units.

Due to the commercialization of few vegetables and other crop species the entire country is mainly depend on handful of crop species neglecting large number of vegetables, fruits and other crop species with high nutritional and medicinal values which were grown traditionally in the past, resulting these valuable crop species are critically endangered and facing the state of speedy disappearing.

Presently in Sri Lanka underutilized vegetables and other crop species face extinction or severe genetic loss, but detailed information is lacking. For most of the endangered vegetables and other crop species no conservation action has been taken. There is not even a complete inventory of these underutilized valuable plants, much of the knowledge on their use is held by traditional societies, whose very existence is now under threat. Little of this information has been recorded in a systematic manner. Besides the identification and selection of these underutilized plants for use in health services and increase the nutritional status of the people, there is the potential that these plants hold as resources bank for address the issues relating to the food security, upgrading the nutritional status of the community and socio economic development of rural communities in Sri Lanka.

## II. CONSERVATION STRATEGY

Recently to facilitate the conservation of these underutilized fruit crops. The main components are; Identification and collecting live samples of neglected and underutilized crop species found in Sri Lanka, establishment of plant arboretum for neglected and underutilized vegetables, fruits and other crop species and promote studies, research and multiplication for the benefit of future generation, conducting awareness creation and educational workshops on the medicinal and nutritional values of identified underutilized species, conducting field research and studies to identify the most suitable techniques for the growing of these plant species and introduction of identified underutilized vegetables and other crop species to the rural home gardens and facilitate the community contribution for conservation of such crop species.

### Underutilized fruit -crops in Sri Lanka

**Katuanoda (*Annona muricata*)**. It is really interesting that the recent studies have revealed that Katuanoda fruit having strong anti-cancer effects. It has been found Katuanoda having the ability to kill cancer up to 10,000 times more effectively than strong chemotherapy drugs, without harming the healthy cells. One of its cancer cure properties that has found out is 'annonacin'. Also, Katuanoda is high in carbohydrates, especially fructose and it has large amount of vitamins C, B1, and B2. Chamathka Jayawardena (2013).

**Madan (*Syzygium cumini*)** barks and seeds are used to treat diabetes and the leaf juice is used for gingivitis conditions.

**Lavalu (*Pouteria campechiana*)** fruit acts as a bulk laxative agent

**Beli (*Aegle marmelos*)** fruit contains gastro protection properties, controls diabetes, cholesterol, constipation, dysentery and diarrhea.

**Guava (*Pisidium guajava* L.)** leaves and bark are used as a disinfectant and antiseptic in dressing wounds and sores, flowers are used for treating bronchitis and the fruit helps to reduce high blood pressure. Jackfruit (*Artocarpusheterophyllus* Lam) leaves are used for curing fever and skin disease, latex of the fruit is used for treating dystopia, ophthalmities and pharyngitis while the fruit is used for overcoming the use of alcohol.

**Nelli (*Emblia officinalis*)** fruit enhances immunity and is high in antioxidants, reduces inflammation and is good for digestion.

**Pomegranate (*Punica granatum* L.)** fruit skin is used for the treatment of diarrhea and fruit juice is used for poor appetite and digestive disorders. The bark is highly toxic to intestinal worms.

**Tamarind (*Tamarindu indica*)** fruit is used for fever.

**Veralu (*Elaeocarpus serratus*)** fruits are used to treat diarrhoea.

**Woodapple (*Ferronialimonia*)** is used as a laxative and prevents and cures scurvy.

**Durian (*Durio zibethinus*)** fruits and leaf juice is used for treating fever.

**Goraka (*Garcenia zeylanica*)** fruit is considered as an amazing fat burner.

**Gaduguda (*Baccauria motieyana*)** bark is used for scorpion bites.

**Kon (*Schleichera oleosa*)** seeds are used as a hair stimulant and a cure for itching.

**Rose apple (*Zyzygium jambos*)** seeds are used for diabetes and diarrhea.

**Uguressa (*Flacourtia indica*)** leaves and roots are used for snake bites.

**Emberella (*Sondias Dulcis*)** fruits are used for high blood pressure while leaves are used to cure mouth sores.

**Palu (*Menilkara hexandra*)** fruits are used to relieve burning sensation and anorexia while the bark is used for odontopathy.

**Namnan (*Cynometra cauliflora*)** seeds are used to cure skin disease

**Lovi (*Flacourtia inermis*)**, Mandarin (*Citrus reticulata*), Nasaran (*Citrus japonica*), Pummello (*Citrus grandis*) and Sapodilla (*Achras sapato*) are also high in medicinal values (Subasinghe 2014). (Fig. 1).

### Recent trends in fruit and vegetable processing

#### New products

The number and variety of fruit and vegetable products available to the consumer has increased substantially in recent years. The fruit and vegetable industry has undoubtedly benefited from the increased recognition and emphasis on the importance of these products in a healthy diet. Traditional processing and preservation technologies such as heating, freezing and drying together with the more recent commercial introduction of chilling continue to provide the consumer with increased choice. This has been achieved by new heating (e.g. UHT, microwave, ohmic) and freezing (e.g. cryogenic) techniques combined with new packaging materials and technologies (e.g. aseptic, modified atmosphere packaging). The overall trend in new fruit and vegetable products is "added value", thus providing increased convenience to the consumer by having much greater variety of ready prepared fruit and vegetable products. These may comprise complete meals or individual components. The suitability of products and packages for microwave re-heating has been an important factor with respect to added convenience.

#### Heat processed products;

1. Canned fruits and vegetables- combination of vegetables in sauces and vegetable recipe dishes. Exotic fruits.
2. Glass packed fruits and vegetables- "Condoverde"/"antipasti" products based on vegetables in oil. - High quality fruit packs.
3. Retortable plastics- Basic vegetables or vegetable meals- Fruit in jelly
4. Aseptic cartons- Ready made jelly
5. Rosti meals - Potato based products in retort pouches
6. Fruit juices - New combinations of juices and freshly squeezed products
7. Crisps - Thick and crunch skin-on crisps. Kettle or pan fried chips. Lower fat crisps.

Source: C. Dennis (1993)

#### A fresh look at dried fruit

New fruit varieties and advance in drying technologies are putting a fresh twist on dried fruit applications. Fruits that have been introduced to the drying process include cranberries, blueberries, cherries, apples, raspberries and strawberries - not to mention the traditional mainstays of raisins, dates, apricots,

peaches, prunes and figs. Perceived as a "value-added" ingredient, dried fruit adds flavour, colour, texture and diversity with little alteration to an existing formula. The growing interest in ethnic cuisines in U.S.A. and the change to a more healthy way of eating, has also moved dried fruit considerably closer to the mainstream. Found primarily in the baking industry, dried fruit is coming into its own in various food products, including entrees, side dishes and condiments. Compotes, chutneys, rice and grain dishes, stuffings, sauces, breads, muffins, cookies, deserts, cereals and snacks are all food categories encompassing dried fruit. Since some dried fruit is sugar infused (osmotic drying), food processors can decrease the amount of sugar in formula - this is especially the case in baked products. Processors are making adjustments in moisture content of the dried fruit so that a varied range is available for different applications. An added bonus is dried fruits' shelf stability (a shelf life of at least 12 months). Dried fruit is more widely available in different forms, including whole dried, cut, diced and powders.

### **Citric acid and its use in fruit and vegetable processing**

Citric acid may be considered as "Nature's acidulant". It is found in the tissues of almost all plants and animals, as well as many yeasts and moulds. Commercially citric acid is manufactured under controlled fermentation conditions that produce citric acid as a metabolic intermediate from naturally-occurring yeasts, moulds and nutrients. The recovery process of citric acid is through crystallization from aqueous solutions. Citric acid is widely used in carbonated and still beverages, to impart a fresh-fruit "tanginess". Citric acid provides uniform acidity, and its light fruity character blends well and enhances fruit juices, resulting in improved palatability. The amount of citric acid used depends on the particular desired flavour (e.g., High-acid: lemonade; Medium-acid: orange, punch, cherry; Low-acid: strawberry, black cherry, grape). Sodium citrate is often added to beverages to mellow the tart taste of high acid concentrations. It provides a cool, distinctive smooth taste and masks any bitter aftertaste of artificial sweeteners. In addition, it serves as a buffer to stabilise the pH at the desired level. The high water solubility of citric acid (181 g/100 ml) makes it an ideal additive for fountain fruit syrups and beverages concentrates as a flavour enhancer and microbial growth inhibitor (preferably at pH < 4.6).

In processed fruits and vegetables, citric acid performs the following functions:

- a. It reduces heat-processing requirements by lowering pH: inhibition of microbial growth is a function of pH and heat treatment. Higher heat exposure and lower pH result in greater inhibition. Thus the use of citric acid to bring pH below 4.6 can reduce the heating requirements. In canned vegetables, citric acid usage is greatest in tomatoes, onions and pimentos. For tomato packs, the National Canners Association recommends a pH of 4.1 to 4.3. In general, 0.1% citric acid will reduce the pH of canned tomatoes by 0.2 pH units.
- b. Optimise flavour: citric acid is added to canned fruits to provide for adequate tartness. Recommended usage level is generally less than 0.15%.

- c. Supplement antioxidant potential: citric acid is used in conjunction with antioxidants such as ascorbic and erythorbic acids, to inhibit colour and flavour deterioration caused by metal-catalysed enzymatic oxidation. Recommended usage levels are generally 0.1% to 0.3% with the antioxidant at 100 to 200 ppm.
- d. Inactivate undesirable enzymes: oxidative browning in most fruits and vegetables is catalysed by the naturally present polyphenol oxidase. The enzymatic activity is strongly dependent on pH.

Addition of citric acid to reduce pH below 3 will result in inactivation of this enzyme and prevention of browning reactions.

### **The use of fruit juices in confectionery products**

During the last decade, the concept of fruit juices has gained immensely on consumer popularity. The majority of new non-alcoholic and alcoholic fruit drink products were a combination of syrups, fruit juices and flavours. The confectionery industry followed suit and new products incorporated fruit juices as part of their confectionery formulations and processes. Fruit juice concentrates of high solids are often used instead of normal or single-fold juices. Juice concentrates are made of pure fruit juices. The process starts with pressing fruits and obtaining pure fruit juice; this is stabilised by heat treatment which inactivates enzymes and micro-organisms. The next processing step is concentration under vacuum up to 40-65° Brix or 4-7 fold. The concentrates are then blended for standardisation and stored. These fruit juice concentrates are often further stabilised by the addition of sodium benzoate and potassium sorbate and are usually stored away from light and are refrigerated or frozen. Depectinised fruit juices are also used to prevent foaming in confectionery processes and are essential for use in clear beverage products. Fruit juice concentrates which are depectinised, and have added preservatives are called stabilised, clarified, fruit juice concentrates. Fruit juices are used in confectionery products in conjunction with natural and artificial flavours which provides intense flavour impact and are cost-effective for a confectionery product. The traditional concern in using fruit juice concentrates in confectionery applications has been the effect of the natural acids on the finished product, particularly the formation of invert sugar during processing. This is a logical concern since concentrates contain differing amounts and types of acids. For example: apple, cherry, strawberry and other berries contain primarily malic acid. Grapes mainly contain tartaric acid. Cranberry is high in quinic acid. Citrus fruits and pineapple contain differing amounts of citric acid. The concentrates, when used, are normally buffered to a pH of 5-7 with sodium hydroxide.

In formulating products with fruit juice concentrates, the solids of the concentrate are considered as mostly reducing sugars and a reduction in corn syrup is made to compensate for equivalent amount of reducing sugar being added in the concentrate. The exact replacement can be determined by measuring the D.E. of the concentrate to be added. In formulations when small amounts of concentrate are used (less than 1%), no adjustment is made since the reducing sugar contribution of the concentrate is not significant. Fruit juice concentrates can also be used to provide a source of natural

colour, in particular red colour. Grape, raspberry, cherry, strawberry and cranberry concentrates in small amounts are very effective in colouring cream centres. The inclusion of fruit juices in confectionery products is now left up to the imagination of the manufacturer. These products must, of course, hold up to the standards of flavour integrity, and product excellence, during the shelf-life of these products.

( <http://www.fao.org/docrep/V5030e/V5030E0p.htm>)

**Underutilized fruit processing enterprises in the state:**

1. Identify the market and promote new brands for underutilized fruit products.
2. Take advantage of brand consciousness and diversify the product palette.
3. Develop and maintain strong relationships within the market chain.
4. Improving labour efficiency and use quality packaging materials.

**III. CONCLUSION**

In Sri Lanka potential for cultivating fruits for the domestic and export markets is high. Despite there being a demand for Sri Lankan fruits in abroad, the country faces a serious problem in finding exportable quality fruits in sufficient quantities. The most of fruits in Sri Lanka still remain as underutilized stage and growing in unexploited areas without proper marketing strategies. Developing the market potential for underutilized fruits depend on better marketing and reliable supply of the end product. All kind of fruits rich in nutrients, vitamins and energy they are highly using in ayurvedic and traditional medicine to treat various diseases. Research and scientific investigation needed to explore those properties.

**Table 1. District wise extent under cultivation (ha) – Fruit. (Source: Department of Census and Statistics, Sri Lanka)**

	Oranges	Limes	Mangos	Plantain	Papaw	Pineapple	Passion Fruit
National Total	5,149	9,898	25,747	47,682	6,276	4,962	434
Kurunegala	435	920	4,620	8,362	429	1,636	51
Monaragala	599	2,378	1,843	4,927	318	248	36
Anuradhapura	561	1,017	1,748	2,388	513	6	
Badulla	489	618	832	1,947	283	122	16
Ratnapura	239	725	1,214	5,705	328	93	84
Kanay	241	206	1,862	3,074	427	31	34
Nuwara Eliya	192	167	556	1,179	124	9	7
Gampaha	88	157	1,835	2,586	525	1,780	31
Hambantota	190	515	1,255	2,041	496	76	9
Puttalam	504	414	972	1,678	348	229	14
Ampara	384	1,095	873	1,272	229	180	7
Matale	290	308	1,043	1,721	228	19	11
Kegalle	72	112	923	2,710	197	105	16
Galle	112	207	853	1,469	412	84	29
Polonnaruwa	295	362	858	992	219		
Matara	77	136	1,384	1,453	244	107	5
Kaluthara	54	149	928	1,343	349	152	81
Jaffna	38	85	465	565	46		
Mahaweli. 'H' Area	62	74	180	672	265		
Batticaloa	63	47	500	460	60		
Colombo	15	37	361	481	130	83	2
Trincomalee	85	73	428	246	38		
Vavuniya	34	48	69	185	17		
Mannar	8	14	44	68	18	1	2
Kilinochchi	4	6	46	146	17		
Mullativu	19	29	56	12	14	1	

**Table 2. Major processed products which can be prepared from fruits (DHEERAJ SINGH *et al.*, 2008).**

Processed Product	Fruits
Jam	Jamun, Karonda, Aonla, Mulberry, Soursop, Tamarind, Wood apple
Jelly	Tamarind, Jamun, Karonda, Tamarind
Preserved	Ber, Aonla, Ker, Sangri, Karonda, Bael, Karonda, Soursop
Candy	Aonla, Karonda, Tamarind
Glazed Fruits	Tamarind, Annanas, Aonla
Confectionary	Amra, Aonla, Tamarind
Juice/Syrup/ Squash	Beverage/ Aonla, Ber, Bael, Jamun, Karonda, Phalsa, Mulberry, Pomegranate, Soursop, Wood apple, Tamarind
Wine	Mahua, Jujube, Ber, Indian fig, Karonda
Chutney	Karonda, Wood apple, Aonla
Sauce	Karonda, Tamarind, Wood apple, Pomegranate
Pickle	Jujube, Tamarind, Ker, Lasora, Gonda
Dehydration	Aonla, Karonda, Ker, Bael, Ber, Custard apple
Frozen Puree	Bael, Karonda, Ker, Phalsa Tamarind, Custard apple
Canning	Ber, Aonla, jamun, Ker

#### REFERENCES

- [1] Agent (1994). A survey of the market for fruits and vegetables in the hotel and restaurant industry, Agent's business production, processing and marketing information centre, Issue No 19, Colombo, 25pp
- [2] ChamathkaJayawardena(2013).The Cancer fighting fruit. Ceylontoday.
- [3] DHEERAJ SINGH\*, LOBSANG WANGSHU†, PRAHALA V.C.(2008). PROCESSING AND MARKETING FEASIBILITY OF [1] UNDERUTILIZED FRUIT SPECIES OF RAJASTHAN. Contributed Paper presented at IAMO Forum
- [4] Sector brief Fruits and vegetables (2011). Compiled by the Ceylon Chamber of commerce.
- [5] Subasinghe S (2014). Cultivation of medicinal fruits, trees. Daily News
- [6] Williams J T; Haq N. (2002). Global research on underutilized crops - an assessment of current activities and proposals for enhanced cooperation. Southampton, UK: International Centre for Underutilised Crops. ISBN 92-9043-545-3. Retrieved 21 August 2013.

#### AUTHORS

**First Author** – Author name, qualifications, associated institute (if any) and email address.

**Second Author** – Author name, qualifications, associated institute (if any) and email address.

**Third Author** – Author name, qualifications, associated institute (if any) and email address.

**Correspondence Author** – Author name, email address, alternate email address (if any), contact number.









Fig 1. Pictures of some selected neglected and underutilized fruits in Sri Lanka.

1. Delum – *Punica granatum*, 2. Rambutan - *Nephelium lappaceum*, 3. Rose apple/ Jambu – *Syzygium samangense*, 4.Lovi – *Flacourtial inermis*, 5.Waraka - *Artocarpus heterophyllus*, 6.Himbatu - .....7.Lavalu – *pouteria campechiana*, 8.Star fruit - *Averrhoa carambola*, 9.Kirala – *Snaeratia alba*,10. Guava – *Pisidium guajava*, 11. Mora -*Euphoria longan*,12. Lemon – *Citrus limon*, 13.Ugurassa – *Flacourtia indica*, 14.Tamarind – *Tamarindus indica*, 15. Mandosteen – *Garcinia mangosteen*, 16.Masan - *Ziziphus mauritiana var. mauritiana*, 17.Durian - *Durio zibethinus*, 18.Wali anodaha – *Annona spp.*, 19.Katu anodha –*Annona muricata*,20. Goraka – *Garcenia zeylanica*, 21. Pomelo – *Citrus maxima*,22. Nas narang – *Citrus reticulate*, 23.Lime – *Citrus aurantifolia*, 24.Veralu – *Elaeocarpus serratus*, 25.Nelli – *Embelica officinalis*, 26.Namnan – *Cynometra cauliflora*, 27. Cashew nut – *Anacardium occidentale*, 28.Sapathilla/Fuzzy fruit - *Actinidia deliciosa*, 29.Passion fruit – *Passiflora edulis*, 30.Gaduguda – *Baccauria metieyana*,31.Dhan – *Syzygium cumini*,32.Velvet Tmarind – *Dialium indicum*, 33.Woodapple – *Ferronia limonia*,34.Beli – *Aegle marmelos*, 35.Naran – *Cirtus madurensis*, 36.Avocado – *Persea Americana*, 37.Water melon – *Citrullus lanatus*, 38.Bilin – *Averrhoa bilimbi*, 39.Kon- *Schleichera oleosa*, 40.Plau - *Manilkara hexandra*, 41.Weera - *Drypetes sepiaria*

# Central Pontinemyelinolysis: Report of a Rare Case with a Good Outcome.

Dr. D. Sridhar<sup>\*</sup>, Dr. G. Balaraju<sup>\*\*</sup>, Dr. R. Siddeswari<sup>\*\*\*</sup>, Dr. B. Sudarsi<sup>\*\*\*\*</sup>

<sup>\*</sup> M.D., Asst Prof. of Medicine, Osmania General Hospital, Hyderabad, Telangana State, India.

<sup>\*\*</sup> M.D., Assoc. Prof. of Medicine, Osmania General Hospital, Hyderabad, Telangana State, India.

<sup>\*\*\*</sup> M.D., Prof. of Medicine, Osmania General Hospital, Hyderabad, Telangana State, India.

<sup>\*\*\*\*</sup> M.D., Asst Prof. of Medicine ; Osmania General Hospital, Hyderabad, Telangana State, India.

**Abstract-** Central pontinemyelinolysis is a noninflammatory demyelinating disorder characterized by the loss of myelin in the center of the basis pontis usually seen in those with chronic alcoholism and in malnourished persons and by rapid correction of chronic hyponatremia. The clinical features vary depending on the extent of involvement. Demyelination can occur outside the pons as well and diagnosis can be challenging if both pontine and extrapontine areas are involved. We herein report a case of myelinolysis involving pons.

**Index Terms-** Central pontinemyelinolysis (CPM), Extrapontinemyelinolysis (EPM), Osmotic demyelination syndrome(ODS).

## I. INTRODUCTION

Central pontinemyelinolysis (CPM) was described by Adams and colleagues in 1959 as a disease affecting alcoholics and the malnourished<sup>1</sup>. [http://jnnp.bmj.com/content/75/suppl\\_3/ii22.full.html](http://jnnp.bmj.com/content/75/suppl_3/ii22.full.html) - ref-1 The concept was extended from 1962 with the recognition that lesions can occur outside the pons, so-called extrapontinemyelinolysis (EPM). In 1976 a link between these disorders and the rapid correction of sodium in hyponatraemic patients was suggested, and by 1982 substantially established<sup>2</sup>.

The precise incidence of CPM is not known, but the ability to diagnose it during life has been helped by modern neuroimaging, particularly with an MRI of the brainstem. Clinical manifestations of CPM include truncal and gait ataxia, pseudobulbar syndrome, and bilateral upgoing plantar responses. There is no proven effective therapy for CPM<sup>3,4</sup>.

In the past, the prognosis of CPM was thought to be poor with a mortality rate of over 50%. With greater general awareness of the disorder and a better ability to diagnose it, the prognosis is improving. In some instances, complete recovery of CPM has been reported.<sup>4</sup>

We report an unusual case of CPM affecting the brain in a man with chronic alcohol as known risk factor to develop this condition with normal serum sodium.

## II. CASE REPORT

A 40 yr old male, K/C/O Pulmonary Koch's since 2 months(on ATT) presented with Slurring of speech since 1 week, Choking on attempting to swallow liquids since 1 week

,Weakness of both upper limbs and lower limbs that gradually progressed over 4days.H/o weakness of limbs started as difficulty in mixing his food,buttoning/unbuttoning his shirt & slippage of slippers with his knowledge;Later there was difficulty in combing his hair & stand and inability to get up from sitting/squatting position.There was difficulty in lifting his head/sitting from lying position without support. No H/o hoarseness of voice .No H/o S/o sensory involvement.No H/o S/o bowel & bladder involvement.No H/o S/o cerebellar symptoms.No history of similar complaints in the past.Past H/o fever & productive cough since 2 months; for which he was started on Cat I ATT.No past H/o HTN,DM.No H/o any other drug intake or previous hospitalization.Family history – Not significant.

**PERSONAL HISTORY.**-Chronic alcoholic-Consumed approx. 180 ml of whisky per day for the last 15 years.Non-smoker on examination patient was conscious & coherent thin built, moderately nourished(BMI-20) No pallor / icterus / cyanosis / clubbing, Nokoilonychia / lymphadenopathy / edema. No neurocutaneous markers. No peripheral nerve thickening.

**VITAL DATA**Temp.- afebrile Pulse – 82/min;regular;normal volume;all peripheral pulses felt;B.P – 100/70 mmHg in Lt. upper limb in supine position, Respiratory Rate – 20/min CNS examination Skull & Spine – normal, Oriented to time, place, person.

Memory-intact.Speech & Language – Dysarthria present - With abnormal lingual & velars (spastic dysarthria), Naming, comprehension, repetition, reading& writing present.

**CRANIAL NERVES I - XII** – Normal , Jaw jerk brisk, Gag & Palatal reflexes present, Decreased movements of tongue with spasticity; no fasciculations, all are suggestive of pseudobulbar involvement.

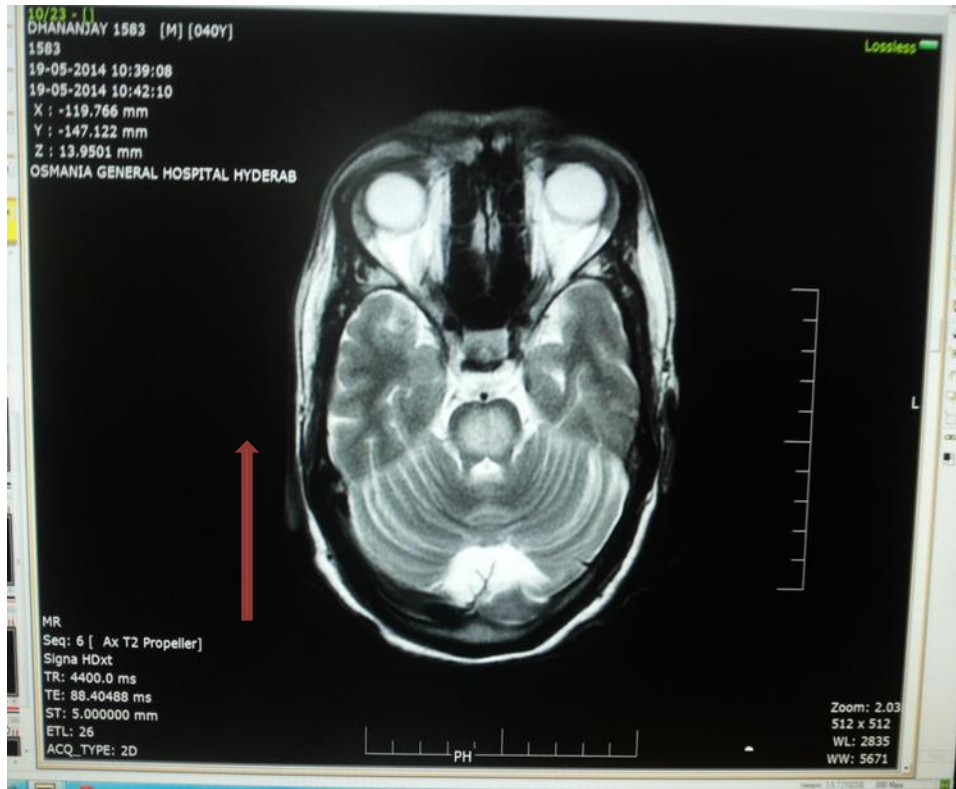
**MOTOR SYSTEM:** Bulk and tone – Normal ,Power – both upper limbs-proximal 4-/5distal – 3/5 hand grip - 50%(right);40%(left) both lower limbs – proximal-3/5distal-2/5 neck – 3/5 trunk <60%.**REFLEXES** :Superficial: Corneal & Conjunctival – Present, Abdominals and Cremasteric – Absent, Plantars – B/L Babinski's sign +Ve .All DTR – Biceps ++ ,Triceps ++, Supinator +, Knee ++ , Ankle +,Coordination & Gait- could not be tested.Sensory system – Normal.Cerebellar system – NormalAutonomic System – Normal.No meningeal signs.Other systems are normal.

On investigation CBP ESR,CUE,LFT, RBS, Blood urea, Sr. Creatinine, Lipid profile are normal, Sr. Na–137meq/lSr. K– 3.8meq/ lt. HIV/HbsAg – Non reactive, ECG, CXR, USG Abdomen– Normal. CT BRAIN - Ill defined hypodensity noted in central pons.MRI Brain with contrast – Ill defined altered



signal intensity which is hyperintense on T2W1,FLAIR and hypointense on T1W1 and restricted on DW1 seen in pons sparing the periphery S/o CENTRAL PONTINE MYELINOLYSIS .The patient was given CAT I ATT

,supportive treatment along with Inj.Multivitamin.Advised CAT I ATT for 6 months and multivitamin tablets at discharge along with physiotherapy & speech therapy. On follow up-Patient improved after 4weeks and became normal after 12 weeks.



### III. DISCUSSION

Demyelinating disease of the brain has 3 subtypes

CPM - lesion is confined to pons. Extra Pontine Myelinolysis - lesions confined to the basal ganglia, cerebrum and cerebellum. ODS - CPM and EPM lesions are both present.

Central Pontine Myelinolysis(CPM) and Osmotic Demyelinating Syndromes(ODS) are rare medical

conditions. Exact incidence – unknown; derived primarily from autopsy series.

It is seen in all age groups affecting both males and females equally<sup>1</sup>.

In 1976 Tomlinson and colleagues suggested that the rapid correction of serum sodium in hyponatremic patients was the causative factor<sup>8</sup>. Since then several cases of CPM with normonatremia particularly in alcoholics have been reported. CPM has been traditionally associated with rapid correction of hyponatremia although this is not the cause in all cases.

Chronic Alcoholism, Chronic malnutrition, Chronic debilitating conditions, Liver transplantation, Burns, AIDS, Hyperemesis gravidarum, CRF on dialysis, Cancer are risk factors<sup>3,4</sup>.

The predilection of the myelinolysis to pons is thought to be the result of the grid arrangement of the oligodendrocytes in the base of the pons which limits their mechanical flexibility and therefore their capacity to swell. During hyponatremia these cells can only adapt by losing more ions instead of swelling making them prone to damage when sodium is replaced<sup>5,6</sup>. Proximity to the extensively vascularized grey matter makes the pons particularly susceptible to damage caused by vasogenic edema and myelinotoxic substances from the vessels<sup>1</sup>.

Microscopically - Destruction of myelinated sheaths with relative sparing of axons & neurons in pontine nuclei in contrast to pontine infarct and No inflammation in contrast to Multiple sclerosis noted<sup>7,8,9</sup>.

Clinical features are highly variable

Typically a rapidly evolving paraparesis or quadriparesis and pseudobulbar symptoms such as dysarthria and dysphagia (most consistent), exaggerated jaw jerk and spastic tongue<sup>9</sup>. Horizontal gaze paralysis, Vertical ophthalmoparesis - demyelination extending through the mid brain. If the lesion extends into the tegmentum of the pons, pupillary and oculomotor abnormalities may occur. Ataxia, movement disorders or behavioral symptoms, Locked in syndrome may be seen. Coma or delirium occur if lesions in the pontine tegmentum and thalamus<sup>5,6</sup>.

EPM - Postural limb tremors, myoclonic jerks, parkinsonian picture, catatonia, dystonia, or pyramidal dysfunction. These may resolve completely or partially over months or they can become permanent.

Diagnosis of CPM is based on clinical suspicion and is confirmed by MRI (positive 1-2 weeks post-onset of symptoms). Hypointense lesions on T1 weighted images, Hyperintense single central symmetric midline pons lesions on T2 with sparing of ventrolateral pons. Sparing of the ventrolateral pons, tegmentum, and corticospinal tracts results in the characteristic “trident-shaped” or “bat-winged” appearance<sup>5,6</sup>. The lesions are non-contrast enhancing.

Recognising the patient at risk and preventing rapid correction of hyponatremia especially chronic severe hyponatremia. The rate of increase of serum sodium be no more than 1-2 mEq/L/hr during the first few hours and no more than 12 mEq/L during the first 24 hours<sup>1</sup>.

The following treatment modalities have been reported:

Thyrotropin releasing hormone, Methylprednisolone, Plasmapheresis, Immunoglobulins<sup>6,7,8</sup>. The exact mechanism of action of TRH, corticosteroids and plasmapheresis is unknown.

A conservative approach with treatment of the precipitating or underlying conditions and appropriate supportive care should be given.

Most of the patients survive and of the survivors, approximately 1/3rd recover; 1/3rd are disabled but are able to live independently; 1/3rd are severely disabled<sup>4,5</sup>. Permanent disabilities range from minor tremors and ataxia to signs of severe brain damage, such as spastic quadriparesis and locked-in syndrome.

In summary, CPM or EPM are devastating and often preventable conditions, with considerable morbidity and/or mortality. Prevention is certainly the key, as current treatment only rarely leads to full recovery. Although imaging advances and a broader neuropathological understanding have improved diagnosis in the last few decades, CPM remains a condition for neuropsychiatrists to be aware of, particularly in view of the multiple neuropsychiatric medication classes in use and the psychiatric illnesses.

The patient in this case was a chronic alcoholic with no electrolyte abnormalities and improved totally with symptomatic treatment.

#### REFERENCES

- [1] Adams RD, Victor M, Mancall EL: Central pontine myelinolysis: a hitherto-undescribed disease occurring in alcoholic and malnourished patients. *American Medical Association Arch Neurol Psychiatry* 1959; 81:154-172 [CrossRef] [Medline]
- [2] Kiley MA, King M, Burns RJ. Central pontine myelinolysis. *J Clin Neurosci*. 1999;6:155-157
- [3] Harrison's text book of Medicine 18th edition
- [4] Kleinschmidt-DeMasters BK, Rojiani AM, Filley CM: Central and extrapontine myelinolysis: then and now. *J Neuropathol Exp Neurol* 2006; 65:1-11 [CrossRef] [Medline]
- [5] Adams R: Living legends: central pontine myelinolysis. *Adv Clin Neurosci Rehabil* 2006; 6:22-22
- [6] R. J. Martin, “Central pontine and extrapontine myelinolysis: the osmotic demyelination syndromes,” *Journal of Neurology, Neurosurgery, and Psychiatry*, vol. 75, supplement 3, pp. iii22-iii28, 2004
- [7] Ayus JC, Achinger SG, Arief A: Brain cell volume regulation in hyponatremia: role of sex, age, vasopressin, and hypoxia. *Am J Physiol Renal Physiol* 2008; 295:F619-F624 [CrossRef] [Medline]
- [8] D. G. Wright, R. Laureno, and M. Victor, “Pontine and extrapontine myelinolysis,” *Brain*, vol. 102, no. 2, pp. 361-385, 1979. View at Scopus.
- [9] P. J. Martin, C. A. Young; Case Report Central pontine myelinolysis: clinical and MRI correlates; *Postgrad Med J* 1995;71:837-430-432 doi:10.1136/pgmj.71.837.430

#### AUTHORS

**First Author** – Dr. D. Sridhar, M.D., Asst Prof. of Medicine, Osmania General Hospital, Hyderabad, Telangana State, India.

**Second Author** – Dr. G. Balaraju, M.D., Assoc. Prof. of Medicine, Osmania General Hospital, Hyderabad, Telangana State, India.

**Third Author** – Dr. R. Siddeswari, M.D., Prof. of Medicine, Osmania General Hospital, Hyderabad, Telangana State, India.

**Fourth Author** – Dr. B. Sudarsi, M.D., Asst Prof. of Medicine; Osmania General Hospital, Hyderabad, Telangana State, India.



# Utilization of Maternal Health Care Services in a Rural Community of Eastern Nepal

Dr Sanjay Kumar\*, Prof K. C. Premarajan\*\*, Prof S. Nagesh\*\*\*, Prof Nilamber Jha\*\*\*\*

\* Additional Professor, Indira Gandhi Institute of Medical Sciences, Patna, India

\*\* Professor, JIPMER, Pondicherry, India

\*\*\* Professor, Lady Harding Medical College, New Delhi, India

\*\*\*\* Professor, B.P.Koirala Institute of Medical Sciences, Dharan Nepal

**Abstract-** Maternal health care services is one of the prime field for any government to improve if proper utilization of the services availed by the community. A semi structured questionnaire was used to collect information among women in reproductive age group. A total of 224 mothers responded to the questionnaire. More than half were in the age group of 18-25 years. Around two third of the mothers got TT vaccine and delivered at home as well. Sterile bled was used to cut umbilical cord in majority of cases. A number of deliveries are being conducted by untrained personnel and relatives at the cost of maternal health in many developing countries. Trained manpower facilities require improving maternal health and reducing maternal death.

**Index Terms-** maternal health, health care services, utilization.

## I. INTRODUCTION

Maternal health is important not only for mother herself but for their new born and children also. More than half a million maternal deaths occur annually worldwide. Developing countries contribute more than 98% of all these maternal deaths<sup>1</sup>. There is gross difference in maternal mortality among developed and developing countries. Maternal mortality rate (MMR) is only 9/100,000 live birth in UK as compared to 515/100,000 live births in Nepal<sup>2</sup>. Maternal health care services are one of the prime fields for making good maternal health and reduce maternal deaths. Utilization of these services depends on many factors such as income, need for ANC, and absence of complication during pregnancy.

Antenatal care (ANC) is potentially one of the most effective health intervention for reducing maternal mortality and morbidity. All women have a right to a delivery by a trained attendant. However this is true for both homes as well as for hospital delivery. In Nepal only 13% deliveries are conducted by trained personnel. Many more deliveries are conducted by family members and not even trained personnel<sup>2</sup>.

Appropriate maternal health care significantly affects the outcome of pregnancy. Many complications occur due to delay in seeking care by pregnant mothers. It is necessary to utilize the available health care for reducing mortality and morbidity. This study was aimed to know the utilization of maternal health care services during antenatal, delivery and post natal period and factors affecting them.

## II. MATERIAL AND METHODS

Nepal is a low income country in South East Asia. More than 80 % population lives in rural areas. Each district in Nepal is divided into VDCs (Village developments committees) and later usually in 9 (1-9) wards. There are sub health posts catering to the community at VDC level. Medical officers are posted at PHCs (Primary Health Centre) and rest lower level health facility is run by other health personnel. ANC services are available from Sub Health Post to all higher facility. There are many female community health volunteer (FCHV) in each ward to guide and help properly for all health problems.

Study was conducted in one of the VDC of eastern Nepal. All women of child bearing age group (15-49) who delivered in last six months were included in the study. Women not present at more than two visits, not willing to participate, not living permanently and who had come to visit their relatives were excluded. Women who had abortion, still birth or neonatal death were also excluded. Women not living permanently but spent antenatal, natal and post natal period of their last confinement in the study area were included in the study subjects.

A semi structured questionnaire was used to collect information. The questionnaire included variables regarding ante natal, natal, and post natal care during the last pregnancy and socio-demographic profile.

## III. RESULTS

A total of 224 mothers responded to the questionnaire. More than half of them belonged to 21-25 years followed by 22% in 15-20 years, 20% in 25-29 years and 7% in more than 30 years age group. 83% women were illiterate and only a few (10.8%) were working women. It was observed that more than half women conceived first time in their twenties.

One fifth (20.5%) of women did not visit any health facility for antenatal care (Sub-health post/ health post/ district hospital/ tertiary care hospital/ private clinics). More than two third went for ANC voluntarily and few due to parents' compulsion (7%) or for TT supplementation (7%). One third mothers visited for 1-2 times and another third for 3-4 times. Among the women (n=46) who did not visit health facility, 43% were not knowing about ANC and 39% explained that they did not have any complication to go for ANC. Two third respondents took iron tablets and 1/4<sup>th</sup> folic acid. We could also find that almost one fifth (18%)

restricted certain foods due to the belief that they may affect health of the mother or the baby.

Three fourth mothers got TT and almost the same percentage (73.2%) delivered their baby at home. Only 1/4<sup>th</sup> delivery was attended by doctors or other health aid. We could find that 88% used sterile bled for cutting umbilical cord and 40% applied red solution (medication) on stump after cutting the cord.

Colostrum was not given to 25% of babies and instead was given prelacteal feeds such as cow's milk (59%) or other milk.

**Table 1: Care received by the subjects in last Pregnancy and Delivery**

Characteristic	Number (%)
<b>Supplementation during Pregnancy</b>	132 (58.9)
Iron	62 (27.0)
Folic acid	22 (9.8)
Calcium	
<b>TT Taken</b>	
Yes	174 (77.6)
No	50(22.4)
<b>Place of delivery</b>	
Home	164 (73. )
Hospital	60 (26.8)
<b>Delivery conducted by</b>	
Trained TBA	22 (9.8 )
Untrained TBA ( Dai)	76 (33.9 )
Family member	72 (32.1 )
Doctor	54 (24.1 )
<b>Type of delivery</b>	
Normal	214 (95.5 )
Instrumental	6 (2.6 )
Operated	4 (1.7 )
<b>Material used for cutting the cord</b>	
Sterile bled	198 (88.3 )
Scissors	24 (10.7 )
Grass cutter	2 (0.8 )
<b>Material applied on stump</b>	
Ash	36 (16.0 )
Red solution	90 (4.1 )
Mustard oil	12 (5.3 )
Do not know	4 (1.7 )
Nothing	82 (36.6 )
<b>Went for health check up after delivery</b>	
Yes	168 (75 )
No	56 (25 )

Table 2: Factors affecting utilization of obstetric care

Factors	Care and Utilization	
	Yes (No)	No (No)
	<b>Seeking ANC care</b>	

<b>Age in Years</b>		
<25	96	66
>25	54	08
<b>Education</b>		
Illiterate	146	40
Literate	32	06
<b>Delivery</b>		
Home	122	42
Hospital	56	04
<b>Material used for cutting cord</b>		
Sterile bled	160	38
Others	18	08
<b>Material applied on stump</b>		
Red solution	60	30
Nothing	70	12
Others	48	04
	<b>Place of Delivery</b>	
<b>Age in Years</b>		
<25	112	50
>25	52	10

#### IV. DISCUSSION

We have documented utilization of maternal care services in a rural community of eastern Nepal in a cross sectional study. According to Nepal Family Health Survey the average age of marriage is 16.4 years<sup>3</sup>. So the expected number of teenage pregnancy is also high. We observed that more than half of women were pregnant first time in their twenties. A high proportion of women had less than even three visits to the health facilities during their last pregnancy. The recommended visits for ANC during pregnancy are at least 3 visits. There is a need for improvement in knowledge and awareness regarding the benefits of ANC. There is good awareness and availability regarding tetanus toxoid immunization resulting in 3/4<sup>th</sup> women getting TT vaccines either from health facility or other place. It was observed that many women went to medical shop and received TT even though they did not go for proper ANC check up. It has been found by researcher that many women in developing country still do not go to health facility for ANC check up<sup>4</sup>. There are factors that lead to restriction of ANC visits by the women such as cultural, socioeconomic and others. It is thus important to keep these factors in mind while planning and implementing maternal health care services

In terms of place of delivery in the present study, 73% women delivered at home. This has been supported by the finding from another developing country<sup>5</sup>. Many of these home deliveries were conducted by relatives or untrained attendants at the cost of health and wellbeing of the mother and baby. These practices are prevalent in other country like Bangladesh<sup>5</sup>. (Please mention the name of the country) This study brought out the urgent need to create awareness about the importance of regular antenatal care among rural women of Nepal. Trained manpower and facilities for safe delivery should be made available at health post or sub health post or at PHC to reduce the High Maternal Mortality.

#### REFERENCES

- [1] WHO. Safe Motherhood. Geneva, WHO, 1995.
- [2] Ministry of Health. Annual report of the department of health services. 1994-95. HMG Nepal 1995.
- [3] Nepal family health survey. Family health division, Ministry of Health , Nepal, 1996.
- [4] Hassan IJ, Nesar N. Women's perception regarding obstetric complication and care in a poor fishing community in Karachi. J of Pak med Assoc. 2002; 52(4): 148-52.
- [5] Haque A, Salwyn BJ. Birth practice pattern in urban slums of Dhaka, Bangladesh. Women Health 1996; 24(1): 41-58.

#### AUTHORS

**First Author** - Dr Sanjay Kumar, Additional Professor, Indira Gandhi Institute of Medical Sciences, Patna, India, Email: [sanjay131@yahoo.com](mailto:sanjay131@yahoo.com)

**Second Author** – Prof. K. C. Premarajan, Professor, JIPMER, Pondicherry, India

**Third Author** – Prof. S. Nagesh, Professor, Lady Harding Medical College, New Delhi, India

**Fourth Author** – Prof. Nilamber Jha, Professor, B.P.Koirala Institute of Medical Sciences, Dharan Nepal

**Correspondence Author** – Dr Sanjay Kumar , Additional Professor, Department of community medicine, Indira Gandhi Institute of Medical Sciences, Patna, India, Email: [sanjay131@yahoo.com](mailto:sanjay131@yahoo.com), Alternate Email: [sanjay131@gmail.com](mailto:sanjay131@gmail.com), Contact no: +91 9473191827

# Effects of Phosphorus and Zinc on the Growth and Yield of Mungbean (BARI mug 6)

M. M. Rahman<sup>1</sup>, M. J. Adan<sup>2</sup>, M. S. N. Chowdhury<sup>3</sup>, M. S. Ali<sup>1</sup> and S. T. Mahabub<sup>4</sup>

<sup>1</sup>Department of Agronomy, Sher-e-Bangla Agricultural University, Dhaka-1207, Bangladesh

<sup>2</sup>Department of Pathology, Sher-e-Bangla Agricultural University, Dhaka-1207, Bangladesh

<sup>3</sup>Department of Agricultural Botany, Sher-e-Bangla Agricultural University, Dhaka-1207, Bangladesh

<sup>4</sup>Institute of Seed Technology, Sher-e-Bangla Agricultural University, Dhaka-1207, Bangladesh.

**Abstract-** A field experiment was conducted at the Sher-e-Bangla Agricultural University Farm, Dhaka 1207, during the kharif season of 2014 to study the effects of Phosphorus and Zinc on the growth and yield of Mungbean (BARI Mug 6). Four levels of phosphorus (P) (0, 15, 20 and 25 kg P ha<sup>-1</sup>) and three levels of zinc (Zn) (0, 1.5 and 3 kg Zn ha<sup>-1</sup>) were used in the study. The results revealed that seed and stover yield of mungbean increased with increasing levels of phosphorus and zinc up to certain level. In case of P the maximum significant seed yield (1.5 t ha<sup>-1</sup>) and stover yield (2.47 t ha<sup>-1</sup>) were obtained with the treatment P<sub>3</sub> (25 kg P ha<sup>-1</sup>) and the minimum significant seed yield (1.11 t ha<sup>-1</sup>) and stover yield (2.06 t ha<sup>-1</sup>) were obtained with the treatment P<sub>0</sub> (0 kg P ha<sup>-1</sup>). In case of Zn the maximum significant seed yield (1.45 t ha<sup>-1</sup>) and stover yield (2.42 t ha<sup>-1</sup>) were obtained with the treatment Zn<sub>2</sub> (3 kg Zn ha<sup>-1</sup>) and the minimum significant seed yield (1.27 t ha<sup>-1</sup>) and stover yield (2.21 t ha<sup>-1</sup>) were obtained with the treatment Zn<sub>0</sub> (0 kg Zn ha<sup>-1</sup>). The maximum significant plant height (52.05 cm), number of branch plant<sup>-1</sup> (2.87), seed yield (1.68 t ha<sup>-1</sup>), yield contributing factors like number of pods plant<sup>-1</sup> (20.86), number of seeds pod<sup>-1</sup> (12.65) and weight of 1000-seeds (45.11 g) were obtained with the treatment combination P<sub>2</sub>Zn<sub>2</sub> (20 kg P ha<sup>-1</sup> + 3 kg Zn ha<sup>-1</sup>).

**Index Terms-** Mungbean, phosphorus, zinc, growth and yield.

## I. INTRODUCTION

Mungbean (*Vigna radiata* L.) is one of the important pulse crops of Bangladesh, as it is an excellent source of easily digestible protein [1]. It belongs to the family Leguminosae. BARI mug 6 is a yield potential, innovated by Bangladesh Agricultural Research Institute (BARI) that fits well in crop rotation between two cereal crops [2]. In Bangladesh, daily consumption of pulses is only 14.30 g capita<sup>-1</sup> day<sup>-1</sup> [3], while World Health Organization (WHO) suggested 45 g capita<sup>-1</sup> day<sup>-1</sup> for a balanced diet. Mungbean is rich source of vegetable protein. It is considered as poor man's meat containing almost triple amount of protein as compared to rice. It contains 1-3% fat, 50.4% carbohydrates, 3.5-4.5% fibers and 4.5-5.5% ash, while calcium and phosphorus are 132 and 367 mg per 100 grams of seed, respectively [4]. Hence, on the nutritional point of view, mungbean is perhaps the best of all other pulses [5]. The excessive uses of N, P, S, K and Zn containing fertilizer decrease nutrient availability as well as yield. So it is essential to recommend the proper combination of nutrients to achieve the

maximum and sustainable yield goal. Phosphorus plays a remarkable role in plant physiological processes. Phosphorus is a key constituent of ATP and it plays a significant role in the energy transformation in plants [6] and also essential for energy storage and release in living cells. The Zn essentially is being employed in functional and structural component of several enzymes, such as carbonic anhydrase, alcohol dehydrase, alkaline phosphatase, phospholipase, carboxypeptidase [7] and RNA polymerase [8]. Further, plants emerging from seeds with lower Zn could be highly sensitive to biotic and abiotic stresses [9]. Zn enriched seeds performs better with respect to seed germination, seedling growth and yield of crops [10]. The farmers of Bangladesh generally grow mungbean with almost no fertilizers. Considering the above facts the present study is aimed at following objectives to determine the effects of phosphorus and Zinc on the growth and yield of mungbean and to study the combine effect of phosphorus and zinc on growth and yield of mungbean.

## II. MATERIALS AND METHODS

The experiment was conducted in the experimental farm of Sher-e-Bangla Agricultural University, Sher-e-Bangla Nagar, Dhaka-1207, Bangladesh during the period from April to July, 2014. The location of the experimental site was at 23.75° N latitude and 90°34' E longitude with an elevation of 8.45 meter from sea level. Soil of the study site was silty clay loam in texture belonging to series. The area represents the Agro-Ecological Zone of Madhupur tract (AEZ-28) with P<sup>H</sup> 5.8-6.5, ECE-25.28 [11]. BARI mug 6, a high yielding variety of mungbean was released by Bangladesh Agricultural Research Institute, Joydebpur, Gazipur in 2003. It is photo insensitive, semi synchronous maturity, short lifespan (60 to 65 days) and bold seeded crop. Its yield potentiality is about 2 t ha<sup>-1</sup>. This variety is resistant to yellow mosaic virus diseases, insects and pest attack. The plot selected for the experiment was opened by power tiller driven rotovator on the 10<sup>th</sup> April 2014, afterwards the land was ploughed and cross-ploughed several times followed by laddering to obtain a good tilth. The experiment consisted of two factors: Factor A: Phosphorus (P), P<sub>0</sub>= No P ha<sup>-1</sup>, P<sub>1</sub>=15 kg P ha<sup>-1</sup>, P<sub>2</sub>= 20 kg P ha<sup>-1</sup> and P<sub>3</sub>= 25 kg P ha<sup>-1</sup>; Factor B: Zinc (Zn), Zn<sub>0</sub>= No Zn ha<sup>-1</sup>, Zn<sub>1</sub>=1.5 kg Zn ha<sup>-1</sup> and Zn<sub>2</sub>=3 kg Zn ha<sup>-1</sup>. Levels of these two nutrient elements made 12 treatment combinations. The experiment was laid out in a Randomized Complete Block Design (RCBD) with three

replications. The total number of plots was 36, each measuring 2.5 m x 2 m. Recommended blanket doses of N, K and Sulphur (20 kg N from urea, 30 kg K from MoP and 15 kg S ha<sup>-1</sup> from Gypsum, respectively) were applied. The whole amounts of MoP, Gypsum and half of total Urea fertilizer were applied as basal dose during final land preparation. The rest of the urea fertilizer was applied after 28 days of seed sowing. The required amounts of P (from TSP) and Zn (from Zinc oxide) were applied at a time as per treatment combination after field layout of the experiment and were mixed properly through hand spading. Mungbean seeds were sown on 18<sup>th</sup> April 2014 in lines following the recommended line to line distance of 30 cm and plant to plant distance of 10 cm. Various intercultural operations such as thinning of plants, weeding and spraying of insecticides were accomplished whenever required to keep the plants healthy and the field weed free. The crop was harvested at maturity on 18<sup>th</sup> June 2014. The harvested crop of each plot was bundled separately. Ten (10) plants from each plot were selected as random and were tagged for the data collection. Data were collected at harvesting stage. The collected data were analyzed with the help of MSTAT-C program and mean values of all the parameters were adjusted by Duncan's Multiple Range Test (DMRT) at 5% level of probability [12].

### III. RESULTS AND DISCUSSION

#### **Effect of phosphorus on growth and yield of Mungbean**

Mungbean plants showed significant variation in respect of plant height, number of branches plant<sup>-1</sup>, number of pods plant<sup>-1</sup>, number of seeds pod<sup>-1</sup>, Pod length, weight of 1000-seeds, seed yield (t ha<sup>-1</sup>) and stover yield (t ha<sup>-1</sup>) when phosphorus in different doses were applied (Table 1).

**Plant height, number of branches plant<sup>-1</sup>, number of pods plant<sup>-1</sup>, number of seeds pod<sup>-1</sup>:** Plant height, number of branches plant<sup>-1</sup>, number of pods plant<sup>-1</sup>, number of seeds pod<sup>-1</sup>,

Pod length and weight of 1000-seeds were increased with P levels from 0-20 kg ha<sup>-1</sup> then declined. The highest plant height (51.09 cm), number of branches plant<sup>-1</sup> (2.62), number of pods plant<sup>-1</sup> (19.36) and number of seeds pod<sup>-1</sup> (11.73) were obtained with 20 kg P ha<sup>-1</sup>. On the other hand, the lowest plant height (42.24 cm), number of branches plant<sup>-1</sup> (1.65), number of pods plant<sup>-1</sup> (14.70) and number of seeds pod<sup>-1</sup> (9.40) were observed in the P<sub>0</sub> treatment where no phosphorus was applied. The result is agreed with the findings of Kumar *et al.* [13].

**Pod length and weight of 1000-seeds:** Pod length and weight of 1000-seeds as affected by different doses of phosphorus showed a statistically significant variation. Among the different doses of P the highest pod length (9.46cm) and weight of 1000-seeds (43.43 g) was observed in P<sub>2</sub> (20 kg P ha<sup>-1</sup>). The lowest pod length (6.79 cm) and weight of 1000-seeds (40.00 g) were recorded in the P<sub>0</sub> treatment where no phosphorus was applied. The result is agreed with the findings of Kumar *et al.* [13] who observed significant increase in pod length, number of grains pod<sup>-1</sup>, weight of 1000-seeds, seed yield, and stover yield of mungbean due to the application of increasing level of P fertilizer.

**Seed yield and stover yield:** Significant variation was observed on the seed yield and stover yield of mungbean when different doses of P were applied (Table 1). The highest seed yield (1.50 t ha<sup>-1</sup>) was recorded in P<sub>2</sub> (20 kg P ha<sup>-1</sup>) but the highest stover yield (2.47 t ha<sup>-1</sup>) was recorded in P<sub>3</sub> (30 kg P ha<sup>-1</sup>) treatment. The lowest seed yield (1.11 t ha<sup>-1</sup>) and stover yield (2.06 t ha<sup>-1</sup>) of mungbean was recorded in the P<sub>0</sub> treatment where no P was applied. There was no significant difference between P<sub>2</sub> and P<sub>3</sub> treatments. The result is agreed with the findings of Oad *et al.* [14] who observed significant increase in grain yield, and straw yield of mungbean due to the application of 100 kg P fertilizer.

**Table. 1 Effect of phosphorus on growth parameters**

Levels of P (kg ha <sup>-1</sup> )	Plant height (cm)	No. of branches plant <sup>-1</sup>	No. of pods plant <sup>-1</sup>	No. of seeds pod <sup>-1</sup>	Pod length (cm)	Weight of 1000-seeds (gm)	Seed yield (t ha <sup>-1</sup> )	Stover yield (t ha <sup>-1</sup> )
P <sub>0</sub>	42.24 d	1.65 d	14.70 c	9.40 c	6.79 d	40.00 c	1.11 c	2.06 c
P <sub>1</sub>	46.50 c	2.21 c	16.90 b	10.48 b	7.59 c	41.89 b	1.29 b	2.23 b
P <sub>2</sub>	51.09 a	2.62 a	19.36 a	11.73 a	9.46 a	43.43 a	1.50 a	2.46 a
P <sub>3</sub>	49.89 b	2.44 b	17.63 b	10.80 b	8.84 b	42.97 ab	1.50 a	2.47 a
LSD <sub>(0.05)</sub>	1.114	0.0927	0.9975	0.696	0.54	1.18	0.075	0.075

In a column figures having similar letter(s) do not differ significantly whereas figures with dissimilar letter(s) differ significantly.

#### **Effect of zinc on growth and yield of Mungbean**

Mungbean plants showed significant variation in respect of plant height, number of branches plant<sup>-1</sup>, number of pods plant<sup>-1</sup>, number of seeds pod<sup>-1</sup>, pod length, weight of 1000-seeds, seed

yield and stover yield when zinc in different doses were applied (Table 2).

**Plant height, number of branches plant<sup>-1</sup>, number of pods plant<sup>-1</sup> and number of seeds pod<sup>-1</sup>:** Among the different fertilizer doses, Zn<sub>2</sub> (3 kg Zn ha<sup>-1</sup>) showed the highest plant height (48.26 cm), number of branches plant<sup>-1</sup> (2.41), number of pods plant<sup>-1</sup> (18.30) and number of seeds pod<sup>-1</sup> (11.1). On the contrary, the lowest plant height (46.56 cm), number of branches plant<sup>-1</sup> (2.04), number of pods plant<sup>-1</sup> (16.12) and number of



seeds pod<sup>-1</sup> (9.94) was observed in the treatment where no sulphur was applied. Islam *et al.* [15] found significant increase in plant height, number of branches plant<sup>-1</sup>, number of pods plant<sup>-1</sup> and number of seeds pod<sup>-1</sup> of mungbean due to the application of 0.1% - 0.2% ZnO solution.

**Pod length and weight of 1000-seeds:** Among the different Zn doses, Zn<sub>2</sub> (3 kg Zn ha<sup>-1</sup>) showed the highest pod length (8.78 cm) and weight of 1000-seeds (43.23 g). On the other hand, the lowest pod length (7.50 cm) and weight of 1000-seeds (40.91 g) was recorded with Zn<sub>0</sub> treatment where no Zn was applied. Islam

*et al.* [15] found significant increase in pod length of mungbean due to the application of 0.1% - 0.2% ZnO solution.

**Seed yield and stover yield:** Among the different doses of Zn fertilizer, Zn<sub>2</sub> (3 kg Zn ha<sup>-1</sup>) produced the highest seed yield (1.451 t ha<sup>-1</sup>) and stover yield (2.423 t ha<sup>-1</sup>) of mungbean. On the contrary, the lowest seed yield (1.27 t ha<sup>-1</sup>) and stover yield (2.218 t ha<sup>-1</sup>) of mungbean were found in Zn<sub>0</sub> where no Zn fertilizer was applied. In case of stover yield Zn<sub>0</sub> and Zn<sub>1</sub> were statistically similar.

**Table 2 Effect of zinc on growth parameters**

Levels of Zn (kg ha <sup>-1</sup> )	Plant height (cm)	No. of branches plant <sup>-1</sup>	No. of pods plant <sup>-1</sup>	No. of seeds pod <sup>-1</sup>	Pod length (cm)	Weight of 1000-seeds (gm)	Seed yield (t ha <sup>-1</sup> )	Stover yield (t ha <sup>-1</sup> )
Zn <sub>0</sub>	46.56 b	2.04 c	16.12 b	9.94 b	7.50 c	40.91 b	1.27 c	2.21 b
Zn <sub>1</sub>	47.46 ab	2.24 b	17.02 b	10.7 a	8.23 b	42.06 ab	1.34 b	2.28 b
Zn <sub>2</sub>	48.26 a	2.41 a	18.30 a	11.1 a	8.78 a	43.23 a	1.45 a	2.42 a
LSD <sub>(0.05)</sub>	1.11	0.09	0.99	0.69	0.54	1.18	0.07	0.07

In a column figures having similar letter(s) do not differ significantly whereas figures with dissimilar letter(s) differ significantly.

**Interaction effects of phosphorus and zinc on growth and yield of Mungbean**

Combined application of different doses of phosphorus and zinc showed significant effect on the plant height, number of branches plant<sup>-1</sup>, number of pods plant<sup>-1</sup>, number of seeds pod<sup>-1</sup>, pod length, weight of 1000-seeds, seed yield and stover yield of mungbean (Table 3).

**Plant height, number of branches plant<sup>-1</sup>, number of pods plant<sup>-1</sup> and number of seeds pod<sup>-1</sup>:** The lowest plant height (41.23 cm), number of branches plant<sup>-1</sup> (1.54), number of pods plant<sup>-1</sup> (14.05) and number of seeds pod<sup>-1</sup> (8.71) were observed in the treatment combination of P<sub>0</sub>Zn<sub>0</sub> (No phosphorus and No zinc). On the other hand the highest plant height (52.05 cm), number of branches plant<sup>-1</sup> (2.87), number of pods plant<sup>-1</sup> (20.86) and number of seeds pod<sup>-1</sup> (12.65) were recorded with P<sub>2</sub>Zn<sub>2</sub> (20 kg P ha<sup>-1</sup> + 3 kg Zn ha<sup>-1</sup>) treatment combination (Table 3). Ahmed *et al.* [16] found significant increase in plant height, number of branches plant<sup>-1</sup>, number of pods plant<sup>-1</sup> and number

of seeds pod<sup>-1</sup> of mungbean due to the application of increasing level of P and Zn.

**Pod length and weight of 1000-seeds:** The highest pod length (10.55 cm) and weight of 1000-seeds (45.11g) were recorded in P<sub>2</sub>Zn<sub>2</sub> (20 kg P ha<sup>-1</sup> + 3 kg Zn ha<sup>-1</sup>) treatment combination. On the other hand, the lowest pod length (6.42 cm) and weight of 1000-seeds (38.96g) were found in P<sub>0</sub>Zn<sub>0</sub> (Table 3). Singh *et al.* [17] found significant increase in pod length and weight of 1000-seeds of mungbean due to the application of increasing level of P fertilizer.

**Seed yield and stover yield:** The highest seed yield (1.683 t ha<sup>-1</sup>) and stover yield (2.657 t ha<sup>-1</sup>) of mungbean were recorded with the treatment combination of P<sub>2</sub>Zn<sub>2</sub> (20 kg P ha<sup>-1</sup> + 3 kg Zn ha<sup>-1</sup>). On the other hand the lowest seed yield (1.08 t ha<sup>-1</sup>) and stover yield (2.003 t ha<sup>-1</sup>) of mungbean were found in P<sub>0</sub>Zn<sub>0</sub> (No P and No Zn) and P<sub>0</sub>Zn<sub>1</sub> (No P and 1.5 kg Zn) treatment combinations, respectively (Table 3). Singh and Bajpai [18] found that P and Zn significantly improved the grain as well as stover yields of chickpea.

**Table 3. Interaction effect of phosphorus and zinc on growth parameters**

Interaction of P and Zn	Plant height (cm)	No. of branches plant <sup>-1</sup>	No. of pods plant <sup>-1</sup>	No. of seeds pod <sup>-1</sup>	Pod length (cm)	Weight of 1000-seed (gm)	Seed yield (t ha <sup>-1</sup> )	Stover yield (t ha <sup>-1</sup> )
P <sub>0</sub> Zn <sub>0</sub>	41.23 h	1.54 i	14.05 g	8.71 f	6.42 g	38.96 g	1.08 g	2.07 gh
P <sub>0</sub> Zn <sub>1</sub>	42.14 h	1.59 i	14.64 fg	9.29 ef	6.86 fg	39.52 fg	1.12 g	2.00 h
P <sub>0</sub> Zn <sub>2</sub>	43.34 g	1.83 h	15.41 f	10.19 cd	7.11 f	41.51 de	1.15 fg	2.13 fg
P <sub>1</sub> Zn <sub>0</sub>	45.13 f	2.04 g	15.57 f	9.94 de	7.26 f	40.67 ef	1.20 f	2.14 fg
P <sub>1</sub> Zn <sub>1</sub>	46.26 e	2.24 f	16.62 e	10.66 b-d	7.27 f	41.88 c-e	1.29 e	2.17 f
P <sub>1</sub> Zn <sub>2</sub>	48.13 d	2.36 de	18.51 bc	10.82 bc	8.26 e	43.12 bc	1.39 d	2.37 de
P <sub>2</sub> Zn <sub>0</sub>	49.95 c	2.30 ef	17.84 cd	10.56 b-d	7.92 e	42.00 cd	1.38 d	2.30 e

P <sub>2</sub> Zn <sub>1</sub>	51.27 ab	2.68 b	19.36 b	11.99 a	9.91 b	43.16 bc	1.46 cd	2.42 cd
P <sub>2</sub> Zn <sub>2</sub>	52.05 a	2.87 a	20.86 a	12.65 a	10.55 a	45.11 a	1.68 a	2.65 a
P <sub>3</sub> Zn <sub>0</sub>	49.94 c	2.29 ef	17.01 de	10.57 b-d	8.41 de	42.01 cd	1.41 d	2.42 cd
P <sub>3</sub> Zn <sub>1</sub>	50.19 bc	2.44 d	17.46 c-e	11.00 b	8.89 cd	43.69 b	1.52 bc	2.46 bc
P <sub>3</sub> Zn <sub>2</sub>	49.53 c	2.59 c	18.42 bc	10.84 bc	9.24 c	43.20 bc	1.57 b	2.53 b
LSD <sub>(0.05)</sub>	1.11	0.09	0.99	0.69	0.543	1.180	0.075	0.075

In a column figures having similar letter(s) do not differ significantly whereas figures with dissimilar letter(s) differ significantly

#### IV. CONCLUSION

Based on the results of the present study, the following recommendation may be drawn - Application of Phosphorus and Zinc fertilizers @ 20 kg P ha<sup>-1</sup> and 3 kg Zn ha<sup>-1</sup> may be the best combination for higher yield of mungbean and also to maintain soil fertility and productivity than their individual application in Tejgaon series under AEZ No.28 in Bangladesh. Recommendation may vary from soil to soil.

#### REFERENCES

- [1] Kaul, A. K. (1982). Pulses in Bangladesh. BARC, Farm Gate. Dhaka. p. 27.
- [2] BARI. (1998). Mungbean Cultivation in Bangladesh. A booklet in Bengali. Bangladesh Agril. Res. Ins., Joydebpur, Gazipur.
- [3] BBS. (2010). Statistical Year Book of Bangladesh. Statistics Division, Ministry of Planning, Government of the Peoples Republic of Bangladesh. Dhaka. pp. 64-79.
- [4] Frauque, A., Haraguchi, T., Hirota, O. and Rahman, M. A. (2000). Growth analysis, yield, and canopy structure in maize, mungbean intercropping. Bu. Inst. of Tropical Agric. Kyushu University Fukuoka, Japan, 23: 61-69.
- [5] Khan, M. R. I. (1981). Nutritional quality characters in pulses. In: Proc. MAT. Workshop Pulses. pp. 199-206.
- [6] Sangakara, U. R., Frehner, M. and Nosberger, N. (2001). Influence of soil moisture and potassium fertilizer the vegetative growth of mungbean (*Vigna radiata* L.). J. Agron. Crop Sci. 186(2): 73-81.
- [7] Coleman, J.E. (1991). Zinc proteins: Enzymes, storage proteins, transcription factors and Replication Proteins. Ann. Rev. Biochem. 61: 897-946.
- [8] Romheld, V. and Marschner, H. (1991). Function of micronutrients in plants. Micronutrients in Agriculture, In JJ Mortvedt, FR Cox, LM Shuman, RM Welch, eds, Ed 2. Soil Science Society of America, Madison, WI, pp. 297-328.
- [9] Obata, H., Kawamura, S., Senoo, K. and Tanaka, A. (1999). Changes in the level of protein and activity of Cu/Zn Superoxide dismutase in Zinc deficient rice plants. *Oryza savita* L. Soil Sci. Plant Nutr. 45: 891-896.
- [10] Cakmak, I., Torun, B., Erenoglu, B., Kalayci, M., Yilmaz, A., Ekiz, H., and Brun, H.J. (1996). Zinc deficiency in soils and plants in Turkey and plant mechanism involved in Zinc deficiency, Turk. J Agric. (Special issue), 13-23.
- [11] Haider, H. M., Ahmad, F. and Mushtaq, F. (1991). Role of physio-morphic characters imparting resistance in cotton against some insect pests. Pak. Entomol., 21: 61-66.
- [12] Gomez. K. A. and Gomez, A. A. (1984). Statistical Procedures for Agricultural Research (2nd Edn.). John Willey and Sons, Singapore, pp. 28-92.
- [13] Kumar, R., Singh, Y. V., Singh, S., Latore, A. M., Mishra, P. K. and Supriya. (2012). Effect of phosphorus and sulphur nutrition on yield attributes, yield of mungbean (*Vigna radiata* L. Wilczek). J. Chem. and Pharma. Res. 4(5): 2571-2573.

- [14] Oad, F. C., Shah, A. N., Jamro, G. H. and Ghaloo, S. H. (2003). Phosphorus and potassium requirements of mungbean (*Vigna radiata*). J. Applied Sci. 3(6): 428-431.
- [15] Islam. M. S., Bhuiyan, M. S. U. and Miah, M. G. (1989). Effect of zinc on lentil yield and yield components. Lens-News letter. 16(1): 30-32.
- [16] Ahmed, A. U., Rahman, S., Begum and Islam, N.M.S. (1986). Effect of phosphorus and zinc application on the growth, yield and P, Zn and protein content of mungbean. J. Indian Soc. Soil Sci. 34(2): 305-308.
- [17] Singh, A. P., Chaudhury, R. K., and Sharma, R. P. R. (1993). Effect of inoculation and fertilizer levels on yield, nutrient uptake and economics of summer pulses. J. Potassium Res. 90: 176-178.
- [18] Singh, G. and Bajpai, M. R. (1982). Response of Chickpea to P and foliar application of Zinc and sulphuric acid. Indian. Agric. Sci. 52(12): 835-837.

#### AUTHORS

**First Author and Corresponding Author:** M. M. Rahman, B. Sc. Ag. (hons), Sher-e-Bangla Agricultural University, Dhaka-1207, Bangladesh, E-mail: Kbdpulok@gmail.com  
**Second Author:** M. J. Adan, B. Sc. Ag. (hons), Sher-e-Bangla Agricultural University, Dhaka-1207, Bangladesh,  
**Third Author:** M. S. N. Chowdhury, B. Sc. Ag. (hons), Sher-e-Bangla Agricultural University, Dhaka-1207, Bangladesh,  
**Fourth Author:** M. S. Ali, B. Sc. Ag. (hons), Sher-e-Bangla Agricultural University, Dhaka-1207, Bangladesh,  
**Fifth Author:** T. S. Mahabub, B. Sc. Ag. (hons), Sher-e-Bangla Agricultural University, Dhaka-1207, Bangladesh

# Interaction Effect of Phosphorus and Zinc on the Concentrations of N, P, K, S and Zn in Mungbean Stover and Seed

A. Barman<sup>1</sup>, M. J. Chowdhury<sup>2</sup>, S. T. Mahabub<sup>3</sup>, M. Quamruzzaman<sup>2</sup> and A. Mondul<sup>2</sup>

<sup>1</sup>Scientific Officer, Bangladesh Agriculture Research Institute, Joydepur, Gazipur-1701, Bangladesh

<sup>2</sup>Department of Agronomy, Sher-e-Bangla Agricultural University, Dhaka-1207, Bangladesh

<sup>3</sup>Institute of Seed Technology, Sher-e-Bangla Agricultural University, Dhaka-1207, Bangladesh

**Abstract-** A field experiment was conducted at the Sher-e-Bangla Agricultural University Farm, Dhaka 1207, during the kharif season of 2014 to study the effects of Phosphorus and Zinc on the concentrations of N, P, K, S and Zn in Mungbean stover and seed (BARI mug 6). Four levels of phosphorus (P) (0, 15, 20 and 25 kg P ha<sup>-1</sup>) and three levels of zinc (Zn) (0, 1.5 and 3 kg Zn ha<sup>-1</sup>) were used in the study. The results revealed that The N, P, K and S concentration of mungbean plant increased significantly from control to P<sub>2</sub>Zn<sub>2</sub> (20 kg P ha<sup>-1</sup> + 3 kg Zn ha<sup>-1</sup>) treatment combination and again decreased with increasing phosphorus more than 20 kg P ha<sup>-1</sup>. Application of phosphorus and zinc increase organic carbon, N, P, K and S status of postharvest soil significantly.

**Index Terms-** Mungbean, phosphorus, zinc, concentration of N P K S & Zn, stover and seed.

## I. INTRODUCTION

Mungbean (*Vigna radiata* L.) is one of the important pulse crops of Bangladesh, as it is an excellent source of easily digestible protein [1]. It belongs to the family Leguminosae. BARI mug 6 is a yield potential, innovated by Bangladesh Agricultural Research Institute (BARI) that fits well in crop rotation between two cereal crops [2]. In Bangladesh, daily consumption of pulses is only 14.30 g capita<sup>-1</sup> day<sup>-1</sup> [3], while World Health Organization (WHO) suggested 45g capita<sup>-1</sup> day<sup>-1</sup> for a balanced diet. Mungbean is rich source of vegetable protein. It is considered as poor man's meat containing almost triple amount of protein as compared to rice. It contains 1-3% fat, 50.4% carbohydrates, 3.5-4.5% fibers and 4.5-5.5% ash, while calcium and phosphorus are 132 and 367 mg per 100 grams of seed, respectively [4]. Hence, on the nutritional point of view, mungbean is perhaps the best of all other pulses [5]. Phosphorus is a key constituent of ATP and it plays a significant role in the energy transformation in plants and also essential for energy storage and release in living cells. The Zn essentially is being employed in functional and structural component of several enzymes, such as carbonic anhydrase, alcohol dehydrase, alkaline phosphatase, phospholipase, carboxypeptidase [7] and RNA polymerase [8]. Further, plants emerging from seeds with lower Zn could be highly sensitive to biotic and abiotic stresses [9]. Zn enriched seeds performs better with respect to seed germination, seedling growth and yield of crops [10]. The

farmers of Bangladesh generally grow mungbean with almost no fertilizers. Considering the above facts the present study is aimed at following objectives to study the combine effect of phosphorus and zinc on the concentrations of N, P, K, S and Zn in Mungbean.

## II. MATERIALS AND METHODS

The experiment was conducted in the experimental farm of Sher-e-Bangla Agricultural University, Sher-e-Bangla Nagar, Dhaka-1207, Bangladesh during the period from April to July, 2014. The location of the experimental site was at 23.75° N latitude and 90°34' E longitude with an elevation of 8.45 meter from sea level. Soil of the study site was silty clay loam in texture belonging to series. The area represents the Agro-Ecological Zone of Madhupur tract (AEZ-28) with P<sup>H</sup> 5.8-6.5, ECE-25.28 [11]. BARI mug 6, a high yielding variety of mungbean was released by Bangladesh Agricultural Research Institute, Joydebpur, Gazipur in 2003. It is photo insensitive, semi synchronous maturity, short lifespan (60 to 65 days) and bold seeded crop. Its yield potentiality is about 2 t ha<sup>-1</sup>. This variety is resistant to yellow mosaic virus diseases, insects and pest attack. The plot selected for the experiment was opened by power tiller driven rotovator on the 10<sup>th</sup> April 2014, afterwards the land was ploughed and cross-ploughed several times followed by laddering to obtain a good tilth. The experiment consisted of two factors: Factor A: Phosphorus (P), P<sub>0</sub>= No P ha<sup>-1</sup>, P<sub>1</sub>=15 kg P ha<sup>-1</sup>, P<sub>2</sub>=20 kg P ha<sup>-1</sup> and P<sub>3</sub>=25 kg P ha<sup>-1</sup>; Factor B: Zinc (Zn), <sub>0</sub>Zn= No Zn ha<sup>-1</sup>; <sub>1</sub>Zn =1.5 kg Zn ha<sup>-1</sup> and <sub>2</sub>Zn=3 kg Zn ha<sup>-1</sup>. Levels of these two nutrient elements made 12 treatment combinations. The experiment was laid out in a Randomized Complete Block Design (RCBD), with three replications. The total number of plots was 36, each measuring 2.5 m x 2 m. Recommended blanket doses of N, K and Sulphur (20 kg N from urea, 30 kg K from MoP and 15 kg S ha<sup>-1</sup> from Gypsum, respectively) were applied. The whole amounts of MoP, Gypsum and half of Urea fertilizer were applied as basal dose during final land preparation. Rest of the Urea was applied 28 days after sowing. The required amounts of P (from TSP) and Zn (from Zinc oxide) were applied at a time as per treatment combination after field layout of the experiment and were mixed properly through hand spading. Mungbean seeds were sown on 18<sup>th</sup> April 2014 in lines following the recommended line to line distance of 30 cm and plant to plant distance of 10 cm. Various intercultural

operations such as thinning of plants, weeding and spraying of insecticides were accomplished whenever required to keep the plants healthy and the field weed free. The crop was harvested at maturity on 18<sup>th</sup> June 2014. The harvested crop of each plot was bundled separately. Ten (10) plants from each plot were selected as random and were tagged for the data collection. Data were collected at harvesting stage. The collected data were analyzed with the help of MSTAT-C program and mean values of all the parameters were adjusted by Duncan's Multiple Range Test (DMRT) at 5% level of probability [12].

### III. RESULTS AND DISCUSSION

**Nitrogen and phosphorus concentration in stover:** The highest concentrations of nitrogen (0.82%) at P<sub>1</sub>Zn<sub>2</sub> (15 kg P ha<sup>-1</sup> + 3 kg Zn ha<sup>-1</sup>) (treatment and phosphorus (0.67%) at P<sub>2</sub>Zn<sub>2</sub> (20 kg P ha<sup>-1</sup> + 3 kg Zn ha<sup>-1</sup>) treatment ( were recorded in the stover. On the other hand, the lowest concentrations of nitrogen (0.52%) and phosphorus) 0.35 (% were found at P<sub>0</sub>Zn<sub>0</sub> (No P + No Zn)

treatment in stover (Table 1) .Prasad and Ram [13] found that application of Zn (2.5 and 5.0 μg g<sup>-1</sup>) increased the concentration of phosphorus in mungbean and grain yield.

**Potassium and sulphur concentration in stover:** The highest concentrations of potassium (1.47%) and sulphur (0.162%) were recorded at P<sub>2</sub>Zn<sub>2</sub> (20 kg P ha<sup>-1</sup> + 3 kg Zn ha<sup>-1</sup>) (treatment in the stover. On the other hand, the lowest concentrations of potassium (0.65%) and sulphur) 0.084 (% were found at P<sub>0</sub>Zn<sub>0</sub> (No P + No Zn) treatment in stover (Table 1) .

**Zinc concentration in stover:** Insignificant effect of combined application of different doses of P and Zn on the zinc concentration was observed in stover of mungbean (Table 1). The highest concentration of zinc (0.008 %) in the stover was recorded with the P<sub>3</sub>Zn<sub>1</sub> (25 kg P ha<sup>-1</sup> + 1.5 kg Zn ha<sup>-1</sup>) treatment combination. On the other hand, the lowest zinc concentration (0.004 %) was found in P<sub>0</sub>Zn<sub>0</sub> (No P + No Zn) treatment combination.

**Table 1. Interaction effects of phosphorus and zinc on N P K S and Zn concentrations in mungbean stover**

Interaction of P and Zn	N %	P %	K %	S %	Zn %
P <sub>0</sub> Zn <sub>0</sub>	0.52 f	0.35 f	0.65 j	0.084 c	0.004
P <sub>0</sub> Zn <sub>1</sub>	0.60 e	0.42 e	0.86 i	0.118 a-c	0.006
P <sub>0</sub> Zn <sub>2</sub>	0.75 bc	0.44 de	0.91 i	0.141 a-c	0.006
P <sub>1</sub> Zn <sub>0</sub>	0.64 e	0.47 c-e	1.05 h	0.094 bc	0.006
P <sub>1</sub> Zn <sub>1</sub>	0.76 bc	0.57 b	1.06 gh	0.120 a-c	0.006
P <sub>1</sub> Zn <sub>2</sub>	0.82 a	0.61 b	1.25 d	0.149 ab	0.006
P <sub>2</sub> Zn <sub>0</sub>	0.62 e	0.48 cd	1.34 c	0.095 bc	0.006
P <sub>2</sub> Zn <sub>1</sub>	0.71 cd	0.58 b	1.41 b	0.119 a-c	0.007
P <sub>2</sub> Zn <sub>2</sub>	0.80 ab	0.67 a	1.47 a	0.162 a	0.007
P <sub>3</sub> Zn <sub>0</sub>	0.66 de	0.45 de	1.13 ef	0.104 bc	0.007
P <sub>3</sub> Zn <sub>1</sub>	0.73 c	0.51 c	1.18 e	0.117 a-c	0.008
P <sub>3</sub> Zn <sub>2</sub>	0.64 e	0.42e	1.10 fg	0.137 a-c	0.007
LSD <sub>(0.05)</sub>	NS	0.053	0.053	0.245	NS

In a column figures having similar letter(s) do not differ significantly whereas figures with dissimilar letter(s) differ significantly.

NS : Non significant.

**Nitrogen and phosphorus concentration in seed:** The highest concentration of nitrogen (7.46%) and phosphorus (0.69%) were recorded in the seeds of mungbean at P<sub>2</sub>Zn<sub>2</sub> (20 kg P ha<sup>-1</sup> + 3 kg Zn ha<sup>-1</sup>) (treatment combination) Table 2). On the other hand, the lowest concentration of nitrogen (5.74%) and phosphorus) 0.42 (% were found in at seeds of mungbean P<sub>0</sub>Zn<sub>0</sub> (No P + No Zn) treatment .Singh *et al.* [14] found significant increase of nitrogen concentration in mungbean due to the application of increasing level of P fertilizer.

**Potassium and sulphur concentration in seed:** The highest concentration of potassium (2.21%) and sulphur (0.65%) were

recorded in seeds at P<sub>2</sub>Zn<sub>2</sub> (20 kg P ha<sup>-1</sup> + 3 kg Zn ha<sup>-1</sup>) (treatment combination) Table 2). On the other hand, the lowest concentration of potassium (1.16%) and sulphur) 0.246 (% were found in seeds at P<sub>0</sub>Zn<sub>0</sub> (No P + No Zn) treatment combination . Singh *et al.* [14] found significant increase of potassium concentration in mungbean due to the application of P and Zn.

**Zinc concentration in seed:** There was no significant effect of combined application of P and Zn on the zinc concentration in mungbean seeds (Table 2). The highest concentration of zinc in the seeds (0.008 %) was recorded with the P<sub>2</sub>Zn<sub>2</sub> (20 kg P ha<sup>-1</sup> + 3 kg Zn ha<sup>-1</sup>) treatment combination which may be due to the higher supply and subsequent assimilation of this element in the seeds. It was observed that the lowest zinc concentration (0.004 %) in seeds was in P<sub>0</sub>Zn<sub>0</sub> (No P + No Zn) treatment combination.



**Table 2. Interaction effects of phosphorus and zinc on N P K S and Zn concentrations in mungbean seeds**

Interaction of P and Zn	N %	P %	K %	S %	Zn %
P <sub>0</sub> Zn <sub>0</sub>	5.74 h	0.42 f	1.16 h	0.246 f	0.004
P <sub>0</sub> Zn <sub>1</sub>	6.79 cd	0.47d-f	1.24 g	0.340e	0.005
P <sub>0</sub> Zn <sub>2</sub>	6.97 b	0.53 b-d	1.24 g	0.426 cd	0.005
P <sub>1</sub> Zn <sub>0</sub>	6.22 f	0.49 c-e	1.46 f	0.390 de	0.006
P <sub>1</sub> Zn <sub>1</sub>	6.28 f	0.52 b-d	1.62 e	0.463 c	0.006
P <sub>1</sub> Zn <sub>2</sub>	7.05 b	0.53 bc	1.77 d	0.556 b	0.007
P <sub>2</sub> Zn <sub>0</sub>	6.75 d	0.51 cd	1.57 e	0.356 e	0.007
P <sub>2</sub> Zn <sub>1</sub>	6.85 c	0.63 b	1.91 c	0.560 b	0.007
P <sub>2</sub> Zn <sub>2</sub>	7.46 a	0.69a	2.21 a	0.650 a	0.008
P <sub>3</sub> Zn <sub>0</sub>	6.59 e	0.49c-e	1.91 c	0.393 de	0.007
P <sub>3</sub> Zn <sub>1</sub>	6.55 e	0.61 b	2.07 b	0.463 c	0.006
P <sub>3</sub> Zn <sub>2</sub>	6.10 g	0.44 ef	1.62 e	0.440 cd	0.005
LSD <sub>(0.05)</sub>	0.0927	0.053	0.0535	0.0535	NS

In a column figures having similar letter(s) do not differ significantly whereas figures with dissimilar letter(s) differ significantly. NS: Non significant

#### IV. CONCLUSION

Nutrient concentration (N, P, K, S and Zn) in stover and seed were positively affected due to P and Zn fertilization. The interaction effect of P and Zn was also found remarkable. The N, P, K, S and Zn concentration in stover and seeds also increased with increasing level of P and Zn up to certain level. Based on the results of the present study, the following recommendation may be drawn - Application of Phosphorus and Zinc fertilizers @ 20 kg P ha<sup>-1</sup> and 3 kg Zn ha<sup>-1</sup> (P<sub>2</sub>Zn<sub>2</sub>) may be the best combination for higher nutrient concentration of mungbean stover and seed and also to maintain soil fertility and productivity than their individual application in Tejgaon series under AEZ No.28 in Bangladesh. Recommendation may vary from soil to soil.

#### REFERENCES

- [1] Kaul, A. K. (1982). Pulses in Bangladesh. BARC, Farm Gate. Dhaka. p. 27.
- [2] BARI. (1998). Mungbean Cultivation in Bangladesh. A booklet in Bengali. Bangladesh Agril. Res. Ins., Joydebpur, Gazipur.
- [3] BBS. (2010). Statistical Year Book of Bangladesh. Statistics Division, Ministry of Planning, Government of the Peoples Republic of Bangladesh. Dhaka. pp: 64-79.
- [4] Frauque, A., Haraguchi, T., Hirota, O. and Rahman, M. A. (2000). Growth analysis, yield, and canopy structure in maize, mungbean intercropping. Bu. Inst. of Tropical Agric. Kyushu University Fukuoka, Japan, 23: 61-69.
- [5] Khan, M. R. I. (1981). Nutritional quality characters in pulses. In: Proc. MAT. Workshop Pulses. pp. 199 -206.
- [6] Sangakara, U. R., Frehner, M. and Nosberger, N. (2001). Influence of soil moisture and potassium fertilizer the vegetative growth of mungbean (*Vigna radiata* L.). *J. Agron. Crop Sci.* 186(2): 73-81.
- [7] Coleman, J.E. (1991). Zinc proteins: Enzymes, storage proteins, transcription factors and Replication Proteins. *Ann. Rev. Biochem.* 61: 897-946.
- [8] Romheld, V. and Marschner, H. (1991). Function of micronutrients in plants. *Micronutrients in Agriculture*, In JJ Mortvedt, FR Cox, LM Shuman,

RM Welch, eds, Ed 2. Soil Science Society of America, Madison, WI, pp. 297-328.

- [9] Obata, H., Kawamura, S., Senoo, K. and Tanaka, A. (1999). Changes in the level of protein and activity of Cu/Zn Superoxide dismutase in Zinc deficient rice plants. *Oryza savita* L. *Soil Sci. Plant Nutr.* 45: 891-896.
- [10]
- [11] Haider, Hassan, M., Ahmad, F. and Mushtaq, F. 1991. Role of physiomorphic characters imparting resistance in cotton against some insect pests. *Pak. Entomol.*, 21: 61-66.
- [12] Gomez, K. A. and Gomez, A. A. 1984. *Statistical Procedures for Agricultural Research* (2nd Edn.). John Wiley and Sons, Singapore, pp. 28-92.
- [13] Prasad, J. and Ram, H. (1986). Effect of zinc and copper and Rhizobium inoculation on phosphorus availability and uptake in mungbean. *India J. Soc. Soil Sci.* 34(4): 762-766.
- [14] Singh, A. P., Chaudhury, R. K., and Sharma, R. P. R. (1993). Effect of inoculation and fertilizer levels on yield, nutrient uptake and economics of summer pulses. *J. Potassium Res.* 90: 176-178.

#### AUTHORS

**First Author and Corresponding Author:** A. Barman, Scientific Officer, Bangladesh Agriculture Research Institute, Joydepur, Gazipur-1701, Bangladesh, E-mail: hemkhairulmazed@gmail.com

**Second Author:** M. J. Chowdhury, B. Sc. Ag. (hons), Sher-e-Bangla Agricultural University, Dhaka-1207, Bangladesh,

**Third Author:** T. S. Mahabub, B. Sc. Ag. (hons), Sher-e-Bangla Agricultural University, Dhaka-1207, Bangladesh,

**Fourth Author:** M. Quamruzzaman, B. Sc. Ag. (hons), Sher-e-Bangla Agricultural University, Dhaka-1207, Bangladesh,

**Fifth Author:** A. Mondul, B. Sc. Ag. (hons), Sher-e-Bangla Agricultural University, Dhaka-1207, Bangladesh



# The Implementation of Recovery: A Literature Review

Mundakir\*

Student of Doctoral Program Degree, Faculty of Public Health Universitas Airlangga

\*Lecturer of Faculty of Health Sciences Universitas Muhammadiyah Surabaya

Jl. Sutorejo No. 59 Surabaya, Jawa Timur

**Abstract- Introduction:** Relapse happening to mental health illness patients showed that the healing process is not well implemented and has an impact on productivity. Recovery based service systems have been implemented in developed countries but has not performed optimally in developing countries. Implementation of psychiatric nursing care is only focused on comprehensive medication treatment. The purpose of the literature review is to describe model applied in psychiatric nursing in over coming relapse.

**Method:** The study used 17 articles that met inclusion criteria. Those articles retrieved 326 articles from different databases for example Scince Direct, Google Scholar, Springer Link, Pro Quest, and Ebsco Host using search article strategy approach and different key words, such as mental illness, recovery, models, and nursing intervention.

**Result:** Recovery has been widely applied in developed countries with various theories as a basis, such as combination between ecological theory and Family Maternal Therapy (FMT), Re-oriented System of Care (ROSC), Collaborative Recovery Model (CRM), Tidal Model, and Recovery Oriented Mental Health (ROMH) program by focusing on patient. In addition, there are different patterns of application recovery: (1) horror-outrage-right indignation; overconfidence; integration and balance; and creative implementation, and (2) attention to aspects of the organization and officers.

**Discussion:** Service system based on recovery consists of preventive, treatment and support in accordance with the need of the individual. Recovery approach needs to be applied in Indonesia comprehensively. In order to achieve that the effectiveness perspective of individuals, groups, and organization should be managed.

**Index Terms-** Recovery, Implementation, Mental Health Illness

## I. BACKGROUND

Mental health problems in the community continue to increase. Increasing this problem can be viewed from incidence and prevalence. Based on data from Basic Health Research-Riskesdas in 2013, the prevalence of severe mental disorder occurring in the city of Surabaya is 0.2 percent and the emotional disorders reaches 14.7 percent. The data is predicted to increase gradually and shows the phenomenon of the "iceberg". Medical records Menur Psychiatric Hospital Surabaya reports that the number of admitted patients to hospital re-constantly increase as seen on table 1:

**Table 1: The number of mental illness patient year 2011-2013 based on initial new admission and relapse admission**

Patient Category	Year Period (number of people)		
	2011	2012	2013
Initial new admission	1.102	1.135	1.010
Relapse admission	1.173	1.325	1.572

Source: Medical Record Menur Hospital Surabaya

The above data shows that the number of relapse patients is higher than new patients. This shows that trend of relapse rate of mental patients is still high. In terms of mental patients, World Health Organization (WHO) explained that the impact of mental health problems can lead to the loss of productive time for patients. The WHO predicts that the loss of productive time due to mental and neurological disorders in 2020 will increase by 15% compared to 12.3% in 2000 (MOH, 2003). Relapse patients with psychiatric disorders might be caused by unoptimally of the healing process such as individual patients, families support, or the implementation of service system.

In the implementation of service system nurses are one of health professionals who take a part in the system. Nurses performed varies nursing intervention such as group activity therapy, behavior therapy, therapeutic modalities, but the knowledge, skills, abilities related to recovery can not be explained considering the organization's recruitment process does not require the knowledge, attitudes, and skills about recovery in the recruitment of employees as described by Farkas et.al (2005).

Health care system in developing countries particularly Indonesia seems not implementing recovery. The implementation of nursing care provides comprehensive treatment and rehabilitation services to patients by emphasizing on continuity of care. There is a packet of information, but the information does not focus on the patient or no person orientation. This phenomenon contradicts developed countries such as UK, USA, New Zealand, and Australia that have implemented recovery-based service system because of the effectiveness and cost effective (Gehart, 2012). Furthermore, Davidson & White (2007) explain that comprehensive system recovery needs to be implemented and integrated in a national agenda in order to achieve the system optimal mental health services.

Recovery-oriented service system is a framework to coordinate from a wide variety of systems, services and support

focusing on individuals to find a way to recovery (Kaplan, 2008). The system consists of preventive, treatment, and support which meet individual needs. This is supported by Gehart (2012), recovery system will increase the strength of individuals, families, and communities to take responsibility in maintaining health status, well-being and the system is centered on the individual patient. Recovery-oriented services is considered to be on time and responsible, effective, equitable, and efficient, safe, and reliable, and maximum use of natural support (SAMHSA, 2012). Based on the above fact, research question used as the basis for the literature review in this study is how the model applied in nursing people in developing countries in overcoming relapse or recovery.

## II. METHODOLOGY

This literature review is conducted into several stages beginning with formulating research question, implementing article search strategy, reviewing articles, and then writing the results (Joan, 2007).

### *Article search strategy*

Based on the above formulation of research questions, researcher conducted article search strategy in several electronic data bases that are Science Direct, Google Scholar, Springer Link, Pro Quest, and Ebsco Host by writing the keywords *mental health, illness, recovery, models, nursing intervention, developing countries*. Researcher also combined keywords using Boolean logic is: and or and phrase searching. In addition, researcher also restricted articles based on year 2009-2013, and English. Using keywords developing countries, the results obtained are very limited. Due to the limitation researcher expanded the keyword with the developed countries and high income countries then retrieved 326 articles. The articles then included into 17 articles based on inclusion criteria (Denise F Polit, Sally Northam, 2011). To gain an understanding of the recovery models in the recovery model, researcher provided the summary of article.

## III. RESULT AND DISCUSSION

To discuss the results of this article, researcher used thematic analysis based on the topic headings of each article as well as using books to support the results. The results of the identification of gaps obtained one theme that is perspectives on the application of the model of recovery.

### *Perspectif of the implementation of model recovery*

The term recovery in mental health has undergone many changes since 1980 to the 21st century (Barker and Barker 2011). In general, recovery in patients with severe mental disorder is defined as a patient in an attempt to get his life back and the recovery process is often indicated by symptoms reduction and how patient can live meaningful in society (The US Department of Health and Human Services, 2004). This differs from Gehart (2012). Gehart (2012) explained that the recovery is a paradigm, in which recovery can be one of the alternative models in conceptualizing mental health. Recovery paradigm emphasis on

the social model of psychosocial functioning over medical treatment. However, the recovery paradigm is not a model of rejecting medical treatment or diagnosis. While Barker (2011) in the Tidal theory describes that recovery as an activity that leads patient to have intervention based on individual characteristic or patient needs such as balance between activity and rest, mental preparation for the next activity, and the need to relinquish control of aspects of his life so that the patients become more healthy and ready to move in everyday life. This situation is becoming the biggest challenge in mental health today because there is the lack of knowledge about the services and interventions that helps patients recover and attempts to not have a relapse or recovery towards more severe mental disorders (Farkas, et al 2005) although Gehart (2012) explained that the implementation of recovery may enhance the effectiveness in the treatment of mental health patients and can save maintenance costs.

Focusing on the implemenation of recovery, there are recovery elements that will be associated with a number of recovery models that have been developed by many health workers in different situations and population. Some model of recovery approaches are ecological theory and maternal family therapy (FMT), recovery-oriented mental health (ROMH) programs, the implementation of recovery-oriented systems of care (ROSC), collaborative recovery model (CRM), tidal model (Gehart, 2012; Davidson & White, 2007; Oades, et.al 2005; Barker & Barker, 2011; Farkas et.al 2005).

Onken in Gehart (2012) explains that the incorporation of ecological theory and maternal family therapy. The model has basic recovery framework that is the ecological perspective on how individual characteristics interact with the environment. In ecological theory, there are four elements that are used to support the recovery models, namely: (1) person-centered: activities undertaken at this stage is to develop a mindset in viewing expectations or "hope" to patients, other colleagues, family, and friends, sense of agency, self-determination, meaning and purpose, awareness and potential by including religious beliefs and patients. This stage is the most severe stage because it depends on the individual development therapist in related to minimize the provision of health education (Gehart, 2012); (2) re-authoring: a major thing in the recovery process where family therapist will use the elements of collaboration, narrative, and cognitive therapy (Gehart, 2012); (c) exchange-centered: this element helps the individual to have a role in the community, often involving peer advocates or individuals who help start the journey in recovery, give hope and a role model for the early recovery process (Gehart, 2012); and (d) community-centered elements: providing community support in the form of social connections and relationships in the community. Recovery-based care in the context of family therapy aims to help individuals in rebuilding relationships to increase intimacy and social support (Gehart, 2012).

ROMH program is characterized as a structured program that consists of mission, policies, procedures, medical records and quality assurance (Farkas, et.al, 2005). This characteristic consistent with the basic values of recovery explained by Gehart that is patient centered by emphasizing on narrative elements, meaning, choice, and hope (Gehart, 2012; Farkas, et.al, 2005). In detail, the values of ROMH program consists of person

involvement, self-determination, and growth potential. Focusing on the person involvement, this program gives the rights of individuals to participate actively in planning, implementing and evaluating patient recovery support services (Farkas, et.al, 2005). In recovery-oriented system of care (ROSC) mentions "hope" as a core in fostering recovery. Hope in this system includes the patient's values and beliefs as an individual patient (Gillburt, 2013). Besides hope, Gillburt also explained that the involvement and partnership working is crucial in helping patients to perform recovery as mentioned by previous researchers (Gilburt, 2013; Gehart, 2012; Farkas et.al, 2005). Furthermore, ROSC involves multidisciplinary work. This can support inter-professional learning in related to obtain more effective approach to the work. This system of care is similar as collaborative recovery model (CRM) developed by Oades (Gilburt, 2013; Oades et.al, 2005). Furthermore, Gilburt (2013) describes that training and workshop in changing the perspective and work system in implementing the system recovery is needed. Associated with working in a multidisciplinary, CRM mention there are four components that must be applied in the implementation of the recovery, namely: (1) change enhancement, (2) collaborative needs identification, (3) collaborative goal setting and striving, and (4) collaborative task assignment and monitoring (Oades et.al, 2005). Component change involves motivational enhancement (ME) and cognitive. Motivational enhancement is a form of counseling and technique that aims to motivate individuals to change. This change involves several cycles through the stages before the individual can perform self-management actively. In ME, physician will help to identify the benefits and disadvantages of settling behavior of existing and planned behavior. Next is a cognitive capacity, physicians are encouraged to adapt their practices to optimize communication and collaboration with the patient's cognitive capacity by putting in the values. Cognitive elements and collaboration in the concept of CRM has similarity to the integration of ecological theory and FMT (Oades, et. Al, 2005; Gehart, 2012). The second component of the CRM is the collaborative needs identification which in this component explains that unmet needs are a key source of motivation for individuals with mental illness and Camberwell Assessment of Need Short Appraisal Schedule (CANSAS) is used for the measurement of the needs assessment and collaboration purposes. The next component of the CRM is the collaborative goal setting and striving. At this stage the doctor and patient collaborate to develop the vision of recovery of individuals, and then continued implementing collaborative task assignment and monitoring to identify and overcome barriers to implementation (Oades et.al, 2005).

Tidal Model is a philosophical approach to mental health recovery. This model is active element which nurse educator in interdisciplinary team plays an important role in planning, problem solving, and promoting mental health through the narrative (Tomey & Alligod, 2006). Tidal model emphasis nurses to understand the meaning of mental health for psychiatric patients who experienced treatment and how patients can be helped to start recovery as a whole besides emphasizing on patient's life experience, and narrative intervention. Empirically it can be concluded that the core objective of tidal model is self-determination through participation and collaboration as keys. In addition,

There are 10 commitments from Tidal theory: (1) value; (2) respect the language; (3) develop genuine curiosity; (4) become the apprentice; (5) reveal personal wisdom; (6) Be transparent; (7) use the available toolkit; (8) Craft the step beyond; (9) give the gift of time; (10) know that change is constant. Furthermore, in this theory there are six (6) principles guiding the recovery, namely: curiosity of individuals in the world have the authority to his own life, resourcefulness focused and work with less resourcefulness of individuals, the resources of individuals, resources, interpersonal and social network, respect for the person's wishes expectations of the individual at the center of care, crisis as opportunity, a natural sign of something to do, a chance to change, taking the instructions of living in life, think small goals to be achieved are small and specific, simple elegance intervention possibilities for change (Tomey and Alligod, 2006).

There are several studies on the application of recovery (Barker & Barker, 2011; Davidson & White, 2007; Farkas, et.al, 2005; Gehart, 2012). In general, the results of research explain about the principles of patient-focused care. In addition, Gehart (2012) that there are four phases in adopting recovery, namely: (1) the horror, outrage, and indignation right: at this stage the therapist requires modification and expand the practice of recovery; (2) overconfidence: this phase emphasizes the social function by maintaining relationship, social life and the lives of individuals. In this phase it is also important to identify which aspects of the general recovery that can be part of the care; (3) integration and balance: how to integrate the recovery paradigm in the world of work; (4) creative implementation: health officials develop new approaches, strategic, formats that have not been found based on the principles of recovery. Gehart steps can be expanded by using the concept of Farkas, et.al (2005). Farkas describes a more systematic pattern in the implementation of recovery by dividing into two dimensions, namely: (1) the dimensions of the organization or administration, and (2) the dimensions of the officer or caregiver.

#### IV. CONCLUSION AND RECCOMENDATION

Service system based on recovery consists of preventive, treatment and support in accordance with the need of the individual. In general, several studies explain about the principles of patient-focused care. Patient focused care can be classified into survival needs growth needs; and self actualization needs. So, patients are processed by utilizing nursing knowledge about recovery in order to achieve how patients can be restored back to health, then the hospital is effective. If the nurse as a health worker is able to empower every patient based on his or personal characteristic, patient can live optimally in the society and patient satisfaction can be met. However, it may be not fully in Indonesia. Understanding best evidence from develop countries shows that the implementation of recovery system is effective and low cost. So, this program could be a benchmark target for Indonesia. Recovery system needs to be applied in Indonesia comprehensively. In order to achieve that the effectiveness perspective of individuals, groups, and organization should be managed in particular nurses. Indonesian nurses should be managed by training and workshop on recovery. Then,

developing on the implementation of recovery model needs to be investigated as recommendation.

#### REFERENCES

- [1] Alligod, A. M. (2010). *Nursing Theory Utilization and Application*. Mosby Elsevier, USA.
- [2] Barker Phil J, Barker Poppy Buchanan. (2011). *Mental Health Nursing and the Politics of Recovery: A Global Reflection*. *Archives of Psychiatric Nursing*, 25(5), 350-358.
- [3] Brog W.R and Gall, M.D. (1983). *Educational Research*. New York: Longman.
- [4] Creswel, J. W. (2008). *Qualitative Inquiry and Research Design: Choosing among Five Traditional*. USA: Sage Publication, Inc.
- [5] Davidson Larry, White William. (2007). *The Concept Recovery as an Organizing Principle for Integrating Mental Health and Addiction Service*. *Journal of Behavioural Health Services and Research*, 34(2), 1094-3412.
- [6] Denise F Polit, Sally Northam. (2011). *Impact Factors in Nursing Journals*. *Nursing Outlook*, 59, 18-28.
- [7] Farkas M, Gagne Cheryl, Anthony William, Chamberlin Judi. (2005). *Implementing Recovery Oriented Evidence Based Programs: Identifying the Critical Dimensions*. *Community Mental Health Journal*, 41(2), 141-156.
- [8] Gehart, D. R. (2012). *The Mental Health Recovery Movement and Family Therapy, Part:I Consumer-Led Reform of Services to Persons Diagnosed with Severe Mental Illness*. *Journal of Marital and Family Therapy*, 38(3), 429-442. Dipetik 2013
- [9] Gibson, J.L., Ivancevich, J.M., Donnelly, James, J.R. (1996). *Organisasi Perilaku Struktur Proses*. Jakarta: Binarupa Aksara, Indonesia.
- [10] Gilbert Helen, Slade Mike, Bird Victoria, Oduola Sheri, Craig KJ Thom. (2013). *Promoting Recovery Oriented Practice in Mental Health Service: a Quasi-experimental Mixed Method Study*. *BMC Psychiatry*, 13(167), 1-10.
- [11] Joan, T. B. (2007). *Research in Nursing and Health Care: Creating Evidence for Practice*. Nelson Australia Pty Limited.
- [12] Kaplan, Harold I. ; Sadock, Benjamin J. (1991). *Synopsis of Psychiatry Behavioral Sciences Clinical Psychiatry*. Williams & Wilkins, USA.
- [13] McEvoy Phil, Schauman Oliver, Mansell Warren, Morris Lydia. (2012). *The Experience of Recovery from the Perspective of People with Common Mental Health Problems: Findings from a Telephone Survey*. *International Journal of Nursing Studies*, 49, 1375-1382.
- [14] Oades Lindsay G, Deane Frank P, Crowe Trevor P, Lambert W. Gordon, Kavanagh David. (2005). *Collaborative Recovery: An Integrative Model for Working with Individuals who Experience Chronic and Recurring Mental Illness*. *Australian Psychiatry*, 13(3), 279-284.
- [15] Sklar Marisa, Groessl Erik, O'Connell Maria, Davidson Larry, Aarons A. Gregory. (2013). *Instruments for measuring mental health recovery: A systematic review*. *Clinical Psychology Review*, 33, 1082-1095.
- [16] Tomey Ann Marriner., Alligod Martha Raile. (2006). *Nursing Theories and Their Work*. Mosby Elsevier, USA.
- [17] U.S, Department of Health and Human Services. (2004). *National Consensus Statement on Mental Health care in America*.

#### AUTHORS

**First Author** – Mundakir, Student of Doctoral Program Degree, Faculty of Public Health Universitas Airlangga, \*Lecturer of Faculty of Health Sciences Universitas Muhammadiyah Surabaya, Jl. Sutorejo No. 59 Surabaya, Jawa Timur, Email: cak\_mudz@yahoo.co.id



# Climate Change and Rice Yield in Bangladesh: A Micro Regional Analysis of Time Series Data

A. H. M. Monzurul Mamun\*, Bikash Chandra Ghosh\*\*, S.M. Rayhanul Islam\*\*\*

\* Department of GEUP, Pabna University of Science & Technology, Pabna-6600, Bangladesh.

\*\*Department of Economics, Pabna University of Science & Technology, Pabna-6600, Bangladesh.

\*\*\* Department of Mathematics, Pabna University of Science & Technology, Pabna-6600, Bangladesh.

**Abstract-** The study examines the trend of three main climatic variables (eg. Temperature, Rainfall and Relative humidity) for Rajshahi, Bangladesh by using the time series data for the 1972-2010 period and assesses the relationship between the variables and the yield of three major rice crops (eg. *Aus*, *Aman* and *Boro*). The results of Ordinary Least Squares (OLS) reveal the significant effects of climatic variables on rice yields and these effects vary among the three rice crops. Increase in Temperature and Relative humidity and decrease in Rainfall have both positive and negative effects on the yield. The three climatic variables can explain 23, 91 and 89% of the variance in *Aus*, *Aman* and *Boro* production. The study also evaluates the local knowledge and resource based adaptation techniques adopted by the farmers. Different coping mechanisms like change in transplantation time, cropping pattern change, digging of ponds, selection of short duration species etc are being adopted to minimize the impacts of climatic variations on rice production. Necessity and development of temperature tolerant *Aman* and *Boro* rice varieties and farmer's adaptive strategies are prominent.

**Index Terms:** Climate change, Climatic variation, Rice yield, Adaption and Bangladesh.

## I. INTRODUCTION

Climate is considered as the major controlling factor of life on earth which is continuously changing due to natural forces as well as anthropogenic activities like land use changes and emission of greenhouse gases and aerosols. Atmospheric temperature, rainfall, humidity, solar radiation etc. are dominant climatic factors closely linked with agricultural production that forms the economic base of underdeveloped Bangladesh which is considered as the most vulnerable country facing climate change (Basak, 2011). Agricultural production in Bangladesh is always vulnerable to unfavorable weather events and climatic conditions. Modern technological developments such as improved crop varieties and irrigation systems attempt to change the scenario but still weather and climate are important factors to play a significant role to agricultural productivity. The impacts of climate change on food production are major environmental concerns of this agriculture dominated economy. Earth's atmospheric temperature has been in an increasing trend since the 1980s and the average surface temperature has increased by about 0.15 to 0.2 °C in the last 100 years (Mendelshon, 2007). With the potential increase in temperature, rainfall has already become variable and unpredictable and the extreme climatic events (eg. Floods, droughts, heat waves and cyclones) are frequent. Bangladesh faces an increase in average day temperature for the last three decades and the number of days without rain is also increasing which results in an uneven distribution of rain and extreme events like flood and drought (Sarker et al., 2012). This climatic variability has adverse effects on paddy rice and it is the most important dietary component of Bangladeshi people.

Rice is the dominant agricultural product of Bangladesh which covers about 80% of the total cropped area and accounts for more than 90% of total grain production (Asaduzzaman et al., 2010). The agro economic contribution is 20% of the Gross Domestic Product (GDP) and almost 66% of the labour force depends on agriculture for employment (GOB, 2010). Agricultural sector of this country is already under pressure with the continuously changing climate, land and water resource depletion and faces challenges in providing food security to its increasing population. Dependency of livelihood on agriculture reveals the necessity of assessing the climate change effects on rice production to ensure food security and economic development. Therefore, the objective of this study is to assess the empirical relationship between three climatic variables and rice yields of three crops using time series data over the period from 1972-2010 for Rajshahi District of Bangladesh.

## II. MATERIAL AND METHODS

Both primary and secondary data were collected to complete the study. Primary data were collected during May to June, 2014. The study area was Tanore Upazila of Rajshahi District of Bangladesh located between 24°29' and 24°43' north latitudes and between 88°24' and 88°38' east longitudes. It has an area of 295.39 square kilometers lies in Barind tract consists of high terrace and valleys free from seasonal flooding (banglapedia.org). The average annual temperature is 25.7°C and rainfall is about 1407 mm (en.climatic-data.org). River Shiba flows by the eastern side of this region. Four villages of Tanore upazila namely Badhair, Kalma, Kamargaon



and Saranjai were selected. Multistage sampling was used to select the said four villages for this observational study. Rajshahi was selected for a handful of reasons. First and foremost, this district of Bangladesh is severely affected by extreme climate events viz., extreme heat waves and cold waves. Furthermore, it is one of the drought prone areas of Bangladesh. A semi-structured questionnaire, in-depth interview, and focus group discussion (FGD) were used to collect information according to the objectives of the research. On the basis of the Kothari, 2006 formula, 200 household (50 from each four villages) is drawn as sample size by random sampling technique from the total 1600 household which is 10% of the total household at 95% confidence level. The climatic data related to rainfall, average temperature and relative humidity were collected from the secondary sources of Bangladesh Meteorological Department, Dhaka for Rajshahi weather station which covers the period of 1972-2010. Rice yield data by variety for the same time period (1972-2010) were obtained from various issues of the Bangladesh Economic Review (GOB, 1991, 2001, 2010). Various climatic data were processed according to the seasonal variation to evaluate the climate variability accurately as much as possible. Average of month of respective data was calculated from the time series data. Then the data were processed for the following three growing seasons (Sarker et al., 2012).

- *Aus Growing Season (March-August)*: This season is characterized by high temperature and evaporation of pre monsoon summer with occasional thunderstorms and the intensive rainfall of the early months of monsoon.
- *Aman Growing Season (June-November)*: Production of this season is dominated by the regular intensive rainfall of monsoon, highly humid weather and cloudiness.
- *Boro Growing Season (December-may)*: This season is depicted as the driest and sunniest period of the year consists of the months of winter and pre monsoon summer.
- 

According to BRRI (1991), *Aus* rice requires supplementary irrigation during the initial stage of its growing season while *Aman* is almost completely rain-fed rice that grows in the months of monsoon, although it necessitates for supplementary irrigation during planting and sometimes in the flowering stage depending on the availability of rainwater. On the other hand, since *Boro* rice grows in the dry winter and the hot summer, it is thus completely irrigated (Mahmood, 1997).

The trend pattern was evaluated from the equation  $y=mx+c$ . where,  $m$  implies the rate or trend value per year and least square value  $R^2$  reveals the significance number to fit with the trend.

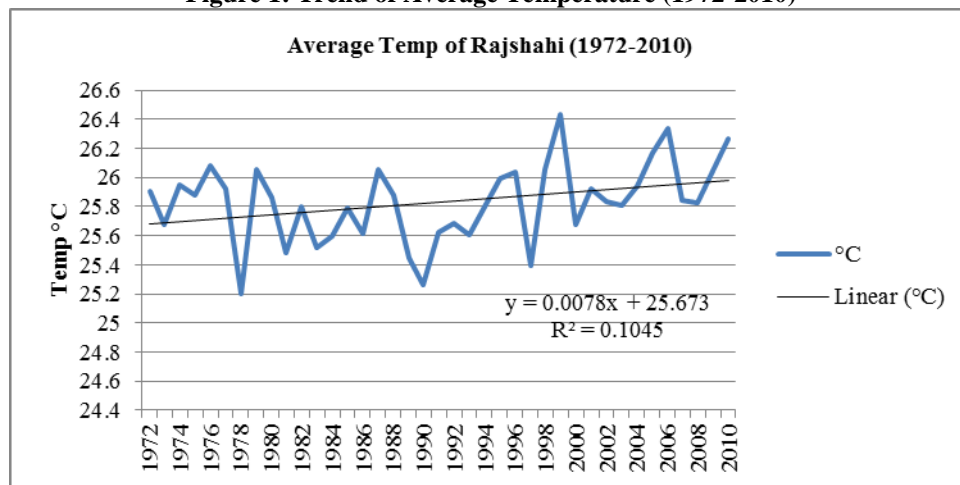
### III. RESULT AND DISCUSSION

#### 3.1 Trends of Climatic Variation

##### 3.1.1 Trend of Temperature

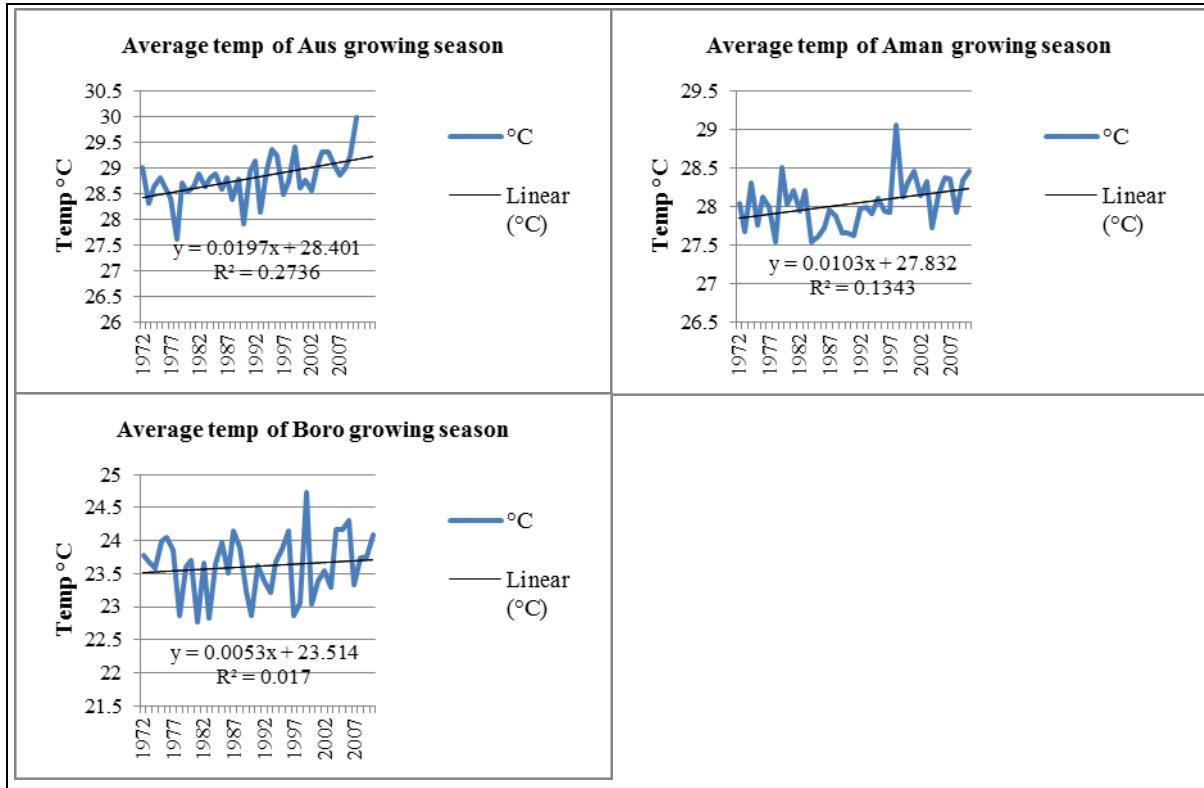
An overall increase in temperature is observed over the period of 1972-2010. The pattern of the temperature trend is irregular (Fig. 1) and the average temperature of this region is increasing at a rate of  $0.007^{\circ}\text{C}$  per year with an  $R^2$  of 0.104.

**Figure 1: Trend of Average Temperature (1972-2010)**



Positive trend is also observed in the temperature pattern of three rice growing seasons. The trend values of *Aus*, *Aman* and *Boro* growing seasons are  $0.019^{\circ}\text{C}$ ,  $0.01^{\circ}\text{C}$  and  $0.005^{\circ}\text{C}$  per year with respective  $R^2$  values of 0.27, 0.13 and 0.017 (Fig. 2)

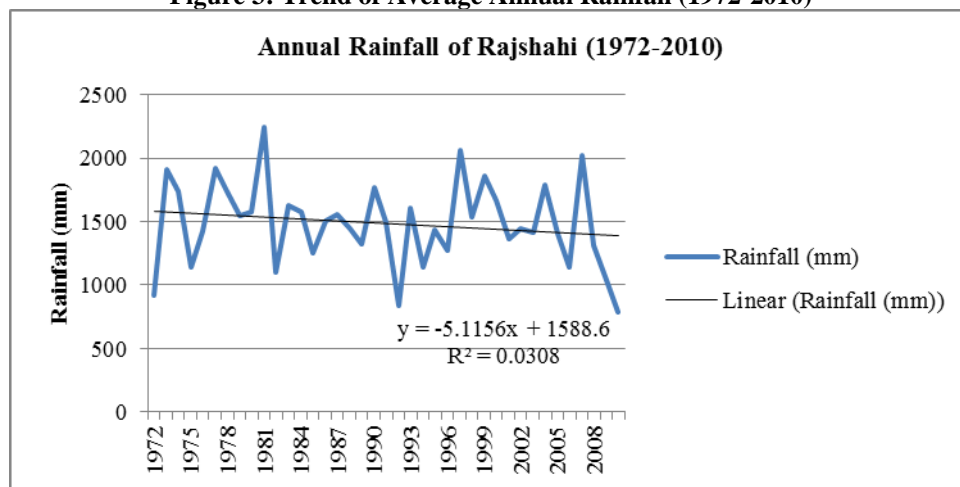
**Figure 2: Trend of Average Temperature of the Growing Seasons**



**3.1.2 Trend of Rainfall**

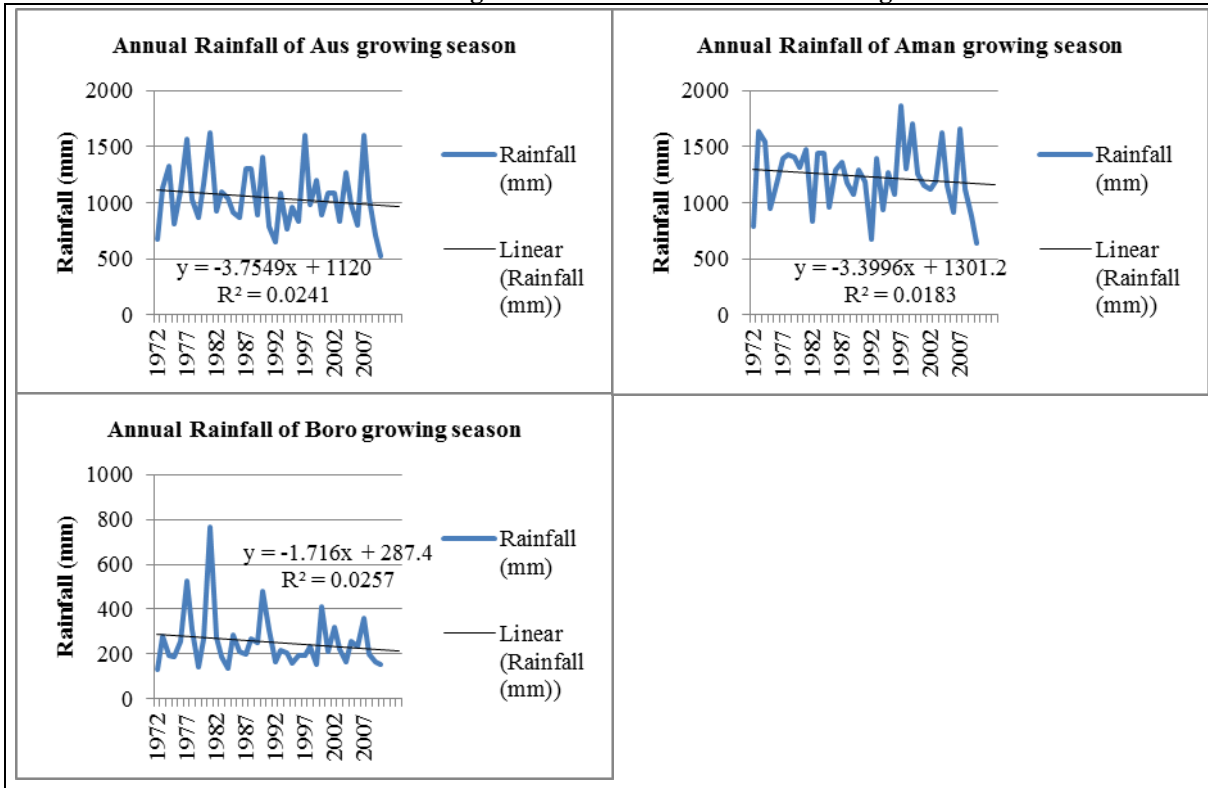
Rajshahi is one of the most drought prone areas of Bangladesh and the rainfall is comparatively lower than any other part of the country. The study finds that it shows a gradually decreasing trend over the period of 1972-2010 at a rate of 5.11 mm per year with an  $R^2$  of 0.03.

**Figure 3: Trend of Average Annual Rainfall (1972-2010)**



Rainfall pattern of different rice growing seasons is also showing a negative trend. Aus growing season has a decreasing rate of 3.75 mm per year, Aman and Boro have 3.39 and 1.71 mm per year respectively. Major portion of annual monsoon rain occur in Aman growing season but still it is showing a decreasing trend significantly affecting the yield. Boro growing season consists of the months of winter and pre monsoon summer. In tropical climate rainfall is apparently low in these two seasons. Variability in rainfall may affect Boro production. The  $R^2$  values for these three growing seasons are 0.024, 0.018 and 0.025 respectively.

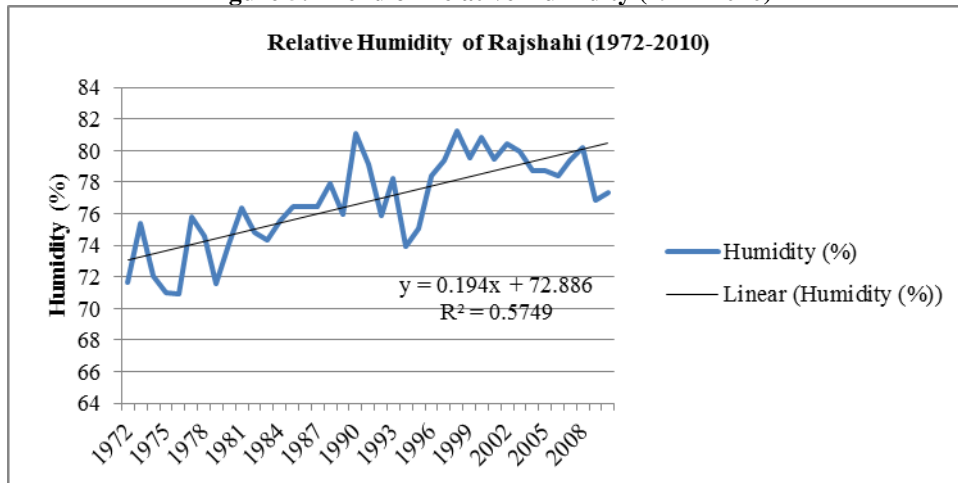
**Figure 4: Trend of Rainfall of Growing Seasons**



**3.1.3 Trend of Relative Humidity**

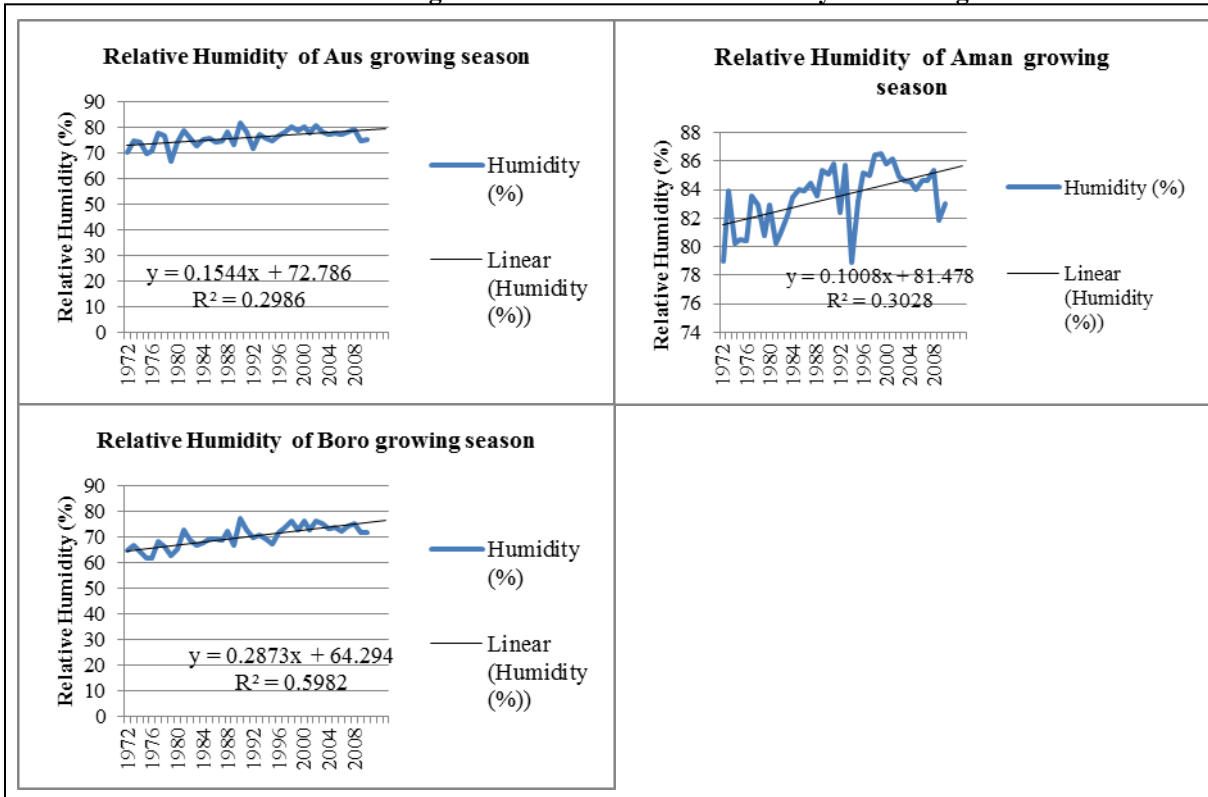
It is observed that the relative humidity of the study area is showing a comparatively higher increasing rate over the period of 1972-2010 with an increasing trend of 0.194% per year and an  $R^2$  of 0.574.

**Figure 5: Trend of Relative Humidity (1972-2010)**



Three growing seasons show increasing rate of 0.154, 0.100 and 0.287% per year with R2 values of 0.29, 0.30 and 0.59 respectively.

**Figure 6: Trend of Relative Humidity of Growing Seasons**



3.2 Correlation and Regression Analysis of the Climatic Variable and Crop Yield

3.2.1 Correlation Analysis

The correlation analysis is performed among the climatic variables and crop yield. The results are shown in Table 1.

**Table 1: The Correlation Analysis of Climatic Variables and Crop Yield**

Crop	Rainfall (mm)	Average Temperature (°C)	Relative Humidity
Aus	0.252	0.240	0.253
Aman	-0.081	0.313	0.534
Boro	-0.196	-0.204	0.488

Source: Authors' Own Calculation

The correlation analysis exposed the correlation between climatic variables i.e., rainfall, average temperature and relative humidity for the growing periods of crops under study [For *Aus* (March to August), for *Aman* (June to November), for *Boro* (December to May)]. From the table, rainfall is positively correlated with *Aus* (0.252), but negatively correlated with *Aman* (-0.081) and *Boro* (-0.196) which revealed that high rainfall is favorable for the *Aus* production. However, *Aman* is also depends on the monsoon rainfall but extensive rainfall is not required rather regular rainfall is important for the good production of *Aman*. Besides in the winter rainfall is almost not occurring in the selected study area and production is totally depends on supplementary irrigation.

Temperature has a positive weak correlation with *Aus* (0.240) and *Aman* (0.313) whereas a negative correlation with the *Boro* (-0.204). This result indicates that high temperature is negatively affected on the *Boro* production as high temperature increase the demand of water. The relative humidity has positive but weak correlation with the *Aus* (0.253), *Aman* (0.534) and *Boro* (0.488) which indicates that high relative humidity is helpful for the high production of crops as high relative humidity influence the plant development and photosynthesis of the leaves.

### 3.2.2 Regression Analysis

The regression analysis is also performed between the climatic variables and crop yield. List of variables used in regression model construction are as follows:

Dependent Variable	Independent Variable
<i>Aus</i> Paddy	Rainfall
<i>Aman</i> Paddy	Temperature
<i>Boro</i> Paddy	Relative Humidity

**Table 2: Result of Multiple Regression Analysis between Climatic Variables and Crop Yield**

Crops	R <sup>2</sup>	R <sup>2</sup> (Adjusted)	F Value	P Value
<i>Aus</i>	0.231	0.163	3.409	0.028
<i>Aman</i>	0.912	0.617	8.863	0.000
<i>Boro</i>	0.897	0.752	7.529	0.001

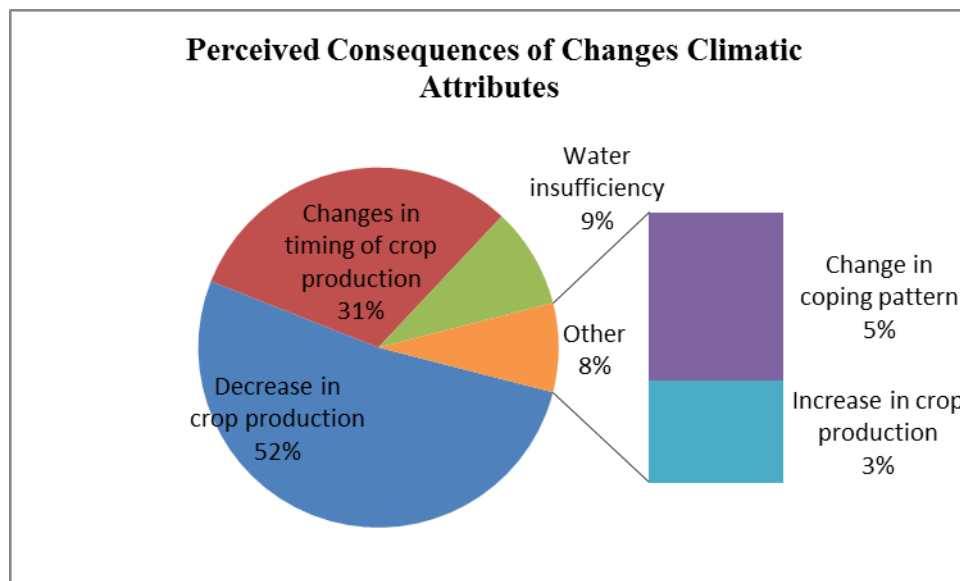
Source: Authors' Own Calculation

The regression analysis computed for the crops revealed that *Aus*, *Aman* and *Boro* have coefficient of determination of 0.23, 0.91 and 0.89 respectively. This indicates that 23, 91 and 89% of the variance in *Aus*, *Aman* and *Boro* can be explained by the independent parameters of the model. The implication is that 77, 9 and 11% of the variance in *Aus*, *Aman* and *Boro* explained by the other factors not included in the model. From the R<sup>2</sup> value it can be said that the crops yield values are lying closely in a straight line and showing a trend except *Aus* paddy, which scattered and lower fit in the trend. From the P value we can conclude that in *Aus*, *Aman* and *Boro* production there is a significant linear relationship between the dependent and independent variables as p value is less than 0.05.

### 3.3 Implications of Climate Change on Crop Production

The respondents were asked about the consequences of climate change on crop production. In that case, 52% of the respondents perceived a decrease in crop production due to climatic variability whereas 31% observed changes in timing of crop planting and harvesting. The other major impacts were water insufficiency, change in cropping pattern however, very few respondents also perceived increase in crop production. The perceived consequences attributed to changes in different above mentioned attributes of climate change are shown in figure 7.

**Figure 7: Perceived Consequences of Changes Climatic Attributes**



The local people perceived that crop damage due to increased pest attacks had increased. The farmers also reported on the emergence of new pests in crops and felt, it was an impact of increasing temperature along with the disturbance in the natural pest predator



system as a consequence of soil degradation due to unbalanced use of chemical fertilizers and pesticides. Consequently, the cost of production has been increasing while crop production is declining. Literature also showed that an increase in maximum temperature can enhance invasive weeds to enter the area (Dukes and Mooney, 1999). A decrease in the number of days with  $< 0^{\circ}\text{C}$  also can cause an increase in insects and pests because of less winter kill (Ziska et al., 2011).

### 3.4 Farm Level Adaption Strategy

In order to cushion the effects of climatic variability, farmers take different sorts of measures to adjust with the climatic variability. Their practices vary based on degree of vulnerability, awareness, perception, localities and affordability of resources (Alam et al., 2011). However, these options are very few in compare to the problem. Local farmers responded that they have changed their plantation time due to the seasonal variability. They are now transplanted *Aman* and *Boro* rice before June and January to ensure the rainfall. Moreover, farmers changed their coping pattern and more interested to selected water scarcity tolerant species. Apart from this they are also converting their agricultural land into mango garden as its not required supplementary irrigation. In this study, farmers have adopted a variety of adaptation strategies including change in planting date, setup shallow tube well in pond, short duration species selection, move to a different side, interlink with little *khal*, improved irrigation facility and agro forestry product.

**Table 3: Farmers Adaption Strategies**

	Adaptive Measures	No. of Respondent (%)
1.	Change in planting date	62%
2.	Setup shallow tube well in pond	54%
3.	Short duration species selection	41%
4.	Move to a different side	28%
5.	Interlink with little <i>khal</i>	21%
6.	Improved irrigation facility	18%
7.	Agro forestry product	12%
		N=200

Source: Field Survey, 2014

### IV. CONCLUSION

The objective of the study was to examine the relationship between climatic variables and rice yields using the time series data for the period of 1972 to 2010. The results of used OLS illustrate that three climatic variables have significant effects on the yield of three different rice varieties. Increase in temperature and humidity and the irregularity and gradually decreases in rainfall are statistically significant. Temperature maintains a negative correlation with *Boro* and the rainfall with *Aman* and *Boro*. The climatic variables explain 23, 91 and 89% of variance in *Aus*, *Aman* and *Boro* respectively. The P value indicates significant linear relationship between climatic variables and yield. To minimize the effects of the climatic variables farmers of the study area adopt some strategies like changing in planting date, digging of ponds and setting up shallow tube wells, selection of short duration species etc. based on indigenous knowledge and resources. The severe sensitivity of rice production to climatic variables reveals the necessity of further research and development of climate-resilient varieties and variety specific strategies to minimize the adverse effects of climate change. This study can be identified as an approach towards capturing regional climatic variations and obtaining a comprehensive picture of the issue of climate change and rice yield in Bangladesh.

### References

- [1]. Basak, J.K. (2011) Implications of Climate Change on Crop Production in Bangladesh and Possible Adaptation Techniques. In: International Conference on United Nations Framework Convention on Climate Change (UNFCCC), Durban Exhibition Centre, Durban, COP 17. Unnayan Onneshan - The Innovators, Dhaka-1215, Bangladesh.
- [2]. Mendelshon, Robert. "Past Climate Change Impacts on Agriculture". *Handbook of Agricultural Economics*. Vol 3. 2007, Ch.60 pp.3010-3030.
- [3]. Sarker, M.A.R, Alam, K. and Gow J. "Exploring the relationship between climate change and rice yield in Bangladesh: An analysis of time series data". *Agricultural Systems*, Elsevier. 112 (2012) 11-16.
- [4]. Asaduzzaman, M., Ringler, C., Thurlow, J., Alam, S., "Investing in Crop Agriculture in Bangladesh for Higher Growth and Productivity, and Adaptation to Climate Change". Bangladesh Food Security Investment Forum, Dhaka, 2010.
- [5]. Bangladesh Economics Review, 2009. Government of the People's Republic of Bangladesh. Ministry of Finance, Dhaka.

- [6]. [banglapedia.org](http://banglapedia.org)
- [7]. [en.climatic-data.org](http://en.climatic-data.org)
- [8]. Kothari, C. R., *Research Methodology*, 2<sup>nd</sup> Edition, New Age International (P) Ltd., 2006, New Delhi, India.
- [9]. GOB (Government of Bangladesh), 1991. *Bangladesh Economic Review*. Ministry of Finance, Dhaka, Bangladesh.
- [10]. GOB (Government of Bangladesh), 2001. *Bangladesh Economic Review*. Ministry of Finance, Dhaka, Bangladesh.
- [11]. GOB (Government of Bangladesh), 2010. *Bangladesh Economic Review*. Ministry of Finance, Dhaka, Bangladesh.
- [12]. BMD (Bangladesh Metrological Department), 2014. Data Collected from BMD Online Version on 1<sup>st</sup> December, 2014, Bangladesh.
- [13]. BRRI (Bangladesh Rice Research Institute), 1991. *Rice Yield and Environmental Data*, BRRI, Dhaka, Bangladesh.
- [14]. Mahmood, R., "Impacts of air temperature variations on the Boro rice phenology in Bangladesh: Implications for irrigation requirements", *Agric. For. Meteorol*, 84, 1997, 233-247.
- [15]. Dukes, J.S.; and Mooney, H.A., "Does global change increase the success of biological invaders?" *Trends in Ecology & Evolution* (4), 1999, pp: 135-139.
- [16]. Ziska, L., K. Knowlton, C. Rogers, D. Dalan, N. Tierney, M. Elder, W. Filley, J. Shropshire, L.B. Ford, C. Hedberg, P. Fleetwood, K.T. Hovanky, T. Kavanaugh, G. Fulford, R.F. Vrtis, J.A. Patz, J. Portnoy, F. Coates, L. Bielory, and D. Frenz. 2011. Recent warming by latitude associated with increased length of ragweed pollen season in central North America. *PNAS* 108, 2011, 4248–4251.
- [17]. M.M. Alam, C. Siwar, R.I.Molla, B. Talib, and M.E. Toriman., "Paddy farmers' adaption practices to climatic vulnerabilities in Malaysia", *Mitig. Adapt. Strateg. Glob. Chang.* vol. 17, no. 4, 2011, pp. 415-423.

#### AUTHORS

**First Author- A. H. M. Monzurul Mamun**, Lecturer, Department of Geography, Environment & Urban Planning, Pabna University of Science & Technology, Pabna-6600, Bangladesh. E-mail: [hasnat\\_pust@yahoo.com](mailto:hasnat_pust@yahoo.com)

**Second Author- Bikash Chandra Ghosh**, Lecturer, Department of Economics, Pabna University of Science & Technology, Pabna-6600, Bangladesh. Email: [bikasheco\\_pust@ymail.com](mailto:bikasheco_pust@ymail.com)

**Third Author- S. M. Rayhanul Islam**, Lecturer, Department of Mathematics, Pabna University of Science & Technology, Pabna-6600, Bangladesh. E-mail: [rayhanulmath@yahoo.com](mailto:rayhanulmath@yahoo.com)

**Corresponding Author- Bikash Chandra Ghosh**, Lecturer, Department of Economics, Pabna University of Science & Technology, Pabna-6600, Bangladesh. Email: [bikasheco\\_pust@ymail.com](mailto:bikasheco_pust@ymail.com)

# Better Life: Perceptions of Happiness in the Capital of Latin America

Patricia Iturriaga, B.S., Toni DiDona, Ph.D

Carlos Albizu University

**Abstract-** Most individuals in the US spend a significant amount of time at work. Happiness at work becomes an important element of an individual's overall happiness. Some findings suggest that job satisfaction can be determined by each person's internal characteristics and not necessarily due to the employer. These internal characteristics may be related to culture. Miami is a city with a large Latino immigrant community. It was hypothesized that there is a significant difference between Latino immigrants and born-in-America individuals in their perception of happiness at work. In addition, it was also hypothesized that there is a significant correlation between the perception of happiness at work and the individual's acculturation level. This research study utilized 100 respondents, who were selected via convenient quota sampling. The sample was divided into two groups according to their immigration status: Latino immigrants, and individuals who were born in America. Participants were given a questionnaire with 25 items intended to measure perception of happiness at work, acculturation level, and demographic information. A t-test and a correlation were used to test the hypotheses. However neither of these hypotheses were confirmed by the research results. These results suggest that Latino immigrants and American born individuals are more similar than different in terms of happiness at work.

**Index Terms-** latino, immigrants, born-in-the USA participants, happiness at work, acculturation

## I. INTRODUCTION

The pursuit of happiness is such an integral part of the human condition that the founding fathers identified it as an inalienable right. Most of our daily decisions and activities are oriented to the final end of being happy. Gavin and Mason (2004) take Aristotle's concept of happiness "The greatest human good is to live a good life" and propose that this is what we currently known as happiness (p.379). Gavin and Mason (2004) argued that the human being is a complex self that cannot be separated from his or her social environment in the process of achieving happiness. Therefore interpersonal relationships, social activities, and working environments are all key elements of the pursuit of happiness (p.387).

According to Diener, Lucas and Oishi (2002) individuals' happiness and life and life satisfaction are the cognitive and emotional judgment of their own lives. Different elements are part of happiness, such as the lack of negative moods or experiencing a large number of positives emotions (Diener, et al., 2002). Individuals evaluations of their well-being may change depending upon life events (Diener, et al.,2002). However an individual's subjective interpretation of the world

also affect their happiness independent of the circumstances that they are experiencing (Diener, et al., 2002). Demographic factors also seem to influence happiness, although how much these factor will increase happiness depends on individual's particular characteristic such as their specific culture (Diener, et al., 2002).

According to Fisher (2010) happiness at work has multiple components such as the type of task to be performed or short-lasting episodes at the workplace. Other elements are people's goals, personalities or job-fit (2010). Fisher (2010) also argues that people tend to experience happiness when their are meeting higher performance standards at work. Fisher (2012) suggests that promoting happy workers will increase their loyalty towards the employer and the overall quality of the workforce.

Gavin and Mason (2004) state that "over 25 million of the 130.5 million workers in America work 49 or more hours a week" (p.379). They state that in 2002 Americans spent 1,815 hours at work. This data is a clear indication of the large number of hours that the average American spends at work. Therefore, how happy or satisfied an individual is at work should greatly impact the pursuit of one's happiness. The individual's perception of his or her happiness at the workplace then becomes an imperative issue in modern times.

There are several elements that can contribute to the promotion of happiness at the work place. Gavin and Mason (2004) argued that organizations should have certain characteristics in order to obtain a happy and productive employee. The authors related to basic characteristics of the Greek definition of happiness: freedom, knowledge, and, virtue. According to them, an organization that allows the individual to achieve these professional needs will increase the chances of having happy and productive employees (p.388).

Gavin and Mason (2004) also stated that an employee's happiness depends in part on the kind of organization for which a person works. Although, this seems to be a fundamental source of an employee's satisfaction, perhaps there are other elements influencing the perception of happiness at work from a more personal source. Staw and Ross (1985) explain job satisfaction from a dispositional approach. According to Staw and Ross the dispositional approach, "involves the measurement of personal characteristics and the assumption that such measures can aid in explaining individual attitudes and behavior" (p.470). Thus Staw and Ross (1985) propose that an individual's attitudes towards work may be influenced by dispositional factors (p.478).

This perspective leads to the question: to what extent do an individual's characteristics or social factors influence their perception of happiness at work. According to Stay and Ross

(1985), an individual's job attitudes can be evidence of socially learned answers or reactions to different events. This idea opens a window to a wide variety of factors that may influence the individual's attitude towards specific jobs and his or her perception of happiness. If individual characteristics or social factors do in fact influence happiness at work, then diversity in the workplace may be a critical factor as well.

Ethnic diversity characterizes multiple employment sectors in America. Miami is a city with one of the most ethnically varied workplaces in America. According to Resnick (1988) Miami's demographics, social environment, and language have suffered deep transformations since 1959 due to continued waves of immigration from Cuba, and other non-Anglo countries (p.89).

Mohl (2013) suggests that the population of Florida is compounded by North American retirees, black immigrants from the Caribbean, Jewish people, Italians, Cubans, Nicaraguans, and immigrants from other areas of the Caribbean Basin (p.60). Immigration related issues are the frequent use of languages other than English, especially Spanish, as common practice in Miami. According to Resnick (1988), Spanish is commonly used in Miami at the workplace, as an aid for the incoming Hispanic immigrants, in the family context (especially among Cubans, whose children born in the USA are mainly bilingual), and to a certain extent in local governmental and political affairs (p.89). This certainly reflects the powerful impact of Hispanics in Miami. It is logical to believe that other ethnic groups have also influenced the social life of this city.

Since Miami has such high Latin immigration, important factors of the economy of the city are related to companies trading with Latin America, investors and businessmen, and the constant flow of Latin American tourists. As per Resnick (1988), around the year of 1979 the number of multinational corporations that had founded their headquarters in Miami exceeded 80.

As previously stated happiness at work or, work satisfaction, has been approached from a situational and a dispositional perspective. The situational approach relates to task characteristics, wage, and other workplace issues. Gavin and Mason (2004) propose that when the workers are provided with a meaningful workplace they will tend to be more productive and happy (p.381). These authors place an important relationship between the happiness at work and the overall individual's happiness. The idea that an individual cannot be truly happy if he or she is not happy at work was sustained by Gavin and Mason (2004). Gavin and Mason (2004) alert that recently, productivity has taken precedence over workers' happiness and wellbeing (p.390). According to Gavin and Mason, working in fine organizations is essential in order to reach happiness.

On the other hand, Near, Rice and Hunt (1978) propose that individual's job satisfaction will depend on his or her overall life satisfaction (p.261). Weaver (1978) suggests that job satisfaction would not be the main cause of most employees' happiness (p.839).

Staw and Ross (1985) defend the dispositional approach suggesting that individuals' attitudes towards work are learned responses to wide range of previous social experiences (p.471). According to Staw and Ross (1985) the individual may have developed positive or negative attitudes towards work due to other jobs or family experiences (p.471). Staw (1986) points out that although individuals may be concerned about the

characteristics of their job, satisfaction is more closely related to their unique way of interpreting the world (p.44). Therefore, Staw (1986) suggests that an individual who is predisposed to be happy will perceive his or her job situations very differently from an individual who is negatively predisposed (p.44). Staw's (1986) findings suggest that people's attitudes towards work were stable over time, even when people changed employers and occupations (p.44). He proposes that an individual who is unhappy in a workplace is likely to be unhappy in another work environment, even if it is better (p.44).

Staw et al. (1986) stated, "affective disposition is a significant predictor of job satisfaction" (p.69). Here Staw et al. (1986) proposes to define affective disposition as "internal cues" that modify how individuals interpret and act upon their workplace (p.72).

It is also very important for this study to acknowledge the particular characteristics of Miami and its workforce. Nissen and Russo (2006) point out that Miami has a large number of immigrants, who mostly work in the industries of service, tourism, and business with Latin America (p.123). Another important aspect of the city is its varied demographics. It is mentioned by Nissen and Russo (2006) that Miami has attracted immigrants from all Latin America (Central and South America), the Caribbean Isles (Haiti, Cuba, Dominican Republic, Puerto Rico, Jamaica, and the Bahamas); other residents of the city are African Americans, European-Americans and Jews (p.124).

According to Nissen and Russo (2006) the Hispanic population in Miami is exceptional; most of them Cubans, Centro and South Americans differing from the rest of the country where the majority of Hispanics are Mexicans (p.124). Nissen and Russo (2006) state that, in Miami, the majority of occupations are not in the management or professional fields, but they are highly concentrated in the service industry (p.125). Nissen and Russo further note that in general, wages in Miami are lower than in the rest of the United States (p.125).

It is also important to note that in Miami the use of languages other than English is common. According to Resnick (1988) not knowing Spanish is perceived by many as an unjust barrier since bilingual skills are required for many positions (p.91). Resnick (1989) notes that in Miami, unlike the rest of the USA, immigrants have a unique loyalty to their language of origin, which is predominantly seen among the Cuban community (p.100).

Another important factor that needs to be considered is the changes that the immigrant goes through as a result of adapting to the new land. This individual brings with him a language, traditions, values that belong to his homeland. The psychological and cultural transformations that an individual experiences when encountering the new culture is known as acculturation (Sam & Berry, 2010).

According to Sam and Berry (2010) people acculturate and adapt to the new environment in diverse ways. However those who are able to keep their original culture and be a part of the new one, have a better adaptation than those who chose one of the cultures or none of them (Sam & Berry, 2010). The concept of adaptation refers to changes that people experience in the process of meeting environmental requirements (Berry, 1997). One possibility during this adaptive process is that the individual can highly assimilate the environment or integrate it with his



original culture (Berry,1997). In another scenario the immigrant can display segregational and marginal behaviors due to an internal conflict created by the acculturation process (Berry,1997). According to Berry (1997) these behaviors lead to acculturative stress.

Berry (1997) states that immigrants, on a group-level, suffer different transformations while acculturating. These changes can go deeply enough to shift languages, religion, and values (Berry, 1997). According to Berry (1997) different pre-existing factors may affect the acculturation process, variables such as: immigration age, level of education, gender, or how different cultures are can have an impact.

One of many challenges for Latino immigrants is the exposure to a new language. The lack of this skill represents a big obstacle for the immigrant. Learning the new language is part of the acculturation process. According to Ahadi and Puente-Diaz (2011), fluency in both native and host languages is an indicator of acculturation. Bilingualism shows that the individual has been able to integrate elements of their original culture with new one (Ahadi & Puente-Diaz, 2011). Ahadi and Puente-Diaz advised that although monolingualism in the new culture's language is uncommon, it can be used as indicator of acculturation level in immigrant's children. It would be a sign of a high acculturation level and the vanishing of the native culture to a certain extent (Ahdi & Puente-Diaz, 2011).

Another variable that needs to be taken into account is if the individual comes from a culture that is individualistic or collectivistic. This will play a role during the acculturation process. Gomez (2003) indicates that this process impacts the individual's values. Gomez (2003) also suggests that work attributes preferences will be influenced by collectivism and individualism. As per Mollol, Holtom and Lee (2007) individuals from a collectivistic culture, like Hispanics, will feel obligate to help economically to their extended family.

It is likely that individuals born in America would have a different perception of happiness at the workplace than their Latino immigrant coworkers. In a city like Miami, it is important to know if Latino immigrants and natives perceive happiness at the workplace in the same way. This is the main purpose of this study. This study has two hypotheses. The first one, states that there is a significant difference between Latino immigrants and American born individuals in their perception of happiness at work. The second proposes that there is a significant correlation between perception of happiness at the workplace and level of acculturation

## II. METHOD

### Participants

This study had a total of a hundred participants. The sample was divided in two equal groups. The first group was composed of individuals who were born and raised in the United States. The second group was individuals who were born in a country other than the United States, and who immigrated to the United States. All participants were full time employees and 18 years of age or older.

The subgroup of immigrants had a higher number of male individuals (34 participants), while the group of individuals born in the USA the number of male participants was significantly

lower (16 participants). The average age of the immigrant participants was 41 years old, with oldest participant being 67 and the youngest 23. While the average age of individuals born in the USA was 32 years old. The oldest individual in this group was 66 and the youngest 19 years old.

In the immigrant subgroup level of education was well distributed, two participants with no educational degree, 7 respondents with a High School degree, 25 with a College degree and 16 with Graduate diplomas. The majority of the immigrant participants worked in entry level positions (N=25), with 12 respondents were employed as supervisors, 7 as managers, one with an upper management position and one executive director. One immigrant participant did not select any of the given choices, and wrote "team leader" instead. Also, three participants of this group left this item in blank.

The American born group was integrated by one participant with no educational degree, 10 with a High School diploma, 36 with College and 3 with Graduate degrees. In terms of level of employment entry level positions were the most common (N=37), there were few supervisors (N=4), managers (N=5), only one respondent in an upper management position, and 3 executives directors..

The immigrants who participated in this study were from Central, South America and the Caribbean. There were 7 participants from Central America, 13 South Americans, and 30 from the Caribbean. Immigrants from the Caribbean represent the 60% of this group (see Figure 1). The average age at immigrate of this group was 21 years old, with an age range of 61. The earliest age of immigration of this group was one year old and the oldest 62.

The American born participants were 12 White American individuals, 4 African American, 31 Latinos and 4 that selected other as their ethnicity. One participant selected both, Latino and White American as ethnicity. This participant's grandparents had emigrated from South America. Out of these 50 participants, 28 stated that either their parents or grandparents had emigrated from the Caribbean, Central and South America.

## III. INSTRUMENTATION

The researcher created a Likert Scale Questionnaire in order to measure happiness in the workplace and acculturation level. The questionnaire also collected important demographic data. The questionnaire's content was influenced by numerous articles described in the literature review ( e.g. Gavin & Mason, 2004; Staw, 1986; Ross & Staw, 1985; Resnick, 1988). Statements were designed to be simple and clear in order to facilitate understanding for all participants. The instrument was designed to have strong face validity.

The questionnaire was composed of three sections. The first one was oriented to measure the individual's happiness at work. It has ten items, one of which is a reversed scored (item 3) to control biases. Participants were instructed to indicate how strongly they agree or disagree with each statement by selecting a number from 1 to 5 (ranging from 1 "strongly disagree" to 5 "strongly agree"). A maximum score of happiness at work was 50 and a minimum was 10.

The second part of the questionnaire consisted of five items designed to measure acculturation level. This part of the



questionnaire has two reversed scored items (items 3 and 5). This questionnaire has a maximum score for acculturation level of 25 and a minimum score of 5 as a minimum score. Finally, the questionnaire included a demographic section, which is composed of ten items.

#### IV. PROCEDURES

The researcher selected participants via a convenient quota sampling strategy in the community of Miami. The researcher went to commercial plazas, colleagues' workplaces, and a local university. The researcher approached all potential subjects personally, and made note of the number of individuals who refused to participate. This was done for the purpose of calculating the response rate. Only two individuals refused to participate. Therefore the response rate for this survey was 98%. Participants were then given the research questionnaire. Informed consent was obtained prior to participation. The data was collected once the participants have completed the questionnaire. The completed questionnaires were placed in a large manila envelope labeled results. This was done in order to assure the anonymity of the responses. The completed surveys were kept in a locked drawer of the researcher's desk. Only the primary researcher and her supervisor had access to the collected data.

#### V. DATA ANALYSIS

This study presented two hypotheses. The first one stated that there is a significant difference between Latino immigrants and non-immigrants in their perception of happiness at work. A T-Test was implemented by the research to test the first hypothesis. The second hypothesis proposed that there is a significant correlation between perception of happiness at work and level of acculturation. Then, a correlation was the chosen method to test the second hypothesis.

The variables involved in this study are: immigration status (immigrants vs. individuals born in the USA), perception of happiness at workplace, and acculturation level. Immigrant vs. individual born in the USA (immigration status) is considered an independent variable (IV) in this study, since it is supposed to affect an individual's perception of happiness at work. The acculturation level in this study is an IV because it is thought to influence the individual's perception of happiness at the workplace. Perception of happiness at the workplace is considered to be the dependent variable (DV) since it is the measured phenomenon. Other variables presented in this study are age and gender.

#### VI. RESULTS

The immigrant group had a lower happiness at work score ( $M=35.18$ ,  $SD= 5.42$ ) than their American born peers ( $M= 36.44$ ,  $SD= 5.50$ ). The researcher analyzed the data in order to answer the question proposed by the first hypothesis with a t-test. The t-test results did not show a significant difference between these groups ( $P(T\leq t)$  two-tail 0.2512, t Critical two tail 1.9844). The results failed to reject the  $H_0$  (see table 1).

As expected immigrant participants also scored lower on acculturation level ( $M= 17.4$ ,  $SD=2.157$ , max. score =23, min. score=13) compared to American born participants ( $M=19.02$ ,  $SD=2.075$ , max. score 24, min. score=15). For the second hypothesis, the researcher conducted correlations. No significant correlation was found between happiness at work and acculturation for immigrants ( $r=0.25$ ). Likewise there was not a significant correlation between happiness at work and level of acculturation for American born participants ( $r=-0.20$ ) (see table 2).

#### VII. CONCLUSIONS

According to the results obtained it seems like there is not a significant difference between immigrants and American-born individuals in their perception of happiness at work. The results also suggest that there is not a significant correlation between acculturation level and happiness at work for either immigrants or American born employees.

According to these results it is logical to assume that equal incentives or rewards strategies may be used to motivate Latino and American-born employees. Since there is not a significant difference between these groups, same retain strategies to promote employees' loyalty to the organization could be used for both groups. These results also may suggest that Latino and American-born employee experience similar job satisfaction in Miami.

It is important to keep in mind that these results may be unique for Miami due to its demographic characteristics. The results may also suggest that due to the large number of immigrants that have moved to Miami during several generations the environmental demands are not very high for the immigrant individual compared to other cities in the country. As a result of different waves of Latino immigration that Miami has received throughout the years many employees who are born in the USA are Latino immigrant descendants. Taking into account the place that Latinos have in the city's demographics significant part of Miami's workforce are Latino immigrants and Latino immigrant descendants. Based on the on the results of this study these subgroups may not have very different job expectations and satisfaction.

It is important to consider that this study was conducted using a convenient quota sampling strategy, which could have biased the obtained results. Also, the analyzed problem could have been approached using a more elaborated instrument and measurements. There is the possibility that extraneous variables have escaped the researcher's control, influencing results. One variable could be gender (males very significantly dominant in the immigrant group, whereas American born participants were mostly women). It is important to consider that 56% of participants stated that either their parents or grandparents had immigrated from Latin American. This could be a significant bias since these American born participants could be more culturally close to the immigrant participants than other American born participants.

Although, the results did not prove researcher's hypothesis this study aims to encourage future research regarding happiness at work and level of acculturation. There are more answers to be found in this gap in the literature.

#### REFERENCES

- [1] Ahadi, S. A., & Puente-Diaz, R. (2011). Acculturation, personality, and psychological adjustment. *Psychological Reports*, 109(3), 842-862.
- [2] Berry, J. W. (1997). Immigration, acculturation, and adaptation. *Applied Psychology: An International Review*, 46, 5-68
- [3] Diener, E., Oishi, S., & Lucas, R. E. (2002). Subjective well-being: The science of happiness and life satisfaction. In C.R. Snyder & S.J. Lopez (Ed.), *Handbook of Positive Psychology*. Oxford and New York : Oxford University Press.
- [4] Fisher, C. D. (2010). Happiness at work. *International Journal of Management Reviews*, 12, 384-412.
- [5] Gavin, J., & Mason, R. (2004). The virtuous organization: The value of happiness in the workplace. *Organizational Dynamics*, 379-392.
- [6] Gomez, C. (2003). The relationship between acculturation, individualism/collectivism, and job attribute preferences for hispanic mbas. *Journal of Management Studies*.
- [7] Mohl, R. (2013). *Ethnic Transformations in Late-Twentieth-Century in Florida*.
- [8] Mallol, C. M., Holtom, B. C., & Lee, T. W. (2007). Job embeddedness in a culturally diverse environment. *Journal of Business Psychology*.
- [9] Near, J., Rice, R., & Hunt, R. (1978). Work and extra-work correlates of life and job satisfaction. *Academy of Management Journal*, 248-264.
- [10] Nissen, B., & Russo, M. (2006). Building a movement: Revitalizing labor in Miami. *Working USA: The Journal of Labor and Society*, 123-139.
- [11] Resnick, M. (1988). Beyond the ethnic community: Spanish language roles and maintenance in Miami. *Int'l. J. Soc. Lang.*, 89-104.
- [12] Ross, J., & Staw, B. (1985). Stability in the midst of change: A dispositional approach to job attitudes. *Journal of Applied Psychology*, 469-480.
- [13] Sam, D. L., & Berry, J. W. (2010). Acculturation: when individuals and groups of different cultural backgrounds meet. *Perspectives on Psychological Science*, 5(4), 472-481.
- [14] Staw, B. (1986). *Organizational psychology and the pursuit of the happy/productive worker*. The Regents of the University of California.
- [15] Staw, B., Bell, N., & Clausen, J. (1986). The dispositional approach to job attitudes: A lifetime longitudinal test. *Administrative Science Quarterly*, 56-77.

#### AUTHORS

**First Author** – Patricia Iturriaga, B.S, Carlos Albizu University  
**Second Author** – Toni DiDona, Ph.D, Carlos Albizu University

**Table 1**

t-Test: Two-Sample Assuming Unequal Variances

	Happiness at Work Immigrants	Happiness at Work Individuals Born in USA
Mean	35.18	36.44
Variance	29.37510204	30.21061224
Observations	50	50
Hypothesized Mean Difference	0	
df	98	
t Stat	-1.154209042	
P(T<=t) two-tail	0.251221403	
t Critical two-tail	1.984467404	

**Table 2**

Correlation	Happiness at Work Immigrants	Happiness at Work Individuals Born in USA	Acculturation-Immigrants	Acculturation Individuals Born in the USA
Happiness at Work Immigrants	1			
Happiness at Work Individuals Born in USA	-0.040391682	1		
Acculturation-Immigrants	0.248573504	0.105343124	1	

Acculturation  
Individuals Born in the  
USA

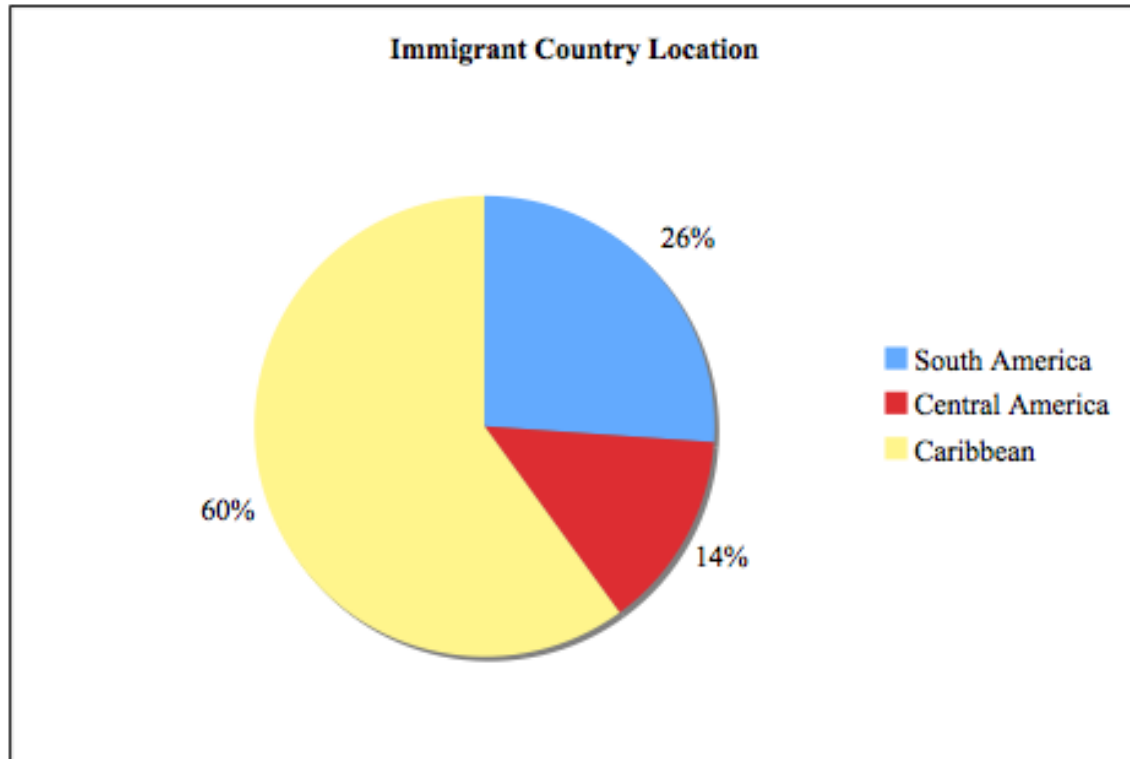
-0.21445472

-0.202986788

-0.293628225

1

Figure 1



# Mycoplasma Pneumoniae infection complicated by multiorgan dysfunction Syndrome (MODS), with a favorable recovery

Dr. Abdul Wahid Bhat<sup>\*</sup>, Dr. Bader Alhomayeed<sup>\*\*</sup>, Dr. Adil Manzoor<sup>\*\*\*</sup>, Dr. Khalid Al-Wadei<sup>\*\*\*\*</sup>, Dr. Ahmed Imtiyaz<sup>\*\*\*\*\*</sup>

<sup>\*</sup> MBBS, MD, MRCP, Consultant department of Nephrology, King Fhad Hospital Medina Munawara (KSA)

<sup>\*\*</sup> MBBS, MD, FCCP, Consultant department of Nephrology, King Fhad Hospital Medina Munawara (KSA)

<sup>\*\*\*</sup> MBBS, MD, FCCP, Consultant department of Nephrology, King Fhad Hospital Medina Munawara (KSA)

<sup>\*\*\*\*</sup> Registrar department of Nephrology, King Fhad Hospital Medina Munawara (KSA)

<sup>\*\*\*\*\*</sup> MBBS, Resident department of Nephrology, King Fhad Hospital Medina Munawara (KSA)

**Abstract-** *Mycoplasma pneumoniae* (MP) is a common pathogen in cases of atypical pneumonia. Most individuals with *Mycoplasma pneumoniae* run a benign course, with non-specific symptoms of malaise, fever and non-productive cough that usually resolve with no long-term sequelae. Multi organ dysfunction is not commonly seen in *Mycoplasma pneumoniae* infection. We, report a case of *Mycoplasma pneumoniae* complicated with multiple organ failure in a previously healthy woman. She had severe hemolysis, acute respiratory distress syndrome and acute renal failure. She had complete recovery with intensive management in an intensive care unit.

## I. INTRODUCTION

**M***ycoplasma pneumoniae* (MP) is the causative agent of community acquired pneumonia in children and adults (1, 2). It has a worldwide prevalence which tends to occur in epidemics. *Mycoplasma* infection commonly affects the respiratory tract and most individuals run a benign course. Symptoms of *Mycoplasma pneumoniae* include fever, malaise, sore throat and a non-productive cough that usually resolve without sequelae. (3) It is well recognized that the vast majority of *Mycoplasma* infections remain undiagnosed. However, MP infection is accompanied by extra pulmonary manifestations in about 20-25% of infected individuals. (4) Several systems can be affected simultaneously but, gastroenteritis, conjunctivitis, uveitis, hepatitis, Steven Johnson syndrome and acute urticaria are uncommon. Severe hemolytic anemia, Adult respiratory distress syndrome and acute kidney injury are rarely seen in patients with *Mycoplasma pneumoniae*. (5) Here, we report a case of *Mycoplasma pneumoniae* pneumonia (MPP) complicated by multiple organ failure with a favorable outcome after intensive treatment. **Key words:-Mycoplasma pneumoniae, Multiorgan dysfunction, ARDS, Acute kidney injury**

## II. CASE REPORT

A 43-year-old Saudi female teacher previously healthy was referred to our hospital with history of cough, blood tinged sputum and breathing difficulty. She was conscious, oriented, ill looking and tachypneic. She had pallor and icterus. Her BP was 130/80 mmHg, heart rate 90/minute and respiratory rate

20/minute. Systemic examination revealed a moderate splenomegaly there was no hepatomegaly. Chest revealed diffuse B/L crepts, no pleural rub or bronchial breathing was heard on auscultation. Her CVS and CNS examination was normal. Investigations revealed Hemoglobin of 5.0gm% ,TLC 10 / mm<sup>3</sup>, platelet 150/mm<sup>3</sup> DLC:- Polymorphs 80%, Lymphocytes 15%, eosinophils, 4%, basophiles 1%, platelets 180/mm<sup>3</sup>, Reticulocyte 8%, Bilirubin 6mg/l, direct 1.5mg/l, indirect 4.5mg/l, ALT 40 u/l, AST 35 u/l, Alkaline phosphatase 145 u/l, LDH 700 u/l, CPK 200 u/l, Calcium 2 mmol/l, Phosphorus 1.2mmol/l, urea 20 mmol/l, creatinine 200 umol/l, CRP 250 u/l, urine examinations revealed albumin+, Rbc's 5-8/hpf, Pus cells 40-50/ hpf, no casts. 24 hr urine protein was less than 1 gm on two occasions. Direct coombs test was positive and coagulogram was normal. Chest x-ray revealed diffuse interstitial infiltrates more on right side( Fig 1) ABG Ph 7.3, Pco<sub>2</sub> 34mmHg, Po<sub>2</sub> 80mmHg, Spo<sub>2</sub> 88% on room air and 96% with 5 litre oxygen through nasal canula. Ultrasonography of abdomen revealed hepato splenomegaly, no lymphadenopathy or ascites. She was put on oral azithromycin 500 mg daily, IV Piperacillin 4.5 gram 6 hourly. Prednisolone 80 mg daily was added in view of possible immune hemolytic anemia. She showed a clinical improvement initially with antibiotic administration however, on day 3rd of her hospital admission her throat was noted to be inflamed. There was further clinical deterioration with worsening CXR changes involving the other lung.(FIG 2) She was more tachypneic with a respiratory rate of up to 30 breaths per minute, tachycardic with a heart rate of 110/minute and remained pyrexial. ABG revealed a fall in PO<sub>2</sub> to 60mmHg, Pco<sub>2</sub> 45mmHg, Spo<sub>2</sub> 88% on nasal musk oxygen. CRP remained elevated at 250 mg/L. She was diagnosed with acute respiratory distress syndrome (ARDS) based on CXR findings which showed bilateral alveolar infiltrates (Fig 2) and PO<sub>2</sub> of 60 mmHg on high flow oxygen. She continued to deteriorate and required invasive ventilation. Additional laboratory work up obtained during patient's hospitalization showed normal anti-dsDNA, ANCA, antinuclear antibody, autoantibody screen, rheumatoid factor, ASO and complement components C3, C4. Tests for hepatitis A, B, and C, and CMV, EBV, and HIV were negative. Bacteriological cultures for sputum and blood were sterile. Cold agglutinins were detected in serum at a dilution of 1/64. Serum for *Mycoplasma* IgM, taken at day 1st of the presentation, was negative however a subsequent sample taken at day 5 of the presentation was positive. These



serological results supported confirming *Mycoplasma pneumonia* as the cause of her acute respiratory distress syndrome, hemolytic anemia and acute kidney injury. She was started with Hemodialysis and ultra filtration via a temporary jugular vein catheter for her progressive increasing urea, creatinine, metabolic acidosis, oliguria and hyperkalemia. She received seven (07) units of group specific pack red cell transfusion. The cross match of blood was also a difficult process due to possible cold agglutinin produced by her infective lesion of chest. She improved over the course of her ten day admission to the Intensive Care Unit. Oral prednisolone 80 mg daily, IV piperacillin was continued. She developed prednisolone induced secondary diabetes mellitus which, was managed with tab gliclazide 80 mg twice a day. On day 14th she started forming more urine. Patient showed signs of improvement. There was neither drop in her hemoglobin nor any rise in bilirubin. Her urea and creatinine were un stable and had mild metabolic acidosis. She was shifted out of intensive care unit and was dialysed regularly 3hr 3 times a week with ultra filtration as required. Follow up chest x-rays showed clearing (Fig 3). Her urine output improved and creatinine got stabilized round at 180 umol/l. She was discharged from hospital with a Hemoglobin of 10.0gm%, creatinine 180 umol/l and bilirubin 2mg/l. Follow up at two months in outpatient clinic revealed normal kidney functions, liver functions and a Hemoglobin of 10gm%. Follow up chest X-ray was normal (Fig4). Hence, she made a complete recovery with an aggressive therapy for 21 days in hospital.

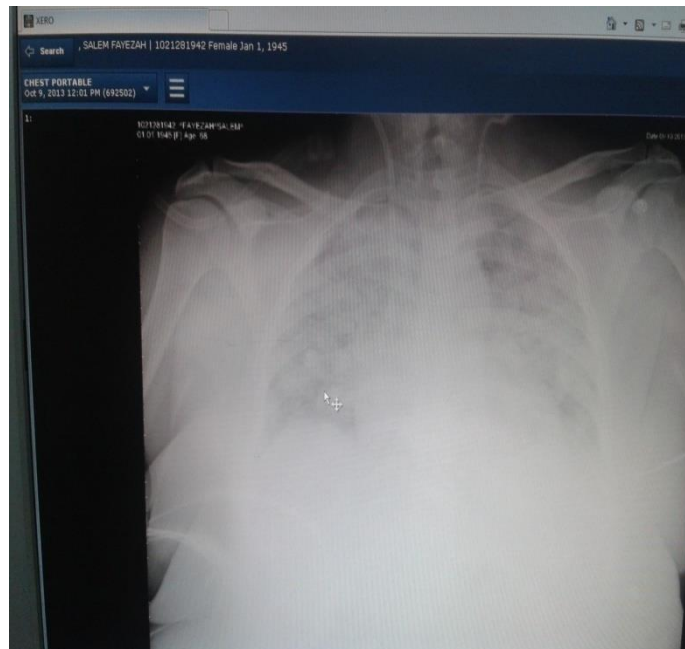
**Table 1. Patient's laboratory results during hospitalization**

Parameter	admission	1 <sup>st</sup> Week	2 <sup>nd</sup> Week	3 <sup>rd</sup> Week
-----------	-----------	----------------------	----------------------	----------------------

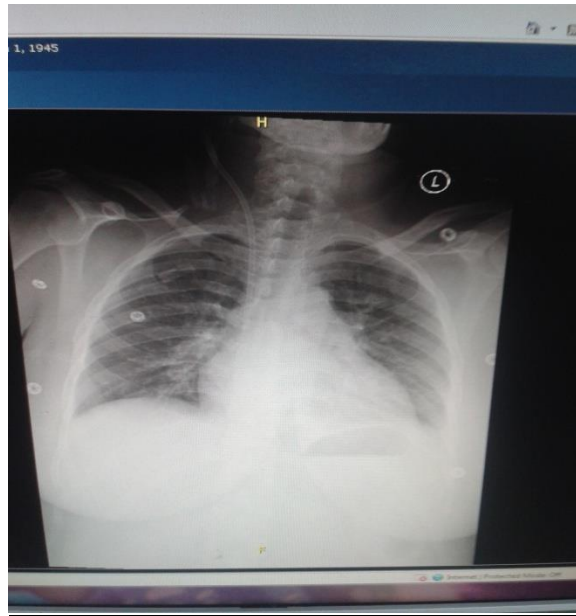
Hb Gm%	5	7	8	10
TLC/mm3	10	11	9	7
MCV	95	98	87	85
Neutrophils /mm3	80	85	76	70
Lymphocytes /mm3	15	13	18	20
Platelet/mm3	180	150	120	110
Reticulocyte %	8	12	6	2
Urea mmol/l	20	55	50	15
Creatinine umol/l	200	700	850	180
Total Bilirubin mg%	6	8	4	2
Direct Bilirubin mg%	1.5	3.5	1.8	0.75
ALT U/L	40	55	45	35
AST U/L	35	45	50	40
LDH U/L	700	500	450	250
CPK U/L	200	400	380	250
Phosphorus mmol/l	3.5	3	2.5	1.8
Calcium mmol/l	1.8	1.5	1.7	2
Anti globulin test	Positive	Positive	Positive	Negative
Cold Agglutinin	Negative	Positive	Positive	Negative
CRP mg/l	250	300	180	80



**Fig:-1 Chest x-ray day of admission showing B/L pneumonia**



**Fig :-2 Chest X-Ray extensive B/L pneumonia and Rt.Jugular vein catheter for dialysis**



**Fig:-3 Chest X-Ray showing clearing of B/L pneumonia and jugular dialysis catheter**

### III. DISCUSSION

The case presented here represents fulminant atypical pneumonia due to *M. pneumoniae* (MP) in a formerly healthy young adult complicated by severe hemolysis, acute respiratory distress syndrome (ARDS) and acute kidney injury (AKI). Atypical pneumonia due to (*M. pneumoniae*, Chlamydia pneumoniae, or Legionella pneumoniae) has been thought to account for 7-20% of community-acquired pneumonia for which a pathogen cannot be identified [6]. Pneumonia develops in 3-10% of patients infected with *M. pneumoniae*. (7) Diagnosis of atypical pneumonia is often difficult since culture or direct detection of the suspected pathogen is time consuming and not readily available. No clinical or radiographic features reliably distinguish *M. pneumoniae* from pneumonia of any other etiology. [8] In most cases, confirmation of diagnosis is based on serologic methods, requiring high acute antibody titers or paired serum samples for definitive diagnosis. Cold agglutinin is a non-specific laboratory investigation which is raised in about 75 percent of cases of Mycoplasma pneumoniae. Serum titer levels of more than 1:64 in a person with a lower respiratory tract infection would highly suggest Mycoplasma pneumoniae infection

Extra pulmonary abnormalities can be an important part of Mycoplasma disease. These manifestations include skin rash, joint involvement, heart disease, central nervous system, renal and hematological involvement (9-10). Unusual and extra pulmonary manifestations of the Mycoplasma pneumoniae (MP) infection with Multiorgan involvement have been reported only infrequently. (11, 12) The exact patho mechanism of the Mp infection-induced multiple organ failure remains unclear. It has been postulated that the cytoadherence of MP, cell invasion, cytotoxicity, immune response, and cytokine production might be involved in its pathogenicity. (12, 13) Although most Mycoplasma pneumoniae infections resolve without complications but, rarely can have a fulminant course and get complicated by Multiorgan dysfunction. Hemolytic anemia is the most common hematologic manifestation, and subclinical

evidence of hemolytic anemia is present in most patients with pneumonia due to *M. pneumoniae* (MP). However, severe hemolysis is extremely rare and is usually associated with severe pulmonary involvement. Antibodies (IgM) to the I antigen on erythrocyte membranes appear during the course of infection and produce a cold agglutinin response in approximately 60 percent of patients, which might result in hemolysis and a positive Coombs reaction through activation of complement factor C3d [14, 15,16] These cold agglutinins develop during the second and third week of illness. Although sometimes hemolysis can be severe, it is usually not clinically significant. Our patients had autoimmune hemolytic anemia (AIHA) caused by cold agglutinins as demonstrated by the direct antiglobulin test. The diagnosis of *Mycoplasma pneumoniae* infection was based on elevated cold agglutinins, and serology in the context of a characteristic illness with adequate response to treatment. Other connective tissue disorders and infective causes were excluded. She had a complicated course and needed invasive ventilation, multiple blood transfusions and Hemodialysis. Despite high prevalence the frequency of fulminant pneumonia due to *M. pneumoniae* complicated by ARDS is reported rarely.(17-24) An important feature in all the studies, including the present one, is that the patients were previously healthy and diagnosed mainly by subsequent serology and outcome of the patients was variable.(17,22,23). Renal involvement in patients with *M. pneumoniae* pneumonia is rare and limited to few case reports and some have needed Hemodialysis [25-33]. Renal manifestations include progressive glomerulonephritis, nephrotic syndrome, transient, massive proteinuria, chronic renal failure due to cold agglutinin, acute interstitial nephritis, acute renal failure due to acute nephritis, haemoglobinuria or hemolytic uremic syndrome, isolated hematuria, cystitis or urethritis. Glomerulonephritis due to *M pneumoniae* could be due to an immunological process and can lead to progressive glomerulonephritis. (31) These have been diagnosed as tubulointerstitial nephritis or proliferative glomerulonephritis. (25-31)

Although we could not demonstrate the pathological changes in the kidneys due, to non availability of a renal biopsy; the renal involvement in our patient seems to be interstitial nephritis. This is evidenced by pyuria with sterile urine, normal complement levels, absence of significant proteinuria and complete recovery of renal function with antibiotics and Hemodialysis support. Most of the reported cases needed Hemodialysis or steroid use to overcome renal failure, but there are reports of renal failure resolved without dialysis or steroid therapy (32). We did use oral steroids upon this patient for her hemolytic anemia that simultaneously took care of her possible interstitial nephritis.

Although, there are reports of some patients with progressive renal failure the prognosis in most of the cases with regard to renal function recovery is probably good.

#### IV. CONCLUSION

Although *Mycoplasma Pneumoniae* infection is usually a benign self-limited disease; this case emphasizes its potential to produce a multiorgan dysfunction. Such complications should be considered and establishing an early diagnosis may have important therapeutic implications. Also, *M. pneumoniae* infections should be included in the differential diagnosis of pathogens presenting with upper respiratory symptoms causing multiorgan dysfunction. Even if only few reports of multi organ dysfunction are reported in infections by *Mycoplasma pneumoniae*.

#### REFERENCES

- [1] Ruskanen O, Nohynek H, Ziegler T, Capeding R. Pneumonia in childhood Etiology and response to antimicrobial therapy. *Eur. J Clin Microbiol Infect Dis* 1992; 11(3): 217-23.
- [2] Sue Y. Community acquired pneumonia in adults. *West J Med* 1994; 161(4): 383-9.
- [3] Blasi F, Tarsia P, Aliberti S, Cosentini R, Allegra L. Chlamydia pneumoniae and *Mycoplasma pneumoniae* Semin Respir. Crit Care Med. 2005; 26(6):617-24.
- [4] Kottayam R, Rozenberg G, Cohn R J. Unusual hematologic manifestations of *Mycoplasma pneumoniae* infection. *J Pediatrics Child Health*. 2007; 43:80-8212.
- [5] Timitilli A, Di Rocco M, Nattero G, Tacchella A, Giacchino R. Unusual manifestations of infections due to *Mycoplasma pneumoniae* in children. *Infec Med*. 2004; 12:113-117.
- [6] Bartlett JG, Mundy LM. Community acquired pneumonia. *N Engl J Med*. 1995; 333:1618-1624.
- [7] Mansel JK, Rosenow EC, 3rd, Smith TF, Martin JW, Jr. *Mycoplasma pneumoniae* pneumonia. *Chest*. 1989; 95:639-646.
- [8] Hsieh SC, Kuo YT, Chern MS, Chen CY, Chan WP, Yu C. *Mycoplasma pneumoniae*: clinical and radiographic features in 39 children. *Pediatric Int*. 2007; 49:363-367.
- [9] Kano Y, Mitsuyama Y, Hirahara K, Shiohara T. *Mycoplasma pneumoniae* infection-induced erythema nodosum, anaphylactoid purpura, and Acute urticaria in 3 people in a single family. *J Am Acad Dermatology*. 2007; 57:S33-35.
- [10] Schulman P, Piemonte TC, Singh B. Acute renal failure, hemolytic anemia, and *Mycoplasma pneumoniae*. *JAMA*. 1980; 244:1823-1824.
- [11] Atkinson TP, Balish MF, Waites KB. Epidemiology, clinical manifestations, Pathogenesis and laboratory detection of *Mycoplasma Pneumoniae* infections. *FEMS Microbiol Rev*. 2008; 32:956-973.
- [12] Waites KB, Tarkington DF. *Mycoplasma pneumoniae* and its role as a human Pathogen. *Clin Microbiol Rev*. 2004; 17:697-728.
- [13] Narita M. Pathogenesis of extra pulmonary manifestations of *Mycoplasma pneumoniae* infection with Special reference to pneumonia. *J Infect Chemotherapy*. 2010; 16:162-169.
- [14] Turtzo DF, Ghatak PK. Acute hemolytic anemia with *Mycoplasma pneumoniae* Pneumonia. *JAMA*. 1976; 236:1140-1141.
- [15] Lindstrom FD, Stahl-Forehead B. Autoimmune hemolytic anemia complicating *Mycoplasma pneumoniae* infection. *Scand J Infect Dis*. 1981; 13:233-235.
- [16] Gehrs BC, Friedberg RC. Autoimmune hemolytic anemia. *Am J Hematology*. 2002; 69:258-271
- [17] Chaudhry R, Tabassum I, Kapoor L, Chhabra A, Sharma N, Broor S. A Fulminant case of acute respiratory distress syndrome associated with *Mycoplasma pneumoniae* infection. *Indian J Pathol Microbiol* 2010;53:555-7
- [18] Tanaka G, Nagatomo Y, Kai Y, Matsuyama M, Kuroki M, Sasaki T, et al. *Mycoplasma pneumoniae* of identical twin sisters with different clinical courses depending on the treatment. *Kansenshogaku Zasshi* 2002;76:1040-4
- [19] Halal F, Brochu P, Delage G, Lammarre A, Rivard G. Severe disseminated lung disease and bronchiectasis probably due to *Mycoplasma pneumoniae*. *Can Med Assoc J* 1977; 117:1055-6.
- [20] Reigner P, Domenighetti G, Feihl F, Bonjour JP, Perret C. Acute respiratory distress syndrome after *Mycoplasma* infection. *Schweiz Med Wochenschr* 1980; 110:220-3.
- [21] Tomioka H, Umeda B, Nakai H. A case of adult respiratory distress syndrome likely due to measles and *Mycoplasma pneumoniae*. *Kansenshogaku Zasshi* 1992; 66:1483-7.
- [22] Lo SC, Wear DJ, Green SL, Jones PG, Legier JF. Adult respiratory distress syndrome with or without systemic disease associated with infections due to *Mycoplasma fermentans*. *Clin. Infect Dis* 1993; 17:S259-63.
- [23] Shah DC, Muthiah MM. Adult respiratory distress syndrome due to *Mycoplasma pneumoniae*. *Postgraduate Med J* 1996; 72:259-63.
- [24] Vitullo BB, O'Regan S, de Chadarevian JP, Kaplan BS: *Mycoplasma Pneumoniae* associated with acute glomerulonephritis. *Nephron*, 1978; 21: 284-288
- [25] Vitullo BB, O'Regan S, de Chandarevian JP, Kaplan BS: *Mycoplasma Pneumoniae* associated with acute glomerulonephritis. *Nephron*, 1978; 21: 284-88
- [26] Pasternack A, Helin H, Vanttinen T et al: Acute tubulointerstitial nephritis in a patient with *Mycoplasma pneumoniae* infection. *Scand J Infect Dis*, 1979; 11: 85-90
- [27] Bonsdorff M, Ponka A, Torproth T: *Mycoplasma pneumoniae* associated with mesangiocapillary glomerulonephritis type II (Dense deposit disease). *Acta Med Scand*, 1984; 216: 427-9
- [28] Andrews PA, Lloyd CM, Webb MC, Sacks SH: Acute interstitial nephritis associated with *Mycoplasma pneumoniae* infection. *Nephrology Dial Transplant*, 1994; 9: 564-566
- [29] Westrhenen R, Weening J, Krediet R: Pneumonia and glomerulonephritis caused by *Mycoplasma pneumoniae*. *Nephrology Dial Transplant*. 1998; 13: 3208-11
- [30] Enomoto N, Nakano Y, Suda T et al: *Mycoplasma pneumoniae* complicated by acute renal failure. *Nihon Kokyuki Gakkai Zasshi*, 2001; 39: 425-9
- [31] Campbell T H, Warwick G, Stevenson R. Rapidly progressive glomerulonephritis and nephrotic syndrome associated With *Mycoplasma pneumoniae* pneumonias. *Nephrology Dial Transplant* 1991; 6(7): 518-20.
- [32] Serkan Oncu1, Avar Ozdemir2, Ayper Somer2, Nuran Salman2, Isik Yalin2, Nilgun, Faruk Okten2 Acute renal failure associated with *Mycoplasma pneumoniae* Infection Case Report *Clin Pract Rev*, 2002; 3(2): 82-85

#### AUTHORS

**First Author** – Dr. Abdul Wahid Bhat MBBS, MD, MRCP, Consultant department of Nephrology, King Fhad Hospital Medina Munawara (KSA), Email: - bhatwahid@yahoo.com Mobile: - 0091-9419526285

**Second Author** – Dr. Bader Alhomayeed MBBS, MD, FCCP,  
Consultant department of Nephrology, King Fhad Hospital  
Medina Munawara (KSA)

**Third Author** – Dr. Adil Manzoor MBBS, FCPS, MRCP,  
Consultant department of Nephrology King Fhad Hospital  
Medina Munawara (KSA)

**Fourth Author** – Dr. Khalid Al-Wadei , Registrar department of  
Nephrology, King Fhad Hospital Medina Munawara (KSA)

**Fifth Author** – Dr. Ahmed Imtiyaz MBBS, Resident  
department of Nephrology, King Fhad Hospital  
Medina Munawara (KSA)



# ARE READY-MADE TECHNOLOGY TRANSFER SOLUTIONS SUITABLE FOR DEVELOPING THE RENEWABLE ENERGY SECTOR IN SRI LANKA?

WITHANAARACHCHI, A.S, NANAYAKKARA, L.D.J.F, PUSHPAKUMARA, C.

Department of Industrial management, University of Kelaniya, Sri Lanka  
[amila.green@gmail.com](mailto:amila.green@gmail.com)

**Abstract-** As per the International Energy Agency, the unprecedented levels of economic growth emerging in the developing nations will make them responsible for future growth in energy demand and greenhouse gas emissions. Based on the International Energy Agency 2009 report, rapidly growing energy demand in developing countries is projected to double by 2030. The development, transfer and use of renewable energy technologies are promising ways towards low-carbon development in these countries. Recognizing the importance of sustainable energy for sustainable development, the origin of transferring sustainable energy technologies in the context of the international climate cooperation and in particular from developed countries to developing countries, lies in the United Nations Framework Convention on Climate Change (UNFCCC).

However, developed nation's homogeneous approaches for all developing countries and their disconnection with developing countries' national enabling factors have resulted with a limited success in promoting them. This paper is a theoretical overview of the current literature, and the paper attempts to answer the research question "Are readymade technology transfer solutions suitable for developing the renewable energy sector in Sri Lanka?" The theoretical overview discusses the current renewable energy sector of the country, followed by theoretical overview of technology transfer process, UNFCCC framework in facilitating the renewable energy technology transfer, and finally the key factors that need to be considered when tailoring the green technology transfer to Sri Lanka

**Index Terms**— CDM, Renewable Energy, Sri Lanka, Technology Transfer, UNFCCC

## Introduction

Among the primary needs of humanity, access to clean and reliable sources of energy undoubtedly plays a prominent role in economic development and human welfare. Although many of the developing nations were being identified as fastest growing economies, most of these countries are still struggling to combat the issues associated with poverty. The region as a whole is experiencing a vibrant economic growth with a high rate of energy consumption fuelled by population growth, economic development, an energy intensive industrial base and urbanization [1]. As per the International Energy Agency, the unprecedented levels of economic growth emerging in the developing nations will make them responsible for future growth in energy demand and greenhouse gas (GHG) emissions [2]. Based on the International Energy Agency 2009 report, rapidly growing energy demand in developing countries is projected to double by 2030 [3].

Catering to the expanding energy services, while tackling the environmental impacts associated with energy use, represents a critical challenge in the 21st century. Recent developments in countries like China and India, where energy production has increased significantly, demonstrate how difficult it is. Carbon emissions from these countries are rising rapidly. Renewable energies have the important potential to provide sustainable solutions in addressing the concerns of both economic developments and environmental challenges. In recent years there has been a significant development of alternative energy technologies, both in terms of performance and cost reduction. Moreover, many developing countries are particularly well positioned when it comes to

developing a new generation of energy technologies [4]. Recognizing the importance of sustainable energy for sustainable development, the United Nations General Assembly has designated the year 2012 as the international year of sustainable energy for all [5]. Therefore, renewable energy is emerging as the energy supply solution for the 21st century.

## Significance of the study

The origin of transferring sustainable energy technologies in the context of the international climate cooperation and in particular from developed countries to developing countries lies in the United Nations Framework Convention on Climate Change (UNFCCC). Literature reveals that the UNFCCC has attempted to promote technology through several means: an Expert Group on Technology Transfers (EGTT), Technology Needs Assessments (TNA), and two financial mechanisms: the Clean Development Mechanism (CDM) and the Global Environment Facility (GEF) [6]. Out of these different mechanisms, Sri Lanka has adopted the CDM and the mechanism for trading “Certified Emissions Reductions” (CER) and “Removal Units” (RMU).

Apart from UNFCCC attempts, many other international frameworks have also supported developing nations with technology cooperation and transfer in the renewable energy sector. However, although many programs are functioning to strengthen the international cooperation, such programs have failed to attain the expected goals for a rapid global clean energy transformation [3]. Many developing countries are affected by lack of resources, particularly for commercial energies in general and electricity in particular, which occur due primarily to wrong policies and investment decisions and limited access to finances. Therefore, any model dealing with the energy sector of developing countries should be able to capture the relevant features effectively to attain the expected results [7]. On the other hand, developed nations’ homogeneous approach for all developing countries and their disconnection with developing countries’ national enabling factors were the main reasons behind the limited success of the current attempts [2]. This is further supported by a recent release by UNFCCC where they have specifically emphasized the importance of tailoring activities to meet unique

circumstances and needs of the developing countries [3].

This paper is a theoretical overview of the current literature, and the paper attempts to answer the research question “Are ready-made technology transfer solutions suitable for developing the renewable energy sector in Sri Lanka?” Apart from the introduction and the significance of the study, the paper is structured along six sections. Thus, the 3rd section of this article presents an overview of the current renewable energy sector of the country. While the 4th section discusses the theoretical overview of the TT process, proceeding sections (section 5 and 6) elaborate the UNFCCC framework in facilitating the renewable energy TT and their failure in doing so. Section 7 of this article highlights the key factors that need to be considered when tailoring the green TT to Sri Lanka. Finally, the last section is the conclusion which highlights the importance of local knowledge in making technology choices for the country.

## Sri Lankan Power sector

After the end of the three-decade civil conflict, the Sri Lankan economy has seen robust annual growth at 6.4% over the course of 2003 to 2012, well above its regional peers [8]. In parallel to the robust economic growth, Sri Lanka has been struggling to meet the rising demand for power. The current statistics show that the country’s electricity demand has been growing at an average rate of 5.9% per annum [9]. Experts claim that with the current escalating demand, the demand for electricity will be doubled by 2020 compared with the 2010 figure. More specifically, in 2010 the base load of the country was 9,268 GWh, and the CEB long-term generation expansion plan forecasts the demand to reach 16,937GWh by 2020 [10].

In 1995 Sri Lanka produced 95% of its grid electrical energy needs from conventional hydro power plants. However, expansion of household electricity consumption and the boost in the industrial sector of the country have forced the country to depend on alternative energy resources such as fossil fuels. The total amount of electricity generated during 2012 was 11,878.8 GWh out of which 70.9% was from thermal power plants (both oil and coal), while 23.0% was from major hydro and the balance 6.2% was from Non-Conventional

Renewable Energy (NCRE) which comprised small hydro, wind power, biomass and solar [11].

A combination of factors has contributed to the emphasis in recent times on generating electricity through NCRE sources. The growing electricity demand, requirement for several resources or an energy mix, environment concerns, and electrification of rural areas which requires high capital investment, operational costs and the difficulties associated with extending grid connected electricity lines to remote areas are the main reasons behind the government motive in promoting NCRE developments. On the other hand, the attractive tariff imposed on the NCRE power sector attracted a large number of local and foreign investments in the NCRE sector [12]. The present contribution of NCRE in grid electricity generation is only 6.2% from the total generation. Based on the SLSEA, Energy Balance 2012, the following table (Table I) exhibits the installed capacities and generation of NCRE power plants by end 2012.

These statistics show that the small hydro is the dominant NCRE power source, followed by wind, biomass and lastly, solar. Small hydro took the lead in the NCRE power sector due to several reasons. Technologies required to harness hydro resource potential are well developed and are available from many sources, including local manufactures. Secondly, the relatively low capital requirement and attractive tariff structure are the main driving forces for the sector’s development [13]. Globally, harnessing wind energy for electricity generation has been one of the fastest growing technologies for the last decade or so and has become well developed and mature [14]. An attractive tariff structure along with the booming market for wind power plant manufacturers were the reasons for the wind power sector’s success in Sri Lanka.

Biomass accounts for over 10% of global primary energy supply and is the world’s fourth largest source of energy [15]. The bioenergy sector is relatively complex because there are many forms of biomass resources. In the Sri Lankan context, fuel wood and agricultural residues are the most common form of biomass available for electricity generation. In recent times biomass has attracted interest as a primary energy source for electricity generation due to its potential as a low cost, indigenous supply and attractive tariff system. However, inconsistencies in the supply chain

mechanism have led biomass to fall behind other NCRE sources. Solar power is a highly abundant energy resource in the Sri Lankan context. However, apart from a few off-grid solar systems and net metering solutions, the country’s total grid connected solar powered capacity is only 1.4MW. Technical limitations in the national grid and high initial investments are the main hindrances for the sector’s development [10].

TABLE I: INSTALLED CAPACITIES AND GENERATION OF NCRE POWER PLANTS BY END 2012 [11]

Type of Power Station	Number of Plants	Total Installed Capacity (MW)	Generation in 2012 (GWh)	Share in Generation (%)
Small Hydro	106	227.3	564.7	77.0
Wind	9	73.0	144.5	19.7
Biomass	2	10.5	22.2	3.0
Solar	4	1.4	2.0	0.3
<b>Total</b>	<b>121</b>	<b>312.2</b>	<b>733.3</b>	<b>100.0</b>

## Theoretical Framework

In literature the term ‘technology transfer’ has been defined and measured in many different ways and assessed against a wide range of criteria. Khalil has defined technology transfer as the process that permits the flow of technology from source to the receiver [16]. Despite the different definitions given for transfer of technology, the development and transfer of technologies in the renewable energy sector are incorporated as priorities in both the UNFCCC and its Kyoto Protocol [17]. Though there are quite a few studies that have been conducted on green technologies between developed and developing countries, to date there are no overcharging theories which have emerged as to how TT models can be used between the two parties to transfer said renewable energies effectively [18].

The literature on TT models revealed that some of the early work of Hayami and Ruttan (1971) and Mansfield (1975) provide some of the earliest perceptions on the modes of TT which are applicable even today. Mansfield classified TT into vertical and horizontal TT [19]. The transfer of technology from one country to the next represents horizontal transfer, which may also involve a degree of vertical transfer as well. This is mainly due to the

fact that low carbon technologies are currently pre-commercial or supported technologies and undergo development towards commercialization within the new country context [18]. According to Bell, technology is transferred through three types of flows of transferable technology between technology suppliers and technology importers (recipients) as Capital goods and equipment, Skills and know-how for operating and maintaining equipment, and Knowledge and expertise for generating and managing technological change [20]. Ivarsson and Alvstam agreeing with Mansfield have shown that TT can be either internalized or externalized [18].

In some literature the transfer of technology and the technology cooperation were used interchangeably to represent diffusion of technology from source to the receiver. But there is a clear difference between the two terms. While in the year 2000 IPCC defined TT as a broad set of processes covering flows of equipment, know-how and experience between various types of actors, technology collaboration can be defined as a mutual agreement between two countries to attain a common goal [20]. International Technology Collaborations which comprise science and technology development, exchange and diffusion through public-private partnership for technology absorption, capacity building and innovative project financing mechanisms are desirable and mutually beneficial to developed and developing countries [21]. A large number of organizations are implementing clean energy technology cooperation programmes among countries to accelerate technology innovation and deployment and reduce global greenhouse gas emissions. This includes numerous bilateral programmes along with such multilateral initiatives and agencies as the Asia Pacific Partnership on Clean Development and Climate, the Major Economies Forum, the Global Environment Facility and Multilateral Development Agencies, the Clean Development Mechanism, the Climate Technology Initiative, the International Energy Agency, the International Partnership for Energy Efficiency Cooperation, and the newly created International Renewable Energy Agency [3].

The Cleaner Development Mechanism (CDM) which was initiated on 3rd September 2002 under the 'Kyoto Protocol' of UNFCCC is defined as an innovative policy tool development which allows emission-reduction (or emission removal) projects

in developing countries to earn certified emission reduction (CER) credits, each equivalent to one tone of CO<sub>2</sub> [22]. The recent publications of UNFCCC have revealed that over a third of the registered and proposed CDM projects claim TT benefits, including both knowledge and equipment transfer from sponsor to host countries [17].

## **Transfer of technology in UNFCCC framework**

The origin of transferring sustainable energy technologies in the context of the international climate co-operation lies in Article 4.5 of the UNFCCC. Article 4 states that developed country parties and other developed parties included in Annex II to take "all practicable steps to promote, facilitate and finance, as appropriate, the transfer of, or access to, environmentally sound technologies and know-how to other Parties, particularly developing country Parties", and to "support the development and enhancement of endogenous capacities and technologies of developing country Parties", and calls on other parties and organizations to assist in facilitating the transfer of such technologies [23].

Accordingly (as mentioned earlier), CDM is one such vehicle (specifically for developing countries like Sri Lanka) to facilitate transfer of technologies between developed and developing countries. Recent studies conducted on CDM tended to concentrate on determining to what extent CDM projects involve transfer. One set of studies analyses transfer claims made in the project design documents (PDD) of CDM projects. A common feature of these studies is that they define TT narrowly [20]. They often do this by implicitly assuming technology as objects that can be moved around. Transfer was considered as simple as the sale or purchase of industrial equipment. This "one shot" relocation of a fully blown technology from one country to another ultimately creates and maintains dependency on the part of the recipient. If transfer is to lead to a more satisfactory outcome, and one which is more in line with the ends of sustainable and equitable development, a much wider approach is required [24].

Although the term 'technology' is commonly used to refer mostly to tangible goods, it is used in academic literature to include intangible elements of



organizations' activities as applied knowledge or know-how [25]. This indicates that in broad view the 'ambition' is not only to use technology, but to master and change technology. Bell (2009) and Ockwell et al., (2009) argue that such capabilities are necessary in developing countries for effective reduction of greenhouse gas emissions that will be associated with economic growth over the coming decades [26].

Certain scholars claim that the narrow view of transfer of technology in PDDs can be attributed to the drivers of the Kyoto Protocol. For example, Lema and Lema (2013) argue that though the Kyoto Protocol facilitates transfer of technology between developed and developing countries, TT is not a formal obligation in CDM [26]. However, irrespective of such arguments, we cannot undermine the UNFCCC's accountability in implementing transfer of technology in a broader sense. For example, the Agenda 21 had already identified the most critical dimensions of TT in Chapter 34: "Environmentally sound technologies are not just individual technologies, but a total system which includes know-how, procedures, goods and services, and equipment as well as organizational and managerial procedures. This implies that when discussing transfer of technologies, the human resources development and local capacity-building aspects of technology choices, including gender-relevant aspects, should also be addressed. Environmentally sound technologies should be compatible with nationally determined socio-economic, cultural and environmental priorities" [21].

## **UNFCCC failure in transferring green technologies**

However, so far the success of the UNFCCC process in promoting green TT has been limited due to several reasons. Firstly, the project-based nature of CDM does not foster large-scale deployment of mitigation technologies or the promotion of innovation in host countries. Secondly, many of the emission reductions achieved by the CDM are not 'additional', which implies that they would have happened anyway and should not be financially supported. Thirdly, several studies of TT in BRICS CDM projects show that income from carbon credits was rarely the primary reason why the

projects were developed, because of the uncertainty of carbon income and the long CDM registration time lags. Finally, CDM projects were concentrated in the largest emerging economies, while African countries and other developing countries have been largely left out [6].

In a different study Pueyo et al., (2012) identify three main gaps of the UNFCCC approach to climate change TT: missing links between international institutions and the national enabling environments that encourage private investment; its non-differentiated approach per (developing) country and technology characteristics; and the unavailability of clear measurements of the volume and effectiveness of TT [27]. As stated, measuring TT is inherently difficult because technology has no measurable physical presence or a well-defined price. Rather, it is embodied in products, intermediate inputs and processes [28]. Thus, among the stated gaps the unavailability of efficient mechanisms for monitoring, reporting and verifying the magnitude and effectiveness of climate change TT in developing countries still remains an unresolved issue in the UNFCCC approach [27].

## **Tailor-made approach for Sri Lanka**

To a large extent, the state of the environment today is the result of the technological choices of yesterday. The adverse consequences of rising fossil fuel prices and environment concerns that we face today are the results of past actions that authorities have taken over the last few decades. Similarly, the state of the environment in the future will be determined largely by the technologies we choose today. Literature reveals that the present non-differentiated approach adopted by the country needs to be changed if we are to secure energy sources which are affordable, convenient and sustainable. Thus, the following section of this article attempts to highlight the key factors that need to be considered when tailoring the renewable energy technologies to a Sri Lankan context.

### *Large and stable demand*

The TT can be broadly divided into two categories: inter-firm mechanisms and intra-firm mechanisms [26]. Licensing, technical agreements and cooperation, joint ventures, turnkey projects, and



the purchase of capital goods such as machines and equipment are the main mechanisms that fall under the inter-firm approaches, while Foreign Direct Investments (FDI) falls under the intra-firm mechanisms [29]. Apart from this market oriented approach, non-market oriented approaches such as cross-border movement of personnel, meetings, workshops, conferences and other public forums, and open literature (journals, magazines, books and articles) also play a prominent role in transferring technologies to developing countries [22]. Empirical studies about the international climate change mitigation TT have identified trade and FDI as the main mechanisms via which technologies diffuse internationally [2].

Out of these mechanisms the most common TT approach that was used in the Sri Lankan renewable energy sector is the direct purchase of plants and equipment. Considering the fact that Sri Lanka's large and small reserves of hydro power have already been utilized, the authorities have given prominent priority towards wind and solar power sectors. In the current context investors are directly purchasing the components from foreign suppliers and the local value addition remains very low. Further investigations reveal that the concern on large and stable demand was the primary reason for the country to depend on international trade. The private sector, owner of most green technologies and responsible for most TT, is attracted by the scene of a large and stable demand. The success of China, India and Brazil in attracting and deploying foreign technologies and growing domestic renewable energy industries seems to confirm this point. A large market allows technology businesses to build a significant production scale and achieve lower production costs as a result of economies of scale and technological learning curves [30].

#### *Capacity to absorb the transferred technology*

Countries with significant technological capabilities (such as China & India) would have the ability to absorb the most innovative technologies and develop an endogenous technological base. On the other hand, countries with low capabilities (such as Sri Lanka) would target more mature technologies and would have a stronger dependence on foreign equipment [6]. In the Sri Lankan context, except for small hydro, almost all modern renewable energy technologies are sophisticated and new to the country and technical expertise and facilities for design, manufacture, operation and maintenance are

still lacking. Presently there are very few local manufacturers and agents who are involved in renewable energy projects, and the existing maintenance networks are not adequate at all. This lack of expertise and facilities is a major technical barrier for the development of the Sri Lankan renewable energy sector [31].

The literature indicates that to achieve sustainable development, developing countries require assistance with developing human capacity (knowledge, techniques and management skills), developing appropriate institutions and networks, and with acquiring and adapting specific hardware. Thus, TT from developed to developing countries must therefore operate on a broad front covering these "software" and "hardware" challenges [24].

#### *Dependence on foreign sources*

In their early critiques of TT, the developing countries focused primarily on reducing what they considered to be the excessive costs of technology transactions and the many restrictive clauses imposed on recipients by the suppliers. Increasingly, focus has shifted from the costs and characteristics of imported technologies to include the factors affecting the creation and maintenance of technological capabilities in the developing countries. However, in most cases, current practices of TT do not allow the recipient enterprises to accumulate such technological capabilities [32].

Globally grid connected solar PV is the fastest growing energy technology with an average annual growth rate of 60% during the five year period from 2005 to 2010 [15]. In parallel to such developments, many international organizations initiated off-grid solar home systems in rural parts of Sri Lanka. However, due to the fast expansion of the national grid, standalone solar home systems in rural villages are going out of use. Yet, the use of solar energy as a supplementary source of electricity generation in commercial buildings and industrial facilities is gaining momentum with the introduction of the net metering facility. In the present context all the hardware pertaining to net-metering solutions are imported from either Europe or from East-Asian countries. Though the Sri Lankan engineers have the skills to do the regular maintenance, very little has been done to absorb the technical skills to produce commercially viable solar cells in the home country.

The local counterparts who engaged in developing pilot scale solar cells are not able to produce to the required specifications and standards of quality, reliability, durability, and cost. Raw materials, parts, and components have to be imported continuously to maintain the proper functioning of the imported technology. These required imports can become a drain on scarce foreign currency [29].

#### *Inappropriate supply chain mechanisms*

The assimilation and linking the initially acquired technology into the wider structure of the economy through forward and backward linkages to other areas of production is a key concern specifically in the biomass sector of Sri Lanka. In Sri Lanka, biomass, mainly fuel wood, still provides nearly 50% of the primary energy, which is predominantly catered for a wide variety of thermal energy applications in domestic and commercial sectors. At the most sophisticated end of the end use spectrum lies the steam generation and gasification applications, presently used in many major industries. Steam generated in boilers is used to produce electricity, completing a full cycle of elevating a primary form of energy to a very refined and versatile energy form which is electricity.

Sri Lankan engineers claim that the technology behind biomass power plants is not that complex and they claim that the country already has the capacity to manufacture certain components. But the real issue lies with the supply chain mechanisms behind the sector. Biomass requires a lot of preliminary steps to be followed (growing, harvesting, chopping, drying and feeding) in order to get it going and generate electricity. In the Sri Lankan context the lack of consistent supply chain mechanisms that support continuous generation of electricity via biomass is the major concern. Thus, if we are to develop the biomass-based electricity generation sector of the country, TT should penetrate the backward and forward integrations behind the core technology acquired.

#### *Need for technology adoption*

Pertaining to the above issue, one of the key factors which the current TT in the renewable energy sector faces is the challenges in adopting the imported technology. The adaptation is necessary because of physical or climatic factors. Adaptation in some cases may require relatively sophisticated inputs of skills or information, drawing on the

experience of other local firms. It has been found in various empirical studies in Latin America, Africa, and newly industrializing countries that the primary source of technological change within firms has arisen not from formal R&D activities but from an accretion of these relatively minor troubleshooting efforts to adapt equipment and procedures to local conditions [32].

Classic examples could be found in the current wind power developments sector of the country. Globally, wind energy for electricity generation has been one of the fastest growing technologies for the last decade or so and has become well developed and mature [14]. Similarly, the Sri Lankan government has also given a prominent priority to the wind power sector of the country and large scale developments are taking place in the North western, southern, and central part of the country. However, presently all the components in the wind power turbines are imported to the country from India, Europe, and from China. Most of these technologies were developed adhering to the environmental conditions of the transferor's country. Thus, already the local investors claim that some of such imported components face technical issues (such as plant factor and unexpected breakdowns) due to the salt level of the sea breeze (specifically in the north western part of Sri Lanka).

#### *North-to-South vs. South-to-South technology transfer*

The breadth of the adoption which is required in a transferred technology also depends on the source and the receiver of the technology. The IPCC framework usually applies to renewable energy technologies transferred from North-to-South. But as Brewer (2007) points out, it neglects the fact that some developing countries have climate-friendly technologies which could be transferred from South to North and also from South to South [24]. Today, developing countries in Asia, South America and Africa are among the world leaders in the production of a wide range of climate-friendly technologies [25]. Again, specific examples could be found in the world wind power CDM projects. Literature reveals that out of the top six suppliers to wind power CDM projects, two are Chinese and one is Indian. The other three are developed country global market leaders [26]. This picture shows a relatively strong representation of developing countries in current green TT.

## conclusion

The ready-made TT solutions that are widely available in the Sri Lankan renewable energy sector have proven their long-term un-sustainability. The concept of TT goes beyond mere transmission of equipment or even embodied knowledge. Effective TT also involves the transfer of tactical knowledge capabilities that cannot be subjected to market-like exchange. Thus, there is a clear difference between technology trade and broad transfer of technology.

Unless Sri Lanka has the proper knowledge to make informed choices among technological options, there is a risk that the efforts to promote international TT may become overwhelmingly supplier driven and geared more towards transferring available technologies rather than technologies required by the country.

## References

- [1] P. Wijesuriya, Energy for year 2000, University of Sri Jayawardenapura.
- [2] A. Pueyo, and P. Linares, Renewable Technology Transfer to Developing Countries: One Size Does Not Fit All, IDS Working Papers, 2012(412), 1-39..
- [3] R. Benioff, H. de Coninck, S. Dhar, U.E. Hansen, J. McLaren, and J.P. Painuly, Strengthening Clean Energy Technology Cooperation under the UNFCCC: Steps toward Implementation, NREL, ECN and URC, 2010.
- [4] KAS 138
- [5] United Nations (2011) '2012 International Year of Sustainable Energy For All', [Online], Available: <http://www.un.org/en/events/sustainableenergyforall> [27 March 2014].
- [6] Pueyo, A., and Garcia, R., Mendiluce, M., and Morales, D. (2011) 'The role of technology transfer for the development of a local wind component industry in Chile', Energy Policy, vol. 39, no. 7, pp. 4274-4283.
- [7] Subhes C. Bhattacharyya and Govinda R. Timilsina, (2010). 'A review of energy system models', International Journal of Energy Sector Management, Vol. 4, no. 4, pp. 494 – 518.
- [8] World Bank (2014) <http://www.worldbank.org/en/country/srilanka/overview>.
- [9] Ceylon Electricity Board (CEB), (2011) 'Long Term Generation Expansion Plan', Colombo.
- [10] Ceylon Electricity Board (CEB), (2013), 'Long Term Generation Expansion Plan 2013 - 2032', Colombo.
- [11] SLSEA, (2013) 'Sri Lanka Energy Balance', Sri Lanka Sustainable Energy Authority, Colombo.
- [12] Deheragoda C.K.M. (2009) 'Renewable energy development in Sri Lanka', [http://www.techmonitor.net/tm/images/e/ee/09nov\\_dec\\_sf6.pdf](http://www.techmonitor.net/tm/images/e/ee/09nov_dec_sf6.pdf).
- [13] SLSEA, (2012) 'Sri Lanka Energy Balance', Sri Lanka Sustainable Energy Authority, Colombo.
- [14] REN21 (2012), Renewables 2012 Global Status Report, Paris: Renewable Energy Policy Network for 21st Century, REN21 Secretariat.
- [15] REN21 (2013), Renewables 2013 Global Status Report, Paris: Renewable Energy Policy Network for 21st Century, REN21 Secretariat.
- [16] Khalil, T. (2009) 'Management of Technology', India: Tata McGraw-Hill.
- [17] UNFCCC. (2010) The Contribution of the Clean Development Mechanism under the Kyoto Protocol to Technology Transfer.
- [18] Watson, J., MacKerron, G., Ockwell, D. and Wang, T. (2007) 'Technology and carbon mitigation in developing countries: Are cleaner coal technologies a viable option?'
- [19] Ramanathan, K. (2008) An Overview of Technology Transfer and Technology Transfer Models, [Online], Available: [http://www.business-asia.net/Pdf\\_Pages/Guidebook%20on%20Technology%20Transfer%20Mechanisms/An%20overview%20of%20TT%20and%20TT%20Models.pdf](http://www.business-asia.net/Pdf_Pages/Guidebook%20on%20Technology%20Transfer%20Mechanisms/An%20overview%20of%20TT%20and%20TT%20Models.pdf) [9 Jan 2013].
- [20] Lema, R. and Lema, A. (2012) 'Technology transfer? The rise of China and India in green technology sectors', Innovation and Development, Vol. 2, no. 1, pp.23 – 44.
- [21] Philibert, C. (2004) 'International energy technology collaboration and climate change mitigation', France: Organisation for Economic Co-operation and Development.
- [22] Karakosta, C., Doukas, H. and Psarras, J. (2009) 'Shaping sustainable development strategies in Chile through CDM', International Journal of Climate Change Strategies and Management, Vol. 1, no. 4, pp. 382 – 399.
- [23] United Nations, Division for Sustainable Development. Agenda 21: The Report of the United Nations Conference on Environment and Development, Chapter 34: Transfer of environmentally sound technology, cooperation & capacity- building. Rio de Janeiro: Earth Summit, UN; 1992.
- [24] Karakosta, C., Doukas, H. and Psarras, J. (2010) 'Technology transfer through climate change: Setting a sustainable energy pattern', Renewable and Sustainable Energy Reviews, Vol. 14, no. 6, pp. 1546 - 1557.
- [25] Brewer, T.L. (2010) 'Technology transfer through climate change: Setting a sustainable energy pattern', Renewable and Sustainable Energy Reviews, Vol. 14, no. 6, pp. 1546 - 1557.
- [26] Lema, A. and Lema, R. (2013) 'Technology transfer in the clean development mechanism: Insights from wind power', Global Environmental Change, Vol. 23, no. 1, pp. 301 – 313.
- [27] Pueyo, A., Mendiluce, M., Naranjo, M.S., and Lumbreras, J. (2012) 'How to increase technology transfers to developing countries: A synthesis of the evidence', Climate Policy, Vol. 12, no. 3, pp. 320 - 340.
- [28] IPCC, (2000) 'Methodological and technological issues in technology transfer', Special Report of Working Group III of the Intergovernmental Panel on Climate Change, Geneva, IPCC.
- [29] Wei, L. (1995) 'International technology transfer and development of technological capabilities: a theoretical framework', Technology in Society, Vol. 17, no. 1, pp. 103 – 120.
- [30] Stern, N.H., 2007. The Economics of Climate Change: The Stern Review. Cambridge University Press.
- [31] Senanayake, G. (2009) 'Renewable Energy Report', Asian and Pacific Centre for Transfer of Technology of the United Nations – Economic and Social Commission for Asia and the Pacific (ESCAP).
- [32] Kathuria, V. (2002) 'Technology transfer for GHG reduction: A framework with application to India', Technological Forecasting and Social Change, Vol. 69, no. 4, pp. 405-430.

# REVIEW ON MINIMIZING DISTORTION AND IMPROVING QUALITY OF VIDEO IN MULTI CLIENTS NETWORK

MISS. AMREEN M. KHAN, PROF. RANJANA S. SHENDE

Department of Computer Science and Engineering,  
G. H. Rasoni Institute of Engineering and Technology for Women  
Nagpur, India

Department of Computer Science and Engineering,  
G. H. Rasoni Institute of Engineering and Technology for Women  
Nagpur, India

**Abstract-** In this paper, the video streaming is proposed for multiple clients network. The scalable video is delivered from server to multiple clients over different access networks, aimed to reduce the distortion of received videos. The video present in database of server. The video characteristic is captured in this paper. Integer programming is proposed for the deterministic packet scheduling. It is very computationally complex for solving. So, the heuristic algorithm is used for deterministic packet scheduling and convex approximation problem is used for randomized packet scheduling. The proposed convex programming algorithm is used for the better performance and comparative studies for : 1) the rate control algorithm about higher video quality; 2) reduces average delivery delay by 70% of existing system; 3) results in higher average video quality more than the two developed heuristics types; 4) runs efficiently, up to three times faster than the best-performing heuristic; and 5) does indeed provide service differentiation among users.

**Index Terms-** *scalable video, streaming, multiple clients, video quality, streaming rates.*

## Introduction

The video streaming that is presented in this paper has been developed for a multiclients network in order to increase the number of clients using service of a server at a time and the comfort of users and to monitor their well performance. For this purpose several algorithm and approximation like heuristic algorithm and convex approximation are installed within a server have been using WLAN network respectively.

The heuristic algorithm, convex approximation and convex programming algorithm has been implemented within a potential application refers for multiple clients: 1) multiradio wireless device connected to Medical, Industries and Scientific (ISM) bands; 2) multiradio clients working with spectrum bonding; 3) multiradio clients fixed with a

connection of licensed bands (like 3G) and ISM bands (like IEEE 802.11 networks) with satisfactory evaluation.

As a result, this technique has been developed based on the least-squares parameter estimation in MATLAB, which are provided with video searching capabilities. The firmware of these service has been implemented using the optimization problem and randomized packet scheduling defined in the convex approximation problem.

In parallel, rate control algorithm and their respective have been used in order to control these service from a Linux based PC.

Video streaming is main goal in multiclients network from a server to multiple clients for achieving the video with minimize distortion.

The main target was to minimize distortion and wellbeing to address the huge indirect costs of streaming in building. Reports by H.264/SVC and Abing estimates the video streams coding and network characteristics respectively at about 8% of normal coders and network capturing. Before the services the video quality was very low and time was also taking more for one streaming.

So, the main goal of project was to address these costs by minimizing the distortion of video in muticlients network.

To achieve the previously mentioned general goal, the project designed a services of video streaming in cooperation with a capturing network characteristic service. This multiclients network consists of the server already available in network augmented with new clients.

The server manages and coordinates in network and establishes a connection with the external



clients signalling for enriched information exchange. In this way it will be possible to improve video quality and thus reduce the costs and time of streaming activity.

By adding external communication to the infrastructure envisioned by the project it will also become possible to use the same infrastructure to support applications like video streamer. This project had partners from both industry and medical to form a well balanced consortium that has experience in providing service contractors while possessing technical expertise in the relevant technical fields. The consortium used this experience and knowledge to raise video quality to the next level.

The streaming helps us to get our desired video in our laptops or any device, so, we can see it anytime. The server is responsible to get the videos in clients. As the videos are stored into database of server. In this paper, clients request the server. The server response by streaming the video.

## RELATED WORK

Nikolaos M. Freris, Cheng-Hsin Hsu, Jatinder Pal Singh, and Xiaoqing Zhu [1] integer problem is used to scheduling the randomized packets. Each packet is randomized i.e soft decision. The uplifting technique is used for randomized packet scheduling. This technique is used to determine streaming rates and packet loss probability over a network. While it is decreasing the decision variable for sending frame and quality layer over a network. By this it can replace the equality constraints in difference of truncation distortion of the frame and packet loss probability over a network with inequality constraints in truncation distortion greater than or less than packet loss. This gives an equivalent formulation with no nonlinear equality constraints. The above properties guarantee that an optimal integer solution for user satisfies the property that frame is sent over a network, if all frames have high video quality, are sent over a network as well. The problem can be converted in convex program by using only exponential transformation and not in geometric transformation. By using convex approximation obtain a value for transmission probabilities (decision probability for sending a frame over a network). The feature of this method contains the user frame having multiple packet. The convex programming formulates approximation

multilinear functions. Hybrid convex approximation is used for balance between performance and computational complexity. It is observed that Hybrid convex approximation more improves the technique of decision probability for sending frames.

For deterministic packet scheduling the heuristic algorithm is used. There are three types of algorithm simple rate distortion optimization, progressive rate distortion optimization and hybrid algorithm. Based on simple rate distortion algorithm C. Hsu, N. Freris, J. Singh, and X. Zhu [2], takes packet loss rate as input. It ignores drifting distortion and it first sorts the frames. It then sequentially schedule the access networks until it fully loaded i.e right before their loss probability exceed a value. Then it sorts potential quality improvement. The simple rate distortion algorithm assumes drifting distortion which less accurate for videos. Whereas progressive rate distortion algorithm it follows the video dependency structure and iteratively sends more frames by selecting the frame that would reduce total distortion the most. The algorithm stops if all frames have negative net distortion impact values, or if there is no unsent frame. By observing a dependency structure, we can largely reduce the number of net distortion to be computed. More precisely, algorithm considers the decodable frames at each steps, that is to say the frame with all their ancestors transmitted earlier. A Hybrid Rate-Distortion Optimization algorithm, which uses Simple rate distortion algorithm to bootstrap a solution, and then applies Progressive rate distortion algorithm to send more frames. Hybrid rate distortion algorithm stops when there is no immediate frame leading to distortion reduction.

Multiple frame allocation is a word used for bit allocation for blocks of frames. The main objective for this to minimize distortion of the block frames. The bit allocation problem is solved at a block level as it produce a better quality than solves at frame level. This happens because of the flexibility of bits among same block frames. The bit problem can be solve by the solver which is used for the problem, it is not accurate for bit allocation so Mohamad Hefeeda and Cheng-Hsin Hsu [3] developed a technique called mOPT i.e optimal algorithm based on simplex method. They collect the transform coefficients, number of bits, and size of each bit for enhancement layer. This data is used for parameter of rate distortion model.



Path diversity was later considered by J. Chakareski, and B. Girod [5]. They presented an error cost function with sender driven transmission with packet diversity. There are network paths to which server is sending data units to clients and server needs to transmit the data packets on the forward channel. The server does not transmit packets after ACK is received from backward channel. The server checks the acknowledge comes from and it stops the data at that time, this time is called final time which also present final state. Server is sending packets it is initial time and initial state. Only non-final states are take to action.

Based on error cost optimization P. Chou, and Z. Miao [4] developed the scenario of sender driven streaming. It is observed that if the path leads ACK then there is probability of data packet lost or late is zero and if path leads no ACK then the probability that is data packet is lost or late given that no ACK is received. The data units transmitted in distorted rate. The encoded data is packetized into dataunits and dataunits are stored in media server in files, in streaming media system. First, server selects this units for transmission. Second, data units are sent over a network with packets, if packet is lost, packet again sent to network. Each packet contains one and only one data unit so one to many packets are sent over networks. For packet transmission, algorithm are used and for encoding also algorithm are used.

Multilink support and quality-adaptive streaming reduce the video interruptions and achieves a higher and more stable average quality over multiple network. To achieve multilink establishing connection to network is important, by binding communication socket. But client machine should configured properly, packet should be routed to correct interface and machine must aware of defaults packet reach it, are the requirement. The segments are form and each segments of data are sent properly so it is divided into parts. First part compromise with more request can sent to the server and server can handle enough request. Otherwise the clients are waiting for responses and server does not handle more requests so it make a challenge for communication properly. For that the scheduler response that request come first and one by one so scheduler can easily schedule request and it become easy for server to response. The second part compromise with size of segments if size become too small then it can be send before next data request come from client to server. So the performance of the server become low by the

network interface. Therefore, the segments partially kept constant throughout transmission by the method introduced of Kristian Evensen, Tomas Kupka, Dominik Kaspar, Pal Halvorsen, Carsten Griwodz [8]. The size of segments is large enough and proper for scheduler, can take advantage in HTTP pipeline. Multilink support [8], which can greatly facilitate the multiple clients for video streaming.

Fulvio Babich, Marco D'Orlando and Francesca Vatta [9] techniques is introduced for the minimize the distortion in packet transmission. It provide scenario of peak signal to noise ratio which video metric can be used for improving the video quality at end user. The objective is to collect distortion information involved with each data packet. This technique to provide the less distorted packet over the network. During encoding, the encoder selects the loss causing packet and generate hint for aware with loss causing packets. It is then easy to defining scheduling scheme; give more priority to packet with higher loss impact and providing the resources to packet with lower loss impact. The usage of hint, it is used in MPEG-4, syntactic means for storing scheduling information of packet of streaming server. The priority scheme is used for minimize error propagation over the packets.

## I. PROPOSED WORK

In the Fig 1, there is a network established using WLAN networks. The clients are three and they connect with the server. The client 1 request to server for video simultaneously client 2 and client 3 also request to server at a time. The server response to client 1, client 2, and client 3. The server when provide video to all clients, the streaming rate, video quality, runtime, and packet delay of video. The video is 10-s video clips repeated throughout simulation. The packet size is 1000 B. For one client, the proposed algorithm and rate control algorithm is run for comparing. The hybrid algorithm is run for three user for 300 times for best performances.

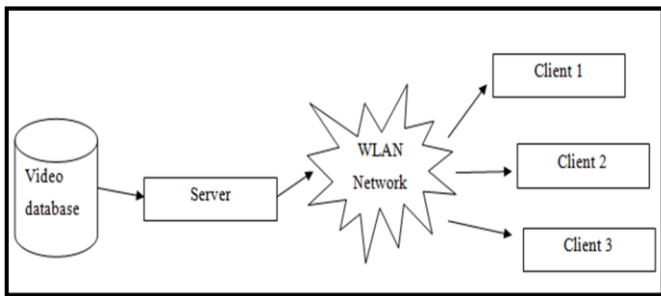


Fig 1: Simulation for multiple user scenarios

## II. CONCLUSION

We develop a Video Streaming Software System. It contains server and multiple clients connected by Wi-Fi modem. The clients get the requested video through streaming process by server. The videos are stored into database of server and clients enjoy the videos of their desired as the videos are stored into the files of storage. Multiple clients have no problem of streaming as video streaming proceed one by one to all the clients. The performance will be detect of five multi-user scalable video streaming strategies in a simulated wireless network scenario which suffers from limited capacity and packet loss. For analysis derive the expression for delay and play deadlines.

## REFERENCES

- [1] Nikolaos M. Freris, Cheng-Hsin Hsu, Jatinder Pal Singh, and Xiaoqing Zhu, "Distortion-Aware Scalable Video Streaming to Multinetwork Clients", *IEEE/ACM TRANSACTIONS ON NETWORKING*, VOL. 21, NO. 2, APRIL 2013.
- [2] C. Hsu, N. Freris, J. Singh, and X. Zhu, "Rate control and stream adaptation for scalable video streaming over multiple access networks," in *Proc. IEEE PV*, Hong Kong, Dec. 2010, pp. 33–40.
- [3] M. Hefeeda and C. Hsu, "Rate-distortion optimized streaming of fine-grained scalable video sequences," *Trans. Multimedia Comput. Commun.s, Appl.*, vol. 4, no. 1, pp. 2:1–2:28, Jan. 2008.
- [4] Philip A. Chou, *Fellow, IEEE*, and Zhouong Miao, "Rate-Distortion Optimized Streaming of Packetized Media", *IEEE Transaction on Multimedia*, VOL. 8, NO. 2, APRIL 2006.
- [5] J. Chakareski and B. Girod, "Rate-distortion optimized packet scheduling and routing for media streaming with path diversity," in *Proc. DCC*, Snowbird, UT, Mar. 2003, pp. 203–212.
- [6] L. Jiang and J. Walrand, "A distributed CSMA algorithm for throughput and utility maximization in wireless networks," *IEEE/ACM Trans. Newts.*, vol. 18, no. 3, pp. 960–972, Jun. 2010.

- [7] Dimitri P. Bertsekas, "Convex Optimization Theory," Massachusetts Institute of Technology, Athena Scientific, 2009.
- [8] J Kristian Evensen, Tomas Kupka, Dominik Kaspar, Pal Halvorsen, and Carsten Griwodz, "Quality-Adaptive Scheduling for Live Streaming over Multiple Access Networks," in *Proc. ACM NOSSDAV*, Amsterdam, The Netherlands, Jun. 2010.
- [9] Fulvio Babich, Marco D'Orlando and Francesca Vatta, "Video Distortion Estimation and Content-Aware QoS Strategies for Video Streaming over Wireless Networks", Copyright 2010, IGI Global

## AUTHORS

**First Author** – Amreen Khan, ME II<sup>ed</sup> year, Department of Computer Science and Engineering, G. H. Raison Institute of Engineering and Technology for Women Nagpur, India, [khanamreen67@gmail.com](mailto:khanamreen67@gmail.com)

**Second Author** – Ranjana Shende, PHD pursuing, Department of Computer Science and Engineering, G. H. Raison Institute of Engineering and Technology for Women Nagpur, India, [Ranjana.shende@gmail.com](mailto:Ranjana.shende@gmail.com)

# Comparative efficiency of five potash and phosphate solubilizing bacteria and their key enzymes useful for enhancing and improvement of soil fertility

Sajidmohammad A Saiyad\*, Dr. Yogeshvari K Jhala\*\*, Dr. R. V. Vyas\*\*

\* Shri P.M. Patel institute of P.G. studies & research in science, India

\*\* Department of agricultural microbiology, Anand agricultural university, India

**Abstract-** Series of experiments were carried out to investigate K mobilization and their abilities of native KMB & P solubilization and their abilities of native PMB. Total five isolates showed their prominent efficiency of K mobilization & P mobilization. Among five isolates two best cultures were PBA16 *Bacillus coagulans* & M29 *Bacillus megaterium* for PSB and almost all five in same range for KMB. P solubilizing index was carried out in Sperber & Aleksandrov agar media supplemented with ROCK phosphate and Tri- calcium phosphate (TCP). PBA16 gave 4.60 solubilizing index and maximum P release 36.69 at  $\mu\text{g/ml}$  in 6 DAI supplemented with TCP and 68.80  $\mu\text{g/ml}$  in 6 DAI supplemented with Rock phosphate. All KMB isolates exhibited acid production in media with tolerate wide range of pH concentration In mass production, all five cultures showed well growth in Sperber, Aleksandrov & Phytate media after 5 to 6 day after incubation. Their colonies were round or irregular, white and their shape was rod and motile. They were capable of dissolving both phosphate and potassium and PBA16 & M29 strains had high phosphate and potassium dissolution capacity effectively. All five cultures for KMB & PSB strains were characterized through morphological, physiological characteristics and their enzymatic activity.

## I. INTRODUCTION

In the last century, when the chemical fertilizers were first introduced into the agriculture, most of the problems faced by farmers to increase crop yield were solved. However, chemical fertilizer slowly started to show their side effect in agro ecosystem and environment ultimately harming human and other animals. In view of that use of biofertilizers and organic matters were recommended to apply in integrated manner for improvement of plant nutrient supply and thereby sustainable crop production (Han *et al.*, 2006). Basically, biofertilizers are living microorganisms that colonize the rhizosphere or the zone that surrounds the roots of plants (Shen, 1997). These microorganisms have ability to convert nutritionally important macro elements such as nitrogen, phosphorus and potassium (NPK) from unavailable to available form through biological processes (Ahmed, 2009). This group of bacteria are also broadly termed as 'plant growth promoting rhizobacteria' (PGPR) [6] and among them key genera are *Pseudomonas*, *Azospirillum*, *Burkholderia*, *Bacillus*, *Enterobacter*, *Rhizobium*, *Erwinia*, *Serratia*, *Alcaligenes*, *Arthrobacter*, *Acinetobacter* and *Flavobacterium*. etc. (Rodriguez, Fraga, 1999).

Most of the essential plant nutrients, including phosphorus and potash, are naturally found as insoluble forms in soil. A large portion of the inorganic phosphate applied to soil as fertilizer is rapidly immobilized after application and becomes unavailable to plants. Thus, the release of insoluble and fixed forms of phosphorus and natural potash of soil are important aspect of increasing soil macro nutrient availability. Microorganisms such as phosphate solubilizers and potash mobilizer can play a vital role in release of available forms of phosphorus and potash from insoluble forms present in natural pool.

## II. PHOSPHATE SOLUBILIZING MICROORGANISMS

A large portion of inorganic phosphate applied to soil as chemical fertilizer is rapidly immobilized and becomes unavailable to plants. Thus, the release of insoluble and fixed forms of phosphorus is an important aspect of increasing soil phosphorus availability. Microorganisms have an important role in the phosphorus conversion processes in the soil. Phosphorus found in the chemical structure of microorganisms as phosphates and plays a significant part in the energy metabolism like in the phosphorylation reaction of high energy compounds formation etc. in respiratory and fermentative processes in addition; also it has a plastic function, as involved in the synthesis of nucleoproteins and lipids. The prime mechanism of mineral phosphate solubilization by microorganism is the production of organic acids and acid phosphatases which mineralize and mobilize phosphorus in soil. It is generally accepted that the major mechanism of mineral phosphate solubilization is the action of organic acids synthesized by soil microorganisms resulting in acidification of its surroundings. Both gram + ve and - ve organisms like *Pseudomonas*, *Bacillus*, *Burkholderia* etc. are among the most powerful phosphate solubilizers (Mehta and Nautiyal, 2001; Singh *et al.*, 2011). Since 1956, based on their phosphorus nutrition, the microorganisms have been classified in five groups based on characteristics. Bacteria assimilating to the same extent of mineral and organic phosphorus; bacteria assimilating particularly mineral phosphorus; bacteria assimilating particularly organic phosphorus; bacteria solubilizing tricalcium phosphorus in the form of glycerophosphate; bacteria solubilizing tricalcium phosphorus.

Phosphorus is used differently by the various microorganisms due to their participation in the processes of the solubilisation and fixation of phosphates in the soil mineralization. There is evidence that the chemical nature of

most of the organic phosphorus in the soil is of microbial origin. Most of the microorganisms possess an enzymatic system which enables them to mineralize phosphorus containing organic compounds, and the phosphatase activity of the microorganisms has been known for a long time. Up to 50% of the microorganism isolated from the soil and rhizosphere exhibit phytase activity. Atlas (1998) considers that bacteria have both phytase and nuclease and a result of it able to mineralize not only glycerophosphate but also lecithin. In 1964, Mazkin and Kuznetova divided soil microorganisms according to their enzymatic mechanism in five groups as follows: microorganisms with low phosphatase activity (e.g. mycobacteria, micrococci, bacillus mycoides); microorganisms with high phosphatase activity (e.g. pseudomonadaceae family representatives); microorganisms with high phosphatase and ribonuclease activities (e.g. *Bacillus megaterium*, which possesses a glucose induced adaptive ribonuclease) and microorganisms with high phosphatase, ribonuclease and deoxyribonuclease activities (e.g. *B. subtilis*, *B. cereus*).

### III. POTASH MOBILIZING MICROORGANISMS

Plants absorb potassium from the soil and its availability in soil is dependent upon the K dynamics as well as on total K content. Out of the three forms of potassium found in the soil, soil minerals make up more than 90 to 98 per cent of soil potassium [2]. The second non-exchangeable form of potassium up to 10 per cent of soil potassium is predominantly the interlayer K of non-expanded form as elite and lattice in K-feldspars [3, 4]. Release of non-exchangeable K to the third exchangeable form occurs when level of exchangeable and solution K is decreased by crop removal, runoff, erosion and/or leaching [2, 5] (*Priyanka Parmar et al.*, 2013).

Many microorganisms in the soil are able to solubilize 'unavailable' forms of K-bearing minerals, such as micas, illite and orthoclases by excreting organic acids which either directly dissolve rock K or chelate silicon ions to bring the K into solution (Groudev, 1987; Friedrich *et al.*, 1991; Ullman *et al.*, 1996; Bennett *et al.*, 1998). Therefore, the application of K solubilizing microorganisms (KSM) (*Zahra et al.*, 1984; Vandevivere *et al.*, 1994; Barker *et al.*, 1998) is a promising approach for increasing K availability in soil. Production of carboxylic acids like citric, tartaric and oxalic acids is also associated with feldspar solubilization by microorganisms (*Malinovskaya et al.*, 1990; Sheng and Huang, 2002b Sheng, 2005).

Plant growth-promoting bacteria (PGPR) have been reported to be the key elements for plant establishment under nutrient-imbalance conditions. Their use in agriculture can favour the reduction of agro-chemical use and support eco-friendly crop production (*Herrera et al.*, 1993; Glick, 1995; Requena *et al.*, 1997). PGPR can also improve plant growth, plant nutrition uptake root growth pattern, plant competitiveness and responses to external stresses. Different PGPR including associative bacteria such as *Azospirillum*, *Bacillus*, *Pseudomonas*, *Enterobacter* have been used for their beneficial effects on plant growth (*Klopper and Beauchamp*, 1992; *Hoflich et al.*, 1994 Sheng, 2005).

### IV. MATERIALS AND METHODS

The present investigation was undertaken with the aim of comparative efficacy of five potash and phosphate solubilizing bacteria and their key enzymes useful for enhancing and improvement of soil fertility to exploit their.

The detailed information about materials used and methods adopted for the present research work has been elaborated in this chapter. The study was conducted at Department of Agricultural Microbiology, B.A. College of Agriculture, Anand Agricultural University, Anand, during Feb 2014 to April 2014.

#### **Qualitative estimation of phosphate and potash solubilizing efficiency of test cultures on agar plates.**

All the isolates were spot inoculated on Sperber's medium supplemented with tri calcium phosphate and Aleksandrova's media containing mica for testing mineral phosphate and potash substrate solubilisation respectively. Plates were incubated at  $30 \pm 2^\circ\text{C}$  for five days with observation on colony diameter every 24 h. Clear zone formation around the growing colony indicated phosphate solubilization activity. Solubilization Index (SI) was calculated according to method described by Collavino *et al.* (2010) using following formula. Experiment was also carried out for checking culture's efficiency by replacing Calcium phytate in place of TCP.

#### **Qualitative estimation of phosphate solubilization efficiency in liquid medium.**

Erlenmeyer flasks (250 ml) containing 100 ml of the sterilized liquid Sperber's medium were inoculated with 100  $\mu\text{l}$  of bacterial suspension (approx.  $10^8$  cfu/ml). For each isolate three flasks were inoculated. The flasks were incubated on rotary shaker (150 rpm) at  $30 \pm 2^\circ\text{C}$ . After 3, 5, 7 and 10 days, measurement of pH using pH meter and liberated P in broth following Vanado-molybdate method was carried out (*Jha et al.*, 2009). The graph of OD versus concentration of phosphate in  $\mu\text{g}$  was plotted for the standard and samples were compared to calculate P concentration.

#### **Qualitative estimation of potash solubilizing efficiency in liquid medium**

Hundred (100) ml of sterilized Aleksandrov media containing mica as mineral potash source. 250 ml Erlenmeyer flask were inoculated with 100  $\mu\text{l}$  of bacterial suspension (approx.  $10^8$  cfu/ml) and incubated at  $30 \pm 2^\circ\text{C}$  for 10 days. For each isolate three flasks were inoculated. The flasks were incubated on rotary shaker (150 rpm) at  $30 \pm 2^\circ\text{C}$ . After 3, 5, 7 and 10 days, each flask was checked for potassium release by flame photometry. The suspension was centrifuged at 10,000 rpm for 10 min and supernatant was retained. 1ml of supernatant was taken in 50 ml volumetric flask and volume was made to 50 ml with distilled water and mixed thoroughly. After that the solution was fed to flame photometer for estimating K (*Hu et al.*, 2006). released from the mineral mica individually by test bacteria.

#### **Qualitative estimation of phosphatase enzyme activity**

##### **Estimation of acid phosphatase activity**

Incubated 3 ml of substrate (para nitrophenol) at  $37^\circ\text{C}$  for 5 min. Added 0.5 ml of enzyme extract and mix well. Remove



immediately 0.5 ml from this mixture and mix it with 9.5 ml 0.085N NaOH. This corresponds to zero time assays (Blank). Incubated the remaining solution with Substrate enzyme for 15 min at 37°C. Drawn 0.5 ml of sample and mixed it with 9.5 ml NaOH solution. Measured absorbance of blank and incubated tubes at 405 nm on spectrophotometer. Taken 0.2 to 1.0 ml (4 to 20 mH) of standard, dilute to 10.0 ml with NaOH solution. Read the colour following standard curve was prepared to find out unit activity.

#### Estimation of alkaline phosphatase activity

Incubated 3 ml of substrate (para nitrophenol) at 37°C for 5 min. added 0.5 ml of enzyme extract and mixed well. Removed immediately 0.5 ml from this mixture and mixed it with 9.5 ml 0.085N NaOH. This corresponds to zero time assay (Blank). Incubated the remaining solution with substrate enzyme for 15 min at 37°C. Drawn 0.5 ml of sample and mix it with 9.5 ml NaOH solution. Measured absorbance of blank and incubated tubes at 405 nm on spectrophotometer. Take 0.2 to 1.0 ml (4 to 20 mH) of standard, diluted to 10.0 ml with NaOH solution. Read the colour following standard curve was prepared to find out unit activity.

#### Determination of phytase enzyme activity

For primary screening, 100µl suspension of these flasks was plated onto a phytase screening turbid agar media plates (PSM) containing 1.5% glucose, 0.1% Na- phytate (Hi media, India), 0.2% NH<sub>4</sub>NO<sub>3</sub>, 0.05% KCl, 0.05% MgSO<sub>4</sub>.7H<sub>2</sub>O, 0.03% MnSO<sub>4</sub>, 0.03% FeSO<sub>4</sub>.7H<sub>2</sub>O and 2.0% agar (pH 7.5) and incubated at 50°C for 2-5 days. Bacterial isolates, capable of hydrolyzing Na-phytate which were recognized by their surrounding clear halo, were further selected and repeatedly streaked on nutrient agar plates. Hydrolytic zone was calculated by subtracting the diameter of zone of growth from diameter of total halo area.

#### Quantitative analysis of phytase producing microorganisms by spectrometry

Each of the bacterial isolates were grown in 50ml of liquid medium containing 0.1 % sodium phytate, 1% peptone, 0.2% (NH<sub>4</sub>)<sub>2</sub>SO<sub>4</sub>, 0.05% KCl, 0.05% MgSO<sub>4</sub>.7H<sub>2</sub>O, 0.03% MnSO<sub>4</sub>, 0.03% FeSO<sub>4</sub>.7H<sub>2</sub>O, pH 7.5 in a 250ml flask and incubated at 50°C for three days on a rotary shaker at 200rpm. Crude enzyme was harvested by centrifugation at 10,000g for 10mins at 4°C and the clear supernatant was used as the source of extracellular phytases.

Sodium phytate was used as substrate for assaying the activity of phytase. Phytase activity was determined by measuring the amount of liberated inorganic phosphate. The reaction mixture consisted of sodium phytate (Sigma; 0.5% w/v) prepared in sodium acetate buffer (0.2 M, pH 5.5) and 0.2ml of supernatant. After incubation at 50°C for 30mins, the reaction was stopped by adding an equal volume of 15% Trichloroacetic acid. The liberated phosphate ions were quantified by mixing 100µl of assay mixture with 900µl of 1.0 M H<sub>2</sub>SO<sub>4</sub> 10% ascorbic acid- 2.5% ammonium molybdate (3:1:0.1) (v/v). After 20mins of incubation at 50°C, absorbance was measured at 700 nm.

## V. RESULT AND DISCUSSION

Screening and selection of efficient microorganisms having beneficial characters to optimize higher crop yield and to conserve the sustainability of the agricultural ecosystem is an important approach in Agricultural Microbiology. The present investigation was aimed to have comparative efficacy of five phosphate and potash solubilizing native bacteria and their key enzymes useful for enhancing soil fertility *in vitro*.

#### Qualitative estimation of phosphate solubilization efficiency of test cultures

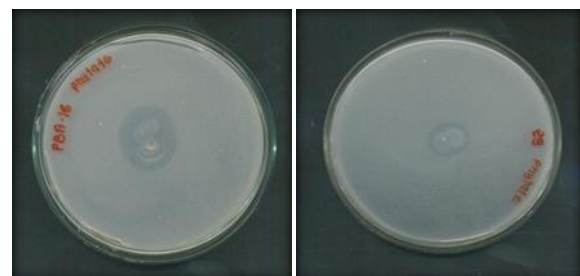
Phosphate solubilization efficiency of test cultures was tested on Sperber's media supplemented with 'P' substrates like Tri Calcium phosphate (TCP) and Calcium phytate.

#### Tri calcium Phosphate solubilization by selected strains



Total 5 native microbial strains were screened for P solubilization activity on Sperber's agar media supplemented with TCP as source of phosphorous. The solubilization zone formation was observed at 5 days. The SI for different isolates was ranging from 1.0 to 4.60 and 1.0 to 3.65 in Sperber's medium. The highest SI was recorded for *B. coagulans* II (4.60) followed by *E. asburiae*, *B. coagulans* I, *Bu. metallica* and *B. megaterium* as 1.0, 4.41, 1.00 and 2.13 respectively. While the lowest SI was recorded to be 1.0 for isolate *Bu. metallica* and *E. asburiae*.

#### Solubilization of Ca-phytate by native strains



The ability of the isolates to solubilize insoluble organic phosphate in form of Ca-Phytate was also tested in media containing Ca- Phytate as sole source of phosphate. After 5 days of incubation the zone diameter were recorded and SI was worked out. The highest SI 3.13 was recorded for isolate *B. coagulans* II followed by isolate *E. asburiae*, *B. coagulans* I, *Bu. metallica* and *B. megaterium*. Standard check *B. coagulans* I was recorded with SI 3.13. SI for all the isolates was found statistically different from each other.



### Qualitative estimation of potash (K) solubilization efficiency of test cultures



Potash solubilization efficiency of five cultures was tested on Aleksandrov's media containing mica as source of mineral potash. The highest SI in Aleksandrov's medium was recorded for isolate *B. coagulans* I (3.55) followed by *B. megaterium*, *E. asburiae*, *B. coagulans* II and *Bu. metallica*.

### Quantitative estimation of mineral phosphate and potash solubilisation by selected test cultures

#### Estimation of phosphate by VM method

Phosphate solubilization assay in liquid medium was performed with two insoluble P substrates, TCP and rock phosphate in MS broth. Observations were recorded at 3, 5, 7 and 10 days after inoculation and release of P was estimated by vanado-molybdate method. Prior to media preparation the substrates were thoroughly washed with sterile double distilled water to remove free P residues.

#### Total P release from TCP in Sperber's broth

All of 5 strains showed significantly higher solubilization of phosphate than control and in Sperber broth with tri calcium phosphate, strain *E. asburiae* and *B. megaterium* had P-solubilizing ability up to 51.78 µg/ml and 53.41 µg/ml after 6 day of incubation respectively and *B. coagulans* I had 77.47 µg/ml after 8 days of incubation respectively.

All the five strains showed decrease in pH of the medium as then soluble P content increases this shows that the organisms release phosphorous as a result of organic acid production in the medium.

#### Total P release from rock phosphate in Sperber's broth

P solubilizing bacteria plays an important role in plant nutrition through the increase in P uptake by the plants. Applications of phosphate solubilizing microorganisms have been used as P-biofertilizer for crop cultivation and reported increased soil fertility. In present study the strain effective in P-solubilization are *B. coagulans* II and *B. megaterium* which are found is have good potential to be applied biofertilizer to increase 'P' in soil and assimilation of phosphate which will be useful to increase crop yield. In Sperber broth with rock phosphate, *B. coagulans* II & *B. megaterium* were found as most efficient strains and P-solubilizing ability up to 68.80 µg/ml and 103.57 µg/ml after 6 days of incubation respectively. pH values were measured at 2 to 8 days of incubation and the results showed that pH value were always higher than 6.5.

### Quantitative estimation of mineral potash solubilisation by test cultures

#### Testing of potash mobilizing capacity of bacteria in liquid assay by flame photometry

After observing the positive solubilization index of potential KMB isolates on Aleksandrov agar plates supplemented with mica, the isolates were further analyzed in Aleksandrov liquid media for K release with broth from minerals feldspar and mica from 2 DAI to 8 DAI. In Aleksandrov media supplemented with feldspar isolate *E. asburiae* gave highest K release 4.85 µg ml<sup>-1</sup> at 6 DAI, which was declined to 4.50 µg ml<sup>-1</sup> at 8 DAI and considered as best K solubilizer, next was *Bu. metallica* which showed 4.78 µg ml<sup>-1</sup> of K release at 8 DAI. Least K release was exhibited by *B. coagulans* I which gave 3.07 µg ml<sup>-1</sup> at 8 DAI and *B. coagulans* II exhibited 3.51 µg ml<sup>-1</sup> at 8 DAI, K release in broth.

### Qualitative and quantitative analysis of organic acids production in liquid media by HPLC

HPLC analysis of culture filtrate was carried out to identify and quantify the organic acids produced during solubilization of TCP by selected two cultures *Bu. metallica* and *B. megaterium* at 5 DAI. During TCP solubilization, it was found that the major organic acids produced by both the bacteria are lactic and gluconic acids.

Total organic acid production was recorded as 35,708.78 µg/ml and 5122.3 µg/ml of *Bu. metallica* and *B. megaterium* respectively, which was lowest among all the isolates which can be correlated with its P solubilization efficiency of this culture. Overall results showed that lactic acid is the major organic acid produced by both the isolates followed by gluconic acid. Among the five native cultures, it was observed that two cultures *Bu. metallica* and *B. megaterium* were found overall best for 'P' solubilizers and their organic acid profiling was carried out using HPLC.

Sr. No.	Organic acid	Concentration (µg/ml) after 5 DAI	
		<i>Bu. metallica</i>	<i>B. megaterium</i>
1	Oxalic acid	-	0.0
2	Gluconic acid	35205.03	1772.2
3	Tartaric acid	-	0.0
4	Pyruvic acid	-	0.0
5	Malic acid	-	0.0
6	Malonic acid	-	0.0
7	Lactic acid	80.80	3185.8
8	Acetic acid	106.66	0.0
9	Citric acid	43.87	0.0
10	2-Keto Gluconic acid	153.94	38.6
11	Propionic acid	118.47	125.7
12	Butyric acid	-	0.0
13	Succinic acid	-	0.0
<b>Total Organic acids</b>		<b>35708.78</b>	<b>5122.3</b>

### Quantitative estimation of mineral phosphatase and phytase enzymes of selected cultures

### Determination of acid phosphatase activity by phosphorous solubilizing bacteria

Extracellular acid phosphatase was eluted on rock phosphate and TCP, after elution the unit activity of five strains of bacteria was increased in 8 days. While, in contrast to our results, extracellular acid phosphatase was obtained after 6 days in *Bu. metallica*  $0.143 \mu\text{g ml}^{-1}$  and *E. asburiae*  $0.061 \mu\text{g ml}^{-1}$  in rock phosphate and *B. coagulans* II  $0.061 \mu\text{g ml}^{-1}$  as higher concentration and after 8 days in *B. coagulans* I  $0.097 \mu\text{g ml}^{-1}$  in rock phosphate and *E. asburiae*  $0.112 \mu\text{g ml}^{-1}\text{min}^{-1}$ , *B. megaterium*  $0.164 \mu\text{g ml}^{-1}$  as higher concentration than other strains respectively.

### Determination of alkaline phosphatase activity by phosphorous solubilizing bacteria

Extracellular alkaline phosphatase was obtained after 6 days in *B. megaterium* ( $0.159 \mu\text{g/ml/min}$ ), *Bu. metallica* ( $0.143 \mu\text{g/ml/min}$ ) in rock phosphate broth and *B. coagulans* II ( $0.148 \mu\text{g/ml/min}$ ), *Bu. metallica* ( $0.143 \mu\text{g/ml/min}$ ) as higher concentration and after 8 days in *B. coagulans* I ( $0.097 \mu\text{g/ml/min}$ ) in rock phosphate and *E. asburiae* ( $0.112 \mu\text{g/ml/min}$ ), *B. megaterium* ( $0.164 \mu\text{g/ml/min}$ ) as higher concentration than other strains respectively.

One unit of phosphatase is the amount which hydrolyses  $1 \mu\text{mol}$  of substrate per minute at acidic pH and temperature  $37^\circ\text{C}$

### In vitro testing of phytase producing capacity of bacteria in liquid assay and plate assay

The data from the quantitative determination of phytase activity in phytate medium showed that total phytase enzyme produced by *B. coagulans strain PBA 16* strains showed activity above  $0.008 \text{ U/ml}$  after 6 days. Whereas, after 8 days other isolates activity reduced expect *B. megaterium*, which is increased above  $0.003 \text{ U/ml}$ .

One unit of phytase is defined as the amount of enzyme that liberates one  $\mu \text{ mol}$  inorganic phosphate  $\text{mL}^{-1} \text{ min}^{-1}$  under the assay condition.

## VI. SUMMARY AND CONCLUSION

Five native cultures were screened for P solubilization and their P solubilizing index was worked out in Sperber agar media supplemented with TCP as source of phosphorus and observed that three isolates viz. *Bu. metallica*, *B. coagulans* and *B. megaterium* gave good halo than others. Whereas solubilization index was carried out in phytate medium was also showed good halo zone of two isolates.

P solubilization efficiency in liquid medium indicated that isolate *B. megaterium* and *E. asburiae* are found best and solubilize maximum amount of TCP releasing  $53.41 \mu\text{g/ml}$  P and  $51.78 \mu\text{g/ml}$  at 6 DAI respectively. For rock phosphate maximum P release  $103.58 \mu\text{g/ml}$  and  $68.80 \mu\text{g/ml}$  recorded on 6 DAI for isolates *B. coagulans* II and *B. megaterium* respectively. The overall results indicated that two native PSB isolates have been established as more potent cultures and have significantly importance for soil fertility and P fertilizer. Entire scenario of different experimentations signifies that, PSB isolate *B. megaterium* and *B. coagulans* II used as P-biofertilizer to

increase 'P' in soil and also used to increase crop yield with best potency for enhancement of soil fertility.

Selected two native PSB isolates one gram negative and one are gram positive viz. *B. megaterium* and *Bu. metallica* respectively, were further screened for organic acid production on media supplemented with pH indicator dye bromo phenol blue (BPB) primarily exhibited positive results of acid secretion. HPLC profiles for qualitative and quantitative analysis of organic acids showed presence of different organic acids viz. oxalic, gluconic, malonic, lactic, acetic, citric, 2-KG, butaric, propionic, malic and tartaric acid in culture filtrates of isolates among which gluconic acid was predominant in all the isolates tested. Isolate *Bu. metallica* found to produce highest amount of organic acid i.e.  $35,708.78 \mu\text{g/ml}$  on 5 DAI. Isolate *B. megaterium* also found to produce total  $5122.3 \mu\text{g/ml}$  of organic acid.

Among the all enzymatic activity indicate that extracellular phosphatase was produced by the five native isolates was noticed to be low compared to 'P' solubilizers sited in literature. All five cultures produce low acid and alkaline phosphatase and thus there was lesser hydrolysis of the substrate hence show lower activity.

Five native cultures of K and P solubilizers showed their K solubilizing index was carried out in Aleksandrov agar media supplemented with mica as source of mineral potash and observed that two isolates gave good zone of solubilization than others.

Potash mobilizing efficiency in Aleksandrov liquid media supplemented with mica as a source of mineral potash indicated that isolate *E. asburiae* was best potash mobilizer showing  $4.85 \mu\text{g/ml}$  of K release from feldspar at 6 DAI and  $4.50 \mu\text{g/ml}$  of K release from mica at 8 DAI.

Overall results indicated that five native cultures can significantly improves plant growth if used in field due to their PGPR activity like P and K solubilization. Entire scenario of different experimentation signifies that native isolates have best potency for 'P' & 'K' mobilizing and their by for the improvement of soil fertility ultimately for better crop productivity.

## REFERENCES

- [1] Aleksandrov, V. G., Blagodyr, R. N. and Iiiev, I. P. (1967). Liberation of phosphoric acid from apatite by silicate bacteria. *Mikrobiyol Zh.* (Kiev), 29: 111-114.
- [2] Ahmed, Hala F. S. and El-Araby, Magda M. I. (2012). Evaluation of the influence of nitrogen fixing, phosphate solubilizing and potash mobilizing biofertilizers on growth, yield, and fatty acid constituents of oil in peanut and sunflower. *African Journal of Biotechnology*, 11(43): 10079-10088.
- [3] Archana (2007). Studies on potassium solubilizing bacteria. M.Sc. Thesis submitted to the University of Agricultural Sciences, Dharwad.
- [4] Bae HD, Yanke LJ, Cheng, KJ, Selinger LB (1999). A novel staining method for detecting phytase activity. *J. Microbiol. Meth.* 39: 17-22.
- [5] B. C. Antanaitis & P. Aisen (1983). "Uteroferrin and the purple acid phosphatases". *Advances in Inorganic Biochemistry* 5: 111-136. PMID 6382957.
- [6] Beacham IR. Periplasmic enzymes in gram-negative bacteria. *Int J Biochem.* 1979;10:877-883.
- [7] Baouedene-Assali, F., J. Baratti, and G. P. F. Michel. 1993. Purification and properties of a phosphate-irrepressible membrane-bound alkaline phosphatase from *Zymomonas mobilis*. *J. Gen. Microbiol.* 139:229-235.

- [8] Barre, P., Velde, B., Abbadie, L. (2007). Dynamic role of "illite-like" clay minerals in temperate soils: facts and hypothesis. *Biogeochemistry*, 82: 77-88.
- [9] Craven PA, Hayasaka SS. (1982) Inorganic phosphate solubilization by rhizosphere bacteria in a *Zostera marina* community. *Can J Microbiol*;28:605-10.
- [10] Carmany DO, Hollingsworth K, Mc-Cleary WR. (2003) Genetic and biochemical studies of phosphatase activity of PhoR., *J Bacteriol*.;185:1112-1115.
- [11] Cho JS, Lee W Ch, Kang SH, Lee J Ch, Bok JD, Moon YS, Lee H G, Kim S Ch, Chio YJ (2003). Purification and characterization of a phytase from *Pseudomonas syringae* MOK1. *Curr. Microbiol.* 47: 290-294.
- [12] Chung, H., Park, C. H., M., Madhaiyan, M., Seshadri, S., Song, J., Cho, H. and Sa, T. (2005). Isolation and characterization of phosphate solubilizing bacteria from the rhizosphere of crop plants of Korea. *Soil Biology & Biochemistry*, 37: 1970-1974.
- [13] FAI (2007). Fertiliser Statistics 2006-2007. The Fertiliser Association of India, New Delhi.
- [14] Fiske, C.H. and Subbarow, Y. (1925). The colorimetric determination of phosphorous. *J. Biol. Chem.* 65: 375-380.
- [15] Gerhardt, P., Murray, R. G. E., Costelow, R. N., Nester, E. W., Wood, W. A., Kreig, N. P. and Phillips, G. B., (1981). *Manual of Methods of General Bacteriology*. American Society of Microbiology, Washington, D.C. pp. 400-450.
- [16] Girgis, M. G. Z., Khalil, H. M. A., Sharaf, M. S., (2008). In vitro evaluation of rock phosphate and potassium solubilizing potential of some *Bacillus* strains. *Australian Journal of Basic and Applied Sciences*, 2(1):68-81.
- [17] Glew, R. H., and E. C. Heath. 1971 a. Studies on the extracellular alkaline phosphatase of *Micrococcus sodonensis*. II. Factors affecting secretion. *J. Biol. Chem.* 246:1566-1574.
- [18] Han HS, Lee KD (2005) Phosphate and potassium solubilizing bacteria effect on mineral uptake, soil availability and growth of eggplant. *Res J Agric Biol Sci* 1:176-180
- [19] Han HS, Supanjani, Lee KD (2006). Effect of co-inoculation with phosphate and potassium solubilizing bacteria on mineral uptake and growth of pepper and cucumber. *Plant Soil Environ* 52:130-136
- [20] Halder AK, Chakrabarty PK. Solubilization of inorganic phosphate by *Rhizobium*. *Folia Microbiol* 1993;38:325-30.
- [21] Hulett, F. M., E. E. Kim, C. Bookstein, N. V. Kapp, C. W. Edwards, and VOL. 62, (1996). Phosphatases from a psychrophilic arthrobacter strain 3737
- [22] H. W. Wyckoff. (1991). *Bacillus subtilis* alkaline phosphatase III and IV. *J. Biol. Chem.* 266:1077-1084.
- [23] Howson, S. J. and Davis, R.P. (1983), production of phytase- hydrolysing enzyme by some fungi, *Enzyme Microb, Technol.* 5: 377-382.
- [24] Jha, B.K., Pragash, M.G., Cletus, J., Raman, G. and Sakthivel. (2009). Simultaneous phosphate solubilization potential and antifungal activity of new fluorescent *Pseudomonas* strains, *P. aeruginosa*, *P. plecoglossicida* and *P. mosselii*. *World J Microbiol Biotechnol.* 25:573-581.
- [25] Kobori, H., and N. Taga. (1980). Extracellular alkaline phosphatase from marine bacteria: purification and properties of extracellular phosphatase from a marine *Pseudomonas* sp. *Can. J. Microbiol.* 26:833-838.
- [26] Lian, B., Fu, Mo, D. M. and Liu, C. Q. (2002). A comprehensive review of the mechanism of potassium release by silicate bacteria. *Acta Mineral Sinica*, 22: 179-183.
- [27] Liu, D., Lian, B and Dong, H., (2012). Isolation of *Paenibacillus* sp. and assessment of its potential for enhancing mineral weathering. *Geomicrobiology Journal*, 29: 413-421.
- [28] Memon, Y. M., Fergus, I. F., Hughes, J. D., Page, D. W. (1988). Utilization of non-exchangeable soil potassium in relation to soil types, plant species and stage of growth. *Australian Journal of Soil Research*, (26): 489-496.
- [29] Mikhailouskaya, N. and Tcherhysh, A. (2005). K-mobilizing bacteria and their effect on wheat yield. *Latvian Journal Agronom*, 8:154-157
- [30] Mehta, S. and Nautiyal, C.S. (2001). An efficient method for qualitative screening of Phosphate-solubilizing bacteria. *Curr Microbiol.* 43: 51-56.
- [31] Nomoto, M., M. Ohsawa, H.-L. Wang, C.-C. Chen, and K.-W. Yeh (1988). Purification and characterization of extracellular alkaline phosphatase from an alkalophilic bacterium. *Agric. Biol. Chem.* 52:1643-1647.
- [32] Olsen, S.R. (1954). In: Estimation of available phosphorous in soils by extraction with sodium carbonate. U.S.D.A., Washington, D.C., Circ. pp: 939.
- [33] Panday, A. Szakacs, A. Soccol, C.R. Rodriguez-leon, J.A. Soccol, V.T., 2001. Production, purification and properties of microbial phytase. *Biores. Technol.* 77: 203-214
- [34] Powar VK, Jagannathan V (1982). Purification and properties of phytate-specific phosphate from *Bacillus Subtilis*. *J. Bacteriol.* 151: 1102-1108.
- [35] Priyanka Parmar, S. S. Sindhu, (2013) Potassium Solubilization by Rhizosphere Bacteria: Influence of Nutritional and Environmental Conditions. *Journal of Microbiology Research* 2013, 3(1): 25-31
- [36] Richardson A, Pankhurst C, Doube B, Gupta V and Grace P (1994). Soil microorganisms and phosphorus availability. *Soil biota: management in sustainable farming systems* 50-62.
- [37] Rodriguez, H. and Fraga, R. (1999). Phosphate solubilizing bacteria and their role in plant growth promotion. *Biotech Adva.* 17:319-339.
- [38] Rossolini GM, Schippa S, Riccio ML, Berlutti F, Macaskie LE, Thaller MC (1998). Bacterial nonspecific acid phosphohydrolases: physiology, evolution and use as tools in microbial biotechnology. *Cell Mol Life Sci.*;54:833-850.
- [39] Rodriguez H, Fraga R (1999). Phosphate solubilizing bacteria and their role in plant growth promotion. *Biotechnol. Adv.* 17: 319-339.
- [40] Singh M.K., Singh, D.P., Mesapogu, S., Babu, B.K. and Bontemps, C. (2011). Concomitant colonization of nifH positive endophytic *Burkholderia* sp. in rice (*Oryza sativa* L.) promotes plant growth. *World J Microbiol Biotechnol.* 27:2023-2031.
- [41] Sugumar P and Janartham B (2007). Solubilization of potassium minerals by bacteria and their effect on plant growth. *World Journal of Agricultural Sciences* 3(3) 350-355.
- [42] Sheng XF, Huang WY and Yin YX (2003). Effects of application of silicate bacteria fertilizer and its potassium release. *Journal of Nanjing Agricultural University* 23 43-46.
- [43] Sheng, X. F., (2005). Growth promotion and increased potassium uptake of cotton and rape by a potassium releasing strain of *Bacillus edaphicus*. *Soil Biology & Biochemistry*, 37: 1918-1922.
- [44] Sparks, D.L., Huang, P.M. (1985). Release of soil potassium by weathering reactions. In: Munson RD (ed) Potassium in agriculture. American Society of Agronomy, Madison, WI, pp: 202-276.
- [45]
- [46] Thaller MC, Berlutti F, Schippa S, Lombardi G, Rossolini GM. b (1994) Characterization and sequence of PhoC, the principal phosphate-irrepressible acid phosphatase of *Morganella morganii*. *Microbiology*.;140:1341-1350
- [47] Thaller MC, Berlutti F, Schippa S, Iori P, Passariello C, Rossolini GM. a (1995). Heterogeneous patterns of acid phosphatases containing low molecular mass polypeptides in members of the family Enterobacteriaceae. *In J Syst Bacteriol*.;45:255-261.
- [48] Yamane, K., and B. Maruo, (1978). Alkaline phosphatase possessing alkaline phosphodiesterase activity and other phosphodiesterases in *Bacillus subtilis*. *J. Bacteriol.* 134:108-114.

#### AUTHORS

**First Author** – Sajidmohammad A Saiyad, Shri P.M. Patel  
institute of P.G. studies & research in science, India

**Second Author** – Dr. Yogeshvari K Jhala, Department of  
agricultural microbiology, Anand agricultural university, India

**Third Author** – Dr. R. V. Vyas, Department of agricultural  
microbiology, Anand agricultural university, India



# A comprehensive comparison of SQL and MongoDB databases

Rajat Aghi, Sumeet Mehta, Rahul Chauhan, Siddhant Chaudhary and Navdeep Bohra

Department of Computer Science, Maharaja Surajmal Institute of Technology, Janakpuri, N.delhi 110058, India

**Abstract-** Since time immemorial, one of the most heavily needed and relied upon functionality of computers has been the memory. Although the technical aspects and the implementation methods may vary, most computers these days have the necessary hardware to process information and safe-keep it to be used in future as and when required. Database Management Systems (DBMS) are higher-level software programs that work with lower-level application programming interfaces (APIs) that take care of these operations. To help solving different kinds of problems, new kinds of DBMSs have been developed (e.g. Relational, NoSQL, etc.) along with applications programs implementing them (e.g. MySQL, PostgreSQL, MongoDB, Redis, etc). In this paper we aim at comparing both the database options for various CRUD operations namely Create, Read, Update and Delete for small and large datasets and then use this analysis to decide which database to use for any given set of data.

**Index Terms-** comparison between SQL and NoSQL, comparison between SQL and MongoDB, performance comparison of SQL and MongoDB, SQL or NoSQL.

## I. INTRODUCTION

**D**atabase Management System is an umbrella term that refers to all sorts of completely different tools (i.e. computer programs or embedded libraries), with different and unique ways of working. These applications handle, or assist in handling and dealing with multiple sets of information at the same time. Since information (or data) can exist in various shapes and sizes, multiple DBMS' have been developed, along with numerous database applications, since the latter half of the 21st century to help in meeting different programming and computerisation needs. Database management systems are based on **database models**: structures defined for handling the information or data. Every new DBMS, along with the applications created to implement their methods, work in different ways with regards to definitions and storage and retrieval operations of the said information.

Although there are numerous solutions that implement different DBMS', each period in history has seen small amount of choices rapidly become extremely popular and stay in use for a long time, with probably the most predominant choice over the past couple of decades being the **Relational Database Management Systems** (RDBMS).

The remainder of the paper is organised as follows:

Section 2: An overview of the existing database models

Section 3: Comparative analysis between SQL and MongoDB for various data sets

Section 4: Conclusion based on the performed analysis

## II. OVERVIEW OF THE EXISTING DATABASE MODELS

Each database system implements a different database model to logically structure the data that is being managed. These models are the first step and the biggest determiner of how a database application will work and handle the information it deals with. There are quite a few different types of database models which clearly and strictly provide the means of structuring the data, with most popular probably being the Relational Model. Although the relational model and relational databases are extremely powerful and flexible - when the programmer knows how to use them, for many, there have been several issues or features that these solutions never really offered. Recently, a series of different systems and applications called NoSQL databases started to gain popularity, expeditiously, with their promise of solving these problems and offering some very interesting additional functionality.

### 2.1 The relational model

Introduced in 1970s, the relational model offers a very mathematically-adapt way of structuring, keeping, and using the data. It expands the earlier designs of flat model, network model, et cetera by introducing means of relations. Relations bring the benefits of group-keeping the data as constrained collections whereby data-tables, containing the information in a structured way (e.g. a Person's name and address), relates all the input by assigning values to attributes (e.g. a Person's ID number).

Thanks to decades of research and development, database systems that implement the relational model work extremely efficiently and reliably. Combined with the long experience of programmers and database administrators working with these tools, using relational database applications has become the choice of mission-critical applications which cannot afford loss of any information. Despite their strict nature of forming and handling data, relational databases can become extremely flexible and offer a lot, granted with a little bit of effort.

### 2.2 The model-less (NoSQL) approach

The NoSQL way of structuring the data consists of getting rid of the constraints imposed by the relational model, hence liberating the means of keeping, querying, and using information. NoSQL databases, by using an unstructured (or structured-on-the-go) kind of approach, aim to eliminate the limitations of strict

relations, and offer many different types of ways to keep and work with the data for specific use cases efficiently (e.g. full-text document storage). By eradicating the strictly structured data keeping style defined within the relational model, these DB systems work by offering a much more freely shaped way of working with information, thus providing a great deal of flexibility and ease -- despite the fact that they come with their own problems, some serious considering the important and indispensable nature of data.

### III. COMPARITIVE ANALYSIS BETWEEN SQL AND MONGODB FOR VARIOUS DATA SETS

The project was coded in PHP and using Wamp Server, it was simulated on Windows machine to be able to use Apache server and MySQL. For MongoDB, NodeJS was used to be able to use MongoDB on the Windows machine. The data was initially inserted manually and later large datasets were taken from free data sources thereby saving time in creating huge data for analysis. Later the time in seconds were retrieved for each operation and duly noted. The specifications for the three datasets are:

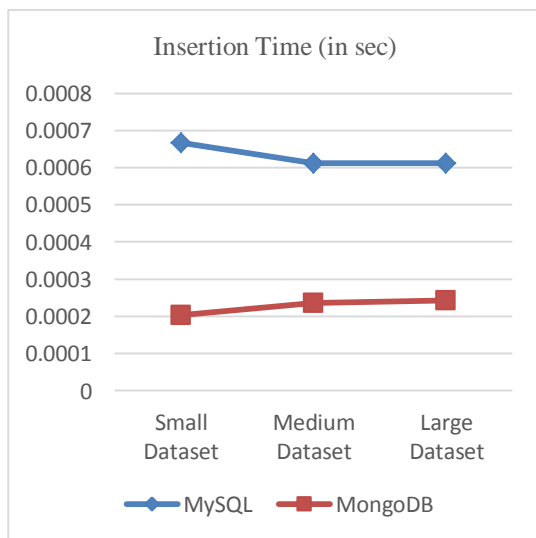
- a) *Small Dataset*: 10 rows and 2 columns
- b) *Medium Dataset*: 400 rows and 35 columns
- c) *Large Dataset*: 2000 rows and 20 columns

#### 3.1 Insertion Time

The table below depicts the insertion time of various data into the two databases.

**Table 1- Insertion Time**

Data Size	Time in MySQL (in sec)	Time in MongoDB (in sec)
Small	0.000668045	0.000203108
Medium	0.000612954	0.00023527
Large	0.000612974	0.000242857



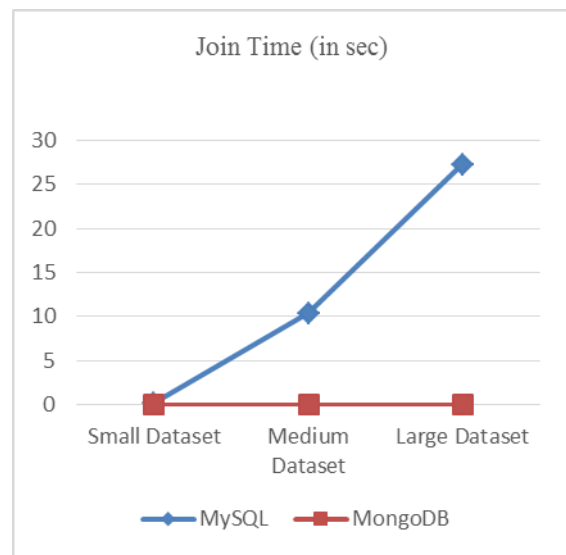
**Figure 1- Chart Depicting Insertion Time**

#### 3.2 Join Time

The table below depicts the query time of various data into the two databases

**Table 2- Join Time**

Data Size	Time in MySQL (sec)	Time in MongoDB (sec)
Small	0.23942999	0 (No Joins Required)
Medium	10.37390231	0 (No Joins Required)
Large	27.24617983	0 (No Joins Required)



**Figure 2- Chart Depicting Join Time**

#### 3.3 Retrieval Time

The table below depicts the insertion time of various data into the two databases.

**Table 3 – Retrieval Time**

Data Size	Time in MySQL (sec)	Time in MongoDB (sec)
Small	0.000838741	0.002098083
Medium	0.001597839	0.005849808
Large	5.270938449	6.2942504



AUTHORS

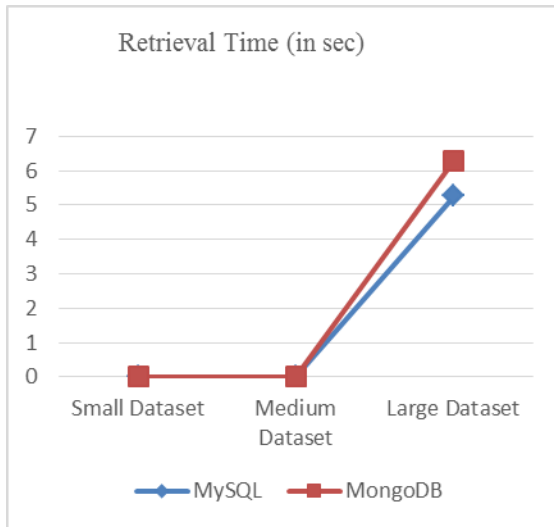
**First Author** – Rajat Aghi, B.Tech(cse), Maharaja Surajmal Institute of Technology and rajataghi@gmail.com.

**Second Author** – Sumeet Mehta, B.Tech(cse), Maharaja Surajmal Institute of Technology and sumeetmehta@gmail.com.

**Third Author** – Rahul chauhan, B.Tech(cse), Maharaja Surajmal Institute of Technology and Rahulchauhan\_20@yahoo.co.in.

**Fourth Author** – Siddhant Chaudhary, B.Tech(cse), Maharaja Surajmal Institute of Technology and siddhant31593@gmail.com.

**Fifth Author** – Navdeep Bohra, B.Tech, Maharaja Surajmal Institute of Technology and navdeepbohra@gmail.com.



**Figure 3 - Chart Depicting Retrieval Time**

#### IV. CONCLUSION BASED ON THE PERFORMED ANALYSIS

Based on the above analysis, the following conclusions can be drawn:

1. For small datasets, MySQL performed better in retrieval time.
2. For large datasets, there was minor difference between MySQL and MongoDB.
3. Insertion time was always better for MongoDB.
4. For relational data where the data could be arranged in row and column format, MySQL performed better.
5. As the data grew non-relational or there were significant gaps in the data, MongoDB performed better.
6. For complex queries involving multiple joins, MongoDB performed significantly better than MySQL due to its data structure allowing it to accommodate any type of data.

If it is required to use medium data without complex queries and normal day to day functioning, then MySQL is a better but if the data is non-relational and may involve complex queries and joins if used in SQL, then MongoDB gives better performance for basic CRUD operations.

#### REFERENCES

- [1] B. Tudorica and C. Bucur, "A comparison between several NoSQL databases with comments and notes," in Roedunet International Conference (RoEduNet), 2011 10th, June 2011, pp. 1–5.
- [2] J. Han, E. Haihong, G. Le, and J. Du, "Survey on NoSQL database," in Pervasive Computing and Applications (ICPCA), 2011 6th International Conference on, Oct. 2011, pp. 363–366.
- [3] K. Chodorow and M. Dirolf, MongoDB: The Definitive Guide. O'Reilly Media, September 2010.
- [4] N. Leavitt, "Will NoSQL databases live up to their promise?" Computer, vol. 43, no. 2, pp. 12–14, Feb. 2010.
- [5] D. Bartholomew, "SQL vs. NoSQL," Linux Journal, no. 195, July 2010.

# Induction of apoptosis by a potent Betulinic acid derivative in Human colon carcinoma HT-29 cells

Debasmita Dutta\*, Ankita Sarkar\*, Biswajit Chakraborty\*\*, Chinmay Chowdhury\*\*, Padma Das\*

\*Cancer Biology and Inflammatory Disorder Division, CSIR-Indian Institute of Chemical Biology; 4, Raja S.C. Mullick Road, Kolkata, West Bengal, India

\*\*Chemistry Division, CSIR-Indian Institute of Chemical Biology, Kolkata, West Bengal, India

**Abstract-** Traditional medicines or herbal formulations can serve as the source of potential new chemotherapeutic drugs. Nowadays novel plant derived natural products have been designed to determine biological structure-activity relationships. A new family of betulinic acid derivatives were synthesized and the structure-activity relationship of the compounds was initially evaluated by comparing their *in vitro* cytotoxicity against 4 human cancer cell lines U937, HepG2, HT29, MCF-7 and non cancerous human PBMC. Betulinic Acid derivative, BC-SM-05 was the most potent inducer of apoptosis and the most effective inhibitor of cell growth and proliferation with IC<sub>50</sub> value 19.6  $\mu$ M for colon carcinoma cell line HT-29. In addition, BC-SM-05 at IC<sub>50</sub> concentration was also found to generate increased ROS production and caspases activation. Moreover, HT-29 cells treated with BC-SM-05 and stained with Hoechst 33258 showed formation of apoptotic bodies and DNA degradation whereas untreated cells had intact nuclei. All together our data indicates that BC-SM-05 induces apoptosis in HT-29 cells via mitochondrial dependent pathway may prove itself to be a potential therapeutic agent for colon cancer, providing a basis for the development of the compound as a novel anticancer agent.

**Index Terms-** Triterpenoids, Betulinic acid, Cytotoxic activities, Apoptosis, ROS, Caspase activation, DNA fragmentation.

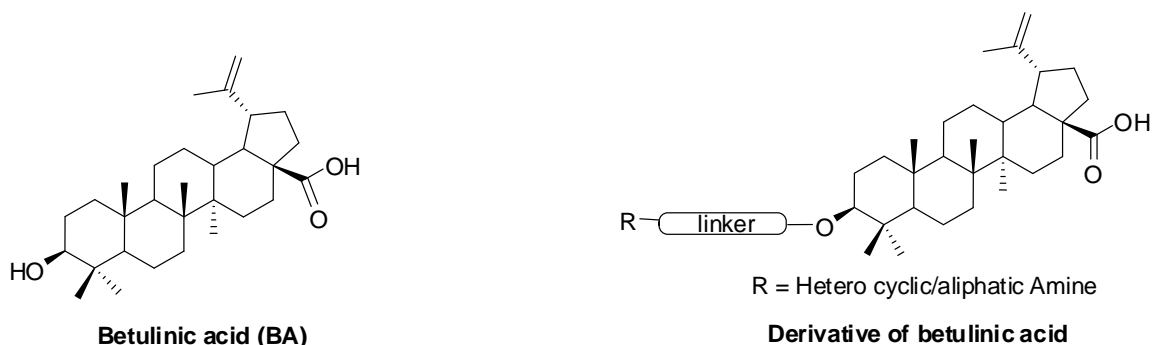
## I. INTRODUCTION

Cancer, one of the threatened most disease is a leading cause of death in the developed world and the second leading cause of death in the developing world (1). According to a recent report by the World Health Organization, there are now more than 10 million cases of cancer per year worldwide. Chemotherapy is still far from producing a satisfactory result especially in underdeveloped countries due to its adverse side effects, high cost, prolonged treatment protocol and alarming increase in the incidence of drug resistance. Traditional medicines or herbal formulations can serve as the source of potential new chemotherapeutic drugs. So, development of novel plant derived natural products and their derivatives for anticancer activity are increasing day by day. The present study is designed to determine anticancer activity of some newly synthesized

derivatives of natural triterpenoid compound (Betulinic Acid). Several triterpenoids, including ursolic and oleanolic acid, betulinic acid, celastrol, pristimerin, lupeol and avicins possess antitumor and anti-inflammatory properties. Some synthetic triterpenoid derivatives have been synthesized to improve antitumor activity such as cyano-3, 12-dioxooleana-1, 9 (11)-dien-28-oic (CDDO), its methyl ester (CDDO-Me), and imidazolide (CDDO-Im) derivatives. An increasing number of triterpenoids have been reported to exhibit cytotoxicity against a variety of cancer cells without manifesting any toxicity in normal cells. (2, 3, 4) Among them pentacyclic lupane type of triterpenoids are very important classes of natural products. The compounds of this class which includes betulin and betulinic acid were found to show significant antitumor activity on a broad panel of cancers (5, 6, 7). Betulinic acid was found to cause cancer cell death by induction of apoptosis involving caspases. Moreover it was demonstrated that betulinic acid was well tolerated in mice up to 500 mg/kg with no toxic effects (8). The induction of apoptosis is through the induction of changes in mitochondrial membrane potential, production of reactive oxygen species, and permeability of transition pore openings (9). These processes lead to the release of mitochondrial apoptogenic factors, activation of caspases, and DNA fragmentation (10, 11, 12). Betulinic acid, by an antioxidant mechanism tends to protect congenital melanocyte naevi cells from UV-C-induced DNA strand breakage independent of p53 and p21 (13). Betulinic acid induces weak inhibitory effects against topoisomerase I and IIa, but does not stabilize the topoisomerase IIa-DNA complex (14). Betulinic acid is active *in vivo* against TPA-induced tumors (15, 16).

It is found in the bark of several species of plants, principally the white birch (*Betula pubescens* syn. *alba*) (17) from which it gets its name. In 1995, betulinic acid was reported as a selective inhibitor of human melanoma. (18) Then it was demonstrated to induce apoptosis in human neuroblastoma *in vitro* and *in vivo* in model systems.(19) Currently, it is undergoing development with assistance from the Rapid Access to Intervention Development program of the National Cancer Institute.(20)

In this study, Betulinic acid was extracted from *Dillenia indica* which is also called Elephant apple.



**Scheme 1: Betulinic acid and its designed Derivative**

The diversity centres in betulinic acid are C-1, C-2, C-3, C-4, C-20 and C-28 positions and the derivatives resulted on various structural modifications at these positions screened for their anticancer activity.

In order to achieve the designed derivatives of betulinic acid, various nitrogenous heterocyclic (BC-SM-01 to BC-SM-04) or aliphatic amine (BC-SM-05) moieties were attached through linker with the hydroxyl group located at C3 position of betulinic acid and assessed the potency of these compounds to act as an inducer of cell death in different cancer cell lines and normal epithelial cell line.

## II. MATERIALS AND METHODS

### Materials

All chemicals were purchased from Sigma-Aldrich (St. Louis, Missouri, USA) except 3-(4,5-Dimethylthiazol-2-yl)-2,5-diphenyl-tetrazolium bromide (MTT) (USB Corporation, USA), HEPES (1X) liquid (Gibco® BRL, USA), Heat Inactivated Fetal bovine serum (Gibco® BRL, USA), DMSO (Merck, India), RPMI 1640 (Molecular Probes, Life Technologies Corp., USA), Hoechst 33258 (Calbiochem, USA) and CM-H2DCFDA 5-(and-6)-chloromethyl-2', 7'-dichlorodihydrofluorescein diacetate (Invitrogen, USA). All the tissue culture ware was obtained from Tarsons.

### Ethics Statement

Ethical approvals for the study and consent procedure were obtained from Internal Review Board (Ethical Committee on Human Subjects) of CSIR-Indian Institute of Chemical Biology. All clinical investigations have been conducted according to the principles expressed in the Declaration of Helsinki.

### Cell Lines

Four human cell lines U937-leukemic monocytic lymphoma, HT-29-colon carcinoma, MCF-7-breast adenocarcinoma, HepG2-Hepato carcinoma were collected from National Centre for Cell Sciences, Pune, India. All of cells were maintained in RPMI-1640 medium except HepG2 which was maintained in high glucose DMEM. Both the media were supplemented with 10% FBS and antibiotics (50 IU/ml penicillin G and 50 µg/ml streptomycin). The cells were incubated at 37°C in a humidified incubator containing 5% CO<sub>2</sub> and subcultured

every 72 h using an inoculum of 5 X 10<sup>5</sup> cells /ml. Cell viability (>95%) was confirmed by trypan blue exclusion.

### Isolation of Human Peripheral Blood Mononuclear Cells (PBMC)

PBMC were isolated from anticoagulated blood of six healthy donors by density gradient centrifugation using an equal volume of Ficoll-Hypaque (Histopaque-1077) at 400 x g for 30 mins. Then, PBMC were harvested from the interface and washed twice in phosphate buffered saline (PBS, 0.01 M, pH 7.4). After that resuspended in RPMI-1640 medium supplemented with penicillin (50 IU/ml), streptomycin (50 µg/ml) and 10% FBS. Cell viability was confirmed by trypan blue exclusion (>95%).

### Preparation of Betulinic Acid Derivatives

Methanolic extracts of Betulinic acid (BA) was prepared from of the *Dillenia indica* fruits according to literature procedure. (21) An analogue library was prepared by our chemistry collaborators based on betulinic acid and their structure-activity relationship (SAR) studies in cancer cells. Towards this objective, functionalisation at C-3 hydroxy of betulinic acid was carried out followed by "click reaction" resulting in the formation of new derivatives. These compounds were purified (>98% purity) by HPLC separations and identified using spectral analysis.

### Cell Viability Assay

The half maximal inhibitory concentration (IC<sub>50</sub>) is a measure of a compound effectiveness to inhibit biological or biochemical function. The MTT assay is based on the bio-reduction of the tetrazolium salt MTT into soluble purple formazan by mitochondrial dehydrogenase active enzymes, expressed only in metabolically active cells and therefore viable cells. This product can be assayed calorimetrically. The amount of formazan produced is therefore directly proportional to the number of viable cells present.

### Mitochondrial dehydrogenase

**MTT (Yellow) → Formazan (Purple)**

The cytotoxic activity of all betulinic acid derivatives dissolved in DMSO (final DMSO concentration <0.1%) were evaluated in U937, HT 29, HepG2, MCF-7 and PBMC using

MTT assay. Briefly, cells ( $1.25\text{--}2.5 \times 10^4$  cells/100  $\mu\text{l}$  of RPMI 1640 or high glucose DMEM medium/well) were seeded in 96-well tissue culture plates and incubated with DMSO dissolved betulinic acid derivatives (using 0-50  $\mu\text{M}$  concentration) for 48 h at  $37^\circ\text{C}$ , 5%  $\text{CO}_2$ . A solution of MTT (5 mg/ml) was prepared in 1X PBS (0.02 M, pH 7.2) and stored at  $-20^\circ\text{C}$  until used. It was stored in the dark. After treatment, cell viability was measured by adding 20  $\mu\text{l}$  MTT (5 mg/ml in PBS) and incubated for 4 h at  $37^\circ\text{C}$ . Then 100  $\mu\text{l}$  DMSO was added to each well, resultant optical densities were measured at 540 nm in an ELISA Reader (BIO RAD, CA, USA). According to the specific absorbance that represented formazan production was calculated by subtraction of background absorbance from total absorbance. The mean percentage viability was calculated as follows:

$$\frac{\text{Mean specific absorbance of treated cells} \times 100}{\text{Mean specific absorbance of untreated cells}}$$

The results were expected as  $\text{IC}_{50}$  values which was enumerated by graphical extrapolation using Graph Pad Prism software (version 5, Graph Pad Prism software Inc, San Diego, CA, USA). Each experiment was performed at least three times and in duplicate.

### Measurement of Intracellular Reactive Oxygen Species (ROS)

Elevated level of ROS generation can damage DNA, protein and lipids and ultimately causes apoptosis of cancer cells. To investigate the effect of BC-SM-05 i.e. the lead molecule on generation of ROS, CM-H2DCFDA—lipid soluble, membrane permeable non-fluorescent reduced derivative of 2, 7-dichlorofluorescein was used. This When chemically reduced, the dye remains non fluorescent but after cellular oxidation and removal of acetate groups by cellular esterase it becomes fluorescent and is measured by flow cytometry at an excitation wavelength of 485 nm and emits at 530 nm.

After treatment with  $\text{IC}_{50}$  concentration of BC-SM-05 for 0-2 h, cells were washed with PBS (2000 x g, 5 min), resuspended in PBS and then incubated with CM-H2DCFDA (5  $\mu\text{M}$  in 1X PBS) for 30 min at  $37^\circ\text{C}$  in dark. Then, cells were again washed and resuspended in 500  $\mu\text{l}$  of PBS. DCF fluorescence was determined by flow cytometry at an excitation wavelength of 488 nm and an emission wavelength of 530 nm. (FACS Calibur, Becton Dickinson, USA) using forward vs. side scatter to gate the cell population and a FL1 histogram to quantify fluorescence of viable cells. The subsequent analyses were done using BD CellQuest Pro software. To confirm the elevated levels of ROS induced by BC-SM-05 for the inhibition of ROS generation, cells were pre-incubated with N-Acetyl cysteine (NAC), an established anti-oxidant (2.5 mM) for 3 h before treatment with BC-SM-05 and analyzed. Mean fluorescence intensities (MFI) were obtained using the FACS Diva software.

### Caspase activity analysis

A family of cysteine proteases, caspases play the key role for activation of apoptotic pathway. Active caspases cleave the chromophore from the enzyme substrate which is measured as a proof of caspase activation. The enzymatic activity of caspase 8,

9, 3 was assayed in cell lysates (100  $\mu\text{g}$  protein in 50  $\mu\text{l}$  lysis buffer) using colorimetric assay kits as per the manufacturer's instructions. Briefly, control and BC-SM-05 treated (19.6  $\mu\text{M}$ ; 0–48 h) HT29 cell ( $2.5 \times 10^5/\text{ml}$ ) were washed with ice cold PBS, cell lysates were prepared and subsequently protein concentration was estimated. Lysates were combined with reaction buffer and incubated with specific colorimetric peptide substrates (Ac-IETD-pNA for Caspase-8, Ac-LEHD-pNA for Caspase-9, Ac-DEVD-pNA for Caspase-3; 4 mM, 5  $\mu\text{l}$ ) at  $37^\circ\text{C}$  for 6 h. The emission of paranitroanilide (pNA) was measured at 405 nm in an ELISA reader every 30 minutes for 6 h.

### Cellular and Nuclear Morphology Analysis

The Hoechst, a fluorescent stains are also commonly used to visualize nuclear damage. Hoechst 33258 is excited at around 350 nm and emits blue/cyan fluorescence light around an emission maximum at 461 nm. HT 29 cells were seeded ( $2.5 \times 10^5$  cells/ml) in a 6 well tissue culture plate. Drugs (BC-SM-05,  $\text{IC}_{50} = 19.6 \mu\text{M}$ ) were added. Plates were incubated for 48 hours at  $37^\circ\text{C}$  in a humidified 5%  $\text{CO}_2$  incubator. Hoechst 33258 was prepared in MilliQ water at a concentration of 5  $\mu\text{g}/\text{ml}$ . Cells were washed twice in PBS. Cell were fixed in 4% paraformaldehyde and incubated at  $4^\circ\text{C}$  for 30 minutes. Cells were again washed twice in PBS. Hoechst 33258 was added at a final concentration of 5  $\mu\text{g}/\text{ml}$  and incubated at  $37^\circ\text{C}$  for 30 minutes under dark conditions. Cells were again washed twice in PBS. (22) This was spotted on to poly-L-lysine coated slides and mounted using 50% glycerol. Slides were then analyzed in a laser scanning confocal microscope (Leica TCS SP2 System Leica Microsystem, Heidelberg, Germany, 100X). At least 20 randomly selected microscopic fields were observed per sample.

## III. RESULTS

### Cytotoxic activity of Betulinic Acid derivatives:

The cytotoxic activity of betulinic acid derivatives (BC-SM-01 to BC-SM-05) were evaluated by MTT assay on various cancer cells such as U937, HT-29, HepG2, MCF-7 as well as normal human PBMC (Table 1) using different concentrations (0-50  $\mu\text{M}$ ) of betulinic acid derivatives for 48 h.

As shown in Table 1, derivative BC-SM-05 exhibited minimum  $\text{IC}_{50}$  value (19.6  $\mu\text{M}$ ) among all the betulinic acid derivatives. So, we may conclude that derivative BC-SM-05 was the most potent inhibitor of HT-29 cells with  $\text{IC}_{50}$  value 19.6  $\mu\text{M}$ . DMSO concentration used to solubilize these compounds was 0.1% which had no effect on cell viability.

For our study, we synthesized a number of betulinic acid derivatives (BC-SM-01 to BC-SM-05) based on modifications (heterocyclic or aliphatic amine) at C3 position of betulinic acid. Interestingly, when methyl amine ( $-\text{CH}_2\text{NH}_2$ ) group was used for this derivative preparation (BC-SM-05), the highest cytotoxicity was observed against Human colorectal adenocarcinoma, HT-29 cancer cell line whereas negligible cytotoxic to normal human PBMC. Hereafter, we studied apoptotic pathway on HT-29 cell line only with BC-SM-05 as we found it as lead molecule.

### Compound BC-SM-05 causes excessive ROS generation:

Enhanced ROS generation is an established hallmark of apoptotic cells death that results in oxidative stress and cellular



damage. They are a by-product of a number of natural cellular processes such as oxygen metabolism and inflammation. Excessive ROS generation beyond a certain threshold level render cancer cells towards apoptosis. To determine whether BC-SM-05 induced apoptosis is mediated by oxidative stress; the intracellular level of ROS was measured in HT-29 cells. We found that BC-SM-05 (19.6  $\mu$ M for 0–2 h) was capable of producing ROS within 30 min in HT-29 cells and highest ROS generation found at 240 min (Fig. 1). To determine whether BC-SM-05 was the only factor responsible for excessive ROS generation, cells were pre-incubated with NAC (2.5 mM) for 3 h before treatment with BC-SM-05 (19.6  $\mu$ M; 30 min) and ROS was similarly quantified and then ROS level was found to near about control cells (Fig. 1). Values are expressed as Mean Fluorescence Intensity $\pm$ SEM of three independent experiments (\*\*p,0.01, \*\*\*p,0.001).

#### Caspases activation by BC-SM-05

During apoptosis cytochrome c is released from depolarized mitochondria. When cytochrome c is reached at cytosol, it causes activation of caspases, the main mediator of apoptosis. Caspase activation is a confirmatory evidence towards intrinsic pathway of apoptosis. Activation of caspases-8, -9 and -3 were measured using quantitative detection of colorimetric tetrapeptide substrates. As shown in Fig. 2A and 2B, activities of caspases -3 and -9 respectively increased significantly after 48 h treatment with BC-SM-05. In contrast, caspase-8 (Fig. 2C) did not increase significantly even after 48 h treatment of derivative BC-SM-05 as compared to control.

#### Compound BC-SM-05 causes DNA fragmentations

DNA degradation is the main characteristics of apoptosis. So, we have checked the nuclear fragmentation level of BC-SM-05 treated HT-29 cells using Hoechst 33258 dye. As shown in Fig:3, HT-29 cells treated with IC<sub>50</sub> (19.6  $\mu$ M) concentration of derivative BC-SM-05 resulted in gradual degradation of DNA and formation of apoptotic bodies in a time dependent fashion.

#### IV. DISCUSSION

Cancer cells that avoid apoptosis continue to proliferate uncontrollably, which results in an increased tumor mass. So, inducing apoptosis in cancer cells without affecting the normal cells is a key process to control cancer development and progression. As natural products are potential alternative source of safer chemicals to fight against cancer. We designed five derivatives of betulinic acid (BC-SM-01 to BC-SM-05) modified at its C3 position and found when methyl amine (-CH<sub>2</sub>NH<sub>2</sub>) group was attached to C3 position of betulinic acid (BC-SM-05), the highest cytotoxicity was shown against HT-29 cancer cells whereas negligible cytotoxic to normal human PBMC. Then we investigated that whether BC-SM-05 induce apoptosis in HT-29 cells by set up different hallmarked experiments on apoptosis like ROS measurement, Caspase Activity Assay and Nuclear morphology study.

#### V. CONCLUSION

We found BC-SM-05, modified with methyl amine (-CH<sub>2</sub>NH<sub>2</sub>) group attached at C-3 position of betulinic acid as the most potent inducer of apoptosis in HT-29 cells. We showed that BC-SM-05 was key factor responsible for elevated level of ROS generation in HT-29 cells, also causes caspases activation. Furthermore, it triggered DNA degradation. All together our findings suggest that BC-SM-05 induces mitochondrial pathway dependent apoptosis in HT-29 cells.

#### CONFLICT OF INTERESTS

The authors declare no conflict of interest.

#### ACKNOWLEDGEMENT

The authors are thankful to Dr. Arun Bandyopadhyay, Senior Principal Scientist, Cell Biology and Physiology Division, CSIR-Indian Institute of Chemical Biology for extending his laboratory facilities. Financial supports from CSIR network projects (TREAT-BSC 0116) and Department of Biotechnology (DBT), New Delhi, India are gratefully acknowledged.

#### REFERENCES

- [1] Jemal, A; Bray, F, Center, MM, Ferlay, J, Ward, E, Forman, D (2011 Feb 4). "Global cancer statistics.". CA: a cancer journal for clinicians.
- [2] Petronelli, A., Pannitteri, G, Testa U. Triterpenoids as new promising anticancer drugs. *Anticancer Drugs* 2009; 20(10): 880-892.
- [3] Setzer WN, Setzer MC. Plant-derived triterpenoids as potential antineoplastic agents. *Mini Rev Med Chem* 2003; 3: 540–556.
- [4] Laszczyk MN. Pentacyclic triterpenes of the lupane, oleanane and ursane group as tools in cancer therapy. *Planta Med* 2009; 75: 1549–1560.
- [5] Fulda S, Jeremias I, Steiner HH, Pietsch T, Debatin KM (1999). Betulinic acid: a new cytotoxic agent against malignant brain-tumour cells. *Int J Cancer* 1999; 82:435–441.
- [6] Schmidt ML, Kuzmanoff KL, Ling-Indeck L, Pezzuto JM, Betulinic acid induces apoptosis in human neuroblastoma cell lines. *Eur J Cancer* 1997; 33:2007–2010.
- [7] Zuco V, Supino R, Righetti SC, Cleris K, Marchesi E, GambacortiPasserini C, Formelli F, Selective cytotoxicity of betulinic acid on tumour cell lines, but not normal cells. *Cancer Lett* 2002; 175:17–25.
- [8] Pisha E, Chai H, Lee IS, Chagwedera TE, Farnsworth NR, Cordell AC, Beecher CWW, Fong HHS, Kinghorn AD, Brown DM, Wani MC, Wall ME, Hieken TJ, Das Gupta TK, Pezzuto JM. Discovery of betulinic acid as a selective inhibitor of human melanoma that functions by induction of apoptosis. *Nat Med* 1995; 1:1046–1051.
- [9] Fulda S, Friesen C, Los M, Scaffidi C, Mier W, Benedict M, Nunez G, Krammer PH, Peter ME, Debatin KM, Betulinic acid triggers CD95 (APO-1/Fas)- and p53-independent apoptosis via activation of caspases in neuroectodermal tumours. *Cancer Res* 1997; 57:4956–4964.
- [10] Fulda S, Scaffidi C, Susin SA, Krammer PH, Kroemer G, Peter ME, Debatin KM. Activation of mitochondria and release of mitochondrial apoptogenic factors by betulinic acid. *J Biol Chem* 1998; 273:33942–33948.
- [11] Fulda S, Debatin KM. Betulinic acid induces apoptosis through a direct effect on mitochondria in neuroectodermal tumours. *Med Pediatr Oncol* 2000; 35:616–618.
- [12] Syrovets T, Buchele B, Gedig E, Slupsky JR, Simmet T. Acetyl-boswellic acids are novel catalytic inhibitors of human topoisomerase I and IIa. *Mol Pharm* 2000; 58:71–81.
- [13] Yasukawa K, Takido M, Matsumoto T, Takeuchi M, Nakagawa S. Sterol and triterpene derivatives from plants inhibit the effects of a tumour



- promoter, and sitosterol and betulinic acid inhibits tumour promotion in mouse skin two-stage carcinogenesis. *Oncology* 1991; 48:72–76.
- [14] Yasukawa K, Yu SY, Yamanouchi S, Takido M, Akihisa T, Tamura T, Some lupane-type triterpenes inhibit tumour promotion by 12-O-tetradecanoylphorbol-13-acetate in two-stage carcinogenesis in mouse skin. *Phytomedicine* 1995; 4:309–313.
- [15] Bringmann G, Saeb W, Assi LA, Francois G, Narayanan ASS, Peters K, Peters EM. Betulinic acid: Isolation from *Triphyophyllum peltatum* and *Ancistrocladus heyneanus*, antimalarial activity, and crystal structure of the benzyl ester. *Planta Med* 1997; 63:255–257.
- [16] Steele JCP, Warhurst DC, Kirby GC, Simmonds MSJ. In vitro and in vivo evaluation of betulinic acid as an antimalarial. *Phytother Res* 1999; 13:115–119.
- [17] Recio MC, Giner RM, Manez S, Gueho J, Julien HR, Hostettmann K, Rios JL. Investigations on the steroidal anti-inflammatory activity of triterpenoids from *Diospyros leucomelas*. *Planta Med* 1995; 61:9–12.
- [18] Huguet A-I, Recio MC, Manez S, Giner RM, Rios JL. Effect of triterpenoids on the inflammation induced by protein kinaseC activators, neuronally acting irritants and other agents. *Eur J Pharmacol* 2000; 410:69–81.
- [19] Fujioka T, Kashiwada Y, Kilkuskie RE, Cosentino LM, Ballas LM, Jiang JB, Janzen WP, Chen I-S, Lee KH. Anti-AIDS agents, Betulinic acid and platanic acid as anti-HIV principles from *Syzigium claviflorum*, and the anti-HIV activity of structurally related triterpenes. *J Nat Prod* 1994; 57:243–247.
- [20] Tan Y, Yu R, Pezzuto JM. Betulinic acid-induced programmed cell death in human melanoma cells involves mitogen-activated protein kinase activation. *Clinical Cancer Research* 2003; 9(7): 2866–75.
- [21] D. Kumar, S. Mallick, J. R. Vedasiromoni, B. C. Pal, Anti-leukemic activity of *Dillenia indica* L. fruit extract and quantification of betulinic acid by HPLC, *Phytomedicine*, 17 (2010) 431.
- [22] R. Roy, D. Kumar, B. Chakraborty, C. Chowdhury, P. Das, Apoptotic and Autophagic Effects of *Sesbania grandiflora* Flowers in Human Leukemic Cells, *Plos One* (2013) 8(8): e71672

#### AUTHORS

**First Author** – Debasmita Dutta, Research Scholar, Cancer Biology and Inflammatory Disorder Division, CSIR-Indian Institute of Chemical Biology; 4, Raja S.C. Mullick Road, Kolkata, West Bengal, India

**Second Author** – Ankita Sarkar, Trainee, Cancer Biology and Inflammatory Disorder Division, CSIR-Indian Institute of Chemical Biology; 4, Raja S.C. Mullick Road, Kolkata, West Bengal, India

**Third Author** – Biswajit Chakraborty, Research Scholar, Chemistry Division, CSIR-Indian Institute of Chemical Biology, Kolkata, West Bengal, India

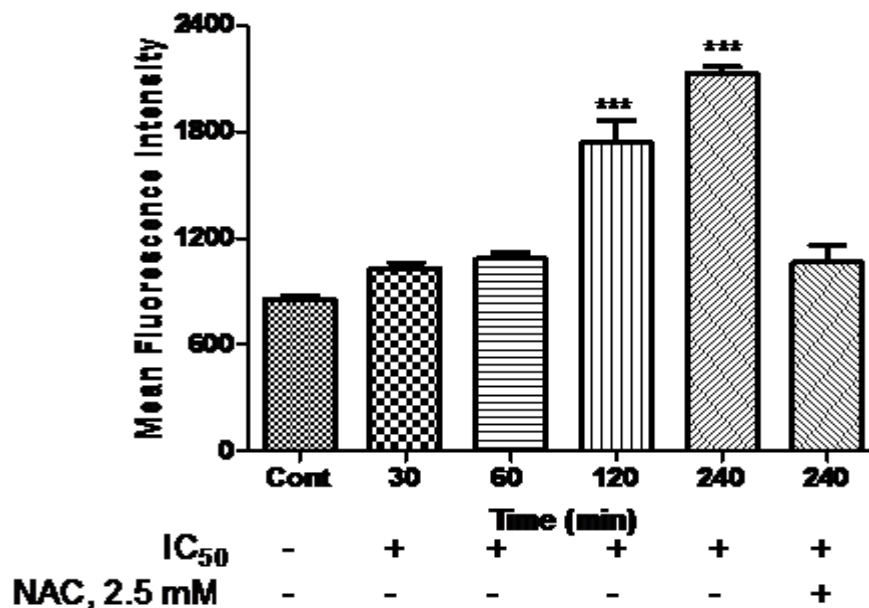
**Fourth Author** – Chinmay Chowdhury, Principal Scientist, Chemistry Division, CSIR-Indian Institute of Chemical Biology, Kolkata, West Bengal, India

**Correspondence Author** – Padma Das, Principal Scientist, Cancer Biology and Inflammatory Disorder Division, CSIR-Indian Institute of Chemical Biology; 4, Raja S.C. Mullick Road, Kolkata, West Bengal, India, Tel: +91-33-3324995899, Fax: +91 33 2473 5197, +91 33 2472 3967, E-mail: [padmadas2005@yahoo.co.in](mailto:padmadas2005@yahoo.co.in), [padmadas@iicb.res.in](mailto:padmadas@iicb.res.in)

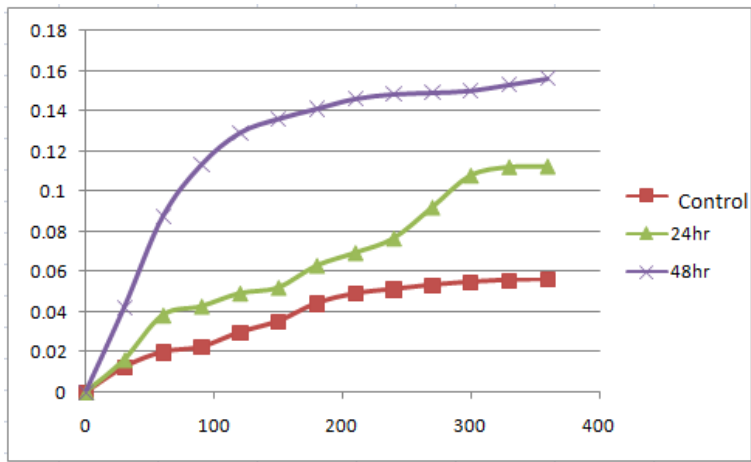
**Table 1: Cytotoxic activity of betulinic acid derivatives on different cancer cell lines**

Compounds	Cell growth inhibition in terms of IC <sub>50</sub> (μM)				
	U937	HT29	HepG2	MCF-7	PBMC
BC-SM-01	>50	38.2±0.9	49.8±0.5	>50	>50
BC-SM-02	39.98±0.7	>50	>50	>50	>50
BC-SM-03	45.8±0.4	36.9±1.3	>50	>50	>50
BC-SM-04	>50	39.7±2.2	>50	>50	>50
BC-SM-05	29.65±1.1	19.6±0.2	39.8±0.6	45.76±1.2	>50

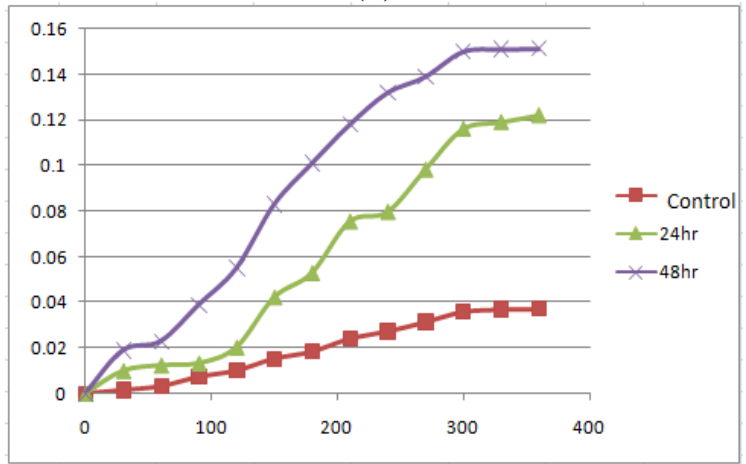
**Figure 1. Analogue BC-SM-05 triggers redox imbalance in HT 29 cells**



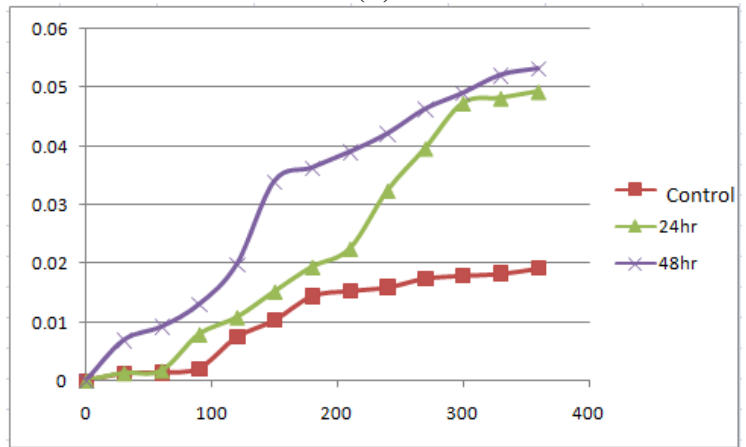
**Figure 2. Activation of caspases by BC-SM-05**



(A)

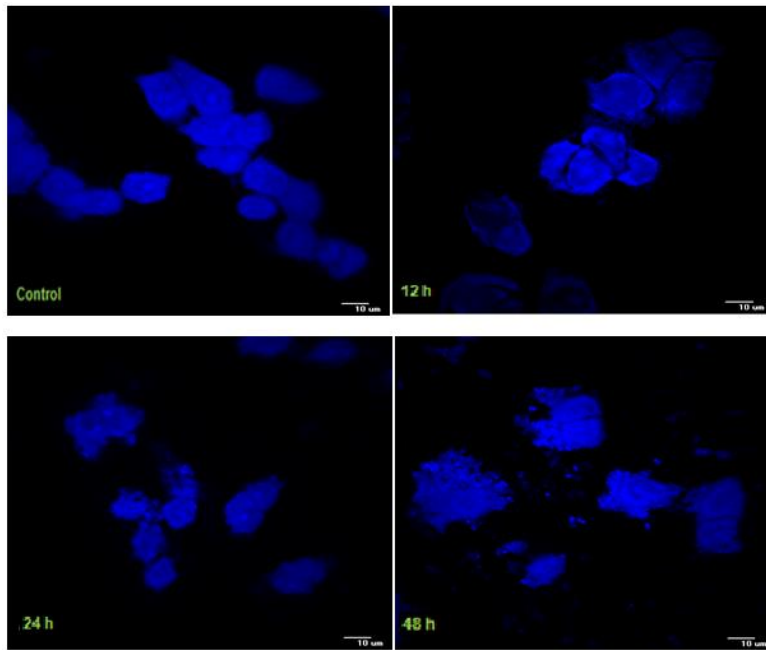


(B)



(C)

Figure 3: Nuclear fragmentation induced by 2c BC-SM-05



# Recycling of industrial waste and its impact on the environmental quality costs

Dr. Nasreldeen Gidam Elnagy

Majmaah University Saudi Arabia

**Abstract-** This research aimed to highlight what is the importance of environmental accounting and the recognition of environmental quality costs of industrial facilities ?, and where operations and production produces waste need to take measures including disposal of this waste operations ?, and how to discharge , either dumped or incineration or landfill or drown in the surrounding environment without incurring any material reward for this: leading to causing damage can accumulate and become great in the end, so there was a need to reconsider how to get rid of them by recycling the waste so as to diminish the claim by communities to download contaminated facilities more environmentally responsible by the costs to the environment spontaneously. We will address the budget proposal, including the number of industrial environmental costs: and make arrangements for after rooming directives management usually are as follows: -

1 target / plan for the annual production (product types and volume of products).

2 / light that determines the expected output and the cost of materials used in production quantities.

3 / also specify other direct and indirect costs and overhead costs as the volume of activity.

4 / The competent authorities of the environment based on the development of appropriate financial estimates for the work of research and development and mechanisms to measure damage to the environment and the fight against environmental pollution and all the necessary protection of the environment within the annual budget of the company until the adoption and exchange them when the lieutenant.

5 / then calculates the cost per unit produced and the profit margin is added to determine the selling price to determine the overall size of the company's profits during the year to achieve This budget is a road map for each company's products are the clarification of proceeds of the sale and the cost of production and the size of the more profitable overall also shows where production costs and other service departments and the costs of marketing and the costs of environmental quality costs taking with which the size of the proceeds from the recycling and participation in reducing the environmental cost of size and then find the net estimated to achieve profits.

In this section also will run the most important aspects of accounting, through which the researcher suggests model helps to incorporate environmental costs in the financial statements and also lists industrial costs and the size of the participation of recycling in the budget.

## I. OBJECTIVES OF RESEARCH

There are several reasons for the interest in the quality of environmental costs, including the following:

1. Environmental costs are the cost of the quality of high-value, in addition to the rapid and high growth.

2. Considers environmental costs typically vague and difficult to account.

3. Additions environmental costs of polluting industries to indirect costs, so must accountants distribution of these costs more fairly on activities causing pollution.

4. Increase awareness that led to the social and legal claims to the statement of account and environmental costs and the quality of disclosure.

5. The importance of accounting reports preponderant feed, provide management with information that helps to identify the inputs, processes and outputs, and determine the pricing system.

6. The attic is the recycling of industrial environment is of great significance in reducing the costs of environmental quality waste

7. As this study focused on the types of costs are several types of environmental pollution, for example, but not limited to: air pollution, and pollution chemical, and water pollution, noise pollution, pollution and visual pollution, radioactivity ... etc., so seeks accounting for environmental work estimates of costs and benefits efforts associated with them.

Environmental costs are divided generally into an environmental direct costs and indirect environmental pollution resulting from the work of the facilities.

The cost of environment-related categories based on versions of the International Federation of Accountants is represented as follows (IFAC, 1998):

1. Purchase of natural resources such as costs, water and other materials that are converted to products.

2. The purchase costs (and sometimes treatment) energy, water, and other materials that become a production output, not the product (irregularities and emissions).

3. irregularities and emission control costs, including the costs of eating, processing, and disposal of irregularities, emissions and costs of reclamation, and compensation associated with environmental damage, and any costs to comply with legislation Decontamination.

4. The costs of prevention and other environmental management costs, and include preventive environmental management activities such as, projects and plans for cleaner production. It also includes administrative and environmental activities and other costs such as environmental customization, systems and environmental measurement, environmental and communication, and any other appropriate activities.



5. Research and development costs, including research and development projects related to environmental matters costs

6. Costs less visible (less tangible costs), and include both internal and external costs associated with the matters at least visible. Examples include bear legal responsibility, and future legislation, and the company's image in front of the community.

Also focused on this study, the objectives of environmental accounting that the pollution impact is not limited to a specific environment or even on a given territory itself, but up the whole world to cover the impact on the level of global environmental variables, for example, the ozone hole and global warming, and the erosion of tropical forests, the consumption of petroleum, and freshwater resources.

If the environmental accounting application in enterprises - including private industry - positively affect the economies of the countries and installations itself and its reputation, it also includes a statement that there are positive effects of this particular with regard to the level of productivity application. I have discovered facilities that improve efficiency in the use of energy, water and other raw materials leads not only to environmental improvements (reduced use of resources, and reduce emissions of harmful emissions), but also lead to saving money significantly, due to the decrease in the purchase of raw materials and waste treatment costs.

## II. HYPOTHESES

1 - The concept of environmental quality costs a significant impact on the manifold on the lives of individuals within the industrial companies and thus can achieve quality by adding the yield of recycling of synthesizer's industrial environment

2 - Accounting Measurement more convenient to measure the environmental quality involving several aspects of the costs should be taken into account. It is quantitative, financial and descriptive side. Especially in companies that practiced with negative environmental impact and clear activities

3 - Cost accounting concepts from within the system, which must be exercised on the activity within companies Industry

## III. SUGAR BIO PRODUCT IN SUDAN (ETHANOL PRODUCT)

Until now, the only plant that produces bio-ethanol in Sudan is Kenana factory in White Nile State 340 kilometers south of Khartoum state, was inaugurated in the (April 2009).

A study prepared by the Kenana Sugar Company that the productive capacity of fuel ethanol from sugar projects currently at about 110 million liters per year in the near future, will produce them Kenana alone, 65 million liters in the Sudanese Sugar Company produces 45 million liters, according to the study, «Sudan has capabilities and the potential for scientific and natural qualify because assume an advanced position in the field of global production of biofuels. And the availability of the sugar cane crop in vast areas of the country, in addition to future projects for the production of sugar, provides inputs to the industry ». And when the quantities produced, which is estimated at 110 million liters at the global product account shall be effective contribution as Molas is within the industrial environment residues

## Environmental cost information

Environmental costs as "identifying and quantifying the costs of environmental activities and supplies, and use that information in making environmental management decisions, in order to attempt to mitigate the negative environmental effects of activities and regulations."

As well as the environmental cost information in addition to the existing cost accounting procedures, or make the registration of environmental costs is an integral part of them and customize the processes and products net worth has been referred to the environmental cost accounting as a new accounting or green accounting (Green Accounting).

Environment when some researchers as "a system that includes all living things and the physical environment", researchers have known contemporaries environment as "the environment in which neighborhoods to live, composed of the earth, and its atmosphere, and it and the interior"

There were also other concepts:

1. Environment-in-law as a "biosphere, which includes living organisms, and the promise of resources and surrounded by air, water, soil and human hosted facilities

2. The environment in the economy as consisting of two foundations, industrial concrete element such as buildings, roads, machinery and equipment, and the element of industrial intangible such as laws and economic and political systems.

3. Intended environmental accounting as "a system for the production of information on the environmental performance and economic unity benefit stakeholders to make decisions, and that this accounting is a satisfactory response to the need for stakeholders in the unit to the same environmental dimension Information on the one hand, and in response to the effects of legislation on the organization of activity on the other hand "it is clear from the above definition that environmental accounting system, designed to provide information about the unit or facility helps to control it, and ensure that it fulfills its responsibility towards the environment efficiently.

4. The concept of environmental management accounting as is "that identify, collect, assess, analyze and work of the internal reporting and to provide information about the flow of materials, energy, and information related to environmental costs, and any other information relating to the adoption of environmental and traditional-making within the organization."

5. The concept at the Fifteenth International Conference of the International Organization for Control and Auditing environmental audit as "control the implementation of environmental programs by governments, and control their response to international commitments signed by" can be environmental review includes all the control patterns, and if policies or programs to control not available, it can SAI use financial control to sow awareness of the importance of environmental issues.

The concept of environmental pollution Environment Pollution

1. Pollution is "corrupting the components of the environment, so that the turn of useful elements to harmful elements, the impact of the loss-making in life, and often this is due to human through neglect or misuse."

2. Pollution is "the accumulation of harmful elements and undesirable"

3. Pollution is "the introduction of materials or energy in the environment by human and which are the cause of human exposure to health risks or harm living materials and ecosystems or damage to buildings or areas to enjoy, or interfere with the proper uses of the environment"

4. Pollution is "one of the outputs of production and consumption activities."

(A) That the pollution is caused by materials and energy and is considered one of the outputs of production and consumption activities.

(B) That the pollution has created a source or sources of human and therefore it represents an increase added by the human environment.

(C) That the pollution causes effects or damage directly or indirectly, of living organisms and the aesthetics of the environment.

(D) The seriousness of the pollution linked to the vast human resources and ecosystems its effects.

(E) That the pollution is not subject to control parties damaged, but can be subject to the control causing the pollution or third party activities (such as government).

And it can be for the researcher to know the pollution that cause a change in the environment that surrounds the organisms by nature and by the daily human activities which lead to some output that do not fit with the place in which the organism lives and lead to the emergence

Third: The sources of environmental pollution

Ecologists believe that the pollution sources and are intended to factors that are emitted from volcanoes and natural gas, which is made up in the air and gas

First Source: natural factors, the naturally occurring ozone, dust, and other natural resources, and with no income for a person out.

The second source: human factors, the factors that have rights is the main reason for the creation of pollution and ecological imbalance in the balance by the irrational use of the components of the ecosystem, and the impact of human factors on the environment in general and air pollution has increased particularly after the Industrial Revolution.

The effects of environmental pollution and risks

1. Increase the curative and preventive expenditures, and low GNP.

2. The impact on natural systems agricultural and fisheries productivity

3. The destruction of resources (such as soil, forests and water), the impact on the availability of economic resources and economic activity of the individual.

Social effects of environmental pollution:

1. Damage to public health.

2. uneven distribution of welfare where the damage is done and the biggest burden on low-income groups, and the damage caused by environmental pollution and destruction of humans, plants and animals, are not taken into account as one of the elements of well-being

3. The low visibility and thus the high proportion of incidents by - and treatment of this leads to an increase in industrial lighting costs.

Increase the costs of cleaning and repairing the damage to buildings and real property

#### IV. RECYCLING OF INDUSTRIAL WASTE AND ITS IMPACT ON THE ENVIRONMENTAL QUALITY COSTS

Recycling of industrial wastes exist since ancient in nature, industrial wastes are food for some animals

Since that identified the communities to environmental problems, many countries have taken action to recover the waste, as well as limit the spread of hazardous waste,

1. - Protect natural resources

2. - Create new jobs

3. -Protection of Nature and the economy in the raw materials.

However, there are also downsides, such as

The cost of labor: as industrial waste conversion, requires sorted by the quality of the conversion, glass materials, glass... etc.) and thus into the hands of many working, and even if there is an initial screening by the population (i.e. specialized containers to throw some kind of waste), the second count in necessary to get a good sort of the types of waste audit centers (plastic, glass, etc.). The additional burden for this process is usually the responsibility of municipalities and local communities, and thus the need for a fee to throw some waste.

Industrial waste management is monitoring and collection, transportation, processing and recycling of process or dispose of industrial waste, commonly used this term for the waste produced by human activities, states in this process and are to mitigate the negative effects of waste on the environment, health and general appearance. This process is also used to get the resources and the recycling, can include waste solids, liquid and gaseous radioactive materials processing

Waste treatment between developed and developing countries, and between urban and rural areas and between residential areas and industrial zones vary.

Non-hazardous waste treatment or population in major urban areas are usually the responsibility of the local government authorities, while the non-hazardous industrial and commercial waste treatment are usually the responsibility of the waste generator any product.

Recycling steps

Waste sorting: is the most important stage in the recycling where required to obtain a good quality of industrial materials well screening for domestic and commercial waste; because this material loses its properties in the event of presence of impurities than other types of materials, and requires sorting big labor, including creating many job opportunities.

The industrial waste collection and sorting in many ways, including: assembled houses, shops and sell them to the nearest scrap, or to the buyer of scrap roaming the streets, or collected by scavengers in garbage dumps.

Washing: Wash industrial materials are textured caustic soda, or liquid soap plus center

The hot water, where recycling requires that the material be free of industrial fats and oils and UFOs.

Waste Management - is the control and collection, transportation, processing and recycling of process or waste disposal countries in this process and to mitigate the negative effects of waste on the environment and public health and appearance. This process is also used to get the resources and the recycling, can include waste solids, liquid and gaseous radioactive materials processing.

Waste treatment differ between developed and developing countries, and between urban and rural areas and between residential areas and industrial zones

#### Re-biological waste recycling

Is the process of recycling organic materials such as plant and food waste and paper products, it can be recycled into compost and biological which is used in the biodegradation processes in agriculture. Gas output from this process is methane gas which is used in the emitted power. The purpose of this process is to accelerate the decomposition of organic materials. Biodegradation different ways there are aerobic and anaerobic. There hybrid routes between the two previous methods.

Energy recovery process in Germany: direct waste can be used for fuel can also be re-processed to obtain another type of fuel.

The conversion of solids, liquid and gas-to-energy through steam generation and thermal transformation and turbines. It can also be carbon.

#### Waste minimization to reduce consumption

The most important way to reduce waste is to reduce the production of these wastes, including the use of used products, and repair broken instead of buying new ones, and the use of the bags are multi-use cups instead of plastic and disposable, and the design of products by producers a way to facilitate recycling.

The most important way to reduce waste is to reduce the production of these wastes, including the use of used products, and repair broken instead of buying new ones, and the use of the bags are multi-use cups instead of plastic and disposable, and the design of products by producers a way that facilitates recycling

#### Waste of collection and transportation

Methods of waste collection between cities and states vary, and this service is often provided by local or by the private industrial sector and government authorities. In Australia the government follow the method of waste collection by the way is provided for each home three garbage containers: one for the

materials recyclable and one for organic materials and one of general waste.

In Europe in buildings where there are channels of garbage to pay down the buildings where there is a large content of garbage called this method

In Canada, the government follow the method of waste collection by the way also apply three garbage container system in most areas

In Taipei, the government is imposing taxes on household waste volume and achieved this way in order to minimize the volume of waste in the country

#### Awareness and education

Education and awareness in the field of waste processing is constantly growing because of the accumulation of waste, air pollution and the hole of the ozone layer and the depletion of natural resources and emitting poisonous gases and the spread of rodents in the accommodation, so it was declared, which carried out a number of universities through the establishment of good administrative Studies environment and programs waste.

Several ways to retrieve useful materials from solid waste and re-use them are available, and these ways: magnetic sorting where waste placed on the conveyor belt is exposed to a magnetic material to attract removable magnetic attraction metals. And sorting antenna where waste is isolated by density and size, and throw the waste into the air to be isolated similar materials by tossing distance. As well as the waste is isolated as components for remanufacturing after composting, where old cars returned to the iron and steel factories, broken glass to glass factories, timber plywood factory, old papers and waste cellulosic to the paper mill, plastics waste into plastics factory, aluminum cans, and waste membership to the unit power generation and bio-conversion (compost). And can take advantage of waste grease in soap and candles and lubricating oil industry. It follows from the bones, grease, feathers after being processed as food for animals. And can take advantage of cutting home furniture in large-size re-use and transport by specialized companies or individuals.

Waste retrieval or recycling existing since ancient in nature, wastes some organisms are considered food and other living organisms, has practiced human waste retrieval process since the Bronze Age, where he dissolves the metal material to be converted into new tool

<u>The scope of activity</u>	<u>Activity</u>
Required to obtain permits and approvals for the production of products that have environmental impacts, but within the limits of legal allowances efforts	Obtaining permits and approvals
Efforts and resources necessary to provide those responsible for the operation of pollution control devices individuals, as well as spare parts and other supplies to complete the maintenance operations.	Operation and maintenance of pollution control devices
Efforts to measure and test the waste or the result of operations and analysis to make sure no water, air, waste or polluting emissions pollution.	Measure the degree of pollution
Efforts and resources necessary to train workers to deal with the degree of contamination and provide training materials and training places	Training
Efforts to store harmful and flammable solid waste and compressed gases and measure materials storage areas until the disposition, as well as the disposition of the emissions that harm the environment	Waste storage and disposal
Efforts are needed to develop environmental plans and resources	Environmental planning activities

Notes from the previous figure that the performance of each activity of the previous activities involves taking some kind of expenses or cost for this activity, and therefore must strive for environmental costs reduced by excluding activities that do not

add value to the product, but environmental damage occur classification of environmental activities that add the value of the product

**Environmental cost Processes report**

The project		The local Environment		Statement
Partial	Total	Partial	Total	
	×		×	A / financial cost of the damage
	×		×	The cost of equipment
	×		×	The cost of buildings
	×		×	Agricultural crops damaged
	×		×	Has a production capacity
×		×		Lost livestock
×		×		The total cost of the physical damage
	×		×	B / human cost of damage
	×		×	Remedial costs
	×		×	Manpower costs pinned in the treatment period
	×		×	Early delegation costs
×		×		The total cost of human damage
	×		×	C / Total depreciation environmental assets
×		×		The total cost of environmental processes

Researcher finds that the cost of operations Environment Report includes the following:

A) Accounting information and data relating to cost being borne by each of the project and the surrounding environment as a result of the exchange of environmental processes among themselves.

B) What endures the project of human and material damage during production processes, either cost described

In the box to the environment surrounding environment are for the value of the societal burdens share the wealth and property of other parties and may be caused by the project.

A) The depreciation environmental assets, contain premium annual depreciation of machinery and equipment protection software environment. Through experiments that there could be a net or environmental return and

**List (report) the results of Environmental Processes for the period Ended**

Net economic profit		x x	Internal environmental costs	Xx	
			Physical damage	x x	
			Human damage		
Provided in the environmental		x x	Depreciation environmental assets	xx	
external costs		x x	Net economic profit		
In physical damage			External environmental costs	x x	
			Physical damage	x x	
In human damage	xxx		Human damage	Xx	
Net Loss environmental	Xx				x x
			Net yield environmental		

This figure above researcher believes that the impact of the investment costs of Environmental financial statements published information considered financial statements published the most important tools and means of communication accounting where are all the way delivery of information and data on business projects for the owners attention of the shareholders, creditors and lenders or bondholders government and relevant bodies (such as taxes)

The accounting disclosure about the performance of economic units in the field of protecting and conserving the environment (and sometimes called social disclose) must be in the form of lists, reports and attachments provide information about the financial position and income-generating activities pollution control budgets estimated capital and operating these activities reports of these activities, the proportion of investment spending and operational and the company's net income. Disclosure Social Corporate Social Disclosure can be defined as the provision of financial information and non-financial related to the interaction of the organization with the physical and social environment either mentioning within their annual reports or special events With details about the environment in kind Physical Environment, energy, human resources, products and issues related to the community and through the studies it is clear that the obligation to disclose Responsibility environmental highest in the United States and Britain.

As measured by the accounting disclosure about the environmental performance of companies in the field of pollution control and contain information on the expenses and the costs and performance indicators activities required to combat environmental pollution and disclosure in the form of lists and reports supplement or attachments annual company financial statements, and must include the disclosure of the following:

- 1) Financial statements to separate the activities of pollution control.
- 2) Discretionary budgets for capital and operating costs and expenses of running anti-pollution activities.
- 3) A statement of the kinds of production of harmful residues and maximum rates of contamination.

4) A statement of the issues uploaded on the company by those affected by the pollution.

5) Social performance report of the activities of pollution control.

6) A statement of the expected environmental obligations as a result of environmental pollution and the estimated costs to contend with the details of the current and capital.

7) A statement of the company's activities in the field of pollution control.

8) A statement of the proportion of spending on pollution control activities to the total capital of the company expectations.

9) A statement of operating expenses for the activities of pollution control to the net income of the company.

The financial statements include the company's environmental cost data (private investment) achieves utilitarian financial statements and this information available utilitarian if the following conditions are met:

- 1) The decision-maker's ability to trade-offs between different decisions.
- 2) to be a trade-off between decisions based on the expected utility.
- 3) Taking into account the value of the expected probability of benefits.
- 4) decisions that are arranged according to their utility for the decision maker because the investment costs directly related to environmental sustainable development.

Researcher believes that the most important ingredients of disclosure about costs environment of the facilities and the most comprehensive disclosure requirements:

1. minute metrics that identify environmental costs to get to the complete picture, and qualitative characteristics that provides all aspects related to environmental performance and accurate information for the programs and plans of information and the size of the implementation aggravated even more credibility.
2. always be a report explaining the plan to target established for each environment since the costs of construction and during operation and explains all the expenses of environmental performance and environmental disclosure is detailed for each facility services to the environment..



**Proposal to add revenue Investment environmental and recycling industrial environmental costs**

<u>Environmental costs of industrial company</u>				
Amount disbursed	The amount invested	Implementation details and effects	Data	S. No
Xxx			Environmental costs to reduce the environmental impacts resulting from the production and activity of the service	-10
			Details 1/2 the cost of environmental protection / total cost of the environment 3 / trading cost of resources	
Xxx			The cost of the environment in the first production, etc. -	-2
Xxx			Environmental costs and other administrative activities	-3
xxx			Environmental costs in research and development -	-4
xxx			Environmental costs in social activities	-5
xxx			Costs of environmental damage -	-6
	xxxxx		Total amount invested during the period	7
Xxxxx			Total amounts of research and development for the period	8
	xxxx		Return value of item 1.3	9
14,100,000	Xxxx		Return value of item 2	10

The figure shows preventive environmental costs to prevent environmental pollution including water, air, noise, odors and soil, climate change and other environmental change after obtaining the final outcome of the list of environmental costs and the grounds revenues Investment environmental and recycling and other revenue, add this result to the list of gains and losses

**V. THE RESULTS**

This research concluded that a number of results on the basis of the application of environmental quality cost accounting and moving here to the concept of environmental accounting year and the concept of threads to more privacy in this area, namely: the recognition of cost and environmental how the accounting treatment of these cost and reporting.

This research consider the benefits of implementing environmental costs of the quality of accounting at the multi-stakeholder, whether internal or external increasing attention to the environmental performance of the facilities, and examples of the owners of internal interests, staff and in particular those affected by pollution directly in the work environment, either external stakeholders, for example, does not limited to, the communities that are affected by local pollution, and groups interested in environmental activities, government agencies and regulators, along with the investing public

**VI. RECOMMENDATIONS**

1 / To be industrial wastewater resulting from the sugar industry water treatment specifically as an example of agro-industries and the remnants of Ethanol as one of the industry to recycle waste and utilized in any of agriculture as it is now in Brazil and other countries.

2 / The use of the remnants of the food industry and turn it into animal feed. And processing of farm waste in industrial companies

3 / Processing of agricultural waste to produce economic returns products such as wood panels and paper

4 / More efforts and spend money to protect the environment and also mandated to address the environment from pollution and chapters, and future costs of plans and programs for the future and planning and the costs of training for workers in the field of the environment and the costs of research and development of health in the field of environmental quality.

5 / This is the scope of the existing plant area or industrial facility, but the scope of the state and the world must work on the use of resources to good use and also reduce the risks of floods and reduce wastewater treatment and re or industrial waste and other treatment.

6 / Recycling of waste, which reduces the financial expenses in environmental sanitation and drainage also must train employees in environmental rehabilitation and also spending on

research and development and planning the future to reduce the environmental damage and also financially insurance on it

#### REFERENCES

- [1] Jasch C. "Environmental management accountant procedures and principles) (United) / (2001)
- [2] Nation division For Sustainable Development United Nation New York).
- [3] Environment Canada "Introduction Guide to environmental accounting Ohawa 1997.
- [4] Environmental issues in financial reporting London 1996
- [5] Management accountants of Canada "Tools and techniques of environmental Accounting" Ontario 1996
- [6] Procedure and principles New York 2001.
- [7] Institute of chartered accountants in England and Wales
- [8] United Nations Conference on trade and development accounting and • financial reporting for Environmental cost and liabilities" New York Un publication 1999 EC 2001.

#### AUTHORS

**First Author** – Dr. Nasreldeen Gidam Elnagy, Majmaah  
University Saudi Arabia

# Absorption Studies of Creatinine using End-Point Method by Optical Interference Wavelength Filter

Sreedhar Malleti\*, Dr. Bhujangarao A\*\*, Dr. Varaprasad PLH\*\*

\*Research scholar, Dept of Instrument Technology, college of engineering, Andhra University Visakhapatnam, Andhra Pradesh, India

\*\*Professor and Head of the dept of Instrument Technology, college of engineering, Andhra University Visakhapatnam, Andhra Pradesh, India

\*\*Former Professor, Dept of Instrument Technology, college of engineering, Andhra University Visakhapatnam, Andhra Pradesh, India

**Abstract-** Accurate measurement of Creatinine is very essential in order to pre diagnosis the renal functioning of human body. In this paper we introduced the measurement of creatinine by means of studying its equivalent absorption with the interaction of wavelength of light using endpoint method with the help of photometer.

**Index Terms-** absorption creatinine endpoint photometer

## I. INTRODUCTION

Creatinine reacts with Picric Acid in an alkaline medium to form an Orange coloured complex [1-5]. The rate of formation of this complex is measured by reading the change in absorbance at 505 nm in a selected interval of time and is proportional to the concentration of Creatinine. The reaction time and the concentration of Picric Acid and Sodium Hydroxide have been optimized to avoid interference from keto acids.

Creatinine + Picric Acid Orange coloured complex  
Breakdown product of 'creatinine phosphate' in muscle produces at constant rate by the body and filtered out of blood by kidneys poor filtration of urine results rise in creatinine level. Calculation of creatinine clearance is required in the urine and blood.

## II. REAGENTS

### COMPOSITION (TABLE 1)

Reagent No.	Reagent	Composition	Concentration
1	Picrate Reagent	Picric Acid Preservative	40 mM/L qs
2	Sodium Hydroxide	Sodium Hydroxide	200 mM/L
3	Creatinine Standard	Creatinine Stabiliser	2 mg/dl qs

## III. REAGENT STORAGE AND STABILITY

### Prior to reconstitution

Unopened Reagents 1,2 are stable at Room Temperature (15 – 30°C) and reagent 3 is stable at 2-8°C until the expiry date mentioned on the container label.

### After reconstitution

The "Working Reagent" is stable for 7 days at 2-8°C.

### Experiment Technical specifications and instrumentation

Sample volume: 70µl serum; 1 precision µl

Reaction temperature: 37 °C

Cuvettes size: 5X6X25; 5mm optical length;

Reaction volume: 180-500 µl

Photometric system: interference filters of with static – fibre optics

Lamp: tungsten-halogen lamp

Environment requirements: 15 °C-30 °C

Humidity: 35%-80%

Atm. pressure: 800hPa-1060 hPa

a) **Light source** : Tungsten halogen lamp

b) **Interference filter [6-7]**: it relies on optical interference to provide narrow band of radiation. Some times these are also called as Fabry Perot filters. The interference filters are available for the ultraviolet, visible and well into the infrared region. An interference filter consists of a transparent dielectric (frequently calcium fluoride or magnesium fluoride) that occupies between two semi-transparent materials. The thickness of the dielectric layer is carefully controlled and determines wavelength of the transmitted radiation. When a perpendicular beam of collimated radiation strikes this array, a fraction passes through the first metallic layer and the remainder is reflected. The portion that is passed undergoes a similar portion when it strikes the second metallic film. If the reflected portion of this second interaction is of the proper wavelength, it is partially reflected from the inner side of the first layer in phase with the incoming light of the same wavelength. The result is that this particular wavelength is reinforced, and most other wavelengths, being out of phase, undergo destructive interference.

d) **lens system and photometer**: This system consists of 9 optical paths with interference filters

Wavelengths: 340 nm, 405nm, 450nm, 510nm, 546nm, 578nm, 630nm, 670nm, 700nm  
Half band width: ≤12nm Measurement range: 0.1-4.0 Abs

Lamp: 12 V 50 VA tungsten-halogen

#### IV. METHODOLOGY

It is purely based [1-2] on end point reaction. the reaction reaches equilibrium after certain period. Because the equilibrium constant is very large, it can be considered that all substrates have changed into products, and the absorbance of the reacting liquid does not change any more. The absorbance change is proportional to the amount of the product present.

In this experiment the time when the reagent is added is  $t_1=22$  sec the time when the sample is added is  $t_2=24$  sec

The reaction starts when they are mixed. At  $t_3= 49$  sec the reaction reaches the equilibrium and the absorbance reading is taken. The reaction time is  $t_3-t_2= 49-24=25$  sec

The end point reaction is not subject to such condition changes as enzyme concentration, pH value and temperature, as long as the changes are not significant enough to affect the reaction time.

#### Absorbance

when a [6-7] parallel monochromatic light beam whose intensity is  $I_0$  goes through a flow cell (whose length is  $L$ ) containing a solution (whose concentration is  $C$ ), some photons are absorbed, and the intensity is attenuated from  $I_0$  to  $I$ , so the absorbance  $A$  of this solution is:

$$A = -\log I/I_0$$

Where,  $I/I_0 =$  transmittivity

The analyzer measures the light intensity through the photo-electric conversion, linear amplification and A/D conversion.

#### V. CALCULATING THE RESPONSE OF THE END-POINT REACTION SINGLE-REAGENT AND SINGLE WAVELENGTH

For the analyzer, the response ( $R$ ) is defined as the absorbance change before and after the reaction, or the absorbance change rate during the reaction process.

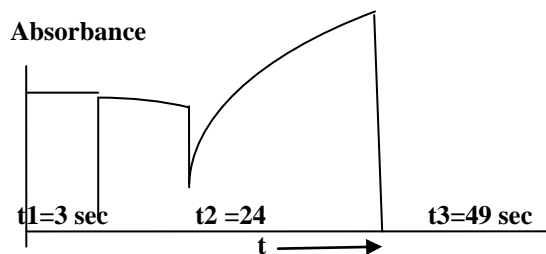


Fig 1:Endpoint reaction with single-reagent and single-wavelength

As shown in the above figure 1,  $t_1$  is the time when the reagent (volume:  $V$ ) is added.  $t_2$  is the time when the sample (volume:  $S$ ) is added. [10] The reaction starts when they are mixed. At  $t_3$  the reaction reaches the equilibrium and the absorbance reading is taken.  $t_3-t_2$  is the reaction time. So  $R = R_s - R_{SMPB}$ . Both  $R_s$  and  $R_{SMPB}$  are calculated with the formula  $R = At_3 - (K_1 \times A t_2 - 1)$ .

Where,

$R_s =$  Response of reaction mixture,  $R_{SMPB} =$  response of sample blank. If the sample blank has not been requested,  $R_{SMPB} = 0$

$A t_3 =$  Absorbance at  $t_3 = -63$

$A t_2 =$  Absorbance at the previous point before  $t_2 = -384$ ,  $K_1 =$  Single reagent test volume coefficient, If the start time of reaction is 0,  $K_1 = V/(V+S)$ ; otherwise,  $K_1 = 1$ ; If  $K_1 = 1$  since experiment was started at time  $t = 3$  sec Then, Response of reaction mixture  $R = -63 - 1(-564) = 501$

Reaction time is  $t_3 - t_2 = 49 - 24 = 25$  sec

#### VI. RESULTS OF EXPERIMENT (TABLE 2)[10]

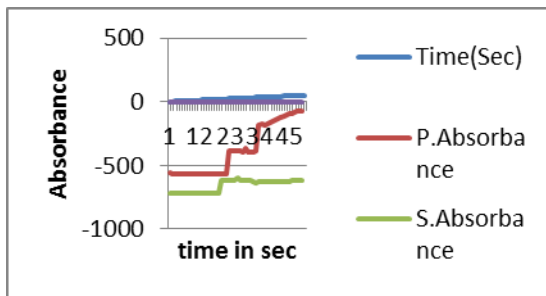
HUMAN SERUM (Female, age: 27 years):

S.NO	Time(Sec)	P.Wave length(nm)	P.Absorbance	S.wave length(nm)	S.Absorbance
1	1	26926	-561	14470	-716
2	2	26929	-562	14472	-717
3	3(*t1)	26933	-564	14469	-715
4	4	26939	-565	14471	-717
5	5	26935	-564	14476	-717
6	6	26936	-565	14476	-720
7	7	26938	-565	14475	-721
8	8	26938	-565	14476	-721
9	9	26940	-566	14478	-720
10	10	26940	-566	14479	-721
11	11	26941	-566	14476	-721
12	12	26942	-566	14478	-720
13	13	26942	-566	14479	-722
14	14	26943	-567	14476	-722

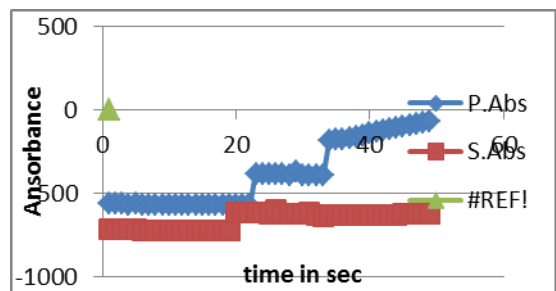
15	15	26940	-566	14478	-723
16	16	26944	-567	14479	-723
17	17	26947	-568	14477	-721
18	18	26946	-568	14480	-723
19	19	26948	-568	14480	-720
20	20	26945	-568	14481	-618
21	21	26948	-567	14481	-618
22	22	26945	-568	14478	-618
23	23	26948	-568	14481	-618
24	24(*t2)	26372	-384	14477	-618
25	25	26372	-385	14308	-619
26	26	26383	-387	14308	-602
27	27	26386	-387	14308	-621
28	28	26391	-391	14310	-621
29	29	26390	-370	14281	-622
30	30	26404	-391	14313	-620
31	31	26339	-393	14314	-618
32	32	26403	-392	14311	-626
33	33	26410	-390	14308	-634
34	34	26405	-185	14320	-630
35	35	26400	-178	14310	-630
36	36	25785	-179	14381	-629
37	37	25765	-170	14313	-629
38	38	25768	-159	14314	-627
39	39	25739	-149	14311	-629
40	40	25708	-140	14308	-629
41	41	25679	-129	14320	-627
42	42	25651	-122	14334	-629
43	43	25620	-113	14328	-627
44	44	25546	-104	14327	-626
45	45	25523	-97	14326	-624
46	46	25500	-89	14326	-622
47	47	25491	-86	14322	-621
48	48	25460	-75	14325	-621
49	49(*t3)	25441	-69	14322	-620

VII. GRAPHS

Graph-1: Response of Creatinine Absorbance with two different interference filters

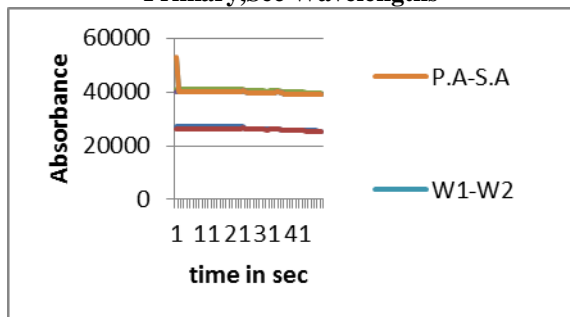


Graph-2 :X-Y :Scattered chart





**Graph:3 Chart Showing the variation of Absorpton Vs Primary,Sec Wavelengths**



### VIII. CONCLUSIONS

From the above observations it is concluded that by using optical spectrometry using tungsten halogen lamp as source and interference filters the creatinine absorption characteristics by UV light were observed. Moreover the reaction time for measuring creatinine was found to be 25 seconds and response of reaction mixture is at absorption of 501nm.

### REFERENCES

- [1] Reaction Kinetics, M. J. Pilling and P. W. Seakins  
1a) K.Spencer,"Analytical reviews in clinical biochemistry:the estimation of creatinine,"Ann.Clinical biochem.,vol.23,pp.1-25,1986.
- [2] Chemical Kinetics, K. J. Ladler
- [3] Instrumental analysis by Skoog,Holler and Crouch ,publisher Brooks/Cole/CENGAGE Learning page 204 to 206
- [4] Murray R.L: Non Protein nitrogen compounds, in Clinical chemistry: Theory, Analysis and Co Relation, Kaplan L.A. and Pesce A.J; Eds. C.V. Mosby, Toronto, 1984. P1230-1268.
- [5] Bowers L.D; Clin. Chem; 26,p551-556(1980)
- [6] Young D; In Effect of Preanalytical variables on Clinical Laboratory Tests, 2nd ed; AACCC Press, Washington, 1997,p4-494
- [7] Newman D.J; price C.P; Renal Function and Nitrogen Metabolites, InTietz Textbook of Clinical Chemistry, 3rd ed., Burtis C.A. and Ashwood E.R., Eds. W. B. Saunders, Philadelphia,1999, p 1204-1264.
- [8] Kaplan A., Laverna L. S., The kidney and tests of Renal Function, In Clinical Chemistry: Interpretation and Techniques, 2nd ed., Lea and Febiger, Philadelphia, 1983, p 109-142.
- [9] Operational manual of Equipment BS-300 MINDRAY MODEL AUTO ANALYSER

### AUTHORS



**First Author** – Sreedhar.Malleti is presently a researchscholar of Department of Instrument technology of Andhrauniversity,Visakhapatnam,Andhraprad esh,India.



**Second Author** – Dr.A.Bhujangarao is currently a Professor and Head of the Department of Instrument technology of Andhrauniversity,Visakhapatnam,Andhraprad esh,I ndia.He Obtained his PhD in Instrument technology from Andhra university. He had published several national and international journals. He has guided some of research scholars. He was also worked as Chairman for Board of studies for Instrumentation engineering of Andhrauniversity,visakhapatnam



**Third Author** – Dr.P.L.H.Varaprasad is currently retired Professor and Head of the Department of Instrument technology of Andhra university, Visakhapatnam, Andhraprad esh, India. He Obtained PhD in Instrument technology of Andhra university. He had published several national and international journals. He has guided some of researchscholars.he is very much interested in the area of thin film technology. He was also worked as Chairman for Board of studies for Instrumentation engineering of Andhra university.

# DESIGN OF HIGH SPEED AND LOW POWER 4T SRAM CELL

*P. Pavan Kumar<sup>1</sup>, Dr. R Ramana Reddy<sup>2</sup>, M.Lakshmi Prasanna Rani<sup>3</sup>*

Department of ECE, MVGR College of Engineering, Vizianagaram, Andhra Pradesh, India  
[panangipallipavan@gmail.com](mailto:panangipallipavan@gmail.com), [profrreddy@yahoo.co.in](mailto:profrreddy@yahoo.co.in), [prassugowtham@gmail.com](mailto:prassugowtham@gmail.com)

**Abstract:** Portable devices demand for low power dissipation. To reduce power dissipation, the subsystem in a device needs to be designed to operate at low power and also consume low power. Significant progress has been made in low power design of dynamic RAM's. Static RAM's are also critical in most VLSI based system on chip applications. Basic SRAM bit cell consists of 6T. Few designs using 4T are also available in open literature. In this paper a highly reliable, low power and high speed SRAM design is proposed and comparisons were made with 6T and basic 4T SRAM designs.

**Keywords:** Power dissipation, Dynamic RAM, Static RAM, 6T-SRAM, 4T-SRAM.

## I. INTRODUCTION

CMOS scaling has offered significant improvement in performance for the past four decades. However, as technology scaled down, standby power consumption was increased exponentially with the decrease of threshold voltage of MOSFET devices [1,2]. SRAM being one of the important sources of static power consumption demands its mere existence in most of the digital circuits. This challenge of optimizing the power consumption gives us the very need to design a new low power SRAM to enable the digital world set itself into miniature model.

## II. CONVENTIONAL 4T SRAM CELL DESIGN

4T SRAM cell is the key SRAM component storing binary information. A typical SRAM cell uses two PMOS and two NMOS transistors forming a latch and access transistors. Access transistors enable access to the cell during read and write operations and provide cell isolation during the unaccessed state an SRAM cell is designed to provide non-destructive read access, write capability and data storage (or data retention) for as long as cell is powered[2,3]. The conventional 4T-SRAM consists of both nMOS and pMOS. In general, the cell design must strike a balance between cell area, robustness, speed, leakage and yield. Power reduction is one of the most important design objectives. However, power cannot be reduced indefinitely without compromising with other parameters like cell area and speed of operation. The mainstream four-transistor (4T) CMOS SRAM cell is shown in Figure-1, four transistors (q1-q4) comprise cross-coupled CMOS inverters and two nMOS transistors q2 and q4 provide read and write access to the cell.

A 6T CMOS SRAM cell is the most popular SRAM cell due to its superior robustness, low power and low-voltage operation. It is well known that the 4T-SRAM cells have dominated the standalone SRAM market since they occupy much less cell area than 6T-SRAM cells[2,3]. However, for on-chip storage in microprocessors and other logic circuits, the 4T-SRAMs have not been used, because they need a complex process to form a load element and have poor stability at low voltage.

The conventional 4T-SRAM cell design and layout is shown in Figures 1 and 2 respectively. It consists of two nMOSFETs and two pMOSFETs for drive transistors and transfer gates, and two load elements to hold cell data. During READ/WRITE operation, a high-node level in the SRAM cell is lower than a supply voltage ( $V_{dd}$ ) by a threshold voltage of the transfer transistor, even though both bit lines are precharged at  $V_{dd}$ . This is because

transfer gates operate as source-follower circuits when the cell is selected[4]. After closing the transfer gate, current through the load element raises the high-node level to ( $V_{dd}$ ) but it takes an order of milliseconds since the current is, in most cases, 1–10pA[1]. During this transient time as well as *READ/WRITE* operation itself, this 4T-SRAM cell is very unstable against noise from peripheral circuits because of less critical charge.

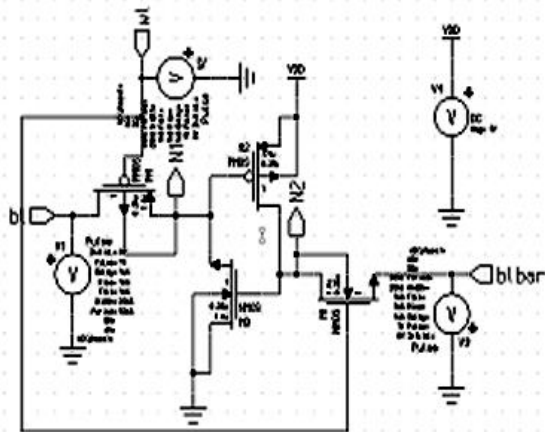


Figure 1. Conventional 4T SRAM cell

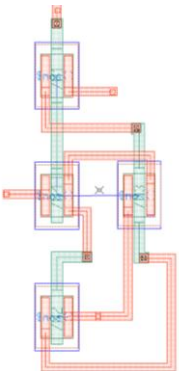


Figure 2. Layout of 4T SRAM

Although dynamic (switching) power is the dominant source of power dissipation, static (leakage) power is increasing exponentially and is projected to become severe over the next several technology generations, with some estimates as high as 50% or more of total power. The largest source of leakage power is in large array structures, of which caches and branch predictors are among the largest[5,6]. The risk of state-losing techniques is that premature deactivation may lose useful data, incurring a later induced cache miss. State-preserving techniques avoid this problem but have higher standby leakage currents.

Conventional SRAM design has the problem of large capacitive loads that must be switched when moving between active and standby mode. A new read circuit is proposed as an individual read operation will be performed and the bit lines are precharged to  $V_{DD}$ [7,8]. The read operation is initiated by enabling the word line (WL) and connecting the precharged bit lines, BL and BLB, to the internal nodes of the cell. Upon read access, the bit line voltage VBL remains at the precharge level. The complementary bit line voltage VBLB is discharged through transistors Q1 and Q3 connected in series[8,9]. Effectively, transistors Q1 and Q3 form a voltage divider whose output is now no longer at zero volts and is connected to the input of inverter Q2–Q4. Sizing of Q1 and Q3 should ensure that inverter Q2–Q4 do not switch causing a destructive read.

4T cells are as fast as 6T cells, but they do not store charge indefinitely. Rather, the charge gradually leaks away at a rate that is a function of the cell's specific design as well as the current operating temperature[5,7]. This caps the amount of leakage energy that an unused cell can dissipate. Since power and ground lines need not

stripe vertically down the array, 4T cells can have area benefits as well. 4T cells are especially applicable to on-chip structures whose data is both transient and predictive.

An attempt is made to address problems like charge leakage and large capacitive loads leading to delay and power dissipation in conventional 4T SRAM Cell design by proposing suitable modifications in the next section[6,8].

## PROPOSED 4T SRAM

The proposed 4T SRAM cell with inverter is shown in figure 3 which improves the power and stability of write operation. These cells have no connection to V<sub>dd</sub> and thus inherently provide decay functionality: values are refreshed upon access but discharge over time without use[8]. Much of on-chip storage is devoted to transient, often short lived data. Despite this, virtually all on-chip array structures use 4T static RAM cells that store data indefinitely. This makes 4T cells uniquely well-suited for predictive structures like branch predictors and BTBs where data integrity is not essential.

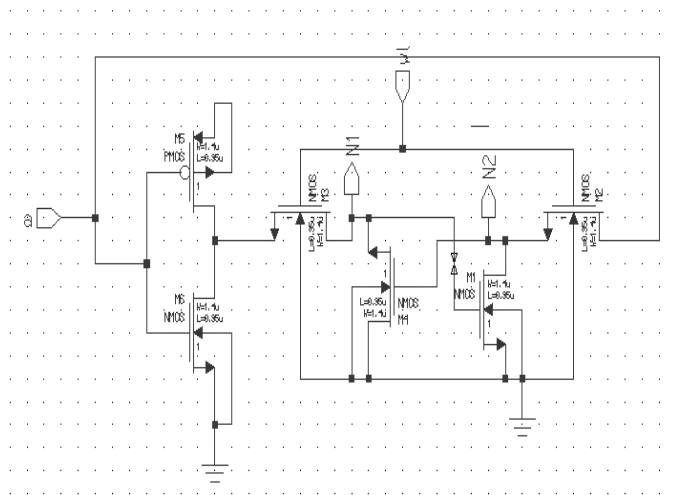


Figure 3. Proposed 4T SRAM cell using inverter

There are three premiere capacitances in SRAM cell. These capacitances include BL and BLB capacitances, word lines capacitances. BL and BLB capacitances are mainly composed drain junction capacitance of access transistor of SRAM cell. Next large capacitance in SRAM cell is word-lines capacitance and mainly composed of gate capacitance of access transistors of SRAM cell[9]. These capacitances mainly composed drain junction capacitance of access transistors of 4T SRAM cell and gate capacitances and drain junction capacitance of PMOS load transistors and NMOS drive transistors.

Locality is relevant in the SRAM design because it impacts how 4T cells are refreshed[7]. Branch predictors are typically laid out as a square, with each row having multiple neighboring predictors. In a squarified predictor, reading a row refreshes all the cells in a row because the WL is asserted. Retention time selection and locality granularity go together because large row granularity makes the apparent rate of refresh much higher. Cells that would have decayed if left alone get refreshed coincidentally by nearby active cells[4]. Thus 4T cells with short retention times may not lose data as quickly if the row size is long enough. In contrast, in a design with very fine row granularity one would opt for 4T cells with very long retention times.

Proposed 4T SRAM had been implemented and its write operation is observed with the inverter condition using one input source for both BL and BLBAR. When applying the input the BL and BLBAR will be in inverse and WL should raise either from 0 to 1 or from 1 to 0 for successful write operation.

## RESULTS

Simulation of SRAM Cell is done using Mentor Graphics Tools using 130nm technology. The output waveforms of Conventional and Proposed 4T SRAM cells are shown in Figure 4 & 5. The reliability of SRAM cell depends on the power consumed by the circuit which is the main requirement for SRAMs in portable devices.

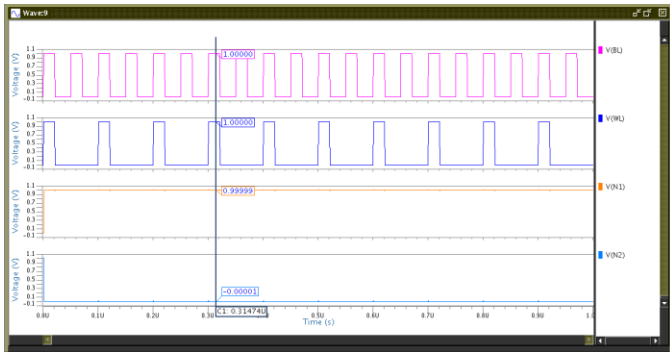


Figure 4: Waveforms of 4T Conventional SRAM

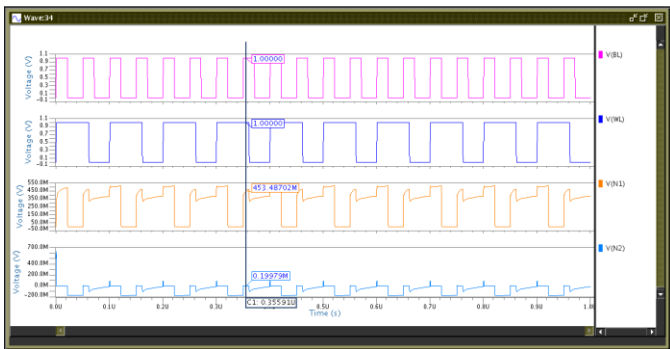


Figure 5: Waveforms of Proposed 4T SRAM

TABLE I. PERFORMANCE COMPARISON OF CONVENTIONAL & PROPOSED 4T-SRAM

Parameters	4TSRAM	Proposed 4TSRAM
Area	19.22 $\mu\text{m}^2$	26.92 $\mu\text{m}^2$
Delay	27.5ps	17.9ps
Static power dissipation	75.24nw	44.85nw
Total power dissipation	667.6 $\mu\text{w}$	459 $\mu\text{w}$

## CONCLUSION

The proposed 4T SRAM Cell is designed using nMOS transistors and an inverter to achieve high reliability and high density SRAM. The proposed SRAM cell static power dissipation is reduced by 41% and total power dissipation by 32% , delay is reduced by 36% and occupies 32.46% less area when compared with conventional 6T SRAM and 26% more area compared with conventional 4T SRAM cell. As the Proposed Model dissipates less power and has reduced delay it is useful for the design of memories in power efficient applications.



#### References

- [1] Kenji Noda, Member, IEEE, Koujiro Matsui, Koichi Takeda, and Noritsugu Nakamura "A Loadless CMOS Four-Transistor SRAM Cell in a 0.18- $\mu$ m Logic Technology" IEEE TRANSACTIONS ON ELECTRON DEVICES, VOL. 48, NO. 12, DECEMBER 2001
- [2] K. Ishibashi, K. Takasugi, K. Komi-yaji, H. Toyoshima, T. Yamanaka, A. Fukami, N. Hashimoto, N. Ohki, A. Shimizu, T. Hashimoto, T. Nagano, and T. Nishida, "A 6-ns 4-Mb CMOS SRAM with offset-voltage insensitive current sense amplifiers," IEEE J. Solid-State Circuits, vol. 30, no. 4, Apr. 1995, pp. 480–486.
- [3] Arash Azizi Mazreah, Mohammad T. Manzuri Shalmani, Hamid Barati, and Ali Barati: A Novel Four-Transistor SRAM Cell with Low Dynamic Power Consumption. International Journal of Electronics, Circuits and Systems (IJECS), Vol. 2 No. 3, pp. 144-148 (2008)
- [4] Debasis Mukherjee<sup>1</sup>, Hemanta Kr. Mondal<sup>2</sup> and B.V.R. Reddy<sup>3</sup>, Static Noise Margin Analysis of SRAM Cell for High Speed Application, IJCSI International Journal of Computer Science Issues, Vol. 7, Issue 5, September 2010.
- [5] Fdf M. Yamaoka, Y. Shinozaki, N. Maeda, Y. Shimazaki, K. Kato, S. Shimada, K. Yanagisawa, and K. Osada, "A 300-MHz, 25 A/M bit leakage on-chip SRAM module featuring process-variation immunity and low-leakage-active mode for mobile-phone application processor," in IEEE Int. Solid-State Circuits Conf. Dig. Tech. Papers, Feb. 2004, pp. 494–495.
- [6] Nakkala Suresh, Dr Vangala Padmaja, JLV Ramana Kumari " Low Voltage Low Power SRAM design based on Schmitt Trigger technique" Iosr journal of vlsi and signal processing (iosr-jvsp) volume 3, issue 5 (nov. – dec. 2013),
- [7] T. Yamanaka, T. Hashimoto, N. Ha-segawa, T. Tanaka, N. Hashimoto, A. shimizu, N. Ohki, K. Ishibashi, K. Sasaki, T. Nishida, T. Mine, E. Takeda, AND T. Nagano, "Advanced TFT SRAM cell technology using a phase-shift lithography," IEEE Trans. Electron. Devices, vol. 42, no. 7, Jul. 1995, pp. 1305–1313.
- [8] A. Kotabe, K. Osada, N. Kitai, M. Fujioka, S. Kamohara, M. Moniwa, S. Morita, and Y. Saitoh, "A Low-Power Four-Transistor SRAM Cell With a Stacked Vertical Poly-Silicon PMOS and a Dual-Word-Voltage Scheme," IEEE J. Solid-State Circuits, vol. 40, no. 4, April 2005, pp. 870-876.
- [9] K. Noda, K. Matsui, K. Imai, K. Takeda, and N. Nakamura, "A load less CMOS four-transistor SRAM cell in a 0.18- logic technology," IEEE Trans. Electron. Devices, vol. 48, no. 12, Dec. 2001, pp. 2851–2855.
- [10] G. Torrens, et al. 2008. Analysis of Radiation Hardening Techniques for 6T SRAM with Structured Layout. IEEE Int. Reliability Physics Sym

# An Analytical Study of Dissimilar Materials Joint Using Friction Welding and It's Application

Sirajuddin Elyas Khany<sup>1</sup>, S.N.Mehdi<sup>2</sup> G.M.Sayeed Ahmed<sup>3</sup>

<sup>1</sup>Associate Professor, Department of Mechanical Engg. M.J. College of Engineering &Technology, Hyderabad AP-500034.

<sup>2</sup>Professor, Department of Mechanical Engg. M.J. College of Engineering &Technology, Hyderabad AP-500034.

<sup>3</sup>Senior Assistant Professor, Department of Mechanical Engg. M.J. College of Engineering &Technology, Hyderabad AP-500034.

**Abstract-** In this research paper the effect of friction welding parameters such as rotational speed, friction time, forging pressure and friction pressure on tensile strength of a joint between SS316 and EN8 is experimentally investigated. A partial factorial design of experiment based on Taguchi analysis is conducted to obtain the response measurements. Analysis of variance ANOVA and main effects plot is used to determine the significant parameters and set the optimal level for each parameter. Based on the experimentally determined optimal parameters a confirmation experiment is conducted. These results will be useful to the industry in selecting optimal process parameters while preparing a friction welded joint of SS316 with EN-8.

EN-8 by making a friction welded joint between 1/3 of SS316 and 2/3 of EN-8, thus saving costs of manufacture of shaft. Having done so, now the challenges in welding the two dissimilar materials by friction welding and also identify the optimal process parameters in order to obtain higher strength of the joints. This work involves the experimental study on friction welding of dissimilar materials such as SS 316 and EN-8. For all the friction welding system, rotational speed, friction pressure, forging pressure and friction time are the principle controlling variables which influence the metallurgical and mechanical properties of friction welded joints. These dissimilar joint specimens thus prepared by friction welding have been studied for tensile strength.

## I. INTRODUCTION

Friction welding has been used widely in industry in joining similar and dissimilar materials efficiently because of the advantages such as material saving, low production time, elimination of filler material and production of joints as strong as parent metal, with very little heat affected zone. Different studies have been undertaken by Midling et.al {1} who have examined the properties of friction welded joints between AlSiMg(A357) alloy containing 10% Volume of Sic particles with a mean diameter of 20microns. Kreyr and Reiner{2} studied the joint strength of mechanically alloyed aluminium alloy(DispAl) containing a fine dispersion of Alumina and carbide particles. Aritoshi et al {3} compared the friction welding characteristics of Oxygen free Cu-Al joints. Cola and Baeslack {4} have examined the relationship between joining parameters and the tensile properties of 6061 alloy tubing, containing 10% volume Al<sub>2</sub>O<sub>3</sub> particles. Esslinger{5} reported the experimental studies on the effect of process parameters on strength of steel.Roder{6} studied the optimal parameters while welding high speed steel to carbon steel.Hence as the literature survey indicates that no work has been carried out in welding SS316 and EN-8 joints by friction welding process and the purpose of conducting this experimental study is to assist a pump manufacturing industry to reduce the cost of the pump shaft by replacing the expensive materials such as Inconel and SS316 with a cheaply available EN-8 to an extent of 2/3 length of the shaft. Generally the pump manufacturers use highly corrosion resistant materials such as SS316 and Inconel to manufacture a pump shaft used in corrosion and chemical environment even though the entire length of the shaft does not come in contact with the corrosive fluids. Hence an attempt has been made to replace 2/3 of expensive shaft material with cheaper material like

**Table 1: Specifications of the Material**

Material used	SS 316 & EN-8
Specifications of work piece	
Diameter of Rod	16mm
Length of Rod (SS-316)	200mm
Length of Rod (EN-8)	100mm
Total length	300mm

**Table 2: Specifications of Machine**

F.W.M/c Type	FWT-12
Max weld area	800 mm <sup>2</sup>
Min weld area	70 mm <sup>2</sup>
Max bar capacity (solid dia)	16 mm
Min bar capacity (solid dia)	10 mm
Max length of rotating piece	220mm
Max length of non rotating piece	300mm
Max forge force	120kN
Spindle speed variable	1000-2000 RPM
Spindle bore depth from collet face	200mm
Slide stroke	350mm
Total connected wattage	30KVA
Supply voltage	400V/50HZ
Spindle drive	15KW
Control voltage	24VDC

**Table 3: Friction welding factors varied in 3 levels**

Levels Factors	High	Medium	Low
Speed (RPM)	1580	1250	980
Forging Pressure (Bar)	28	25	22

Cooling method	Air	Water	Oil
----------------	-----	-------	-----

## II. DESIGN OF EXPERIMENT

In this research work the type Taguchi Design selected is a 3 Level 3factor design represented as Taguchi Orthogonal Array Design, L9 (3<sup>3</sup>), where number of Factors is 3 and number of Runs is 9 and number of Levels of each factor is 3. Taguchi Orthogonal Array Design selected to carryout this experiment is as given in Table 2. The control factors considered for TAGUCHI design matrix are rotational speed, forging pressure, cooling method and the response variables is tensile strength. The experiment conducted to identify the optimal parameters for maximum tensile strength of the joint. 9 orthogonal arrays for tensile test is considered with friction-welding factors varied in 3 levels

**Table 4: Taguchi Orthogonal Array Design L9 (3\*\*3)**

S.NO	A	B	C
1	1	1	1
2	1	2	2
3	1	3	3
4	2	1	2
5	2	2	3
6	2	3	1
7	3	1	3
8	3	2	1
9	3	3	2

The above table 2 shows the Orthogonal Array matrix Of L9 (3\*\*3). In this the First row indicates the number of factors which will be tested which are 3 in this case. The First column shows the number of Experiments that must be completed, in this case being 9. The other columns underneath show the levels of each factor, in this case 3 i.e. (High-3, Medium-2 and Low-1). INPUT Variables for 9 Runs, 3 Levels and 3 Factors.

**Table 5: Factors/ Input variables for 9 Runs, 3 Levels and 3 Factors**

Runs	Speed	Friction pressure	Cooling Method
1	980	22	Air
2	980	25	Water
3	980	28	Oil
4	1250	22	Water
5	1250	25	Oil
6	1250	28	Air
7	1580	22	Oil
8			
9			



Fig.1: Specimens of joint between SS316 and EN-8 as per L<sub>9</sub>3<sup>3</sup>

## III. EXPERIMENTAL PROCEDURE

The test material is comprised of 16 mm diameter rods of SS 316 and EN-8. According to Taguchi design, the 9 specimens of 16mm diameter and 300 mm length were prepared and facing operation was done for all specimens on Lathe machine. The friction welding setup is prepared according to the selected factor levels as indicated in orthogonal matrix before performing welding. Friction welding was performed using a Continuous drive Friction welding machine setup where one of the work piece is attached to a rotating motor drive while the other is fixed in an axial motion system and one work piece is rotated at constant speed as setup on the machine. The Two work pieces are brought together under pressure, after a red hot state is reached at the interface, the rotating power is disengaged and the forging pressure is applied. When the rotating piece stops, the weld is completed. This process can be accurately controlled when speed, pressure and time are closely regulated. These weld joints of SS 316 and EN-8 are taken for Tensile strength testing on a UTM.

**Table 6: Tensile Strength Test results**

RUNS	Tensile Strength, KN/mm <sup>2</sup>
	0.0895
2	0.2225
3	0.1919
4	0.0686
5	0.1996
6	0.2735
7	0.2516
8	0.2608
9	0.2837

**Table 7: Response Table for S/N Ratio of Tensile Strength Test**

Level	Speed	Forging pressure	Cooling Method
1	-16.12	-18.74	-14.63
2	-16.18	-12.91	-15.76
3	-11.53	-12.18	-13.44
Delta	4.64	6.56	2.32
Rank	2	1	3

The response table above shows the average of each response characteristic (s/n ratio) for each level of each factor. The tables include ranks based on Delta statistics, which compare the relative magnitude of effects. The Delta statistic is the highest minus the lowest average for each factor. Minitab assigns ranks based on Delta values. Rank 1 to the highest Delta value, rank 2 to the second highest, and so on. In this Experiment the ranks indicate that Forging Pressure has the greatest influence on the S/N ratio, followed by Rotational speed then Cooling method. Our goal is to increase the Tensile strength of friction welded joint for SS 316 and EN-8 material. Since by determining the

optimal factor levels that produce the highest mean. The level averages in the response table.5. show that means were maximized when the rotational speed was 1580 R.P.M and forging pressure was 28 bars and cooling method is Oil. Based on these results for maximized Tensile Strength the control

factors should be set at the levels indicated below in the S/N ratio plot. It has been observed that with Oil Quenching the optimized parameters are 28 Bar as Forging Pressure and Rotational Speed as 1500RPM

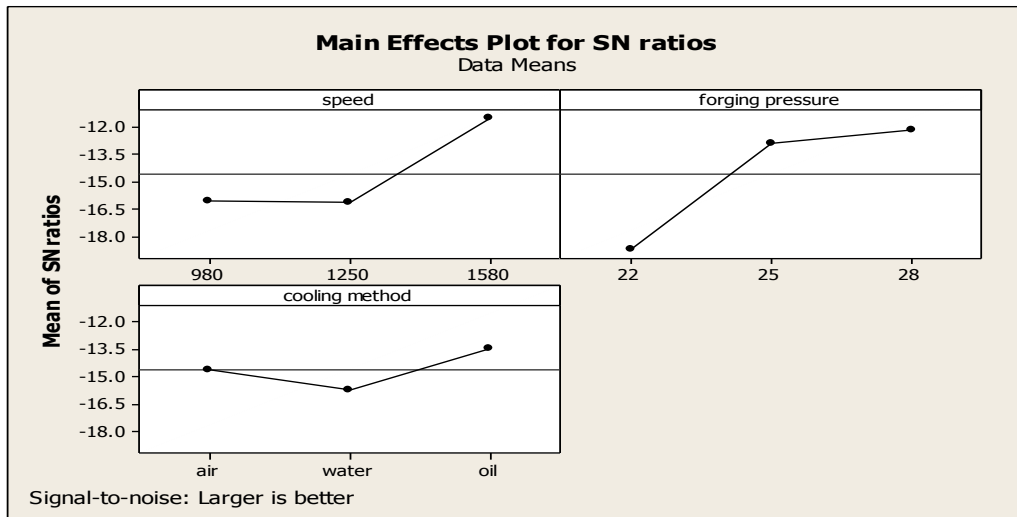


Fig 2: Main effect plot for S/N ratios

Table 8: Analysis of Variance for Tensile Strength test data

Source	DF	Seq SS	Adj SS	Adj MS	F	P
Speed	2	0.0016837	0.0016837	0.008418	1.79	0.358
Friction Pressure	2	0.021579	0.021579	0.010790	2.30	0.303
Cooling Method	2	0.000826	0.000826	0.000413	0.09	0.919
Error	2	0.009380	0.009380	0.004690		
Total	8	0.048622				

S= 0.0684832 R-Sq = 80.71% R-Sq(adj) = 22.83 %

Predicted Values:

S/N Ratio = -7.93544

Mean = 0.320167

The confirmation experiment is the final step in the first iteration of the design of the experiment process. The purpose of the confirmation experiment is to validate the conclusions drawn during the analysis phase. The confirmation experiment is performed by conducting a test with a the optimal combination of the factor levels previously evaluated. In this study, after determining the optimum conditions and predicting the response under these conditions, a new experiment was designed and conducted with the optimum levels of the welding parameters. The final step is to predict and verify the improvement of the

performance characteristic. The predicted S/N ratio  $\eta$  using the optimal levels of the welding parameters can be calculated as  $\eta = \eta_m + \sum_{j=1}^k (\eta_j - \eta_m)$ ;  $j = 1, 2, 3, \dots, k$  where  $\eta_m$  is total mean of S/N ratio,  $\eta_j$  is the mean of S/N ratio at the optimal level, and  $j$  is the number of main welding parameters that significantly affect the performance. The results of experimental confirmation using optimal welding parameters and comparison of the predicted tensile strength with the actual tensile strength using the optimal welding parameter are shown in table. The summary statistics for the S/N ratio  $\eta$  (dB) is given by  $\eta = -10 \log_{10} (1/N \sum 1/y^2)$ , Improvement formula  $Y2 - Y1 / Y2 \times 100$

Table 9: Improvement in S/N ratio

Performance measure	optimal Process Parameter settings	Predicted values	Confirmation experiment values	Improvement in s/n ratio and tensile strength in %
Tensile Strength(kN)	0.20463	0.320167	0.31831	35.71

S/N (dB)	-13.78061	-7.93544	-9.94295	-38.59
----------	-----------	----------	----------	--------

#### IV. CONCLUSION

Mechanical behavior of the friction welded joint for SS 316 and En-8 is studied by the Taguchi design of experiment and it is observed that the friction processed joint exhibited good strength and joint strength increased with increase in friction pressure and forging pressure at high and moderate levels of rotational speeds and the optimal value of process variables for a higher tensile strength from the Taguchi design is 1580 R.P.M, 28 bar forging pressure and oil quenching. A study of the regression analysis for tensile strength was also studied (presented else where) and the correlation between experimental values and predicted values of tensile strength was established with a correlation co-efficient of 0.971 . The main effect for SN ratio and relation between parameters by employing ANOVA was studied for Tensile strength of the joint. and it was observed that at all levels of variables, there is an interaction between control factors and the response variable and the contribution of the interaction between control factors is negligible. And from the main affects plot the level of factors that have more effect on the Tensile Strength was noted. From the Taguchi design of experiment it is observed that the factor that has more effect on the Tensile Strength is forging pressure then speed and finally cooling method. Thus it can be concluded that the joint between the dissimilar materials SS316 and EN-8 can be successfully carried out and the process can be optimized. This enables a pump manufacturing industry to replace 2/3 of expensive material of the shaft with cheaper material EN-8 and thus save huge amounts.

#### AUTHORS

**First Author** – Sirajuddin Elyas Khany, Associate Professor, Department of Mechanical Engg. M.J. College of Engineering &Technology, Hyderabad AP-500034. Email: sirajkhany@yahoo.co.in

**Second Author** – S.N.Mehdi, Professor, Department of Mechanical Engg. M.J. College of Engineering &Technology, Hyderabad AP-500034. Email: syednawazishmehdi@mjcollege.ac.in

**Third Author** – G.M.Sayeed Ahmed, Senior Assistant Professor, Department of Mechanical Engg. M.J. College of Engineering &Technology, Hyderabad AP-500034. Email: drgmsa786@gmail.com

- [1] O. T. MIDLING, O. GRONG and M. CAMPING, in Proceedings of the 12th International Symposium On Metallurgy and Materials Science, Riso, edited by N. Hansen (Riso National Laboratory, Denmark, 1991) PP. 529-534.
- [2] H. KREYE and G. REINER, in Proceedings of the ASM Conference on Trends in Welding Research, Gatlinburg, TN, May 1986 edited by S. David and J. Vitek (ASM International Metals Park, 1986) PP. 728-731.
- [3] M. ARITOSHI, K. OKITA, T. ENDO, K. IKEUCHI and F. MATSUDA, Japan. Welding Society. 8 (1977) 50.
- [4] M. J. COLA, M.A.Sc thesis, Ohio State University, OH (1992).
- [5] ESSLINGER, J. Proceedings of the 10th World conference of titanium (Ed. G. LUTJERING) Wiley-VCH, WEINHEIM, Germany, 2003.
- [6] RODER O., Hem D., LUTJERING G. Proceedings of the 10th World conference of titanium (Ed. G. LUTJERING) Wiley-VCH, WEINHEIM, Germany, 2003.
- [7] M. J. COLA and W. A. BAESLACK, in Proceedings of the 3rd International. SAMPE Conference, Toronto Oct., 1992, edited by D. H. Froes, W. Wallace, R. A. Cull, and E. Struckholt, Vol. 3, PP 424-438.
- [8] Aeronautics for Europe Office for Official Publications of the European Communities, 2000.
- [9] BARREDA J.L., SANTAMARÍA F., AZPIROZ X., IRISARRI A.M. Y VARONA J.M. "Electron beam welded high thickness Ti6Al4V plates using filler metal of similar and different composition to the base plate". Vacuum 62 (2-3), 2001.PP 143-150
- [10] EIZAGUIRRE I., BARREDA J.L., AZPIROZ X., SANTAMARIA F. Y IRISARRI A.M. "Fracture toughness of the weldments of thick plates of two titanium alloys". Titanium 99, Proceedings of the 9th World Conference on Titanium: Saint Petersburg, (1999), PP. 1734-1740.



# Gripper Actuator Using Shape Memory Alloy Spring

Sundara sathiyar KS, Vikram singh I, Rajesh V

**Abstract-** This paper describes a new technique of gripper actuator using shape memory alloy spring has been fabricated .By applying electric power to the shape memory alloy spring i.e by being safely heating it has an ability to retain their original shape from fabricated shape i.e in austenite phase. When the power supply is off, Steel spring which compress the shape memory alloy spring to its fabricated shape. Thus Experimental results shows the rack and pinion to extract and retract in control motion would actuate the gripper to pick and place an object.

**Index Terms-** shape memory alloy spring, steel spring, gripper, rack and pinion.

## I. INTRODUCTION

Most standard and available Shape memory alloy (SMA) is Ni-Ti. composition of nickel and titanium materials.SMA are in one way and two actuations. One way actuator which is used in our experiment can contract when heating(austenite phase). Two way actuator can be stretched easily when cooling (martensite phase), but contract forcibly when heating.

NOTE:

1. Based on linear-elastic deformation parallel to length of the wire
2. Activation current and Contraction time can be adjusted considerably based on environmental considerations.

The table below shows typical performance characteristics based on set parameters.

PERFORMANCE CHARACTERISTIC				
Wire diameter (inches)	Resistance (ohm/inches)	Maximum Pull force (g)	Applied current at room temperture (mA)	Contraction time (seconds)
0.015	0.2	2000	2750	1
0.020	0.16	3500	4000	1

SMA advantages include mechanical simplicity, high power to weight ratio , small size, and clean, silent, spark-free operation. And some serious disadvantages are inefficiency , hysteresis and slow speed.

Among the various types of gripper, here it involves intense use of rack and pinion gears, because it is a type of linear actuator.

Mild steel spring has low carbon content It yields high strength and compress certain weight depends on its thickness and have the capability to compress. But the superelasticity and shape memory behaviour are not normally exhibited by steels.

## II. EXPERIMENTAL SET UP



[ Modeled in unigraphics (NX9)]

This model shows the proposed view of gripper actuator using shape memory alloy spring. shape memory alloy used in this experiment most useful one for the mechanical simplicity and weight reduction and free spark operation. The table shown below are needed components with specified materials for the proposed model.

COMPONENT	MATERIAL
Gripper	Polypropylene(white)
Connecting rod	Aluminium
Pinion	Aluminium
Spring	Mild steel
Rubber	Hard black
Wire	Shape memory alloy

Materials which used as per the above table is because of weight reduction in this experiment. Therefore the maximum pull force of shape alloy directly applicable(pick and place) on an object.

## III. CALCULATION

This experiment has a calculation for spring, rack and pinion.

Shape memory alloy spring free length and compression length are calculated as shown in figure with respected formulae.

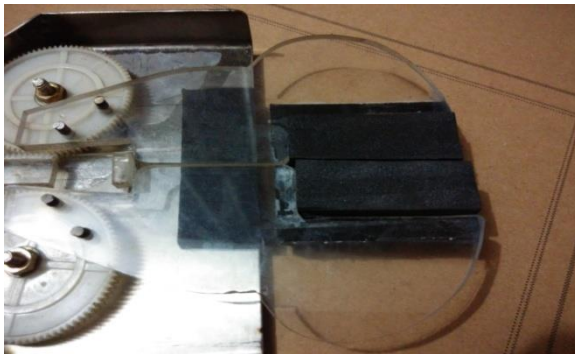
DIMENSIONAL PARAMETERS		
Parameter	Symbol	Value
Wire diameter	d	0.5mm
Free length	$L_f$	60mm
SPRING MATERIAL & STRESS RELATED PARAMETERS		
Parameter	Symbol	Value
Elastic modulus	E	83Gpa
Poisson's ratio	i	0.3

Also the compression of steel spring has calculated as shown in figure.

PARAMETERS	FORMULA	RESULT
pitch	$P = 3.1416/p$	6.28mm
Outer diameter	$OD = (z+2)*m$	38mm
Module	$m = p / \pi = Dp / z$	2
Number of teeth	$Z = dp/m$	17
clearance	$D/d$	0.33mm
addendum	$a = 1/DP$	2mm
dedendum	$d = hw - a$	2.33mm
pitch diameter	$Dp = z*m$	34mm

#### IV. FABRICATION OF GRIPPER

Acrylic sheet of 5×150mm is purchased and the length of 90mm is been cut with required dimensions using hack saw machining tool. Hence parts has been cut and fixed to the pinion where this is used to make the gripping section of the actuator.



**Fabricated Gripper**

A elastic material used at the gripping portion of the actuator where it is cut according to required dimensions and it is attached with a glue called anabond. Anabond is a glue that mostly used to fixing ceramic materials, metals etc.

#### V. FABRICATION OF SPRING

To achieve optimized properties, materials with 30-40% retained cold work before heat treatment should be used. Superelastic Nitinol materials are typically heat treated in the vicinity of 500°C. Lower temperatures in the range between 350°C and 450°C are also suitable for shape memory alloys.



**Fabricated Spring**

The purchased shape memory alloy wire (nitinol) is then fabricated to spring by using a winding tool and then heated to 500°C in a furnace then suddenly cooling it with water hence the fabricated shape becomes the original shape. By changing its shape without heating and heating the nitinol or passing the electricity at 6 to 12V the alloy changes to its original shape.

#### VI. CONCLUSION

A mechanical gripper has been designed and fabricated. By use of shape memory alloy spring, the mechanical gripper is able to pick an object of small size of 98mm diameter and weight less than 200g. The shape memory alloy spring is a simple design which reduces the size, cost and use of electronic equipments. This mechanical gripper can be automatically activated by supply of heat and also it can be used in high temperature environments such as robotic application, chemical industries, laboratories, nuclear power plant etc.

#### REFERENCES

- [1] Ari Leppäniemi, Shape memory alloys applications and commercial aspects [Email: ari.leppaniemi@tut.fi]
- [2] C. Mavroidis, Development of Advanced Actuators Using Shape Memory Alloys and Electrorheological Fluids, [march 2002]
- [3] Stoeckel, Shape Memory Actuators for Automotive Applications [1990]
- [4] Sonia degeratu, Horia O. manolea, Nicu G. bizdoacă, Gheorghe manolea, Anca petrișor, Characterization and Design of a Shape Memory Alloy wire actuator [oct 2009].
- [5] Weimin Huang P, Shape Memory Alloys and their Application to Actuators for Deployable Structures, [1998]
- [6] Improving the speed of SMA actuators by faster electrical heating. [Dept. Systems Engineering Australian National University Canberra ACT 0200, Australia roy@syseng.anu.edu.au http://www.syseng.anu.edu.au/roy/ 2 Dept. Systems Engineering Australian National University yee.teh@rsise.anu.edu.au]
- [7] Jose R. Santiago anadon, Large force shape memory alloy linear actuator [2002]
- [8] Autossplice innovative interconnections (authorized distributors kensington electronics)

#### AUTHORS

**First Author** – Sundara sathiyam KS, (sundarasathiyam@gmail.com)

**Second Author** – Vikram singh I, (vimalsingh001@live.com)

**Third Author** – Rajesh V, (rajeshvpsg@gmail.com).

# Stock Price Volatility and Dividend Policy in Pakistan

Muhammad Abrar-ul-haq\*, Kashif Akram\*\*, Muhammad Imdad Ullah\*\*

\*P.hD Scholar, School of Economics, Finance and Banking, Universiti Utara Malaysia

\*\* P.hD Scholar, School of Business and Management, Universiti Utara Malaysia

\*\*\* P.hD Scholar, School of Business and Management, Universiti Utara Malaysia

**Abstract-** The purpose of this study is to test impact of dividend policy on stock price volatility in Pakistan. The study had been carried out a stratified sampling containing companies in their respective sectors with respect to market capitalization, listed in KSE. Time series data was selected from year 2001-2014. Descriptive statistics, correlation and regression models were used to perform the data analysis. According to the findings of the regression all results were not significant. This means that dividend policy had no impact on stock price volatility in Pakistan.

**Index Terms-** Earnings per share, Stock exchanges, Dividends

## I. INTRODUCTION

Corporate dividend policy is baffling and one of the puzzles in corporate finance. Issues concerning dividend decisions and stock price volatility have now engrossed the attention of financial analysts and economists from all over the world to establish relationship between these parameters. The degree to which the firm's dividend policy affects its share price is very important not only for corporate officials but also for new investors and for economists, who are seeking to figure out the operations of capital market.

The fore most question is that, why companies give dividends when these are taxed more heavily than capital gains has puzzled academics for several years?. Different researchers have diverse opinions about this query. The debate was first initiated by Modigliani and Miller (1958) who provided the basis of modern thinking on capital structure. According to MM, in the absence of taxes, bankruptcy costs, agency costs, and asymmetric information, and in efficient market, firm's stock price volatility only depends on its earning ability and firm's corporate structure is immaterial. However, MM's theory could only be legitimate if market would be efficient and share holders have all the information concerning firm's financial conditions. But companies only used to announce positive information and retained negative information to them until regulations or financial constraints forced them to unveil it because they wanted to satisfy their shareholders that company was performing very well and they have a secured investment (Bhattacharya, 1979). Allen & Rachim (1996) conducted a study on the impact of payout ratios and dividend yield on stock price changes and found that dividend payout ratio was significantly positively correlated but dividend yield has not correlated with stock price volatility. However, a study contradicted the results of Allen & Rachim's study and evidence the significant relationship among dividend yield and payout ratio with stock price changes.

Moreover Nishat and Irfan (2006) "suggest to employ subsequent control variables in testing the significance of the relationship between dividend yield and price volatility: operating earnings, size of the firm, level of debt financing, payout ratio and level of growth. These variables have a clear impact on stock returns but also impact on dividend yield". All were identified and studied as independent variables. According to previous studies it has been proved that earning volatility has positive effect on price volatility. This means that if earning volatility of the firm increased price volatility also increased and vice versa (Nishat and Irfan, 2006).

Size of a firm and leverage can also affect volatility. A promising link between size of the firm and volatility had been observed. Institutions usually preferred to conduct their research activities and investment policies on larger listed companies as compared to small companies because small companies are less diversified than larger ones. The market in the stocks of small listed firms could be perhaps less informed, more illiquid, and as a consequence subject to greater price volatility (Nishat and Irfan, 2006). Furthermore, they showed that those firms which used high debts in their capital structures paid low dividends (Nishat and Irfan, 2006).

Nishat and Irfan (2006) stated that "dividend payout policy could be inversely linked to asset growth so its effect was also valuable to determine. It is also possible that systematic differences in market conditions, cost structures, regulatory restrictions etc., might lead to differences in dividend policy. These also have impact on price volatility".

Although Nishat & Irfan (Unpublished) and Asghar et al, (2011) have "pioneered investigations pertaining to dividend policy and stock price volatility in Pakistan, yet this is a start and a lot is still to be done". Hence it is very important to explore this area further.

## II. SIGNIFICANCE & PURPOSE OF STUDY

The effect of a firm's dividend policy on the current price of its shares is a matter of considerable importance, not only to management, who must set the policy, but also to investors planning portfolios and to economists seeking to understand and appraise the functioning of the capital markets.

This poses the question, to what extent, if any, does dividend policy impact on firm value and therefore the price of a firm's shares?

Irfan and Nishat argued that "Karachi Stock Exchange (KSE) is a vital up-coming market of the region among the developing countries. KSE is termed as high-risk; high return market where investors seek high-risk premiums. Some studies

have attempted to investigate task of dividend yield and payout ratio in affecting the share prices. It is important to study the impact of dividend policy and stock price risk in the Pakistani context after the introduction of reforms during 1990s, which emphasized more towards openness to foreign investors and competition, led to increase volatility in the market and has reduced the responsiveness of share price volatility to fundamental factors. Reforms in Pakistan in general and specific to dividend policy are; tax sealing on cash dividend, exemption of right and bonus shares from tax, pattern shifting from cash to share dividend and government policy of easing restrictions on transfer of market profits etc”.

KSE is not performing well as its performance is bound to the performance of listed companies and number of investments in stocks of these companies. Currently both macro and micro economic conditions of Pakistan are not good and due to these conditions industries are not performing well and investors are less attractive towards investments in Pakistani companies. Through this research, the researcher is giving information not only to shareholders or investors but also to the business holders that what are the key factors that results in bringing volatility to share prices so that they try to control those factors and bring stability in prices.

Dividend policy measures are one of the most fundamental factors which can affect the entire makeup of the organization and also managers are very careful in dividend policy decisions. Previous research work is still unable to wrap up the connection between dividend policy measures and stock returns and stated that many other accounting variables also affect dividend policy as well as stock return (Ahmad, & Ullah, 2011). Earlier researches have made a lot of enhancements in understanding the behavior of developed and developing economies stock market returns to dividend policy because dividend policy and stock returns are one of readily available tools for the investors in making investment decision (Irfan and Nishat, 2006). This study is important because the aim of this study is to contribute in, somehow, filling the literature gap by controlling other variables as earning volatility, size of firm and growth in assets; to clarify the relationship of dividend yield and dividend payout ratio with stock price volatility. The main objective of the study is to provide knowledge base to the management, investors and financial institutions of developing economies to analyze the relationship between dividend policy measures and stock returns. And more specifically find out:

- The relationship between dividend yield and stock price volatility.
- The relationship between dividend payout ratio and price volatility.
- Dividend policy measures i.e. dividend yield and payout ratio on share price changes in the long run.

### III. LITERATURE REVIEW

Asghar, Shah, Hamid, and Suleman (2011); Nishat and Irfan (2006); Rashid and Anisur Rahman (2008) conducted research on dividend policy and stock price volatility. Though their studies covered many aspects and showed significant results yet their studies’ results were not compatible with the markets of

developed economies. Their study variables were in accordance with developing economies but still it was not true in some parameters regarding to the case in Pakistani equity market. Those parameters might be volatility in prices even at same day etc. Moreover, it lacked in reflecting true firm performance because data selected from company’s annual reports might not reflect the true picture of the firm.

Akdeniz, Salih, & Tulung Ok (2006); Khan, Burton & Power (2010) studies were very comprehensive as for as data collection is concerned but results were weakened due to weak form of efficiency in Pakistani market as past dividends influenced current dividend levels and company’s officials in Pakistan always hesitated to announce dividend cuts. Furthermore assumptions about the market efficiency were not correct because stock prices under weak form of efficiency were affected by herd mentality and inexperience investors.

The strength of Hussainey, Mgbame & Mgbame (2011) study was they used different theories in their literature in support of variables but results showed no difference if earning volatility was considered or not which is not possible because in reality earning volatility has direct and positive impact dividend payout ratio and that ultimately impact price volatility as the higher will be the dividend payout ratio, the less will be the price volatility.

Stacescu, (2004) examined dividend policies of Switzerland very comprehensively but he focused on one aspect that company were paying dividends in increasing trends but did not focus on possibilities of dividend cuts at time when the managers' reputation would be suffering and if one assumed that managers cared enough about this damages even then explanation should be given for both earnings competency of dividends and the informational content of dividend variability.

Amidu & Abor, 2006; Renneboog & Trojanowski, 2007; Twaijry 2007 studied payout ratios with different variables. All studies lack facts that what determined the decisions to pay or not to pay dividends in listed firms? What factors determined dividend payout ratio in unquoted firms? And what determine the dividend policy decisions of unquoted companies? They also over looked the fact that growing companies retained a large portion of their income and paid lesser dividends to shareholders. These studies didn’t consider factors that might examine to what extent dividend strategy can be affected by culture, economic status, and commercial environment. On the other hand, investors’ views concerning their preferences about dividends should also be surveyed which might assist company’s corporate governance in establishing good dividend plans.

Adjasi, (2009); Nazir, Nawaz, Anwar & Ahmed, (2010); Asamoah, (2010); Akbar & Baig, (2010) would not incorporate the impact of industrial output volatility and its effect on stock-price volatility. Furthermore, they conducted research with respect to one frontier but other frontiers and emerging markets should also be considered during this research.

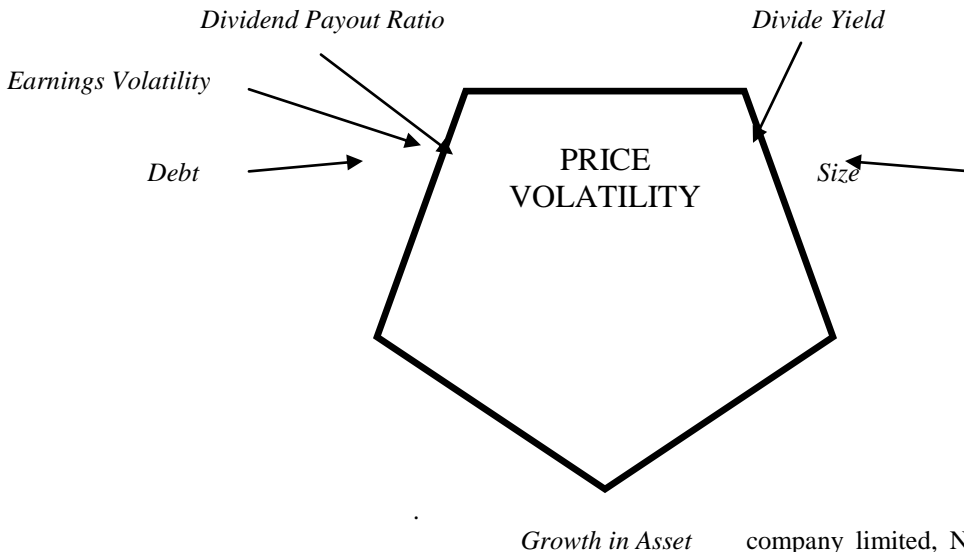
Khan, Burton & Power, (2011) took 600-plus firms listed on the KSE, were interviewed and only in a few cases were these taped. Nevertheless, the discussion purposely concentrated on those issues where an agreement emerged in order to provide generalizability. In terms of the lack of taping, in each case, the author made detailed notes during and immediately after these discussion but ultimately to remember 100% accurate knowledge



of these discussion might not possible. Finally, to acquire detailed and trustworthy evidence of the ownership structure of

the interviewed firms wasn't possible as firms were reluctant to give information about their organizational structure.

**Theoretical/Conceptual Framework**



**IV. METHODOLOGY**

Cross sectional data is used in the present study. Population frame consists of non-financial major sectors including Food, Textile, Oil and Gas, Construction and Materials, Fixed line Telecommunication and Tobacco listed on KSE-100 index. A stratified random sample of 11 non-financial, listed firms on KSE-100 index for the years 2001 and 2014 has been taken. The sample include lucky cement, Fuji fertilizers, Fuji cement, Karachi Electric Supply company, PTCL, Pakistan tobacco

company limited, Nishat mills, Al-Abbas sugars, Sui-Northern gas, D.G. Khan Cement and Attack petroleum. The study is based on secondary source of data: annual data of sample firms is collected through various sources i.e. "Balance Sheet Analysis" published by "State Bank of Pakistan" and, companies' annual reports and daily stock price data is collected from Business Recorder's and KSE's website and then converted it on annual basis. The unit of analysis is the major entity that is being analyzed in the study. This study's unit of analysis consists of non-financial, listed companies at Karachi stock exchange.

**Table 1: Operational Definition of Variables**

Variables	Operational Definitions
PV (Price Volatility)	3 The annual range of stock prices will be divided by the average of the high and low stock prices and then raised to the second power.
DY (Dividend Yield)	This variable will be calculated by summing up all the annual cash dividends paid to common stock holders divided by the average market value of the stock in a year.
EV (Earning Volatility)	4 The standard deviation of the ratio of company's operating earnings before interest and tax (EBIT) to total assets will be taken.
POR (Payout Ratio)	The ratio of company's total dividends to total earnings will be calculated. To do so total dividends and entire cumulative earnings are calculated for each year.
SZ (Size)	Firm size will be calculated as the natural logarithm of market value of equity at the beginning of the year.
ASg (Growth in Assets)	The yearly growth rate will be estimated by taking the ratio of the change in total assets in a year. Then the ratio was averaged over the years.
DA (Long-term Debt)	5 The ratio of the sum of all the long-term debt (debt with maturity more than a year) to total assets is taken. An average is taken over all available years.



**Model Specifications**

The actual dependent variable price volatility was regressed resistant to the two main separate variables, dividend yield and payout ratio. This provides some sort of crude test in the relationship between share price volatility and dividend policy using the regression equation in Model 1.

$$P\text{-Vol} = \alpha 1 + \alpha 2D\text{-yield}_i + \alpha 3Payout_i + \mu_i$$

The close relationship between dividend yield and dividend payout percentage may pose a smaller problem as there are a number of factors that will influence both dividend coverage and price volatility. For you to limit these complications, the control variables mentioned above previously earlier were included in the analysis. The dependent adjustable was regressed against the

two independent variables as well as the control variables using the following regression equation. (Model 2).

$$P\text{-Vol} = \alpha 1 + \alpha 2D\text{-yield}_i + \alpha 3Payout_i + \alpha 4Size_i + \alpha 5Earnings_i + \alpha 6Growth_i + \alpha 6Debt_i + \mu_i$$

V. RESULTS AND DISCUSSION

The mean value of price volatility (PV) is 0.36 with a 0.75 standard deviation stated in table 1, which means that it remained high volatile during this session. Among the independent variables the mean of earning volatility remained 0.24with 0.07 standard deviation which indicates very little volatility

**Table 2: Descriptive Statistics**

Variable	Mean	Std. Deviation
Price volatility	0.36	0.75
Earning volatility	0.24	0.07
Size	.22	.56
Dividend yield	91.97	42.67
Leverage	0.08	0.01
Growth	0.26	0.14
Payout ratio	0.54	0.08

Dividend yield has the highest mean and standard deviation among all the variables ( $M=91.97$  &  $SD= 42.67$ ). While mean and standard deviation of dividend payout remained is 0.54 and 0.08 respectively. On the other hand the mean and standard

deviation of growth in assets is 0.26 and 0.14 respectively. Last variable in the proposed regression model is firm Size having mean value of 0.22 and standard deviation of 0.56. The correlation results are presented in table 2.

**Table 3: Correlation Matrix**

Variables	Price volatility	Dividend yield	Payout ratio	Earning volatility	Size	Leverage
Dividend yield	-0.31					
Payout ratio	0.71	0.07				
Earning volatility	0.53	-0.78	0.49			
Size	-0.24	-0.20	-0.02	0.05		
Leverage	0.62	-0.84	0.30	.90*	-0.24	
Growth	-0.10	-0.48	-0.75	-0.13	-0.01	0.18

Correlation is significant at 0.05 level (two tailed)

Table 2 shows the correlation between all variables. The strongest correlation exist between earning volatility and leverage ( $r=.90^*$ ) which is also significant at .05, and it indicates both multi-collinearity exists between EV and L as both variables are independent. Dividend yield and leverage are also shows strong but negative correlation ( $r=-.84$ ) which means that with the increase of one variable, other variable will decrease. Moreover, dividend yield and earning volatility are also strongly negatively correlated ( $r=-.78$ ) Earning Volatility and dividend yield shows that companies with volatile earnings pay low dividends as during analysis many companies in the years of loss

usually don't pay dividends which contradicts with the results of Nazir et al' (2010) . Price volatility and payout ratios also shows strong correlation ( $r=-.71$ ) which means that with the increase in payout ratio cause decrease in price volatility. All the remaining variables are indicating weak or medium correlation with each other. As all these results are insignificant so Ho has been accepted. Correlation results of the study are different from results of Nishat and Irfan (unpublished); Nazir et al, (2010). This may be because economic conditions during their study period are much better as compared to today's situation. Moreover Nishat and Irfan, (2006) took 20 years time period and

Nazir et al, (2010) took 73 companies so this may be the reason behind variability of results as present study takes only 5 year time period from 2006-2010 and 11 companies due to time constraint.

**Table 4: Econometric Analysis of Model 1.**

Variable	Coefficient		$\beta$	T- Value	Sig
	B	Standard Error			
Constant	-2.77	2.23		-1.24	0.33
DY	-0.01	0.01	-0.35	-0.83	0.49
DP	6.78	3.91	0.73	1.73	0.22

*R Square = .63, R Adjusted R Square = .27*  
*F = 1.75 Significance = .36*

The value of  $R^2$  shows that the independent variable causes 63% variability in dependent variable which means that independent variables have strong impact on dependent variable (See also; Asghar, et al.: 2011). The value of adjusted  $R^2$  shows that these results cannot be generalized because both  $R^2$  and adjusted  $R^2$  values are not same or near to same. The  $\beta$  tells more than this, it indicated that if one standard deviation predictor variable changes, it effects the dependent variable also in standard deviations. In this particular table, if the DY would

increase by one unit then the PV would increase by  $(-0.35 \times 0.75 = -0.26)$  which shows that with the increase in DY, PV will decrease. Furthermore, if the DP would increase by one unit then the PY would increase by  $(0.73 \times 0.75 = .55)$  which shows that with the increase in DY, PV will also increase. The value of t test indicates that the predictor is making a significant contribution to the model or not. This particular table shows that t value is non-significant with means that independent variables are not significantly predicting the dependent variable.

**Table 5: Hierarchical Multiple regression analysis of Model 2.**

Step	Variables	$\beta$	Std. Error	$\beta$	t	Sig.	95% Confidence Interval for $\beta$	
							Lower Bound	Upper Bound
1	(Constant)	-0.26	2.20		-0.12	0.92	-9.72	9.20
	Earning volatility	5.84	6.07	0.55	0.96	0.44	-20.29	31.97
	Size	0.00	0.00	-0.27	-0.48	0.68	0.00	0.00
2	(Constant)	-1.03	6.27		-0.16	0.90	-80.68	78.61
	Earning volatility	7.39	13.88	0.69	0.53	0.69	-168.97	183.75
	Size	0.00	0.00	-0.24	-0.29	0.82	0.00	0.00
	Dividend yield	0.00	0.02	0.19	0.14	0.91	-0.30	0.30
1	(Constant)	-2.70	2.77		-0.98	0.43	-14.62	9.22
	Leverage	40.27	33.08	0.66	1.22	0.35	-102.07	182.62
	Growth	-1.15	2.91	-0.21	-0.40	0.73	-13.66	11.36
2	(Constant)	-7.54	10.28		-0.73	0.60	-138.16	123.08
	Leverage	77.79	85.85	1.27	0.91	0.53	-1013.00	1168.57
	Growth	0.32	4.71	0.06	0.07	0.96	-59.48	60.11
	Dividend yield	0.01	0.03	0.79	0.50	0.70	-0.34	0.37
1	(Constant)	-0.26	2.20		-0.12	0.92	-9.72	9.20
	Earning volatility	5.84	6.07	0.55	0.96	0.44	-20.29	31.97
	Size	0.00	0.00	-0.27	-0.48	0.68	0.00	0.00
2	(Constant)	-2.52	3.69		-0.68	0.62	-49.47	44.42
	Earning volatility	2.78	7.67	0.26	0.36	0.78	-94.64	100.19
	Size	0.00	0.00	-0.24	-0.39	0.76	0.00	0.00

	Payout ratio	5.33	6.58	0.58	0.81	0.57	-78.23	88.89
1	(Constant)	-2.70	2.77		-0.98	0.43	-14.62	9.22
	leverage	40.27	33.08	0.66	1.22	0.35	-102.07	182.62
	growth	-1.15	2.91	-0.21	-0.40	0.73	-13.66	11.36
2	(Constant)	-8.58	1.92		-4.48	0.14	-32.93	15.77
	leverage	-0.03	16.59	0.00	0.00	1.00	-210.84	210.79
	growth	5.48	2.12	1.02	2.59	0.23	-21.44	32.39
	payout ratio	13.62	3.74	1.48	3.65	0.17	-33.84	61.08

The values in the above table show that dividend yield is not contributing a significant change in outcome variable. This can be interpreted with the value of t which is ( $t=-.14$ ). Also the p values of model 1 and model 2 are insignificant which is also explaining that the addition of third predictor i.e. Dividend yield is not significantly contributing in predicting the outcome i.e. price volatility. The values of standardized  $\beta$  of dividend yield shows that increase in one standard deviation ( $SD = 42.67$ ) increases the outcome variable by (.19x.75=.14) standard deviations. The values in the above table show that payout ratio is contributing significant change in outcome variable. This can be interpreted with the value of t which is ( $t=-.81$ ). The p values of model 1 and model 2 are insignificant which is explaining that the addition of third predictor i.e. payout ratio is not significantly contributing in predicting the outcome i.e. price volatility. The values of standardized  $\beta$  of payout ratio shows that increase in one standard deviation ( $SD = .08$ ) increases the outcome variable by (.58x.75=.44) standard deviations. The confidence intervals in the above tables showed that none of the results can be generalized to the population as values of lower and upper bound is significantly different from each other.

## VI. CONCLUSION

The present study is conducted to investigate the affect of corporate dividend policy on stock price volatility. A sample of 11 firms from KSE is inspected for the period of five years from 2001-2014. The experiential estimation is based upon a regression analysis between the dividend policy and stock price volatility along with controlled variables of size, leverage, growth and earning. The results of present study consider the previous studies of Allen and Rakhim (1996); Nishat and Irfan (2006); Asghar et al, (2011) and Nazir et al (2010) and figured dependency of price volatility on various other variables is site specific but additionally depends on the actual structure of current market. The stable along with efficient markets are easy to predict but the actual markets, where high discuss price fluctuations exists then it can be difficult to layout a model which could forecast the price ranges and returns in the more accurate method. In present study results showed that dividend yield, earning volatility, leverage, payout ratio, size and growth in asset have no relationship with price volatility because the data taken was very small as compared to previous studies, i.e. Nazir et al. (2010); Nishat and Irfan (2006) . Moreover some data was also missing and it was not present in KSE and specific company's site which may also affect results. Time constraint is also one of the limitations of this study. This work can further be extended

by analyzing the large firms, with large sample size and by including diverse aspects or dimensions.

## REFERENCES

- [1] Adjasi, C. K. D. (2009), Macroeconomic uncertainty and conditional stock-price volatility in frontier African markets: Evidence from Ghana. *The Journal of Risk Finance*, 10(4), 333-349.
- [2] Ahmad, W., & Ullah, S. (2011). Predictability power of firm's performance measures to stock returns: A comparative study of emerging economy and developed economies stock market behavior. Karlstad Business School, Master's thesis of business administration.
- [3] Akbar, M., & Baig, H. H. (2010). Reaction of stock prices to dividend announcements and market efficiency in Pakistan. *The Lahore Journal of Economics* 15(1), 103-125.
- [4] Akdeniz, L., Salih, A., & Ok, S. (2007). Are stock prices too volatile to be justified by the dividend discount model? *Physica A*, 376 433-444. doi:10.1016/j.physa.2006.10.097.
- [5] Allen, D. E., & Rachim, V. S. (1996)" Dividend policy and stock price volatility: Australian evidence." *Applied Financial Economics*, 6, 175-188.
- [6] Amidu, M., & Abor, J. (2007). Determinants of dividend payout ratios in Ghana. *Journal of Risk Finance*. 7(2), 136-145.
- [7] Asghar, M., Shah, S., Z. A., Hamid, K., & Suleman, M. T. (2011). Impact of dividend policy on stock price risk: Empirical evidence from equity market of Pakistan. *Far East Journal of Psychology and Business*, 4(1), 45-52.
- [8] Asamoah, G. N., (2010). Impact of dividend announcement on share price behavior on Ghana. *Journal Of Business And Economic Research*, 8(4), 47-58.
- [9] Bhattacharya, S. (1979), Imperfect information, dividend policy, and 'the bird-in-hand' fallacy. *Bell Journal of Economics*, 10 (1), 259-270.
- [10] Fama, E. F., & French, K. R. (1992). The cross-section of expected stock returns. *The Journal of Finance*, XLVII (2) 427-465.
- [11] Hussainey, K., Mgbame, C. O., & Mgbame, A. M. C. (2011). Dividend policy and share price volatility: UK evidence. *The Journal of Risk Finance*, 12(1), 57-68.
- [12] Khan, N. U., Burton, B. M., Power, D. M. (2010). Managerial views about dividend policy in Pakistan. *Managerial Finance*, Vol. 37(10), 953 – 970. DOI 10.1108/03074351111161600.
- [13] Modigliani, M. H., & Miller, F. (1961). Dividend policy, growth, and the valuation of shares. *The Journal of Business*, 34(4), 411-433.
- [14] Mollah, S. (2011). Do emerging market firms follow different dividend policies? Empirical investigation on the pre- and post-reform dividend policy and behavior of Dhaka Stock Exchange listed firms. *Studies in Economics and Finance*, 28(2), 118-135.
- [15] Nazir, M. S., Nawaz, M. M., Anwar, W., Ahmed, F. (2010). Determinants of stock price volatility in Karachi stock exchange: The mediating role of corporate dividend policy. *International Research Journal of Finance and Economics*, 55, 1450-2887.
- [16] Nishat, M., Irfan, C., M. (2006). Dividend policy and stock price volatility in Pakistan. (M Phil Thesis submitted to Higher education commission). University of Karachi. Karachi, Pakistan

- [17] Rashid, A., & Rahman, A. (2008). Dividend policy and stock price volatility: Evidence from Bangladesh. *Journal of Applied Business and Economics*, 8 (4), 71-80.
- [18] Renneboog, L. (2007). Control structures and payout policy. *Managerial Finance*, 33(1), 43-64.
- [19] Robinson, J. (2006). Dividend Policy Among Publicly Listed Firms in Barbados. *Journal of Eastern Caribbean Studies*, 31(1), 1-36. Retrieved from EBSCOhost.
- [20] Stacescu, B., (2004). Dividend policy in Switzerland. PhD student, Swiss Banking Institute and NCCR Finrisk Plattenstrasse 14, 8032 Zurich.
- [21] Twaijry, A. A. A. (2007). Dividend policy and payout ratio: Evidence from the Kuala Lumpur stock exchange. *The Journal of Risk Finance*, 8 (4), 349-363.

#### AUTHORS

**First Author** – Muhammad Abrar-ul-haq, P.hD Scholar, School of Economics, Finance and Banking, Universiti Utara Malaysia  
Email:abrarchudhary@hotmail.com

**Second Author** – Kashif Akram, P.hD Scholar, School of Business and Management, Universiti Utara Malaysia,  
Email:kashif.akram@iub.edu.com

**Third Author** – Muhammad Imdad Ullah, P.hD Scholar, School of Business and Management, Universiti Utara Malaysia,  
Email:imdadbzu@gmail.com

# Micro-level Determinants of Rural Poverty in Pakistan

Muhammad Abrar ul haq\*, Kashif Ayub\*\*, Muhammad Imdad Ullah\*\*\*

\* Ph.D scholar, School of economics, finance and banking, University Utara Malaysia

\*\* Visiting lecturer, Department of management Sciences, The Islamia University of Bahawalpur

\*\*\* P.hD Scholar, School of Business and Management, Universiti Utara Malaysia

**Abstract-** The current study identifies the factors affecting rural household poverty by using first hand data, which was collected through rural household survey of southern Punjab. A Logit model used to check the relationship among dependent and independent variables. Dependency ratio, higher fe-male labor force, person per room, lowering household size, higher education, higher household participation rate Gender of household head, fe-male to male ratio and access to basic utilities provided by the government can be alleviate poverty in studied area. Poverty will be more alleviate in rural areas of Pakistan, if government improve basic infrastructure and empowerment of rural peoples and market access facilities.

**Index Terms-** Empowerment, Market access, Poverty alleviation, Southern Punjab

**Jell Classification:** D14, E24, I21, O12

## I. INTRODUCTION

Form last several decades lots of developing countries of the world have to pay more attention to poverty alleviation. Lots of research work has been done on issuing of poverty mitigation and its long-run economic & social impact. In the view of fact the poverty alleviation is still major agenda of all economies. In 2000 The World Bank has published three international reports and in 2000/2001 The World Bank issues a report which mainly focused the issue of poverty. This practices has started sciences 1980 and in 1990 on the same subject. In fact, poverty in rural areas is more prominent with multidimensional aspects. In 2003 the international labor organization published a report in his 91<sup>st</sup> session about issue of poverty and ILO also focused on poverty issue.

Now we narrow down the issue of poverty in Pakistan after briefly discussing the importance of issue of poverty. There is an adequate proof that poverty increased in 1960's, decrease quickly in the 1970s and 1980s again come back in 1990s. In 2000s again it is has start decreases [Government of Pakistan (2006), Arif et al. (2001), ali and tahir (1999), Amjad and kemal (1997)]. Furthermore, according to world bank (2000) is harder to understand the decreasing trend in poverty. Through demographic factors which affect employment level, remittances, workers, dependency ratio, labor force, assets ownership and access, real wage rates and employment. However the higher gigantic poverty exists in rural areas of Pakistan rather than urban areas.

In literature, whenever poverty alleviation is taken as a key problem of economy, efforts have been started to alleviate

poverty through improving many areas which affect the rural households economically and socially. Because poverty alleviation has one of primary objective of government policies and government made efforts to reduce household poverty from last few decades in Pakistan by increasing job facilities, improving health and education facilities, sustainable growth, improving infrastructural facilities and reduce financial crisis but slightest importance has been given at micro or district level poverty reduction. Now we discuss here some studies carried on poverty alleviation and about the factors affection household poverty.

Chaudhry et al. (2008) investigate the factors which affect urban poverty in Multan region by using Governance as a key factor. The current study pays more attention on governance at local level and calculates its impact on urban household poverty in Multan. In current study poverty and good governance measured by using first hand data which was collected through random household survey of 200 households. Bi-variate model was used for analyze the impact of governance on household poverty. Logit model was used for multivariate analysis in current study and the dependent variable was poor which assign dichotomous values. Governance is a key variable and its measure by set of proxy variables and other serving variables were female labor force, dependency ratio, education of household head, participation rate, assets, persons per room and informal sector workers. And result shows that there was negative relationship between good governance and urban household poverty.

Sabir et al, (2006) calculate the intensity and its depth of small formers poverty by using head count ratio and local poverty line (Rs.748). The current study also investigates the determinants of household poverty of small formers in region of central Punjab by using binary logistic model. Current study based on primary data which was collected through the random sampling of 300 households from three district of central Punjab. Current study conclude that household poverty of small former were affected by age of head of household, low price agriculture output, high price of agriculture inputs, larger household size, education of head of household, number of depended.

Chaudhry (2003) studied household poverty in district Bahawalpur by using micro determinants of household poverty. Logit regression models and income regression models were used to identifying the factors affecting the household poverty in region. The current study concluded that efficient economic infrastructure, higher agriculture production, improving educational and health services were consider the strategy actions to reduce household poverty in studied region.

Haq (2013) calculate the socio-economic empowerment of rural household by generating a composite index through Principle



component analysis. Thirty eight indicators are used for measuring socio-economic empowerment. Study also analyzes the severity of poverty in studied region and estimate the relationship among household poverty and socio-economic empowerment of households. The study concluded that the incidence of poverty is higher in rural area of Punjab.

Haq and khan (2013) investigate the factors affecting the participatory poverty of the rural household by using first hand data which was collected through household survey of Division Bahawalpur and concluded that education of head household, occupation of head, household size, social participation are the main factors which affect participatory poverty of the rural household. Later studies of Haq et al. (2015) also estimate the detements of rural household poverty in region Bahawalpur District by using the data of a village.

Khan et al. (2015) analyzed the factor of rural poverty by taken a special focus on socio-economic empowerment of rural households. They calculated socio-economic empowering by using principle component analysis and then check its impact on rural household poverty and study concluded the strong inverse relation among socio-economic empowerment and household poverty.

After analyzing the existing literature, now discuss the importance and subject of matters of current study. This study is focused rural area of Southern Punjab. However key objectives of current work are:1) To explore the important projects of the Government to removing household poverty and improving empowerment of rural household, 2) To calculate the current

rural poverty situation and its trend in studied region, 3) To identifying the factors which affect rural household poverty in region and in last recommend suitable policy implications for poverty alleviation in Pakistan and especially in Southern Punjab.

## II. DATA AND METHODOLOGY

Bahawalpur Division is administrative division of southern Punjab. The empirical estimation of current study based on 1<sup>st</sup> hand data which collected from rural areas of Bahawalpur. Due to difficulties of data collection in rural areas, the current study selected one village (19/F.W: Tehsil Hasilpur) consisting 110 household. A random sampling technique was used for data collection from the rural area of Bahawalpur by conducting a household survey.

In current study, the poverty line adopted from Planning Commission of Pakistan (2014) which is Rs. 1745.00 (2550 calories). Head count ratio method is used in current study for measuring incidence of rural poverty between households. Furthermore, a Logit model is used for empirical analysis among the factors which affect the rural household poverty in studied region. In current study explained variable have only two values (dummy variable), assigned vale 1 is household is poor and otherwise 0. The current study based on some important quantitative variables and as well some qualitative variables. Selected variables for econometric model are listed in Table 1.

**Table 1: List of Variables and its Coding**

Variables	Description of Variables
<b>Explained Variable</b>	
POVT	1 if household is poor, and 0 otherwise
<b>Explanatory variables</b>	
HMRT	1 if household produce for market and access to it, and 0 otherwise
PROM	Persons per room among the household
ASET	1 if household has physical assets, and 0 otherwise
LDHL	1, if household has landholding , and 0 otherwise
AGEH	Age of household head in years
PART	Participation rate
HHLT	1 if household head is literate, and 0 otherwise
GENDER	1 if household head is male, and 0 otherwise
FRTM	Female-male ratio (member)
EDUC	Education codes (education level of household)
DPNR	Dependence ratio
HISZ	Household size
SERO	1 if household head is services occupation, and 0 otherwise

On the basis of existing literature and theoretical frame work , dependency ratio (DPNR), Age head of household (AGEH), household size (HSIZ), female-male ratio (FRTM), and person per room have positive relationship among rural poverty alleviation and other independent variables has negative relationship with poverty alleviation.

### **Trend of rural poverty in southern Punjab:**

In rural areas of Pakistan, nearly 68 percent of population has living and poverty is higher in rural areas<sup>15</sup> of Pakistan rather

than urban areas. However, in southern Punjab rural household poverty is more complex and severs, it is nearly 40 percent in the region of division Bahawalpur, Multan, Dera Ghazi Khan.<sup>16</sup> Severity of poverty increases in 1990s and then later than stat declining. BRDP's report has been shows that poverty has declined by nearly 33 percent (within last nine years) in the studies region. 40 percent households are being poor according to

<sup>15</sup> 36 percent of the rural population is poor(FBS 2002)

<sup>16</sup> International fund for agricultural development (2001)

result of current study and that result is same as BRDP (2009). On the basis of current result it is concluded that poverty is reduced in current studied area of southern Punjab due to projects of BRDP and Government policies.

### III. RESULTS AND DISCUSSIONS

The empirical results of current study stated that in southern Punjab poverty is higher than rest of Punjab. Factors which affect rural household poverty are determined by using a Logit model in current study. The results of Logit regression are discussing in below table.

**Table 3: Logit Regression Analysis**

Explanatory Variables	Coefficients	Odds ratios
Constant	-8.43**	0.63
HMRT	-1.87*	0.74
PROM	1.31*	0.49
ASET	-0.45**	0.14
LDHL	-0.76*	0.67
AGEH	0.89*	2.45
PART	2.19*	0.41
HHLT	-0.46**	0.94
GENDER	-0.83**	3.46
FRTM	0.56**	0.35
EDUC	-0.49**	0.97
DPNR	0.92**	2.38
HISZ	0.12*	0.76
SERO	-0.61**	0.69

Number of observations = 110, Loglikelihood = -32.71  
DF = 13, P-Value = 0.000

**Notes:** \* 5 percent level of significant.  
\*\* 10 percent level of significant.

Education is a very important phase of heterogeneous of employment. High educational aptitude might be require a healthier position of service opportunities and mainly in rural contest a good awareness of the bursting potential of innovative agricultural techniques. Education enhances the understanding and visualization. Educated person have more aware about their duties and more aware about their legal and social rights. In this study, average education calculated by adding the points (0 if their household members have no education, 5 if the education is at secondary level, 10 if the education is at college or university level) divided by total number of households and results shows that the increase in average education reduce the chance poverty. Analogous relationship is observed for education of household head and poverty. Poverty reduces by increasing the education of household head.

Size of Household is considered as a key factor affecting poverty especially in remote areas of Punjab, due to higher joblessness ratio and higher reliance ratio in rural region. In rural areas, a large number of old age household member and children contribute a little in income of that household, so for that population is a big hurdle in way of poverty declining. In current studies dependent member considered below than the 14 year and above the 65 years and results reveals that there is a positive

relationship between household size and poverty. Probability of being poor increases as increases the household size and result is significant at 10 percent of level.

In Pakistan majority of families considered a lucky thing to birth of a male child rather than female child's birth. In rural areas of Pakistan it's considered that the male child to be help full member to their family because they augment families' income when mature up and there for its causes to reduce poverty of that household. In result of current study there is a positive association between female-male ratio and poverty. Poverty of being poor increased by increasing the ratio. And also observed the relationship female-male ratio of workers, study shows that female labor force has significant contribution in the area. Probability of being poor decreased by increases the ratio of female workers.

Current study has also found a significant and negative relationship between poverty alleviation and the number of livestock, assets, Gender of household head and services occupation of head of household. Probability of being poor reduced by increasing of each factor. Person per room and age of head of household are also the significant factors affecting poverty, and there is positive association between them. Probability of being poor increased by increasing them.

In current study market access is taken as a binary variable, which is significant at less than 5 percent. There is negative relationship between poverty and HMRT, chance of poverty decreases on that household how produce for the market rather than those who not have any access to market.

### IV. SUMMARY AND POLICY MEASURES

For poverty alleviation lots of methods have been adopted by government at all over in Pakistan from since its creation and some time may achieve good economic growth rate in different years. Poverty alleviation and high growth rate was resulted by the good efforts by the governments and international organizations. Evidences proved that the poverty alleviation at micro level was also on right track but it's more significant with the support with macroeconomic stability in Pakistan.

The empirical analysis proved that the problem of poverty is more severe in rural areas rather than urban areas of the country. The poverty level and its trend in rural areas of Punjab and NWFP are almost same. The result of current study shows that almost 40 percent household are poor and it's higher amongst other rural areas of province of Punjab.

Factors affecting household poverty in rural Punjab epically in studied area are also identified by using Logit model in current study. The key outcomes of current empirical analysis are summarized below.

- i. Age of head of household. Dependency ratio, size of household, persons per room, female to male ratio are highly allied with rural household poverty and has positive relationship between them and household poverty. Probability of being poor increases when that variables are increased.
- ii. Female labor participation, market access, education, overall participation rate, production for market, Gender of household head, assets and livestock has inverse

relationship with poverty. Probability of being poor reduce when value of these variables increases.

Because poverty alleviation has one of primary objective of government policies and government made efforts to reduce household poverty from last few decades in Pakistan. Government introduces poverty alleviation policies in 2001 in reply of increasing trend of poverty in 1990s and in the result of these policies the trend of household poverty start falling at all over Pakistan. Now it's more care full need to re address this problem in the age of globalizing world by focusing on new upcoming strategies. This may be the problem of physical economic infrastructure, microfinance, marketing and functioning of the market at both macro and micro level.

On the basis of current study's result it's recommended that government of Pakistan and also international institution must pay extraordinary focus to market access, improve governance and other socioeconomics variables, basic infrastructure which causes to remove rural household poverty in Pakistan. International institution also focuses to conduct surveys independently by hiring the local staff and local researcher to calculate the projects development and progress.

#### REFERENCES

- [1] Asian Development Bank (2002). Country Strategy Progress. 2002-2006, Manila: ADB
- [2] Ali, S. S, and Sayyid T. (1999) 'Dynamics of Growth, Poverty and Inequality in Pakistan', The Pakistan Development Review 38 (4): 337-858
- [3] Amjad, R. and Kemal, A. R. (1997). 'Macroeconomic Policies and Their Impact on Poverty Alleviation in Pakistan', The Pakistan Development Review 36 (1): 39-68.
- [4] Arif, G. M, Hina Nazli and Rashida Haq (2000). 'Rural Non- Agricultural Employment and Poverty in Pakistan', The Pakistan Development Review 39 (4): 1089-1110.
- [5] Arif, G. M. (2006) Targeting Efficiency of Poverty Reduction Programs in Pakistan, Pakistan Resident Mission Working Paper No. 4, May. Islamabad: Asian Development Bank.
- [6] Azid, T., Aslam, M. and Chaudary, M.O.(2001). 'Poverty, Female Labor Force Participation, and Cottage Industry: A Case Study of Cloth Embroidery in Rural Multan', The Pakistan Development Review 40 (4): 1105-1118.
- [7] Bahawalpur Rural Development Project (2000). Baseline Study, Bahawalpur Rural Development Project, Planning and Development Department, Government of Punjab, Bahawalpur: BRDP.
- [8] Bahawalpur Rural Development Project (2006). BRDP Phase II, Evaluation Report. Bahawalpur: BRDP.
- [9] Chaudhry, Imran S. (2003). 'An Empirical Analysis of the Determinants of Rural Poverty in Pakistan: A Case Study of Bahawalpur District with Special Reference to Cholistan', Unpublished Ph.D. Thesis, The Islamia University of Bahawalpur: Pakistan.
- [10] Chaudhry, Imran S., Malik, S. and Ashraf, M. (2005). 'Poverty in Cholistan: Profile and Correlates', Paper Presented at 21st Annual General Meeting and Conference, Pakistan Society of Development Economists: Islamabad, 19th -21st December.
- [11] Chaudhry, Imran S., Malik, S. and Imran, Asma (2006). 'Urban Poverty and Governance: The Case of Multan City', The Pakistan Development Review 45 (4): 819-830.
- [12] Federal Bureau of Statistics (2002). Poverty in the 1990s' PIHS, Government of Pakistan: Islamabad
- [13] Federal Bureau of Statistics (2014). "Poverty profile in Pakistan" using data PIHS (2010-11), Government of Pakistan: Islamabad
- [14] Government of Pakistan (2001). Interim Poverty Reduction Strategy (I-PRSP), Ministry of Finance and Poverty Reduction Cell, Planning Commission: Islamabad.
- [15] Government of Pakistan, (2005-2006). Pakistan Economic Survey, Federal Bureau of Statistics: Islamabad
- [16] Haq M.A and Khan, R. E. A (2013) of Participatory Poverty in Pakistan: A Case Study of Rural areas of Division Bahawalpur" in 5th South Asian International Conference Dec 2-4, 2013
- [17] Haq, M. A., Nawaz, M.A., Mehtab, N., and Cheema, A. K. H. (2012) "Determinants of Wage Growth: An Empirical Analysis of Bahawalpur" Business and Economic Research, Vol. 2, No. 1
- [18] Haq, M. A., Razani, M. J. and Ayub, K (2015) "Poverty in Pakistan: Evidence from Project Area of Asian Development Bank in Southern Punjab", Journal of poverty, Investment and Development, Vol 8, Issue 2.
- [19] International Fund for Agricultural Development (2001). Rural Poverty Report-2001: The Challenge of Ending Rural Poverty. Oxford: Oxford University Press.
- [20] International Labor Organization (2003). working out of poverty. Report of the Director-general in international Labor conference. Geneva: ILO.
- [21] Jafri, S. M. Younas (1999). 'Assessing Poverty in Pakistan' in a Profile of Poverty in Pakistan, Mahbub-ul-Haq Center for Human Development: Islamabad.
- [22] Kemal, A. R. (1995). 'Poverty Alleviation in Pakistan: An Evaluation of Public Strategies and Policies Adopted for Poverty Alleviation', Organized by Institute of Policy Studies: Islamabad.
- [23] Khan, R. E. A., Rehman, H. and Haq, M. A. (2015) "Determinants of Rural Household Poverty: The Role of Household Socioeconomic Empowerment", *American-Eurasian J. Agric. & Environ. Sci., Vol. 15, Issue 1, pp. 93-98*
- [24] Khan, T., Methab, N. and Haq, M. A. (2012) "Gender Disparity in Economic Returns to Higher Education: Evidence from Private Formal Sector of Bahawalpur (Pakistan)" Interdisciplinary Review of Economics and Management, Vol. 2, No.
- [25] Malik S. (1996). 'Determinants of Rural poverty in Pakistan: A Micro Study,' The Pakistan Development Review 35 (2): 171-187.
- [26] Malik S. J. (2005). Agricultural Growth and Poverty: A Review of the Evidence, ADB Pakistan Resident Mission working Paper No.2, Islamabad: Asian Development Bank.
- [27] Malik, S. (1992). A Study of Rural Poverty in Pakistan with Special Reference to Agricultural Price Policy, Unpublished PhD Thesis, University of Sussex: U.K.
- [28] Malik, S. Sharif, Imran and Jamal Z. (2000). 'Rural Poverty Alleviation Pakistan: Land Redistribution as a Direct Policy Measure,' Journal of Rural Development 33(1): 69-77.
- [29] Rowntree, B.S. (1901). Poverty: A Study of Town Life, Macmillan.
- [30] Siddiqui, Rehena (2001). Gender Dimensions of Poverty in Pakistan, paper presented at the 'Asia and Pacific Forum on Poverty: Reforming Policies and Institutions for Poverty Reduction' Asian Development Bank: Manila.
- [31] World Bank (2000). Poverty in Pakistan: Issues, Priorities and Policy Options: a Concept Note, Paper Presented at a Seminar. Islamabad: World Bank.

#### AUTHORS

**First Author** – Muhammad Abrar ul haq, Ph.D scholar, School of economics, finance and banking, University Utara Malaysia, E-mail: abrarchudhary@hotmail.com  
**Second Author** – Kashif Ayub, Visiting lecturer, Department of management Sciences, The Islamia University of Bahawalpur, Email:kashi.gondal@yahoo.com  
**Third Author** – Muhammad Imdad Ullah, P.hD Scholar, School of Business and Management, Universiti Utara Malaysia, Email:imdadbzu@gmail.com

# The Influence of Individual Characteristics on Organization Performance and Job Satisfaction

Asad-ur-Rehman\*, Muhammad Imdad Ullah\*\*, Muhammad Abrar-ul-haq\*\*

\* P.hD Scholar, School of Business and Management, Universiti Utara Malaysia

\*\* P.hD Scholar, School of Business and Management, Universiti Utara Malaysia

\*\*\* P.hD Scholar, School of Economics, Finance and Banking, Universiti Utara Malaysia

**Abstract-** Current study intended to describe the understanding of the contact among organization performance and dimension of individual characteristics (i.e. gender, education and age) and acquitting information of job satisfaction from middle and upper management of NBP, ABL and MCB especially from area Rawalpindi and Islamabad. The aim of current study was to analyze the impact of individual characteristics on job satisfaction and organizational performance. Correlation and regression are used to analyze the moderating role of relationship quality in influencing the relationship. The out comes to current study diagnose the direct relationship among job satisfaction and individual characteristics. Furthermore, relationship is directly and significantly affected by relationship quality. Current study will also be helpful to improve job satisfaction and performance of organization.

**Index Terms-** Job satisfaction, Individual characteristics, Organization Performance, Regression Analysis.

## I. INTRODUCTION

Reputation of the firms and its delivery services has been directly affected by the employees because the organizations are more concerned now a day about to hire their employees. The main industry which depends on the services of its employees is the banking industry of any country. Today's world considered labor as a human capital which directly affected by the performance and efforts of labor. So for that the performance, partnership quality and value of the firms are directly affected by individual characteristics. More competition is just resulted due to globalization changes in banking sector, and human resources of the firms determine the success of firms due to increase competitions. McMahan and Wright (1992) defined "Strategic human resource management (HRM) being the major discipline as the model of designed human resource deployments and actions proposed to permit the firm to attain its goals. They highlighted that the area of strategic HRM is concerned to the decisions of HR practices, human capital resource composition, behaviors and the success of these decisions with in the competition and different business strategies (p. 298)".

Banking sector's growth now a days is very high as weigh against before but some projects has fall to gain high output just due to its relationship quality, and the major factor is like people's education, for example mobile banking services has been launched by Telenor by using tamer bank with label of Easy

paisa, and that did not get good feed back because people have not good confidence and not feel reliable trend to send their cash through that services.

Strong relationships are made by the factor of education, for example now most of companies used mobile banking service to send quick information to their customers when transaction is made, its depend on its services how much information they send to their customer more quickly. In current scenario it's expected that application developer will added alerts, default transactions, standard beneficiary, amount format, time & date format, and also added language which is generally used by community.

## Problem statement:

After the globalization and agreement of privatization the banking sector grow fastly in pakistan but the current growth of Pakistan's banking sector is still low than foreign banks' growth. The foreign bank's growth directly depends on the quality of relationship which improved through HR of that organization. According to Gellert & Schalk (2012) "direct relationship between individual characteristics and relationship quality and firm performance as evident from the literature shows the concern towards this area particularly in the banking sector due to the initiation of Islamic banking in 21st century". However the current study used aspects of personality which leads to individual characteristics and leader member exchange and as well as other aspects of individual characteristics like pay and experience etc are surrounded.

## Purpose of the Study:

Gellert and Schalk (2012) done research on performance and the age on the perceptions of relationship quality, but his work ignore the other factor which affects individual characteristics like as experience, age and education. And the other thing is, that work has done in context of European surroundings, so for the implementation in the context of Pakistan environment which arise a need for this current study to be filled that gap. Current study analyzes the impact of individual characteristics of gender, age, education on the performance custody the role of perceptions of relationship quality as a moderating variable.

## II. LITERATURE REVIEW

It's essential to know the impact in different ways by young employees rather than those of older employees, it's also essential to know, how quality improved by perceive and set



standards from young employees and what are the benchmarks for older employees regarding eminence of association. Franz and Rene (2012) said “Cooperation between members will also be dependent on age factor if age difference is low then range of cooperation will be large because some time cooperation requires informal mode between members so that if age difference is high then using of informal means will be less that will leads to low quality of relationship”.

Magoshi & Chang (2009) and Sakuda (2011) “argued about age diversity and its effects on the quality of relationship some of the arguments said that diversity creates positive effect on the quality of the relationship and some of those say that diversity of gender has negative effects on the quality of the relationship. All over the world people have great interest on the research of diversity related issues but the fact is that most of the researches have been conducted on western societies and due to cross cultural issues it is recommended that research which is conducted on western society may be having some problems in implementing those on nonwestern society”.

Khoreva (2011) said “if the gender pay gap result of discernible differences between individuals for instance differences in education, skills, length of work experience, it is not surprising that individuals do not perceive it. On other hand , if the gender pay gap is due to unexplained variables such as inequality and various types of discrimination, individuals might perceive it and struggle against it”.

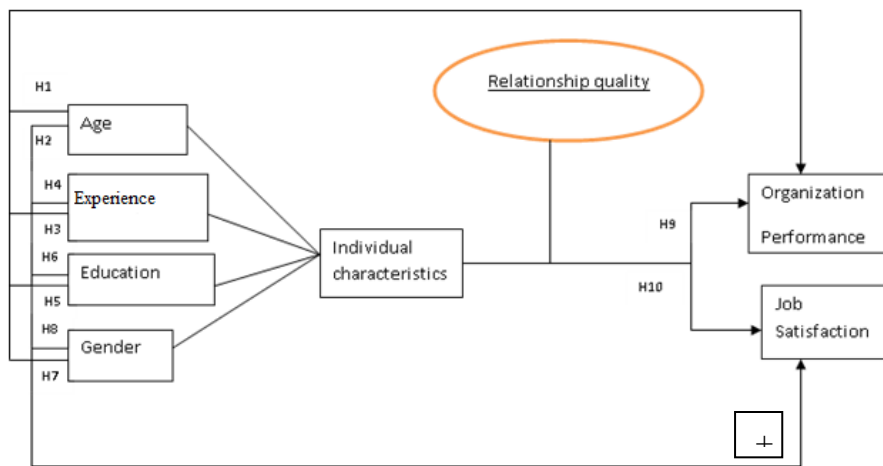
“Individuals who are more educated are compensated more without gender differences. Men are paid in case of labor work because it is perceived that man work more hard as compared to

women. The individuals who are more educated as judge against to who are less educated make out more gender difference” said by Judge & Livingston (2008) and Khoreva (2011).

According to Vicente (2011) “human capital is the most important factor which brings change in employee productivity and increase firm performance the investments on human capital leads towards high performers and excellent results organization financial results. Eventuality studies using organizational characteristics as moderators are needed to gain further insights into human capital-performance relationships. Human resource practices are more effective in complex or large organizations as compared to small organizations. There should be more focus on organizational size while using Hr practices .Unfortunately, studies that have analyzed the impact of human capital on firm performance only considered organizational size as a control variable or took samples of either large or small firms. Therefore ignoring the potential influence of organizational size on the relationship between human capital and firm performance and preventing comparative studies between large and small 5/firms”.

Malik et al. (2011) analyze “employee Performance basically depend on many factors like performance appraisals, employee motivation, employee satisfaction, compensation, training and development, job security, organizational structure and other, but our area of study is focused only on two basic factors: Employee motivation and organizational Structure, these two factors highly influence the performance of employees”.

### III. THEORETICAL FRAMEWORK



#### Hypotheses:

- H<sub>1</sub>:** Organization performance has direct relation with Age of the employee.
- H<sub>2</sub>:** Job satisfaction has a positively affected by Age of the employee.
- H<sub>3</sub>:** Organization performance has positively affected by Experience of the employee.
- H<sub>4</sub>:** Job satisfaction has positively affected by Experience of the employee.

- H<sub>5</sub>:** Organization performance has positively affected by Education of the employee.
- H<sub>6</sub>:** Job satisfaction has positively affected by Education of the employee.
- H<sub>7</sub>:** Organization performance has positively affected by gender.
- H<sub>8</sub>:** Job satisfaction has positively affected by gender.
- H<sub>9</sub>:** organization performance and individual characteristics has effected by relationship quality.
- H<sub>10</sub>:** Job satisfaction has affected by relationship quality.



**Research Methodology:**

For current study the researcher adopts quantitative approach, as statistical tools were used for hypothesis testing and for ultimate outcomes. Effects of individual characteristics are measuring causally on job satisfaction and organizational performance and relationship quality was taken as moderating variable for organizational performance.

**Instrument Development:**

The instrument used for the data collection was a survey questionnaire containing structured close ended questions. Ordinal data was analyzed on the 5-point likert-scale. The questionnaire had two sections with section A as the demographic profile and section B contained the responses on a 5-point likert-scale. Section A catered information on the name of the individual along with gender, age, experience and education; with age being divided into groups of 20-30, 30-40, 40-50, 50 and above, experience options included no experience, less than 1 year, 5-10 years and more than 10 years and education included the options of no formal education, intermediate or below, bachelors, masters, Ms/M-Phil and PhD. The second part contained the questions on a 5-point scale measuring the responses on the variables. This part contained different items to measure responses on the variables with questions being adapted from various research papers; 10 items on individual characteristics (containing 3 items on age,3 on gender,2 on experience and 2 on education) were adapted from the research paper of Adit et al (2005),6 items on relationship quality(containing 3 items on autonomy and 3 on cooperation)were adapted from the paper of Gellert and Schalk (2012),6 items of job satisfaction adapted from WELCO (2011) and 6 items of organization performance adapted from Fox (2005). All items were measured using 5-point likert-scales (1-strongly agree and 5- strongly disagree)

**Population and Sample:**

Top and middle level employees of Pakistan’s banking industry are taken as a population of current study. ABL, NBP and MCB’s top and middle level employees from Islamabad and Rawalpindi region were considered as sample for current study. Due to time limitations convenience sampling technique was use for data collection and collect data from 396 individuals.

**Data collection Procedure:**

Collect data through self administrated structured questionnaire. Through personal distributions and through emails 450 questionnaires were distributed and 396 individuals responded. Among these only 300 questionnaires were properly filled and that were used for further analysis of current study.

**Data analysis technique:**

Descriptive analyses were use for taken averages and percentages of variables and correlation and regression analysis were used to check the relationship between independents and dependent variables.

IV. RESULTS & DISCUSSION

**Demographic Analysis:**

From 300 respondent 119 are male and 2 female in the 30-40 year age group, who have masters degree and among them only 29 percent have 5-10 year job experience. Furthermore, 50 year or above old male employees are only 40 out of 300, and only 12 percent have master degree holder and only 4 percent have 10 year job experience. Total male employees were 264 out of 300 and 233 have master degree holder out of total.

**Table 1: Individual characteristics of the sample**

		Gender		Education				Experience			Total
		Male	Female	P.hD	MS/ M.Phil	Master	Bachelor	less than 1 year	5-10 years	Above 10 years	
Age	20-30	34	34	4	11	50	3	16	52	0	68
	30-40	119	2	3	23	88	7	30	86	5	121
	40-50	71	0	0	8	63	0	8	42	21	71
	50 Above	40	0	0	6	32	2	4	24	12	40
Total		264	36	7	48	233	12	58	204	38	300

**Descriptive Analysis:**

Table 2 shows descriptive analysis. Which shows that total sample size was 300 for which test was conducted. Furthermore, it also explains standard deviation, mean, kurtosis and skewness

of the sample data. The mean is “showing the arithmetic average of the scores obtained from respondents with standard deviation showing square root of variance from the mean. Skewness shows the degree of steepness whereas; kurtosis shows the degree of peekness of the shape of distribution”.

**Table 2: Descriptive statistics**

	<u>Mean</u>	<u>Std. Deviation</u>	<u>Skewness</u>		<u>Kurtosis</u>	
	Statistic	Statistic	Statistic	Std. Error	Statistic	Std. Error
AGE	6.8267	2.18954	.473	.141	-.696	.281
Gender	7.9511	1.58420	.183	.141	-.513	.281
Experience	4.7383	.72396	-.925	.141	.435	.281
Education	3.9700	1.34914	.462	.141	.182	.281
Cooperation	6.6789	2.20086	.023	.141	-.389	.281
Autonomy	6.4967	2.21888	.677	.141	-.533	.281
J.Satisfaction	16.4700	1.79847	.399	.141	-.380	.281
Org.Perf	11.9989	2.86702	.265	.141	-.793	.281

**Correlation Matrix:**

All individual characteristics have significant relationship with organization performance at 1% level of significance. Another explained variable “Job satisfaction” has also significant

association with all individual characteristics at 5% and 1% significance level excluding experience and age and detail shown in table 3.

**Table 3: Correlation Matrix**

	AGE	Gender	Experience	Education	Cooperation	Autonomy	J.Satisfaction	Org.Perf
AGE	1							
Gender	.127*	1						
Experience	.367**	.249**	1					
Education	.619**	-.149**	.471**	1				
Cooperation	.408**	.378**	.574**	.608**	1			
Autonomy	.584**	.515**	.373**	.422**	.678**	1		
J.Satisfaction	.080	.421**	.091	.135*	.537**	.297**	1	
Org.Perf	.442**	.278**	.503**	.363**	.678**	.467**	.193**	1

\*.Correlation is significant at the 0.05 level (2-tailed).

\*\*. Correlation is significant at the 0.01 level (2-tailed).

**Regression Analysis for Hypothesis Testing:**

**Table 4: Regression Analysis**

Hypothesis	Description	β	t-value	p-value
H1	Age → Organizational performance	.442	8.502	.000
H2	Age → Job satisfaction	.080	1.390	.166
H3	Experience → Organizational performance	.503	10.050	.000
H4	Experience → Job satisfaction	.091	1.584	.114
H5	Education → Organizational performance	.363	6.730	.000
H6	Education → Job satisfaction	.135	2.353	.019
H7	Gender → Organizational performance	.278	5.002	.000
H8	Gender → Job satisfaction	.421	8.008	.000
H9	Indiv.Char → RQ → Org.Perf	.507	4.945	.000
H10	Indiv.Char → RQ → Job.Satis	.671	5.730	.000

Notes: n = 300, Arrow indicates the direction of impact

## V. DISCUSSION

Current study analyzes the impact of individual characteristics on job satisfaction and organization performance and also analyzes the individual characteristics on job performance and organization performance by influence of individual characteristics. Results of current study shows that individual characteristics have considerable relationship with job satisfaction and organization performance but few independent variable has showed insignificant relationship (i.e. experience and age) on job satisfaction. 8 hypotheses were accepted out of 10 hypotheses and remaining two hypotheses are rejected. Discuss below in detail.

- The coefficient value of age is 0.195, which shows one year more age increase the 19.5 percent chance to increase organization performance. That's why H<sub>1</sub> is accepted.
- The coefficient value of age is 0.08, which shows one year more age increase the 8 percent chance to increase job satisfaction.
- The coefficient value of experience is 0.503, which shows one year more experience increase the 50.3 percent chance to increase organization performance. So for that hypothesis H<sub>3</sub> is accepted.
- The coefficient value of experience is 0.091, which shows one year more experience increase the 9.1 percent chance to increase job satisfaction. The result is insignificant statistically.
- The coefficient value of education is 0.363, which shows one year more education increase the 36.3 percent chances to increase organization performance. So for that hypothesis H<sub>3</sub> is accepted and result is significant at 5 percent level of significance.
- The coefficient value of education is 0.135, which shows one year more education increase the 13.5 percent chance to increase job satisfaction.
- The coefficient value of gender is 0.287, which shows that the male employee increases 28.7 percent chances to increase organization performance and result is significant at 5 percent level of significance.
- The coefficient value of gender is 0.421, which shows that the male employee increases 42.1 percent chances to increase job satisfaction and result is significant at 5 %.
- The coefficient value of individual characteristic is 0.507, which shows that the one percent increases in individual characteristic increases 50.7 percent chances to increase organization performance and result is significant at 5 %.
- The coefficient value of individual characteristic is 0.621, which shows that the one percent increases in individual characteristic increases 62.1 percent chances to increase job satisfaction and result is significant at 5 %.

## VI. RECOMMENDATIONS

According to the results of this study, it's suggested that the performance of any organization has been improve by improving

its relationship quality, for example the organization improve its cooperation and justice with employees. Furthermore, job satisfaction is also improved by improving relationship quality. According to the results of current study, experience and age have a positive relationship with job satisfaction but statistically insignificant, so, organizations should focus to hire aged and experienced personnel which may enhance the performance of organization.

## REFERENCES

- [1] Ahmad, A., Kashif-ur-Rehman, & Saif, M. I. (2010). Islamic Banking Experience of Pakistan: Comparison between Islamic and Conventional Banks. *International journal of business and management*, 137-143.
- [2] Gellert, F. J., & Schalk, R. (2012). The influence of age on perceptions of relationship quality and performance in care service work teams. *Employee Relations*, 44-60.
- [3] Goris, J. R. (2007). Effects of satisfaction with communication on the relationship between individual-job congruence and job performance/satisfaction. *Journal of Management Development*.
- [4] Gunnigle, P., Turner, T., & Morley, M. (1998). Strategic integration and employee relations: the impact of managerial styles. *Employee Relations*, 115-131.
- [5] Khan, M. A., Kashif-Ur-Rehman, Ijaz-Ur-Rehman, Safwan, N., & Ashfaq, A. (2011). Modeling link between internal service quality in human resources management and employees retention: A case of Pakistani privatized and public sector banks. *African Journal of Business Management*, 949-959.
- [6] Khoreva, V. (2011). Gender pay gap and its perceptions. *An International Journal*, 30(3), 233 - 248.
- [7] Scott, W. (1986). Gender: A Useful Category of Historical Analysis. *The American Historical Review*, 1053-1075.
- [8] Steven Pool, B. P. (2007). A management development. *Journal of Management Development*, 353-369.
- [9] Tung, A., Baird, K., & Schoch, H. P. (2011). Factors influencing the effectiveness of performance measurement systems. *International Journal of Operations*, 1287-1310.
- [10] Vicente Roca-Puig, I. B.-M. (2011). Combined effect of human capital, temporary employment and organizational size on firm performance. *Personnel Review*, 41, 4 - 22.
- [11] Wright, P. M., & McMahan, G. C. (2011). Exploring human capital: putting human back into strategic human resource management. *Human Resource Management Journal*, 93-104.
- [12] Yang, F. (2011). Work, motivation and personal characteristics: an in-depth study of six organizations in Ningbo. *Chinese Management Studies*, 272-297.

## AUTHORS

**First Author** – Asad-ur-Rehman, P.hD Scholar, School of Business and Management, Universiti Utara Malaysia  
Email:asadrehmaan@hotmail.com

**Second Author** – Muhammad Imdad Ullah, P.hD Scholar, School of Business and Management, Universiti Utara Malaysia  
Email:imdadbu@gmail.com

**Third Author** – Muhammad Abrar-ul-haq, P.hD Scholar, School of Economics, Finance and Banking, Universiti Utara Malaysia  
Email:abrarchudhary@hotmail.com

# “The Mayor of Casterbridge”: Attitude toward Changes and Challenges of Social Conventions.

Tazir Hussain

Badarpur, Assam, India

**Abstract-** The position of women in the 19th century was a critical one. The society was governed in the patriarchal mode. The public sphere was not accessible to women as it was to men. Various kinds of limitations were imposed on women's conducts especially in the fields of law, education and even on lifestyle. Again, side by side, there were various positive changes taking place around that time. For example, the Married Women's Property Act was passed in 1870 which protected the legal position of women within the family. The 19<sup>th</sup> century was also important as a time when feminist campaigns to improve the legal status of women were undertaken in areas such as vote, the family and reproduction. The family was traditionally viewed as a private zone that was largely beyond the reach of the concerns of law. The feminist campaigns, to secure equality within the family, was therefore, viewed as threat to the stability of family life. The grounds have been prepared by such writers as Mary Wollstonecraft, who argued about the position of women in her book *A Vindication of the Rights of Woman* as early as in 1792. All these brought a new perspective in the Victorian society. In terms of all these changes, it is really interesting to see how Hardy represents the position of women through the major women characters in his novel “The Mayor of Casterbridge”.

**Index Terms-** Character, Women, Society, Freedom

## I. INTRODUCTION

Much have been said and written about the representation of women characters in Hardy's novel. The scope of this subject is broad.

“Character is Fate” (Hardy 112), but Henchard's character demands an understanding of the other characters in relation to him, because it's not Henchard's character alone that brings in his tragic end. It's the character of the people as a whole that surround him and their responses to his life and death that probably goes up to make his fate.

In this paper, my attempt is to discuss three major women characters--- Susan, Elizabeth Jane and Lucetta Templeman. I would like to show how in these three women characters Hardy registers the trends between Victorian and modern sensibilities.

The initial impression of the opening chapter brings out Henchard's ‘bitterest temper’ (p19). He sells his wife to the sailor, Newson, in a mood of drunken frustration. The act of selling is a preparation that both Henchard and Susan has been confronting verbally long before they arrived at the Fair of Weydon-Priors. Michael has repeated this act of selling his wife verbally many times before. He has ‘talked this nonsense in public places before’ (p11), and Susan was willing to leave

‘provided she can have the child’ (p14). Michael announces it publicly in the inn:

“She said so only the other day when I talked o’it.” (Hardy 12)

Susan confirms it by saying

“I do” (Hardy p12)

But the verbal announcement and the confirmation of it when carried to the extremes, Susan says:

“Mike....I’ve lived with thee a couple of years, and had nothing but temper. No, I’m no more to ‘ee. I’ll try my luck elsewhere.” (Hardy 13) and she goes away with her daughter. Susan is apparently commodified here, but Susan's speech carries a stamp of her anguish against the treatment she received from Henchard. This can be seen as a beginning point of the novel.

Talking about Henchard's character Ian Gregor in ‘The Great web: The Form of Hardy's Fiction (1974) remarks “He (Henchard) affects the life of other characters is in making us feel they are never allowed to live and breathe apart from him” (115)

It is important to see this idea from different perspective too. Henchard is also affected by the other characters in the novel. If we note the kind of complaints that Henchard makes on several occasions. We may get a glimpse of the point I am trying to make here:

Talking to Farfrae about his mental space, he says:

“I’m a lonely man, Farfrae:

I have nobody else to speak to...” (Hardy 75)

and on a different occasion he says:

“I sank into one of those gloomy fits I sometimes suffer from, on account o’ the loneliness of my domestic life” (Hardy 76)

Echoes of such complaints run throughout the novel. We find that one of the important factors of Henchard's life is his loneliness. The point I am trying to raise is what makes Henchard to complain about his loneliness even after Susan returns with Elizabeth Jane? Or After Susan's death, Lucetta arrives at Casterbridge to marry Henchard? Why could not Henchard recover from his loneliness?

Let me begin from the moment when Susan returns with her grown up daughter Elizabeth Jane. This Susan who comes after a long gap of 18 years is a different Susan. She is no more that Susan who somewhat excitedly left Henchard 18 years ago because of his senseless announcement of selling her. She is now endowed with a personal will, feelings and aspirations. On her first meeting with Henchard right after her arrival, she says:



“O Michael!... I meet you now only as his widow. I consider myself that, and that I have no claim upon you. Had he not died I should never have come---never! Of that you may be sure.” (Hardy 71)

Her self-assertion is very remarkable. It tells so much about the changed and confident Susan. At the same time, the implicit sense of detachment that she creates between herself and Henchard that she is no more dependent on anybody even after Newson's death is mistaken by Henchard. He says:

“It's only that which makes me feel'ee an innocent woman.”(Hardy 71)

But Susan is not that innocent woman who let her husband to sell her. She is different now who goes on asserting her new strength that she has gained over the years. She also gained enough experiences to realize the attempt of intimacy shown by Henchard. She separates herself from that and says that she came to see Henchard and that she will go away with her daughter at once if he wants them to. Here we must remember that Susan's primary aim was to secure a safe shelter for her daughter and herself, and she was aware of Henchard's emotions and impulsive nature very well. Henchard, by now, recognized the new confidence in Susan. He replies to her:

“No, no Susan, you are not to go... I have thought of this plan that you and Elizabeth take a cottage in the town...that I meet you, court you and marry you..and I should have the pleasure of seeing my only child under my roof as well as my wife.” (Hardy 71)

Once she becomes assured of Henchard's politeness, then only she reveals her intention of coming to Casterbridge. She tells Henchard:

“I come here only for the sake of Elizabeth, for myself, if you tell me to leave again tomorrow morning, and never come near you more. I am content to go” (Hardy 72)

Henchard doesn't want her to go away and thus Susan secures her daughter first and then herself in the hands Henchard. Dale Kramer, in his “Thomas Hardy: The Forms of Tragedy”, discusses this turn of events from Henchard's perspective. He suggests that Henchard remarries Susan not for renewed love but because of a sense of obligation, duty and rightness. Kramer may be right in his observation, but it is also important to explore the nature of obligation and rightness on the other side, that is on the side of Susan. Susan admits that she had entered the situation solely for the sake of her daughter's reputation. She expresses her indifference to Henchard although implicitly. Henchard, on the other hand, has to bow down or come to a certain sort of compromise leaving his “rule o' thumb” (Hardy 50) status.

It is also interesting to know how Elizabeth becomes the central point of Henchard's and Susan's discussion. All precautions are taken by Henchard and Susan so that her sentiments remain unhurt. The public auctioning of Susan has now become a private matter. Henchard fights hard to keep it a secret. This becomes a responsibility on Henchard. The creation of such sensibility in Henchard is a sole credit of Susan. It is she who sows the responsibility in Henchard and keeps it alive in him through her speeches. But this sense she creates in him seems to be enveloped with a kind of selfishness which is carried to a certain extreme where Henchard's emotional need is completely forgotten. Henchard receives no or little response from Susan, except the fatal lie that Elizabeth is not his daughter,

but of Newson. But, there is no denying to the fact that Susan's primary concern was the safe future of her daughter, and moreover, we must admit that she was honest in her confession, although she deliberately reveals it late to Henchard because she wanted no harm to the sentiments and feelings of either of them.

The character of Elizabeth Jane, as Hardy describes her, is something of a prig concerned with respectability from her first appearance. When Susan appears in the scene with her daughter and goes to the furnity-woman to enquire about her past incident, Elizabeth Jane says:

“Don't speak to her—it isn't respectable” (Hardy 21) and again while getting out of the fair she remarks:

“mother ... it was hardly respectable for you to buy refreshments there, I see none but the lowest do.” (Hardy 23)

However, when later they reunite with Henchard, we are told that to Elizabeth Jane, that time was the most triumphant one. “The freedom she experienced, the indulgence with which she was treated went beyond her expectation” (Hardy 84). But Susan could not feel completely secured about her daughter's position in the hands of Henchard. So she was searching for an alternative. She found it in Donald Farfrae. She secretly writes a note to Elizabeth Jane and Donald to unite them together in Durnover Barton. Susan wanted Elizabeth Jane to marry Donald Farfrae.

Susan was partially correct in foreseeing this, because after discovering the secret of Elizabeth's fatherhood, Henchard turned indifferent and harsh toward Elizabeth Jane. Although she is not subjected to the public ridicule and mistreatment to the same extent as Lucetta; but Henchard here appears to be the main instigator of her worries. From the very beginning of Henchard's remarriage, he expects Elizabeth to behave like the daughter of a Mayor. He finds her style of handwriting not up to the mark. He assumes that since Elizabeth Jane is a female, she should write ladies'—hand. Eventually, we find that Henchard's attitude toward Elizabeth changes her. She finds solace in Lucetta Templeman, because she thinks that if she stays with Lucetta, she can enjoy the kind of freedom she craves for. She accepts Lucetta's invitation and goes to her house. She affirms her individuality when she says:

“I would do anything to be independent” (Hardy 135)

It is true that in some respect Hardy has portrayed these women characters as typical examples of women of his time, but it is interesting to see how within these conventions, he allowed his characters to display their personality against some of his norms of institutional attachments. Hardy does this by keeping Henchard fixed, in whom old values remain unchanged and the mobile characters like Susan, Elizabeth, Lucetta whose attitudes change continually towards him.

It has been argued that everyone goes away from Henchard because of his own fault or his misfortune. This is true to some extent, because right from the beginning of the novel, Henchard is shown as impulsive and inconsistent, but this impulsiveness and inconsistency clashes with Lucetta who is presented as a very ambitious woman. As she comes to know that Henchard is going to remarry Susan, she wants those letters back which she had written to him in the heat of feelings when they were in love. She considers these letters as a safeguard to make any future happiness possible to her own self. But, again, when she learns that Susan is dead, she comes to Casterbridge in order to marry



Henchard. But Lucetta, too, like Susan, has undergone a change now. She has inherited a large property from her recently deceased aunt. She is now her own mistress. This economic independence gives her a courage to alter her choice from Henchard, whom she now considers as 'hot tempered and stern' (p178) and she also thinks that it would be madness to bind herself to him. She says:

"I won't be a slave to the past—I'll love where I choose!" (Hardy 173)

But Henchard could not accept her changed attitude. He gets furious and threatens to reveal her in front of everyone, and eventually, we see her destruction, although this was not done by Henchard willingly. Talking about Lucetta's tragic end many critics observed that it was primarily Lucetta's attempt to break from the bonds of her past, and this destroys her and the attitudes of society towards her.

She could recognize the change in her which is largely because of the economic independency. She explains her situation to Henchard after she inherits the fortune:

"I was a poor girl then now my circumstances have altered so I am hardly the same person" (Hardy 191) and also because she could realize what it means to be Henchard's wife now. She says:

"Had I found that you proposed to marry me for pure love I might have felt bound now. But I soon learnt that you had planned it out of mere charity—almost as an unpleasant duty – After that I did not care for you, so deeply as before." (Hardy 191)

This shows how clearly she understands the terms of marriage. Her selection is based not on emotions but on strong judgments. It is another matter that her intimacy with Henchard, when revealed in Casterbridge, leads to her social downfall, a miscarriage and subsequently, her death.

We may take a note of Hardy's comment on "The Mayor of Casterbridge" which he made on January 2, 1886, the day when the novel began in the 'Graphic newspaper', and 'Harper's Weekly':

"..after all it is not the improbabilities of the incidents but the improbabilities of the characters that matter" (Nemesvari 60) But we find that the improbabilities in the women characters are equally evident as in the character of Henchard. In "The Mayor of Casterbridge", Thomas Hardy attempts to make Victorian society more aware of its treatment and attitude towards women and he has successfully affected this objective through the chief female characters---Susan, Elizabeth and Lucetta to a great extent. Thus by giving the place and situation, Hardy allows them the freedom and strength to display their personal feelings, to secure themselves, and to make their own choices within the Victorian conventions.

## II. CONCLUSION

Hardy, by giving the place and situation, allows them the freedom and strength to display their personal feelings, to secure themselves, and to make their own choices within the Victorian conventions. Henchard is depicted as an embodiment of traditional values and traditional man of Victorian society and he is very distinctly put against the chief female characters that represent the possibilities for women in Victorian society. The

transition of the female characters from simple everyday characters of Victorian period to self conscious and responsive women shows that Hardy was aware of the shifting world- a world that was processing elements of both the Victorian and modern times. The search for an ideal relationship which was so common during Victorian age is overtly redefined from a new perspective through the major female characters.

## REFERENCES

- [1] Abrams, Lynn. "Ideals of Womanhood in Victorian Britain." BBC. 18 Sept. 2014. Web. 21 Nov. 2014. Online.
- [2] Allingham, D. Elisabeth. "The Social Role and Treatment of Women in Thomas Hardy's The Mayor of Casterbridge." The Victorian Web. 17 Sep. 2003. Web. 18 Nov. 2014. Online.
- [3] Gregor, Ian. *The Great Web: The form of Hardy's Major Fiction*. London: Faber and Faber, 1974. Printed.
- [4] Hardy, Thomas. "The Mayor of Casterbridge". Feedbooks. 10 Aug. 2012. Web. 19 Sep. 2014. Online.
- [5] Hornback, Bert G. *The Metaphor of Chance: Vision and Technique in the Works of Thomas Hardy*. Athens Ohio: Ohio University Press, 1971. Printed.
- [6] Kramer, Dale. *Thomas Hardy: The Forms of Tragedy*. London and Basingstoke: Macmillan, 1975. Printed.
- [7] Morgan, Rosemarie. *Women and Sexuality in the novels of Thomas Hardy*. London and New York: Routledge, 1988. Printed.
- [8] Nemesvari, Richard. *Thomas Hardy, Sensationalism and the Melodramatic Mode*. New York: Palgrave Macmillan, 2011. Printed.

## AUTHORS

**First Author** – Tazir Hussain, Badarpur, Assam, India

# DIGITAL ATTENDANCE CALCULATION SYSTEM USING SUPPORT VECTOR MACHINE & IMAGE PROCESSING

RAJIB BAG, GAUTAM, KOMAL DAS, P. MOHINI AMMA

Computer Science & Engineering  
Dr. B.R. Ambedkar Institute of Technology  
Port Blair, Andaman & Nicobar Island, INDIA

**Abstract**— This paper deals with recognizing and classifying handwritten characters and classifies it with respect to other characters in the method for attendance calculation system. Existing system of calculation of attendance contains manual calculation for the number of students present or absent in a class. In this paper we proposed a digitized method for calculating number of classes present and absent for a student which in the previous case is time consuming and may sometimes produce incorrect result in some cases. It uses features of a character extracted using feature extraction techniques. There are methods been proposed for feature extraction that can be simulated using support vector machine for further calculation of the attendance using the attendance register. Support vector machine is one of the techniques that are used to classify a handwritten character based on handwriting recognition and identify the digitized output Support vector machine classifies a character by using a large number of training set that needs to be fed into the database for the accurate output.

**Key words**—*Support Vector Machine, Image Processing, Feature Extraction, Attendance Calculation System*

## Introduction

In the world, where everything has been digitized, using computer based algorithms and various coding and decoding techniques, data is processed with the help of programs and we get the desired output. Identification of objects in a real world plays a key role for human-computer interaction in a computer-augmented environment using augmented reality techniques. There are two characters used in this application. The main aim of this paper is to present an application using support vector machine that calculates the consolidated attendance of each student by the image of attendance register. This

application has been developed using steps including pre-processing for image acquisition, feature extraction to extract the features from an acquired image and Support Vector Machine where these features are used to train a SVM classifier with different samples and a training set is developed. The extracted features is used to form a training set for Support Vector Machine, a test sample is checked to illustrate that whether a sample belongs to the class or not. Whenever a new character either P or A is given to the system it forms a testing set and classifies whether the character is P or A. The total number of P and A are calculated for each row.

## Preprocessing

### A. CONVERSION OF RGB TO BINARY

Binarization[8] is one of the most important techniques for preprocessing stage. Among many binarization techniques, the Otsu's method is considered as the most commonly-use done in the survey papers. If a pixel is greater than or equal to the threshold intensity, the resulting pixel is white ("0"). On the other hand, if a pixel in the image has intensity less than the threshold value, the resulting pixel is black ("1"). Binarization[8] of image consists of that either global or local threshold. Global thresholding has a good performance in the case that there is a good separation between the foreground and the background.

Otsu's global threshold method finds the global threshold  $t$  that minimizes the intra-class variance of the resulting black and white pixels. Then the binarization is formed by the setting

$$b_i = 1 \text{ if } x_i < t \text{ and } b_i = 0 \text{ if } x_i > t$$

Unlike global approaches, local area information may guide the threshold value for each pixel in local (adaptive) thresholding techniques. A local

algorithm is introduced in that calculates a Pixel-wise threshold by shifting a rectangular window across the image.

The threshold  $T$  for the center pixel of the window is computed using the mean  $m$  and the variance  $s$  of the gray values in the window:

$$T = m + ks$$

Where  $k$  is a constant set to -0.2. The value of  $k$  is used to determine how much of the total print of object boundary is taken as a part of the given object.

### B. MEDIAN FILTERS

The median  $m$  of a set of values is the value that possesses the property that half the values in the set are less than  $m$  and half are greater than  $m$ . Median filtering is the operation that replaces each pixel by the median of the grey level in the neighborhood of that pixel.

Median filters[8] are nonlinear filters because for two sequences  $x(n)$  and  $y(n)$

$$\text{median}\{x(n) + y(n)\} \neq \text{median}\{x(n)\} + \text{median}\{y(n)\}$$

Median filters[8] are useful for removing isolated lines or points (pixels) while preserving spatial resolutions. They perform very well on images containing binary (salt and pepper) noise but perform poorly when the noise is Gaussian.

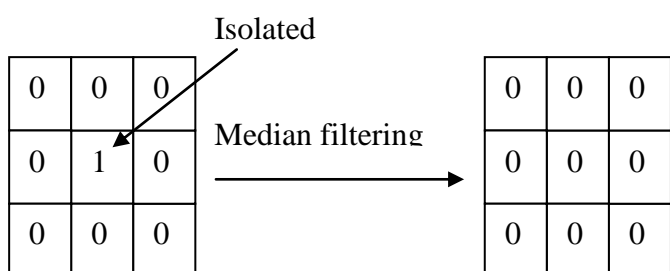
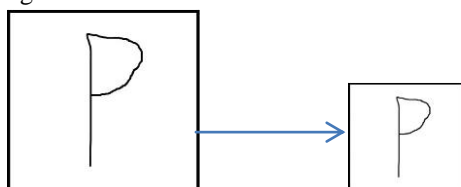


Fig 1 Median Filter

### C. RESIZING

Resizing[8] an image is defined as reducing or enlarging dimensions of an image. The resizing is usually done described given below:



400 x 400

32 x 32

Fig 2 Image resizing

### D. THINNING

Thinning [8] is an important preprocessing step in optical character recognition. The purpose of thinning is to delete redundant information and at the same time retain the characteristic features of the image. In order to reduce the quantity of information minimally, a thinning algorithm play an important role in recognition of the character, figure, and drawing.

Thinning [8] is usually involves removing points or layers of outline from a pattern until all the lines or curves are of unit width, or a single pixel wide. The result in set of lines or curves is called the skeleton of the object as shown in figure.

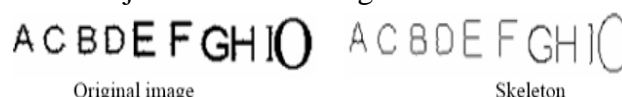


Figure 3: Skeleton produced by thinning process

### EXISTING FEATURE EXTRACTION TECHNIQUES

#### A. FREEMAN CHAIN CODE

The main objective of feature extraction is to remove redundancy from data. The task of human expert is to select features that allow effective and efficient recognition of pattern. The architecture of recognition system

Feature extraction is a very important in recognition system because it is used by the classifier to classify the data. Chain code is one of the representation techniques that is useful for image processing, shape analysis and pattern recognition fields. Chain code representation gives the boundary of character image in which the codes represent the direction of where is the location of the next pixel. The first approach of chain code was introduced by Freeman in 1961 that is known as Freeman Chain Code (FCC)[16]. There are two directions of chain code, namely 4-neighborhood and 8-neighborhood.

#### B. CAEMASTRA TECHNIQUE

The present feature extraction[7] works on global and local features. The global feature includes the analysis of pattern with respect to baseline and

width/height ratio. The local features divides the character by dividing into 4 x 4 grid and calculating the number of pixels horizontally and vertically along each column at regular pixels. A probability of number of pixels in the grid with respect to the number of pixels found by the same method with the whole image. If  $n_i$  is the number of foreground pixels in cell  $i$  and  $M$  is the total number of foreground pixels in the pattern, then the gray feature related to cell  $i$  is  $n_i/M$ . The other operators try to estimate to which extent the black pixels in the cell are aligned along some directions. For each direction of interest, a set of  $N$ , equally spaced, straight lines are defined, that span the whole cell and that are parallel to the chosen direction. Along each line  $j \in [1, N]$  the number  $n_j$  of black pixels is computed and the sum  $\sum_{j=1}^N n_j^2$  is then obtained for each direction. The first global feature measures the fraction of the character below the baseline and detects eventual descenders. The second feature is the width/height ratio. The number of local features can be arbitrarily determined by changing the number of cells or directions examined in each cell. Therefore the feature set was tested changing the number of cells and the grid giving the best results ( $4 \times 4$ ) was selected. A feature vector of 34 elements was formed. Two features are global (baseline and width/height ratio) while the remaining 32 are generated from 16 cells, placed on a regular  $4 \times 4$  grid from each cell.

### SUPPORT VECTOR MACHINE

Although there are several other algorithms [12][13][14] as pattern classifiers, Support Vector Machine (SVM) [2][3][4][7][16] is an algorithm that is widely used among them, after projecting data in the Feature space, computes an Optimal Separating Hyper plane, based on Statistical Learning Theory [5][13].

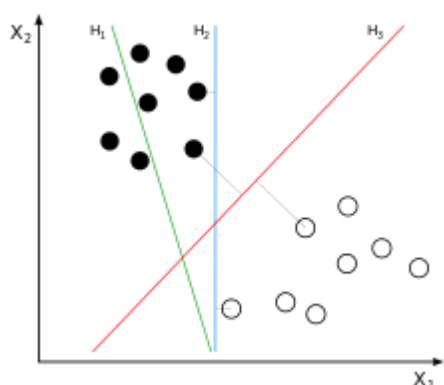


Fig 4. H2 provides the maximum margin hyperplane between two classes

### A. LINEAR CLASSIFICATION USING SVM:

#### OPTIMAL SEPARATING HYPERPLANE:

We are given a set  $D$  of patterns  $x_i \in R^n$  with  $i = 1 \dots l$ . each pattern  $x_i$  belongs to either of two classes  $y_i \in \{-1, +1\}$ . The patterns with output  $+1$  are called positive patterns, while the others are called negative patterns. The goal is to establish the equation

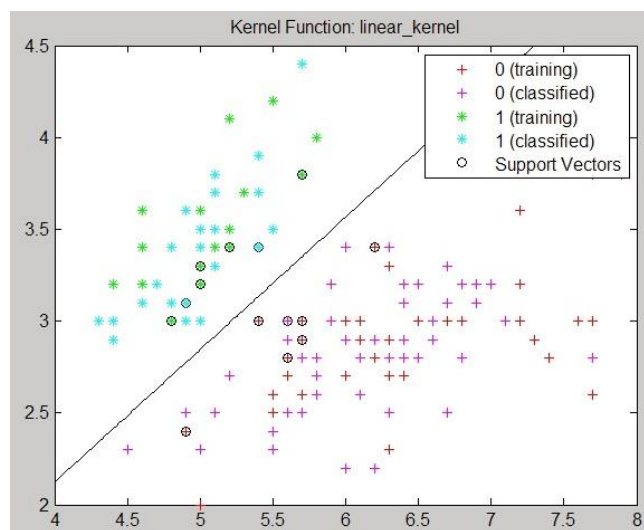


Fig 5. A linear SVM that separates two classes by a maximum margin hyperplane

$$w \cdot x + b \quad (w, x \in R^n, \quad b \in R)$$

of the Optimal Hyper plane that divides  $D$  leaving all points of the same class on the same side while maximizing the distance between the two classes and the hyper plane. This can be expressed by the constraints:

$$y_i(w \cdot x_i + b) > 1, \quad i = 1, \dots, l$$

In most practical problems a separating hyper plane may not exist. Due to presence of noise, an overlapping between classes may exist. Hence it has to allow that the constraints can be violated by some examples

Using slack variables  $\epsilon > 0$  the constraints can be relaxed in:

$$y_i(w \cdot x_i + b) \geq 1 - \epsilon_i, \quad i = 1, \dots, l$$



Therefore we can construct a classifier, Support Vector Machine solving the following optimization problem

$$\begin{aligned}
 & \text{minimize} \\
 & \frac{1}{2}\|\mathbf{w}\|^2 + C \sum_{i=1}^l \xi_i \\
 & \text{subject to} \quad y_i (\mathbf{w} \cdot \mathbf{x}_i + b) \geq 1 - \xi_i, \quad i = 1, \dots, l \\
 & \quad \xi_i > 0, \quad i = 1, \dots, l
 \end{aligned}$$

The classifier controls at the same time the margin  $\|\mathbf{w}\|$  and the number of training errors. The regularization constant  $C > 0$  determines the trade-off between the two terms. The conditional optimization problem can be solved by introducing Lagrange multipliers  $\xi_i > 0$  and a Lagrangian function

$$\min_{\mathbf{w}, b} \max_{\alpha_i \geq 0} \left\{ \frac{1}{2} \|\mathbf{w}\|^2 - \sum_{i=1}^n \alpha_i [y_i (\mathbf{w} \cdot \mathbf{x}_i + b) - 1] \right\}$$

The Lagrangian  $L$  has to be minimized with respect to the *primal variables*  $w$  and  $b$  and maximized with respect to the *dual variables*  $i$ , i.e. a saddle point has to be found. The condition at the saddle point implies that the derivatives of  $L$  with respect to the primal variables must vanish

#### 4.2. NON-LINEAR CLASSIFICATION USING SVM:

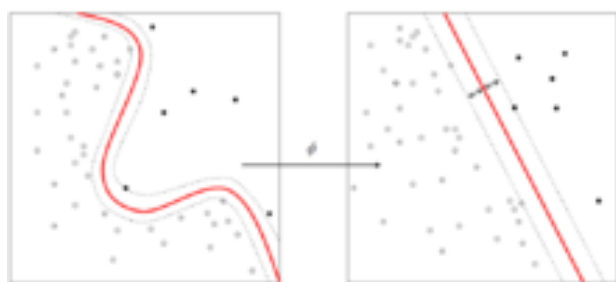


Fig 6. A nonlinear classification by using Kernel Functions

The original optimal hyper plane algorithm proposed by Vapnik in 1963 was a linear classifier. However, in 1992, Bernhard E. Boser, Isabelle M. Guyon and Vladimir N. Vapnik suggested a way to create nonlinear classifiers by applying the kernel trick (originally proposed by Aizerman et al.) to maximum-margin hyperplanes. The resulting

algorithm is formally similar, except that every dot product is replaced by a nonlinear kernel function.

If the kernel used is a Gaussian radial basis function, the corresponding feature space is a Hilbert space of infinite dimensions. Maximum margin classifiers are well regularized, so the infinite dimensions do not spoil the results.

Some of the common kernel functions [6][10][15] include:

1. Polynomial(homogeneous):  $k(\mathbf{x}_i, \mathbf{x}_j) = (\mathbf{x}_i \cdot \mathbf{x}_j)^d$
2. Polynomial(inhomogeneous):  $k(\mathbf{x}_i, \mathbf{x}_j) = (\mathbf{x}_i \cdot \mathbf{x}_j + 1)^d$
3. Gaussian radial basis function:  $k(\mathbf{x}_i, \mathbf{x}_j) = \exp(-\gamma \|\mathbf{x}_i - \mathbf{x}_j\|^2)$  for  $\gamma > 0$ .  
Sometimes parameterized using  $\gamma = 1/2\sigma^2$
4. Hyperbolic tangent:  $k(\mathbf{x}_i, \mathbf{x}_j) = \tanh(\kappa \mathbf{x}_i \cdot \mathbf{x}_j + c)$ , for some  $\kappa > 0$  and  $c > 0$ .

### B. MULTICLASS SVM:

In order to use SVM when the number of classes  $K$  is larger than 2, a few different strategies have been suggested. In our experiments we have adopted *One-versus-rest (o-v-r)* method. The method learns one classifier for each of the  $K$  classes against all the other classes. More formally, the method consists in training  $K$  SVM classifiers  $f_j$  by labeling all training points having  $y_i = j$  with  $+1$  and  $y_i \neq j$  with  $-1$  during the training of the  $j$ th classifier. In the test stage, the final decision function  $F(\phi)$  is given by:

$$F(x) = \text{arg max}(f_j(x))$$

### PROPOSED METHODS

#### A. DISTANCE MEAN FEATURE EXTRACTION

There are various feature extraction techniques as given in [1][2][3][4][7]. The algorithm takes mean from all the sides by the distance from the first element pixel to the first black pixel in the row. The features are calculated as per the dimensions given below as four features gives four dimensions in an



image. There are four features extracted from the character which are calculated as below:

Extracted distance from left to right

$$a = \frac{1}{n} \sum_{i=1}^n a_i$$

Extracted distance from left to right

$$b = \frac{1}{n} \sum_{i=1}^n b_i$$

Extracted distance from left to right

$$c = \frac{1}{n} \sum_{i=1}^n c_i$$

Extracted distance from left to right

$$d = \frac{1}{n} \sum_{i=1}^n d_i$$

These four features extracted are given as parameters to Support Vector Machine for further simulation.

### B. FUDICIAL POINTS FEATURE EXTRACTION

The yet another technique for feature extraction is quiet simplified as it works for only P and A as the features is as per two characters. The features of the character are taken as per below:

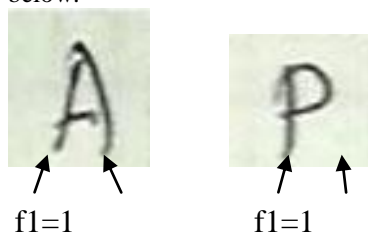


Fig 7. Fudicial Point Feature Extraction

1. The algorithm works as follows:

1. Start scanning from left bottom corner of the image.
2. If a black pixel  $A[i][j] \neq 1$  is found along the row then iterate  $i=i+1$  and scan next row until  $A[i][j]=1$  is found or  $f1=1$ .
3. If a black pixel  $A[i][j]=1$  is found along horizontal scanning assign  $f1=1$  and search for  $f2=1$  in the same row.
  - a. If  $f2=1$  in the same row then assign features as 1 and 1.
  - b. If  $f2=0$  along the same row, then scan for the next 5 rows with iterations and search for  $f2=1$  as given in the above figure, if not found assign  $f2=0$ .
4. Note the features  $f1$  and  $f2$  as parameter to Support Vector Machine.

2. Pseudocode

1. Algorithm FeatureExtraction(I2)

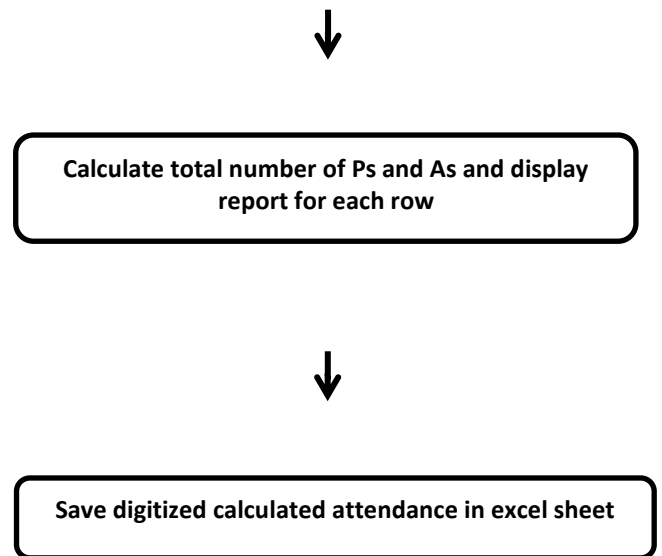
```

2. {
3. s:=size(I2);
4. f1:=0;
5. f2:=0;
6. row:=s(1);
7. while(row>0)
8. {
9. for col=1 to s[2]
10. {
11. x:=I2[row,col];
12. if(x==0)
13. {
14. f1:=1;
15. break;
16. }
17. }
18. if(f1==1)
19. {
20. break;
21. }
22. row:=row-1;
23. }
24. for c=col+10: to s[2]
25. {
26. y:=I2[row,c];
27. if(y==0)
28. {
29. f2:=1;
30. break;
31. }
32. if(f2==1)
33. {
34. break;
35. }
36. }
37. if(f2~1)
38. {
39. r:=row-1;
40. while(r>=row-3)
41. {
42. for c=col+10 to s(2)
43. {
44. y1:=I2[r,c];
45. if(y1==0)
46. {
47. f2:=1;
48. break;
49. }
50. }
51. if(f2==1)
52. {
53. break;
54. }
55. r:=r-1;
56. }
57. }

```

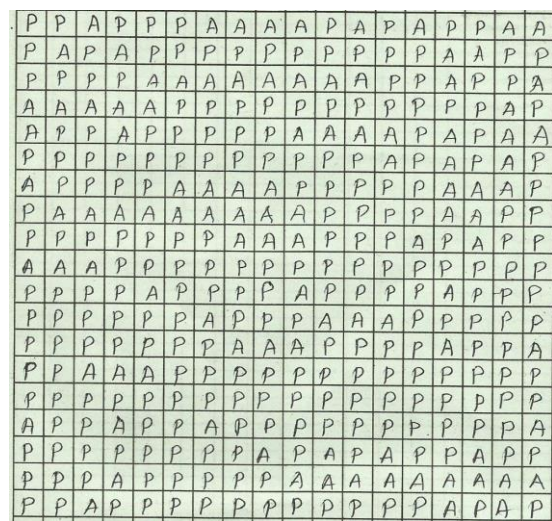
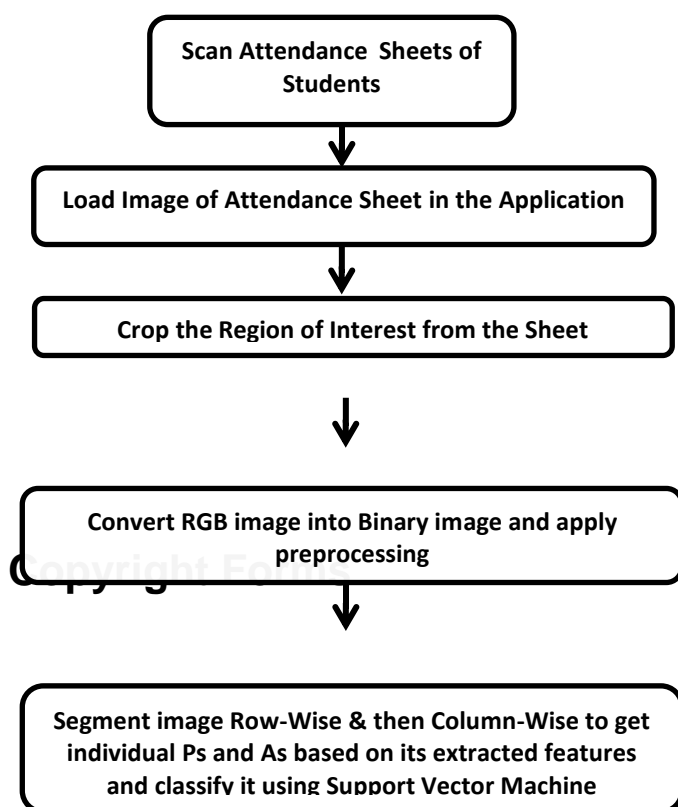
```

58.if(f2~=1)
59.{
60. r:=row-1;
61. while(r>=row-3)
62. {
63.   c:=col-10;
64.   while(c>0)
65.   {
66.     y1:=I2[r,c];
67.     if(y1==0)
68.     {
69.       f2:=1;
70.       break;
71.     }
72.     c:=c-1;
73.   }
74.   if(f2==1)
75.   {
76.     break;
77.   }
78.   r:=r-1;
79. }
80.}
81. A:=[f1;f2];
82. write f1,f2;
83.}
    
```



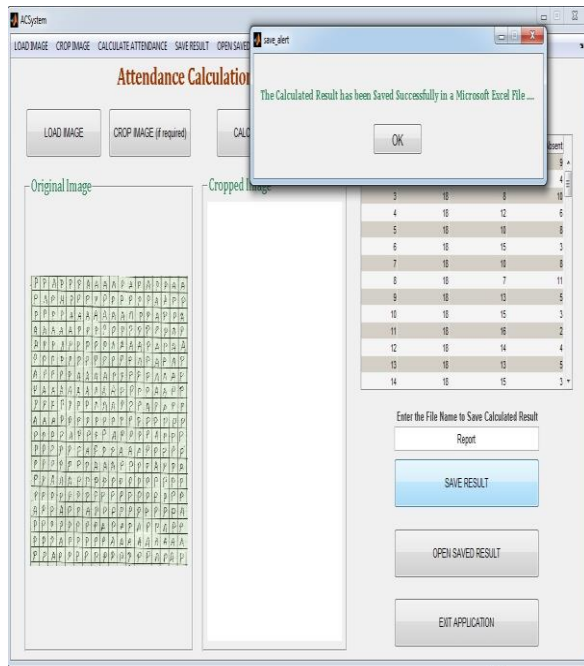
**Fig 8: Flowchart for application for attendance calculation system**

### V. ATTENDANCE CALCULATION SYSTEM



**Fig 9. Sample of a cropped region from an**

**Attendance sheet**



**Fig 10. Snapshot of the application**

**VI. TEST CASE AND RESULTS**

**A. PERFORMANCE EVALUATION**

Sl. No	Samples taken(120)	Image fed for testing	Number of images classified
1.	Sample 1	30	30
2.	Sample 2	30	30
3.	Sample 3	30	29
4.	Sample 4	30	29

**Table 1. Performance Evaluation (Fudicial Point Method)**

Sl. No	Samples taken(120)	Image fed for testing	Number of images classified
1.	Sample 1	30	30
2.	Sample 2	30	30
3.	Sample 3	30	28
4.	Sample 4	30	28

**Table 2. Performance Evaluation (Distance Mean Method)**

**VII. CORRECTNESS VERIFICATION**

The application is developed in MATLAB. The following are the accuracy results for the two methods in the analysis of the two proposed methods of feature extraction:

Sl. No	Name of the Proposed Method	No. of training Image	No of testing image	Accuracy rate
1.	Fudicial Point Feature Extraction	128	127	99.21%
2.	Distance Mean Feature Extraction	128	125	97.65%

**Table 3. Correctness Verification**

**IX. CONCLUSION AND FUTURE WORK**

This system proposes an algorithm that can achieve a task of scanning an attendance sheet that will speed up the process in the current system. This makes a manual work lot easier as user just need to scan an attendance register and calculation of attendance for each student will be done automatically. The simple user interface allows any user to easily operate the work. The user could also save the results for further work. The user could work easily using the system as this system is useful for the case where there are a large number of data available for calculation. The calculation time for support vector machine to identify is not too large as it uses only two characters for the classification of a character. There are a large number of data set available as a training set for accurate recognition of a character in support vector machine. This proposed system could reduce the work load of calculation of attendance from the attendance register.

There may be a mobile application which will capture attendance register and will produce the same result. This will be more easy of the calculation for a faculty. Moreover similar system can be developed for other languages as well.

**ACKNOWLEDGMENTS**

First of all we would like to thank the Almighty, who has always guided us to work on the right path of the life. Our greatest thanks are to our parents who bestowed ability and strength in our, to complete this work.

This work would not have been possible without the encouragement of principal, Dr.B.R.Ambedkar Institute of technology, PortBlair. His enthusiasm and optimism made this experience both rewarding and enjoyable.

We are equally grateful to HOD,C.S.E, Dr.B.R.Ambedkar Institute of technology, PortBlair who always encouraged us to keep going with work and always advised with his invaluable suggestions. We would like to express our sincere gratitude towards, entire faculty and staff members of Dr. B.R.Ambedkar Institute of Technology, PortBlair for their direct-indirect help, cooperation, love and affection for completion this work.

## REFERENCES

- [1]. R. Plamondon, S. Srihari, On-line and off-line handwriting recognition: a comprehensive survey, IEEE Trans. Pattern Anal. Mach. Intell. (2000) 63–84.
- [2]. A. Senior, A. Robinson, An off-line cursive handwriting recognition system, IEEE Trans. Pattern Anal. Mach. Intell. 20 (3) (1998) 309–321.
- [3]. G. Kim, V. Govindaraju, A lexicon driven approach to handwritten word recognition for real time applications, IEEE Trans. Pattern Anal. Mach. Intell. 19 (4) (1997) 366–379.
- [4]. R. Bozinovic, S. Srihari, Off-line cursive script word recognition, IEEE Trans. Pattern Anal. Mach. Intell. 11 (1) (1989) 69–83.
- [5]. V. Vapnik, Statistical Learning Theory, Wiley, New York, 1998.
- [6]. J. Shawe-Taylor, N. Cristianini, Kernels Methods for Pattern Analysis, Cambridge University Press, Cambridge, 2004.
- [7]. F. Camastra, “A SVM-based cursive character recognizer,” in Pattern Recognition, vol. 40, pp. 3721-3727, March 2007.
- [8]. J. R. Parker, Algorithms for Image Processing and Computer Vision, John Wiley and Sons, 1997.
- [9]. Mathworks Matlab™ – The language of technical computing. Link: <http://www.mathworks.com/products/matlab/>
- [10]. SINGIRESU S. RAO, “Engineering Optimization”, A Wiley -Interscience Publication John Wiley & Sons, Inc.
- [11]. Cleber Zanchettin, Byron Leite Dantas Bezerra and Washington W. Azevedo, “A KNN-SVM Hybrid Model for Cursive Handwriting Recognition”, WCCI 2012 IEEE World Congress on Computational Intelligence June, 10-15, 2012 - Brisbane, Australia.
- [12]. Duda, Hart, and Stork, "Pattern classification" Chapter 5, Wiley, 2000.
- [13]. Vapnik V. N. “An overview of statistical learning theory”, IEEE Trans. on Neural Networks, 10(5):988–999, 1999.
- [14]. Haykin, S. “Neural networks - a comprehensive foundation”, Prentice Hall, 1996.
- [15]. J. Smola and B. Schölkopf. Learning with Kernels. The MIT Press, Cambridge, MA, 2002.

**Correspondence Author – Rajib Bag,**  
[bag.rajib@gmail.com](mailto:bag.rajib@gmail.com) .

[16] R.Aruna devi, S.Latha, K.Vidhya, "Handwritten Character Recognition Using Based Segmentation And Support Vector Machine Classifier" IJART, Vol. 2 Issue 1, 2012."

#### AUTHORS

**First Author** – Rajib Bag, M.Tech, DBRAIT and [bag.rajib@gmail.com](mailto:bag.rajib@gmail.com)

**Second Author** – Gautam, qualifications, DBRAIT and [gs0811@gmail.com](mailto:gs0811@gmail.com).

**Third Author** – Komal Das, B.Tech, DBRAIT and [komal.das12990@gmail.com](mailto:komal.das12990@gmail.com)

**Fourth Author** – P. Mohini Amma, B.Tech, DBRAIT and [mohiniexpo@gmail.com](mailto:mohiniexpo@gmail.com)



# Closed loop traffic signal controller

Reshmi Banerjee

Electrical Engineering Department, Guru Nanak Institute of Technology

**Abstract-** In our daily life traffic signal controller plays a vital role in channeling the vehicles from one corner of the city to the other. This system not only maintains a systematic approach in terms of “vehicle management” but also reduces accidents and rushes in peak hours. The disadvantage of open loop system is poor “time management”. So the poor time management of open loop system is rectified by closed loop system, keeping in mind both efficiency and cost of the system.

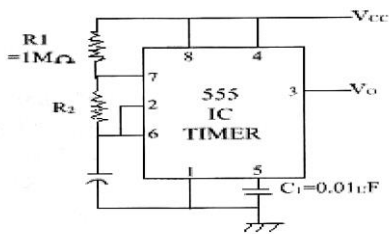
**Index Terms-** Closed loop system, Open loop, Time management, Traffic signal controller.

## I. INTRODUCTION

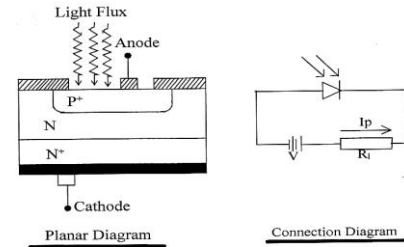
In today’s world time is very - very important and often in open loop system we lose much of our precious time. Suppose a road is programmed to be open for 1 minute and it is seen that after the initial passing of vehicles for 10 seconds there is no other vehicle within 20 meters mark. As a result of which when the next vehicle comes, we have already lost important time.

Benefits of traffic signal controller : i) Increasing the traffic handling capacity of roads. ii) Reducing collisions, both vehicular and pedestrian. Encourages travel within the speed limit to meet green lights. iii) Reducing unnecessary stopping and starting of traffic – this in turn reduces fuel consumption, air pollution, noise and vehicle wear and tear. iv) Improve journey time. v) Reducing driver frustration and ‘road rage’.

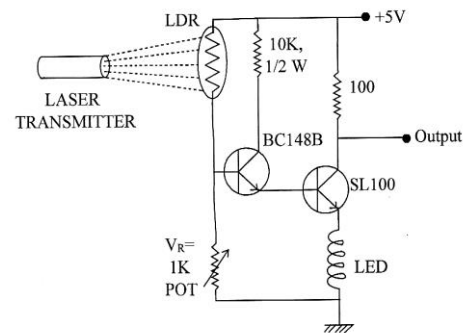
The IC555 timer in astable mode is used here for developing the 60 seconds and 8 seconds delay. The basic block diagram is given below:



LDR depends for its operation on the inner photoelectric effect. The incident light controls the reverse current of a photodiode.

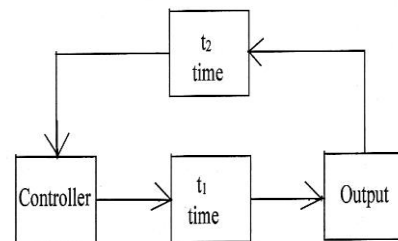


The laser receiver consists of a darlington pair, a LDR, a variable resistance and a fixed resistance.

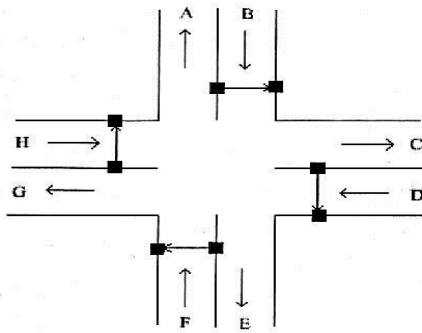


**Research Elaborations** – The basic idea behind closed loop system is efficient time management in addition to good vehicle management. In open loop system there was no feedback for determining the density of vehicle; this major drawback is eliminated in design of closed loop system.

Here the control mechanism will open a specific sequence of road for suppose  $t_1$  time. Within this  $t_1$  time we will be receiving a signal from the road depending on vehicle density. Whenever the density is low / nil and the signal is fed back to the controller for a time  $t_2$  ( $t_2 << t_1$ ), it will automatically change to the next sequence of traffic control. Thus efficient time management is achieved by closed loop system.



We are using laser mechanism for presence / absence of vehicle at the junction of roads. The following figure will simplify the idea :



Here only four lanes B, D, F and H are responsible for release of vehicles, so we are placing laser mechanism at the head of each lane. Whenever there is a car at the head of these lanes, the laser beam will be obstructed and digitally this is 0. Whenever the laser beam falls on the receiver it is 1 giving the idea that the immediate vehicle is behind the laser mechanism.

Then the problem arises, how to determine the density of road? Since when laser receiver is 1 it implies the immediate vehicle is behind the laser mechanism but the next problem is the distance between laser and immediate vehicle. For this we are using a delay, by that it is determined that the density on a road is high or low.

We are using the real time setting for the traffic signal controller. So whenever a road sequence starts it will primarily be opened for 1 minute (60 seconds). Again in order to determine the low density of a road we apply the idea that whenever the laser receiver is 1 and the immediate vehicle is behind 20 meters mark from the laser a second delay will complete its time period and eventually resets the first delay (60 seconds) and changes on to the next sequence. This action will stop the vehicle behind 20 meters mark from crossing the laser. We have seen practically that a vehicle crossing a four way junction of roads always keep the speedometer at 10 km per hour. So to cross a 20 meters mark a car requires round about 8 seconds. If we set the second delay at 8 seconds so that it can automatically stop the vehicles, which are behind the 20 meters mark.

Both the delays of 60 seconds and 8 seconds will work synchronously and each of them can change the sequence of roads whenever their cycle is completed. The general flow of traffic in all possible direction are shown below :

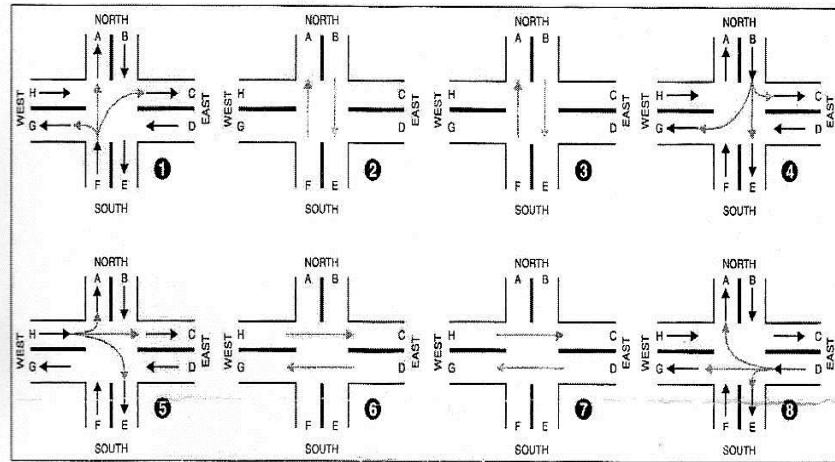
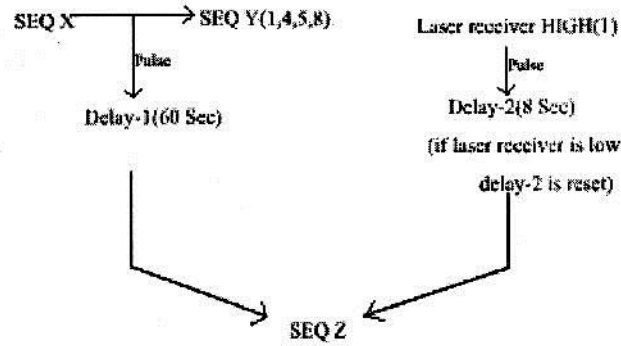


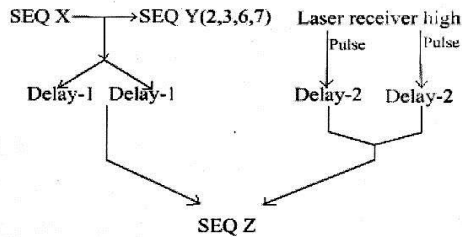
Fig. 1: Flow of traffic in all possible directions

For figure 1, 4, 5 and 8 the working of both the delays will follow the following chart :



(2,3,6,7)

For figure 2, 3, 6 and 7 as both roads are working simultaneously then the transition of sequence will occur if delay – 1 (60 seconds) has completed its cycle or delay – 2 (8 seconds) of both the roads have completed their cycles.



Here we are designing two delays (60 seconds and 8 seconds) with IC555 and couple it to the 3 – bit binary counter. But here a problem arises, how we are going to synchronize the delays? As for road sequence 1, 4, 5 and 8 both the delays are ORed i.e. whenever one delay completes its time period the 3-bit counter changes to the next state but when the road sequence 2, 3, 6 and 7 are in operation both the 8 seconds delays of two roads are ANDed i.e. they can change the sequence only when density of vehicle in both roads are low; the ANDed operation is finally ORed to the 60 seconds delay. Simply we can show :

$$\text{SEQUENCE} = \Rightarrow [\text{DELAY} - 1] \text{ OR } [\text{DELAY} - 2] \text{ (1,4,5,8)}$$

$$\text{SEQUENCE} = \Rightarrow [\text{DELAY} - 1] \text{ OR } [\text{DELAY} - 2 \text{ AND DELAY} - 2]$$

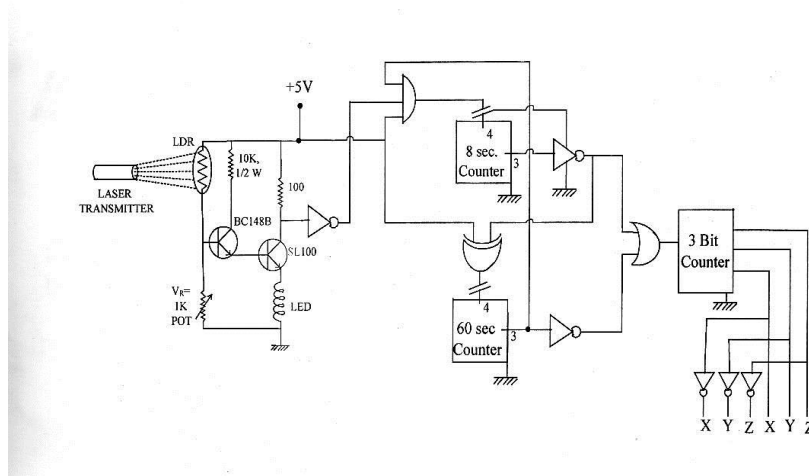
Here two delay – 2 are represented for road B and F (sequence 2,3) and D and H (sequence 6, 7).

For convenient operation we are ANDing the output of laser receiver of path B & F and also of path D & H. Again we are ANDing both the outputs of the previous two AND gates and the output of the 3<sup>rd</sup> AND gate is given to 8 seconds delay at pin 4 (reset pin). From pin 3 (output terminal) we give one input to a OR gate and the same input is being given to 60 seconds delay at pin 4 to reset it. Likewise from pin 3 of 60 seconds delay we give input to the OR gate and the same being given to pin 4 of 8 seconds delay. Thus 8 seconds delay will be reset whenever 60 seconds delay completes. The output of the OR gate is given to a 3 – bit binary counter which generates 8 states and works on the same principle as of a open loop system. For closed loop system both 8 seconds and 60 seconds delays are important, as whenever one completes its time period we will go to the next sequence. Both delays are reset the other one for a smooth operation. Here one important fact is that the 8 seconds delay forcefully changes the sequence when we are in a 60 seconds slot.

In laser operation for determining density of road one criterion to be fulfilled. The criterion is that when a certain road is closed, the first vehicle should stop behind the laser mechanism, which will be marked on the road. Thus, when a road is closed we will be “high” value from laser receiver and to AND gates. This satisfies the criteria that the road, which is open, can only trigger the 8 seconds delay when the laser receiver is “high” i.e. no vehicle.

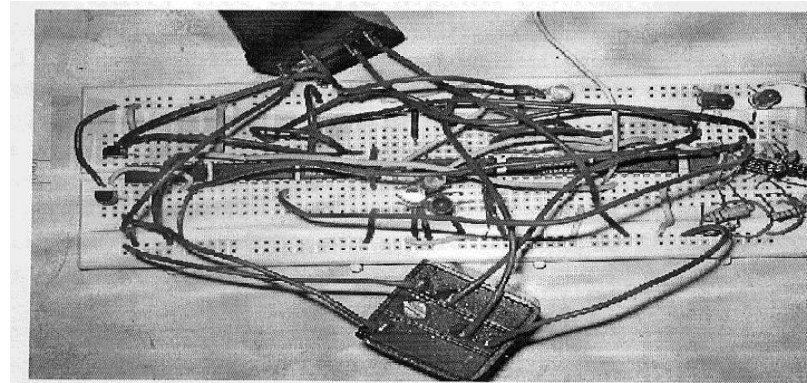
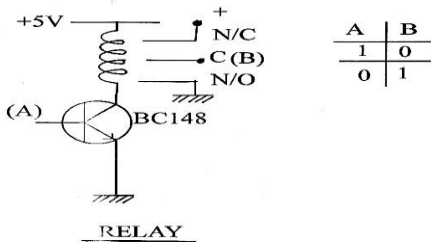






**Fig. 3 : Operation of 3 – bit binary counter**

For giving practical low and high values to pin 4 of both delays relays have been used, which are operated by a transistor. The relay operated as a NOT gate.



**Fig. 4 : Model of the Project**

Whenever a particular sequence (overall 8 sequence) of road opens, the 60 seconds delay starts on its own. If traffic density is high it will continue its time period upto 60 seconds and then gives a pulse to the 3-bit binary counter to change its state.

The roads which are closed will give a “high” output to the ANDed input terminal and the road/roads which are open will give a “low” output if density of road is high. When density of road is low it will give a “high” output and thus the ANDed combination will only work then and starts the 8 seconds delay. The 8 seconds delay can be reset whenever the output of the specific road is “low”.

For road sequence 2,3,6,7 both roads B & F and D & H will have to go through a dual checking of road density and only when both the laser output of the roads are “high”, then only 8 seconds delay will start.

8 seconds delay forcefully changes the 3-bit binary counter to change its state whenever the time period is complete.

Whether the 8 seconds or the 60 seconds delay has completed its time period it will change the 3-bit binary counter to next state and the same output will reset the other delay.

Both the delay output terminals are ORed and then given to the 3-bit binary counter.

The 3-bit binary counter works on the simultaneous states of signal as shown in table I, which are generated by a gated logic as shown in fig. by the Boolean function of table II.



TABLE I  
Simultaneous States of Signals for All the Traffic

X	Y	Z	B-C/B-G Lt/Rt	B-E St	D-E/D-A Lt/Rt	D-G St	F-G/F-C Lt/Rt	F-A St	H-A/H-E Lt/Rt	HC St	WALK (N-S)/(S-N)	WALK (E-W)/(W-E)
0	0	0	R	R	R	R	G	G	R	R	R	R
0	0	1	R	G	R	R	R	G	R	R	G	R
0	1	0	R	G	R	R	R	Y	R	R	G	R
0	1	1	G	Y	R	R	R	R	R	R	R	R
1	0	0	R	R	R	R	R	R	G	G	R	R
1	0	1	R	R	R	G	R	R	R	G	R	G
1	1	0	R	R	R	G	R	R	R	Y	R	G
1	1	1	R	R	G	Y	R	R	R	R	R	R

TABLE II  
Boolean Functions for All the Signal Conditions

Signal	Reference	Boolean functions
Green	B-C(Lt)/B-G (Rt)	$X'YZ$
Green	B-E (St)	$XYZ' + X'Y'Z$
Red	B-E (St)	$X + Y'Y'Z'$
Yellow	B-E (St)	$X'YZ$
Green	D-E (Lt)/D-A (Rt)	$XYZ$
Green	D-G (St)	$XYZ' + XY'Z$
Red	D-G (St)	$X' + XY'Z'$
Yellow	D-G (St)	$XYZ$
Green	F-G(Lt)/F-C (Rt)	$X'Y'Z'$
Green	F-A (St)	$X'Y'$
Red	F-A (St)	$X + X'YZ$
Yellow	F-A (St)	$X'YZ'$
Green	H-A (Lt)/H-E (Rt)	$XYZ'$
Green	H-C (St)	$XY'$
Red	H-C (St)	$X' + XYZ$
Yellow	H-C (St)	$XYZ'$
Green	Walk (N-S/S-N)	$X'YZ' + X'Y'Z$
Green	Walk (E-W/W-E)	$XYZ' + XY'Z$

Note. X', Y', and Z' denote complements of variables X, Y, and Z, respectively.

## II. CONCLUSIONS

i) The system will never fail as there is a separate 60 seconds delay which only depends on the change of state of the 3-bit binary counter. So even if the laser mechanism or the 8 seconds delay fails to operate, the 60 seconds delay will continue to operate and thus the closed loop system converts into an open loop system and reduces all chances of accidents.

ii) Here we only apply one special condition in the road. From head of a road there will be zebra crossing, then the laser mechanism and finally the vehicle stopping mark. The three should not collide with each other.

iii) The above condition can hold good at all times when we are implanting two traffic police at the junction of the roads. Also fencing at the side of the roads is necessary upto the laser mechanism.

## REFERENCES

[1] I.J. Nagrath, "Control Systems Engineering", New Age International.

[2] S. Hasan Saeed, "Control Systems", SK Kataria & Sons.  
 [3] Forrest M. Mims iii, "Timer, Op Amp & Optoelectronic Circuits & Projects", Master Publishing Inc.  
 [4] Anil K. Maini, "Digital Electronics: Principles, Devices and Applications", Wiley.  
 [5] Nair B. Somanathan, "Digital Electronics and Logic Design", PHI.  
 [6] Anand Kumar, "Fundamentals of Digital Circuits", PHI.

## AUTHORS

**First Author** – Reshmi Banerjee, M.Tech., Guru Nanak Institute of Technology, e-mail : banerjee.reshmi@gmail.com, Alternate e-mail : reshmi26@rediffmail.com, Contract No. 09830319497.

# Age-related macular degeneration: Prevalence and Risk factors in elderly population (aged >60 years) in Central India

Dr. RP Singare\* Deshmukh S, Ughade SN\*\*, Thakre SB\*\*

\* Mahatme Eye Hospital, Nagpur

\*\* Community Medicine Department, Government Medical College, Nagpur, MS, India

**Abstract-** Objectives: Age-related macular degeneration (AMD) is a leading cause of irreversible blindness in elderly population. The purpose of the present study was to estimate the prevalence and identify risk factors and covariates of AMD in a hospital population of Central India.

**Materials and methods:** This cross sectional study was carried out at tertiary eye institute at Nagpur, Central India. Study was conducted between October 2012 and September 2013. Institutional ethics clearance was sought. Newly registered patients of both the sex, with  $\geq 50$  years of age attending the study hospital were selected for detailed ophthalmic examinations and evaluation.

**Results:** Out of the (n= 4.638) study sample; 107 subjects were diagnosed with age related macular degeneration in some form (i.e. dry or wet), thereby yielding a crude prevalence rate of 2.31% (95% Confidence Interval 1.95% - 2.66%). Significant associations were found between AMD and Age >60 years (Odds ratio= 2.37, 95% CI 1.49-3.77, p=0.0001), Gender (OR= 1.49, 95% CI 1.03-2.18, p=0.0366), etc.

**Conclusion:** Majority of the risk factors belong to non-modifiable category hence little can be done but early detection of AMD is utmost important. Smoking, CVD, and prior cataract surgery have shown it significant role as a predictors of AMD.

**Index Terms-** Macular degeneration, blindness, elderly

## I. INTRODUCTION

In elderly population causes of irreversible blindness are cataract, glaucoma, metabolic diseases, etc. Some of the important morbid contributing to irreversible blindness is age-related macular degeneration (AMD). Available literature also reveals that 8.7% of all cases of blindness globally contributed by AMD. It is the primary cause of visual impairment in industrialized countries. [1,2] It has been estimated that eight million people will be affected with AMD worldwide by the year 2020; from that 10 to 20% will be late AMD responsible for approximately 90% of vision loss.[3] Although, there is considerable information on visual impairment in the Western world, to date there are only few studies on the prevalence and risk factors of AMD in Indian subcontinent.[4] It has therefore been included in the action plan of the World Health Organization, to address avoidable blindness in VISION 2020 program.[5]

Recent studies from India account the prevalence of AMD among 70 years and above as 2% and 3.7% which was comparable to Western countries.[4,6] Therefore, the investigation of risk factors of AMD is important in comprehending the disease and to suggest preventive measures that can retard or control AMD progression. Risk factors, such as hypertension, smoking, diabetes mellitus, cardiovascular disease, obesity, female sex and positive family history [6, 7, 8, 9, 10, 11] and their contributions to AMD had already been documented in literature in other settings and populations. The purpose of the present study was to estimate the prevalence and identify risk factors and covariates of AMD in a hospital population of Central India.

## II. MATERIALS AND METHOD

A present cross sectional study was carried out at tertiary health care centre at Nagpur, Central India. Study was conducted between October 2012 and September 2013 by consecutive sampling technique among  $\geq 50$  years of group of both sex. Institutional ethics clearance was sought before initiation of the study. Those study participants consented to participate,  $\geq 50$  years of age, and newly registered were included in the study. However, patients with follow up visit and any ocular surgery were excluded from the study.

Before screening and definitive examination, the study was explained in detail to all the participants. Verbal or written consent was obtained from all the participants. The study population included 5725 new patients visited the eye hospital, of whom 4,638 subjects (81.00%) participated in the study. Data pertaining to socio-demographic, personal medical history and lifestyle factors was collected by interview technique and documented in predesigned data collection tool. Self-reported hypertension or diabetes and its duration from diagnosis were recorded. Height and weight of all subjects were measured and documented to find out the body mass index (BMI). [12] Lifestyle factors like smoking and alcohol consumption were explored by means of interview and were categorised as never smokers and smokers. If duration of smoking less than one year were categorised as non-smokers. Cumulative smoking dose was determined by frequency of number of cigarettes/cigars per day. The pack year was calculated by multiplying the number of packs of cigarettes or cigars smoked per day by the number of year's person had smoked. Based on cigarettes pack year's smokers were categorised as light and heavy smokers.

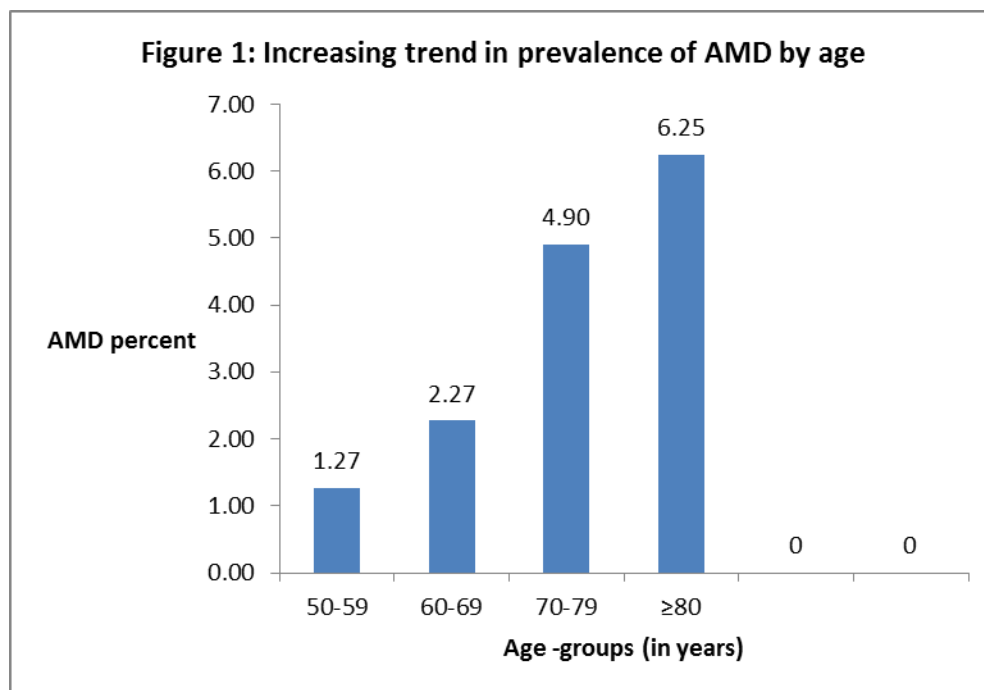
All the ophthalmic examination was performed by investigating ophthalmologists. The examination was conducted according to a standardized protocol that included visual acuity, autokeratometer refractometer (KR-8100; Topcon, Tokyo, Japan), computerized tonometer (CT-80; Topcon, Tokyo, Japan) and slit lamp biomicroscopy (SL-IE; Topcon, Tokyo, Japan) with 90 D and 78 D lens through a dilated pupil with tropicamide (0.8%) and phenylephrine (5%). For grading lens opacity, each eye was compared with the Lens Opacities Classification System (LOCS III) photographs.[13] A modified classification of diabetic retinopathy was used in our study.[14] Anterior segment was photographed with a camera (Nikon Corporation, Tokyo, Japan) mounted to slit lamp with a fundus camera (Kowa VX-10, Japan). Photographs were classified according to an international classification and grading system of age related macular degeneration. [15] The features were examined for hard and soft drusens, changes in the retinal pigment epithelium (RPE), geographic atrophy, choroidal neovascular membrane, and disciform scar. AMD was classified as late (neovascular or geographic atrophy) or early (soft drusen or retinal RPE abnormalities), they were combined for analysis in the present study. The cases of AMD, thus, detected were also confirmed by the principal ophthalmologist. When both the eyes of

participants had lesions of different severity, the grade assigned for the participant was that of the more severely involved eye.

Statistical analysis: The data were analysed using the Microsoft excel (version MS 2013) software packages. Descriptive statistics was used to determine mean, and percentages. Categorical data were analysed and the association of AMD with risk factors was assessed by bivariate analysis. Significance was derived by using Chi Square Test and Fisher's Exact Test. P value <0.05 was considered statistically significant. Strength of association was established by deriving Odd ratios (ORs) and 95% confidence interval (CI). Effect of each factors independently on dependent variable (AMD) were calculated using logistic regression with variance calculation.

### III. RESULTS

Out of the (n= 4.638) study sample; 107 subjects were diagnosed with age related macular degeneration in some form (i.e. dry or wet), thereby yielding a crude prevalence rate of 2.31% (95% Confidence Interval 1.95% - 2.66%). As the age of the subjects increased, the prevalence of AMD also increased (Figure 1), the prevalence being almost double in 70-79 years and triple in 80+ years as compared to 60-69 years subjects.



**Table 1 reveals that majority of the subjects were below 70 years of age, females, non-obese, non-smokers and non-alcoholic with high proportion reporting with hypertension (47.11%), some with cardio-vascular morbidity (6.22%)z and diabetes (9.84%) as well. Some (7.15%) had already undergone cataract surgery.**

**Table 1. Demographic and behavioral characteristics and morbidity profile of study subjects (N=6954)**

<b>Characteristics</b>	<b>Number</b>	<b>%</b>
<b>Age in years</b>		
50-59	1805	38.92
60-69	2154	46.44
70-79	551	11.88
≥80	128	2.76
<b>Gender</b>		
Male	2224	47.96
Female	2414	52.04
<b>Smoking status</b>		
Smokers	650	14.01
Non-smokers	3988	85.99
<b>Alcohol Consumption</b>		
Alcoholic	904	19.50
Non-alcoholic	3734	80.50
<b>Morbidity profile</b>		
<b>Hypertension</b>		
Present	2185	47.11
Absent	2453	52.89
<b>Diabetes</b>		
Present	288	6.22
Absent	4350	94.80
<b>CVD</b>		
Present	456	9.84
Absent	4182	90.16
<b>Obesity/Overweight</b>		
Obese	423	9.11
Non-obese	4215	90.89



<b>Cataract Surgery</b>		
Yes	332	7.15
No	4306	92.85

Table 2 presents the results of bivariate analyses done to examine association of AMD with some potential risk factors. Significant associations were found between AMD and Age >60 years (Odds ratio= 2.37, 95% CI 1.49-3.77, p=0.0001), Gender (OR= 1.49, 95% CI 1.03-2.18, p=0.0366), Smoking (OR= 2.17, 95% CI 1.37-3.43, p=0.0001), Alcohol (OR = 1.71, 95% CI 1.11- 2.63, p=0.0134), CVD (OR = 1.96, 95% CI 1.21- 3.06, p=0.0020), CVD (OR = 2.00, 95% CI 1.21- 3.31, p=0.0058) and Prior Cataract Surgery (OR = 4.95, 95% CI 3.16- 7.76, p=0.0001). However, some other factors like hypertension, diabetes, obesity and family history of AMD were not found to be significantly associated with AMD in our study population.

**Table 2. Potential risk factors of AMD identified in bivariate analyses**

Correlates	No	Subjects with AMD No. (%)	OR (95% CI)	P value
<b>Age in years</b>				
>60	2833	84 (2.97)	2.37 (1.49-3.77)	0.0001
≤60	1805	23 (1.27)		
<b>Gender</b>				
Female	2435	72 (2.97)	1.49 (1.03-2.18)	0.0366
Male	2203	44 (2.00)		
<b>Smoking status</b>				
Smokers	616	25 (4.06)	2.17 (1.37-3.43)	0.0001
Non-smokers	4022	77 (1.91)		
<b>Alcohol Consumption</b>				
Alcoholic	890	30 (3.37)	1.71 (1.11-2.63)	0.0134
Non-alcoholic	3748	75 (2.00)		
<b>Morbidity profile</b>				
<b>Hypertension</b>				
Present	2261	55 (2.43)	1.21 (0.82-1.79)	0.3398
Absent	2377	48 (2.02)		
<b>Diabetes</b>				
Present	242	2 (0.83)	0.27 (0.07-1.09)	0.0497
Absent	4396	132 (3.00)		
<b>CVD</b>				
Present	430	19 (4.42)	2.00 (1.21-3.31)	0.0058
Absent	4208	95 (2.27)		
<b>Obesity/Overweight</b>				
Obese	579	12 (2.07)	0.93 (0.51-1.72)	0.8242
Non-obese	4059	90 (2.22)		
<b>Prior Cataract Surgery</b>				
Yes	346	28 (8.01)	4.95 (3.16-7.76)	0.0001
No	4292	75 (1.75)		
<b>Family history of AMD</b>				
Present	11	1 (9.09)	4.24 (0.54-33.31)	0.1366



Absent	4627	107 (2.31)		
--------	------	------------	--	--

Adjusted estimates of odds ratio from Multiple logistic regression analysis (Table 3) revealed that four factors together contributed significantly in causation of AMD namely Prior Cataract Surgery (AOR = 7.98, 95% CI 5.31- 12.25, p=0.0001), Age (AOR = 4.09, 95% CI 2.52- 6.48, p=0.0001), CVD (OR =

2.55, 95% CI 1.44- 3.79, p=0.001), and Smoking (OR= 2.51, 95% CI 1.39-3.67, p=0.0001). However, alcohol consumption which was found to have a significant association with AMD in bivariate analysis failed to retain the same in presence of other factors (in multivariate analysis).

**Table 3: Multiple logistic regression analysis for assessment of association between potential risk factors and AMD**

Risk Factors	Adjusted Odds Ratio (AOR)	95% CI	P value
Age	4.09	2.52-6.48	0.0001
Smoking	2.51	1.39-3.67	0.0001
Alcohol consumption	1.73	1.03-2.38	0.1498
CVD	2.55	1.44-3.79	0.001
Prior cataract surgery	7.98	5.31-12.25	0.0001

#### IV. DISCUSSION

In this study overall estimated prevalence of AMD was 2.31%. Since, the study sample was consecutively selected from tertiary care attendees at the time of their first registration at hospital; it represents the prevalence rate of AMD of those registered. Although the registration and screening were done at different times the data should be considered as point prevalence. Our estimate of AMD (2.31%) from the hospital was similar to that reported in another India study [16] However; other Indian population as 1.82% in the Andhra Pradesh Eye Disease Study[6] and Western population as 1.51% in the Beaver Dam Eye Study [17] and 1.81% in the Blue Mountain Eye Study.[18] These slight differences in the prevalence of AMD among the studies could be due to the differences in environmental exposure among the population, genetic factors or perhaps to the difference in the methodology adopted.

The prevalence of AMD among >70 years found in this study was 11.15%. However; in earlier studies proportion MESA whites (13.3%), but was much lower than in the Beavers Dam whites (36.8%).[19] Results of the earlier study clearly demonstrated that prevalence of AMD in 70 + years is higher than that of less than 70 years. In the present study increasing age is associated with AMD. This finding is consistent with the other studies. Therefore, increasing age is strongly associated with AMD.[4,6,17,18, 19, 20,21] Data from this hospital based study demonstrated an association between age and AMD. Cigarette smoking, alcohol consumption and diabetes were also significantly associated with AMD.

The present study, no significant (OR 1.14; P=0.447) differences was observed in both the genders. However, previous studies, found that the prevalence AMD significantly increased in women as compared to men.[ 16, 19,20] Western white population, have shown a higher prevalence of AMD in women.[3,5,7] Present study also showed a strong association between heavy smoking (OR 2.26; P=0.0001) and AMD. Cigarette smoking was constantly been identified as a risk factor for AMD.[6,7,8,9,10,16] Alcohol consumption (OR 1.86) and

risk of AMD showed a strong alliance, which was similar to Bhatiwada study [16] and Los Angles Latino Eye Study.[26] We did not find hypertension and diabetes to be associated with AMD in the sample population. Similar findings reported by Bhatiwada et al. [16] There are conflicting reports relates to association of hypertension and AMD. [3] However; evidenced higher odds (1.22) in the hypertensive group and diabetes (OR 3.97) showed strong association with AMD, which was in line with European Eye Study.[22]

The current study showed no significant association between BMI and AMD, which is consistent with a number of other studies have recorded no relationship between BMI and AMD.[6, 23]

Presence of history of cataract surgery significantly (OR 4.97; 0.0001) associated with an increased risk of AMD.[24] Previous studies in which a higher prevalence of AMD was reported in the presence of cortical cataract or cataract surgery.[6,9,10]

Apart from dietary and lifestyle risk factors associated with AMD [16]; a series of special conditions imposed upon photoreceptors puts them in high risk pro-oxidant environment. Oxidative damage in the retina has been hypothesized as a key process involved in the development of early age related macular degeneration [25]. In another study it has highlighted the role of oxidative stress in the pathogenesis of AMD.[26]

#### REFERENCES

- [1] World Health Organization. Age Related Macular Degeneration: Priority eye diseases. [Last accessed on 2014 December 6]. Available from: <http://www.who.int/blindness/causes/priority/en/index8.html> .
- [2] Bialek-Szymańska A, Misiuk-Hojło M, Witkowska K. Risk factors evaluation in age-related macular degeneration. *Klin Oczna* 2007;109:127–30.
- [3] Bressler NM. Early detection and treatment of neovascular age related macular degeneration. *J Am Board Fam Pract* 2002;15:142–52.
- [4] Nirmalan PK, Katz J, Robin AL, Tielsch JM, Namperumalsamy P, Kim R, et al. Prevalence of vitreoretinal disorders in a rural population of Southern India: The Aravind Comprehensive Eye Study. *Arch Ophthalmol* 2004;122:581–6.
- [5] World Health Organization. Age Related Macular Degeneration: Disease control and prevention of visual impairment in global initiative for the

- elimination of Avoidable Blindness Action Plan 2006–2011. Printed in France. 2007. [Last accessed on 2010 Nov 26]. pp. 32–3. Accessed from: [http://www.who.int/blindness/Vision2020\\_report.pdf](http://www.who.int/blindness/Vision2020_report.pdf)
- [6] Krishnaiah S, Das T, Nirmalan PK, Nutheti R, Shamanna BR, Rao GN, et al. Prevalence of vitreoretinal disorders in a rural population of southern India: The Aravind Comprehensive Eye Study. *Invest Ophthalmol Vis Sci.* 2005;46:4442–9.
- [7] Age-Related Eye Disease Study Research Group. Risk factors associated with age-related macular degeneration-A case-control study in the age-related eye disease study: Age-Related Eye Disease Study report number 3. *Ophthalmology.* 2000;107:2224–32.
- [8] Cackett P, Wong TY, Aung T, Saw SM, Tay WT, Rochtchina E, et al. Smoking, cardiovascular risk factors and age-related macular degeneration in Asians: The Singapore Malay Eye Study. *Am J Ophthalmol* 2008;146:960–7.
- [9] Klein R, Klein BE, Wong TY, Tomany SC, Cruickshanks KJ. Association of cataract and cataract surgery with the long-term incidence of age-related maculopathy: The Beaver Dam Eye Study. *Arch Ophthalmol* 2002;120:1551–8.
- [10] Wang JJ, Klein R, Smith W, Klein BE, Tomany S, Mitchell P. Cataract surgery and the 5-year incidence of late stage age-related maculopathy: Pooled finding from the Beaver Dam and Blue Mountains eye studies. *Ophthalmology.* 2003;110:1960–7.
- [11] Klein R, Peto T, Bird A, Vannewkirk MR. The epidemiology of age-related macular degeneration. *Am J Ophthalmol.* 2004;137:486–95.
- [12] WHO growth standards 2014. Available on [http://www.cdc.gov/healthyweight/assessing/bmi/adult\\_bmi/](http://www.cdc.gov/healthyweight/assessing/bmi/adult_bmi/). Last access on: 10th Dec 2014.
- [13] Chylack LT, Jr, Wolfe JK, Singer DM, Leske MC, Bullimore MA, Bailey IL, et al. The Lens Opacities Classification System III. The longitudinal study of cataract study group. *Arch Ophthalmol.* 1993;111:831–6.
- [14] Klein R, Klein BE, Magli YL, Brothers RJ, Meuer SM, Moss SE, et al. An alternative method of grading diabetic retinopathy. *Ophthalmology.* 1986;3:1183–7.
- [15] Bird AC, Bressler NM, Bressler SB, Chisholm IH, Coscas G, Davis MD, et al. An international classification and grading system for age-related maculopathy and age-related macular degeneration. The International ARM Epidemiological Study Group. *Surv Ophthalmol.* 1995;39:367–74.
- [16] Bhatiwada N, Mamata SB, Padmaprabhu CA, Pallavi P, Wallikannan B. Dietary and Lifestyle risk factors associated with age related macular degeneration: A hospital based study. *Indian J Ophthalmology* 2013;62(12):722-27.
- [17] Klein R, Klein BE, Linton KL. Prevalence of age-related maculopathy: The Beaver Dam Eye Study. *Ophthalmology.* 1992;99:933–43.
- [18] Mitchell P, Smith W, Attebo K, Wang JJ. Prevalence of age-related maculopathy in Australia: The Blue Mountains Eye Study. *Ophthalmology.* 1995;102:1450–60.
- [19] Klein R, Klein BE, Knudtson MD, Wong TY, Cotch MF, Liu K, et al. Prevalence of age-related macular degeneration in 4 racial/ethnic groups in the multi-ethnic study of atherosclerosis. *Ophthalmology* 2006;113:373–80.
- [20] Xu L, Li Y, Zheng Y, Jonas JB. Associated factors for age related maculopathy in the adult population in China: The Beijing Eye Study. *Br J Ophthalmol* 2006;90:1087–90.
- [21] Kawasaki R, Wang JJ, Aung T, Tan DT, Mitchell P, Sandar M, et al. Prevalence of age-related macular degeneration in a Malay population: The Singapore Malay Eye Study. *Ophthalmology* 2008;115:1735–41.
- [22] Topouzis F, Anastasopoulos E, Augood C, Bentham GC, Chakravarthy U, de Jong PT, et al. Association of diabetes with age-related macular degeneration in the EUREYE study. *Br J Ophthalmol* 2009;93:1037–41.
- [23] Klein R, Klein BE, Jensen SC, Mares-Perlman JA, Cruickshanks KJ, Palta M. Age-related maculopathy in a multiracial United States population. The National Health and Nutrition Examination Survey III. *Ophthalmology* 1999;106:1056–65.
- [24] Xu L, Li Y, Zheng Y, Jonas JB. Associated factors for age related maculopathy in the adult population in China: The Beijing Eye Study. *Br J Ophthalmol* 2006;90:1087–90.
- [25] Elaine WC, Tien W, Andreas JK, Julie AS, Robyn HG. Dietary antioxidants and Primary prevention of age related macular degeneration: Systematic review and meta analysis. *BMJ* 2007;335(7623)755.
- [26] Singh SB, Singh B. Plasma malondialdehyde level in age related macular degeneration. *J ournal of Clinical Diag Res* 2018;4(4):2768-69.

#### AUTHORS

**First author:** Dr. RP Singare, Consultant Ophthalmologist, Mahatme Eye Hospital, Nagpur

**Second Author:** Dr S Deshmukh, Consultant Ophthalmologist, Mahatme Eye Hospital, Nagpur

**Third Author:** Dr. S Ughade, Assistant Professor, Department of Community Medicine, Government Medical College, Nagpur.

**Fourth Author:** Dr S Thakre, Deputy Superintendent, Government Medical College and hospital, Nagpur.

**Correspondence Author –** Dr. RP Singare, Consultant Ophthalmologist, Mahatme Eye Hospital, Nagpur  
[drsubhasht@rediffmail.com](mailto:drsubhasht@rediffmail.com)

# Integrating Risk Reduction Strategies for a Sustainable Disaster Management in Nigeria

Arc. Abubakar Sarkile Kawuwa\*, Sani Jauro Adamu\*\*, Abdullahi Taofik Umar\*\*\*

\* B.sc, M.sc Arch. (ABU) mnia, Department Of Architecture, Abubakar Tafawa Balewa University, Bauchi, Nigeria.

\*\* B.Tech. Env. Mgt., (ATBU), Department Of Geography, Gombe State University, Gombe, Nigeria

\*\*\* B.sc BIO. Sci. (UNIBUJA), Department Of Biological Sciences, Gombe State University, Gombe, Nigeria

**Abstract-** Disasters, both natural and man-made, are important factors that not only bring about widespread damages and socio-economic losses, but seriously retard human progress. At the same time, human societies, now more than ever before, are faced with delicate issues of achieving development and ensuring that development processes are sustained. Since the end of the last century, the issue of sustainability of developmental processes had become an issue of much dialogue and academic discourse, which has substantially dominated multilateral and international relations. This paper examines how disaster management strategies can be integrated with those of sustainable development. The paper discusses the disaster management cycle and shows how development considerations contribute to all its aspects. It concluded that for sustainable disaster management to be achieved and risk to disaster reduced, environmental considerations must be a central part of government and industry decision-making process.

**Index Terms-** Development, Disaster, Management, Risk, Strategies, Sustainability

## I. INTRODUCTION

**D**isaster is a sudden event such as flood, storm or accident which causes great damage or suffering. A disaster describes a situation where the occurrence of abnormal infrequent events that has impact on vulnerable communities, causing substantial damage, disruption and possible casualties and leaving the affected communities unable to function normally without external assistance.

Otero and Marti (1995) define disaster again, as emergency caused by natural hazards or human-induced actions and resulting in a significant change in circumstances over relatively short period of time. Typical examples are death, displacement, diseases, loss of crops, damage to physical and service infrastructure, depletion of natural and social capitals etc. A broad definition of disasters includes the fact that they are dramatic, sudden, unscheduled events that are often accompanied by large losses of human lives, suffering and affliction to a society or significant part of it and a temporary breakdown of prevailing lifelines and systems. Such events cause considerable material damages and interrupt normal functioning of an economy and of society in general.

Disasters and emergencies have turned back the hands of development clock by destroying years of efforts and labour and by so doing perpetuating poverty and underdevelopment through

the destruction of infrastructure and other socio-economic investments. It consequently drains both national and international development funds through rehabilitation and reconstruction efforts of both local and international monetary funds (Moreno, 2001, UNCHS).

During the past four decades, disasters have caused major losses of human life and livelihoods; destruction of economic and social infrastructure and significant environmental damage. Moves towards sustainable development and poverty reduction initiatives are threatened by disasters triggered by hazards of hydro-metrological, geological and environmental origin often amplified by human activities or technology. Natural disasters such as hurricanes wipe out years of urban development by destroying infrastructure, housing and injuring or killing thousands of people.

Developing nations in particular, experience pervasive risks of devastation, human and property loss resulting from natural disasters. According to Henderson (2004), this level of risk is attributable to socio-economic stress, aging and inadequate physical infrastructure, weak education, preparedness for disaster, insufficient fiscal and economic resources to carefully implement the preparedness, response, mitigation and recovery components of integrated emergency management.

In spite of high vulnerabilities of African countries to environmental and technological disasters, poverty and diseases, disaster is hardly regarded to be an integral part of the urban-national development strategies. Disaster management is seen merely as an emergency relief doling exercise and not as an integral part of national development (Ojo, 2005).

A report "Before Disaster Strikes" by Tearfund (2005) an NGO based in the United Kingdom asserts that 98 per cent of people killed by natural disasters now come from developing countries and that by 2015 half of the people living in the developing world will be highly vulnerable to floods and storms. Based on the environmental conditions and socio-economic development paradigm in Nigeria, it is assumed that we are included (Olokesusi, 2005).

The occurrence of disaster offers a good opportunity to formulate forward-looking policy concepts pertaining to social development and equity, economic growth, environmental quality, and sustainability. However, to be successful, the integration of holistic disaster reduction strategies into development policies is imperative and necessary to solve a broad range of social, economic, and environmental problems. The integration will require the participation of sectors of the economy such as environment, finance, industry, transport, construction, education and health. it would of course involve

different forms of management than in the case of emergency or disaster management.

The objective of this paper is to integrate the risk reduction strategies with that of sustainable development and encourage disaster management cycle along sustainable ways.

## II. SUSTAINABLE DEVELOPMENT (AN OVERVIEW)

It is undisputable that natural resources provide the major attractions for foreign earnings and must therefore be exploited, But the economy serves as the major stressor of the environment unless if a balance is maintained between use and conservation of environmental resources. (Bakkes and Van Woerden, 1997). A strong national economy should, therefore, not only be capable of addressing the developmental needs of the people but should be a key factor in protecting the environment. This is to say the development should go beyond economic growth (Daly, 1996). The focus of development economics therefore should be on sustainability development processes not merely on economic development. It is on this basis that nations of the world now vigorously pursue what is universally called sustainable development (Mashi, 2005).

In consequence of this, there has been growing change in the way environmental and developmental policies, programs, and projects are now formulated and implemented in many countries of the world (Colby, 1995; Serageldin, 1995). There is now a sort of new developmental environmentalism, characterized by greater precision in factoring environmental costs and benefits in policy making. It puts local people in the centre of environmental strategies, diagnoses and addresses behavioural causes of environmental damage, and recognizes the political dimensions of environmental reform (Christiansen, 1991).

An important recommendation of the United Nations Conference on Environment and Development (The Earth Summit) held in Rio de Janeiro, in 1992, was that individual countries should prepare strategies and plans that contain real commitments and targets, and sustainable measures in order to make progress on the problems affecting global environment (Mashi, 2005). Agenda 21 (1992) one of the summit's major output calls for a comprehensive program of action needed throughout the world to achieve a more sustainable pattern of development for the next century. Agenda 21 placed great emphasis on the need for all sectors of society to participate in the formation of effective national development strategies for sustainable development (Mashi, 2005). Since the summit, many countries are trying to relate sustainable development to their national policy-makers. Sustainable development is viewed as vital necessity to reconcile the two basic aspirations of a society, namely economic development and job creation, and environmental protection of limited natural resources (Hatcher, 1995).

At the end of last millennium, the term 'sustainability' became an overall guiding principle for human development, Its success stems from the underlying reflections of existential problems of mankind perceived at that time: increasing concern over exploitation of natural resources and economic development at the expense of environmental quality (Mashi, 2005).

The word 'sustainability' means different things to different people, to some it means integration of the social, economic, and

environmental domains while to some, the continuity of the currently preferred quality of life (Gbadegesin and Emuh, 2005). To some it is a development which "meets the needs of the present without compromising the ability of the future to meet their own needs". Since it is generally recognize that the world's present development path is not sustainable, in spite of the substantial efforts to achieve this goal in the last decade, the world community is now focusing attention on what is need to be done in its quest to achieve sustainable development. The challenge for us as a society is to agree on practical definition of sustainability and then develop a road map to achieve it. The road map should include policies, incentives, and research and development agendas.

The emerging public philosophy of sustainability is a call to ethical responsibility. It focuses directly on the values that are precondition to a just sustainable world. In seeking a public philosophy of sustainability, we clearly affirm sustainability itself as a moral value. We interpret sustainability broadly to mean a condition in which natural systems and social survives and thrive together indefinitely. Today it becomes a basic human responsibility to ensure that both natural and human systems are sustained in a condition of health – for the sake of earth (Gbadegesin and Emuh, 2005).

The term 'Sustainable Development' was brought into common use by the World Commission on Environment and Development. It's much quoted but vague definition refers to development which "seeks to meet the needs and aspirations of the present without compromising the ability to meet those needs of the future", (Brundtland, 1987). A less imprecise definition by Brundtland (1991) is "a process in which the exploitation of resources, the direction of investments, the orientation of technical departments and institutional change are all in harmony, and enhance both current and future potentials to meet human needs and aspirations."

As stated in UK Sustainable Development Strategies (1994), most societies aspire to achieve economic development to secure rising standards of living, both for themselves and for future generations. They also seek to protect and enhance their environment, now and for future. Reconciling these two aspirations of society is at the heart of sustainable development. Sustainable development, which includes community development, environmental protection, natural resources conservation, and local economic development, is becoming more widely practised all over the world. Since sustainable development planning requires civic planners and private developers to understand a number of new disciplines and to address their interconnections, it has been difficult for working professionals to gain an overview and access to specific implementation strategies.

Although there is growing consensus about the magnitude and nature of problems, there is still intense debate about the priorities among the issues. Moreover, since the released of the 1987 UN Brundtland Report (Our Common Future) and subsequent introduction of the term "sustainable development" into everyday language, there has been extensive dialogue about the type of policy instruments to employ the relative degree of government intervention required. While discussions are useful about the effectiveness of regulatory regimes versus market mechanisms, or some combination of these, our land, air and



water continue to become increasingly degraded. If one accepts the immediacy and urgency of acting now, and the necessity for institutional restructuring, fundamental change in the way we make decisions and the way we do business, many different kinds of policy levers will be required to achieve the necessary scale of change in this decade, especially as it affects risk reduction and disaster management.

## **2.1 DISASTER MANAGEMENT CYCLE AND SUSTAINABLE DEVELOPMENT**

Disaster management aims to reduce, or, avoid the potential losses from hazards, assure prompt and appropriate assistance to victims of disaster, and achieve rapid and effective recovery. The Disaster management cycle illustrates the on-going process by which governments, businesses, and civil society plan for and reduce the impact of disasters, react during and immediately following a disaster, and take steps to recover after a disaster has occurred. Appropriate actions at all points in the cycle lead to greater preparedness, better warnings, reduced vulnerability or the prevention of disasters during the next iteration of the cycle. The complete disaster management cycle includes the shaping of public policies and plans that either modify the causes of disasters or mitigate their effects on people, property, and infrastructure.

The mitigation and preparedness phases occur as disaster management improvements are made in anticipation of a disaster event. Developmental considerations play a key role in contributing to the mitigation and preparation of a community to effectively confront a disaster. As a disaster occurs, disaster management actors, in particular humanitarian, organizations become involved in the immediate response and long-term recovery phases. The four disaster management phases illustrated here do not always, or even generally, occur in isolation or in this precise order. Often phases of the cycle overlap and the length of each phase greatly depends on the severity of the disaster.

Developmental considerations contribute to all aspects of the disaster management cycle. One of the main goals of disaster management, and one of its strongest links with development, is the promotion of sustainable livelihoods and their protection and recovery during disasters and emergencies. Where this goal is achieved, people have a greater capacity to deal with disasters and their recovery is more rapid and long lasting. In a development oriented disaster management approach, the objectives are to reduce hazards, prevent disasters, and prepare for emergencies. Therefore, developmental considerations are strongly represented in the mitigation and preparedness phases of the disaster management cycle. Inappropriate development processes can lead to increased vulnerability to disasters and loss of preparedness for emergency situations.

### **2.1.1 MITIGATION**

Mitigation activities actually eliminate or reduce the probability of disaster occurrence, or reduce the effects of unavoidable disasters. Mitigation measures include building codes; vulnerability analyses updates; zoning and land use management; building regulations and safety codes; preventive health care; and public education.

Mitigation will depend on the incorporation of appropriate measures in national and regional development planning. Its

effectiveness will also depend on the availability of information on hazards, emergency risks, and the countermeasures to be taken. The mitigation phase, and indeed the whole disaster management cycle, includes the shaping of public policies and plans that either modify the causes of disasters or mitigate their effects on people, property, and infrastructure.

### **2.1.2 PREPAREDNESS**

The goal of emergency preparedness programs is to achieve a satisfactory level of readiness to respond to any emergency situation through programs that strengthen the technical and managerial capacity of governments, organizations, and communities. These measures can be described as logistical readiness to deal with disasters and can be enhanced by having response mechanisms and procedures, rehearsals, developing long-term and short-term strategies, public education and building early warning systems. Preparedness can also take the form of ensuring that strategic reserves of food, equipment, water, medicines and other essentials are maintained in cases of national or local catastrophes.

During the preparedness phase, governments, organizations, and individuals develop plans to save lives, minimize disaster damage, and enhance disaster response operations. Preparedness measures include preparedness plans; emergency exercises/training; warning systems; emergency communications systems; evacuations plans and training; resource inventories; emergency personnel/contact lists; mutual aid agreements; and public information/education. As with mitigations efforts, preparedness actions depend on the incorporation of appropriate measures in national and regional development plans. In addition, their effectiveness depends on the availability of information on hazards, emergency risks and the countermeasures to be taken, and on the degree to which government agencies, non-governmental organizations and the general public are able to make use of this information.

### **2.1.3 RESPONSE**

The aim of emergency response is to provide immediate assistance to maintain life, improve health and support the morale of the affected population. Such assistance may range from providing specific but limited aid, such as assisting refugees with transport, temporary shelter, and food, to establishing semi-permanent settlement in camps and other locations. It also may involve initial repairs to damaged infrastructure. The focus in the response phase is on meeting the basic needs of the people until more permanent and sustainable solutions can be found. Humanitarian organizations are often strongly present in this phase of the disaster management cycle.

### **2.1.4 RECOVERY**

As the emergency is brought under control, the affected population is capable of undertaking a growing number of activities aimed at restoring their lives and the infrastructure that supports them. There is no distinct point at which immediate relief changes into recovery and then into long-term sustainable development. There will be many opportunities during the recovery period to enhance prevention and increase preparedness, thus reducing vulnerability. Ideally, there should be a smooth transition from recovery to on-going development.



Recovery activities continue until all systems return to normal or better. Recovery measures, both short and long term, include returning vital life-support systems to minimum operating standards; temporary housing; public information; health and safety education; reconstruction; counselling programs; and economic impact studies. Information resources and services include data collection related to rebuilding, and documentation of lessons learned.

## 2.2 DISASTER RISK REDUCTION AND STRATEGIES

The ISDR (2000) defines disaster risk reduction as the “systematic development and application of policies, strategies and practices to minimize vulnerabilities and disaster risk in throughout a society, to avoid or limit adverse impacts of hazards, within a broader context to sustainable development”. The World Conference on Natural Disaster Reduction held in the city of Yokohama, Japan in 1994 (UN/ISDR, 2004) adopted the following principles, strategies and plan for actions for a safer world:

- Risk assessment is a required step for the adoption of adequate and successful disaster reduction policies and measures.
- Disaster prevention and preparedness are of primary importance in reducing the need for disaster relief.
- Disaster prevention and preparedness should be considered integral aspects of development policy and planning at national, regional, multilateral and international levels.
- The development and strengthening of capacities to prevent, reduce and mitigate disasters is a top priority area to be addressed so as to provide a strong basis for follow-up activities to the International Decade for Natural Disaster Reduction (IDNDR).
- Early warnings of impending disasters and their effective dissemination are key factors to successful disaster prevention and preparedness.
- Prevention measures are more effective when they involve participation at all levels from the local community through the national government to the regional and international level.
- Vulnerability can be reduced by the application of proper designs and patterns of development focused on target groups by appropriate education and training of the whole community.
- The international community accepts the need to share the necessary technology to prevent, reduce and mitigate disasters.
- Environmental protection as a component of sustainable development consistent with poverty alleviation is imperative in the prevention and mitigation of natural disasters.
- Each country bears the primary responsibility for protecting its people, infrastructure and other national assets from impact of natural disasters.

What the IDNDR and the Yokohama Plan of Action put in motion is an irreversible and beneficial, political and social process. This is what International Strategy For Disaster Risk

Reduction, launched by the General Assembly of the UN as a successor of International Decade For Natural Disaster Reduction (IDNDR) in 2000 to provide a global framework for action, is building upon: fostering more awareness, more public commitment, more knowledge and partnerships to implement risk reduction measures of all kinds at all levels (Ote, 2005).

Health and environmental scientists, professional risk managers and the general public strongly disagree about the seriousness of many risks. Most members of the public are concerned about long-term effects of risks, equity and fairness issues, lack of personal control, and pace of technological diffusion into their cultural environment, whereas professional risk managers focus on the task to minimize the probability of adverse effects caused by potentially hazardous agent or activity (Gbadegesin and Emuh, 2005).

The ISDR has the objective of reducing human, social, economic and environmental losses due to natural hazards and related technological and environmental phenomena. The ISDR aims at building disaster resilient communities by promoting increase awareness of the importance of disaster reduction as an integral component of sustainable development.

In Africa, the African Regional Strategy for Disaster Reduction with a common goal towards a disaster reduction that underpins the aim of New Partnership for Africa’s Development (NEPAD) has been developed (Nierkerk, 2004). According to Ote (2005) the strategy clearly stipulates the importance of a clear development focus towards solving disaster risk related issues in Africa. The objectives of the strategies are to:

- Increase political commitment to disaster.
- Improve identification and assessment of disaster risks.
- Enhance knowledge management for disaster risk reduction.
- Increase public awareness of disaster risk reduction.
- Improve governance of disaster risk reduction institutions.
- Integrate disaster risk reduction into emergency response management.

These objectives are in tandem with the aims of ISDR. The African Union (AU) strategy provides strategic direction towards the achievement of the above stated objectives. However, their attainment by African countries will demand a development shift in focus. It will entail a paradigm shift from an undue emphasis on disaster response to disaster risk management through the factoring of prevention and disaster reduction into sustainable development.

## 2.3 DISASTER RISK REDUCTION IN NIGERIA

Disaster risk reduction strategies, plans, policies and legislation exists in varied degrees in Nigeria, What has been lacking however, is common goal towards management of disaster that entails effective performance of six inter-related groups of activities namely: development planning, disaster prevention, mitigation, preparedness, response and recovery (Ologe, 2004). National Emergency Management Agency (NEMA) was established to coordinate and facilitate disaster management efforts nationwide. The same instrument that created NEMA stipulates that each State of the Federation should established State Emergency Management Committee (SEMC) to comprise the Governor as the chairman and other related

Departments of the Government to manage disasters in their domains. The Local Government authorities are also to set up the Local Government Emergency Management Committees to address emerging disasters in their respective domains (Ote, 2005).

Unfortunately, twelve years after the establishment of NEMA, many states in Nigeria are yet to establish their disaster management institutions to address the various cases of disaster events occurring in their own domains. In the states where this structure exists, a culture of reaction, which is disaster response with relief materials, is gradually developing with its negative effect of creating a sense of dependency by victims of disasters on external assistance. It has been observed that most of the disasters and emergencies in the communities such as floods, destructive storms, oil spills, wildfires, crop pests, ethno-religious conflicts, etc., being seasonal, are repetitive and cannot be effectively addressed by a reactionary and relief-driven paradigm. The multiplicities of these emergencies across the country with their budgetary implications for interventions could be burdensome and a big drain on national development (Ojo, 2004).

#### **2.4 DISASTER RESISTANT PLANNING AS AN APPROACH TO RISK REDUCTION**

As Architects, professionals in construction industry, and stakeholders in the sustenance of the environment, disaster resistant planning could be understood as a disaster risk reduction approach. The approach is used for minimizing the damage and disruption from disaster. It embraces a clear understanding of the relationships of how we manage growth and how we plan and developed our communities (neighbourhoods, buildings, infrastructure and other systems and components). Disaster resistant planning also accommodates how we relate development with the natural environment and the capacity of the environment to resist and to minimize disaster. A disaster resistant community is obtained when the goals of disaster resistant planning are achieved. Disaster resistant communities are sustainable communities in the local context. A sustainable community is defined as the one that uses its resources to meet the current needs while ensuring that adequate resources are available for future generations (UNEP, 1987).

Cities and towns like any human settlements are subject to various types of forces-physical, economic, social and administrative which influences their forms and structures. For instance, disaster of any nature whether natural or man-induced could exact so much force as to disrupt the socio-economic and political balance of the settlements, cause property damage and loss of human lives. The application of town planning tools such as contained in the building regulations and sub-division by-laws of the local government could help to coordinate the various forces and consequently ensures a disaster free environment.

Therefore, the application of town planning principles and indeed town planning tools (Development Plan and Development Control Mechanisms) in pre-event planning could be seen as a future oriented problem solving strategy which recognizes the relationship between planning, preparedness, response and recovery.

In summary, the relevance of town planning in disaster risk reduction is that it allows for a futuristic projection of potential

disaster and then allows us to formulate how we can mitigate it before it occurs.

### **III. INTEGRATING RISK REDUCTION STRATEGIES WITH SUSTAINABLE DEVELOPMENT**

There is now an international acknowledgement that efforts to reduce disaster risk must be systematically integrated into policies, plans and programmes for sustainable development and poverty reduction, and supported through bilateral, regional and international cooperation, including partnerships.

Sustainable development, poverty reduction, good governance and disaster risk reduction are mutually supportive objectives, and in order to meet the challenges ahead, accelerated efforts must be made to build necessary capacities at the community and national levels to manage and reduce risk. Such an approach is to be recognized as an important element for the achieving internationally agreed development goals, including those contained in the Millennium Declaration (Mashi, 2005).

Since sustainable development is about the environment, risk reduction strategies must be synergized with sustainable development strategies (UNDP, 1997).

Furthermore, because disaster represent a development challenge, the UN General Assembly passed a resolution 58/214 of 23 December, 2003 for the purpose of convening the World Conference on Disaster Reduction which was held on 18-22 January, 2005 in Kobe, Hyogo, Japan. The major outcomes of this conference are:

- Ensure that disaster risk reduction is a national and local priority with strong institutional basis for implementation.
- Identify, assess and monitor disaster risks and enhance early warning.
- Use knowledge, innovation and education to build a culture of safety and resilience at all levels.
- Reducing the underlying risk factors.
- Strengthened disaster preparedness for collective response at all levels.
- Encouraging governments to address problems created by mega cities, the location of settlements in high-risk areas and other man-made determinants of disaster.
- Encouraging governments to incorporate disaster risk reduction into national planning processes, including building codes.

The Millennium Development Goals have recently become a blueprint and roadmap for development after its endorsement by 189 world leaders in September 2000. It provides a yardstick for measuring the development progress of any nation. All of these targets touch upon areas which are closely linked to vulnerability to natural hazards, such as eradicating extreme poverty and hunger, achieving universal primary education, promoting gender equality, ensuring environmental stability and partnerships for development. For example, the goal of improving the lives of thousands of slum dwellers around the world living in high-risk areas by 2020; involves poverty reduction, proper land use planning and the improved understanding of vulnerability to disasters in densely populated areas.

According to Mashi (2005), Olaleye (2005), and Soyinka-Onilaja (2005), the provision of six among such goals which are directly relevant to the objective of linking risk reduction strategies to those of sustainable development are briefly examined below.

#### **Goal 1: Eradicating extreme poverty and hunger**

Extreme poverty and hunger has many consequences in relation to disaster risk reduction and the human condition in general. Extreme poverty lowers one's coping mechanism during and after the disaster and increases one's vulnerability to the debilitating impact of the disaster. The poorer you are, the more likely it is that you will live in a disaster prone area. As a nation, we have the political will to initiate and implement reforms that will bring about meaningful progress. Such include:

- Strengthening and diversifying livelihoods
- Encouraging responsible foreign investment
- A flexible and participatory approach to urban planning
- Building social security, including access to health education
- The provision of risk/loss spreading mechanisms for those excluded from insurance cover

#### **Goal 2: Promoting gender equality and empowerment of women**

Gender influences the type of hazard which an individual is exposed and an individual's access to recourses with which to build resilience to hazard and to recover from disaster. When structural constraints in society result in the exclusion of women from decision making or economic, risk will be unevenly spread. A look at the lives of female refugees and internally displaced persons will reveal how difficult it is for them to care for their families, especially the female headed households. We need more women in legislative positions to push for laws that will promote land reforms, ownership of dwellings, inheritance and employment rights, equal access to health, education, an justice.

#### **Goal 4: Reducing child mortality**

Children are at greater risk of being affected, injured or killed by disaster impact than adults. It is perhaps the indirect impact of disasters that have the greatest toll on children and interact with national mortality levels. Most important here is the loss livelihoods that can lead to extreme poverty and homelessness for children left behind.

Appropriate safety nets, such as help for extended families with the capacity to absorb orphans or well-run orphanages, can support many children. But for those children born into families whose livelihoods and homes have been taken away by disaster impact, the chances of survival in the first years of life will be reduced.

#### **Goal 6: Combating HIV/AIDS, malaria and other diseases**

For many people, natural hazard and shock is felt in many pressures. HIV/AIDS and other diseases can undermine individual and collective coping capacity, just as disaster impact can take away development gains and livelihoods, making people more vulnerable to illness.

Interventions to strengthen basic health care provision, family health care and preventative health planning can play roles in strengthening society and building capacity with which to resist natural hazard. Innovative development policy is required for those instances where natural hazard coincides with high rates of illness.

#### **Goal 7: Ensuring environmental sustainability**

This goal is to be achieved through the integration of principles of sustainable development into national policies and programmes, thus reversing the loss of environmental resources; by halving, by 2015 the proportion of people without sustainable access to safe drinking water, and by achieving a significant improvement in the lives of at least 100 million slum dwellers. The link between environmental degradation and disaster occurrence is very obvious; for example, deforestation and soil erosion increase mudslides, landslides and flash flooding, while desertification increases drought and famine.

We can mainstream many good practices into projects to sustain the environment, thus preventing disaster or at least mitigating its impact when it inevitably occurs.

#### **Goal 8: Developing a global partnership for development**

The most important components of this goal relate to trade, debt relief and aid. Success rests to a large extent the willingness of developed countries to meet their commitments. More progress has been made in debt relief under the Heavily Indebted Poor Countries (HIPC) initiative.

In forefront for linking disaster risk reduction and sustainable development is the UN Institute of International Strategy for Disaster Reduction (ISDR). The ISDR has succeeded in building regional and international partnerships for disaster risk reduction and disseminating good practice.

## IV. CONCLUSION

Both natural and man-made disasters occur as a result of the failure of the built environment to structurally, functionally, environmentally and socially resist the physical forces of natural hazards and to provide the functional support necessary for recovery. The effects of natural and man-made disasters are usually in the form of loss of lives, property damage and socio-economic disruption.

For development to be sustainable, risk to disaster reduced, emergency management to be successful, environmental consideration must be a central part of decision-making process of government and industry. Environmental protection requires collective action. For this to happen, decisions about economic development ought to take account of the costs of environmental degradation, potential pollution and waste, vulnerability to hazard, mitigation and responding to hazards, and the value of response that are consumed, and conversely of the value of any environmental improvements to be made. Thus, key objective of risk reduction and sustainable development policy is to ensure that environmental costs and benefits are, properly and fully taken into account in public and private sector decisions.

Finally, in order to translate sustainable development principles into disaster risk reduction practices, several requirements must be met. The requirements: are better information is needed about environmental impacts, development of suitable mechanisms in the private sector to ensure that information is brought to bear on the decisions being taken, and brought fully into the decision making process, placing greater emphasis on resource efficiency, and making environmental considerations a central part of the decision-making process within government and industry.

## REFERENCES

- [1] Bruntland, G.H (1987). "Our Common Future"; The Report of the World Commission on Environment and Development: (The Bruntland Commission). Oxford University Press, Oxford.
- [2] Bruntland, G.H (1991), "Our Common Future". Oxford University Press, Oxford  
Christiansen, K (1991). "Possibilities and Limitations to Life Cycle Analysis in Packaging and the Environment-Policies, Strategies and Instruments". International Expert Seminar, Trolleholm Castle, Sweden. Febuary, 7-8.
- [3] Daly, H (1996). "Beyond Growth: The Economics of Sustainable Development". Beacon Press, Boston.
- [4] Hatcher, R.L (1999). "Sustainable Development-OECD Policy for the 21st Century". Environmental Development and Sustainability". Vol 1. No. 1, Pp 96-107
- [5] Henderson, L.J (2004). "Emergency and Disasters: Pervasive Risk and Public Bureaucracy in Developing Nations". Public Organization Review: A Global Journal. 4: 103-119.
- [6] Hornsby, A.S (1995). "Oxford Advanced Learner's Dictionary of the Current English (5th Edition)". Edited by Jonathan Crowther. Oxford University Press. Oxford United Kingdom.
- [7] ISDR (2004). "Editorial; Disaster Reduction in Africa": International Strategy for Disaster Reduction (ISDR) Informs Issue 4, 2004.
- [8] ISDR (2005). "Hyogo Framework of Action 2005-2015: Building the Resilience of Nations and Communities to Disasters". World Conference on Disaster Reduction, 18-22 January 2005, Kobe-Hyogo, Japan.
- [9] Mashi, A.S (2005). "Risk Reduction and Sustainable Development". Paper Presented at The Proceedings of National Platform for Stakeholders in Disaster Reduction Held in Abuja, 13-14 October, 2005. Pp 150-164.
- [10] Moreno, E.L (2001). UNHCS Habitat- From Relief to Development: Some Lessons from the African Experience. United Nations Commission for Human Settlements, New York.
- [11] Ojo, E.O (2005). "Institutionalising Disaster Risk in Ilesha Local Government, Osun State, Nigeria". Paper Presented at the Proceedings of National Platform for Stakeholders in Disaster Reduction Held in Abuja, 13-14 October, 2005. Pp26 - 40.
- [12] Olokesusi, F. (2004). "The Vulnerability Situation and Emergency Management in Nigeria". Paper Presented at the maiden National Conference of Directors and Heads of Disaster Management Organizations in Nigeria. National Emergency Management Agency, held in Abuja. 6 -7 July.
- [13] Ote, H.U (2005). "The Role of Advocacy, Public Enlightenment and Education for Effective Disaster Reduction in States: Example of Ebonyi State". Paper Presented at The Proceedings of National Platform for Stakeholders in Disaster Reduction held in Abuja, 13-14 October, 2005. Pp 117-123.
- [14] Otero, R.C and Marti, R.Z (1995). "The Impacts of Natural Disasters on Developing Economies: Implications for the International Development and Disaster Community". In: Clarke, C.L and M, Munasingbe (eds.) Disaster Prevention For Sustainable Development: Economic and Policy Issues. The International Decade for Natural Disaster Reduction (IDNDR) And The World Bank, Washington D.C. Pp 17-22.
- [15] Response (2002). "The Habitat Agenda and Relevance to Disaster Management". Response Magazine Vol. 1. No. 14
- [16] Serageldin, I. (1995). Promoting Sustainable Development Toward a Paradigm In Serageldin, I.M and Steer, A (eds.) Valuating the Environment. First Annual International Conference on Environmentally Sustainable Development. The World Bank, 1995, Washington D.C
- [17] Tearfund (2005). "Before Disaster Strikes". Annual Report of Tearfund Organization London, United Kingdom.
- [18] UNDP (1987), "Governance for Sustainable Development". United Nations Development Programme, New York.
- [19] UNECD (1987). "Sustainable Development: A Guide to our Common Future". The Report on World Commission on Environment and Development. Oxford University Press, Oxford.
- [20] UNICEF (1986). "Assisting Emergencies: A Resource Handbook for United Nations Children Education Fund Field Staff". Switzerland: UNICEF, New York
- [21] UN/ISDR (2004), "Disaster Risk Reduction, Governance and Development:
- [22] International Strategy for Disaster Risk Reduction (ISDR)". Africa Educational Series, Volume 2, Issue 4.
- [23] UN/ISDR (2004), "Poverty Reduction and Disaster Risk Reduction: International Strategy for Disaster Risk Reduction (ISDR)". Africa Educational Series, Volume 2, Issue 5.
- [24] United Kingdom Strategy (1994). "Sustainable Development Strategy", Oxford University Press, London
- [25] United Nations (2000)". United Nations Millennium Declaration, General Assembly Resolution/RE/55/2. 18 September, P.6.
- [26] Van Nierkerk, D. (2004), "Disaster Reduction and Sustainable Development in Ayeni, B. and Ojo, E.O (eds)". Proceedings of National Conference of Directors and Heads of Disaster Management Organizations in Nigeria. National Emergency Management Agency, Abuja.
- [27] World Health Organization ,(2003). "WHO, Africa Malaria Report 2003". Geneva.
- [28] World Health Organization, ((2004). "WHO, Global Tuberculosis Control Report".

## AUTHORS

**First Author** – Kawuwa, A.S (Mnia), Department Of Architecture, Abubakar Tafawa Balewa University, Bauchi, Nigeria.

**Second Author** – Adamu, S.J, Department Of Geography, Gombe State University, Gombe, Nigeria

**Third Author** – Umar, A.T, Department Of Biological Sciences, Gombe State University, Gombe, Nigeria



# Effect of Different Types of Organic Manure and Mulching on the Growth and Yield of Carrot (*Daucus Carota L.*)

H. E. M. Khairul Mazed<sup>1</sup>, Md. Ashraf Islam Pulok<sup>2</sup>, Md. Shah Newaz Chowdhury<sup>3</sup>, Jannatul Ferdous Moonmoon<sup>4</sup> and Nur-unnaahar<sup>5</sup>

<sup>1</sup>Department of Horticulture, Sher-e-Bangla Agricultural University, Dhaka-1207, Bangladesh

<sup>2</sup>Seed Technology Discipline, Sher-e-Bangla Agricultural University, Dhaka-1207, Bangladesh

<sup>3</sup>Department of Agricultural Botany, Sher-e-Bangla Agricultural University, Dhaka-1207, Bangladesh

<sup>4</sup>Department of Agronomy, Sher-e-Bangla Agricultural University, Dhaka-1207, Bangladesh

<sup>5</sup>Department of Genetics and Plant Breeding, Sher-e-Bangla Agricultural University, Dhaka-1207, Bangladesh.

**Abstract-** An experiment was conducted at the Horticulture Farm of Sher-e-Bangla Agricultural University, Bangladesh during the period from November 2013 to March 2014 to study the effect of different types of organic manure (no organic manure, cowdung, compost and litter) and mulching on (non-mulch, water hyacinth, rice straw and black polythene) the growth and yield of carrot. The experiment was conducted in a Randomized Complete Block Design with three replications. Application of organic manure and mulching significantly influenced the growth and yield of carrot. Cowdung resulted in the highest gross yield (39.05 t/ha) whereas, the plants received no organic manure produced the lowest for the same (33.03 t/ha). The highest gross (39.12 t/ha) and marketable (35.79 t/ha) yield was obtained from the black polythene mulch while the lowest was obtained from non mulched plot. Cowdung with black polythene mulch produced the highest yield (42.75 t/ha) followed by that of application of litter with black polythene mulch (41.46 t/ha). The lowest (32.00 t/ha) was recorded from the control.

**Index Terms-** Carrot, organic manure, mulch, growth and yield

## I. INTRODUCTION

Carrot (*Daucus carota L.*) is one of the most ancient vegetables. It is grown in spring, summer and autumn in temperate countries and during winter in tropical and subtropical countries [1]. Carrot is a member of the family Apiaceae [2] and said to be originated in Mediterranean region and its cultivation as a crop also began in that region [3]. Carrot contains appreciable amount of carotene, thiamin and riboflavin [4]. It is also an excellent source of iron, vitamin-B, vitamin-C and sugar [5]. It can play an important role to protect the blindness in children providing vitamin-A. Furthermore, carrot has some important medicinal values [6,1].

Carrot grows successfully in Bangladesh during rabi season and mid November to early December is the best time for its cultivation to get satisfactory yield [7]. The area under carrot cultivation was 899 thousand hectares with total production of 19374 thousand tones in the world [8]. Rashid and Sarker [9] mentioned an average yield of 35 t/ha of carrot. This production is relatively low compared to other carrot producing countries

like, Israel, UK and Sweden where the yield are reported to be 61.538, 57.683 and 54.348 t/ha, respectively [8].

The cultivation of carrot requires an ample supply of plant nutrient. Use of organic manures essential for its proper growth and development. Supply of organic manure improve soil structure as well as increases its water holding capacity. It facilitates aeration in soil. Recently organic farming is appertained by consumers as it enhances quality of the produce. Inorganic cultivation leaves residual effect in crops which is behind to cause hazard to public health and environment. In Bangladesh carrot is grown during winter season when rainfall is scanty. Irrigation is essential for increased crop cultivation. But it increases cost of production. Under such condition, mulching may be practice in crop cultivation which can replace irrigation to minimize cost of production. Mulch is again highly effective in checking evaporation and is hence recommended for most home garden use of valued crops [10]. It stimulates microbial activity in soil through improvement of agro-physical properties. Mulching increases yield in many horticultural crops like potato, sweet potato, carrot and ginger [11,12,13]. Considering the above facts, an experiment was undertaken to study the effect of different types of organic manure and mulching on growth and yield of carrot cv. New Kuroda.

## II. MATERIALS AND METHODS

The experiment was conducted at the Horticulture Farm, Sher-e-Bangla Agricultural University, Dhaka, Bangladesh during the period from November 2013 to March 2014 to study the effect of different types of organic manure (no organic manure, cowdung, compost and litter) and mulching on (non-mulch, water hyacinth, rice straw and black polythene) the growth and yield of carrot. The location of the experimental site was at 23.74° N latitude and 90.35° E longitudes with an elevation of 8.45 meter from the sea level. Soil of the study site was silty clay loam in texture. The area represents the Agro-Ecological Zone of Madhupur tract (AEZ-28) with pH 5.8-6.5, ECE 25.28.

The seeds of carrot cv. New Kuroda, a Japanese variety, were used in the experiment. The seeds were produced and packed by Takii and Co. Ltd. Kyoto, Japan. The experiment



consisted of two factors which are as follows: Factor A: Organic manure:  $O_0$  = Control (no organic matter),  $O_1$  = Cowdung (25 t/ha),  $O_2$  = Compost (35.00 t/ha) and  $O_4$  = Litter (24.00 t/ha) and Factor B: Mulching material:  $M_0$  = Control (no mulching material),  $M_1$  = Water hyacinth,  $M_2$  = Rice straw and  $M_3$  = Black Polythene. The two-factor experiment was laid out following Randomized Complete Block Design (RCBD) with three replications. There were 48 unit plots altogether in the experiment. The size of each plot was 1.5 × 1 m. The distance between blocks and between plots were kept respectively 1 and 0.5 m. The following doses of manures and fertilizers were recommended for carrot production by Rashid and Shakur [9]. The seeds were soaked in water for 24 hours and then wrapped with piece of thin cloth. The treated seeds were sown in field on 29 November 2013. Mulches of water hyacinth and straw were applied immediately after seed sowing while that of black polythene sheet with small holes at proper spacing was spreaded over the plot before seed sowing and emerged easily through the holes. The crop was harvested on 19 March 2014 i.e. after 105 days after sowing (DAS).

Ten plants were sampled randomly from each unit plot for the collection of per plant data. The data collected from the experimental plots were statistically analyzed. The mean value for all the treatments was calculated and the analysis of variance for most of the characters was accomplished by F variance test. The significance of difference between pair of means was tested by the Least Significant Difference (LSD) test at 5% and 1% level of probability [14].

### III. RESULTS AND DISCUSSION

#### Plant height

Plant height varied significantly due to the application of different organic manure at harvest time (105 DAS) (Table 1). The highest plant height (42.43 cm) was found from  $O_1$  (cowdung) and the lowest plant height (25.36 cm) was recorded from  $O_0$  (control treatment). The plant height varied also significantly due to different types of mulching practices at harvest time (105 DAS) (Table 1). The highest plant height (43.00 cm) was found from  $M_3$  (black polythene mulch) and the lowest plant height (28.81 cm) was recorded from  $M_0$  (control treatment). Maity *et al.* [15] in their experiment reported that mulch increased the plant growth and yield of ginger.

The plant height was significantly influenced by the combined effect of organic manure and mulching at harvest time (105 DAS) (Table 1). The highest plant height (48.10 cm) was found from  $O_3M_3$  (litter with black polythene mulch) but statistically same (49.51 cm)  $O_1M_3$  (cowdung with black polythene mulch) and the lowest (21.29 cm) from  $O_0M_0$  (control treatment).

#### Number of leaves per plant

Application of organic manure increased the number of leaves per plant significantly at harvest time (105 DAS) (Table 1). The highest number of leaves per plant (12.27) was found from  $O_1$  (cowdung) and the lowest (9.85) was recorded from  $O_0$  (control treatment). The number of leaves per plant varied also significantly due to different types of mulching practices at harvest time (105 DAS) (Table 1). The highest number of leaves

per plant (12.27) was found from  $M_3$  (black polythene mulch) and the lowest (10.25) was recorded from  $M_0$  (control treatment).

The number of leaves per plant was significantly influenced by the combined effect between organic manure and mulching at harvest time (105 DAS) (Table 1). The highest number of leaves per plant (13.10) was recorded from  $O_1M_3$  (cowdung and black polythene mulch) and the lowest number of leaves per plant (9.00) was observed from  $O_0M_0$  (control treatment).

#### Dry matter percent of leaves

Organic manure had significant effect on dry matter of leaves per plant (Table 1). The highest dry matter of leaves (16.13%) was recorded from  $O_1$  (Cowdung) and the lowest dry matter (13.17%) was recorded from  $O_0$  (control treatment). Dry matter of leaves was significantly influenced by different mulches (Table 1). The highest dry matter of leaves (16.09%) was recorded from  $M_3$  (black polythene) and the lowest dry matter of leaves (14.26%) was found from  $M_0$  (control treatment).

The combined effect of different organic manure and mulching on percentage of dry matter of leaves was significant (Table 1). The highest dry matter (18.00%) was obtained from  $O_1M_3$  (cowdung with black polythene) and the lowest (12.65%) was found from  $O_0M_0$  (Control treatment).

#### Length of root

The length of carrot root was found to be statistically significant due to the effect of organic manure (Table 1). The longest root (16.49 cm) was obtained from  $O_1$  (cowdung) and the shortest (14.07 cm) was from  $O_0$  (control treatment). Significant influence was observed due to the effect of mulching on the length of root (Table 1). The longest root (16.44 cm) was obtained from  $M_3$  (black polythene mulch) and the lowest root length (14.64 cm) was found from  $M_0$  (control treatment).

The interaction effect between organic manure and mulching treatment was significant (Table 1). The combined effect of  $O_1M_3$  (cowdung with black polythene mulch) gave the longest (17.42 cm) root and the shortest (13.07 cm) length of root was obtained from  $O_0M_0$  (control treatment).

#### Diameter of root

Diameter of carrot root was significantly influenced by the application of organic manure (Table 1). The highest diameter (4.73 cm) was obtained from  $O_1$  (cowdung) and the lowest diameter (3.24 cm) was obtained from  $O_0$  (control treatment). Diameter of carrot roots was significantly influenced by mulching (Table 1). The maximum root diameter (4.70 cm) was obtained from  $M_3$  (black polythene mulch) and the lowest root diameter (3.62 cm) was obtained from  $M_0$  (control treatment).

Root diameter varied significantly due to combined effect of organic manure and mulching (Table 1). The maximum thickness of root (5.54 cm) was found from  $O_1M_3$  (cowdung with black polythene mulch) and the minimum (2.92 cm) was recorded from  $O_0M_0$  (control treatment).

**Table 1. Effect of different organic manure and mulching treatment on growth of carrot**

[29]	Treatment	Plant height	Number of	Dry matter	Root length	Diameter of	
[30]	Dry matter	(cm)	leaves per	of leaves	per plant	root per plant	
[31]	of root		Plant	(%)	(cm)	(cm)	
	(%)						
[32]	<b>Organic manure</b>						
[33]	0 <sub>0</sub>	25.36 c	9.85 b	13.17 d	14.07 d	3.24 d	9.68
[34]	0 <sub>1</sub>	42.43 a	12.27 a	16.13 a	16.49 a	4.73 a	11.19
[35]	0 <sub>2</sub>	38.62 b	11.75 a	15.30 c	15.85 c	4.24 c	10.79
[36]	0 <sub>3</sub>	41.00 a	12.03 a	15.78 b	16.22 b	4.48 b	11.07
[37]	LSD <sub>(0.05)</sub> 0.074	2.300	1.021	0.337	0.146	0.091	0.091
[38]	<b>Mulch material</b>						
[39]	M <sub>0</sub>	28.81 d	10.25 c	14.26 d	14.64 d	3.62 d	10.07
[40]	M <sub>1</sub>	40.77 b	12.02 a	15.20 b	16.09 b	4.37 b	10.98 b
[41]	M <sub>2</sub>	34.90 c	11.35 b	14.83 c	15.46 c	4.01 c	10.47 c
[42]	M <sub>3</sub>	43.00 a	12.27 a	16.09 a	16.44 a	4.70 a	11.22 a
[43]	LSD <sub>(0.05)</sub> 0.074	2.012	0.622	0.337	0.146	0.091	0.091
[44]	<b>Organic manure × Mulch material</b>						
[45]	0 <sub>0</sub> M <sub>0</sub>	21.29 j	9.00 h	12.65 j	13.07 m	2.92 h	9.30
[46]	0 <sub>0</sub> M <sub>1</sub>	26.35 hi	10.00 g	13.23 hi	14.48 k	3.42 I	9.90
[47]	0 <sub>0</sub> M <sub>2</sub>	24.01 ij	10.01 g	13.03 i	14.03 l	3.11 j	9.50
[48]	0 <sub>0</sub> M <sub>3</sub>	29.81 gh	10.40 g	13.79 h	14.72 j	3.52 I	10.04
[49]	0 <sub>1</sub> M <sub>0</sub>	32.15 fg	10.90 e	15.00 fg	15.47 h	4.12 g	10.48
[50]	0 <sub>1</sub> M <sub>1</sub>	47.05 ab	12.90 ab	16.03 c	16.93 b	4.88 c	11.51
[51]	0 <sub>1</sub> M <sub>2</sub>	41.01 cd	12.20 bc	15.50 c-e	16.12 ef	4.40 e	10.95 e
[52]	0 <sub>1</sub> M <sub>3</sub>	49.51 a	13.10 a	18.00 a	17.42 a	5.54 a	11.84
[53]	0 <sub>2</sub> M <sub>0</sub>	30.75 g	10.60 ef	14.59 g	14.93 ij	3.63 h	10.17 i
[54]	0 <sub>2</sub> M <sub>1</sub>	43.35 bc	12.50 a-c	15.60 c-e	16.33 de	4.53 de	11.14
[55]	0 <sub>2</sub> M <sub>2</sub>	35.80 ef	11.30 de	15.31 d-f	15.73 g	4.22 fg	10.64
[56]	0 <sub>2</sub> M <sub>3</sub>	44.60 bc	12.60 ab	15.70 cd	16.40 cd	4.60 d	11.20
[57]	0 <sub>3</sub> M <sub>0</sub>	31.05 g	10.53 fg	14.81 fg	15.12 l	3.81 h	10.34
[58]	0 <sub>3</sub> M <sub>1</sub>	46.33 ab	12.70 ab	15.93 cd	16.62 c	4.66 d	11.35

[59]	O <sub>3</sub> M <sub>2</sub>	38.80 de	11.90 cd	15.49 c-e	15.94 fg	4.31 f	10.80
	f						
[60]	O <sub>3</sub> M <sub>3</sub>	48.10 a	13.00 a	16.90 b	17.22 a	5.16 b	11.80
	a						
[61]	LSD <sub>(0.05)</sub>	3.752	0.743	0.675	0.293	0.182	
	0.149						
[62]	CV (%)	4.73	3.84	3.76	5.92	4.54	6.75

### Dry matter percent of root

The per cent dry matter of root also varied significantly by organic manure (Table 1). The highest dry matter of roots (11.19%) was recorded to O<sub>1</sub> (cowdung) and the lowest dry matter of roots (9.68%) was obtained from O<sub>0</sub> (control treatment). Application of mulch materials showed significant influence on the per cent dry matter of root (Table 1). The highest dry matter of root (11.22%) was found M<sub>3</sub> (black polythene mulch) and the lowest (10.07%) was found M<sub>0</sub> (control treatment).

Significant combined effect of organic manure and mulching was observed on dry matter percentage of roots (Table 1). The highest dry matter of roots (11.84%) was observed in O<sub>1</sub>M<sub>3</sub> (cowdung with black polythene mulch) and the lowest dry matter (9.30 %) was recorded from O<sub>0</sub>M<sub>0</sub> (control treatment).

### Cracking percentage of roots

Organic manure had significant effect on the cracking percentage of roots (Table 2). The highest percentage of root cracking (5.05%) was observed from O<sub>1</sub> (cowdung) and the lowest percentage of root cracking (3.42%) was found O<sub>0</sub> (control treatment). The percentage of cracked roots production of carrot was significantly influenced by the different types of mulching treatments (Table 2). The highest percentage of root cracking (5.07%) recorded from M<sub>3</sub> (black polythene mulch) and the lowest percentage of root cracking (3.74%) was found M<sub>0</sub> (control treatment).

Root cracking varied significantly due to combined effect of organic manure and mulching (Table 2). The highest cracked root (5.76%) was recorded from O<sub>1</sub>M<sub>3</sub> (cowdung with black polythene mulch) and the lowest (2.5%) was observed from O<sub>0</sub>M<sub>0</sub> (control treatment).

### Rotting percentage of roots

The percentage of rotting of roots was significantly affected by the organic manure treatment (Table 2). The highest rotting percentage of roots (3.34%) was recorded O<sub>1</sub> (cowdung) and the lowest rotting percentage (1.54%) was observed O<sub>0</sub> (control treatment).

The percentage of rotting roots of carrot was significantly affected by the mulching treatments (Table 2). The highest rotting percentage of roots ((3.24%) was recorded from M<sub>3</sub> (black polythene mulch) and the lowest rotting percentage (2.38%) was observed M<sub>0</sub> (control treatment).

The combined effect of organic manure and mulching was observed on rotting percentage of roots (Table 2). The highest percentage of rotten root (3.97%) was recorded from O<sub>3</sub>M<sub>3</sub> (litter with black polythene mulch) but statistically similar result (3.89%) given O<sub>1</sub>M<sub>3</sub> (cowdung with black polythene mulch) and the lowest (1.13%) was obtained from O<sub>0</sub>M<sub>0</sub> (control treatment).

### Fresh weight of root per plant

The fresh weight of root per plant significantly differed with organic manure treatments (Table 2). The maximum fresh weight of root (146.50 g) was recorded from O<sub>1</sub> (cowdung) and the lowest fresh weight of root (123.96 g) was recorded from O<sub>0</sub> (control treatment). The fresh weight of root per plant significantly differed with mulching (Table 2). The highest fresh weight of root (146.74 g) was recorded from M<sub>3</sub> (black polythene mulch) and the lowest fresh weight of root (128.65 g) was recorded from M<sub>0</sub> (control treatment).

A significant combined effect of organic manure and mulching was observed on fresh weight of root per plant (Table 2). The maximum (160.35 g) fresh weight of root was recorded from O<sub>1</sub>M<sub>3</sub> (cowdung with black polythene mulch) and the minimum (120.14 cm) was found from O<sub>0</sub>M<sub>0</sub> (control treatment).

### Gross yield of roots per plot

Statistically significant variation due to different organic manure were found in gross yield of roots per plot (Table 2). The maximum gross yield per plot (5.85 kg) was obtained from O<sub>1</sub> (cowdung) and the minimum (4.95 kg) was recorded from O<sub>0</sub> (control treatment). The yield of carrot root per plot was found to be statistically significant due to the effect of mulching (Table 2). The highest yield (5.86 kg) was recorded M<sub>3</sub> (black polythene mulch) and the lowest root yield (5.14 kg) was recorded from M<sub>0</sub> (control treatment).

The interaction of different organic manure and mulching was found to be significant on gross yield of root per plot (Table 2). The maximum gross yield per plot (6.41 kg) was found from O<sub>1</sub>M<sub>3</sub> (cowdung with black polythene mulch) and the minimum

gross yield of root (4.80 kg) was recorded from O<sub>0</sub>M<sub>0</sub> (control treatment).

**Table 2. Effect of different organic manure and mulching treatment on yield of carrot**

Treatment	Fresh weight	Gross yield	Marketable yield	Root
Root	of root per plant	of root per plot	of root per plot	cracking
rotting	(g)	(kg)	(kg)	(%)
(%)				
<b>Organic manure</b>				
O <sub>0</sub>	123.96 d	4.95 d	4.71 d	1.54 d
O <sub>1</sub>	146.50 a	5.85 a	5.59 a	3.34 a
O <sub>2</sub>	138.65 c	5.54 c	5.18 c	2.99 c
O <sub>3</sub>	143.07 b	5.72 b	5.24 b	3.26 b
LSD <sub>(0.05)</sub>	0.481	0.026	0.026	0.186
<b>Mulch material</b>				
M <sub>0</sub>	128.65 d	5.14 d	4.82 d	2.38 d
M <sub>1</sub>	141.80 b	5.67 b	5.23 b	2.88 b
M <sub>2</sub>	134.99 c	5.39 c	5.01 c	2.63 c
M <sub>3</sub>	146.74 a	5.86 a	5.37 a	3.24 a
LSD <sub>(0.05)</sub>	0.481	0.026	0.026	0.186
<b>Organic manure × Mulch material</b>				
O <sub>0</sub> M <sub>0</sub>	120.14 n	4.80 n	4.62 m	1.13 h
O <sub>0</sub> M <sub>1</sub>	125.37 m	5.01 m	4.79 k	1.61 fg
O <sub>0</sub> M <sub>2</sub>	124.74 m	4.98 m	4.73 l	1.52 g
O <sub>0</sub> M <sub>3</sub>	125.60 m	5.02 m	4.73 l	1.91 f
O <sub>1</sub> M <sub>0</sub>	134.85 j	5.38 j	4.99 l	2.80 e
O <sub>1</sub> M <sub>1</sub>	150.63 c	6.02 c	5.48 c	3.60 ab
O <sub>1</sub> M <sub>2</sub>	140.18 g	5.60 g	5.16 g	3.10 cd
O <sub>1</sub> M <sub>3</sub>	160.35 a	6.41 a	5.79 b	3.89 a
O <sub>2</sub> M <sub>0</sub>	128.77 l	5.14 l	4.79 k	2.90 de
O <sub>2</sub> M <sub>1</sub>	143.45 f	5.73 f	5.27 f	2.93 de
O <sub>2</sub> M <sub>2</sub>	136.87 i	5.46 i	5.06 h	2.93 de
O <sub>2</sub> M <sub>3</sub>	145.53 e	5.82 e	5.34 e	3.20 c
O <sub>3</sub> M <sub>0</sub>	130.85 k	5.23 k	4.87 j	2.70 e
O <sub>3</sub> M <sub>1</sub>	147.75 d	5.91 d	5.40 d	3.40 bc
O <sub>3</sub> M <sub>2</sub>	138.19 h	5.52 h	5.10 h	3.00 d
O <sub>3</sub> M <sub>3</sub>	155.50 b	6.22 b	6.61 a	3.97 a
LSD <sub>(0.05)</sub>	0.963	0.052	0.052	0.372
CV (%)	2.73	8.43	5.82	3.62

**Marketable yield of roots per plot**

The marketable yield of carrot root per plot was found to be statistically significant due to effect of organic manure (Table 2). The highest marketable yield (5.59 kg/plot) of root per plot was recorded from O<sub>1</sub> (cowdung) and the lowest marketable yield (4.71 kg) was recorded from O<sub>0</sub> (control treatment). Marketable yield of roots per plot varied significantly due to different mulch treatments (Table 2). The highest marketable yield of root (5.37 kg/plot) was obtained from M<sub>3</sub> (black polythene mulch) and the

lowest yield (4.82 kg/plot) was recorded from M<sub>0</sub> (control treatment).

The combined effect of marketable yield of root per plot was significantly influenced by organic manure and mulching treatments (Table 2). The highest marketable yield of root per plot (6.61 kg) was observed from O<sub>3</sub>M<sub>3</sub> (litter with black polythene mulch) and the lowest yield (4.62 kg) was obtained from O<sub>0</sub>M<sub>0</sub> (control treatment).

#### IV. CONCLUSION

Different types of organic manure and mulching had significant combined effects of plant height at all other dates of observations. The highest total yield and marketable yield of carrot root was recorded from 6.41 kg/plot, 42.75 t/ha and 6.61 kg/plot, 38.61 t/ha the application of cowdung with black polythene mulch treatment.

**Fourth Author:** Jannatul Ferdous Moonmoon, B. Sc. Ag. (hons), Sher-e-Bangla Agricultural University, Dhaka-1207, Bangladesh.

**Fifth Author:** Nur-unnaahar, B. Sc. Ag. (hons), Sher-e-Bangla Agricultural University, Dhaka-1207, Bangladesh, E-mail: nur\_unnaahar@yahoo.com.

#### REFERENCES

- [1] Bardy, N. C. 1990. The Nature and Properties of Soils. 10 Edn. Mc Millan Pub. Co. New York. pp. 173-410.
- [2] Prince, L. C. 1987. Vegetable: characteristics, production and marketing. John Wiley and Sons. Inc., New York. pp. 251-252.
- [3] Shinohara, S. 1984. Vegetable seed production of Japan. Vol. 1. Shinohara Authorized Agricultural consulting Engineer officer, 4-7-7 N. Nishiri, Shingapore-ku, Tokyo. pp. 123-142.
- [4] Sharfuddin, A. F. M. and Siddique, M. A. 1985. Sabjee Biggan. Ist Edn. Mrs. Hasina Akter Beauty, Bangladesh Agricultural University, Mymensingh. P.11.
- [5] Yawalkar, K. S. 1985. Vegetable crops in India. Third Edn. Mrs. Yawalkar, Agric-Horticultural Publishing House, 52, Bajaj Nagar. 440010. pp. 210-220.
- [6] Razzak, A. and Ahmed, K. 1973. A comparative study on the performance of some varieties of carrot. Bangladesh Hort., 1(2): 82-83.
- [7] Rashid, M. M. 1993. Sabjibijnan, Ist Edn. Golam Moyenuddin, Director, Text Book Division, Bangla Academy, Dhaka. pp. 502-507.
- [8] FAO. 2000. Production Yearbook. Food and Agriculture Organization, Rome, Italy. 54: 160-161.
- [9] Rashid, M. M. and Shakur, M. A. 1986. Effect of planting and duration of growing period on the yield of carrot. Bangladesh Hort., 14(2): 28-32.
- [10] Bardy, N. C. 1990. The Nature and Properties of Soils. 10 Edn. Mc Millan Pub. Co. New York. pp. 173-410.
- [11] Kim, S. Y. Ryu, O. H. and Hahm, B. H. 1988. The effect of transparent polythene film mulch on the soil temperature, potato growth and yield of the spring crop Reports of Rural Development-Administration-Horticulture- Korea Republic, 30:292-98. [Cited from Field Crop Abstr., 42(10): 8125, 1989].
- [12] Choudhury, M. S. H., Siddique, M. A. and Rabbani, M. G. 1993. Irrigation and mulching effect on sweet potato yield. Bangladesh Hort., 21(1): 43-47.
- [13] Jaiswal, J. P., Subedi, P. P. and Gurung, H. M. 1996. Fertilizer trail on carrot connected at outreach research sites for off-season production working paper. Lumle. Res. Centre, Kaksi, Nepal. 24: 96-103.
- [14] Gomez, K. A. and Gomez, A. A. 1984. Statistical Procedures for Agricultural Research. Second Edn. A Wiley-Inter Science publication, John Wiley and sons, New York. p. 680.
- [15] Maity, B. R., Mandal, A. H., Roy, S.G. and Mandal, A. 2001. Growth and sporulation of *Aternaria radiciana* under various carbon and nitrogen sources. J. Mycopathological Res., 39(1): 49-51]

#### AUTHORS

**First Author:** H. E. M. Khairul Mazed, B. Sc. Ag. (hons), Sher-e-Bangla Agricultural University, Dhaka-1207, Bangladesh, E-mail: hemkhairulmazed@gmail.com.

**Second and Corresponding Author:** Md. Ashraful Islam Pulok, B. Sc. Ag. (hons), Sher-e-Bangla Agricultural University, Dhaka-1207, Bangladesh, E-mail: kbdpulok@gmail.com.

**Third Author:** Md. Shah Newaz Chowdhury, B. Sc. Ag. (hons), Sher-e-Bangla Agricultural University, Dhaka-1207, Bangladesh, E-mail: Shoaibchowdhury413@gmail.com.



# Comparison of the use of single lung ventilation Vs both lung ventilation in Video Assisted thoracoscopy

MVG Pinto<sup>1</sup>, KB Galketiya<sup>2</sup>

\*Consultant anaesthetist/ senior lecturer, Faculty of medicine, University of Peradeniya, Sri Lanka

\*\* Consultant surgeon/ senior lecturer, Faculty of medicine, University of Peradeniya, Sri Lanka

**Abstract-** Lack of availability of medical instruments are frequent limitations in new-fangled surgeries in developing countries. Video-assisted thoracic surgery usually performed with Single lung ventilation (SLV) using a double lumen tube, at times lack of double lumen tubes necessitated the use of single lumen tubes with 'double lung ventilation' (DLV). The lack of evidence for the surgical and anaesthetic feasibility of the use of DLV dictated a review enabling a comparison with DLV for similar surgical procedures.

Both SLV and DLV provided adequate space for surgery. The changes in the cardio-respiratory parameters were similar during both as was blood loss. The insufflations pressures and the volumes of CO<sub>2</sub> required were similar.

The positive observation of easier re-expansion of the lung was noted in DLV. There were no unexpected post-operative complications following either mode of ventilation.

A single lumen endotracheal tube is a safe and effective alternative for VATs.

**Index Terms-** thoracoscopy, single lung ventilation, double lung ventilation

## I. INTRODUCTION

Many medical institutions in developing and lower middle income countries constrains associated with equipment. As the Single lung ventilation (SLV) is the preferred mode of ventilation for patients undergoing thoracic endoscopic surgeries, lack of double lumen endotracheal tubes necessitates double lung ventilation (DLV). Data on the adequacy of surgical access and adverse effects on ventilation and cardiac output and effects of both lung ventilation in these surgeries are very scarce. We presents our observations on the surgical access, cardiorespiratory effects, the time, the risk of converting to open surgery, CO<sub>2</sub> usage with regards to its effects and excretion, the insufflation pressures used when DLV was a necessity. The procedures are compared when surgery was carried out using SLV.

In open surgery, Once the intrinsic negative pleural pressure dynamic is breached, the lung collapses and retracts toward the hilum due to intrinsic elasticity.<sup>1</sup>, creating an Open pneumothorax. compared to this In VATs the creation of Carbon dioxide tension simulate the effects of tension

pneumothorax. This theoretically can lead to rise in intrathoracic pressure and reduces venous return, pulmonary blood flow and increases right heart workload<sup>2</sup>

In DLV carbon dioxide needs to be insufflated initially and intermittently into the chest cavity in contrast to Initial insufflation in SLV. Thus the total volume of CO<sub>2</sub> and the required insufflation pressures may be different. This effect can compress the ventilating lung in DLV instead of non ventilated lung as in SLV which may have adverse respiratory and cardiovascular effects.

The degree of lung collapse obtained in DLV should be adequate to provide space for instrumentation and dissection. In addition another issue to consider is the ongoing suction during surgery which has a tendency to get the lung to re expanded hindering dissection which is not a problem in SLV.

## II. METHOD

A prospective study with data collected from patients who underwent VATS with DLV and SLV at the surgical unit, Teaching Hospital, Peradeniya are reported.

At the site of camera port an incision was made and dissected until pleural cavity is entered using a scissor. This induces a small pneumothorax preventing any lung damage when the camera port is pushed in. CO<sub>2</sub> insufflation was started initially to build a pressure of 6mmHg. The camera is introduced and the degree of lung collapse and mediastinal anatomy was inspected. Then two working ports were introduced. Gentle compression with instruments also facilitate lung collapse. Respiratory and cardiovascular parameters were monitored throughout the procedure. The gas insufflation pressure was increased until adequate lung collapse is achieved, while monitoring vital parameters. The insufflation pressure and the volume of CO<sub>2</sub> required to obtain the lung collapse were noted. The total volume of CO<sub>2</sub> required for the entire procedure was also recorded. The adequacy of space obtained for instrumentation and dissection was noted. The need for retractors was assessed. The space provided is reflected by safe completion of the procedure. As indices of this time for surgery, blood loss and conversion to open surgery were recorded.

## III. RESULTS

**Table 1- procedures with the position and the mode of ventilation, the mean time blood loss, use of additional ports for retractors and conversion to open Surgery**

Procedure	SLV	DLV	Position	Average time taken	Additional ports	Mean Blood loss	Conversion
Lymph node dissection	2	-	Supine	4 hr	Nil	150ml	Nil
Thymectomy	2	6	Supine	OLV- 3.5 hr DLV- 3.8 hr	One (OLV)	150ml	Nil
Thoracoscopy assisted excision of retrosternal goiter	-	2	Supine	4.5 hr	One(OLV)	150ml	Nil
Mobilization of thorasic esophagus in three stage esophagectomy	10	5	Prone	OLV- 2.5 hr DLV- 2 hr	Nil	100-150	Nil

**Table 2- The required insufflations pressure, Initial CO<sub>2</sub> volume required to obtain lung collapse and total volume of CO<sub>2</sub>used**

Procedure	SLV	Insufflation s pressure mmHg	Initial CO <sub>2</sub> volume	total volume	DLV	Insufflations pressure	Initial CO <sub>2</sub> volume	total volume
LND	2	6-8			-	-		
THY	2	6-8			6	6-8		
RTHY	-	6-8			2	6-8		
OES	10	6-8			5	6-8		

LND- Lymph node dissection    THY- Thymectomy    RTHY - Retrosternal goiter    OES- esophagectomy

**Table 3- The respiratory and cardiovascular parameters**

a. Respiratory parameters comparing two ventilatory strategies

	Changes from the base line	Peak air way pressures			Saturation change			End Tidal CO <sub>2</sub>			
		1-5	5-10	>10	1-3	3-5	5-10 drop	Red 1-5	Red 5-10	Inc 1-5	Inc 5-10 above
THY	(OLV) 2	2			1	1				2	
	(BLV)6	6			6					6	
OES	(OLV)10	10			7	3				8	2
	(BLV)5	5			5					4	1

THY- Thymectomy    OES- esophagectomy

b. cardiovascular parameters comparing two ventilator strategies-

	Procedure	Heart change Rate			Blood Pressure change (Sys)			Blood Pressure change (Diast )		
		10-20	20-30	30-40	10-20	20-30	30-40 above	10-20	20-25	25-30 above
THY	(OLV)2	2				1	1	2		
	(BLV)6	5	1			6		6		
OES	(OLV)10	6	4		1	4	1	9	1	

	(BLV)5	2	2			5		5		
--	--------	---	---	--	--	---	--	---	--	--

THY- Thymectomy OES- esophagectomy

All the patients' respiratory and cardiovascular parameters were stable and not significantly different in both ventilator strategies during the equivalent procedures

**Surgical team special notes**

In both ventilatory situations the space obtained provided a clear display of the lesion and the related anatomy for a safe dissection. There was adequate room for instrumentation. Only one thymectomy and retrosternal thyroidectomy required a retractor. This was to retract the pathology and not the lung.

A re expansion of the lung during the surgery was experienced with DLV , which could hinder the dissection . But Once this was experienced the cause was identified as suction. The suction of blood /fluid only and not applying the suction too long to the space obviate this setback, and practiced in later cases. However quick re collapse was not identified as a problem .

Another comment was that with DLV the re-expansion of the lung was found to be easier simply by shutting down CO<sub>2</sub>.

**Post Operative period**

One patient with retrosternal goiter who had both lung ventilation was electively ventilated for 24 hrs due to the extent of the resection. All Oesophagectomy patients were ventilated with a range of 2-5 days having both groups mixed up. One patient with OLV and one with BLV had respiratory tract infection and BLV patient had a leak on to the necks and both patients died After two weeks and three weeks respectively. Thymectomy patients were observed in the intensive care unit for 16- 24 hrs no complications detected. Other post esophagectomy patients were discharged from ICU by fourth day. The thymectomy and retrosternal goiter patients were sent to the ward on day one. All other patients were managed in the ward.

**IV. DISCUSSION**

There is a possibility the capnothorax can act like a tension pneumothorax. This is likely as reported by Peden CJ, Prys-Roberts C<sup>7</sup> either the lung deflated too fast or the CO<sub>2</sub> was insufflated too rapidly . Both situations were explained when doing the SLV. In the observations in this study , SLV and DLV both did not caused any adverse changes of cardio – respiratory parameters. In DLV this may be less as the lung is partially collapse by the tcapnothorax. The possible hypoxia explained in the SLV also will be less likely in DLV hence both lungs are ventilated with minimal shunt.

Intraoperative access of DLV was similar with same adjustments with SLV and did not show much deference of the time (Table1). The insufflation pressures showed a slight increase in the pressure used with DLV compared to its equivalent surgery with SLV (Table 2)

In both situations the procedures were performed with minimal blood loss . The important fact to note was there was no requirement of the additional ports for Retractors and no

conversion to open Surgery when using DLV. This indirectly indicates that the space obtained must have provided a clear display of the lesion and the related anatomy for a safe dissection. It was evident that there was adequate room for instrumentation. Only one thymectomy and retrosternal thyroidectomy required a retractor. This was said to be to retract the pathology and not the lung.

In DLV theoretically a high insufflation pressures and volumes are required to partially collapse the lung to provide surgical access. This is not a necessity during SLV . In all cases the maximum insufflation pressure used was 6-8mmHg. But it was pointed out that in long major procedures The CO<sub>2</sub> volume required for initial collapse and the total volume for the procedure was more with double lung ventilation. Though large volumes of CO<sub>2</sub> was used during DLV there was no complications detected ( Airway pressures, Hypercapnoea) during Surgery.

With double lung ventilation it was reported to be possible to simply re-expand the lung by shutting down CO<sub>2</sub> , This may be an advantage in long procedures.

Eventhough there were some complications noted in the post operative period in major procedures like Oesophagectomy it is seems there is no difference between the two ventilatory strategies.

**V. CONCLUSIONS**

The space provided for surgery is not different whether single lung or double lung ventilation was used. The gas insufflations pressure has no significant difference. The total volume of CO<sub>2</sub> used is higher in double lung ventilation but had no adverse out come. Therefore double lung ventilation with a lung collapse induced with a capnothorax of 6-8mmHg can be safely and effectively be used in thoracoscopic surgeries. It will certainly avoid the difficulties encountered with intubation with a double lumen tube and complications of One lung ventilation. It also allows a simple and quick re-expansion of the lung when required.

**REFERENCES**

[1] Cohen H, Benumof JL. Lung separation in the patient with a difficult airway. *Curr Opin Anaesthesiol* 1999;12:29-35.,  
 [2] Wolfer RS, Krasna MJ, Hasnain JU, McLaughlin JS. Hemodynamic effects of carbon dioxide insufflation during thoracoscopy. *Ann Thorac Surg* 1994;58:404-8.  
 [3] Peden CJ, Prys-Roberts C. Capnothorax: implications for the anaesthetist. *Anaesthesia* 1993 Aug;48:664-6  
 [4] Management of patients undergoing oesophagectomy. : The Report of the National Confidential Enquiry into Perioperative Deaths 1996/1997. Compiled by Gray AJ, Hoile RW, Ingram GS, Sherry KS. National CEPOD: London; 1998. p. 57-61.  
 [5] Conacher ID. Pre-emptive analgesia and the paravertebral space: *Br J Anaesth* 2006;96:667-8.  
 [6] Conacher ID. Anesthesia for thoracoscopic surgery. *J Min Access Surg [serial online]* 2007 [cited 2012 Oct 27];3:127-31.)

- [7] Conacher ID. Postoperative pulmonary oedema - tussle with Starlings in the death zone. *Anaesthesia* 2006;61:211-4.
- [8] Tuna Lacin, Scott Swanson. Current cost of Video Assisted Thoracoscopic Surgery, *J Thoracic Disease* . Aug 2013; 5( Suppl): S 190-S193
- [9] J. Christian Cash, Joerg Zehetner, Bobak Hedayati, Nikolai A. Bildzukewicz, Namir Katkhouda, Rodney J. Mason, John C. Lipham Outcomes following laparoscopic transhiatal esophagectomy for esophageal cancer; *Surgical Endoscopy*. Oct 2013
- [10] Luigi Bonavina, Raffaello Incarbone, Davide Bona, and Alberto Peracchia. *Journal of Laparoendoscopic & Advanced Surgical Techniques* . Esophagectomy via Laparoscopy and Transmediastinal Endodissection 14(1): 13-16. February 2004

#### AUTHORS

**First Author** – MVG Pinto, Consultant anaesthetist/ senior lecturer, Faculty of medicine, University of Peradeniya, Sri Lanka

**Second Author** – KB Galketiya, Consultant surgeon/ senior lecturer, Faculty of medicine, University of Peradeniya, Sri Lanka, email-[kbgalketiya@yahoo.com](mailto:kbgalketiya@yahoo.com)  
Telephone-0094777884008

# Austrian German in Teaching the German Language

Valentina Ilieva

PhD, Faculty of Education, Bitola, Macedonia

**Abstract-** The German language and German speaking countries are the center of attention of all teachers of the German language worldwide. Teachers of the German language master the German language in the course of their studies and then they teach it to their students or adult learners. In the process of preparing and giving their lectures they come across a lot of issues and, consequently, they do their utmost to handle them. Understandably, the main reason why both students and adult learners try to master the German language is to be able to communicate effectively with native speakers of the German language in their own country or in the German speaking countries. Bearing in mind the fact that approximately 100 million people speak German, it is not difficult to assume that there are many diverse dialects of the German language. However, this fact is not too alarming as the same is the case with many other languages in the world. What is relevant for the German language are the variants of the German language alongside with terms such as: language community, nation, the German language as an official language, dialect regions, pluricentricity of the German language, national variant, Austrian German and Swiss German etc., as well as to what extent these variants, i.e. Austrian German and Swiss German are necessary in the German language teaching process as a foundation for successful communication with the inhabitants of the Republic of Austria and the German speaking inhabitants of Switzerland, respectively. The German language is spoken throughout the entire territory of the Republic of Austria, which, in return, has turned the Republic of Austria into the national center of the German language. Hence, not surprisingly, the following question emerges: "To what extent does Austrian German differ from the standard German language spoken in the Federal Republic of Germany?". More precisely, this paper tackles the following issues: a) How many Austrian German entries do German textbooks used in the secondary education in the Republic of Macedonia contain?; b) How many Swiss German entries do German textbooks used in the secondary education in the Republic of Macedonia contain?; and c) To what extent have the students in the final year of their secondary education mastered Austrian German and Swiss German? In order to ascertain the number of Austrian German and Swiss German entries used in the German textbooks we carried out an analysis which encompasses German textbooks endorsed by the Bureau of Pedagogy of the Republic of Macedonia at the Ministry of Education and Science of the Republic of Macedonia. According to the Common European Framework of Reference the analyzed German textbooks are compatible with B1 level. Additionally, taking into consideration the fact that the textbooks are not the only segment of the teaching process, and aiming to determine the extent to which the students in their final, forth, year of secondary education have mastered Austrian German and Swiss German and how they have mastered them, a survey was carried

out. The results indicate that there is inadequate application of the DACHL Concept and the pluricentricity of the German language, which, consequently, implies the necessity of utilizing additional language teaching materials which would alleviate not only the mastering of the German language but also the process of adaptation of students and adult learners of German in the German speaking countries. This would also prevent the occurrence of cultural and linguistic shocks, as well as the emergence of empathy towards the German language and culture.

**Index Terms-** language community, nation, the German language as an official language, dialect regions, pluricentricity of the German language, national variant, Austrian German and Swiss German

## I. INTRODUCTION

The German language is used in many countries such as, for instance, Liechtenstein, Luxembourg, South Tyrol, Eastern Belgium etc. However, this paper takes into consideration the German language used only in Germany, Austria and Switzerland. This restriction is made on the basis of the fact that the standard German language is characterized by certain differences in these three countries. In the standard German language used in Germany the equivalent term for the term dinner is "Abendessen", in Austria - the term "Nacht Mahl", in Switzerland the term - "Nachtessen".

Since ancient times there have been discussions on the meaning of the term "nation" as well as its connection with the term 'linguistic community'<sup>17</sup>. During the French Revolution both terms "nation" and "state" were associated with the term "national state" and this interpretation has been applied to date. The main idea was for states and nations to congregate within their own borders<sup>18</sup>. A linguistic community includes all people who speak the same native language, consequently, thus, all native speakers of the German language belong to the same linguistic community. According to Ammon, unlike the term 'nation' (linguistic nation or cultural nation), the terms 'linguistic community' and 'cultural community' do not suggest political association. Therefore, the people from the German-speaking part of Switzerland belong to the same linguistic community with people from Germany, but not to the same nation, i.e. the same linguistic and cultural nation. The people from the German-speaking part of Switzerland belong much more to the same nation as the people from the French-speaking, Italian-speaking, Romansh-speaking parts of Switzerland. Austria also does not

<sup>17</sup> (H. Haarmann, 1993:12)

<sup>18</sup> (U. Ammon, 1995:19)



belong to the German nation, at least not recently, as it has been establishing itself as a new nation<sup>19</sup>.

What is important for this paper is the definition of the German language as an official state language. According to Ammon's<sup>20</sup> there are seven countries where German is the official language. However, in only three of these countries, Germany, Austria and Liechtenstein, German is the only official language on a national level, i.e. in parliament, government, administration and so on. In the rest of the countries German is a co-official language, i.e. it is used as an official language alongside with other official languages. For instance, this is the case with Switzerland (official languages: German, French and Italian, and Romansh which is a regional official language) and in Luxembourg (official languages: German, French and Luxembourgish).

German as a regional official language is used in the German-speaking community in Belgium alongside with the French language, and the autonomous province of Bozen-South Tyrol in Italy alongside with Italian and Ladinian (in some areas). The most important regional dialects and national varieties of German, according to Ammon, are Niederdeutsch-Low German in north Germany, Mitteldeutsch-Middle German in central Germany, Oberdeutsch-Upper German in central and western Germany, Bairisch-Bavarian in southern Germany and Austria, Alemannisch in western Germany, Liechtenstein and Switzerland. Kretschmer has done significant research on the standard spoken language on the basis of which he concluded that the written forms which are avoided orally do not belong to the spoken language<sup>21</sup>.

There is one example provided by Kretschmer which deserves attention in this context, as it illustrates the differences between "the literary vernacular," and the "common language of the educated" in Berlin and Vienna, the capitals of the two major German-speaking countries.

*"A resident of Berlin enters a hat shop in Vienna and requests a Reisemütze. The seller corrects him: "Ah, you're looking for Reisekappe travel hat ". He places it on the table. The Berliner notes "I don't like the colorful ones". The seller interprets this to his German assistant "He is not fond of the colorful ones" because the Viennese like only people, not objects. The Berliner finally asks: "How expensive is the hat?" and again unintentionally makes a mistake because of the rude Berlinian expression 'expensive' which means a price that is above the normal rate, i.e. excessive price. The Viennese says only: "How much does it cost?" The Berliner seeks the cashier die Kasse, but only finds the sign Kassa. He leaves the store, and because it is early in the morning, he uses the greeting: "Good morning!" which instigates the Viennese to raise eyebrows as such a greeting is used only on arrival and not on departure. The Viennese response is: "It was my honor! Good day!" which, in turn, takes the Berliner by surprise, because the greeting: "Good day!" as far as he knows is used only on arrival and not on departure."*

<sup>19</sup> (U. Ammon, 1995:33)

<sup>20</sup> (U. Ammon, 1995:12)

<sup>21</sup> (P. Kretschmer, 1918:17)

Evidently, the German language has many linguistic centers, namely Germany, Austria and the German-speaking part of Switzerland, and is, therefore, a pluricentric language.

It is not easy to establish whether countries such as Liechtenstein, Luxembourg and parts of some countries such as South Tyrol in Italy, the German-speaking community in Belgium, where the German language is the official language have a special variant of the standard German language<sup>22</sup>. Languages are pluricentric if they are the official and administrative language of several major countries. Kloss mentions "the German language in the West Germany, East Germany, Switzerland, Austria" (without reflecting on the difference between the state and the nation)<sup>23</sup> as an example of such a pluricentric literary language. Reiffenstein agrees with Kloss about his description of the German language as a pluricentric language, but disputes the existence of different national varieties. This could be allowed only if "a coherent system of norms is codified for certain varieties"<sup>24</sup>. Contrarily, Clyne states that "German (...) is an instance of what Kloss terms a *pluricentric* language, i.e. a language with several national varieties, each with its own norms"<sup>25</sup>. A national variety cannot be recognized only as non-standard, it must be distinguished from the other national varieties of the same language, which are also standard. According to Ammon there is a vertical separation of the standard from the non-standard (in a social and stylistic sense) and a horizontal separation (non-standard in terms of regional restrictions)<sup>26</sup>.

Duden<sup>27</sup> considers Austriacisms as Austrian linguistic variants (e.g. Paradeiser for tomato). Stedje<sup>28</sup> points out some of the peculiarities of the German language in Austria represented by certain expressions (A / G) for example Obers / Sahne; Jause / Zwischenmahlzeit; Sessel / Stuhl; Fauteuil / Sessel; Trafik / Tabakladen; Jänner / Januar etc. Stedje mentions the impact of media and tourism. She also mentions the existence of expressions limited only to Bavaria and Austria, for example, *Grüß Gott* for *Guten Tag*, Topfen for Quark. She also notes the frequent use of diminutives from the Austrian-Bavarian dialect Stamperl / kleines Schnapsglas, Kasperl / Kasper, Backendl / Backhähnchen etc. which have spread even to northern Germany. Helvetisms are Swiss language features<sup>29</sup>. In German-speaking Switzerland the Schwyzerdütsch dialect functions as a spoken language understandable to all social strata<sup>30</sup>. The standard German language is largely a written language (called Swiss German) and is spoken only-but not always-in schools and churches, on television and radio, in court and classes.

All these differences clearly point to the need for acquiring Austriacisms and Helvetisms as significant features of the German-speaking countries.

<sup>22</sup> (U. Ammon, 1995:13)

<sup>23</sup> (H. Kloss, 1978:67)

<sup>24</sup> (I. Reiffenstein, 1983:23)

<sup>25</sup> (M. Clyne, 1984:1)

<sup>26</sup> (U. Ammon, 1995:89)

<sup>27</sup> Deutsches Universal Wörterbuch A-Z, 3, neu bearbeitete Auflage S. 195

<sup>28</sup> (A. Stedje, 2007:241)

<sup>29</sup> Deutsches Universal Wörterbuch A-Z, 3, neu bearbeitete Auflage S. 686

<sup>30</sup> (A. Stedje, 2007:243)

## II. THE LAYOUT OF THE RESEARCH

In the Republic of Macedonia, pursuant to a decision of the Ministry of Education of the Republic of Macedonia, the following three books have been approved for teaching German on high school level (level B1 according to the European Framework of Reference):

a) *Ausblick* - Hueber Verlag (decision number: 22-3635/1, dated from 1<sup>st</sup> June, 2010) - intended for teaching German as a second foreign language to forth-year high school students,

b) *Delfin* - Hueber Verlag (decision number: 11-6261/1, dated from 3<sup>th</sup> November, 2004) - intended for teaching German as a third foreign language to forth-year high school students,

c) *Ping Pong 3* - Hueber Verlag (decision number 22-3652/1, dated from 1<sup>st</sup> June, 2010) - intended for teaching German as a second foreign language to second and third year high school students.

The textbook *Ausblick* is intended for young people who are at B1 level or had already passed A2 level according to the European Framework of Reference. This textbook contains topics which are relevant for and of interest to young people. The program contains a textbook with two CDs; a workbook with a CD and online teachers' book posted on Hueber publishing house's website.

The textbook *Delfin* offers a one-volume, two-volume and three-volume edition, which contain 20 lessons in total. The program has a clear structure with five double pages for each lesson: *introduction-reading-listening-speaking-writing*. The transparency of the textbook enables clear distribution of the material. The workbook can be used for doing intensive exercises during class hours and/or flexible individual studying at home. Moreover, Hueber publishing house's website<sup>31</sup> offers additional online activities.

The textbook *Ping Pong 3* enables students, by means of fun activities and games, to systematically target and reach the level required for obtaining a Certificate of German as a foreign language.

The workbook offers extensive exercises which accompany each and every lesson in the textbook. These exercises are suitable for developing all the necessary skills, however, a special accent is put on developing students' reading comprehension skills. Additionally, not only are the topics of the exercises compatible with the topics discussed in the textbook, but also they are very useful for developing students' global, detailed and selective reading skills which are necessary for obtaining a Certificate of the German.

The Bureau of Education Development of the Republic of Macedonia as an institution authorized by the Ministry of Education and Science of the Republic of Macedonia is responsible for preparing the syllabi for all the respective courses at all educational levels.

What is relevant for our research is the syllabi of two German courses within the framework of the reformed high school education intended for the fourth year students, namely German as a second foreign language and German as a third

foreign language. The syllabi for these two courses were adopted in 2003 and published on the Ministry of Education and Science's website<sup>32</sup>. They contain a list of the most important information that the teachers of German should know about German as a second foreign language course (with projected 2 class hours per week, or a total of 72 hours per school year); and German as a third foreign language course (with projected 3 class hours per week or a total of 99 hours per school year).

The syllabi outline the objectives, skills and contents of the courses in a clearly structured manner. There are two types of course objectives: general and specific. The general objectives, inter alia, include the fact that "the students who have successfully completed these courses will be able to use the German language in everyday life situations"<sup>33</sup>. The specific objectives, inter alia, include that "the students will gain a certain amount of sociolinguistic knowledge which will help him overcome various communicative problems and familiarize themselves with the cultural characteristics of the Federal Republic of Germany as well as the other German-speaking countries, which, eventually will facilitate the creation of intercultural exchange and tolerance as a critical application of knowledge".

Taking all these objectives into consideration, it becomes evident that both the process of teaching German and the German textbooks should contain vocabulary typical of the other German speaking countries such as, for instance, Austriacisms and Helvetisms.

## III. THE RESULTS OF THE ANALYSIS

The textbook *Ausblick* includes the following terms associated with Austria and Switzerland: Austria on page 52; Austria and Switzerland on page 99; Switzerland and information regarding the Swiss writer Peter Bichsel on page 102; the map of Switzerland on page 106 and page 107; Austria on page 108; Switzerland page 108; Swiss on page 108; Austria, Switzerland, Liechtenstein, cities in Switzerland and Austria on page 109. In the workbook the following terms were detected: Austria on page 7, Austria on page 107; Austria and Switzerland on page 148.

These findings suggest that only names of geographic places in Austria and Switzerland have been mentioned in this book.

From a linguistic point of view, certain Austriacisms and Helvetisms were detected in: the audio exercises in Lesson 10 on page 106, where an Austrian-Bavarian greeting, "Servus Österreich", the Swiss term "Velo" for bike, and the Swiss greeting "Grüezi" have been mentioned but only in oral form as there is no written record of these terms in the textbook or the workbook.

In the textbook *Delfin* the terms Austria, Switzerland, some cities in these countries, celebrities and the education system have been mentioned in almost all the lessons. The workbook, on

<sup>32</sup>

<http://bro.gov.mk/docs/gimnazisko/zadolzitelniPredmeti/GermanskijazikIVg.vtorstranskijazik.pdf>

<sup>33</sup>

<http://bro.gov.mk/docs/gimnazisko/zadolzitelniPredmeti/GermanskijazikIVg.vtorstranskijazik.pdf>

<sup>31</sup> <http://www.hueber.de/ausblick>

the other hand, contains Austriacisms and Helvetisms which are presented in the table below. Namely, the table lists the number of the page where each of these terms has been found as well as their German equivalents.

Seite	In Deutschland sagt man	In Österreich sagt man	in der Schweiz sagt man
41	die Kartoffel, Kartoffeln	der Erdapfel, Erdäpfel	
41	die Tomate, Tomaten	der Paradeiser, Paradeiser	
41	der Pilz, Pilze	das Schwammerl, Schwammerln	
41	die E-Mail, E-Mails		das E-Mail, E-Mails
41	Prost!		Gesundheit!
60	der Junge, -n	der Bub, -n	
60	der Schreibtisch, -e		das Pult, -e
60	der Stuhl, -e	der Sessel, -	
60	die Telefonkarte, -n	die Telefonwertkarte, -n	die Taxcard
78	ausmachen	abdrehen	
78	abschließen	absperren	
78	zumachen	zusperrern	
78	die Anzeige, -n		die Annonce, -n
78	die Kleidung (Sg.)		die Kleider (Pl.)
78	das Fahrrad, -er		das Velo, -s
78	bunt		farbig
78	prima	super	
99	die Arztpraxis, Arztpraxen	die Ordination, -en	
99	der Briefträger, -		der Pöstler, -
99	der Fahrer, -		der Chauffeur, -e
99	die Haltestelle, -n	die Station, -en	die Station, -en
99	das Krankenhaus, -er	das Spital, -er	das Spital, -er
99	die Telefonzelle, -n		die Telefonkabine, -en
99	klingeln	läuten	läuten
99	laufen	rennen	
125	das Brötchen	die Semmel	
125	das Frühstück		das Morgenessen
125	der Reifen		der Pneu
125	Ich habe gerade die Betten gemacht.	Ich habe eben die Betten gemacht.	
145	der Bürgermeister, -	der Bürgermeister, -	der Stadtpräsident, -en/ der Amman, -er
145	der Führerschein, -e	der Führerschein, -e	der Führerausweis, -e
145	der Glückwunsch, -er	der Glückwunsch, -er	die Gratulation, -en
168	die Bohne, -n	die Fiole, -n	
168	die Cola	das Cola	das Cola
168	das Brötchen, -	die Semmel, -n	
168	die Dose, -n	die Büchse, -n	
168	das Eis		die Glace
168	das Gericht, -e	die Speise, -n	
168	der Joghurt	das Joghurt (auch: die Joghurt)	das Joghurt
168	die Kartoffel, -n	der Erdapfel, -	
168	die Kasse, -n	die Kassa, Kassen	
168	die Marmelade, -n		die Konfitüre, -n
168	das Päckchen, -	das Packerl, -n	
168	der Pilz	das Schwammerl, -n	
168	die Sahne	der Schlag, das Schlagobers	der Rahm
168	die Tüte, -n	das Sackerl, -n	
193	an sein	brennen	
193	ansehen	anschauen	
193	die Couch, -en	das Sofa, -s	das Sofa, -s

193	der Kasten, -"	die Kiste, -n	
193	der Prospekt, -e	das Prospekt, -e	
193	der Schrank, -"e	der Kasten, -"	der Kasten, -"
193	der Sessel, -		der Fauteuil, -s
193	der Stuhl, -"e	der Sessel, -	
219	aussehen	ausschauen	
219	bunt		farbig
219	der Friseur, -e		der Coiffeur, -e
219	die Kleidung		Kleider (Pl.)
219	der Rock, -"er		das Kleid, -er
245	das Abitur	die Matura	die Matura
245	das Gehalt, -"er	der Lohn, -"er	der Lohn, -"er
245	die Praxis, Praxen	die Ordination, -en	
245	inzwischen		unterdessen
275	die Kneipe, -n	das Beisl, -n/s	Gasthaus, -"er
275	die Metzgerei, -en	die Fleischhauerei, -en	
303	Auf Wiedersehen/Tschüs	Servus	Uf Wiederluege
334	der Mülleimer, -	der Mistkübel, -	
334	die Jugendlichen (Pl.)		die Jungen (Pl.)
364	die Krankenkasse	die Krankenkassa	
364	genau		exakt
397	das Erdgeschoss, -e	das Parterre	das Parterre
397	die Werbung, -en		die Reklame, -n
397	die Gebrauchsanweisung, -en		die Gebrauchsanleitung, -en
421	die Eintrittskarte, -n		das Billet, -s
421	die Illustrierte, -n		das Heft, -e
421	treten	steigen	
474	das Kissen, -	der Polster, -	
474	der Bahnsteig, -e		der/das Perron, -s
474	erscheinen		herauskommen
474	blass		bleich
503	anfassen	angreifen	
503	umziehen	übersiedeln	
503	die Klingel, -n	die Glocke, -n	
503	der Pfannkuchen, -	die Palatschinke, -n	
503	beeilen		pressieren
503	Prost!		Gesundheit!

**Table 1**

On the basis of this analysis it could be concluded that the authors of the textbook Delfin, Hartmut Aufderstrasse, Uta Müller and Thomas Storz, have adequately observed and implemented the DACHL concept. They supported this by claiming that "although most of the German terms listed in the table above could be understood in Switzerland and Austria, yet it could be quite helpful if students know their Swiss and Austrian equivalents as well"<sup>34</sup>.

The survey was conducted among randomly selected 45 fourth-year high school students from the town of Bitola. The majority of the students were female and they have been studying German for 7 or 8 years. Thirty five of the students were studying German as a second language, whereas only nine of them were studying German as a third language.

All of the respondents knew the fact that German is spoken in Germany, Austria and Switzerland.

However, an interesting fact is that 29 students cited the expression *Griß Gott* and *Semmel* as specific Austrian terms, while 14 students were not aware of the Austricisms. One student identified the term *Velo* as a Swiss term, which is true, but another student thought that the term *Sackerl* is a Helvetism – when, in fact, is an Austricism. The students successfully recognize the German greeting terms, which is not surprising given the fact that all textbooks contain the most prevalent forms of greetings used in Germany. Eleven students have partially recognized the forms of greetings used in Austria (*Griß Gott*, *Servus*). They are not familiar at all with the forms of greeting used in Switzerland, obviously, due to their omission from the textbooks. Twenty five students are familiar with *Die Semmel* and that it was used for *bun* in Austria. The others thought that it

<sup>34</sup> Delfin, Huber Verlag. Lehrerhandbuch S.28

is used in Switzerland or Germany, or they did not know anything about it. Sixteen students were familiar with *Der Erdapfel*, i.e. with the fact that it was used for *potato* in Austria. The others thought that it was used in Switzerland or Germany or they knew nothing about it. Fifteen students were familiar with *Der Paradeiser* and the fact that it is used for *tomato* in Austria. The others thought that it was used in Switzerland or Germany or did not know anything about it. Twelve students were familiar with *Das Velo* and that it was used for *bike* in Switzerland. The others thought it was used in Austria or Germany or they did not know anything about it. Eight students were familiar with *Das Sackerl* and that it was used for *bag* in Austria. The others thought it was used in Switzerland or Germany or they did not know anything about it. Eight students were familiar with *Das Bussel* and that it was used for *kiss* in Austria, seven students knew that it was used in Germany, and others thought it was used in Switzerland or they did not know anything about it.

#### IV. CONCLUSION

In conclusion, the Austriacisms and Helvetisms are not adequately represented in the analyzed German textbooks (level B1) used in high school education in the Republic of Macedonia or in teaching German in general. An exception to this is the textbook *Delfin* which is used in teaching German as a third foreign language. These results indicate that the students who study German as a second foreign language are less exposed to Austriacisms and Helvetisms, in comparison to those who learn German as a third language. However, the number of the latter group is significantly lower than the number of the former group. In summary, knowing the varieties of the German language allows students to improve their communication with people from the German-speaking countries whereas ignoring them could result in very uncomfortable situations. Hence, it is highly recommended that both textbooks' authors and teachers of German should incorporate Austriacisms and Helvetisms in their books and teaching, respectively. The starting point, understandably, could be some specific forms of greetings used in Austria and the specific Austrian terms used in general everyday communication.

#### REFERENCES

- [1] Ammon, U. (1995): Die deutsche Sprache in Deutschland, Österreich und der Schweiz. Walter de Gruyter & Co. Berlin-New York
- [2] Aufderstraße, H./ Müller, H./ Storz, T.(2003) Delfin, Huber Verlag. Lehrerhandbuch
- [3] Clyne, M. (1984): Language and Society in the German-Speaking Countries. Cambridge: Cambridge University Press
- [4] Haarmann, H. (1993): Die Sprachenwelt Europas. Geschichte und Zukunft der Sprachennationen zwischen Atlantik und Ural. Frankfurt/New York: Campus
- [5] Kloss, H. (1978): Die Entwicklung neuer germanischer Kultursprachen seit 1800. 2 erw. Aufl. Düsseldorf: Schwann
- [6] Kretschmer, P. (1918): Wortgeographie der hochdeutschen Umgangssprache 2. erg. Aufl. Göttingen: Vandenhoeck & Ruprecht
- [7] Reiffenstein, I. (1983): Deutsch in Österreich In Reiffenstein, I. u.a. (eds.) Tendenzen, Formen und Strukturen der deutschen Standardsprache nach 1945. Marburg: Elwert
- [8] Stedje, A. (2007): Deutsche Sprache gestern und heute 6.Auflage Wilhelm Fink Verlag

- [9] Deutsches Universal Wörterbuch A-Z, 3.,neu bearbeitete Auflage
- [10] <http://www.hueber.de/ausblick>
- [11] [http://www.hueber.de/seite/info\\_del](http://www.hueber.de/seite/info_del)
- [12] [http://www.hueber.de/seite/info\\_kb3\\_ping?menu=10455](http://www.hueber.de/seite/info_kb3_ping?menu=10455)
- [13] <http://bro.gov.mk/docs/gimnazisko/zadolzitelnipredmeti/GermanskijazikIVg.vtorstranskijazik.pdf>
- [14] <http://bro.gov.mk/docs/gimnazisko/zadolzitelnipredmeti/GermanskijazikIVg.vtorstranskijazik.pdf>
- [15] <http://bro.gov.mk/docs/gimnazisko/zadolzitelnipredmeti/GermanskijazikIVg.vtorstranskijazik.pdf>
- [16] <http://bro.gov.mk/docs/gimnazisko/zadolzitelnipredmeti/GermanskijazikIVg.vtorstranskijazik.pdf>

#### AUTHORS

**First Author** – Valentina Ilieva PhD, Faculty of Education, Bitola, Macedonia, [kommtina@yahoo.de](mailto:kommtina@yahoo.de)



# Read/Write Stability Improvement of 8T Sram Cell Using Schmitt Trigger

Dr. A. Senthil Kumar<sup>\*</sup>, I.Manju<sup>\*\*</sup>, S.Sumathi<sup>\*\*</sup>, C.Preethi<sup>\*\*\*</sup>

<sup>\*</sup> Professor, Electrical and Electronics Engineering, Velammal Engineering College

<sup>\*\*</sup> Assistant Professor, Electronics and Communication Engineering, Velammal Engineering College

<sup>\*\*\*</sup> Student, Electronics and Communication Engineering, Velammal Engineering College

**Abstract-** In recent years the demand for low power devices has increased tremendously due to the migration of computer workstations to handheld devices that need real-time performance within the budget for physical size and energy dissipation. As a result of this there is a fast growth of battery operated portable applications such as PDAs, cell phones, laptops and other handheld devices. But also at the same time problems arising from continuous technology scaling have recently made power reduction an important design issue for the digital circuits and applications. Operating at low power causes SRAM read-stability and write-ability as major design constraints. The stability of read and write operations can be increased using Schmitt trigger based SRAM bit cells. In this paper the Schmitt trigger design is implemented in 8 transistor SRAM cell to increase read-stability and write-ability than the conventional 6T cell. The design is implemented in Tanner EDA tool and the results are observed.

**Index Terms-** low power usage, 6T cell, stability.

## I. INTRODUCTION

The growing market of portable battery-operated systems demands micro-electronic circuit design with ultra low power dissipation. This emerging portable SoC designs demand for low power SRAMs. The overall power dissipation can be achieved through the scaling down of supply voltage [1]. But reducing the supply voltage limits the circuit to operate in low power due to effect of process variations. It is forecasted that embedded memory in SOC designs will cover up to 90% of the total chip area. To achieve longer battery life in portable devices low-power SRAM array is necessary. Due to technology scaling, the number of transistors on a die is increased causing an increase in density. This has an exponential impact on leakage power. The Schmitt trigger design reduces the leakage current thereby reducing power consumption.

In section II, the conventional 6T SRAM design is discussed, its operation and drawbacks. In section III, available 6T ST design is discussed. In section IV the proposed 8T design is discussed. In section V the design and output waveform for the existing 6T cell and the proposed design are given.

## II. PRELIMINARY STUDIES

Depending upon various design goals such as bit density, bitcell area, low voltage operation several SRAM cells have been

proposed. A 6T bit cell is the most commonly used memory bitcell in the present designs[1]. Full Transmission gates are used in a Single-ended 6T bit cell[9]. In this design write ability is achieved by modulating the virtual-vcc and virtual vss. Single ended 7T bit cell[2] consists of a single ended write operation and a separate read port. S. Birla et al in their work[11], found that as voltage decreases the SNM decreases in a 8T cell which along with a leakage reduction mechanism will provide a better stability.

A low power read stable single-ended 8T cell designed[12] and it is shown that it consumes less power than the conventional 6T cell. It is shown in [13],[14] that stacking of transistors will reduce the leakage. A differential 10T bit cell with two separate ports are also reported.

From the study, it is clear that the basic element for storage is a cross-coupled inverter pair. For a successful operation of SRAM cell with better read and write stability a new design approach is required. Hence, Schmitt trigger based design is implemented in 8T cell to achieve the above mentioned stability.

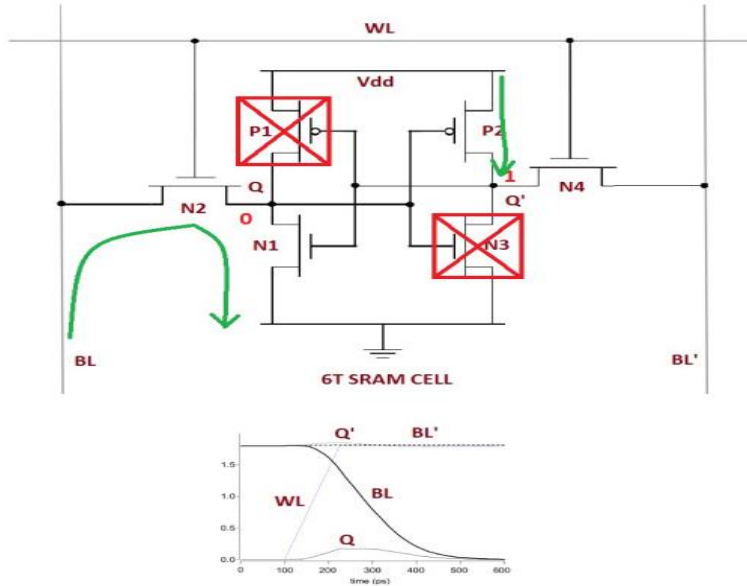
## III. AVAILABLE 6T CELL AND ITS DRAWBACK

The mainstream six-transistor (6T) CMOS SRAM cell is shown in the figure. The SRAM cell constituted of a flip-flop. The logical values '0' or '1' get stored at the storage nodes[8]. This 6T cell consists of two inverters: Load MOSFET and Driver MOSFET and two access MOSFETs that are connected to bit lines (BL & BL'). The access transistors are also connected to a word line (WL). To form a flip-flop, the input and output of one inverter is connected to the output and input of another inverter, respectively. This forms a cross-coupled pair of inverters.

### Read operation

Bit lines are precharged to supply voltage before read operation. The read operation is initiated by enabling the word line (WL) and thereby connecting the internal nodes of the SRAM bitcell to bit-lines. The bit line voltage is pulled down by the NMOS transistor at the '0' storage node and the difference between two bit line voltages will be detected by sense amplifier. When the word line (WL) is high, one of the bit line voltages is pulled down through transistors M2 and M6 or M1 and M4. The transistors M2 and M6 forms a voltage divider, because of current flowing through M2, the potential at node is no longer at '0'v. Also it should not go beyond switching threshold inverter (INV1) to avoid destructive read. The rising of potential depends on sizing of access transistor and pull down transistor which is

defined as a bit cell ratio. The read operation is explained with a diagram which is given below,

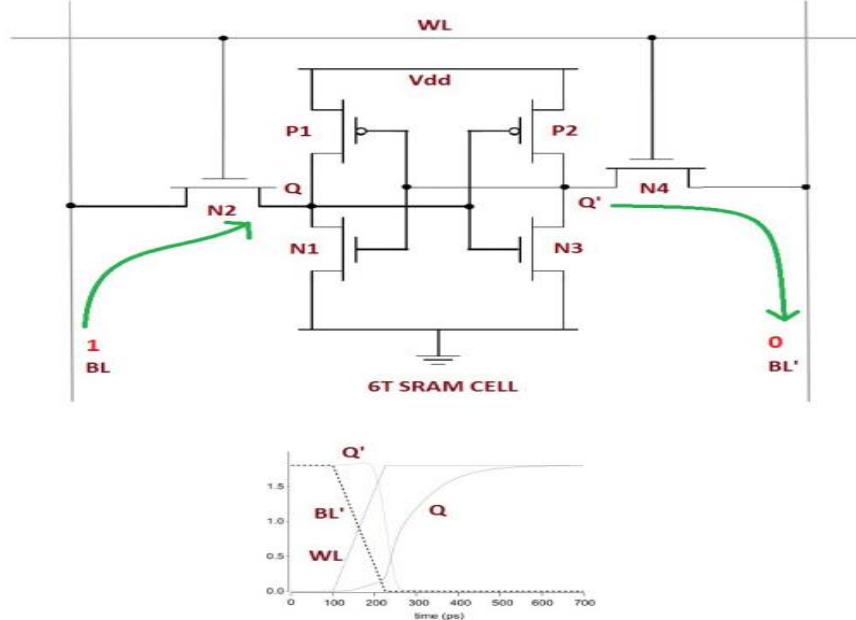


**Figure 1 Read Operation of 6T cell**

*Write operation*

During write operation, the pre-charged logic is kept at low. Suppose to store logic '1'. Bit line is charged to and bit bar line is discharged to ground. When the word line is activated, the data

on bit and bit bar lines are written into the output nodes of the cell. During updating of content, one should remember that the voltage where logic '1' is stored must be less than the threshold voltage of the driver transistor of other inverter.



**Figure 2 Write operation of conventional 6T cell**

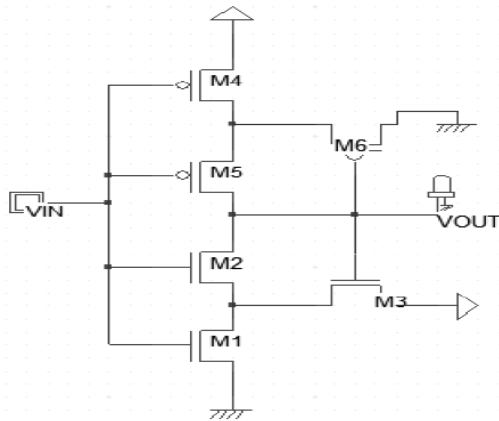
*Drawback of 6T SRAM cell*

The conventional 6T cell schematic shown in the above figure is the most commonly used SRAM implementation and it has the advantage of very less area. However, the potential stability problems of this design arises during read and write operation, where the cell is most vulnerable towards noise and thus the stability of the cell is affected. If the cell structure is not designed properly, it may change its state during read and write operation.

**IV. EXISTING SCHMITT TRIGGER BASED SRAM CELL**

At very low voltages, the cross coupled inverter pair stability is of concern. To improve the inverter characteristics, Schmitt configuration is used. A Schmitt Trigger increases or decreases the switching threshold of an inverter depending on the direction of the input transition. The cross-coupled inverter pair of an SRAM cell operating at low supply voltages consumes high

power. So to improve the inverter characteristics, Schmitt trigger configuration is used.



**Figure 3 Schmitt Trigger configuration**

To resolve the conflict present between the read and write design requirements in the conventional 6T bit cell, we need to apply Schmitt Trigger(ST) principle for the cross-coupled inverter pair. The feedback mechanism is used in the pull-down path in this STSRAM bit cells. By raising the source voltage of pull-down NMOS (N1), the feedback transistor tries to preserve the logic '1' while the input transition is made as 0. This results in higher switching threshold of the inverter with very sharp transfer characteristics. Since read-failure is initiated by a 0 input transition for the inverter storing logic '1', higher switching threshold with sharp transfer characteristics of the Schmitt trigger gives robust read operation. During the transition the feedback mechanism is not present.

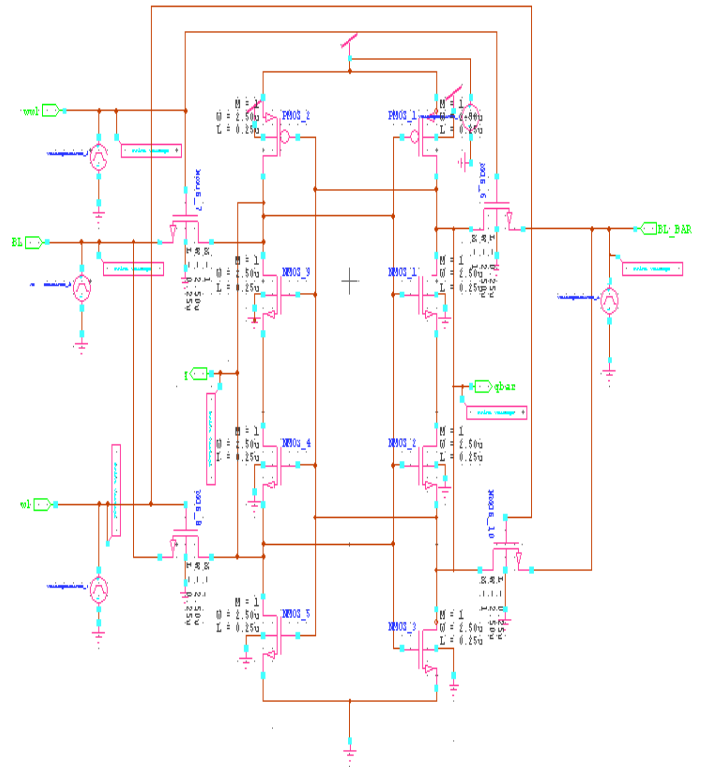
This results in smooth transfer characteristics that are essential for easy write operation. Thus input dependent transfer characteristics of the Schmitt trigger improves both read stability as well as write-ability of the SRAM bit cell.

The above achieved stability can further be increased by introducing read/write assist techniques along with the Schmitt trigger design. By introducing more transistors the read and write operation can be designed not to affect the stored value.

### V. PROPOSED 8T SCHMITT TRIGGER CELL

In a eight-transistor (8T) CMOS SRAM cell, extra transistors are added to the conventional 6T cell, so that the read and write operation are separated. This topology was originally

proposed for a sub-threshold SRAM design. It is optimized to operate at low power. The proposed design is given below in the figure.



**Figure 4 Proposed 8T ST SRAM cell**

### VI. RESULTS AND DISCUSSIONS

This section provides the simulation result for the newly designed 8T SRAM. The design is implemented in Tanner EDA tool. The waveform representing various voltage levels for the existing 6T ST and 8T ST are given here. From the waveform it can be inferred that in the 8T ST structure, the stored value is preserved during read operation.

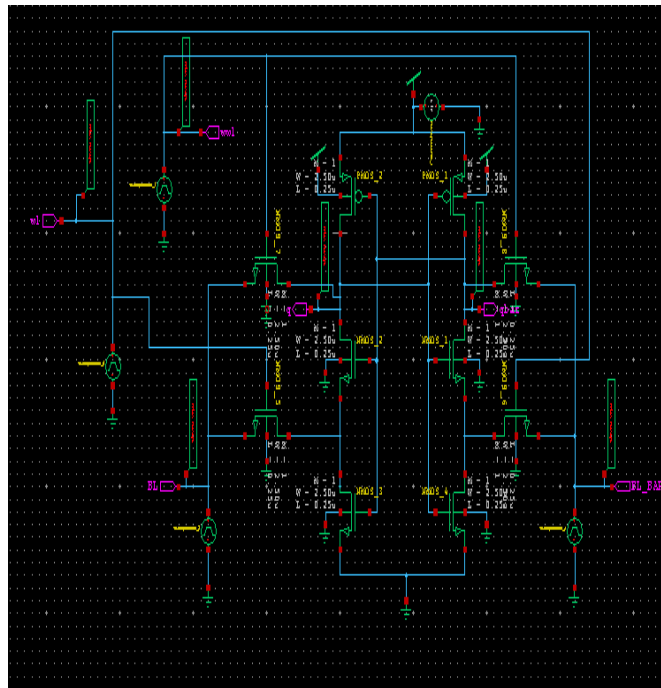


Figure 5 Schematic of 6T ST in Tanner Tool

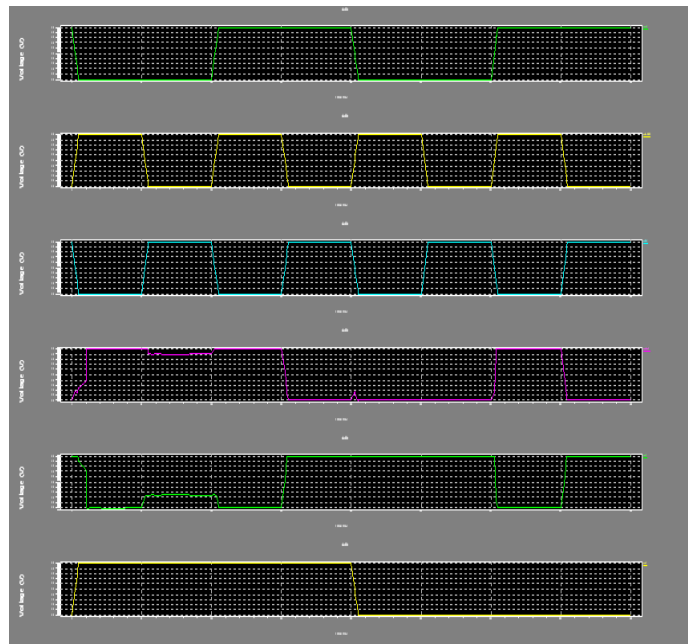


Figure 6. Waveform of operation of 6T ST in Tanner

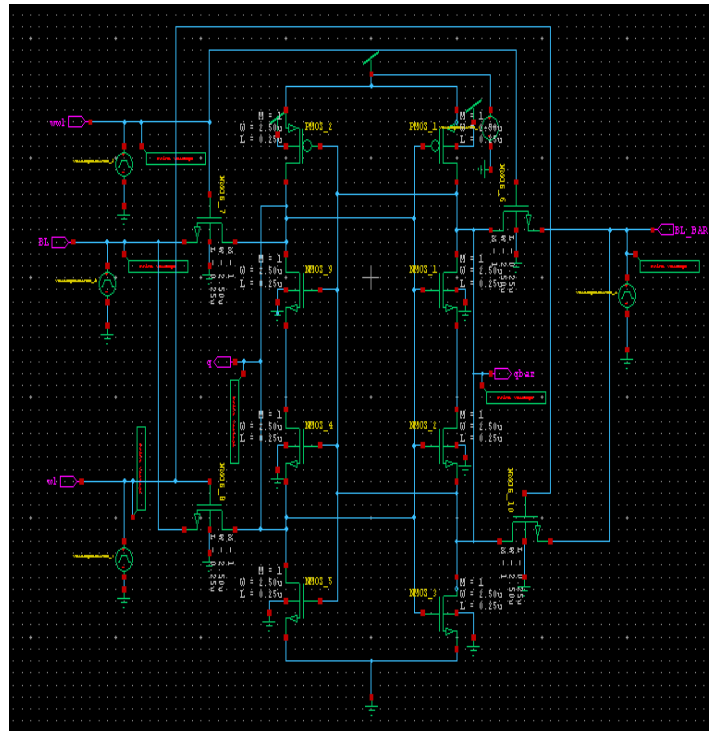


Figure 7. Schematic of 8T ST SRAM cell in Tanner Tool

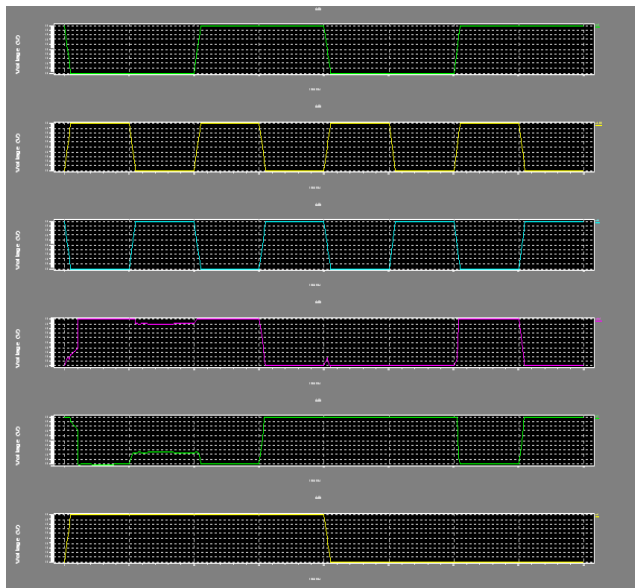


Figure 9 Waveform for the operation of 8T ST cell in tanner

## VII. CONCLUSION

Supply voltage reduction is the effective way for ultra low power operation. Thus in this paper, a stable SRAM cell design is implemented through the use of Schmitt trigger based SRAM design in the eight transistor cell.

## REFERENCES

- [1] Jaydeep .P. kulkarni, Kaushik Roy, "Ultra low voltage process variation tolerant Schmitt trigger based design", IEEE transactions on very large scale integration, vol. 20, February 2012.
- [2] T. Suzuki, H. Yamauchi, Y. Yamagami, K. Satomi, and H. Akamatsu, "A stable 2-port SRAM cell design against simultaneously read/write disturbed access", IEEE J.Solid state circuits,vol 43,no. 9,Sep 2008.
- [3] M. Grossar, M. Stucchi, K. Maex and W. Dehaene, "Read Stability and Write ability analysis of SRAM cells for Nanometer technologies", IEEE J. Solid State Circuits, vol.1,no.11,Nov 2006.



- [4] Z. Liu and V. Kursun, "High read stability and low leakage cache memory cell," IEEE Trans. Very Large Scale Integr (VLSI) syst., vol.16, no.4, Apr 2008.
- [5] A. Bhavnagarwala, X. Tang and J. Meindl, "The impact of intrinsic device fluctuations on CMOS SRAM cell stability", IEEE J. Solid State Circuits, Vol.36, no.4, Apr 2001.
- [6] K. Roy and S. Prasad, "Low Power CMOS VLSI Circuit Design, 1st ed. New York: Wiley 2000.
- [7] J. P. Kulkarni, K. Kim and K. Roy, "A 160 mV robust Schmitt trigger based subthreshold SRAM," IEEE J. Solid-State Circuits, vol.42, no.10, Oct. 2007.
- [8] Koichiro Ishibashi, Kenichi Osada, "Low power and reliable SRAM memory array," Springer.
- [9] B. Zhai, D. Blaauw, D. Sylvester, and S. Hanson, "A sub-200mV 6T SRAM in 0.13 $\mu$ m CMOS," in proc. Solid State circuits conf, Feb 2007.
- [10] H. Mahmoodi, S. Mukhopadhyay and K. Roy, "Modeling of failure probability and statistical design of SRAM array for yield enhancement in nanoscaled CMOS," IEEE Trans. Comput-Aided Design (CAD), Dec 2005.
- [11] S. Birla, Neeraj Kumar, Kapil, "Analysis of 8T SRAM cell at Various Process Corners at 65nm process technology," Scientific research, Circuits and systems, 2011.
- [12] Nahid Rahman, B. P. Singh, "Design of low power SRAM memory using 8T SRAM cell," International Journal of Recent Technology and Engineering, vol.2, March 2013.
- [13] S. Lin, Y.B. Kim and F. Lombardi, "A highly-stable nanometer memory for low-power design," in proc. IEEE Workshop design test of Nano devices, Circuits 2008
- [14] S. Verkila, S. Bondada, and B. Amrutur, "A 100MHz to 1 GHz, 0.35V to 1.5V supply 256 x 64 SRAM block using symmetrized 9T SRAM cell with controlled read," in proc. Int. Conf. VLSI Design, 2008

#### AUTHORS

**First Author** – Dr. A. Senthil Kumar, Professor, Electrical and Electronics Engineering, Velammal Engineering College, Chennai, India, vastham@gmail.com

**Second Author** – I. Manju, Assistant Professor, Electronics and Communication Engineering, Velammal Engineering College, Chennai, India, manjujackin@gmail.com

**Third Author** – S. Sumathi, Assistant Professor, Electronics and Communication Engineering, Velammal Engineering College, Chennai, India, sumathiapece@gmail.com

**Fourth Author** – C. Preethi, Student, Electronics and Communication Engineering, Velammal Engineering College, Chennai, India, preethan17@gmail.com

# Impact of balanced fertilization and legume mixture on fodder oat (*Avena sativa* L.)

Arjun Kumar Verma\* and K. L. Jeengar\*\*

\*SMS (Agronomy)

\*\*Programme Coordinator, Krishi Vigyan Kendra, Jhalawar-326 001, India, Maharana Pratap University of Agriculture and Technology, Udaipur (Rajasthan).

**Abstract-** A field experiment was conducted to study the effect of balanced fertilization and legume mixture on fodder oat productivity during *rabi* season at instructional farm, Rajasthan College of Agriculture, Udaipur (Rajasthan). Legume mixture oat + berseem (2:1 row ratio) and oat + lucerne (2:1 row ratio) significantly improved number of tillers/m<sup>2</sup>, green fodder, dry fodder yield and protein yield over sole oat. Similarly, application of 120 kg N+ 60 kg P<sub>2</sub>O<sub>5</sub> + 30 kg K<sub>2</sub>O/ ha significantly improved the highest number of tillers/m<sup>2</sup>, green fodder, dry fodder yields and protein yield over nitrogen application to the magnitude of 11.93 and 11.36; 31.91, 30.83 and 31.39, 8.88, 11.57 and 10.19 and 10.94 and 13.05 percent at first and second cutting, respectively.

**Index Terms-** Fodder oat, balanced fertilization, legume mixture

## I. INTRODUCTION

In most of the developing countries of the world, livestock is an integral part of the agricultural economy. Crop production system is closely linked with animal husbandry as a complementary enterprise. Crops are of prime importance for economic feeding of animal on one hand, and on the other hand, the livestock through the supply of organic manures and draft power helps in balancing crop growth. The importance is more emphasized in India, as it owns the largest livestock population in the world and accounts nearly 16 per cent of the world's cattle population. The contribution of livestock sector to agriculture GDP accounts for 25 per cent of agricultural output and now India has become the largest producer of milk in the world (Kadriev, 2002). In India, Rajasthan state has 54 million livestock population and the animal heads exceed human heads, which poses the problem of feed-fodder security for the state. Nearly 8 per cent of the milk and 40 per cent of wool production in the country is from Rajasthan state (FAO 1998). It has been experienced that even in the best agricultural years fodder supply through all the sources is short of aggregate fodder demand in the state.

In order to make animal husbandry sector more viable and productive sector there is a great need to maintain balanced feed and fodder supply in the state. The major dependence on agricultural by-product to feed the animal is detrimental to the growth of both livestock and crop sector in the state. Once the fodder supply is streamlined with more nutritious feed and fodder by stall-feeding, more productive milch herd can be sustained which in turn would accelerate the growth of milk

production in the state. At present time, requirements of fodder are not fulfilled. Majority of the animals are reared under sub-optimal conditions because of shrinkage in grazing land, poor management of wasteland and grazing pressure per unite land. Availability of nutritious feed and fodder through proper scientific methods, are essential for the improvement of the vast livestock resource. Therefore, there is a need to boost the production of green and dry fodder yield. Among the fodder crops, oat is important winter forages. It is highly nutritive forage, which is rich in soluble carbohydrates. Being more energizing, it forms a good feed for horses and draught as well as milch animals (Kumar and Rai, 1976). Puri *et al.* (2010) observed higher fodder yield of the ryegrass + oat/sarson over pure crop of ryegrass in the first cutting. Tiwana and Singh (2012) reported that cropping system of oat + sarson gave higher fodder yield when harvested at 65 days after sowing (DAS) as compare to 55 DAS. Kumar *et al.* (2010) reported 29.9 percent crude protein content in berseem + 1.88 kg sarson/ha as compared to 27.9 percent in pure berseem. The balanced nutrient supply ensures efficient use of all nutrients. One nutrient may affect the efficiency of other nutrients. Since, there is paucity of information of aforesaid aspect a field experiment entitled "Impact of balanced fertilization and legume mixture to fodder oat (*avena sativa* L.)" was planned.

## II. MATERIALS AND METHODS

The field experiment were conducted during *rabi* at Instructional farm, Department of agronomy, Rajasthan College of Agriculture, Udaipur. The soil of experimental fields was clay loam in texture, alkaline in reaction (pH 7.9 and 8.1), medium in available N, P and higher in potassium 287.00 and 283.00, 22.61 and 22.75 and 390.00 and 397.00 kg/ha and organic carbon 0.71 and 0.81%. The treatments consisting of seven legume mixtures viz., L<sub>0</sub>= sole oat; L<sub>1</sub> = oat + berseem (2:1 row ratio); L<sub>2</sub> = oat + berseem (3:1 row ratio); L<sub>3</sub> = oat + berseem (4:1 row ratio); L<sub>4</sub> = oat + lucerne (2:1 row ratio); L<sub>5</sub> = oat + lucerne (3:1 row ratio); and L<sub>6</sub> = oat + lucerne (4:1 row ratio) and three balanced fertilization viz., N (120 kg/ha); N+P (120 kg N+60 kg P<sub>2</sub>O<sub>5</sub>/ha) and N + P + K (120 kg N+ 60 kg P<sub>2</sub>O<sub>5</sub> + 30 kg K<sub>2</sub>O/ha) were tested in a split plot design having legume mixtures in main plots and balanced fertilization in sub plots and replicated thrice. Crop was sown on Nov. 22<sup>nd</sup> and 20<sup>th</sup> in first and second year, respectively. Crops were fertilized with nitrogen through urea, P<sub>2</sub>O<sub>5</sub> and K<sub>2</sub>O through DAP and MOP as per treatment. One third dose of nitrogen and full dose of phosphorus and potassium

were applied in basal application at sowing time and rest 1/3<sup>rd</sup> nitrogen at first irrigation and treatment 1/3<sup>rd</sup> dose after first cutting. First and second cutting of crop were harvested on January 21 and March 21 during first year and January 21 and March 21 during second year of experimentation, respectively.

### III. RESULTS AND DISCUSSION

#### **Legume mixture**

A critical examination of data (Table and Figure 1, 2 and 3) reveals that legume mixture had significant effect on number of tillers/m<sup>2</sup>, green fodder, dry fodder yield, protein content and protein yields over oat at first and second cutting in pooled analysis. The pooled data for the two years show that oat : berseem (2:1) recorded significantly higher number of tillers/m<sup>2</sup>, green fodder, dry fodder yield, protein content and protein yields amounting to increases of 16.71 and 20.35 and 22.76 and 22.99 and 22.87; 17.87, 21.00 and 19.38; 110.58 and 12.30; 29.95 and 35.60 percent, respectively over sole oat sown. Legume mixture oat + berseem (2:1) was closely followed by oat + lucerne (2:1) in pooled analysis and significantly improved the above said parameters over sole oat, respectively. The observed improvement in various characters might be owing to beneficial effect of legumes on cereal as legume fixes nitrogen in the soil through the process of biological nitrogen fixation, which is utilized by the oat and its role in tillering is well established. These findings was corroborating with the findings of Choubey and Prasad (2001).

#### **Balanced Fertilization**

It is evident from the data presented in Table and Figure 1, 2 and 3 reveals that balanced fertilization had significant effect on number of tillers/m<sup>2</sup>, green fodder, dry fodder yields, protein content and its production at both the cuttings in pooled analysis. Application of 100% NPK (120 kg N + 60 kg P<sub>2</sub>O<sub>5</sub> + kg K<sub>2</sub>O/ha) significantly recorded the highest number of tillers/m<sup>2</sup>, green fodder yield, dry fodder yield and protein yield over N alone and N+P both application in pooled analysis. The corresponding increases were to the magnitude of 11.90 and 11.36; 31.91, 30.83 and 31.39; 8.88, 11.57 and 10.19 and 10.94 and 13.05 percent in case of number of tillers/m<sup>2</sup>, green fodder yield, dry fodder and protein yield over nitrogen application. Application of F<sub>2</sub> significantly imported the above mentioned traits over N alone during both the years and in pooled analysis. The findings of the present investigation are in corroboration with the findings of Roy and Pradhan (1992) and Jayanthi *et al.* (2002).

### REFERENCES

- [1] Choubey, S. and N.K. Prasad. 2001. Nutrient economy and herbage productivity in oat (*Avena sativa*) + berseem (*Trifolium alexandrinum*) intercrop association. *Indian J. Agron.* 46(3): 445-448.
- [2] Jayanthi, C., P. Malarvizhi, A.K. Fazullah Khan and C. Chinnusamy. 2002. Integrated nutrient management in forate oat (*Avena sativa*). *Indian J. Agron.* 47(1): 130-133.
- [3] Kumar, Balwinder, U. S. Tiwana and M. L. Mehra. 2010. Fodder yield and quality as influenced by different seed rates of oats, sarson and rye grass in mixture with berseem. *Range Mgmt. & Agroforestry. Symposium issue (A):* 9-10.

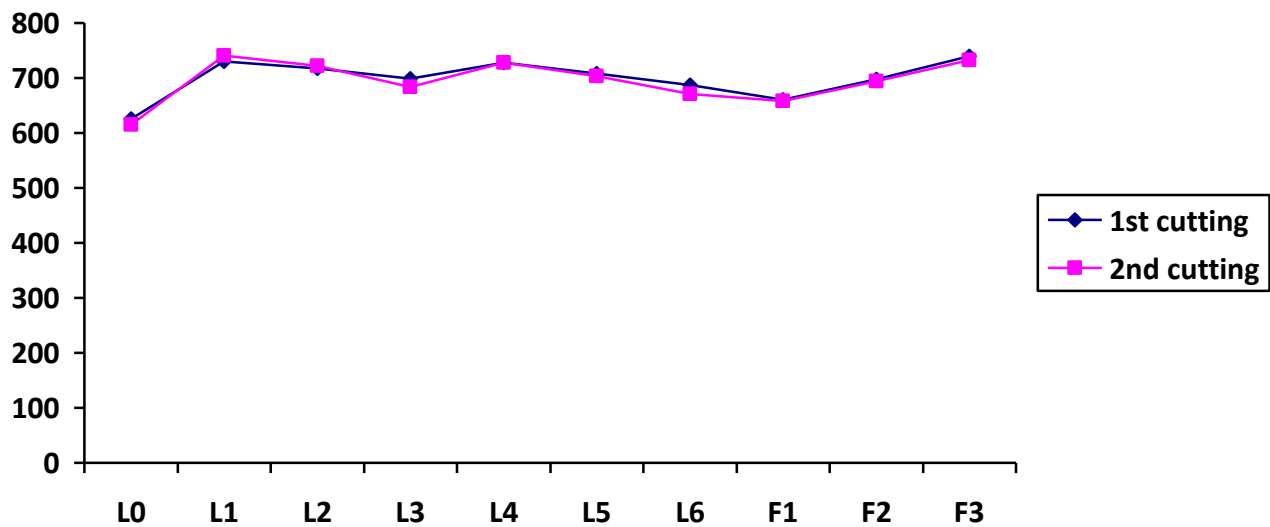
- [4] Puri, K. P., U. S. Tiwana and D. P. Chaudhary. 2010. Fodder yield and quality of ryegrass grown pure and in mixture with different seed rates of oat and sarson. *Indian J. Agron.* 55: 282-285.
- [5] Roy, S.K. and A.C. Pradhan. 1992. Forage and grain yield of oat (*Avena sativa*) as influenced by phosphorus levels and cutting management in soils of West Bengal. *Indian J. Agron.* 37(4): 823-825.
- [6] Tiwana, U. S. and A. Singh (2012). Effect of oat + sarson mixture on the productivity and quality of fodder mixture and seed yield of oat under different cutting management. *Range Mgmt. & Agroforestry* 33 (2) : 177-181.

### AUTHORS

**First Author** – Arjun Kumar Verma, SMS (Agronomy)  
**Second Author** – K. L. Jeengar, Programme Coordinator, Krishi Vigyan Kendra, Jhalawar-326 001, India, Maharana Pratap University of Agriculture and Technology, Udaipur (Rajasthan).

**Table 1. Effect of legume mixtures and balanced fertilization on number of tillers per meter square of fodder oat (Pooled)**

Treatments	Number of tillers per meter square	
	First cutting	Second cutting
<b>Legume mixtures :</b>		
L <sub>0</sub>	625.8	615.0
L <sub>1</sub>	730.3	740.2
L <sub>2</sub>	717.2	722.1
L <sub>3</sub>	698.4	683.3
L <sub>4</sub>	728.1	728.3
L <sub>5</sub>	707.9	703.3
L <sub>6</sub>	687.3	671.1
CD(P=0.05)	37.4	40.1
<b>Balanced fertilization:</b>		
F <sub>1</sub>	660.6	657.8
F <sub>2</sub>	697.9	694.0
F <sub>3</sub>	739.4	732.5
CD(P=0.05)	22.4	23.2



**Figure 1. Effect of legume mixtures and balanced fertilization on number of tillers per meter square of fodder oat (Pooled).**

**Table 2. Effect of legume mixtures and balanced fertilization on green fodder yield and dry matter yield (q/ha) (Pooled)**

Treatments	Green Fodder Yield			Dry matter yield		
	First cutting	Second cutting	Total	First cutting	Second cutting	Total
<b>Legume mixtures :</b>						
L <sub>0</sub>	216.14	203.07	419.21	39.29	37.19	76.48
L <sub>1</sub>	265.33	249.75	515.08	46.31	45.00	91.30
L <sub>2</sub>	253.50	237.08	490.58	42.93	41.65	84.61
L <sub>3</sub>	241.55	223.95	465.50	42.37	40.43	82.80
L <sub>4</sub>	261.21	245.39	506.60	45.41	43.81	89.22
L <sub>5</sub>	251.22	235.17	486.39	43.15	41.71	84.86
L <sub>6</sub>	238.17	222.97	461.14	40.92	39.58	80.50

<b>CD(P=0.05)</b>	13.521	12.696	25.180	2.053	1.942	3.890
<b>Balanced fertilization:</b>						
F <sub>1</sub>	215.90	202.16	418.05	41.10	39.06	80.16
F <sub>2</sub>	239.50	226.52	466.03	42.87	41.39	84.26
F <sub>3</sub>	284.79	264.48	549.27	44.75	43.58	88.33
<b>CD(P=0.05)</b>	7.752	7.296	14.450	1.136	1.194	2.260

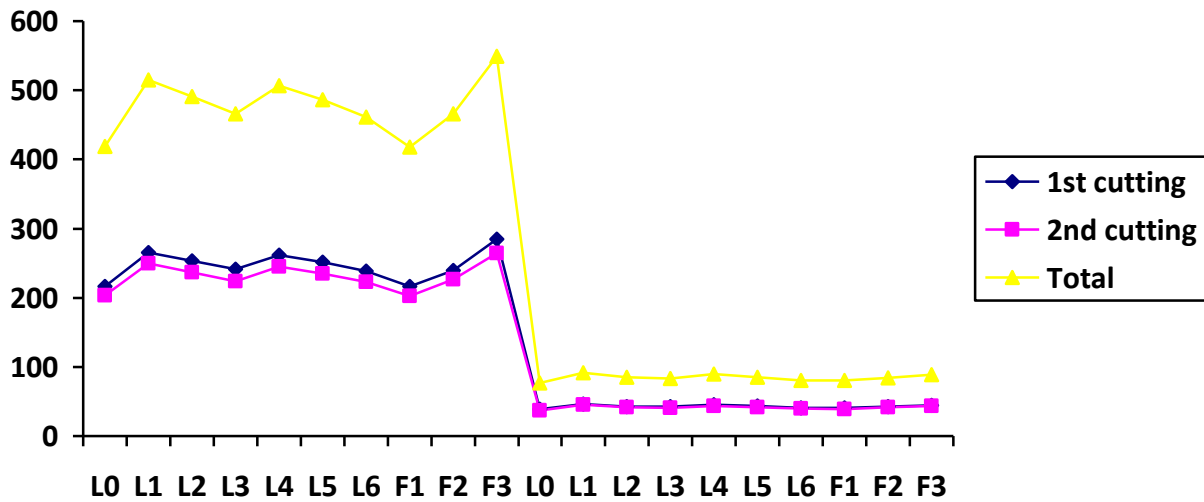


Figure 2. Effect of legume mixtures and balanced fertilization on green fodder yield and dry matter yield (q/ha) (Pooled).

Table 3. Effect of legume mixtures and balanced fertilization on content and production of crude protein of fodder (pooled)

Treatments	Crude protein content (%)		Crude protein production(Kgha <sup>-1</sup> )	
	First cutting	Second cutting	First cutting	Second cutting
<b>Legume mixtures :</b>				
L0	10.11	10.08	398.91	376.41
L1	11.18	11.32	518.39	510.42
L2	10.99	11.00	472.51	459.62
L3	10.94	10.95	464.51	443.61
L4	11.09	11.19	504.41	490.90
L5	10.99	10.96	475.07	457.92
L6	10.93	10.92	447.92	433.02
CD(P=0.05)	0.328	0.334	33.339	31.286
<b>Balanced fertilization:</b>				
F1	10.78	10.84	444.10	425.08
F2	10.92	10.93	469.69	453.75
F3	10.97	10.98	492.69	480.55
CD(P=0.05)	0.151	0.161	18.002	18.896



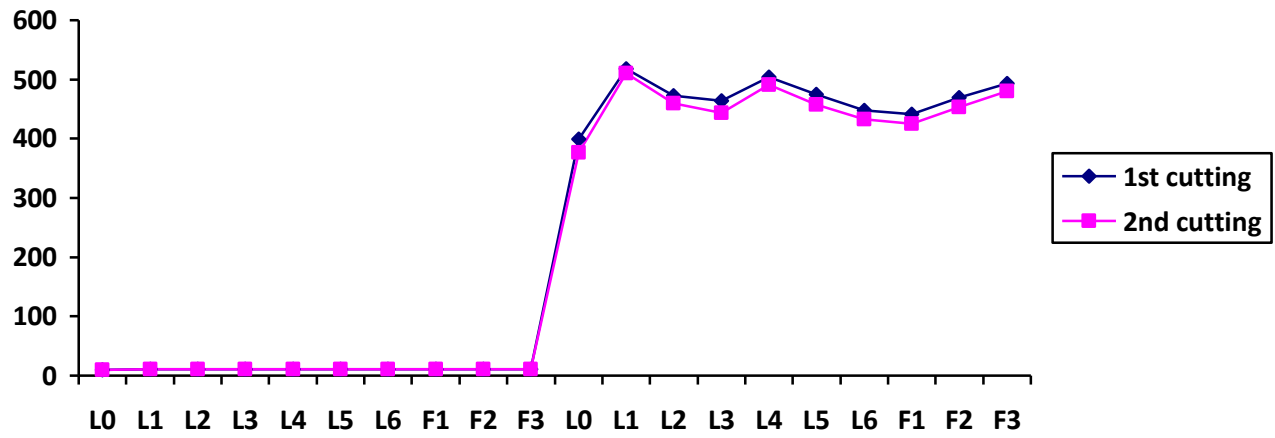


Figure 3. Effect of legume mixtures and balanced fertilization on content and production of crude protein of fodder (pooled)

# Importance of Vegetation in Urban Environment

Prof. Borse Nitin Bajirao

Assistant Professor, Department of Geography, M.V.P Samaj's Arts, Science and Commerce College, Ozar MIG, Nashik (Maharashtra), Affiliated to Savitribai Phule Pune University

**Abstract-** As we generally know that plants and vegetations are very useful for variety of way to human life. It is also useful for maintaining the environmental balance. But in modern times when the rate of urbanization is phenomenal mainly in developing countries the adverse effect of city life are clearly noticed. Very few cities are well planned; otherwise most of urban areas are crowded, polluted and compact. Many experts, planners recommend the green belts and green areas in cities. City life is full of tension. It affects mental health through the influence of the increase stressors and factors such as overcrowded and polluted environment, high levels of violence, and reduced social support. Plants, woodland, lawns are reported as the most desired environment for relaxing and recovering from stress and sustain mental efforts.

Present theoretical paper deals with the concept of urbanization, mental disorders dew to urban environment, importance of plants, trees, and forest in urban landscape.

**Index Terms-** Urbanization, Urban area, mental health, importance of forest

## I. INTRODUCTION

UNO defines health as "Health is a state of complete physical, mental and social well-being and not merely the absence of disease or infirmity."(WHO)<sup>14</sup> now a days the proportion of mental health problems is increasing at an alarming rate in comparison to the physical health problems. Studies made by the World Bank and WHO in 2005, reported that mental health disorders contribute about 10% of global disease burden and that this proportion would increase to 15% in 2020. This is mainly seen in urban areas. An urban area is characterized by higher population density and vast human features in comparison to areas surrounding it. Urban areas may be cities, towns or conurbations.(Wikipedia)<sup>8</sup> The presence of urban trees and forests can make the urban environment a more pleasant place to live, work and spent leisure time.( John F. Dwyer et.al.)<sup>9</sup> Trees and forests contribute positively to increase the quality of life, especially in urban areas. So in this paper an attempt has been made to discuss why the mental problems arise in urban areas and the role of forest and trees in solving them.

## II. MATERIALS AND METHODS

This conceptual research paper is mainly based on the secondary sources of data. Research articles and different web sites were widely used for establishing the facts of growing importance of forests and tree cover in urban areas.

## III. AIMS & OBJECTIVES

1. To understand the types of psychological / mental problems in urban areas.
2. To find out the importance of forests and tree cover in promoting the mental health in urban areas.

## IV. DISCUSSION

The importance of forests is different in rural areas as compared to the urban areas. In rural areas the major advantages of forests are as follows.....

1. Protecting the crops from wind
2. Controlling soil erosion
3. Creating diverse plant and animal habitat
4. Increasing the ground water level
5. Increasing the humus in the soil.

According to the census of India 2011, the urban area is recognized by the following criteria....

- A. All places with a municipality, corporation, cantonment board or notified town area committee, etc.
- B. All other places which satisfied the following criteria:
  - i. A minimum population of 5,000;
  - ii. At least 75% of the male main working population engaged in non-agricultural pursuits;
  - iii. A density of population of at least 400 persons per sq. km.

The urban life is full of rush, tension, competition, pressure, insecurity, isolation and impure environment. This can lead to many diseases. Disturbance in mental health is the major characteristic of city life. Mental health describes a level of psychological well-being, or an absence of a mental disorder. From the perspective of 'positive psychology' or 'holism', mental health may include an individual's ability to enjoy life, and create a balance between life activities and efforts to achieve psychological resilience.( About.com)<sup>1</sup> Whereas The World Health Organization defines mental health as "a state of well-being in which the individual realizes his or her own abilities, can cope with the normal stresses of life, can work productively and fruitfully, and is able to make a contribution to his or her community." (WHO)<sup>13</sup>

If the mental health disturbs, it can cause diseases like anxiety, depression, schizophrenia etc. In the British daily tabloid news paper, **Daily Mail** (June 23, 2011) David Derbyshire explained how the living in urban areas is stressful and makes people vulnerable to depression. He stated that, "Scientists have confirmed what every urbanite has long suspected – life in the city is more stressful. Researchers have shown that the parts of

the brain dealing with stress and emotion are affected by living among the crowds. The findings help shed light on why those who are born and raised in urban areas are more likely to suffer from anxiety, depression and schizophrenia than those brought up in the countryside. Past studies have shown that exposure to green space reduces stress, boosts health and makes us less vulnerable to depression. The findings come from the brain scans of 32 healthy volunteers from urban and rural areas.”

Dr Jens Pruessner of the Douglas Mental Health University Institute in Quebec, who helped carry out the study, said: ‘Previous findings have shown that the risk for anxiety disorders is 21 per cent higher for people from the city, who also have a 39 per cent increase for mood disorders.

‘In addition, the incidence of schizophrenia is almost doubled for individuals born and brought up in cities. (<http://www.dailymail.co>)<sup>7</sup>

Some other researches showed that, the part of the human brain which is involved in mood and emotion was more active in people living in cities. The researchers are unable to find the answer as to why the city life affects the regions of the brain that handles stress. It may be pollution, toxins, crowding or noise. Few studies also showed that the exposure to greenery or forest environment soothes frayed nerves and improves well-being. Even the access of five minutes to forest area reduces the stress. People living in countryside are less likely to have heart disease or heart attacks. According to psychologists human brain has still not developed to cope with the sudden changes that have taken place in last couple of centuries. Every new or strange thing adds to the stress. Human beings have spent many thousands of years adapting to natural environments, yet have only inhabited urban ones for relatively few generations. ([Glendinning 1995](#); [Roszak et al., 1995](#); <sup>5</sup> [Suzuki 1997](#); <sup>12</sup> [Gullone 2000](#))<sup>6</sup>.

Whilst modern ‘westernization’ has doubled our life expectancy, it has also created disparities between ancient and present ways of living that may have paved the way for the emergence of new serious diseases. ‘As more people survive to older age, and as patterns of living, consuming and environmental exposures change, so non-communicable diseases such as coronary heart disease, diabetes and cancer have come to dominate’ [[McMichael, 2001](#) (p. 2)].<sup>11</sup> Further, mental, behavioural and social health problems are seen to be increasing health burden in all parts of the world ([Desjarlais et al., 1995](#)).<sup>4</sup> In the last few hundred years, there has been an extraordinary disengagement of humans from the natural environment ([Axelrod and Suedfeld, 1995](#);<sup>2</sup> [Beck and Katcher, 1996](#); <sup>3</sup> [Katcher and Beck, 1987](#))<sup>10</sup>. This is mostly due to the enormous shift of people away from rural areas into cities ([Katcher and Beck, 1987](#))<sup>10</sup>

## V. CONCLUSION

It is found that green patches, plants, trees can have positive effect on wellbeing of urban population. People were psychologically benefited by just viewing water bodies or greenery. Forest and Greenland in urban landscape reduces the negative effects of daily stresses.

## VI. RECOMMENDATIONS

1. Establishment of Urban Biosphere Reserves through urban planning and ecosystem management.
2. Contact with nature in an urban park environment may be experienced via various means, including viewing natural scenes, being in natural settings, encountering plants and animals, participating in recreational activities, undertaking environmental conservation work, and participating in nature-based therapy programmes, amongst urban population.
3. Improve the designs of building with more windows, open spaces and more exposure to greenery etc.
4. The surroundings of community places, offices, schools and colleges, hospitals should have more greenery and open spaces.
5. Encouragement to eco tourism, agro tourism etc.
6. Create awareness among urban population about the importance of trees, forests and exposure to green spaces with reference to positive mental health.

## ACKNOWLEDGEMENT

Smt. R.C.Pawar provided the valuable information in this work. Discussion with her will be beneficial for understanding the mental health problems of urbanization. Her help is deeply appreciated.

## REFERENCES

- [1] About.com (2006, July 25). What is Mental Health? Retrieved June 1, 2007, from About.com
- [2] Axelrod, L. J. and Suedfeld, P. (1995) Technology, capitalism, and christianity: are they really the three horsemen of the eco-collapse? *Journal of Environmental Psychology*, 15, 183–195.
- [3] Beck, A. and Katcher, A. (1996) *Between Pets and People: The Importance of Animal Companionship*. Purdue University Press, West Lafayette, Indiana.
- [4] Desjarlais, R., Eisenberg, L., Good, B. and Kleinman, A. (1995) *World Mental Health: Problems and Priorities in Low-income Countries*. Oxford University Press, New York.
- [5] Glendinning, C. (1995) Technology, trauma and the wild. In Roszak, T., Gomes, M. E. and Kanner, A. D. (eds) *Ecopsychology: Restoring the Earth, Healing the Mind*. Sierra Club Books, San Francisco
- [6] Gullone, E. (2000) The biophilia hypothesis and life in the 21st century: increasing mental health or increasing pathology? *Journal of Happiness Studies*, 1, 293–321.
- [7] <http://www.dailymail.co.uk/sciencetech/article-2006988/A-rural-life-better-Living-concrete-jungle-really-stressful-make-vulnerable-depression.html>.
- [8] [http://en.wikipedia.org/wiki/Urban\\_area](http://en.wikipedia.org/wiki/Urban_area)
- [9] John F. Dwyer et al. (1992) Assessing The Benefits and Costs of The Urban Forests, *Journal of Arboriculture* 18(5): Sept. 1992, pg. 229
- [10] Katcher, A. and Beck, A. (1987) Health and caring for living things. *Anthrozoos*, 1, 175–18
- [11] McMichael, T. (2001) *Human frontiers, environments and disease. Past patterns, uncertain futures*. UK University Press, The Syndicate of the University of Cambridge, Cambridge.
- [12] Suzuki, D. (1997) *The Sacred Balance: Rediscovering Our Place in Nature*. Allen and Unwin, St Leonards.
- [13] WHO (2013) "Mental Health: Strengthening Our Response (Fact sheet No. 220)" (in English) of World Health Organization. Retrieved 3 February 2013.

- [14] WHO(1946) Preamble to the Constitution of the World Health Organization as adopted by the International Health Conference, New York, 19-22 June, 1946; signed on 22 July 1946 by the representatives of 61 States , Official Records of the World Health Organization, no. 2, p. 100

#### AUTHORS

**First Author** – Prof. Borse Nitin Bajirao, Assistant Professor,  
Department of Geography, M.V.P Samaj's Arts, Science and  
Commerce College, Ozar MIG, Nashik (Maharashtra), Affiliated  
to Savitribai Phule Pune University, e mail: nbborse@gmail.com

# Persistence of Farmer-Herder Conflicts in Tanzania

Davis Mwamfupe

Department of Geography, University of Dodoma, Tanzania

**Abstract-** The study was conducted to examine the factors that have contributed to the causes and persistence of farmer-herder conflicts in Tanzania. The work is anchored on the fact that there have been numerous efforts by the government to bring to an end the conflicts between farmers and herders but these conflicts have been escalating and are becoming economically and socially unbearable. Respondents for the study included farmers, herders, and district level officials in Kilombero, Kiteto, Rufiji and Kilosa districts. Focus Group Discussions were conducted to collect information on conflict resolution mechanisms and the persistence of the conflicts in their areas. Key informants interviews and discussions involving individual farmers, herders, village leaders and district government leaders were also conducted. Major factors for the persistence of conflicts between farmers and herders were found to include policy deficiencies and contradictions, insecurity of land tenure, inadequacy of capacity of the local institutions, corrupt practices, poor coordination in resettling the migrants, inadequate capacity in village land use planning, and the heavy handed approaches used to resolve the conflicts. The study concludes that the root cause of the conflicts is the lack of security of land tenure to smallholder farmers and herders who hold and use unsurveyed land that is liable for alienation through acquisition and encroachment. Unless the government reviews its land policy to ensure security of land tenure land grabbing and corrupt practices will escalate and lead to further conflicts.

**Index Terms-** Farmer-herder conflicts, Land tenure, Land policy, Tanzania.

## I. INTRODUCTION

Land in Tanzania as throughout much of Africa is a primary asset for survival and a major source of income and livelihoods for the rural population. Land is not only a source for livelihoods and valuable economic asset but also carries spiritual values with it. Therefore, access to landed resources is not merely a matter of productive use of the ecological environment; it involves power and symbolic relations (Meur et. al., 2006). In this way, land resources have continued to have major historical, cultural and spiritual significance (Odgaard, 2006, the Encyclopedia of Earth, 2008). Due to increased population pressure and the diversification of rural land use patterns in Tanzania (i.e. expansion of settled and ranching farming, national parks, towns and settlements) access to pasture and water for livestock has diminished thus prompting pastoralists to migrate to the central, eastern and southern parts of the country (Odgaard, 2005, Mattee and Shem, 2006). The squeezing out of pastoralists from their traditional grazing lands has spurred the tension and conflicts with farming communities. In view of the

growing magnitude of the problem and the gravity of the consequences associated with these conflicts the government has put in numerous efforts to address the problem. However, the conflicts persist and in some cases they have escalated. Therefore, this paper seeks to examine the factors contributing to the persistence and escalation of farmer-herder conflicts in Tanzania.

## II. METHODS

The findings discussed in this paper are based on a series of surveys in four districts of Kilombero, Kiteto, Rufiji and Kilosa conducted between 2012 and 2014. These are among the many districts in the country where farmer – herder conflicts have been reported to be on the increase in recent years. Pastoral and agro-pastoral ethnic groups in this study include the Maasai, Barabaig, Sukuma, and Kwavi and to a lesser extent the Gogo. Focus Group Discussions (three in each district) were conducted to collect information on conflict resolution mechanisms and the persistence of the conflicts in their areas. The size of the groups ranged from 8 to 12 people including both farmers and herders at village level. At the district level only one group was conducted for the district officials. Key informants interviews and discussions involving individual farmers (12), herders (10), village leaders (4) and district government leaders (8) were conducted and these provided valuable insights into the findings.

## III. AN OVERVIEW OF FARMER-HERDER CONFLICTS IN SUB-SAHARAN AFRICA

A wide body of scientific literature on Sub-Saharan Africa has consistently acknowledged the historical co-existence of farmers and herders in symbiotic relationships (Bassett, 1988). Seddon and Sumberg (1997) also acknowledge the long historical record of fluctuating conflict, competition and co-operation between settled farmers and pastoral or transhumant herders in the continent. Such relationships were realized through reciprocity, exchange and support (Moritz, 2010). This however, did not mean that conflicts between farmers and herders were non-existent (Bovin, 1990). Quite to the contrary, these relationships were characterized by both conflict and complementarity and were actually two faces of the same coin. Turner (2003) also reports that the relationships between farmers and herders in the Sub-Saharan Africa have always been multi-dimensional and like most social relationships they have involved both cooperation and conflict.

Hussein (1998) further posits that the relations between farmers and herders have always moved between cooperation, competition and conflicts. Tonah (2006) reports that in West Africa, for example, the conflicts between farmers and herders



have been a common feature of economic livelihoods in the area. These conflicts, however, were contained by customary institutions that were functioning following the principle of reciprocity and resolutions which were found within the confinement of the local communities. In addition, intermarriage between groups played part in strengthening these systems and increased the incentives to resolve the conflicts (Sandford and Ashley, 2008). Only in very rare cases were these conflicts brought to state administrative authorities for resolutions.

In recent decades farmer-herder conflicts<sup>35</sup> in many parts of Sub-Saharan Africa have escalated into widespread violence, loss of property, massive displacement of people and loss of lives (Hussein, Sumberg and Seddon, 2000). This situation has been caused by increasing pressure on resources and decreasing efficiency of traditional conflict-management mechanisms (Thebaud and Batterbury, 2001). Factors such as inadequate grazing reserve and stock routes; changes in land tenure system; insufficient legislation pastoralism; expansion in agricultural policies; economic factors and climate change have also been identified as the long-term causes of the conflicts. Hagberg (1998) argues that conflicts between farmers and herders originate from competition for resources caused by population growth, migration and land degradation. Davidheiser and Luna (2008) also cite factors such as international development projects, demographic changes, and environmental degradation to have contributed to the conflicts. More emphasis is placed on changes in production systems and land tenure regimes as central to the aggravation of farmer-herder goal incompatibility and inter-communal strife. Further analysis of the causes reveals that of the changes are the deliberate results of interventions and legislation that were based on Western models and intended to increase production outputs and market integration.

In Northern Africa the relationship between herders and farmers has, for centuries, been shaped by both *cooperation and violence* (Shettima and Tar, 2008). Recently however, strong population growth, wide-spread food insecurity and a recent series of drought events have increasingly challenged traditional resource sharing mechanisms while fights for scarce land resources have intensified (Fratkin and Roth, 2005; Herrero, 2006; ILRI, 2006).

In addition to the demographic and environmental factors for the conflicts two issues also emerge. One is the weakening of the traditional institutions for managing the conflicts, and the second is the changes in regimes of tenure on land. Ahmadu (2011) argues that in Nigeria as in many other parts of West Africa both farmers and herders believe that the evolution of modern state has altered their community-based traditional conflict management systems that developed on the sanctity of traditional norms and values. Even the mechanisms of resolving the conflicts have been weakened and that the tendency is more toward calming down conflicts rather than solving them. There

have been changes to communal land tenure regimes which have in turn, led to tensions and legal conflicts between farmers and herders. In most such situations the state actors are not neutral arbitrators but they are instrumental in the production of institutional uncertainty and create a discrepancy between resources in-flow and weak regulations which in turn generate room for opportunistic behaviors and conflict emergence (Meur et. al 2006).

#### IV. FARMER-HERDER CONFLICTS IN TANZANIA

The conflicts over land use especially between farmers and livestock keepers in the country are contributed by land tenure contradictions between customary and granted land rights (Simbarashe, 2012) and accumulation of land in the hands of big national and multinational companies, leaving small-scale producers landless (Chachage, 2010). These two problems have affected the pastoralists more than other resource users. Almost everywhere in the country, pastoralists are now losing their traditional grazing lands to sedentary farming and national reserves. The loss of land is also contributed by government's view that transhumance pastoralism is backwards and would like communities practicing it to change their way of life and settle in one place (Kipuri and Sørensen, 2008).



Traditionally, land use conflicts in the country were experienced in the margins between pastoral lands and protected lands, especially national parks in Northern Tanzania. In recent decades however, farmer-herder conflicts have increased in magnitude and spread southward and south eastwards of the country covering Kilosa, Mvomero, Kilombero districts of Morogoro Region, Kiteto District in Manyara Region, Rufiji and Mkuranga districts of Coast Region, Kilwa District in Lindi Region, Mbarali District in Mbeya Region and parts of Kongwa in Dodoma Region. Other districts include Handeni and Kilindi in Tanga Region. Farmer-herder conflicts are also occurring in parts of Rukwa and Tabora regions. What is most notable with these districts is that except for Mbarali, Kiteto and Kongwa districts none of the remaining districts fall into the category of what can be characterized as traditionally important areas for livestock keeping. That is, these conflicts are now being witnessed in predominantly crop cultivating areas which had no prior experience of livestock keeping, let alone experiences of other resource use conflicts. Indeed, this partly explains why farming communities label the herders as "invaders".

Such has been the magnitude of the conflicts that state intervention has been found necessary. For example, the government of Tanzania has, in several occasions made efforts to address the conflicts involving farmers and herders. One such measure has been the eviction of livestock (with their owners) from fragile ecosystems where the conflicts have been over the need to gain access to water. Eviction of livestock keepers from Ihefu and Kilombero wetlands are two such examples. In some other cases the government has been prompted to split village lands into areas for farmers and others for livestock keepers. Kambala village in Mvomero District offers such an experience where the village was split into two parts one for each of the major land uses – grazing and crop cultivation. Same measures were also applied in Sagamaganga village in Kilombero District

<sup>35</sup> The term "conflict," is used as an umbrella term to encompass a range of phenomena like lack of convergence of goals, interests, and expectations among social groups; the intentional pursuit of actions or livelihood strategies that result in damage to others; open confrontations resulting from conflicting interests or damaging actions; and recourse to various forms of violence (Hagberg, 1998; Hussein, 1998).

where district leadership set aside one block of land for livestock keeping and another for crop cultivation. Setting aside land for the livestock keepers has gone hand in hand with nationwide campaigns to urge them to reduce their herd size in order to avoid conflicts with other resource users and safeguard the environment. In addition, there have been efforts to hasten the process of village land use planning for the purpose of having efficient utilization of land resources which in turn would contribute to lessening the conflicts between farmers and herders.

Despite these enthusiastic efforts by the government the conflicts have been escalating and the ensuing consequences are becoming socially and economically unbearable. In some extreme cases these conflicts have resulted into bloody clashes and loss of property and lives. A closer look into these interventions clearly reveals that very little has been done to seek solutions that go beyond just satisfying the parties' interests. As such they have failed to identify and deal with the underlying sources of the conflict. At best these interventions have been geared towards conflict management which involves the control, but not resolving the long-term and deep-rooted sources of the conflicts.

Efforts towards managing, or on some rare cases, resolving the farmer-herder conflicts have yielded dismal success largely because they are based on erroneous and misplaced understanding of the conflicts. In addition, government interventions have not addressed the underlying problem of lack of security of tenure for lands being used for different activities. A detailed account of the problems underlying government failure to resolve the conflicts is provided in the subsequent sections of this work.

## V. FACTORS FOR THE PERSISTENCE OF THE CONFLICTS

A number of factors have been identified to contribute to the persistence of farmer-herder conflicts in Tanzania. These factors include; policy deficiencies and contradictions, insecurity of land tenure, inadequacy of capacity of the local institutions, corrupt practices, lack of coordination in planning for resettlement, inadequate capacity in village land use planning, and the heavy-handed approaches used to resolve the conflicts. However, it is important to note that no single factor can adequately explain the persistence of the conflicts between farmers and herders over the years, instead a combined effects of these factors is responsible for the worsening situation.

### ***Policy deficiencies and contradictions***

The Land Policy in Tanzania (through the Land Act and Village Land Act in 1999) classifies land as: Reserved land; Village land; and General land. Reserved land is statutorily protected as national parks, land for public utilities, wildlife and game reserves and other land designated by sectoral legislation. Village land is the land which is within the demarcated or agreed boundaries of any of Tanzania's villages. This land is under the managerial authority of the Village Councils, which are answerable for land management decisions to the Village Assembly.

General land is a residual category and includes all public land which is not reserved land or village land *and includes*

*unoccupied or unused village land*". The definition of General Land is ambiguous because *unoccupied or unused village land* is considered as "excess" and thus falls under the jurisdiction of the Land Commissioner rather than the village authorities. The seemingly unoccupied lands (village) may be important areas for seasonal livestock grazing, and other important livelihood uses (Mattee and Shem, 2006). Certainly this ignores the fact that as the population grows this "excess" village land will actually be brought into use. However, this is actually the same land which is, in most cases identified as suitable for agricultural investment. Not coincidentally and under the pretext of large scale agricultural investments the land belonging to farmers and pastoralists is subject to appropriation by state-backed investors. Thus, the pastoralists occupying semi-arid areas are often subject to efforts to alienate their customary pastures and land holdings, for purposes of commercial investments or establishment of wildlife conservation areas (Mattee and Shem, 2006). The land policy has some deficiencies because it does not guarantee security of tenure to some users, especially smallholder groups. In effect, these deficiencies have led large areas of land being given over to alternative uses and consequently marginalizing the pastoral populations (Bonfiglioli, 1992).

✚ Appropriation of land from pastoralists in Tanzania like elsewhere in Africa is usually backed by the enduring perception that pastoralism is an irrational, ecologically destructive and economically inefficient production system (Homewood 1995; Hesse and MacGregor, 2006). These perceptions have consequently resulted into efforts by government policy makers to re-distribute pastoral lands directly to commercial investors in the belief that this is an economically rational policy (Sulle and Nelson, 2009). The squeezing out of herders to give way to large scale seed farms in Arusha Region in Northern Tanzania typifies the argument here and bears witness to the limits of policy makers' understanding of the nature of pastoralism. Suffice to point out that as long as the pastoralists continue to be squeezed out of their traditional grazing lands migration into other parts of the country in search of pastures and the subsequent conflicts can't be avoided.

✚ Another area where policy deficiencies are conspicuously revealed is on the Grazing-Land and Animal Feed Resources Act which translates and implements the National Livestock Policy of 2006. The Act provides guidance for the management and control of grazing lands and animal feed resources. Some of the problems identified in the Act include the interpretation of the terms used. For example, the Act defines "communal grazing land" to mean a grazing land owned by a "livestock keeper" and it defines the "livestock keeper" as a person who engages on livestock keeping for "production." The term "production" is defined as rearing animals for commercial purpose. The pastoralists hence argue that the Act does not provide for the protection and promotion of pastoralism but exclusively focuses on commercial livestock keeping. It is argued that the persistence of farmer-herder conflicts in the country is a reflection of the government's failure to strike a balance between the promotion of investment (of which private interests of government policy-

makers may themselves be involved), and the land access interests of smallholder farmers and pastoralists.

In addition to policy deficiencies, there is also a problem of contradictions of the policies. This is supported by Lugoe's (2011) argument who asserts that there is some misalignment between the Livestock Policy (of 2006) and the National Land Policy. The Livestock Policy recognizes seasonal movement as an important characteristic of pastoralism and thus encourages livestock owners in overgrazed areas to move to lower stocked areas. The Livestock Policy has gone further and facilitated modalities for new settlements for pastoralists. In contrast to this spirit, the National Land Policy prohibits nomadism and all its different forms—modern or transhumant. Such contradictions help to sow seeds of hostilities between the pastoralists and implementers of the policies.

## VI. LACK OF SECURITY OF TENURE

At the root of the conflicts between farmers and herders is the lack of security on land that rural producers subsist on. Overall the objective of the land policy is to promote and ensure secured land tenure system that encourages optimal use of land resources and facilitate broad based social and economic development without upsetting or endangering the ecological balance of the environment (Land Policy 1999: 5 section 2.0). The problem of lack of security of tenure facing pastoral groups is best exemplified by eviction of Maasai pastoralists from eight villages of Soitsambu, Oloipiri, Ololosokwan, Loosito/Maaloni, Oloerien Magaiduru, Piyaya, Arash and Malambo in Loliondo District of northern Tanzania. These pastoralists have been occupying this land for over a hundred years. This ownership is legally recognized under the laws of Tanzania, in particular, the Land Act, Cap. 113, the Village Land Act, Cap. 114 and the Local Government (District Authorities) Act, Cap. 287. However, in total disregard of the importance of the grazing land to the livelihoods of pastoral groups the Government of Tanzania granted a commercial hunting license (to a foreign investor) on a land belonging to the eight registered villages. Having lost control of their land which was fundamental to their livelihoods, the evicted pastoralists have been forced to migrate into other parts of the country in search for livelihoods. Yet the same displaced people are being blamed for causing conflicts at the destination points, and this only amount to it is like blaming the victims of land alienation.

At the root of the problem of insecurity of land tenure is the emerging process of land grabbing which has been encroaching on local rights, marginalizing rural farmers and pastoralists who depend on land, water and other natural resources. This has been further emphasized by Nelson et al. (2012) Land-grabbing, with its links to corruption, preferential appropriation of public assets by state officials, and leading politicians' and ruling party financial interests, has been taken up as a central issue in public debates over governance and transparency. In the face of policy deficiencies the state-backed investments have all contributed to this malaise facing the smallholder producers.

### *Inadequate capacity of the local institutions*

The influx of livestock into areas which were once dominated by crop cultivators has contributed to the occurrence and persistence of conflicts between farmers and herders. This has been an inevitable outcome because the cultural values and attitudes which used to provide the basis for interaction and the norms by which individuals and communities live have been altered. At village level the traditional conflict resolution machinery has been weakened partly by the emergence of statutory approaches based on formal procedures, and on the other, by the influx of herders who do not share the values and beliefs upon which these mechanisms were anchored. Elsewhere in Sub-Saharan Africa, it has been also noted that land conflicts are proving more difficult to solve because traditional instruments of conciliation, such as compromise and consensus are failing. On the one hand, local institutions have largely lost their authority, and on the other, few institutional innovations have been developed (Kirk, 1999).

Resolving resource use conflicts at village level falls under the responsibility of the Village Environmental Committees. In all the villages covered by this study the Village Environment Committees are composed by both farmers and herders. In situations where these committees fail, then the cases are referred to next bodies in the hierarchy. It was revealed that none of the members of the committees had received any form of training on conflict resolution skills such as mediation and negotiations. In a number of places in the country the local institutions, such as the Village Environmental Committees, village governments and district machinery have shown to lack capacity to resolve the conflicts. This explains why only a small proportion of the conflicts are resolved at this level. This is actually how the village government leadership comes in. The members of this hierarchical stage too are not equipped with any skills related to conflict resolution. Members of the village government are selected by the villagers and given the higher population of the farmers relative to that of herders even the village government leadership is dominated by crop cultivators. This is a point of contention, especially from the perspective of herders who argue that they are not fairly represented in the village governments and hence their reluctance to cooperate in resolving the conflicts. Underlying these problems is the fact that the statutory procedures of sustaining peaceful and mutual relations have not been strong enough to replace the traditional conflict resolution mechanisms. Elsewhere in Kenya Murithi (2006) underscores that with the disappearance of indigenous conflict resolution mechanisms the tranquility as underscored by the principles of reciprocity, inclusivity and a sense of shared destiny between people remain elusive.

The inadequacy of capacity of local institutions to resolve the farmer–herder conflicts is further compounded by the mistrust that exists between the conflicting parties. The general attitude of herders towards the village governments is negative. *“We would have liked our court cases to be decided and resolved at district level because village government leadership tends to favor farmers, especially in setting the amount of compensation for crop damage. In addition, whenever we demand our rights the village leadership calls in the police but the problems remain”*. On the other hand, the farmers too do not trust district level officials whom they accuse to favour the herders. *“District level officials always favor the herders because the livestock is a*



*new source of revenue, and in some ways these officials may have full knowledge on the actual owners of part of the livestock herds. In this way these officials work with full orders from high ranking politicians who may also own part of the livestock, and thus contributing to the arrogance of the herders*". Two things are evident in this hierarchical process of resolving the conflicts. First, local institutions lack capacity in terms of negotiating and mediation skills that are important in conflict resolutions. Second, both the herders and farmers do not trust the local institutions, both at village and district levels, and this partly explains the reluctance to cooperate in resolving the conflicts.

#### ***Nature of approaches used to resolve and manage the conflicts***

Part of the reasons for the persistence of farmer – herder conflicts lies in the way the conflicts are being handled. The use of excessive force involving the police is not only unsustainable but also deepens the hatred between the conflicting parties. At best this approach is good for imposing short-lived peace but the problems still remain. This is not uncommon in Sub-Saharan Africa; otherwise Moritz (2003) provides evidence on the nature of government responses to farmer – herder in Nigeria where army and the police are used to manage or sometimes to resolve the conflicts. At the district level, the management of farmer-herder conflicts nearly throughout the country is dealt with by the District Defense and Security Committee. The members of the committee are the Militia Advisor, District Executive Director, District Prisons Commander, Police, The Prevention and Combating of Corruption Bureau (PCCB) and District Security Officer. Such a composition shows a heavy military presence with very little or none use of mediating or even negotiating skills. In some cases this may appear like a military operation – thus causing further problems of hatred between the conflicting parties and towards the government in general.

#### ***Corruption and ‘politics of the belly’***

Corrupt practices also contribute to the persistence of farmer-herder conflicts. This problem can be looked at from two perspectives –at village level involving local leadership, and higher levels of government involving highly placed politicians and government leaders (politics of the belly). At the local level village leadership has the responsibility of maintaining peace and security. This also entails fair allocation of land to different uses. In the wake of the influx of livestock then village leadership has the responsibility of ensuring that there is a balance between the number of livestock herds and the available resources. In all villages covered by this study there were complains that village leaders had received bribes to allow large herds of cattle well beyond the capacity of the village resources to support. Another area of discontent and where corrupt practices are believed to exist is the assessment of damage to crops caused by livestock. In nearly all villages studied herders complained that village leaders receive bribes from farmers to exaggerate the damages in order to get higher compensation. On the other hand, farmers also accuse district level leadership of receiving bribes from herders to have their court cases settled in their favour. Maganga (2007) had earlier noted this problem in Mvomero district that corruption had the effect of undermining people’s trust in authorities and the willingness of these authorities to prevent conflicts.

The second perspective of corruption involves influential politicians well beyond the village level. This is described using the phrase ‘politics of the belly’. This is an expression implied in the proverb ‘goats eat where they are tethered’ (Bayart, 1993) to describe a system where officials on different levels systematically exploit political power and authority, and appropriate public resources for their own benefits and purposes, or more specifically; “accumulation of wealth through tenure of political power”. Under this system an individual especially politicians negotiate the institutional ambiguity and complexity to pursue their own interests (Moritz, 2006). It is further argued that that ‘Belly politics’ is based on a hierarchy in which “smallholders are steadily losing out to the wealthy, powerful, and better connected elite, who are much better positioned in these ‘negotiations’(Moritz, 2006). This situation is also evident in the districts covered by this study.

*Kambala village in Mvomero district is one of the areas where farmer-herder conflicts have led to loss of property and lives. Part of the solution to resolve the conflicts involved splitting the village land into two villages, one for herders and another for farmers. Later on, there were allegations that some district and regional leaders acquired the land that had been set aside for pastoralists. Large scale farms were established and thus causing further squeezing out of the herders, and thereby causing more conflicts. Obviously the politicians and businessmen had taken advantage of the village lacking land use plans and these made it easy to process and obtain title deeds. With these documents in their hands these politically influential people have a more secure access and control of the land than the original owners – the farmers and herders. With lesser land available for the ever growing demand escalation of the conflicts could not be avoided. Therefore, seemingly good solution for the conflicting parties ended to benefit the “mediators” – government officers and influential business people in the area.* Some administrative officials are also accused of making financial gains from conflicts. For example, local politicians looking for votes often promise farmers they would expel the strangers. Benjaminsen and Boubacar (2008) point out that government officials may indeed use their powers to exploit institutional ambiguity to the detriment of the poor in farmer herder land use rivalry, and argue that in order to understand the origins and catalysts of the conflict it is important to know also the interests and motives of individual actors in the process of protection and assurance of rights. In a number of districts covered by this study the district level officers reported that they can’t reveal so openly the results of their investigations on the conflicts for fear of either being transferred to more remote districts or even losing their jobs. Part of the explanation for this fear is that in some villages, part of the livestock herds belong to highly placed politicians and government leaders.

#### ***Lack of coordination in resettling the herders***

As part of the solution to halt the degradation of wetlands in Kilombero basin and Ihefu water catchments in Usangu plain the government ordered the eviction of livestock herds from these ecologically fragile areas. These herders were later settled in Kilwa and Rufiji districts in the south of the country. However, there wasn’t adequate planning and sensitization of the host communities prior to the resettlements of herders. In effect, this

approach was tantamount to shifting the problem from one area to another. For example, the eviction of livestock herds from Usangu plains and Kilombero valley contributed to the emergence of resource use conflicts in the destination areas of Rufiji River basin.

The farmers in Rufiji district complained that there were no consultations with the host communities prior to the resettlement of the herders from Kilombero and Usangu areas. Without such plans the host communities felt that they had been invaded by herders with the assistance of the government. A major point of complaint is that the livestock has contributed to degradation of rice fields and consequently leading to reduced productivity of the land. Seemingly trivial as this may appear, it has contributed to the growth of hatred between the host and 'stranger' communities because it has had negative impacts to the livelihoods of the former group.

The ensuing conflicts between farmers and herders are further complicated by the fact that parts of the lands in Rufiji district have been allocated to investors for biofuels production. In effect this means less land for both the farmers and herders. The presence of the Selous Game Reserve in the south western side of Rufiji district also means limited space for the expansion of farming land and at the same time puts limits to the mobility of livestock. With more herds of livestock flowing in the district there is less land available per capita. Under such circumstances farmer – herder conflicts become inevitable.

The conflicts involving herders and farmers in Kilwa and Rufiji Districts have taken two dimensions all of which have the effect of perpetuating rivalry between the groups; First dimension is the economic differences between farmers and herders and that the conflicts are now between the rich (herders) and the poor (farmers) or "rich invaders" (and mostly stigmatized as arrogant) against "poor hosts". In most areas affected by conflicts a herder is almost synonymous with a rich person and the farmer is considered poor and this creates a situation of arrogance on the one hand and inferiority on the other, but then discontents between parties still remain. The second dimension is that the conflicts involve groups with different cultures (particularly religion) and that the conflicts are also looked at as ethno-religious or cultural clashes. While ethnic and religious differences may not be very significant factors in explaining the persistence of the conflicts, they are often used by host communities to draw attention and organize collective support among themselves against the 'invaders'.

## VII. LACK OF VILLAGE LAND USE PLANS

The persistence of farmer-herder conflicts is also a result of villages lacking land use plans. Village land use planning is widely accepted as useful tool for rational allocation of land resources to various uses and for promotion of sustainable utilization of resources. This tool has the potential to prevent resource use conflicts among users. However, this is an expensive undertaking and Mango and Kalenzi (2011) report that the average cost per village stands at Tshs 7 million, and this is far more than most villages could afford. With these limitations there is little control in resource use, especially in the face of growing rural population and the consequent increase in the demand for resources.

## VIII. CONCLUSION

Explanation for the persistence and escalation of farmer-herder conflicts in Tanzania have been sought in the confinement demographic and environmental factors. A deeper analysis of the conflicts however, reveals that these factors are only secondary causes. The findings show that the root cause of the conflicts lies mostly in the lack of security of tenure on land that most smallholder producers depend for their livelihoods. Policy deficiencies and contradictions have been exploited by corrupt elite to the detriment of the poor farmers and livestock keepers. In particular, the effects of state-backed land grabbing for large scale agricultural investments and corrupt practices at village and district levels have all contributed to the squeezing out of herders from their traditional grazing lands. The effects of such misplacement have had their ripples felt in farmer communities in the form of resource use conflicts. It is also concluded that in the absence of land use plans for most villages in the country coupled with lack of coordination in resettling the displaced migrant herders, conflicts with farmers in an inevitable outcome. Therefore, unless security of tenure on land used by smallholders (both farmers and herders) is restored the conflicts between them will continue. This is necessary in order to prevent the conflicts from assuming a political dimension, a situation which will become uncontrollable.

## REFERENCES

- [1] Ahmadu H. J. (2011). Farmer-herder conflict: Exploring the causes and management approaches in the Lake Chad region Nigeria: being a dissertation submitted in fulfillment of the requirements for the award of Doctor of Philosophy, College of Law, government and international studies, University Utara Malaysia.
- [2] Bassett, T.J. (1988). 'The Political Ecology of Peasant-Herder Conflicts in the Northern Ivory Coast', *Annals of the Association of American Geographers* 78(3): 453-472.
- [3] Bayart, Jean-François (1993). *The State in Africa: The Politics of the Belly*. London and New York: Longman.
- [4] Benjaminsen, T. and Boubacar, B.A. (2008) Farmer herder conflicts, pastoral marginalization and corruption: A case study from the inland Niger Delta of Mali. *The Geographical Journal*, 175, 71-81. <http://dx.doi.org/10.1111/j.1475-4959.2008.00312>.
- [5] Bonfiglioli, A.M (1992). Pastoralists at a crossroads: survival and development, issues in African pastoralism. Nomadic pastoralists in Africa project (NOPA) UNICEF, UNSO, Nairobi
- [6] Bovin, M. (1990). 'Nomads of the drought: Fulbe and Wo'daabe nomads between power and marginalization in Sahel of Burkina Faso and Niger Republic' in M. Bovin & L. Manger (eds) *Adaptive Strategies in African arid Lands*, The Scandinavian Institute of African Studies, Uppsala, pp 29 - 59
- [7] Brockington, D. (2002). *Fortress Conservation: the preservation of the Mkomazi Game reserve, Tanzania*. James Currey, Oxford
- [8] Chachage, C. (2010). 'Land acquisition and accumulation in Tanzania: The case of Morogoro, Iringa and Pwani regions, 'Available at; <http://www.commercialpressureonland.org/research-paper/land-acquisition-andaccumulation-tanzania>. [Accessed 19/3/2013]
- [9] Coast, E. (2000). *Maasai Demography* Unpublished PhD University of London
- [10] Coast, E. (2002). 'Maasai socio-economic conditions: cross-border comparison' *Human Ecology* 30 No. 1 pp.79-105
- [11] Davidheiser, M. and A. M. Luna (2008). From Complementarity to Conflict: A Historical Analysis of Farmer-Fulbe Relations in West Africa, *African Journal on Conflict Resolution* Vol. 8 (1) 2008: pp. 77-104



- [12] Fratkin, E., and Roth, E. A.: The Setting. In: Fratkin, E., Roth, E. A., and Nathan, M. (Eds.): *As Pastoralists Settle*; pp. 29 –52. New York (NY, USA): Kluwer Academic/Plenum Publisher 2005
- [13] Galaty, J. (1999). 'Grounding pastoralists: law, politics and dispossession in East Africa' *Nomadic peoples* 3 2., 56-73
- [14] Herrero, S.: Desertification and environmental security. The case of conflicts between farmers and herders in the arid environments of the Sahel. In: Kepner, W. G., Rubio, J. L., Mouat, D. A., and Pedrazzini, F. (Eds.): *Desertification in the Mediterranean Region. A Security Issue*; pp. 109 – 132. NATO Security through Science Series C. Environmental Security 2006
- [15] Hesse, C. and MacGregor, J. (2006). *Pastoralism: Drylands' invisible asset?* IIED Drylands Issue Paper No. 142. IIED, London, UK.
- [16] Homewood K, Thompson M and Coast E (2004) In-Migrants And Exclusion: tenure, access and conflict in east African rangelands. *Africa* 74 (4), 567-610
- [17] Homewood, K. (1995). 'Development, Demarcation and Ecological Outcomes in Maasailand', *Africa* 65(3): 331-350.
- [18] Homewood, K. (2004). Policy, Environment and development in African rangelands. *Environmental Science and Policy* 7, 125-143
- [19] Hussein, K. et al (1998). Conflict between Farmers and Herders in the semi-arid Sahel and East Africa: A Review. *Pastoral Land Series* 10. London: IIED/OD Group.
- [20] Hussein, K., J. Sumberg, and D. Seddon (2000). Increasing violent conflict between herders and farmers in Africa: claims and evidence. *Development policy review* 17:397-418
- [21] Igoe, J. and Brockington, D. (1999). 'Pastoral land tenure and community conservation in East African rangelands: a case study from northeastern Tanzania'. *Pastoral Land Tenure Series* 11. IIED, London
- [22] ILRI (International Livestock Research Institute): Exploring farmer-herder relations and conflict management in Niger. (2006) <<http://www.ilri.org/ilri/news/index.php/archives/474>>
- [23] Kamanga, K.C. (2008). *The Agrofuel Industry in Tanzania: A Critical Enquiry into Challenges and Opportunities*. A Research Report. Hakiardhi and Oxfam Livelihoods Initiative for Tanzania (JOLIT), Dar es Salaam.
- [24] Kipuri, N., and Sorensen, C (2008). Poverty, Pastoralism and policy in Ngorongoro. Lessons learned from ERETO 1 Ngorongoro Pastoralist Project with Implications for pastoral development and the policy debate: ERETO/IIED
- [25] Kirk, M. (1999). The Context for Livestock and Crop-Livestock Development in Africa: the Evolving Role of the State in influencing Property Rights over Grazing Resources in Sub-Saharan Africa. In: McCarthy, N. : B. Swallow; M. Kirk and P. Hazell (eds.) *Property Rights, Risk, and Livestock Development in Africa*. IFPRI and ILRI.
- [26] Klopp, J. (2001). "Ethnic clashes" and winning elections: the case of Kenya's electoral despotism.' *Can.J. Afr Studies* 35 3. 473-515
- [27] Lugoe, F. (2011) *Aligning and harmonizing the livestock and land policies in Tanzania*. ESRF Discussion Paper No. 35. Economic and Social Research Foundation, Dar es Salaam
- [28] Maganga, F.P., R. Odgaard and E. Sjaastad (2007). 'Contested Identities and Resource Conflicts in Morogoro Region, Tanzania: Who is Indigenous', in B. Derman, R. Odgaard and E. Sjaastad (eds) *Citizenship, Identity and Conflicts over Land and Water in Contemporary Africa*, pp. 202–14. London: James Currey.
- [29] Mango, G and D Kalenzi (2011). *The Study to Develop a Strategy for Establishing Cost Effective Land Use Plans in Iringa and Njombe Regions*, Dar es Salaam
- [30] Mattee, A.Z. and Shem, M. (2006). *Ambivalence and Contradiction: A Review of the Policy Environment in Tanzania in Relation to Pastoralism*. Drylands Issue Paper No. 140. IIED, London, UK.
- [31] Means, K., C. Josayma, E. Neilsen and V. Viriyasakultorn. (2002). *Community-based forest resource conflict management. A training package*. Volumes 1-2. Food and Agriculture Organization of the United Nations, FAO-Rome, Italy.
- [32] Meur, P.L, P. Hochet, M. Shem, O. Touré (2006). *Conflict over Access to Land & Water Resources within Sub-Saharan Dry Lands: Underlying factors, conflict dynamics and settlement processes* GRET-FAO LEAD Final Report
- [33] Mitchell, A. (2008). *The Implications of Smallholder Cultivation of the Biofuel Crop, Jatropha curcas, for Local Food Security and Socio-economic Development in Northern Tanzania*. MSc Thesis, University of London, UK.
- [34] Moritz Mark (2010). *Understanding Herder-Farmer Conflicts in West Africa: Outline of a Processual Approach* Human Organization, Vol. 69, No. 2, 2010
- [35] Moritz, M. (2009). *Farmer-herder conflicts in Sub-Saharan Africa*. The encyclopaedia of Earth. [http://www.eoearth.org/article/Farmer-herder\\_conflicts\\_in\\_Sub-Saharan\\_Africa?topic=49530](http://www.eoearth.org/article/Farmer-herder_conflicts_in_Sub-Saharan_Africa?topic=49530)
- [36] Moritz, Mark (2006). "The politics of permanent conflict: Farmer-Herder Conflicts in Northern Cameroon" in *Canadian Journal of African Studies* vol. 40 (1), 101- 26.
- [37] Moritz, Mark. (2003). "Commodification and the Pursuit of Piety: The Transformation of an African Pastoral System." Dissertation, University of California at Los Angeles.
- [38] Murithi, Timothy (2006). "Practical Peace Making Wisdom from Africa: Reflections on Ubuntu." *The Journal of Pan African Studies*, , 1(4), June, pp.25–34.
- [39] Myenzi Y. (2010). *Current land issues in Tanzania and their implications to small holder farmers: Paper presented to the workshop on land access, ownership and utilization in Tanzania*, Glonecy Hotel Morogoro 6 Sept. 2010
- [40] Nelson Fred, Emmanuel Sulle and Edward Lekaita (2012). *Land Grabbing and Political Transformation in Tanzania* Paper presented at the International Conference on Global Land Grabbing II Cornell University, Ithaca NY, October 17-19, 2012
- [41] Odgaard, R. (2006). *Land rights and land conflicts in Africa: The Tanzania case*. Copenhagen, Danish Institute for International Studies.
- [42] Ofuoku, A (2009). *The Role of Community Development Committees in Farmer-Herder Conflicts in Central Agricultural Zone of Delta State*, *Nigeria Journal of Alternative Perspectives in the Social Sciences* ( 2009) Vol 1, No 3, 921-937
- [43] Sandford, J and S. Ashley (2008). *Livestock Livelihoods and Institutions in the IGAD Region*
- [44] Sanginga, P. C., R. N. Kamugisha, and A. M. Martin. (2007). *The dynamics of social capital and conflict management in multiple resource regimes: a case of the southwestern highlands of Uganda*. *Ecology and Society* 12(1): 6. [online] URL: <http://www.ecologyandsociety.org/vol12/iss1/art6/>
- [45] Seddon, D and J. Sumberg (1997). *Conflict between Farmers and Herders in Africa: an Analysis- Project R6618 Semi-Arid (Rangelands) Production System - Department for International Development (DFID)*
- [46] Shettima, A. G., and Tar, U.: *Farmer-pastoralist conflict in West Africa: Exploring the causes and consequences*. *Information, Society and Justice* 1/2, 163 –184 (2008)
- [47] Simbarashe, M. (2012) 'Land: Efforts needed to end conflicts between farmers and Cattle elders,' Available at; <http://www.dairlynnews.co.tz/index.php/features/popular-features/5820-land-effortsneeded-to-end-conflict-between-farmers-andcattle-holders>. [Accessed 12/12/2014]
- [48] Southgate, C. and D. Hulme. (2000). 'Uncommon property: the scramble for wetland in southern Kenya.' In D.Hulme, P Woodhouse and H Bernstein (eds) *African enclosures? Social dynamics of land and water*. James Currey
- [49] Sulle, E. and Nelson, F., (2009). *Biofuels, Land Access and Rural Livelihood in Tanzania*, IIED, London.
- [50] Thebaud, B., and S. Batterbury (2001) *Sahel pastoralists: Opportunism, Struggle, Conflict and Negotiation. A case study from Eastern Niger*. *Global environmental change* 11:69 – 78
- [51] Tonah, S. (2006). *Farmer –Herder Conflict in Volta region of Ghana*. *Journal of social sciences*.2(1),6-10
- [52] Toulmin, C. (1983). 'Herders and Farmers, or Farmer-herders and Herder-farmers?' *Pastoral Development Network Paper* 15d. London: Overseas Development Institute.
- [53] Turner, M (2004). *Political ecology and moral dimensions of resource conflicts: The case of farmer-herder conflict in the Sahel*. *Political Geography* vol. 23, 863-889.

AUTHORS

**First Author** – Davis Mwamfupe is an Associate Professor in the Department of Geography, University of Dodoma Tanzania. dmwamfupe@hotmail.com, dmwamfupe@uodom.ac.tz

# Effect of Carbon Nanotube on Thermo-Mechanical Properties of Glass Fiber/Epoxy Laminated Nanocomposites

Shubham Gupta<sup>1\*</sup> and Ariful Rahaman<sup>1</sup>

<sup>1</sup>School of Mechanical and Building Sciences (SMBS), VIT-University Vellore-632014, Tamil Nadu, India  
\*Corresponding author: ([shubham.gupta2012@vit.ac.in](mailto:shubham.gupta2012@vit.ac.in))

**Abstract-** Nanocomposites has emerged, penetrated and conquered the market over the past years due to its wide range of applications. The processing of nanocomposites is one of the fastest growing areas in materials research due to the potential of significantly changing material properties even at low nanomaterial concentrations.

The thermo-mechanical behaviors were investigated experimentally for two systems of glass fiber reinforced epoxy composites: with carbon nanotubes (CNTs) and without CNTs. An experimental campaign which involves 4 layers laminates were conducted in this study. A manufacturing process using hand lay-up technique followed by hot pressing techniques was used to produce glass fiber-reinforced laminates with the epoxy matrix and with the CNT based epoxy matrix. The surface characterization and thermo-mechanical behavior of the glass fiber-epoxy system and glass fiber-CNT/epoxy system was characterized through Scanning Electron Microscopy (SEM) and Dynamic Mechanical Analysis (DMA).

**Index Terms-** Carbon nanotube, Nanocomposites, Glass fiber, DMA, SEM.

## I. INTRODUCTION

Composite materials [1] containing carbon fibers/glass fibers are widely used in applications ranging from aerospace to sports equipments. Carbon nanotube based nanocomposite is one of the fastest growing areas of materials research in developing new materials with new and improved properties [2, 3, 4]. The advantages of carbon nanotube based nanocomposites over conventional composites are lighter, high specific strength, high specific modulus, high chemical resistance, high electrical conductivity, etc. Yet, as the use of nanocomposite materials in modern applications is increasing, these materials are now extensively used in primary parts of aeronautical applications. The use of epoxy resin as matrix for the fiber-reinforced composites in the structural applications has been increased significantly [5]. As far as many studies have been achieved on nanocomposites [6, 7], only few investigations were conducted on truly multiscale composites including both fibers and nano reinforcements [8, 9, 10].

The aims of this study are (1) to fabricate glass fiber reinforced laminated nanocomposites using CNT-epoxy resin and (2) to compare the thermo-mechanical properties of glass

fiber reinforced epoxy laminated composites and glass fiber reinforced CNT-epoxy laminated nanocomposites.

## II. EXPERIMENTAL

### A. Material System

The NH<sub>2</sub> functionalized-multiwalled carbon nanotubes (MWCNTs) were supplied by Cheaptube. The manufacturer specified dimensions, diameter (d) ~10-20nm and length (l) ~5-10 μm, are confirmed by SEM observation (Fig 1(a)). According to the manufacturer, the MWNTs material has over 97% nanotube content with very small traces of metals as impurities. Unidirectional (UD) glass fiber has been used as reinforcing material in this study.

Unidirectional (UD) glass fibers from Pearl Industries, New Delhi., have been used as reinforcing material. The surface density of the fabric was 220 g/m<sup>2</sup> and its thickness is 0.18 mm. Average diameter of the fibers is estimated to 20 μm (Fig 1(b)). Epoxy resin Araldite LY556 and the compatible hardener (HY917) used as the matrix were obtained from Ciba Specialty Chemicals.

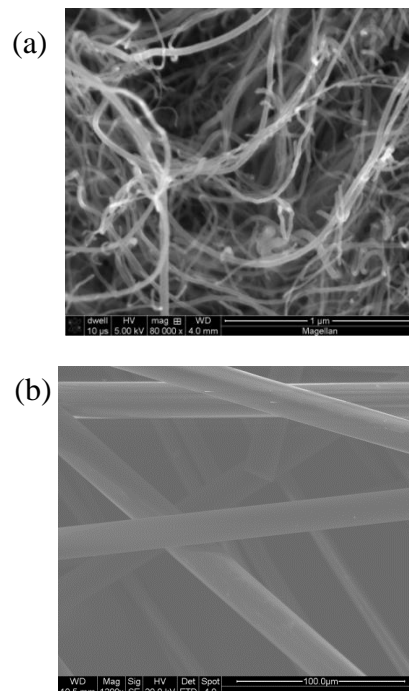


Fig 1. (a) SEM image of MWCNTs and (b) SEM image of glass fiber

**B. Preparation**

*Step 1: Dispersion*

In the first step, the MWCNTs were added into the epoxy in such a way that the final material was 1.0wt% of CNT by wt% in epoxy. Next, this mixture was ultrasonicated by using ultrasonicator as well as stirred using magnetic stirrer for 2 hr at room temperature. After this step, the required amount of hardener was added into the mixture (ratio of 10:9 by weight). It was thoroughly stirred for 15 minutes at room temperature to make a homogeneous mixture.

*Step 2: Curing Behavior*

The cure behavior of epoxy matrix and CNT modified epoxy are characterized by a differential scanning calorimeter (DSC). In the DSC plot, one exothermic peak at 1st run was appeared at 140oC due to the chemical reaction of epoxy and hardener, as shown in Fig 2. This value is found from DSC under nitrogen atmosphere with the heating rate of 5°C/min. The exothermic peak gives a measure of the heat liberated during chemical reaction between epoxy and hardener. In the second run, peak is not appeared, which indicate the completion of curing after 1st run.

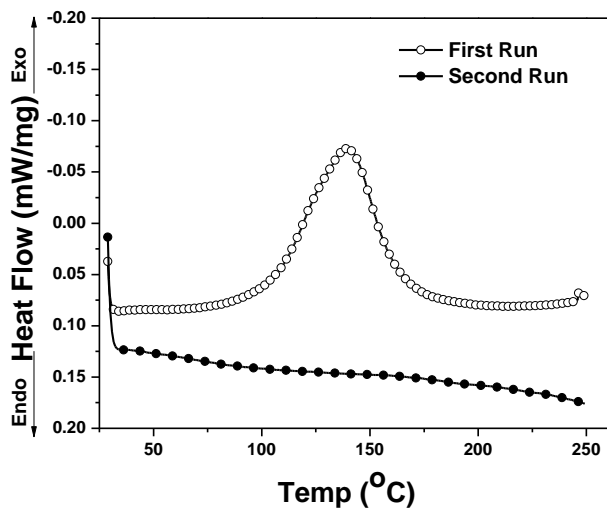
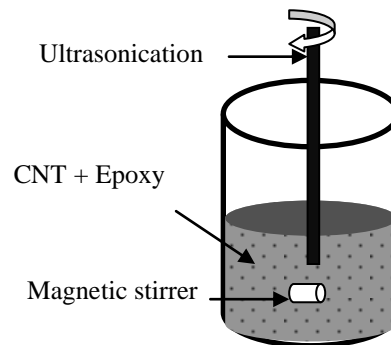


Fig 2.DSC analysis of epoxy resin

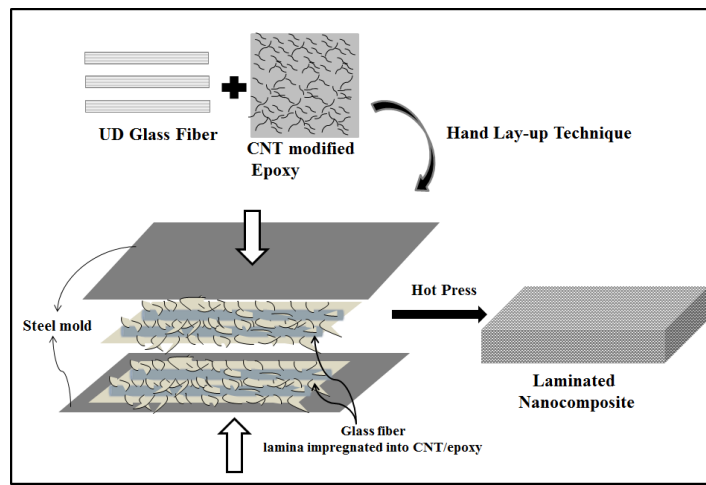
*Step 3: Lamination and Curing*

Fig 3 shows the schematic of the preparation of glass fiber reinforced CNT modified epoxy composite. Two different material configurations designated as GF<sub>E</sub> and GF<sub>CE</sub> were considered. Details of material configuration are shown in Table 1. Material GF<sub>E</sub> is made of epoxy resin and glass fiber, whereas, material GF<sub>CE</sub> is made of CNT-epoxy resin mixture and glass fiber with classical processing. The hand lay-up technique was used for the preparation of laminated composite. The epoxy resin and the curing agent were taken in the ratio of 10:9 by wt% in a beaker and mixed thoroughly until a clear homogeneous viscous

liquid was obtained. Four layers of fabric were impregnated with epoxy resin and placed in a mold. The laminates were fabricated by using conventional compression molding at a constant pressure of 10 kg/cm<sup>2</sup>. The mold was kept under a pressure for 4 hrs at 80°C to obtain a cured laminate. The cured sample was removed from the mold and placed in an oven for 8 hrs at 160°C for post curing. Three specimens of each series were prepared.



Step-1



Step-2

Fig3.Schematic of the processing of glass fiber reinforced CNT modified epoxy composite.

Designation	Materials
GF <sub>E</sub>	Glass fiber reinforced epoxy composite
GF <sub>CE</sub>	Glass fiber reinforced CNT-epoxy composite

Table 1.The details of the materials configuration

*C. Characterization of carbon nanotubes and their composites*

Scanning Electron Microscopy (SEM): The surface morphology of glass fiber, MWCNTs and fractured composite samples were investigated using SEM. The samples were coated with a thin layer of gold to reduce charging during analysis.

Dynamic Mechanical Analysis (DMA): The thermo-mechanical behavior of composite specimens was investigated using a dynamic mechanical analyzer (DMA Pyris Diamond) in the bending mode. Rectangular specimens (50 x 15 x 2mm) were subjected to load-controlled sinusoidal loading (peak load: 5N, frequency: 1Hz, span length: 50 mm) at a heating rate of 3°C/min in the temperature range from 25- 250°C.

Mechanical Test: To investigate the mechanical behavior, tensile tests were performed for all the materials using molded samples per the ASTM/D638-03 type I standard. Straight laminated samples (length: 200 mm, width: 20 mm) were cut from the plate using an automatic diamond saw. All tests were performed using an Instron 8252 universal testing machine with an extension rate of 1 mm/min.

### III. RESULTS AND DISCUSSION

The storage modulus ( $E'$ ) of  $GF_E$  and  $GF_{CE}$  are presented in Fig4. In this Figure, it has been observed that the  $GF_E$  shows a lower storage modulus than  $GF_{CE}$  over the entire range of temperatures i.e., 30 to 250°C. The storage modulus of  $GF_{CE}$  material at 30°C is 24.4 GPa, whereas the  $E'$  values at 30°C for  $GF_E$  is 17.8GPa. Clearly at the room temperature the  $E'$  value of  $GF_{CE}$  sample is enhanced by more than 37% when compared to the  $GF_E$  sample. The modulus is increased due to the high modulus of CNT. Besides this the improvement is also due to the good interaction between the CNT and glass fiber; CNT and matrix; and glass fiber and matrix.

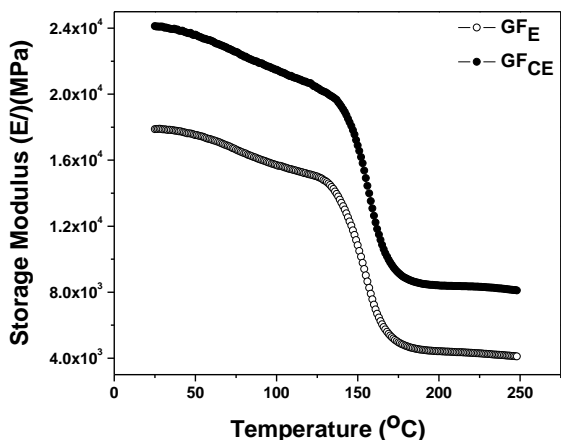


Fig4. Storage modulus of glass fiber epoxy laminated composites with and without MWCNTs

Fig5.presents the  $Tan \delta$  curves of  $GF_E$  and  $GF_{CE}$  material. It has been observed that the  $Tan \delta$  of the  $GF_{CE}$  is decreased, when these are compared with the  $GF_E$  material. From the  $Tan \delta$  vs temperature curves, the values of glass transition temperature ( $T_g$ ) of the  $GF_{CE}$  is observed at 166.7, whereas the values of  $T_g$  of

the glass-epoxy is observed at 156°C. The  $T_g$  are shifted to the higher temperatures in presence of CNTs, because, the movement of epoxy backbone is restricted by CNT and glass fiber. In Fig 5, the  $Tan \delta$  values of  $GF_E$  and  $GF_{CE}$  material at the  $T_g$  are 0.0708 and 0.0613, respectively. This lower  $Tan \delta$  values for  $GF_{CE}$  is attributed to the reduction of mobility of the epoxy chains near the glass fiber surface and carbon nanotubes.

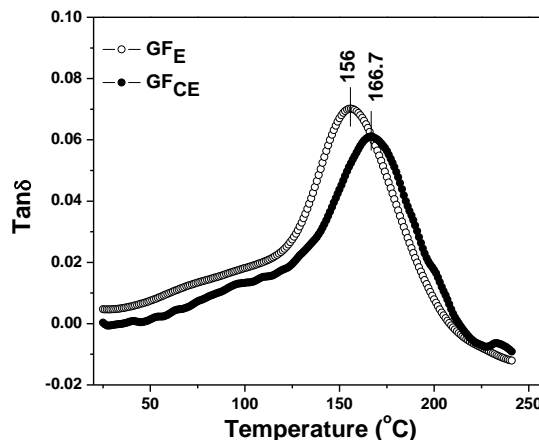


Fig 5.  $Tan \delta$  of glass fiber epoxy laminated composites with and without MWCNTs

Fig5 shows the stress-strain responses from monotonic tensile tests conducted on the  $GF_E$  and  $GF_{CE}$  material. The elastic modulus of the composites was evaluated from the initial slope (0.1% strain) of the stress-strain curves of the specimens. The elastic modulus of  $GF_{CE}$  sample is higher than that of  $GF_E$  sample. The tensile modulus of the  $GF_E$  was 14.6GPa. This value is increased by 30% to 19.2GPa for laminates containing 1.0 wt% MWCNTs. The modulus is increased due to the high modulus of MWCNT. In addition to this the improvement is also due to the good interaction between the CNT and matrix and glass fiber and matrix.

From the tensile test results as shown in Fig 6, we obtained similar conclusions despite modulus improvements were smaller than for the DMA results (see Table 2). The displacement levels up to  $2.3 \times 10^{-3}$  m was used in simple tensile test to evaluate Young's modulus, whereas displacement amplitude used in DMA test was 10-8m. It has been confirmed that this divergence is due to the large difference in displacement levels used in simple tensile test in comparison with the DMA test.

Material	$E'/(GPa)(30^{\circ}C)$	$Tan \delta$	$T_g(oC)$	$E(\text{tensile test})(GPa)$
$GF_E$	17.8	0.0708	156	14.6
$GF_{CE}$	24.4	0.0613	166.7	19.2

Table 2. Storage modulus at room temperature, peak value of  $Tan \delta$ , glass transition temperatures and Young's modulus for the  $GF_E$  and  $GF_{CE}$  material.

The SEM of the fractured surfaces of the glass fiber reinforced CNT-epoxy composite has been done to investigate the CNT-



epoxy interaction and the micro structural changes involved on the incorporation of the CNT into the epoxy matrix. From the micrograph of the fractured surface of the GF<sub>E</sub> specimen (Fig 7(a)), it has been observed that the fracture is ductile in nature. There is smoothness in the fractured surface with very little ruggedness.

The SEM micrographs of the GF<sub>CE</sub> composite reveal that CNTs have the good contact with the glass fiber and matrix, which shows a good interaction among CNTs/epoxy matrix (Fig7 (b)). With introducing CNTs content there is a remarkable difference in the surface morphology of the fractured surface. The smoothness of the fractured surface goes on decreasing in presence of CNTs suggesting a ductile to brittle transformation in the composite material

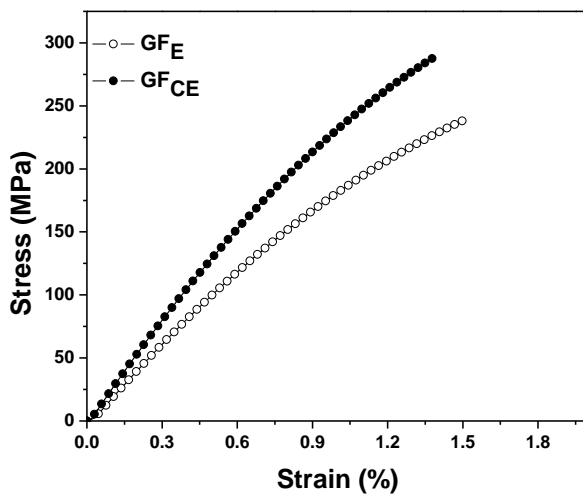


Fig. 6. Tensile stress-strain curves for glass fiber epoxy laminated composites with and without MWCNTs

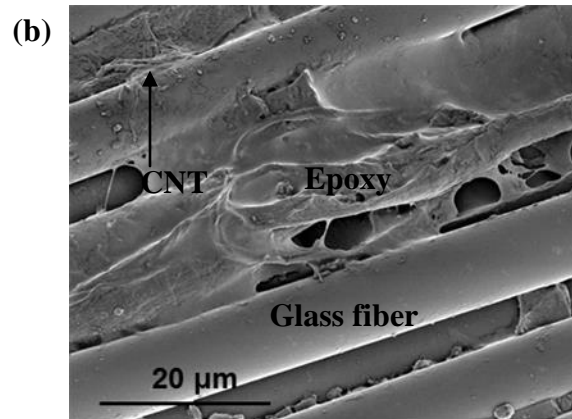
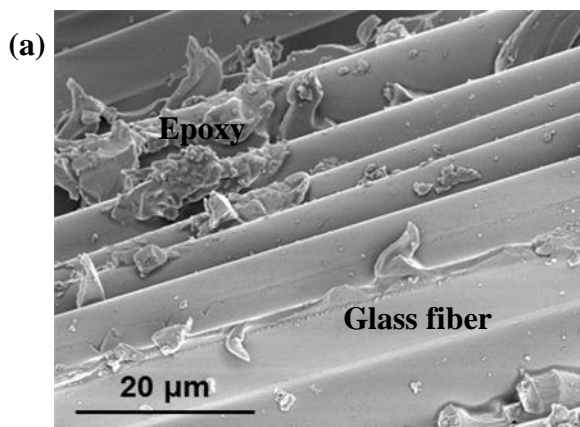


Fig 7. SEM micrographs of fractured samples (a) GF<sub>E</sub> and (b) GF<sub>CE</sub> material

#### IV. CONCLUSION

The influence of CNTs in laminates has been studied using DMA and mechanical testing, etc. The dynamic properties of laminated composites reveal that the E' value of GF<sub>CE</sub> sample is enhanced by more than 38% when compared to the GF<sub>E</sub> sample. The young's modulus and storage modulus of the GF<sub>CE</sub> sample is enhanced due to the presence of CNTs and CNTs-epoxy and CNTs-glass fiber interaction. The T<sub>g</sub> for GF<sub>CE</sub> is shifted to the higher temperatures, because the movement of epoxy backbone is restricted by CNTs and glass fiber.

#### REFERENCES

- [1] Pirvu A, Gardner D.J, Lopez-Anido R. Carbon fiber-vinyl ester composite reinforcement of wood using the VARTM/SCRIMP fabrication process. *Composites: Part A* 2004; 35:1257-1265.
- [2] Rahaman. A, Kar.K.K. Carbon nanomaterials grown on E-glass fibers and their application in Composite. *Composite Science & Technology* 2014; 101: 1-10.
- [3] Thostenson E, Chou T. Processing-structure-multi-functional property relationship in carbon nanotube/epoxy composites. *Carbon* 2006; 44: 3022-29.
- [4] Martone A, Formicola C, Giordano M, Zarrelli M. Reinforcement efficiency of multi-walled carbon nanotube/epoxy nano composites. *Compos.Sci. Technol.* 2010; 70:1154-60.
- [5] Song YS, Youn JR. Influence of dispersion states of carbon nanotubes on physical properties of epoxy nanocomposites. *Carbon* 2005; 43: 1378-85.
- [6] Breton Y, Dresarmot G, Salvat JP, Delpeux S, Sinturel C, Breguin F, Bonnamy S. Mechanical properties of multiwall carbon nanotubes epoxy composites: influence of network morphology. *Carbon* 2012; 42: 1027-30.
- [7] Guo P, Chen X, Gao X, Song H, Shen H. Fabrication and mechanical properties of well-Dispersed multiwalled carbon nanotubes/epoxy composites. *Compos. Sci. Technol.* 2007; 67:3331-37.
- [8] Rahaman A, Kar KK. Effect of coating time and temperature on electroless deposition of cobalt-phosphorous for the growth of carbon nanotubes on the surface of glass fibers/fabric. *Fullerenes, Nanotubes and Carbon Nanostruct.* 2011; 19: 373 – 97.
- [9] Kar KK, Rahaman A, Agnihotri P, Sathiyamoorthy D. Synthesis of carbon nanotubes on the surface of carbon fiber/fabric by catalytic chemical vapor deposition and their characterization. *Fullerenes, Nanotubes and Carbon Nanostruct.* 2009; 17: 209 – 229.

- [10] Agnihotri P, Basu S, Kar KK. Effect of carbon nanotube length and density on the properties of carbon nanotube-coated carbon fiber/polyester composites. *Carbon*. 2011; 49: 3098 – 06.

# Study of Deep Drawing Process Parameters: A Review

Chandra Pal Singh\*, Geeta Agnihotri\*\*

\* Research Scholar, Mechanical Engineering, MANIT BHOPAL

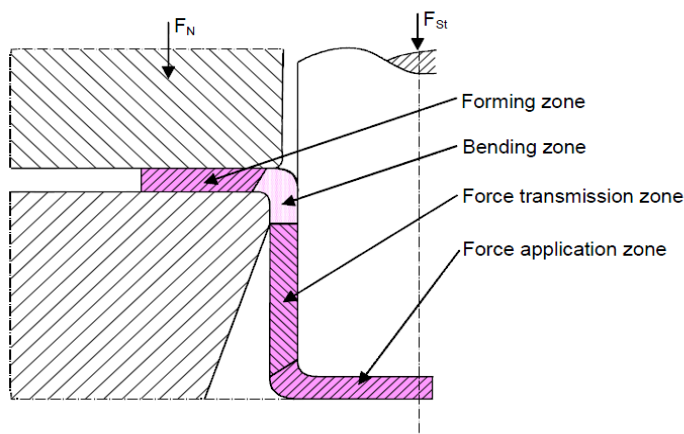
\*\* Professor, Mechanical Engineering, MANIT BHOPAL

**Abstract-** Deep drawing process has been an important manufacturing process to produce automotive parts of good strength and light weight. There are many process parameters and other factors that affect product quality produced by deep drawing. This paper is highlighting recent research work and results in deep drawing. Deep-drawing operations are performed to produce a light weight, high strength, low density, and corrosion resistible product. These requirements will increase tendency of wrinkling and other failure defects in the product. Parameters like as blank-holder pressure, punch radius, die radius, material properties, and coefficient of friction affect deep drawing process. So a great knowledge of process is required to produce product with minimum defects. This review paper has given the attention to gather recent development and research work in the area of deep drawing.

**Index Terms-** Deep Drawing, Blank Holder Pressure, Blank Shape, Friction, Punch Force, Drawing ration, wrinkling

## I. INTRODUCTION

Sheet-metal forming processes are technologically among the most important metalworking processes. Products made by sheet-forming process include a very large variety of different geometrical shapes and sizes, like simple bend to double curvatures even with deep recesses and very complex shapes. Typical examples are automobile bodies, aircraft panels, appliance bodies, kitchen utensils and beverage cans. Sheet-metal forming processes are widely used in the manufacturing industry. It is usually involved in developing and building tools namely die and punch. Usually, tools are costly and the cycle time for building them is long. However, once die and punch are built, the tools can be used to produce a large amount of products. Therefore, sheet-metal forming is a simple and efficient manufacturing process. Great productivity and low production cost can be expected for commercial scale production. As mentioned that the flat sheet of metal is formed into a 3-D product by deep drawing process. The basic tools of the deep drawing process are blank, punch, die and blank holder (or pressure plate). Deep drawing is affected by many factors such as material properties, tool geometry, lubrication etc. Because of these factors, some failures may occur during the process. Tearing, necking, wrinkling, earing and poor surface appearance are the main failure types that can be seen in deep drawing. Tearing and necking are caused by the tensile stresses and they are types of tensile instabilities. Another failure is wrinkling, caused by compressive stresses unlike to tearing and necking. When the radial drawing stress exceeds a certain value compressive stress in the circumferential direction becomes too high, so plastic buckling occurs. The four major defects which can occur during deep drawing are fracture, wrinkling, earing and spring back. The phenomenon of wrinkling (flange instability) is specific to the process of deep-drawing. Instability in the work piece, also



jectives are to obtain defect less or minimum defects in product. wrinkling operation. Because a part wrinkled during the deep drawing factors affect the deep drawing process may be categorized into

iction, drawing ratio, material properties. Geometrical parameters radii of cup. Machine parameters include die radius and punch re stress-strain and anisotropy behaviour of the sheet metal to be anisotropy behaviour in sheet metals, a proper knowledge of the 1.

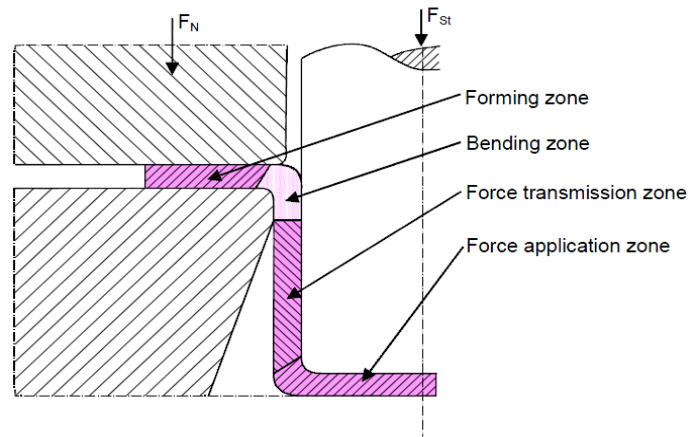


Fig 1: Stress zones in Deep Drawing

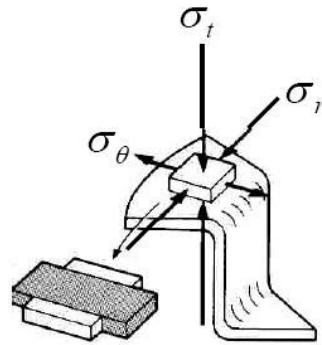


Fig 2: Stress Zone on Element

## 2. Literature Survey

Literature review has been categorized on the basis of the parameters which control forming process, the quantities which decide successful execution of the process and the quality of the product. The important parameters and factors are:

- (i) Blank holder force (BHF) and optimisation BHF.
- (ii) Punch force and punch speed
- (iii) Friction
- (iv) Blank shape
- (v) Forming Limits
- (vi) Stress and Strain Distribution
- (vii) Thickness variation
- (viii) Wrinkling
- (ix) Some other defects

### 2.1 Blank Holder Force (BHF) and Optimization BHF

Higher BHF is always desirable to eliminate wrinkling in deep drawn cup shaped product, but always there have been attempts made to predict a minimum BHF. A lot of research work has been reported to investigate the effect of BHF on product quality, material flow, strain path, stress distribution, thinning (at wall) and thickening (flange) of sheet metal, defects in product. Jaisingh et. al. (2004) has suggested that the blank holder force has the maximum effect on the thinning strain, the coefficient of friction, plastic strain ratio. Also the strain-hardening exponent depends on BHF. Tommerup et. al. (2012) has investigated the effect of blank holder pressure on strain path in the sheet during forming process. A tooling system has been developed to investigate material flow, which is capable of controlling the distribution of blank holder pressure. This tooling system was integral to press and capable to run eight different pressure schemes. The tooling system consisting of a controller to regulate the process parameters, an actuator system to control BHF, a tool with embedded hydraulic cavities. The strain path has been checked by applying variations in the cavity pressures. In this research the drawing of rectangular specimen has been carried out. Van Tung Phan (2012) has simulated the deep drawing process for ferritic stainless steel and investigated the effect of variation of blank-holder pressure and friction on earing profiles. The

simulation results compared with experimental data. Blank holding force and punch speed affect product quality and production rate. Manabe et. al. (2002) has proposed a new combination of punch speed and blank holder fuzzy control for deep drawing process. The control system consists of the fuzzy inference and the database. In this research the investigation of five variables like punch load, punch stroke, maximum apparent thickness (blank-holder displacement), SPD (punch speed) and blank reduction ratio have been recorded. The cup height improvement and the processing time reduction have been chosen as the object functions for evaluation fracture functions. It has been proven that the new combination of SPD and BHF fuzzy control system has improved performance with increased productivity with 25% forming time reduction. Wifi et al. (2007) has presented some aspects of blank-holder force (B.H.F.) schemes in deep drawing process based on finite element assessment. In all models, ABAQUS-Explicit general purpose finite element code has been used with full 3-D capabilities to account for anisotropy of sheet metal and wrinkling of the cups. The blank made of Al 5182 alloy has been used and assumed to be elastic-plastic. Friction has also been considered in simulation using an average overall simple Coulomb friction model with Coefficient of friction = 0.1 between the blank and the tool.

Gharib et. al. (2006) has developed an analytical model for the cup drawing process to calculate the induced stresses and strains over the deforming sheet at any stage of deformation until a full cup is formed. This model has been used as the solution engine for the optimization of the blank holder force for such cups avoiding failure by wrinkling or tearing. The analytical model has been established by considering plastic strains, principal stresses, and von Mises stresses. The results of the incremental analytical model for punch travel vs. punch force, and circumferential strain distributions show good correlation with the experimental results. The present model can be useful in conducting parametric studies on the different parameters which are affecting the process. Volk et. al. (2011) has simulated deep drawing process to investigate, optimized blank holder force (BHF) for an asymmetrical work piece from household appliances industry. In this research work the specific blank holder forces have been identified for minimum wrinkling and for the improve quality product. It has been suggested that the quality of a work piece can be improved with a better holding system. It is evident that even small changes in BHF can lead to failure during the process. These failures can be avoided if a variable BHF is applied, but the correct trajectories need to be chosen.

## 2.2 Punch Force and Punch Speed

Zhao et. al. (2007) has presented hydro-mechanical reverse deep drawing of cylindrical cups with axial pushing effect. The axial pushing force is exerted on the brim of the blank by a pushing ring, this reduces radial tensile stress at the sidewall and the risk of occurring fracture can be reduced considerably. The radial stress at punch-die zone increases with friction and bending, this reduces tangential stresses and thus reduces wrinkling. Also loading capacity of sidewall is enhanced due to strain hardening effect. The finite element simulation for hydro-mechanical reversed deep drawing process has been done successfully with DYNIFORM-PC code combining with modifying load mask keyword manually. The experimental results are in good agreement with the numerical simulation results. Saniee et. al. (2003) has investigated the required drawing force by different methods such as analytical, numerical and experimental techniques. FE simulation has been conducted to study the effect of element type on the forming load and the variation of the thickness strain. The influence of the friction coefficient on the drawing load has also been investigated and maximum drawing force has quantitatively been investigated for both the analytical and FE methods. Among different analytical relationships, Siebel's formula provided the most accurate maximum drawing force for the process under consideration. Browne et.al. (2003) has considered punch and die geometry, blank- holding pressure, top-ram pressure, lubrication, and drawing speed in the deep drawing process and their effects has been studied on 9mm thick CRI steel cups. The optimum parameters for reduced punch loads have been investigated with lubrication by plastic on both sides. The optimum parameters to provide the least variation in wall thickness distribution has also been investigated i.e. optimum ram pressure blank-holding pressure and speed. Atrian Amir et. al. (2013) has investigated the effect of different parameters on deep drawing of laminated sheets. The experimental and finite element studies of the deep drawing process of steel/brass laminated sheets have been performed to show places of tearing for bimetal cup. A linear relation was obtained between the initial blank diameter and the maximum necessary force. Ouakdi et. al. (2012) has investigated the effect of holding force and die radius in a stretch bending test on spring-back. An experimental set up has been developed to find the effect of holding force and die radius on stretching depth. For evaluation, the drawn part has been divided into three critical regions or zones. First zone which is curved takes the shape of cylindrical stretching rod. Second zone subjected to thickness variation which is slightly curved due to residual stresses. Third zone is highly deformed by the stretching effort and bending due to the entrance curvature of the die. The results show that an increase in blank holder force reduces sliding of the sheet between the die and the blank holder and reduces spring-back by increasing the tension. It has also been observed that the greater the entrance radius of the die, the smaller the final spring-back and spring-back decreases in a non-linear fashion with stretching height. The evaluation of spring-back by the stretching height is in agreement with that by the angular orientation of the extremity. Kakandikar et. al. (2005) has used genetic algorithm to optimise the process and geometry parameters for mild steel cup. In this research failure limit diagrams have been plotted to study and compare the formability analysis of the geometries. Finite element analysis simulation software has been used for the



validations of the results after optimization. The results have been analysed in the form of failure diagrams of original geometries with considered failure points and failure diagrams for optimised geometries with no failure points.

### 2.3 Friction

Friction is another important factor that influences deep drawing process. Surface quality of finished product, tool life and drawability of sheet are well dependent on presence of good lubricating film between contact surfaces. In metal forming processes friction influences the strain distribution at tool blank interface and drawability of metal sheet. Also drawability of metal sheet affects wear of tool. Yang (2010) has simulated the deep drawing process to analyze friction coefficient and strain distribution by combining an elastic-plastic FEM code with a friction model. Numerical results are in accordance with the experimental results for the film thickness and the strain distribution. Liu Qiqian et. al. (2012) has simulated micro multi point forming process with cushion. A finite element model with the effect of size has been developed to simulate micro multi point forming process. This research dealt with the effect of parameters like effect of cushion material, cushion thickness, coefficient of friction on the thickness variation and surface finish of the product. In this research results show non-uniform relative thickness distribution from centre to the edge in the deformed sheets. Also it has been found friction affects relative thickness distribution and surface quality in micro multi point forming process. Colgan Mark et. al. (2003) has studied influencing factors like the punch and die radii, the punch velocity, clamping force, friction and draw depth. Experimentally effect of various parameters has been observed then statistical analysis has been performed. The statistical treatment ANOVA has been applied to the results of the experiment to determine the percent contribution of each factor. Study of the ANOVA table for a given analysis helps to determine which of the factors need control and which do not. It has been observed that the punch/die radii have the greatest effect on the thickness of the deformed mild steel cups compared to blank-holder force or friction. It has been observed that smaller is the punch/die radii, greater is the punch force and shorter is the final draw. It has also been observed that if the blank-holder force is not kept within the upper and lower limit of reasonable range, it does have a significant effect on depth of draw. Also tearing of cup through the bottom may occur if the force is too high and if too low wrinkling of the flange area may be occurred. Allen et. al. (2008) has developed experimental set up to determine the effect of lubrication on expansion of die ring during deep drawing of axis-symmetric steel cup. An experimental set up was developed to record punch force and displacement, blank-holder force, and die hoop strain. Different oils were used to provide lubrication between blank and die. The surface finish and wall thickness of the cups produced during the experimental work were measured and evaluated to determine any correlation with the measured die expansion. FEA simulations have been developed for different lubrication conditions and tooling on the process. The experimental results based on die expansion under different lubrication conditions show a difference in the level of die hoop strain. This work also suggest that if lubricating oil film of definite thickness is provided in deep drawing, a expected surface finish could be obtained on final product. FEA models with lubricating oil film thickness can simulate deep drawing more realistic. Yang (2010) has presented elastic-plastic FEM code to simulate deep drawing process with friction model. Numerical analysis has been done to analyze the friction coefficient and the strain distribution in lubricated deep drawing. In this research work the surface roughness is taken into account by using Wilson and Marsault's average Reynolds equation that is appropriated for mixed lubrication with severe asperity contact. In this research the film thickness and strain distribution for various tribological parameters are predicted and compared with the experiment. Numerical results show that the present analysis is in accordance with the experiments for the film thickness and the strain distribution. It has been suggested that the larger value of full film lubrication region results in the more uniform strain distribution. This research work also suggested that when film thickness is greater than composite roughness by three times, the lubrication is full film condition and contact area ratio is almost zero, the contact area ratio near the outer edge of die is about zero and the friction stress is small. The largest value of contact area ratio occurred when the surface asperity of die and blank comes into contact, and it will result in the larger value of friction stress. Generally, lower friction results in a more uniform radial strain distribution. The larger value of full film lubrication region results in the larger value of the low-friction part and the lower value of peak's strain. Thus, an effective lubrication can prevent direct contact of the surface asperity, which enhances the draw-ability of deep drawing. Padmanabhan et. al. (2007) has presented the effect of process parameters such as die radius, blank holder force and friction coefficient on deep drawing of stainless steel. In this research FEM with taguchi technique has been used to determine the proportion of contribution of three important process parameters in the deep-drawing process. Taguchi method of experimental design was used to plan the numerical simulations. In Taguchi design, using two levels of each factors form screening experiments to determine a model of the system to a linear approximation. After designing experiments with various combinations of process parameter levels, FE simulations were carried out to predict the deformation behaviour of the blank sheet. The results obtained from the FE simulations were treated using statistical approach namely, ANOVA method. The purpose of using ANOVA was to find most influential parameters that govern the deep-drawing process that markedly influence the thickness distribution. The analysis of variance (ANOVA) was carried out to examine the influence of process parameters on the quality characteristics (thickness variation) of the circular cup and their percentage contribution. The die radius (89.2%) has major influence on the deep-drawing process,

followed by friction coefficient (6.3%) and blank holder force (4.5%). Hol J. et. al (2012) has studied a friction model that can be used in large-scale FE simulations. The friction model includes two flattening mechanisms to determine the real area of contact at a microscopic level. The real area of contact is used to determine the influence of ploughing and adhesion effects between contacting asperities on the coefficient of friction. A statistical approach is adapted to translate the microscopic models to a macroscopic level. Results of the simulations have shown reasonable values for the coefficient of friction in the case of normal loading only, namely between 0.13 and 0.145. If flattening due to stretching is also incorporated, more realistic values are achieved (between 0.13 and 0.19). Karupannasamy (2012) has investigated deep drawing process for different lubrication conditions considering the micro-mechanisms. Instead of constant friction given by columns friction law, local coefficient of friction is considered to predict coefficient of friction more accurately. Zhenyu Hu (2011) has investigated the application of size dependent friction function into FEM to optimise shape of micro rectangular flange free parts. This research has been focused to investigate the application of friction model of circular parts for the deep drawing of rectangular parts. Topological effects i.e. effect of friction on size of parts to be drawn has also been investigated with simulated friction model. From this research it has been found that simulated friction model for circular parts are valid for rectangular deep drawn parts. Hassan et. al. (2003) has proposed friction aided deep drawing using eight segmented metal blank to improve the defects of Maslennikov process. In Maslennikov process, the elastomer is ring used as pressure medium, the ring is loaded through die to deform the blank material plastically. Maslennikov process has limitation due to small deformation resistance and short life of elastomer ring. The eight segments can move radially in and outward at different blank holder force at constant speed. Due to compressive nature at non slip point, the area of contact increased compared to Maslennikov process and fracture does not occurred. Cups of drawing ratio of 4.0 and height of 91 mm obtained successfully with new process. To investigate proposed deep drawing process experiments have been carried out using soft aluminium sheets of 0.5 and 1.0 mm in thickness. With the new proposed process drawability has increased as coefficient of friction increases. Hassan et. al. (2003) has introduced friction aided deep drawing process by segmented blank holder into four parts. The deformation has been obtained mainly by friction force between blank and blank holder i.e. at the flange. It has been observed that new process provides higher drawing ratio and it has overcome the short comings of Maslennikov's process. Cups with higher drawing ratio i.e. 3.8 and 5.5 have been produced with heights 48 mm and 75 mm respectively. It has been concluded that the process is suitable for low grade steel. Friction aided deep drawing process with segmented blank holder divided in four tapered segments has been investigated by Hassan et. al.(2005). In this study blank holder is having moving and stationary layers. The four moving segments capable of moving radially with uniform speed will have friction force with stationary part and this friction force is used to draw sheet metal. This study has concluded that parts can be produce efficiently with drawing ratio 3.76 with no localized wrinkling. Kim et. al. (2012) has studied coefficient of friction for non uniform pressure by conducting draw bend tests. Tested coefficients of friction are used in FE code for local contact conditions such as the sliding speed, contact pressure and sliding direction at the macroscopic level. Validation of the results has been done by the circular cup drawing experiments and simulations. In this research the contact pressure maps were developed from simulations, which has been included in the analysis of test data to measure the pressure dependency of friction coefficient. Hao et. al. (1999) has developed friction measurement apparatus for sheet metal forming. Friction tests conducted has shown that coefficient of friction increases with increasing test specimen strain, increases with increasing local contact pressure, decreases with increasing stretching speed, i.e. strain rate, and decreases with increasing pin radius. Kim et al (2007) has considered various factors such as punch force, blank holder force (BHF), draw-in length, perimeter of flange after test, change of surface roughness, and surface topography to evaluate the performance of different lubricants. In deep drawing friction is very important factor and flange area is most affected by friction. Due to severe friction there may be thinning or failure of the side wall in drawn cup at the flange area. According to Coulomb's law as the blank holder pressure increases, the frictional stress also increases, so therefore by determining the maximum applicable BHF without failure in the cup wall performance of lubricants may be evaluated. The coefficient of friction for each lubricant tested has determined through the FE-based inverse analysis by matching the predicted and measured values of the load-stroke curve and the draw-in length. Friction coefficients of the lubricants have been implemented in FE codes to get maximum punch force.

## 2.4 Blank Shape

To minimize the process defects and optimize the process, knowledge of the process and material variables are required. Blank shape is one of the important parameter in deep drawing process as the quality of deep drawn product, thickness distribution, forming limits, minimizing the defects can be improved by having optimum blank shape, also material cost of product reduced if proper blank shape is selected. Molotnikov et. al.(2012) has investigated the size effect on maximum load and limit drawing ratio for deep drawing of copper. Numerical analysis and experimental analysis have been done to study the effect of ratio of blank thickness to grain size on blank thickness. Through mathematical modelling and experimental work it has been suggested that size effect play an important role in deep drawing when grain size kept constant and dimensions of work-piece get reduced. This research has suggested the dislocation density based model to take into account for the effect of the specimen dimensions on its mechanical response. Dongkai Xu (2012) et.

al. has proposed a topology optimization method based on Solid Isotropic Microstructure with Penalty (SIMP) to reduce the weight of key die components. To optimize die structure local load mapping has been done which interact with SIMP-based topology optimization method. This gives an idea about forces acting on tooling faces as the blank holder force and different interaction forces affect blank holder structure and these forces will have effect on tooling or die components. In this research the blank holder weight is optimized i.e. blank holder is redesigned and machine through topology optimization, based on optimization results. Optimized blank holder is tested and stamping results are recorded. Results show that the blank holder weight is reduced by 28.1% and defect free stamping parts are formed, also the thickness difference between the original and newly stamped parts along a cross section is less than 0.06 mm, i.e. 4.29% of the initial blank thickness. Fazil et. al. (2012) has proposed iteration based algorithm to optimize blank shape. In the proposed algorithm the process modelled with initial blank shape. The required contours compared with contours obtained at the end of deformation. The deviation of the obtained contour from the required contour is measured and blank shape is modified using the blank optimization algorithm and process analyzed again. Repeatedly the process minimizes the deviation at every boundary node. In this proposed methodology the initial blank is optimized based on the shape error and the deformation path length of the boundary nodes. Talic et. al. (2009) has determined an optimum blank shape that has not caused earing. In this research the forming process has been simulated using Abacus CAE. Blank shape influences forming load, material requirement and possibility of defects. It has been concluded that optimum blank shape reduces forming load, increases forming limits and reduces possibilities of wrinkling and tearing. Lang et. al. (2009) has simulated hydro-forming process using LS-DYNA3D to determined optimized blank shape and the effect of punch pressure. The simulated results have been validated experimentally on a 550-ton double-action sheet hydro-forming press. Aluminium alloy 2B06 (China brand) has been used with thickness 1.5mm. The results show that, pressure curve is quit close to optimized one.

## 2.5 Forming Limits

LDR is the maximum drawing obtained in deep drawing process, it is limited by thickening at flange. The flange portion subjected to radial tensile load and circumferential compressive load. Circumferential load causes flange thickness to be increased. At cylindrical portion biaxial tensile loads act causing blank thinning of sheet. Similarly due to biaxial loading at sheet and tool interface causing a danger of fracture at the interface. BHF can control thickening at flange portion and thinning at blank – tool interface.

Forming limits are one of the important parameter in deep drawing and it is dependent on process parameters. Lot of works have been reported to find forming limits and forming curves. The forming limit of an HDD process is largely dependent on component shape. Kandil Anwar (2003) has presented experimental investigation to find the effect of hydro-forming deep drawing parameters on drawability of different metals. An experimental test rig has been developed to produce symmetric and non-symmetric cups. Wrinkling in case of hydro-forming is very severe failure as compared to conventional deep drawing. During the cup forming process failures occurred and these failures were eliminated by adjusting initial pressure. It has been found that the maximum pressure ranges between 0.15-0.3 of the mean flow stress of sheet metals. LDR has been determined by maximum blank size used to obtained successful drawn cup from each sheet metal. It has been found strain hardening coefficient affects LDR and higher LDRs has been obtained with hydroforming deep drawing as compared to conventional deep drawing due to more uniform strain hardening. Drawing ratio has been found to be the function of the initial pressure in pressure container and so initial pressure inside pressure container plays a significant role in hydro-forming process. Sokolovan et. al. (2012) has studied formability of layered composite. It has been observed that the forming behaviour of the three layered sandwiches is strongly influenced by the geometry of the punch and the core thickness. It has been observed that by increasing the total thickness of a material its resistance to deformation increases. The deep drawing force decreases with an increase of the sandwich core thickness from 0.2 to 1.0 mm. It has been observed that increase in thickness of polymer layer increases inner metallic skin curve radius, this reduces the deformation. Also core thickness of polymer influences formability of metallic outer skins. As there is an increase in core thickness, metal draws easily. For the deep drawing with a circular punch the failure observed for sandwiches with core thicknesses between 0.2 and 1.6 mm in the cup head/edge region, whereas samples with a core thickness of 2.0 mm showed no failure by cracking. For all thickness combinations some wrinkling in the flange region of sandwiches has been observed. Ali (2012) has used analytical method for estimating the limiting drawing ratio (LDR) for drawing process and investigate the effect of drawing parameters such as coefficient of friction, strain hardening exponent, normal plastic anisotropy ratio, ratio of die arc to blank thickness and blank thickness to diameter on LDR. Banabic et.al. (2013) has experimentally determined the Forming Limit Curves (FLCs), representing the whole strain range specific to the sheet metal forming processes. Signorelli et. al. (2012) has investigated crystallographic texture effect on forming limit of an electro-galvanized steel sheet. Forming limit curves are representation of maximum strain as function of major and minor strain in the sheet plane that a material can sustain without failure. The anisotropy effect on the FLC has been evaluated using hourglass-type samples taken at 00, 450 and 900 with respect to the sheet rolling direction. In this research the influence of plastic anisotropy on FLD has been determined experimentally and numerically for a cold-rolled and annealed, electro-galvanized, DQ-type steel sheet. Predictions have been made

with viscoplastic polycrystalline models. It has been concluded that the crystallographic texture of the zinc coating can affect the friction at the sheet-tool interface and, therefore, influences sheet-forming behaviour. Wu et. al. (2004) has simulated hydro-mechanical deep drawing of stepped components for determination of upper and lower forming limits using ABAQUS/ Explicit. FE simulation results are compared with reported experimental results. Comparison shows good agreement and it has been proposed, that FE analysis may be used to derive “master curves” of HDD. The results of FE simulations of the HDD of components with stepped geometries suggest that FE analysis may be used as an efficient tool to determine upper and low forming limits that refer, respectively, to the initiation of rapture and wrinkling of the sheet metal. Wan et. al. (2001) has determined limiting drawing coefficient for conical cups. The drawing coefficient for conical cups has been determined by mechanical analysis and combination of internal relation between cylindrical cup and conical cup. Results obtained from theoretical relations have been checked by experimental results. The limit deformation of conical cup drawing has been expressed by limiting drawing coefficient, the smaller is the limiting drawing coefficient the larger the limit deformation and vice-versa. This work also give equation to determine practical limiting drawing coefficient of conical cup and corresponding charts concerning forming limit curves and limiting drawing coefficient during first deep drawing. Thiruvarudchelvan et. al. (2007) has conducted experimental work for hydraulic-pressure assisted deep drawing process. The experimental test results have yielded data relating to pressure and blank holding force variations with punch stroke for drawing cups up to a draw ratio of 2.77. In hydraulic pressure assisted drawing process the drawing stresses are reduced by pushing effect of hydraulic pressure. In this research work it has been observed that if the counter hydraulic pressure is maintained at some optimum level, the full strength of the cup wall at the die throat can be utilized. Also increased pressure helps to take advantage of the increased flow stress of the strain-hardened cup-wall. Robert et. al. (2012) has proposed incremental deformation theory and compared it with the flow rule of plasticity. In both theories material non linearity has been taken into account by considering elasto- plastic formulation with anisotropic plasticity criterion. The process has been simulated using commercial FE code ABAQUS EXPLICIT. To test CPU time in both theories first a stretch forming of a spherical cup has been considered in which the contact conditions between the tools and the sheet are dominant and in second case the single point incremental forming of a cylindrical cup has been considered in which the localized contact zone between the tools and the sheet is following the tool path all along the forming operation. It has been observed that in first case CPU time reduced to 70% and in second case only 4% reduction achieved. It has been concluded that the new algorithm gives best result when the material non-linearities are dominant. Jayahari et. al. (2014) has investigated formability of austenitic stainless steel at higher temperatures. It has been observed that at higher temperature the limiting drawing has been increased and LDR up to 2.5 could be achieved. The improvement in LDR has been observed up to 3000C. It has also been observed that at warm conditions friction decreases and amount of residual stresses also get reduced which results in better quality of product. Al alloy has also been investigated and at warm condition Al alloy also showed improved drawability.

## 2.6 Stress and Strain Distribution

Assempour Ahmad et. al. (2011) has studied the effect of normal stress on hydrodynamic deep drawing process. Analytical model has been developed by considering classical theory of plasticity and geometrical relationships. In this study the influence of normal stress on the variation of blank thickness, stress and strain fields and punch force has been studied. The differences have been observed in thickness distribution, in stress and strain in both radial and circumferential direction and also in punch force with and without the normal stress. Higher thickness has been observed in the 2D stress state than in the 3D stress state. Also higher values of radial and circumferential strain have been observed in case of normal stress. This article suggests normal stress component should be considered in the deformation of HDD process to achieve accuracy in design. In deep drawing process strain path varies with variation in process parameters. To achieve successful deep drawing process, amount of strains and strain path has to be controlled. Thuillier et. al. (2010) has simulated deep drawing to predict the strain path change for the punch force. In this research Hill’s yield criterion has been used to perform three-dimensional numerical simulations of the process. Different hardening laws have been used to simulate process in different ways. In this research work evaluation of punch force has been done to predict change in strain path in redrawing. Strain hardening models take into account transient behaviours recorded during strain path changes. Jaisingh Amit et. al. (2004) has done sensitivity analysis of four parameters like strain hardening exponent, plastic strain ratio, coefficient of friction, blank holding force for deep drawing process on the basis of peak thinning strain developed as the main parameter. In this research plain strain analysis of bell shaped geometry has been done using Taguchi’s robust design technique. This research has investigated the effect of all the four parameter on the thinning of metal sheet. This research has suggested that the blank holding force has maximum effect on thinning strain. Other parameters i.e. coefficient of friction, plastic strain ratio, strain hardening exponent follows the blank holding force. Tabourot et. al. (2005) has investigated hardening curve (determined by image analysis) and strain localisation with FEM simulation for deep drawing of steel sheets. In this research the proposed numerical criterion of detection of the localisation of strain consists in counting the unloaded elements during numerical simulation from a post-processing program. This criterion applied to simulate a deep-drawing operation of an isotropic material. This enabled not only to give precisely the load applied to the tooling

during the shaping operation but also to correctly determine the onset of the localisation within the part. Cwiekala, et. al. (2011) has proposed a method, which combines different analytical approaches to an accurate and fast deep drawing simulation. The developed simulation method is applicable to axisymmetric and prismatic deep drawing processes. Consideration of material behaviour, process parameters and deformation paths is possible in the proposed method. Due to the multistep simulation, even time dependent effects can be considered. The developed method gives a higher accuracy in calculating strain distributions than numerical one step solvers. A computation speed of the proposed method is 80 times faster for axisymmetric parts and for prismatic parts 20 times faster than numerical one step solvers. Besdo (2012) has studied a method for spring back phenomenon, which combines Taylor's and Sachs' theories of deformation. Taylor assumed that the deformation of all grains is uniform and Sachs assumed that the stresses are identical. Taylor's theory yields upper bounds for the inner power; Sachs' theory with its simplified statics leads to lower bounds. So combination of these two can produce good results. Spring back is very complicated phenomenon especially when the influence of bending processes is dominant. In such cases a bending and a subsequent re-bending process followed by a complete un-loading makes complicated material behaviour. The curvatures in bending and subsequent re-bending depend strongly on the elastic-plastic transitional behaviour. So therefore to study plastic deformation more descriptive material properties are required in elastic-plastic transition. Bagherzadeh et. al. (2012) has developed analytical models to investigate stress analysis and instability condition in hydro-mechanical deep drawing (HMDD) of cylindrical AL/St cups. These analytical models have been verified experimentally and could predict fluid pressure for HMDD process with reasonable accuracy. It has been observed that the critical fluid pressure is affected by layer thickness, drawing ratio and friction condition.

## 2.7 Thickness variation

In deep drawing the sheet metal thickness vary throughout the process. Thickness variation depends on process parameters. Several research works have been reported to evaluate thickness variation. Claudio et. al. (2006) has simulated deep drawing process for steel sheets to predict values of maximum punch force, in-plane principle deformation and thickness distribution in the sheet. The performance of model has been assessed by Erichsen test and the deep drawing of a cylindrical cup. Experimental validation of numerical prediction has been achieved for punch force, final value for the in-plane deformations and thickness distributions on the sheet. The model than has been applied to simulate industrial sheet metal forming process consisting of the deep drawing of a component of a commercial washing machine. Maximum punch force, in-plane deformation and thickness distribution predicted numerically have been in agreement with experimental values. Brabie et.al. (2013) has investigated the thickness variation in the case of micro/milli- cylindrical drawn cups made from sheets, called foils, having thicknesses from 0.05 to 0.20 mm. A mathematical model has been proposed based on experimental and numerical simulation results to control and minimise the thickness variation in the part wall where the variations of part diameter, wall inclination and wall curvature can generate negative effects. Natarajan et. al. (2002) has simulated deep drawing of circular blanks consider the axis-symmetric component using finite element techniques. A rigid plastic material model with the variation approaches are used in the finite element analysis. Amount of draw and flange thickness variation have been determined numerically and verified experimentally, for this the circumferential and radial strains have been calculated. Aluminium 1100-O grade material has been taken to analyse hemisphere cup drawing. Singh et. al. (2008) has investigated effect of process parameters on product surface finish and thickness variation in hydro-mechanical deep drawing process. In this research the effect of process parameters like pre-bulge pressure, cut off pressure and oil gap in hydro forming process are investigated. An Experimental set up has been developed for cylindrical cup drawing from flat circular blank by hydro-mechanical deep drawing process. The results have shown that pre-bulging pressure affected the cup quality in terms of thickness distribution and surface finish. It has been observed that there is a region where uniform thickness distribution and better quality surface obtained during drawing process. Also it has been observed that in hydro-mechanical deep drawing more uniform thickness obtained along the cup wall as compared to conventional deep drawing. Peled et. al. (2004) has used Cosserat theory of a generalized membrane to evaluate thickening of the blank including strain rate and strain hardening. The Cosserat theory of a generalized membrane has been used to obtain a transient nonlinear analytical solution for the rigid-plastic flow of the blank in a hydro-forming process. During the deep drawing process due to circumferential stresses there is always some thickening at the flange and to simulate deep drawing process this feature should be considered. The proposed analytical approach has the capability to calculate rate of thickening of the blank, the current radius, the current stress applied at blank holder and the current punch load. Thiruvrarduchelvan et. al. (1998) has carried out theoretical analysis, finite element analysis and experimental work to determine correlation between the forming parameters of the process and to determine the mechanics of the process. The process has been simulated using the commercial FEM code MARC considering elastic-plastic behaviour. The Experimental work has been conducted using the tooling assembled on a 200 ton press. This investigation has suggested that the wall thickness is quite uniform except for the area near the punch nose radius when drawing cups at the three draw ratios 3.0, 3.3 and 3.5. This research suggests as drawing ratio increases thinning increases. Intarakumthornchai et. al. (2010) has studied the deep drawing process to minimise part thinning without crack and wrinkle. 2D



interval halving and response surface methods have been used for the analysis of process parameters for hydro mechanical deep drawing of a parabolic cup. A nonlinear dynamic explicit code, LS-DYNA has been used for the analysis considering a friction coefficient of 0.12 between the blank and the punch. This research suggests that response surface method (RSM) could predict the optimal blank holder force and linear pressure profiles for hydro mechanical deep drawing of the parabolic cup. Dao et. al. (2011) has investigated effect of process parameters on thickness distribution of trapezoid cup. In this research, the optimum values of process parameters like punch speed, chamber pressure and coefficient of friction has been investigated using FEM and Taguchi method.

## 2.8 Wrinkling

Wrinkling is one of most severe defect in deep drawn product. Wrinkling may be defined as the formation of waves on the surface to minimise the compression stresses. There are two regions where wrinkling may take place first one is flange and second one is cup wall. Wrinkling on flange may be minimised by having optimum blank holder pressure but wrinkling on side walls cannot be prevented by any single parameters, so different parameters need to be set to minimise side wall wrinkling. Methods reported in literature to prevent side wrinkling are bifurcation method and energy method. In bifurcation method total wrinkling energy at the middle surface is taken as sum of bending energy, twisting energy, strain energy and work-done by in-plane stresses. Higher BHF is always desirable to eliminate wrinkling in deep drawing of cup shaped product, but always attempts have been made to predict a minimum BHF. Kadkhodayan et. al. (2011) has studied flange wrinkling in deep drawing process. In this research an analytical approach is used to study plastic wrinkling of flange in deep drawing by using bifurcation and Tresca yield criterion. The proposed analytical approach predicts more exact results for large width flange and explains effect of blank holder pressure on wrinkling. Morovvati et. al.(2010) has studied wrinkling phenomenon using theoretical, FE simulation, experimental methods for two layer sheets (aluminium-stainless). A 2D analytical model based on energy method has been developed for two layered sheet. In this model circumferential and radial stresses have been taken into account and thickness stresses has been ignored. This study shows the effect of parameters related to two-layer sheets such as lay-up and mechanical properties of each layer on wrinkling. The results suggested that for a given blank diameter, increase in punch diameter tends to decrease in the BHF and for a given punch diameter, increase in blank diameter decreases the BHF. The minimum required BHF to prevent wrinkling for A.I. lay-ups (when aluminium layer and punch are in contact) is higher than the one for S.I. lay-ups. It has also been observed that required forming load for A.I. lay-up is more than that required for S.I. lay-up. Abbasi et. al. (2012) has analyzed deep drawing of tailor welded blanks and analyzed wrinkling behaviour with thickness ratio greater than one. Experimental results in regard with conical cup wrinkling test are compared with analytical predictions based on bifurcation method. It has been observed that shear stresses are significant when thickness ration greater than one during wrinkling analysis. A good agreement of theoretical analysis and experimental analysis has been reached and it has been concluded that the wrinkling tendency of tailor welded blanks can be evaluated by bifurcation theory. Although a good agreement between the experimental and analytical results has been observed, but due to assumptions made for simplification there might be deviation between predicted results from experimental one. Hassan et. al. (2012) has investigated the effect of bulge shape and height on the wrinkling formation and sheet strength by using finite element method. The results show formation of concentric wrinkles pattern on thin flat sheets which improve part strength. En-zhi gao et. al. (2009) has investigated the effect of material parameters on deep drawing process, using thin-walled hemispheric surface part. A 3D-FE model has been developed for the deep drawing simulation of a thin-walled hemispheric surface part using finite-element code ABAQUS. It has been shown that, the maximum equivalent plastic strain occurs near the wall region outside the die radius. Wrinkle has been observed at this region and flange portion of the part. The results have suggested that, when elastic modulus increases but yield stresses decreases than maximum equivalent plastic strain occurs at wall region outside the die corners. And also when higher punch force occurs, elastic modulus or yield stress increases than yield stress more notable on punch force. These results provide some guidelines for selecting the materials of blank and determining the forming parameters according to the change of materials parameters. The experimental work was conducted on a 500 tonnes hydraulic press. Ayari et. al. (2009) has studied deep drawing process to evaluate the effect of parameters on wrinkling and thickness variations. In this research finite element simulations using ABAQUS/Explicit have been developed for two different material that are aluminium HFS and mild steel. It has been suggested that the coefficient of friction between different contact (Blank – Die, Punch Blank contact etc.) is the very important parameter. Malekani et. al. (2008) has investigated numerically and experimentally the die and blank holder shape to avoid wrinkling in deep drawing of cup. Finite element program code (ANSYS Inc., 2007) has been used to perform the numerical simulation of the deep drawing operation. In this research hoop stress distribution in the flange for different die and blank-holder has been studied for ISO 1624 low carbon steel with the thickness of 1.5mm. It has been observed that by increasing the slopes of die and blank holder up to an optimum amount, wrinkling can be minimised. The optimum amount of slope for die as 6.38 degree has been suggested. In this investigation it has also been observed that as the slope in die and blank holder increases LDR increases. Henriques et. al. (2009) has simulated sheet metal forming process using FEM codes ABAQUS/Standard to determine the description of wrinkling initiation and propagation during sheet metal forming operations. In this

study distinct numerical simulation strategies, based on the Finite Element Method (FEM), have been used for the study of wrinkling initiation and propagation during sheet metal forming operations. Reddy et. al. (2012) has investigated dependency of wrinkling on various parameters like BHF, punch radius, die edge radius, and coefficient of friction in deep drawing process of cylindrical cup. As the wrinkling initiation and growth analysis has been difficult because of wide scattering data for small deviations, but this investigation has suggested some guide lines to minimise wrinkling. It has been concluded that increased blank holding force, reduce friction, large radius at tool edge and reduce deep drawing depth could minimise wrinkling.

## 2.9 Other Defects

Nanu et. al. (2012) has proposed a function that relates springback with process parameters and stress distribution in the sheet metal in the case of U stretch-bending. The proposed model has expressed stress distribution in the sheet as a function of process parameters, tools geometry and material properties, while the springback parameters as a function of stress distribution in the sheet thickness. Based on mathematical model the prediction of springback has been done in deep drawing process. Pereira Michael et. al. (2013) has studies experimentally sheet metal stamping process to examine the wear location, its type and severity that occurs over the die radius. In This research it has been suggested that the wear over the die radius primarily consisted of a combination of ploughing and galling mechanisms. Further it has been suggested that the galling wear mechanism, result in failure of the sheet metal stamping process that takes place over most of the die radius surface, therefore, it is critical to the overall tool wear response. This study has suggested that the overall tool wear response and tool life for the channel forming process is primarily dependent on the transient contact and deformation conditions experienced at the die radius and blank surfaces. Saxena et. al. (2012) has investigated damage behaviour to predict fracture initiation in deep drawing. In this research a parametric study has been proposed to investigate the effect of material, geometric and other process parameters on maximum cup height and to evaluate damage. The damage has been evaluated using the damage growth law proposed by Lemaitre and it has been suggested that Lemaitre model can predict fracture in deep drawing. In this research it has been suggested that the maximum cup height (i.e., the cup height at which the fracture initiates) increases with the sheet thickness, the die profile radius and the punch profile radius. In this study it has been observed that the plastic properties of material affect fracture initiation. In case of square cup fracture initiation is influenced mostly by the plastic deformation in the corner regions and less by the triaxiality. Lou et. al. (2012) has investigated fracture mechanisms to determine fracture forming limits. In this research a new criterion has been proposed considering damage accumulation induced by nucleation, growth and shear coalescence of voids. The equivalent plastic strain, the stress triaxiality, and the normalized maximal shear stress have been taken as function of nucleation, growth and shear coalescence of void to represent a fracture model. In this research fracture forming limit diagram has been suggested for dual phase steel sheets. The fracture model suggested in this research can predict ductile fracture in a stress triaxiality ranging from  $-1/3$  to  $2/3$ . Khelifa et. al. (2008) has presented a model based on anisotropic elasto-plastic and isotropic ductile damage for the prediction of damage in work-piece during stamping or forming of square cup of steel. In this research a coupled approaches have been suggested in which the damage evolution equation is directly incorporated and coupled with the constitutive equations. The results obtained from numerical simulation have been compared with experimental results. The proposed model also predicts the elastic, plastic, and hardening behaviours. Salehinia et. al. (2009) has simulated deep drawing using FE standard code ANSYS 9.0 considering the elasto-plastic behaviour for the blank to predict the relative wear depth. It has been observed that as planner anisotropy does not remain constant the relative wear depth in circumferential direction also changes on the die shoulder. Large anisotropic coefficient is in circumferential direction so less relative wear depth is in circumferential direction. In case of normal anisotropy relative wear depth is constant in circumferential direction. Also it has been observed that as the normal anisotropy index is higher the relative wear on the die shoulder will be higher. Increasing the radius of the die shoulder causes the relative wear depth to be decreased. Ali et. al. (2008) has studied deep drawing process to identify the region of punch stroke within which tear occur. In case of light weight components of complex shapes made of blank material which shows a small operating window, identification of critical tearing region enabled to develop strategy to produce sound parts. This study shows that if blank holder force is applied at an ultra- low frequency and synchronized with the punch force then BHF can be maintained within the process limits for the entire critical width of the critical tearing window and complex shapes may be produced. This research describes experimental investigations in which cylindrical-shaped cups are drawn with a pulsed blank-holder force (PBHF) at ultra-low (less than 1 Hz) and low (1–10 Hz) frequencies. The tests have been conducted with blanks of steel and of aluminium over a range of draw ratios. Tests have been conducted with different blank diameters in the range of 220–250 mm, with frequencies, in the range of 1–10 Hz and amplitudes between 10 and 50 kN.

## 3. Conclusion

This paper has critically reviewed the process parameters and their effect such as blank holding forces, die pressure, punch pressure, effects of friction etc. In this review about eighty two research papers have been critically reviewed for the study of all

affecting process parameters. Blank holder force is one of the important process parameter that needed to be selected very carefully during deep drawing process. Blank holder force controls metal flow, it also affects thickness variation, strain path, stress path and wrinkling behaviour. Strain path is well affected by blank holder pressure. By maintaining an optimum blank holder pressure, precise thickness variation in drawn cup and strain path can be maintained. Blank holding force and punch speed affects product quality and production rate. Blank holder force also controls wrinkling. Blank shape is an important parameter in deep drawing process as the quality of deep drawn product. Blank shape influences forming load, material requirement and possibility of defects. It has been concluded that optimum blank shape reduces forming load, increases forming limits and reduces possibilities of wrinkling and tearing. Forming limits depends on various process parameters such as friction between blank and blank holder. Higher LDRs can be obtained with uniform strain hardening. FE analysis may be used as an efficient tool to determine upper and low forming limits that refer respectively to the initiation of rupture and wrinkling of the sheet metal. Friction is one of the most influential parameter in deep drawing process. Friction affects relative thickness distribution and surface quality in micro multi point forming process. The punch/die radii have the greatest effect on the thickness of the deformed material. If lubricating oil film of definite thickness is provided in deep drawing an expected surface finish could be obtained on final product. An effective lubrication can prevent direct contact of the surface asperity, which enhances the draw-ability of deep drawing. Drawability of metal sheet increases as coefficient of friction increases. Coefficient of friction increases with increasing test specimen strain, increases with increasing local contact pressure, decreases with increasing stretching speed, i.e. strain rate, and decreases with increasing pin radius. In deep drawing process strain path varies with variation in process parameters. To achieve successful deep drawn product, strains and strain path has to be controlled. By considering normal stress component in simulation of deep drawing process more accurate results can be obtained. The blank holding force has maximum effect on thinning strain. Due to blank holder force there will also be thickening of sheet metal at flange. Thickness variation at wall inclination and wall curvature has been very critical. The wall thickness does remain uniform for the area near the punch nose radius and the thinning increases as the draw ratio increases. Wrinkling is one of most severe defect in deep drawing process. By increasing the slopes of die and blank holder up to an optimum amount, wrinkling can be minimized. Increased blank holding force, reduce friction, large radius at tool edge and reduce deep drawing depth could minimize wrinkling. So for successful execution of deep drawing manufacturing process, a deep knowledge of all factors affecting the process is must.

## REFERENCES

1. Abbasi M., Ketabchi M., Labudde T., Pahl U., Bleck W. "New Attempt to Wrinkling Behavior Analysis of Tailor Welded Blanks During the Deep Drawing Process" *Materials and Design*, vol.40, pp 407-414, 2012.
2. Abdalla S. Wifi, Tamer F. Abdelmaguid, Ahmed I. El-Ghandour, "A Review of the Optimization Techniques Applied to the Deep Drawing Process", vol., pp. 1111-1121, 2007.
3. Aboutalebi Farhad Haji, Farzin Mahmoud, Mashayekhi Mohammad, "Numerical Predictions and Experimental Validations of Ductile Damage Evolution in Sheet Metal Forming Processes", *Acta Mechanica Solida Sinica* Published by AMSS Press, Wuhan, China vol. 25, pp 648- 654 , 2012.
4. Ali S., Hinduja S., Atkinson J., Bolt P., Werkhoven R., "The Effect of Ultra-Low Frequency Pulsations on Tearing During Deep Drawing of Cylindrical Cups" *International Journal of Machine Tools & Manufacture*, vol. 48, pp 558-564, 2008.
5. Allen S.J., Mahdavian S.M. "The Effect of Lubrication on Die Expansion During the Deep Drawing of Axisymmetrical Steel Cups", *Journal of Materials Processing Technology*, vol.199, pp 102-107, 2008.
6. Assempour Ahmad, Taghipour Ehsan, "The Effect of Normal Stress on Hydrodynamic Mechanical Deep Drawing" *International Journal of Mechanical Sciences*, vol.53, pp 407-416, 2011.
7. Atrian Amir, Saniee Faramarz Fereshteh, "Deep Drawing Process of Steel/Brass Laminated Sheets Composites" : Part B, vol. 47, pp 75-81 2013.
8. Ayari F., Lazghab T., Bayraktar E., "Parametric Finite Element Analysis of Square Cup Deep Drawing", *Archives of Computational Materials Science and Surface Engineering*, vol.1, Issue No. 2, pp. 106-111, 2009.
9. Bagherzadeh S., Mollaei-Dariani B., Malekzadeh K. "Theoretical Study on Hydro-Mechanical Deep Drawing Process of Bimetallic Sheets and Experimental Observations" *Journal of Materials Processing Technology*, vol. 212, pp 1840-1849, 2012.
10. Banabic D., Lazarescu L., Paraianu L., Ciobanu I., Nicodim I., Comsa D.S., "Development of a New Procedure for the Experimental Determination of the Forming Limit Curves" *CIRP Annals - Manufacturing Technology*, vol. 24, pp 45-52, 2013.

11. Baosheng Liu , Lihui Lang, Yuansong Zeng, Jianguoc Lin, "Forming Characteristic of Sheet Hydroforming Under the Influence of Through-Thickness Normal Stress", *Journal of Material Processing Technology*, vol. 212, pp 1875-1884, 2012.
12. Besdo D. "Material Laws Denoting the Influence of Textures Due to Spring Back Simulations", *Computational Materials Science*, vol.52, pp 82-89, 2012.
13. Brabie G., Costache E.M., Nanu N., Chirita Vasile Alecsandri B., "Prediction and Minimisation of Sheet Thickness Variation During Deep Drawing of Micro/Milli Parts", *International Journal of Mechanical Sciences*, vol.68, pp 277-290, 2013.
14. Browne M.T., Hillery M.T. "Optimising the Variables When Deep-Drawing C.R.1 Cups", *Journal of Materials Processing Technology*, vol. 136, pp 64-71, 2003.
15. Cafuta G., Mole N., Stok B., "An Enhanced Displacement Adjustment Method: Spring-Back and Thinning Compensation", *Journal Material and Design*, vol. 40, pp 476-487, 2012.
16. Chiles V., Black S.C., Lissaman A.J., Martin S.J., "Principles of Engineering Manufacturing", Third Edition, ISBN: 9780080539614, pp 183, 2002.
17. Colgan Mark, Monaghan John, "Deep Drawing Process: Analysis and Experiment", *Journal of Materials Processing Technology*, vol. 132, pp 35-41, 2003.
18. Claudio Garcia, Diego Celentano, Flores Fernando, Ponthot Jean-Philippe, Oliva Omar, "Numerical Modelling and Experimental Validation of Steel Deep Drawing Processes Part – II Application" *Journal of Material Processing Technology*, vol. 172 pp. 461-471, 2006.
19. Cwiekala T., Brosius A., Tekkaya A.E. "Accurate Deep Drawing Simulation by Combining Analytical Approaches, " *International Journal of Mechanical Sciences*, vol.53, pp 374-386, 2011.
20. Dao Thanh-Phong, Huang Shyh-Chour, "Study on Optimization of Process Parameters for Hydro-Mechanical Deep Drawing of Trapezoid Cup", *Journal of Engineering Technology and Education*, vol. 8, Issue No.1, pp. 53-71, 2011.
21. Delameziere Roberta A., Santo P. Dal, Batoz J.L., "Comparison Between Incremental Deformation Theory and Flow Rule to Simulate Sheet-Metal Forming Processes", *Journal of Materials Processing Technology*, vol. 212 pp 1123-1131, 2012.
22. DeSouza T., Rolfe B.F., "Understanding Robustness of Spring-Back in High Strength Steels", *International Journal of Mechanical Science*, vol. 68, pp 236- 245,2013.
23. En-zhi Gao, Hong-wei Li, Hong-chaoKou, Hui Chang, Jin-shan Li, Lian Zhou, "Influences of Material Parameters on Deep Drawing of Thin-walled Hemispheric Surface Part", *Trans. Nonferrous Met. Soc. China*, vol. 19, pp 433-437, 2009.
24. Faris Saad Theeyab, Shihab Suha Karim, "Study and Design the Hydrodynamic Deep Drawing Process for Blanks of Non Uniform Thickness", *Diyala Journal of Engineering Sciences*, Special Issue, pp 40-56, 2010.
25. Gantar G., Kuzman K. and Filipic B., "Increasing the Stability of The Deep Drawing Process by Simulation-Based Optimization", *Achievements of Mechanical and Materials Engineering*, vol.49, pp 243-246, 2005.
26. Gharib H., Wifi A.S., Younan M., Nassef A., "An Analytical Incremental Model for the Analysis of the Cup Drawing", *Journal of Achievements in Materials and Manufacturing Engineering*, vol. 17, pp 245-248, 2006.
27. Gharib H., Wifi A.S., Younan M., Nassef A., "Optimization of the Blank Holder Force in Cup Drawing", *Journal of Achievements in Materials and Manufacturing Engineering*, vol. No. 18, Issue No. 1-2, pp 291-294, 2006.
28. Grobmann K. , Penter L., Hardtmann A., Weber J., Lohse H., "FEA of Deep Drawing with Dynamic Interactions Between Die Cushion and Process Enables Realistic Blank Holder Force Predictions", *Sciverse Science Direct* vol. 12, pp 273-278, 2012.
29. Hao S., Klamecki B.E., Ramalingam S., "Friction Measurement Apparatus for Sheet Metal Forming", *Wear (Elsevier)*, vol. 224, pp 1-7, 1999.
30. Hassan M.A., Takakura N., Yamaguchi K. "Friction Aided Deep Drawing Using Newly Developed Blank-Holder Divided into Eight Segments", *International Journal of Machine Tools & Manufacture*, vol.43, pp 637-646, 2003
31. Hassan M.A., Takakura N., Yamaguchi K., "A Novel Technique of Friction Aided Deep Drawing Using a Blank-Holder Divided into Four Segments", *Journal of Materials Processing Technology* Vol.139, pp 408–413, 2003.
32. Hassan M.A., Suenaga R., Takakura N., Yamaguchi K., "A Novel Process on Friction Aided Deep Drawing Using Tapered Blank Holder Divided into Four Segments", *Journal of Materials Processing Technology* Vol. 159, pp 418–425, 2005.

33. Hassan M.A., Saleh M.A.E. , Takakura N. , Ramesh S., Purbolaksono J. "Effect of Bulge Shape on Wrinkling Formation and Strength of Stainless Steel Thin Sheet", *Journal of Material and Design*, vol. 42 pp 37-45, 2012.
34. Henriques Marisa P., de Sousa Ricardo J. Alves, Valente Robertt A. F., "Numerical Simulation of Wrinkling Deformation in Sheet Metal Forming", *Portuguese Science and Technology Foundation*, pp 1-12, 2009.
35. Hol J., Cid Alfaro M.V., De Rooij M.B., Meinders T., "Advanced Friction Modeling for Sheet Metal Forming", *Wear (Elsevier)*, vol.286-287, pp 66-78, 2012.
36. Hu Zhenyu "Realisation and Application of Size Dependent FEM-Simulation for Deep Drawing of Rectangular Work Pieces", *CIRP Journal of Manufacturing Science and Technology*, vol.4, pp 90-95, 2011.
37. Intarakumthornchai Thanasan, Jirathearanat Suwat, Thongprasert Sirichan, Dechaumphai Pramote, "FEA Based Optimization of Blank Holder Force and Pressure for Hydro mechanical Deep Drawing of Parabolic Cup Using 2-D Interval Halving & RSM Methods", *Engineering Journal*, vol. 14, Issue No. 2, pp. 15-32, 2010.
38. Jaisingh Amit, Narasimhan K., Date P.P., Maiti S.K., Singh U.P. "Sensitivity Analysis of a Deep Drawing Process for Miniaturised Products", *Journal of Material Processing Technology*, vol. 147, pp 321-327, 2004.
39. Jayahari Lade, Sasidhar P.V., Prudvi Reddy P., BaluNaik B., Gupta A.K., Singh Swadesh Kumar, "Formability Studies of ASS 304 and Evaluation of Friction for Al in Deep Drawing Setup at Elevated Temperatures Using LS-DYNA", *Journal of King Saud University – Engineering Sciences* Vol.26, pp 21–31, 2014.
40. Jun-chao LI, Chong LI, Tong-gui Zhou, "Thickness Distribution and Mechanical Property of Sheet Metal Incremental Forming Based on Numerical Simulation" , Elsevier Science Press Science Direct, vol. 22, pp 54-60, 2012.
41. Kadkhodayan M., Moayyedean F. "Analytical Elastic–Plastic Study on Flange Wrinkling in Deep Drawing Process" *Scientia Iranica*, vol.18, pp 250-260, 2011.
42. Kakandikar G.M., Nandedkar V.M., "Optimization of Forming Load and Variables in Deep Drawing Process for Automotive Cup Using Genetic Algorithm", pp 1-10, 2005.
43. Kandil Anwar "An Experimental Study of Hydroforming Deep Drawing", *Journal of Material Processing Technology*, vol.134, pp 70-80, 2003
44. Karupannasamy D.K., Hol J., deRooij M.B., Meinders T., Schipper D.J. "Modelling Mixed Lubrication for Deep Drawing Processes" *Wear (Elsevier)*, vol. 294-295, pp.296-304, 2012.
45. Khelifa M., Oudjene M. "Numerical Damage Prediction in Deep Drawing of Sheet Metals", *Journal of Material Processing Technology*, vol. 200, pp 71-76 2008.
46. Kim Hyunok, Sung Ji Hyun, Sivakumar Rajesh, Altan Taylan, "Evaluation of Stamping Lubricants Using the Deep Drawing Test", *International Journal of Machine Tools & Manufacture*, vol. 47, pp 2120-2132, 2007.
47. Kim Y.S., Jain M.K. , Metzger D.R "Determination of Pressure Dependent Friction Coefficient From Draw Bend Test and its Application to Cup Drawing", *International Journal of Machine Tools and Manufacture*, vol 56, pp 69-78, 2012.
48. Lang Lihui, Li Tao, An Dongyang, Chi Cailou, Nielsen Karl Brian, Danckert Joachim, "Investigation into Hydro Mechanical Deep Drawing of Aluminum Alloy—Complicated Components in Aircraft Manufacturing", *Materials Science and Engineering A*, vol. 499, pp 320–324, 2009.
49. Liu Qiqian, Lu Cheng, Fu Wenzhi, Tieu Kiet, Li Mingzhe, Gong Xuepeng "Optimization of Cushion Conditions in Micro Multi-Point Sheet Forming" *Journal of Material Processing Technology*, vol.212, pp 672-677, 2012.
50. Lou Yanshan, Huh Hoon, Lim Sungjun, Pack Keunhwan, "New Ductile Fracture Criterion for Prediction of Fracture Forming Limit Diagrams of Sheet Metals", *International Journal of Solids and Structures*, vol. 49, pp 3605-3615, 2012.
51. Magar Susheel Madhavrao, Khir Mohan Yashwant, "Deep Drawing of Cup Shaped Steel Component: Finite Element Analysis and Experimental Validation", *International Journal on Emerging Technologies*, vol.1, Issue No. 2, pp 68-72, 2010.
52. Malekani J., Pour Mostafa A., Eskandarzade M. and Totonchi Abolfazl, "Numerical and Experimental Investigation on Die and Blank Holder shape in Deep Drawing Process", *Journal of Applied Sciences*, vol.8, Issue No. 11, pp 2153 – 2157, 2008.
53. Manabe Kenichi, Koyama Hiroshi, Yoshihara Shoichiro, Yagami Tetsuya "Development of a Combination Punch Speed and Blank-Holder Fuzzy Control System for the Deep-Drawing Process", *Journal of Material Processing Technology*, vol.125-126, pp 440-445, 2002.



54. Molotnikov A., Lapovok R., Gu C.F., Davies C.H.J. Davies, Estrin Y., "Size Effects in Micro Cup Drawing", *Material Science and Engineering*, vol. 550, pp 312- 319, 2012.
55. Morovvati M.R., Mollaei-Dariani B., Asadian-Ardakani M.H. "A Theoretical Numerical and Experimental Investigation of Plastic Wrinkling of Circular Two Layer Sheet Metal in the Deep Drawing", *Journal of Materials Processing Technology*, vol. 210 pp 1738-1747, 2010.
56. Nanu N., Brabie G. "Analytical Model for Prediction of Spring Back Parameters in the Case of U Stretch– Bending Process as a Function of Stresses Distribution in the Sheet Thickness", *International Journal of Mechanical Sciences*, vol. 64, pp 11- 21 2012.
57. Natarajan S., Venkataswamy S., Bagavathiperumal P. "A Note on Deep Drawing Process: Numerical Simulation and Experimental Validation" *Journal of Materials Processing Technology*, vol. 127, pp 64-67, 2002.
58. Ouakdi E.H., Louahdi R., Khirani D. , Tabourot L., "Evaluation of Spring Back Under the Effect of Holding Force and Die Radius in a Stretch Bending Test", *Materials and Design*, vol. 35, pp 106-112, 2012.
59. Padmanabhan R., Oliveira M.C., Alves J.L., Menezes L.F. "Influence of Process Parameters on the Deep Drawing of Stainless Steel", *Finite Elements in Analysis and Design*, vol.43 pp 1062 – 1067, 2007.
60. Peled A., Rubin M.B., Tirosh J. "Analysis of Blank Thickening in Deep Drawing Processes Using the Theory of a Cosserat Generalized Membrane", *Journal of the Mechanics and Physics of Solids*, vol.52, pp 317-340, 2004.
61. Pereira Michael P. , Weiss Matthias, Rolfe Bernard F., Hilditch Tim B. "The Effect of the Die Radius Profile Accuracy on Wear in Sheet Metal Stamping", *International Journal of Machine Manufacturing*, vol. 66, pp 44-53, 2013.
62. Reddy R. Venkat, Reddy T.A. Janardhan, Reddy G.C.M., "Effect of Various Parameters on the Wrinkling In Deep Drawing Cylindrical Cups" *International Journal of Engineering Trends and Technology* vol.3, Issue No. 1, pp 53- 58, 2012.
63. Robert C., Delameziere A., Dal Santo P., Batoz J.L. "Comparison between Incremental Deformation Theory and Flow Rule to Simulate Sheet-Metal Forming Processes", *Journal of Material Processing Technology*, vol. 212, pp 1123–113, 2012.
64. Salehinia I., Shahani A.R. "Effect of Sheet Anisotropy on the Wear in Deep-Drawing Process of a Cylindrical Cup", *International Journal of Mechanical Sciences*, vol. 21, pp 856-868, 2009.
65. Saniee F. Fereshteh, Montazeran M.H., "A Comparative Estimation of the Forming Load in the Deep Drawing Process", *Journal of Materials Processing Technology*, vol. 140, pp 555–561, 2003.
66. Saxena Ravindra K., Dixit P.M. "Numerical Analysis of Damage for Prediction of Fracture Initiation in Deep Drawing", *Finite Element Analysis and Design*, vol. 47, pp 1104-1117, 2012.
67. Signorelli J.W., Serenelli M.J., Bertinetti M.A., "Experimental and Numerical Study of the Role of Crystallographic Texture on the Formability of an Electro-Galvanized Steel Sheet", *Journal of Materials Processing Technology*, vol. 212 ,pp 1367– 1376, 2012.
68. Sokolova O.A., Kuhn M., Palkowski H., "Deep Drawing Properties of Lightweight Steel/Polymer/Steel Sandwich Composites", *Archive of Civil and Mechanical Engineering*, vol. 12, pp 105-112, 2012.
69. Tabourot L., Vacher P., Coudert T., Toussaint F., Arrieux R., "Numerical Determination of Strain Localization During Finite Element Simulation of Deep Drawing Operation", *Journal Material Processing Technology*, vol.159, pp 152-158 2005.
70. Talic Amra, Suad Hasanbegovic Suad, Uzunovic Nermina Zaimovic, "Determination of the Optimum Blank Shape in Rectangular Cup Drawing", "Trends in the Development of Machinery and Associated Technology", pp 881-884, 2009.
71. Thiruvarudchelvan S., Wang H.B., Seet G., "Hydraulic Pressure Enhancement of the Deep-Drawing Process to Yield Deeper Cups", *Journal of Materials Processing Technology*, Vol. No. 82, pp. 156–164, 1998.
72. Thiruvarudchelvan S., Tan M.J., "Fluid-Pressure-Assisted Deep Drawing", *Journal of Materials Processing Technology*, Vol. 192-193, pp 8–12, 2007.
73. Tommerup Soren, Endelt Benny "Experimental Verification of a Deep Drawing Tool System for Adaptive Blank Holder Pressure Distribution", *Journal of Material Processing Technology*, Vol. 212 pp 2529- 2540, 2012.
74. Thuillier S., Manach P.Y., Menezes L.F. "Occurrence of Strain Path Changes in a Two Stage Deep Drawing Process", *Journal of Material Processing Technology*, Vol.210, pp 226-232, 2010.
75. Van Tung Phan, Jochen Katja, Bohlke Thomas "Simulation of Sheet Metal Forming Incorporating EBSD Data", *Journal of Material Processing Technology*, vol.212, pp 2659-2668, 2012.

76. Volk Mihael, Nardin Blaz, Dolsak Bojan, "Application of Numerical Simulations in the Deep-Drawing Process and the Holding System with Segments' Inserts", *Journal of Mechanical Engineering*, vol. 57, Issue No. 9, pp 697-703, 2011.
77. Wan Min, Yung Yu-Ying, Li Shuo-Ben, "Determination of the Limiting Drawing Coefficient in the Deep Drawing of Conical Cups", *Journal of Materials Processing Technology*, vol.114, pp114-117, 2001.
78. Wifi A, Mosallam A, "Some Aspects of Blank-Holder Force Schemes in Deep Drawing Process", *Journal of Achievements in Materials and Manufacturing Engineering*, Vol. 24, Issue No. 1, pp 315 – 323, 2007.
79. Wu J., Balendra R., Qin Y., "A Study on the Forming Limits of the Hydro-Mechanical Deep Drawing of Components with Stepped Geometries", *Journal of Materials Processing Technology*, vol.145, pp 242-246, 2004.
80. Xu Dongkai, Chen Jun, Tang Yucheng, Cao Jian, "Topology Optimization of Die Weight Reduction for High-Strength Sheet Metal Stamping", *International Journal of Mechanical Sciences*, vol. 59, pp 73-82, 2012.
81. Yang T.S. "Investigation of the Strain Distribution with Lubrication During the Deep Drawing Process", *Tribology International*, vol. 43, pp 1104–1112, 2010.
82. Zhao S.D., Zhang Z.Y., Zhang Y., Yuan J.H. , "The Study on Forming Principle in the Process of Hydro-Mechanical Reverse Deep Drawing with Axial Pushing Force for Cylindrical Cups", *Journal of Materials Processing Technology*, vol. 187-188, pp 300-303 2007.

#### AUTHORS

**First Author** – Chandra Pal Singh, PhD Scholar, MANIT Bhopal [chandraid@gmail.com](mailto:chandraid@gmail.com)

**Second Author** – Dr. Geeta Agnihotri, Profesore MANIT Bhopal.

**Correspondence Author** – Chandra Pal Singh, PhD Scholar, MANIT Bhopal [chandraid@gmail.com](mailto:chandraid@gmail.com), 09826227054.

# THE WVSU-Lambunao Campus College Freshmen: Who, What, and Why

Nelson G. Laru-an\*, Dominador L. Lisao\*\*

\* Associate Professor, Director, School of Management  
\*\* Associate Professor, Campus Administrator

**Abstract-** This action research was conducted here at WVSU-LC during the school year 2013-2014. The subjects of the study were the selected college freshmen who were taking courses leading to bachelor's degree in Education, Criminology, Hotel and Restaurant Management, Information Technology, Industrial Technology, and Foods Technology. The data gathering instrument was a duly-validated researcher made questionnaire jointly prepared by the guidance counselor and the researcher. The data was collected by requesting college freshmen to fill up the questionnaire during enrollment period. After the data have completed, the questionnaire was forwarded to the researcher for tabulation. Frequencies, percentages, and means were the statistical tools. The findings revealed that there were two hundred eighty two (282) randomly selected college freshmen for school year 2013-2014. The largest group were enrolled in criminology, followed by those taking education courses, and the smallest group were those in food technology. The mean age was 18.29 years, mostly females, majority were residents of Lambunao and nearby municipalities. Their high school average grades ranged from 77.76 to 86.27, and their WVSU-CAT scores showed that 12% 114.54 the highest, and 18% belongs to the lowest of 97.31. Few of them have already attended college education and decided to transfer to WVSU-LC. Both parents of the majority of these freshmen were still alive, attended elementary education or not all, mostly farmers, laborers, drivers and carpenters and the mothers were plain housewives. More than 90% of these students enrolled at WVSU-LC at their own choice. The most common reasons were 1) they believe that WVSU-LC provides quality education, 2) the cost of education is much lower, 3) develop skills needed for earning a living, 4) near their homes, and 5) were relevant to job opportunities. Some students indicated that their parents choose the school for them, and the most reasons is that the only capacity could tackle. Majority were supported by their parents, uncles and aunts, elder siblings and grandparents. Scholarships were enjoyed by few, most of them were barangay scholars, SK, CHED, DOST, Lambunao Foundations, some worked as school boy/girl, and 9 as student assistant. If tuition fees will be increased by P50.00 by next semester 82.68% indicated that they still enroll, while 9.42 indicated that they will stop due to financial difficulties and 7.90% answered that they will transfer to other schools that charge lower tuition fee rates.

## I. INTRODUCTION

The idea of knowing the kind of students who come and enroll at WVSU-Lambunao Campus, Lambunao, Iloilo have

significant impact on their learning, therefore the knowledge on the part of administration in providing their needs is essential Gines et al. (1998).

The present study would enable the instructors at WVSU-LC to know their students better and promote a more harmonious relationship between the faculty and the students. In the same manner, policy- making on the part of the administration would be more relevant to the needs and capacities of the students Alajar (1994).

Through this study, the student's reason for enrolling in WVSU-LC is revealed and would be the bases for planning and decision-making.

This action research which would be conducted here in WVSU-LC during the school year 2013-2014. The subjects were the selected college freshmen who were taking courses leading to a bachelor's degree in Education, Criminology, Hotel and Restaurant Management, Information Technology, Industrial Technology, and Food Technology. The data gathering instrument was a researcher made and duly validated questionnaire which was jointly prepared by the Guidance Counselor and the researcher. Data was collected by requesting college freshmen to fill up the questionnaire during the enrollment period. After all freshmen have completed the questionnaires, these would be forwarded by the Guidance Counselor to the researcher for the tabulation of the data. Frequencies, percentages, and means were the statistical tools to be used in this study.

## II. OBJECTIVES OF THE STUDY

This study was conducted with the following objectives:

1 To draw a profile of the SY 2013-2014 college freshmen of WVSU-LC in terms of:

1.1 courses,

1.2 age,

1.3 gender,

1.4 place of origin/hometown,

1.5 high school GPA,

1.6 high school average grade, GPA grade point average

1.7 parent's educational attainment, and

- 1.8 parent's occupation/source of income,
2. To find out the students reasons for enrolling at WVSU-LC.
3. To find out the students reasons for enrolling in the courses they have enrolled in.

### III. FRAMEWORK

This study was conducted in WVSU-LC during the SY 2013-2014. The subjects/respondents were the randomly selected college freshmen during the same school year, who were taking courses leading to a bachelor's degree in Education, Criminology, Hotel and Restaurant Management, Information Technology, Industrial Technology and Foods Technology.

The research instrument was a researcher made and duly validated questionnaire which was jointly prepared by the Guidance Counselor and the researcher.

Upon presentation of the credentials required for admission to WVSU-LC and with the instructions from the Guidance Counselor, the respondents were requested to fill up the questionnaires by supplying the needed data asked for. Selected college freshmen who were taking courses leading to a bachelor's degree were included in the study. After completing the questionnaires; these were turned over by the Guidance Counselor to the Researcher for tabulation, presentation and interpretation.

Frequencies, percentages, and means were the statistical tools to be used in the study.

### IV. RESULTS AND DISCUSSIONS

There were two hundred eighty two (282) randomly selected freshmen for SY 2013-2014 at WVSU-LC. They were enrolled the different courses leading to a bachelor's degree in criminology, elementary and secondary education, food technology, hotel and restaurant management, technical teacher education, industrial technology, and information technology. The largest group was of these freshmen enrolled in criminology. This was followed by those taking education courses and the smallest groups are those in food technology.

The mean age of these college freshmen was 18.29 years. They were mostly females. Majority of whom were residents of the Municipality of Lambunao and other municipalities nearby. Most of them graduated from national high schools which are also located in Lambunao and the neighboring municipalities. Their high school average grade ranged from 77.76 to 86.27 with a mean of 83.48. Further, their WVSU CAT results showed that 12% within 114.54 which is the highest and 18% belongs to the lowest 97.31.

Few of them have already attended college previously in other institutions and have decided to transfer to WVSU-LC.

Both parents of the majority of the freshmen were still alive, although there were some, comprising 14.21% of them, who had already lost one or both of their parents. Majority of the respondent's fathers have attained only elementary education or none at all. The same level of education was attained by 48.96% of their mothers. Relative to the educational attainment and

occupation of their fathers who were mostly farmers, laborers, drivers, and carpenters. Their mothers were mostly housewives, although some worked as vendors, teachers, farmers, and businesswomen. More than 90% of the freshmen indicated that they enrolled at WVSU-LC at their own choice. The most common reasons were that 1) they believe that WVSU-LC provides quality education, 2) the cost of education in WVSU-LC is much lower than in other schools, 3) they agreed that WVSU-LC develops skills needed for earning a living, 4) WVSU-LC is near their home, and 5) they observe that courses offered at WVSU-LC are relevant to available job opportunities.

Some of the freshmen who indicated that their enrollment in WVSU-LC was not their own choice revealed that their parents chose the school for them. The parent's reason were mostly that 1) that WVSU-LC provides quality education, 2) the cost of education in WVSU-LC is much lower than in other school, 3) the course that they have chosen was that they considered to be the best choice among the courses offered in WVSU and, 4) the course is the only one which their intellectual capacity could tackle. Majority of the freshmen were supported financially by their parents. Some of them received support from their uncles and aunts, elder siblings and grandparents.

Scholarships were enjoyed by only 34 of these freshmen, most of whom were barangay scholars, while the rest were scholars of the municipal council, the Congressional Scholars, Sangguniang Kabataan, TESDA, CHED, DOST, Lambunao Foundations, and other benevolent Lambunaoons.

While others were enjoying scholarships and support of their parents and family, there were some less fortunate students who were only working their way through college. To support their studies, there were 25 freshmen who worked as school boy/girl, 9 who were serving as student assistants, and 7 who worked in private offices or establishments.

If the rate of the tuition fee would be increased by P50/unit by the next semester, 82.68% of the freshmen indicated that they will still enroll in WVSU-LC. While 9.42% indicated that they would stop studying due to financial difficulties the remaining 7.90% answered that they would transfer to other schools that charge lower tuition fee rate.

### V. CONCLUSIONS

Based on the findings of the study, the following conclusions were drawn:

1. For the school year 2013-2014, more freshmen were enrolled in criminology course than in education course. They mostly came from national high schools in Lambunao and the nearby municipalities. The males were outnumbered by females. For most of the freshmen, both had very low educational attainment which explains why they mostly came from low income families, their fathers being mere farmers, laborers, drivers, and fishermen and carpenters while their mothers were plain housewives.

2. Although several of them were enjoying scholarships and others worked to support their studies, majority of these freshmen were dependent on their parents for their education and since these parents were not engaged in high-earning jobs, the freshmen for SY 2012-2013 were mostly financially handicapped.

3. Being enrolled in WVSU-LC was more of their own choice than that of their parents, but no matter who choose it that they enroll in this college, the reasons were obvious: 1) they liked the kind of instruction the WVSU-LC gives, and 2) the economic reason that at WVSU-Lambunao Campus, they pay a lower tuition fee rate than what they would pay in other schools or colleges. This goes to show that both the student and their parents believed that at WVSU-LC, education is made cheaper without sacrificing the quality of instruction that they get.

4) Generally, the freshmen liked the course they have enrolled in. For those who felt otherwise, enrolling in the course was the best thing that they could do. There was no other choice for them, partly because they were financially handicapped.

5) While there were indications that some freshmen would leave WVSU-LC when tuition fee rate is increased, majority of them were willing to pay an additional tuition fee of P 50.00/unit by the next semester despite their financial handicaps.

REFERENCES

- [1] Alajar, E. (1994). The relationship between fourth year students' final grades in mathematics science and English and their college freshmen performance, Unpublished Seminar Paper, West Visayas State University, Iloilo City.
- [2] Gines, A. et al (1998). Educational psychology, New Edition, Rex Book Store, Inc. p. 231.

AUTHORS

**First Author** – Nelson G. Laru-an, Ed. D., Associate Professor  
Director, School of Management, Wvsulc.som@mail.com

**Second Author** – Dominador L. Lisao, Ed. D., Associate  
Professor, Campus Administrator, Wvsulc.som@mail.com

Questionnaire for the Students (First Year Only)

I Profile of Students

- 1.1. Course: \_\_\_\_\_
- 1.2. Age: \_\_\_\_\_
- 1.3. Sex: \_\_\_\_\_
- 1.4. Place of Origin/Hometown: \_\_\_\_\_
- 1.5. Type of High School Graduated: \_\_\_\_\_
- 1.6. Location of High School Graduated: \_\_\_\_\_
- 1.7. High School Grade Point Average: \_\_\_\_\_
- 1.8. Parent's Occupation/Income: \_\_\_\_\_
- 1.9. Government Support in High School: \_\_\_\_\_
- 2.0. Health Support in High School: \_\_\_\_\_
- 2.1. Hobbies and Interest in High School: \_\_\_\_\_
- 2.2. Indigenous Tribe: \_\_\_\_\_
- 2.3. Indigenous Scholarship: \_\_\_\_\_
- 2.4. WVSU CAT Score: \_\_\_\_\_

2. To find out the sources of funds of their education: \_\_\_\_\_

3. Do have social support from relatives, friends, etc. \_\_\_\_\_

4. To find out the students reasons for enrolling at WVSU-LC: \_\_\_\_\_

5. Reason for choosing the course: \_\_\_\_\_

(SGD.) NELSON G. LARU-AN, Ed. D.

Researcher



# Level of Effectiveness of Community Policing

Nelson G. Laru-an, Harrah T. Beup

**Abstract-** The purpose of the study aimed to determine the level of effectiveness of community policing in the field of patrol operations, traffic investigations, and criminal investigations of police officers in the 5<sup>th</sup> District of Iloilo for the year 2014. The data gathering instrument was adopted from Basic Procedures of the PNP Manual(2010). The respondents of the study were the one hundred seventy seven local government units in the municipalities of the 5<sup>th</sup> District of the province. The findings revealed that the level of effectiveness of community policing in patrol operations was generally effective and when grouped as sex and old respondents. The young respondents on the other hand rated very effective. The level of effectiveness of community policing in traffic investigation was effective when grouped as to various categories. Finally the level of community policing in criminal investigation was effective when classified as to old, and male respondents, and the young and female respondents as very effective.

## I. INTRODUCTION

The demand for public safety services involves a wide range of issues and considerations to be effective police officers. Reforms in the operating rules and procedures in the police operations by providing police units the appropriate work tools, and training for the effective implementation of police operations to ensure peace and order condition, and safety of the people and their property in the community.

This study is anchored on the theory of reciprocal responsibility of the Police Community Relations Manual of 2003 of the Philippine National Police (PNP) which provides that the police on their own cannot effectively prevent and control crime. To ensure the success of Community Oriented Policing System (COPS), the community must be viewed as the stakeholder. It is true that crime is everybody's business. However, some citizens are not aware of this responsibility. The community must help in eradicating the causes of criminality such as the following:

Manwong and Delizo (2006) state that intensive or massive poverty can be singled out as the primary cause of crime in the underdeveloped countries such as the Philippines. This is characterized by intensive widespread of unemployment, underemployment due to lack of job opportunities, low income and productivity, rapid population growth rates, and others. Due to poverty, many of the people become desperate and forced by circumstances to resort to crime for them to escape from their miseries and frustrations.

The basic idea behind community policing is that, the community must be involved with police to solve problems. As

simple as this may sound, police must accept the fact that the community has to be involved in the process from the beginning. The goal is to promote police community partnerships. Problem solving is a new way of policing to address not only the causes of crime and the fear of crime but all quality of life issues in the community.

## II. RESEARCH ELABORATIONS

This study was conducted to check the level of effectiveness of the community policing programs as provided for by the Police Community Relations Manual (2003) in the municipalities of the 5<sup>th</sup> District of Iloilo in patrol operations, traffic investigation, and criminal investigation.

Likewise the present study used a descriptive survey. The respondents were the local government units of the said district.

According to Ardales (2001) descriptive research involves description of the nature and situation as it exists at the time of the study and explores the causes of particular phenomenon and the interpretation of the condition exist. He further emphasizes that descriptive research involves the collection of data in order to answer questions concerning the current status of the subject under study. This design is considered appropriate for this study because the aim is to determine the effectiveness of police officers in community policing as perceived by the elected barangay officials.

What is the level of effectiveness of community policing programs as provided by Police Community Relations Manual in patrol operations, traffic investigation, and criminal investigation hence, this study.

What is the level of effectiveness of community policing in patrol operations, traffic investigation and criminal investigation as perceived by the barangay officials as an entire group, and when classified as to age, and sex?

Are there significant differences in the level of effectiveness of community policing in patrol operations, traffic investigation, and criminal investigation as perceived by barangay officials of the classified as to age, and sex?

The subjects of the study were the one hundred seventy-seven (177) randomly selected barangay officials of the different municipalities in the 5<sup>th</sup> District of Iloilo, represented the civilian sector. These barangay officials were taken from different towns of the 5<sup>th</sup> Congressional District of the Province Iloilo namely Ajuy, Balasan, Barotac Viejo, Batad, Carles, Concepcion, Estancia, Lemery, San Dionisio, San Rafael, and Sara.

The distribution of respondents are shown in Table I

**Table I**  
*Distribution of Respondents*

Categories	N	Percentage
Entire Group	177	100
Age		
Young	77	44
Old	100	56
Sex		
Male	81	46
Female	96	54

The questionnaire-checklist has Two parts. Part I – contained the personal profile accomplished by the respondents.

Part II – consisted of items that determined the assessment of the respondents to the existing community policing as implemented in the 5<sup>th</sup> District of Iloilo.

Each response was assigned a corresponding value for statistical purpose as follows:

Weight	Responses
4	Strongly Agree
3	Agree
2	Disagree
1	Strongly Disagree

To determine the significant differences in the implementation of the community policing according to categories, the Mann-Whitney Test was used as inferential statistics set at 0.05 alpha.

*Level of Effectiveness of Community Policing in Patrol Operations*

The findings revealed that the level of effectiveness of community policing in patrol operations is effective when the respondents are taken as an entire group (M=3.2571, SD=.3890).

As to age of the barangay officials, the young perceived the community policing as very effective (M=3.2610, SD=.3763); the old perceived it as effective (M=3.2540, SD=.4004).

As to sex, both the male (M=3.2568, SD=.4012) and female (M=3.2573, SD=.3805) perceived the policing as effective.

III. RESULTS

The initial findings of the investigation revealed the level of effectiveness of community policing in patrol operations, traffic investigation, and criminal investigation as an entire group, and when classified as to age, and sex is reflected in Table 2.

**Table 2**  
*Level of Effectiveness of Community Policing in Patrol Operations*

Categories	N	Mean	Description	S.D.
Entire Group	177	3.2571	Effective	.3890
Age				
Young	77	3.2610	Very Effective	.3763
Old	100	3.2540	Effective	.4004
Sex				
Male	81	3.2568	Effective	.4012
Female	96	3.2573	Effective	.3805
	<i>Scale</i>		<i>Description</i>	
	3.26-4.00		Very Effective	
	2.51-3.25		Effective	
	1.76-2.50		Less Effective	
	1.00-1.75		Not Effective	

*Level of Effectiveness of Community Policing in Traffic Investigation*

In traffic investigation, the perceived level of effectiveness was effective as an entire group (M=3.1966, SD=.4548). When grouped according to age, both the young (M=3.2442, SD=.4396) and the old (M=3.1600, SD=.4649) perceived it as effective. When classified according to sex, both male (M=3.2136, SD=.4027) and female (M=3.2136, SD=.4027) perceived it as of effective.

**Table 3**  
*Level of Effectiveness of Community Policing in Traffic Investigation*

Category	N	Mean	Description	S. D.
Entire Group	177	3.1966	Effective	.4548
Age				
Young	77	3.2442	Effective	.4396
Old	100	3.1600	Effective	.4649
Sex				
Male	81	3.2136	Effective	.4027
Female	96	3.1823	Effective	.4961
<i>Scale</i>		<i>Description</i>		
3.26-4.00		Very Effective		
2.51-3.25		Effective		
1.76-2.50		Less Effective		
1.00-1.75		Not Effective		

*Level of Effectiveness of Community Policing in Criminal Investigation*

In criminal investigation, the perceived level effectiveness as entire group was effective when taken as an entire group (M=3.2492, SD =.4168).

When classified according to age, the young respondents rated it as very effective (M=3.2623, SD=.4283). While the old respondents rated as effective (M=3.2390, SD .4097). When grouped according to sex, the male respondents perceived it as effective (M=3.2333, SD .4542) while the female respondents perceived it as very effective (M=3.2625, SD=.3834).

This is reflected in Table 4.

**Table 4**  
*Level of Effectiveness of Community Policing in Criminal Investigation*

Category	N	Mean	Description	S.D.
Entire Group	177	3.2492	Effective	.4168
Age				
Young	77	3.2623	Very Effective	.4283
Old	100	3.2390	Effective	.4097
Sex				
Male	81	3.2333	Effective	.4552
Female	96	3.2625	Very Effective	.3834
<i>Scale</i>		<i>Description</i>		
3.26-4.00		Very Effective		
2.51-3.25		Effective		
1.76-2.50		Less Effective		
1.00-1.75		Not Effective		

**IV. CONCLUSIONS**

Based from the findings above, the researcher established the following conclusions:

The community policing in patrol operations was rated effective by most of the respondents, except for those belonging to the young group who rated it as very effective. With these findings in hand, it goes to show that the members of the police force had been treating people with respect and sensitivity and maintaining a good working relationship with the people in the community. Patrol operations has something to do with being visible to the people in the community which gives them a

feeling of security while taking away the opportunity from the would-be criminals.

The community policing in traffic investigation was rated effective regardless of the respondents' age and sex. It reflects that there are areas that need to be improved and enhanced, especially with the maintenance of traffic facilities. The response may also be due to the fact of the continuous rise of vehicular accidents in the municipalities of the 5<sup>th</sup> District of Iloilo.

The community policing in criminal investigation was rated generally as effective with the exception of the young and female group who rated it as very effective. This maybe a reflection that some police officers persevere to finish the task despite of the

many obstacles that surrounds a case. The slight difference between the responses of the young from the old group stressed that maybe the young group are more observant or more involved in cases. The female group gave the response of very effective maybe because they tend to follow a particular case until it is solved.

#### REFERENCES

- [1] Ardales, V. (2001). Basic concepts and methods in research . Quezon City, Great Books Trading.
- [2] Manwong, R. & Delizo, D. (2006). Law enforcement administration, RK: Manwong Publications.
- [3] Police Community Relations Manual (2003).

#### AUTHORS

**First Author** – Nelson G. Laru-an  
**Second Author** – Harrah T. Beup

Questionnaire of the Level of Effectiveness of Community Policing

I Respondent's profile

Name: \_\_\_\_\_ Age: \_\_\_\_\_ sex: \_\_\_\_\_  
 Municipality: \_\_\_\_\_

II the questionnaire proper

Instruction: please answer this questionnaire properly and sincerely by putting a tick mark (✓) on the space that best corresponds to your observation on the following items using the following criteria:

Scale	Description
4	Strongly agree (SA)
3	Agree (A)
2	Disagree (D)
1	Strongly disagree (SD)

Responses

Patrol operations

1. PNP personnel have a collaborate partnership with individuals and organizations and the community. 4 3 2 1
2. The police officers are most of the time visible in the community. 4 3 2 1
3. The police treat people with respect and sensitivity. 4 3 2 1
4. Police officers maintain a good working relationship with the common people. 4 3 2 1
5. The presence of the police in the local area helps reduce the occurrence of crimes. 4 3 2 1
6. The police officers report to barangay authorities the movement of questionable people in the community. 4 3 2 1
7. PNP creates programs activities that are useful to the community to reduced and solve crime and crime-related problems. 4 3 2 1
8. There is equal distribution of police services and resources among barangays in the municipality. 4 3 2 1
9. Electronic communication equipment and devices are properly provide to ensure easy and fast response to the needs of the community. 4 3 2 1
10. The presence of the policemen in the local areas creates awareness of the occurrence of crimes. 4 3 2 1

Traffic investigations

11. The PNP members are quick to respond in reported vehicular accidents. 4 3 2 1
12. The PNP officers conduct seminars about traffic law, rules and regulations. 4 3 2 1
13. The police officers collaborate with the LGU in the effective construction and maintenance of traffic facilities. 4 3 2 1
14. The PNP officers are particulars with presence of road sign. 4 3 2 1
15. The police officers are conducting periodic assessment of the factors



- contribution to road accidents. 4 3 2 1
16. The PNP officers can establish the chain of events in vehicular accidents from proper reporting system. 4 3 2 1
17. The police officers can conduct at-scene investigation properly. 4 3 2 1
18. The PNP personnel are knowledgeable of vehicular crime scene reconstruction. 4 3 2 1
19. The PNP officers perform proper collection of data to help them identify and classify a motor vehicle. 4 3 2 1
20. Most of the hit and run cases are more likely to be solve. 4 3 2 1
- Crime investigation
21. The police officers preserve or stick to the task in spite of the many obstacles which surrounds the case. 4 3 2 1
22. The police instigators treat all individuals according to the constitutional rights That officers are sworn to protect and enforce. 4 3 2 1
23. The police investigators observed proper procedures and methods in conducting search of the crime scene. 4 3 2 1
24. The police investigators follow the rules and elements of sketching the crime scene. 4 3 2 1
25. The police investigators consider interviews and interrogation as important tools in establish the suspect's identity. 4 3 2 1
26. The police investigators maintain contact with different groups of people as sources of information. 4 3 2 1
27. The police officers conduct surveillance activities to know the connection of the suspect to the crime. 4 3 2 1
28. The police investigators conduct follow-up investigation of reported cases. 4 3 2 1
29. The police investigators are updated with the new methods and scientific approach of investigation. 4 3 2 1
30. Report and files are properly maintained for easy retrieval of data that would help in the investigations. 4 3 2 1

# Effect of *Moringa Oleifera* Leaf Extracts Supplementation in Preventing Maternal Anemia and Low-Birth-Weight

Ishaq Iskandar<sup>1</sup>, Veni Hadju<sup>2</sup>, Suryani As'ad<sup>3</sup>, Rosdiana Natsir<sup>4</sup>

<sup>1</sup>Faculty of Medicine, Hasanuddin University, Makassar, South Sulawesi, Indonesia.

<sup>2</sup>Department of Public Health Nutrition, Hasanuddin University, Makassar, South Sulawesi, Indonesia.

<sup>3</sup>Department of Clinical Nutrition, Faculty of Medicine, Hasanuddin University, Makassar, South Sulawesi, Indonesia.

<sup>4</sup>Department of Biochemistry, Faculty of Medicine, Hasanuddin University, Makassar, South Sulawesi, Indonesia.

**Abstract-** The extracts of *Moringa oleifera* leaf have been proven to have potent anti oxidant activity, prevent oxidative damage, and afford significant protection against oxidative damage. This study aims to assess the effect of *Moringa oleifera* leaf extracts supplementation in preventing maternal anemia and low-birth-weight (LBW). This was a double blind, randomized control trial study, pretest-posttest controlled which conducted in Gowa District, South Sulawesi Province, Indonesia, from September 2012 to December 2013. Subjects in this study are 64 pregnant women. The result of the study discovered significant increase of hemoglobin level in the intervention group ( $p < 0.05$ ). *Moringa Oleifera* extract consumption increased the hemoglobin level to 58%. In the control group, the conformity of pregnant women has no significant effect to pregnant women hemoglobin level increase. *Moringa Oleifera* extract is able to retain ferritin serum level dismount up to 50%. LBW was not found in pregnant women who received *Moringa oleifera* leaf extract. Further research is needed to confirm the exact dose of *Moringa oleifera* leaf extracts.

**Index Terms-** *Moringa oleifera*, anemia, pregnant women, hemoglobin, ferritin, LBW.

## I. INTRODUCTION

Effects caused by malnutrition can be particularly associated with the micronutrients insufficiency, are zinc and iron deficiency. Both micronutrients play important role in development of the foetus. Multiple risks might happen whenever pregnant women suffer from malnutrition, including maternal bleeding, abortus, birth death, low-birth-weight, congenital defect, mental retardation etc<sup>1</sup>.

One of the main factor that might have harmful effect on foetus and the development of the newborn is pregnant women with anemia state, where the hemoglobin level in the blood below normal ( $\leq 11$  gr/dl). This might be caused by deficiency of iron, folic acid or B12 vitamin. Maternal anemia could cause harmful effect both to mother and the foetus, because it reduces oxygen supply on mother metabolism since the hemoglobin level is low to be able to bind the oxygen, and could cause indirect effect for the pregnant women and the newborn including birth death, premature birth, and low-birth-weight. In Pakistan,

maternal anemia responsible for 13% of pregnant women death and 27% of post partum bleeding<sup>2</sup>.

Based on research conducted by Saad (2008), revealed that iron intake twice a week effectively increase hemoglobin level on pregnant women by combining iron with other micronutrients (folic acid, vitamin A, vitamin C) compared to iron intake with only folic acid combination, nevertheless the average increase of hemoglobin level yet to show optimum result (0.59 gr/dl), thus it is necessary to create a more potent strategy by including nutrient education in that weekly supplementation of micronutrients<sup>3</sup>.

Low-birth-weight (LBW) recognized by the weight less than 2500 gram, and become one of the main risk of infant mortality. LBW also could cause interference in physical and mental development of the newborn. Some studies revealed that children that suffer from previous LBW having lower development pattern<sup>4</sup>.

*Moringa Oleifera* leaves have long been used to overcome the problem of malnutrition among children, pregnant women, and breastfeeding<sup>5</sup>. In addition, with micronutrients substances, *Moringa Oleifera* can be used an alternative supplement for pregnant women to prevent maternal anemia and LBW. Prevention of maternal anemia can decrease the incidence of pregnancy complication and low-birth-weight<sup>6</sup>. The purpose of this study was to assess the effect of *Moringa Oleifera* extracts to prevent maternal anemia and low-birth-weight.

## II. MATERIAL AND METHOD

The study design was double blind, randomized, pretest-posttest controlled. The first trimester pregnant women that meet the inclusion and exclusion criteria were recruited consecutively. Sixty-four pregnant women enrolled, randomized to intervention and controlled group.

The intervention conducted for 90 days from 12-20 weeks of pregnancy age. The intervention group received one capsule of *Moringa Oleifera* extracts in the morning and one capsule iron and folic acid in the night. Subjects in the control group received placebo capsules in the morning as well as iron and folic acid capsule in the night. Body weight measure, mid-upper arm circumference, and food recall conducted in the end of the fourth, eighth, and twelfth week. Biochemical examination (posttest) conducted in the thirteenth week. The weight and the length of the newborn measure conducted within one hour after the birth.

To retrieve the extract, *Moringa* leaves was washed by dipping it into saline water for 3-5 minutes, *Moringa* leaves then air-dried in room temperature until the water content reach 10%. After the *Moringa* leaves dried, there are 90gr plus 10gr bitter maccerated dipped with ethanol for 24 hours, this treatment was repeated 3 times, then filtered to separate and extract the pulp. The extract were evaporated at a temperature of 30-40<sup>o</sup> for 24 hours. The pulp was at a temperature 30-40<sup>o</sup> for 48 hours. The result then inserted into an extract *Moringa* capsule.

The acquired data was analysed using statistical package for social science (SPSS) program v.20, which includes Nutrisurvey, Univariat analysis, and Bivariat Analysis.

### III. RESULT AND DISCUSSION

Anemia status of pregnancy women in pre and post-intervention in both intervention and control group can be seen in the Table 1. Below.

**Table 1. Anemia status of pregnancy women pre and post-intervention.**

Variable	TO X SD	T3 X SD	Pair ed t- Test	Δ(T3- T0) X ± SD	Man n-U Whit ney
<b>Hb</b>					
<b>Interven tion</b>	11.19± 0.8	11.93± 0.9	0.00 3	0.73±1. 29	0.078
<b>Control</b>	11.5±0 .3	11.7±0 .3	0.26 8	0.21±1. 02	
<b>Ferritin</b>					
<b>Interven tion</b>	66.3±5 4.7	45.7±2 6.6	0.02 2	- 20.6±49	0.254
<b>Control</b>	65.4±8 1.2	26.9±1 9.0	0.00 7	.0 -	
				38.5±73 .4	
<b>Erythro cyte</b>					
<b>Interven tion</b>	3.8±0. 38	4.01±0 .28	0.69 1	0.28±0. 51	0.294
<b>Control</b>	3.9±0. 43	4.02±0 .34	0.11 5	0.15±0. 40	
<b>Hematoc rit</b>					
<b>Interven tion</b>	33.9±2 .5	35.4±1 .58	0.81 9	1.95±3. 55	0.133
<b>Control</b>	34.2±2 .7	36.3±2 .65	0.28 2	0.74±2. 79	

Table 1. Above shows that haemoglobin level in the intervention group significantly increased (p<0.05), but the difference in haemoglobin level increase is not significant (p>0.05). Intervention group have 0.73 gr/dl haemoglobin level increase, while in control group the increase was only 0.21 gr/dl. Average decrease of ferritin in intervention group 20.6 µg/ml, while in control group 38.5 µg/ml. The decrease ferritin level in both groups was significant (p<0.05) but the decrease difference were not significant (p>0.05). Erythrocyte and hematocrit level

in both groups also increase although the difference was not significant.

**Table 2. Distribution of birth-weight on both groups**

Birth Weight	Intervention		Control		P Value
	N(%)	X+SD	N(%)	X+SD	
<2.5 kg	0 (0)	0	1(3.3)	0	n/a
2.5kg - 3 kg	19(52.8)	2.82±0.21	17(47.2)	2.75±0.18	0.307
3.1kg- 3.5 kg	10(52.6)	3.16±0.19	9(47.4)	3.31±0.15	0.824
3.51kg- 4 kg	4(50.0)	3.70±0.08	4(50.0)	3.75±0.13	0.537
<b>Total</b>	33(51.6)	3.07±0.37	31(48.4)	3.03±0.43	0.650

The above table shows that the highest birth-weight was on intervention group 33 (51.6%) with the average birth weight 3.07kg. The birth-weight difference on both groups were not significant (p=0.650). Low-birth-weight is not found on the pregnant women in intervention group, while there are 3.20% low-birth-weight in the pregnant women which intervention with iron and folic acid.

The assesment of maternal anemia in this study was conducted by examination of complete blood count, which are hemoglobin level, hematocrit, and erythrocyte examination continued by assessment of mean corpuscular values. Maternal anemia is a systemic psychological and physiological adaptation, particularly in cardiovascular system specifically in blood volume. The blood volume increase is a protective mechanism induced by (1) the hypertrophy vascular system because of uterus enlargement<sup>7</sup>. (2) hydration of foetus and mother tissue that had to be adequate when stand up straight or when lie down, and (3) the fluid reserve to replace missing blood in parturition and puerperium process<sup>8</sup>.

Normal birth weight has normal range for each gestational period in weekly count<sup>9</sup>. Foetus development in gestational period assessed to be normal whenever the weight is accordance to the gestational period. This study report the gestational period were in 37 to 41 weeks with birth weight 2.200-4.000 gr. Birth weight is defined by foetus nutritional status as well as genetic factors. Foetus nutritional status is defined by the pregnant women nutritional status when delivering newborn and this condition is effected by the nutritional status in pre-conception women<sup>10</sup>. The ninety days supplementation of *Moringa oleifera* leaf extracts did not bring significant effect to the birth weight. This condition probably happen due to the exact dose of *moringa* extract was not to be determined yet.

In conclusion, *Moringa oleifera* leaf extracts have significant effect to increase hemoglobin level in pregnant women, could prevent ferritin serum dismount to 50%. Low-birth-weight was not found on the pregnant women in intervention group, while there are 3.20% low-birth-weight in the pregnant women in control group. Further research is needed to confirm the exact dose of *Moringa oleifera* leaf extracts.

#### REFERENCES

- [1] Sulistyoningsih, H. 2011. Nutrients For Baby and Children Health. Graha Ilmu Yogyakarta.
- [2] Bhutta ZA. et.al. 2009. A comparative evaluation of multiple and iron-folic acid supplementation during pregnancy in Pakistan: impact on pregnancy outcomes. *Food Nutr Bull.*; 30(4 Suppl):S496-505.
- [3] Saad. 2008. Iron supplementation efficacy study of Vitamin A and Vitamin C twice a day on hemoglobin level of pregnant women in Pinrang District. Postgraduate Thesis UNHAS
- [4] Priyo, S et al. 2009. Relationship between low-birth-weight with nutritional status of 1 to 3 years old children in Kelurahan Harjamukti Cirebon. Skripsi
- [5] Idohou D. et.al. 2011. Impact of daily consumption of Moringa (*Moringa oleifera*) dry leaf powder on iron status of Senegalese lactating women. *Ajfund Online*. 11(4):4986-99
- [6] Sreelatha, S and Padma, P.R. 2009. Antioxidant activity and total phenolic content of moringa *oleifera* leaves in two stages of maturity. *Plant Foods hum Nutr*, 64,303-311.
- [7] Allen, L.H 2000. Anemia and iron deficiency: effect on pregnancy outcome. *Am J.Clin Nutr*. 71.1280S-4S
- [8] Casanueva E., et.al. 2003. Iron and oxidative stress in pregnancy. *J. Nutr.*, 133.1700S-1708S.
- [9] Bobak. 2004. Basics of Maternity Nursing. EGC. Jakarta
- [10] Arisman. 2004. Nutrients in Life Cycles. EGC. Jakarta

#### AUTHORS

**First Author** - M. Ishaq Iskandar, Faculty of Medicine, Hasanuddin University, Makassar, South Sulawesi, Indonesia.

**Second Author** - Veni Hadju, Professor in Department of Public Health Nutrition, Hasanuddin University, Makassar, South Sulawesi, Indonesia.

**Third Author** - Suryani As'ad, Professor in Department of Clinical Nutrition, Faculty of Medicine, Hasanuddin University, Makassar, South Sulawesi, Indonesia.

**Fourth Author** - Rosdiana Natsir, Professor in Department of Biochemistry, Faculty of Medicine, Hasanuddin University, Makassar, South Sulawesi, Indonesia.

**Correspondent Author** - M. Ishaq Iskandar, Email: khansa\_16@yahoo.co.id. Handphone: +628124143216.

# Prevalence and seasonal occurrence of gastrointestinal parasites in small ruminants of coastal areas of TamilNadu.

A. Varadharajan and R. Vijayalakshmi

Division of Animal Husbandry, Faculty of Agriculture, Annamalai University, Annamalai Nagar – 608 002.Tamil Nadu, India.

**Abstract-** The study was carried out from October 2013 to September 2014 in both organised and small sheep and goat farms of coastal areas viz. Cuddalore, Nagapattinam of Tamil Nadu, India. The objective of the present study is to determine the prevalence and seasonal variation of gastrointestinal parasites in small ruminants. A total of 1356 faecal samples (63 from goat and 50 from sheep per month) were collected and subjected for analysis. Among the analysed samples 61.50% were positive for endoparasites. The prevalence of gastrointestinal parasites was higher in sheep (66.33%) than in goats (57.67%). The endoparasites found in small ruminants were nematodes, cestodes and trematodes. The nematode *Haemonchus sp* was found to be predominant in both sheep and goat. The results of season wise analysis indicates that the overall infection percentage was higher in rainy season (68.36%) followed by winter (60.84%) than in summer (55.30%).

**Index Terms-** prevalence, seasonal variation, gastrointestinal parasites, small ruminants, Tamil Nadu

## I. INTRODUCTION

Small ruminants are widely distributed and are of great importance as a major source of income for small and the landless farmers in rural areas. Sheep & goat with large genetic diversity accounts for about 0.5 to 5% of total output of livestock sector in India [1]. Helminthiasis, especially parasitic gastro-enteritis, pose a serious health threat and a limitation to the productivity of small ruminants due to the associated morbidity, mortality, cost of treatment and control measures [2]. In addition to these threats, infestation with helminthes lowers the animal's immunity and renders it more susceptible to other pathogenic infections; finally this may result in heavy economic losses [3].The problem is however much more severe in tropical countries due to very favourable environmental conditions for helminth transmission [4].

Three classes of helminthes are distinguished, namely nematodes (roundworms), cestodes (tapeworms) and trematodes (flukes). Several authors [5-11] have explored various aspects of helminth infestation in small ruminants at different localities of Tamil Nadu and other states of India with a range of 25 - 92%. No report is available on prevalence of gastrointestinal helminthes in south coastal region of Tamil Nadu viz., Cuddalore and Nagapattinam districts where goat farming is the primordial occupation of the small farmers. Hence, the present study was

undertaken to analyse the helminth infestation in small ruminants with appropriate design and effective control measures.

## II. MATERIALS AND METHODS

### 2.1 Study Population

The sheep and goats maintained along the coastal areas of Tamil Nadu viz. Cuddalore and Nagapattinam districts by the organized farms, small and marginal farmers were selected for the study. Four flocks of goat, five flocks of sheep, each flock with 15 – 20 animals, 45 goats reared under semi-intensive system and goats maintained at division of Animal Husbandry, Faculty of Agriculture, Annamalai University were selected for the study. Depending on the climatic condition the animals were allowed for grazing of 5-8 hrs per day.

### 2.2 Collection and examination of Faecal Sample

From October 2013 to September 2014, a total of 1356 fresh faecal samples were collected from the selected sheep and goat flocks. The faecal samples were examined for helminth eggs using Direct, Sedimentation, Floatation techniques [12, 13].

## III. RESULTS AND DISCUSSION

The analysis of faecal samples revealed that among the 1356 samples examined, 834 were found positive for helminth infection with an overall prevalence of 61.5 percent (Table. 1 and Figure. 1). The flock wise analysis of helminth infection was given in Fig. 1 which showed sheep flock was most affected than the goat flock. The results of species wise analysis of faecal samples are shown in Table. 2 and Figure.2. From the table it was noted that both sheep and goat flocks were affected by nematodes (*Haemonchus sp*, *Trichuris sp* and *Strongyloides sp*), cestodes (*Monizia sp*) and trematodes (*Amphistomes* and *Fasciola sp*). It was found evident that *Haemonchus sp* was the dominant species affecting both sheep and goat flocks. Next to it, the animals were affected with the trematode *Amphistomes*. The results of season wise infection of helminthes in both sheep and goat flocks are summarized in Table. 3 and figure.3. Out of three seasons, higher percentage of infection was detected during rainy season (68.36%) followed by winter (60.84%). However, during summer infection was moderate in both goat and sheep flocks (55.30%). The season wise infection percentage for different seasons was displayed in Fig. 3. As shown in figure, sheep flock has witnessed highest infection percentage than goat for all the three seasons.



The present study indicated that the infection with gastrointestinal helminthes is a frequent phenomenon among the small ruminants of coastal districts of Tamil Nadu, India. The higher incidence of parasites in different study areas of Tamil Nadu were reported by many researchers [7, 8, 14, and 15]. The observed results were also in agreement with the findings of various authors from other parts of India [9, 10, 11, 16, 17].

The various species of parasites recorded in the present study coincided with the findings of various authors [18, 19, 15].

The seasonal occurrence of parasitic infection in small ruminants depicted higher infection of helminthes in rainy season followed by winter than in summer. This is in accordance with findings of other researchers [5, 20]. Heavy rainfall and high relative humidity predisposed to heavy parasitic infection [21]. Climatic factors also influenced dispersion of larvae in the herbage which increased the chance of contact between host and larvae [22, 23]. Higher infection during rainy season may also be attributed to suitable molarity of salt present in soil, an important factor for ecdysis [24].

#### IV. CONCLUSION

From the above findings it was observed that the infections of gastrointestinal parasites among small ruminants were most prevalent throughout the year in organized and small holding flocks in varying intensity. Hence, appropriate strategic treatment with broad spectrum anthelmintic should be practised during the start and end of rainy season. Such treatment regime is strategic to get rid of the parasitic burden in the small ruminants and also minimize the pasture contamination by reducing faecal egg counts.

#### ACKNOWLEDGEMENT

The authors are thankful to the Authorities of the University for the Facilities provided, the sheep and goat farmers for collection of samples and the staff of Division of Animal Husbandry for their cooperation in examination of samples.

#### REFERENCES

- [1] Singh, K. 1995. Livestock research and production in South Asia. Proceedings of a Consultation on Global Agenda for Livestock Research. Nairobi, International Livestock Research Institute. 41-48.
- [2] Nwosu, C. O., Madu, P. P. and Richards, W. S. 2007. Prevalence and seasonal changes in the population of gastrointestinal nematodes of small ruminants in the semi-arid zone of North-Eastern Nigeria. *Veterinary Parasitology*.144:118-124.
- [3] Garedaghi, Y., Rezaii-Saber, A.P., Naghizadeh, A and Nazeri, M. 2011. Survey on prevalence of sheep and goats lungworms in Tabriz abattoir, Iran. *Adv. Environ. Bio.* 5:773-775.
- [4] Mohanta, U.K., Anisuzzaman, T., Das, P.M, Majumder, S. and Mondal, M.M.H. 2007. Prevalence, population dynamics and pathological affects of intestinal helminths in Black Bengal goats. *Bangladesh J. Vet. Med.* 5:63-69.
- [5] Katoch, R., Chauhan, P.P. S. and Johri, D.K. 2000. Seasonal incidence of gastrointestinal nematodes in goats of Mathura region. *Indian Vet. J.* 77:259-260.
- [6] Rahman, N. and Ali, A. 2001. Monthwise prevalence of gastrointestinal trematodes, cestodes and nematodes infecting Damani sheep and goats in District D.I.Khan. *Pakistan. Vet. J.* 21:111-113.

- [7] Jeyathilakan, N., Radha, G., Gomathinayagam, S and Lalitha John. 2003. Emergence of anthelmintic resistance in nematodes of sheep in Tamil Nadu. *J. Vet. Parasitol.* 17:159-160.
- [8] Easwaran, S. 2004. Anthelmintic resistance in gastrointestinal nematodes of sheep and goats. M.V.Sc., thesis submitted to Tamil Nadu Veterinary and Animal Sciences University, Chennai-51.
- [9] Singh, H., Rai, H. S., Singh N. K. and Kaur, A. 2005. Prevalence of helminthic infection in sheep in Ludhiana. *J. Vet. Parasitol.* 19:97-101.
- [10] Mamatha, G.S and Placid E. D' Souza. 2007. Gastrointestinal parasitism in sheep and goats from different districts of Karnataka. *Intas Polivet.* 8:112-114.
- [11] Kuchai, J.A., Chshti, M.Z., Zaki, M.M., Ahmad, J., Rasool, M., Dar, S.A. and Tak, H. (2011) Epidemiology of helminth parasites in small ruminants of Ladakh, India. *Online J. Ani. Feed Res.* 5:239-242.
- [12] Foriet, W. 1999. In: Reference Manual of Veterinary Parasitology. 5th (ed). Wiley Blackwell, New York, USA. 22-26.
- [13] Kassai, T., 1999. *Veterinary Helminthology*. Butterworth-Heinemann, Reed Educational and Professional Publishing Ltd., Oxford, USA. 260.
- [14] Meenakshisundaram. 1999. Anthelmintic resistance in gastrointestinal nematodes of sheep. M.V.Sc., thesis submitted to Tamil Nadu Veterinary and Animal Sciences University, Chennai-51.
- [15] Palanivel, K. M., Rishikesavan, R., Sureshkumar, K and Gopi, H. (2012) Epidemiology of parasitic infection in madras red sheep in Tamil Nadu. *Intl J. Food Agri. Vet. Sci.* 2 (3):140-145.
- [16] Padmaja, K., Haritha, C and Anitha, K. 2007. Prevalence of gastrointestinal parasitism in goats. *Intas Polivet.* 8:32-34.
- [17] Bandyopadhyay, S., Devi, P., Bera, A., Bandyopadhyay, S and Bhattacharya, D. 2010. Prevalence of Gastrointestinal Parasite in Goats in Shillong, Meghalaya, India, *WebmedCentral PARASITOLOGY* 1(9):WMC00777.
- [18] Kanyari, P.W.N., Kagira, J.M and Mhoma, R.J. 2009. Prevalence and intensity of endoparasites in small ruminants kept by farmers in Kisumu Municipality, Kenya. *Livestock Research for Rural Development.* 21:1-10.
- [19] Gadahi, J.A., Arshad, M.J., Ali, Q., Javaid, S.B and Shah, S.I. 2009. Prevalence of gastrointestinal parasites of sheep and goats in and around Rawalpindi, Islamabad. *Veterinary World.* 2:51-53.
- [20] Yadav, A.J.K., Khajuria, J.K and Raina, A. K. 2006. Seasonal prevalence of gastrointestinal parasites of sheep and goats of Jammu. *J. Vet. Parasitol.* 20(1):65-68.
- [21] Hawkins, P.A., 1945. Studies of sheep parasites VI. Observations on weather in relation to untreated nematode infections. *J. Parasitol.* 31:17.
- [22] Ogbourne, C.P. 1972. Observation on the free-living stages of strongylid nematodes of horses. *Parasitology.* 64:461-477.
- [23] Croll, N.A. 1975. Behavioural analysis of nematode movement. *Adv. Parasitol.*, 13:113.
- [24] Soulsby, E.J.L. 1966. *Biology of Parasites*. Academic Press, New York and London. 185-196.

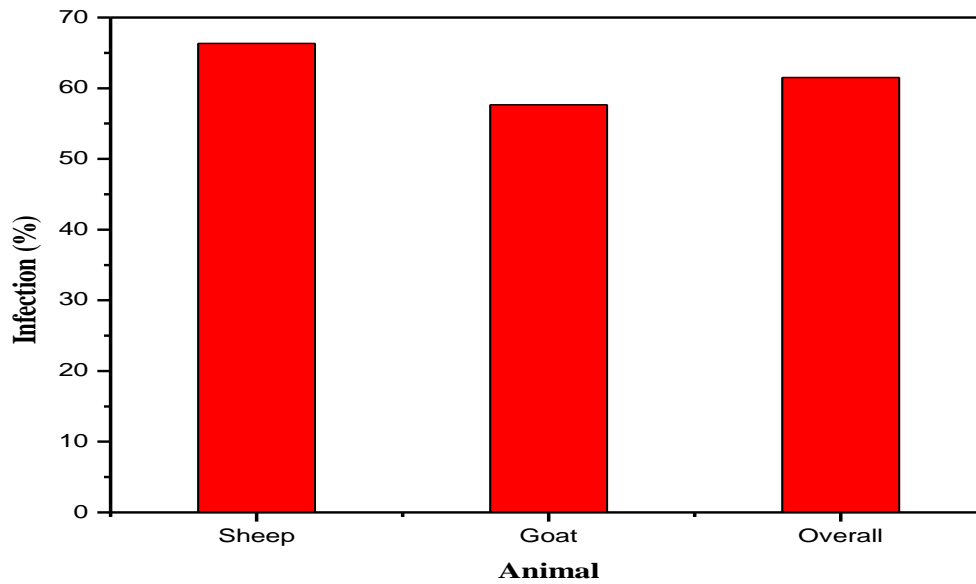
#### AUTHORS

**First Author** – A. Varadharajan, Division of Animal Husbandry, Faculty of Agriculture, Annamalai University, Annamalai Nagar – 608 002. Tamil Nadu, India.

**Second Author** – R. Vijayalakshmi, Division of Animal Husbandry, Faculty of Agriculture, Annamalai University, Annamalai Nagar – 608 002. Tamil Nadu, India.

**Table. 1 The flock wise analysis of helminth infection**

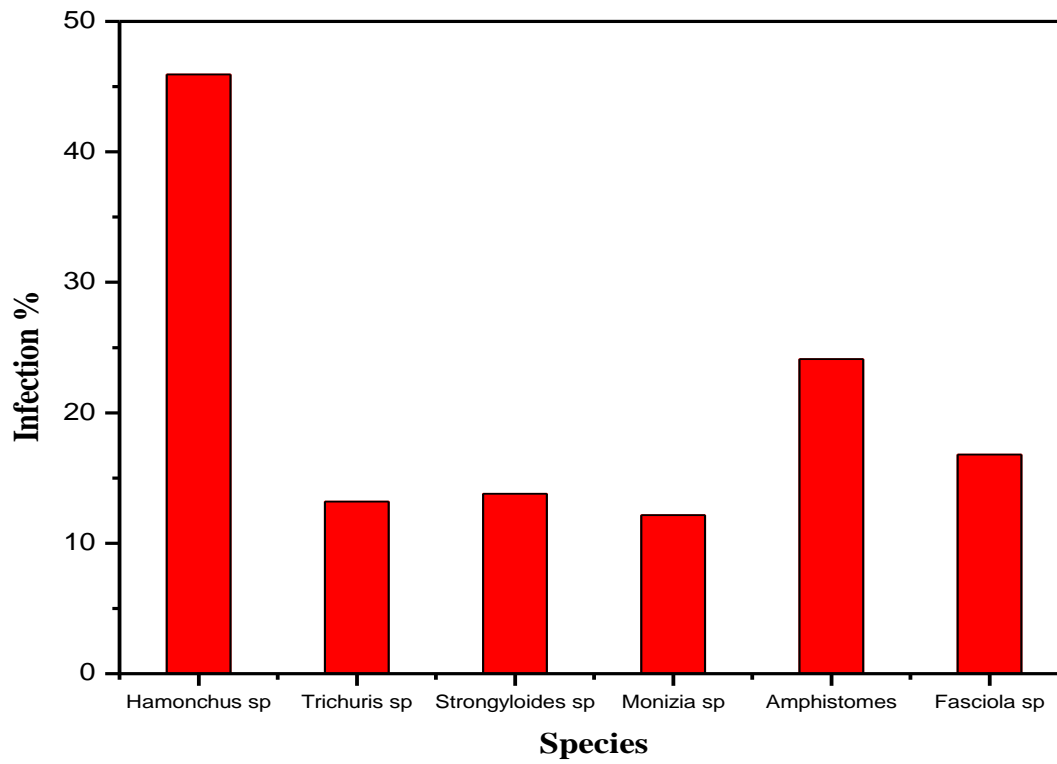
Animal	No.of samples collected	No.found positive	Infection (%)
Sheep	600	398	66.33
Goat	756	436	57.67
Overall	1356	834	61.50



**Fig. 1 The flock wise analysis of helminth infection**

**Table.2. Species wise prevalence of gastrointestinal helminthes in sheep and goats**

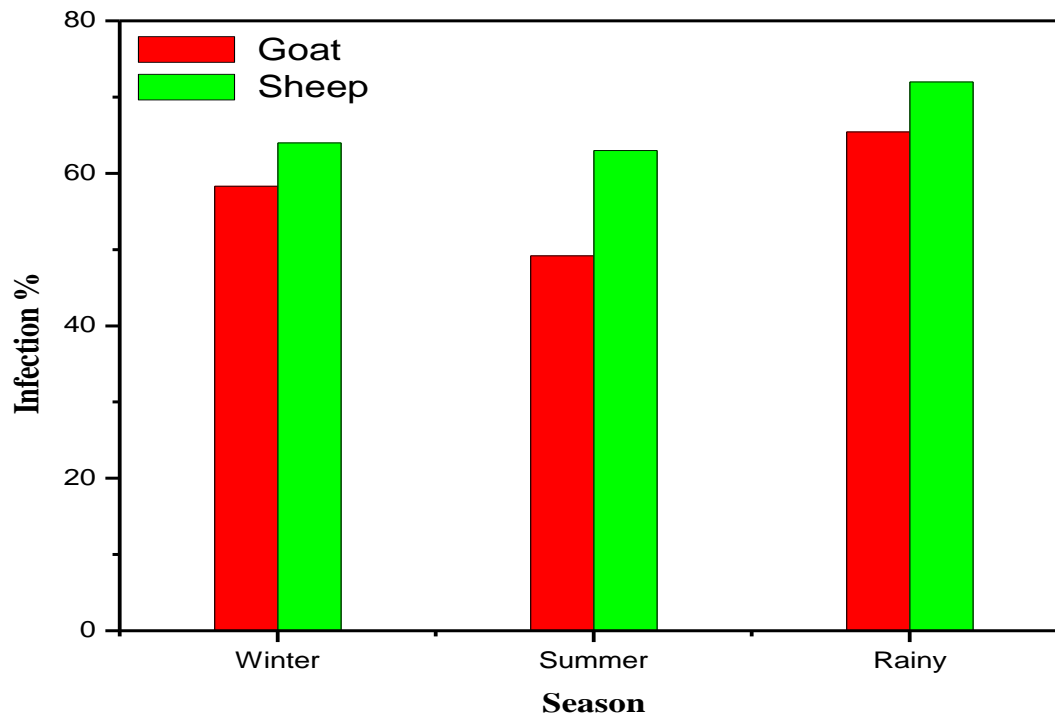
Sl.No.	Species	No.of animals examined	Total positive	Infection percentage
1	<i>Haemonchus sp</i>	1356	623	45.94
2	<i>Trichuris sp</i>	1356	179	13.20
3	<i>Strongyloides sp</i>	1356	187	13.79
4	<i>Monizia sp</i>	1356	165	12.16
5	Amphistomes	1356	327	24.11
6	<i>Fasciola sp</i>	1356	228	16.80



**Fig. 2 Species wise prevalence of gastrointestinal helminthes in sheep and goats**

**Table. 3 Season wise occurrence of helminth infection in small ruminants**

Season	Goat			Sheep			Both		
	No.of samples collected	No.found positive	Infection (%)	No.of samples collected	No.found positive	Infection (%)	No.of samples collected	No.found positive	Infection (%)
Winter	252	147	58.33	200	128	64.00	452	275	60.84
Summer	252	124	49.20	200	126	63.00	452	250	55.30
Rainy	252	165	65.47	200	144	72.00	452	309	68.36



**Fig. 3 Season wise occurrence of helminth infection in small ruminants**

# A Newborn with Epidermolysis Bullosa

R.Prasanna, S.Subash

Department of Pediatrics, SRM Medical College Hospital and Research Centre, Kattankulathur, Chennai.

**Abstract-** Bullous disorders of newborn are a rare entity. Genetically inherited bullous disorders, especially the dystrophic and junctional types have a fatal course (1). Breach of the epidermis in the newborn predisposes them to sepsis.

**Index Terms-** epidermolysis bullosa, simplex, junctional, dystrophic.

## I. CASE REPORT

**B**aby born to third degree consanguinous parentage had a normal birth history. Immediately after birth, a small raw area of skin 2 x 2 cms was noted in the left foot. Baby was admitted in Neonatal Intensive Care Unit for observation. Within, 6 hours of birth, small bullae were noticed in the cheek. In the next 24 hours, large flaccid bullae developed in the right elbow and heel of right foot. The bullae contained clear fluid and ruptured off with minimal friction leaving large areas of raw skin exposed. The earliest lesions started healing with scarring.

The lesions relentlessly progressed to involve most of the body area, mostly involving the periorificial areas and the extremities, healing with scarring and contracture formation with tightening and narrowing of oral orifice, contracture of elbows and knees.

Child was started on intravenous antibiotics cefotaxime and amikacin and later changed to vancomycin and meropenam .

Dermatologist opinion was obtained and an opinion of epidermolysis bullosa was given.

Cultures from skin and blood were taken. Skin biopsy for electron microscopy and immunofluorescence testing could not be done due to poor general condition of the newborn baby. Adequate feeding, intravenous fluids for hydration, topical antibiotics and emollients for hydration of skin were instituted. Baby developed features of sepsis by day 7 of life. Appropriate antibiotics were started and revised following culture sensitivity report. In spite of antibiotics, baby died of fulminant staphylococcal sepsis by day 32 of life.

## II. DISCUSSION

Epidermolysis bullosa refers to a group of inherited disorders characterized by bullos lesions that develop spontaneously or as a result of varying degrees of friction or trauma(2).

E. bullosa may be divided into 3 major inherited forms (simplex, junctional & dystrophic) based on the presence or absence of scarring and skin elements, mode of inheritance, level of skin cleavage(3).

The level of cleavage of simplex variety is within the epidermis and it heals without scarring. Inheritance is Autosomal Dominant and the basic pathology lies with the basal keratinocyte. The junctional variant separates in the Lamina Lucida of dermal epidermal junction and leads to atrophic scarring. Inheritance is AR and basic pathology is with the hemidesmosomes. Dystrophic variant has blister formation in papillary dermis, below the basement membrane. Both AD and AR variants are seen and anchoring fibrils are the abnormal.

Overall incidence is 1 in 50,000 live births(4).

## III. SIMPLEX VARIANT

Blister is seen in areas of trauma due to defective keratin filaments and heals without scarring. Major forms are weber-cockayne disease (localized), Koche variant (generalized), Dowling-meara variant (e.bullosa simplex herpetiformis).

Localized variant has a high threshold for frictional trauma, bullae are confined to hand and feet, seen first in hand and feet, hyperhidrosis is present, lesions heal without scarring(5).

Koebner variant has generalized blistering of skin, most notable in sites of friction. There is extensive blistering in neonatal period and early infancy. There is increased risk of sepsis which could be life threatening. Blistering improves with advancing age. Hyperhidrosis is common and mucosa is mildly affected, nails are not affected. Moderate hyperkeratosis of palms and soles are seen.

Dowling meara variant is the most severe form of simplex which is a differential diagnosis for severe dystrophic or junctional forms, but with overall good prognosis. Small characteristic blisters may be seen in the neonatal period on proximal extremities. Blistering decreases by advancing age and hyperkeratosis increases. Extensive blistering could be life threatening due to sepsis(6).

## IV. JUNCTIONAL VARIANT

Cleavage plane is in the lamina lucida at dermo epidermal junction.

Herlitz variant is a lethal variant with 50% mortality within 2 yrs. There is perioral granulation tissue with sparing of lips. Blisters heal with atrophy but no milia. Periungual blistering and erosions are seen, onychia, dental enamel dysplasia and anemia might be seen.

Non – Herlitz variant is less severe with less mucosal involvement.

Other types are the GABEB type, inversa and e.bullosa associated with pyloric stenosis or muscular dystrophy(7).



## V. DYSTROPHIC VARIANT

Divided into Dominant and Recessive forms.

The autosomal dominant variant has its onset at birth. Blistering predominates on dorsum of hands, elbows, knees and lower limbs. This heals with scarring with milia formation. Nail dystrophy is associated.

Recessive form is present at birth with widespread blistering, scarring and milia formation. Deformities like digital fusion and joint contractures are seen. There is severe involvement of mucous membrane and nails. Growth retardation, poor nutritional status and anemia are seen. There are teeth abnormalities. Predisposition to squamous cell carcinoma is present in the heavily scarred areas.

Hallopea-Siemes type, a severe life threatening autosomal recessive type of dystrophic e. bullosa is seen with widespread dystrophic scarring, deformities and severe involvement of mucous membranes. Bullae occur at site of friction. Bullae may be hemorrhagic and lower extremities may be completely devoid of skin. When blister ruptures, raw painful surface is evident. Nikolsky sign is positive. Atrophic scars with milia formation are seen. There is hyperhidrosis and hyperkeratosis. Acquired pseudosyndactyly- claw hand or mitten hand deformities are seen. Fixed flexion deformities of elbows and knees with contractures occur. Bullae, initially sterile, get eventually infected with pseudomonas or staphylococcus which leads to septicemia.

## VI. DIAGNOSIS

Skin biopsy for light microscopy does not provide any clue regarding the variant of e. bullosa.

Electron microscopy is the standard criterion for determining the level of blistering. EM can provide additional information on BMZ morphology that can be helpful in differentiating the different types. Immunofluorescence study and Immunomapping with antibodies to a hemidesmosomal antigen, BP230 and antibody to lamina densa protein (ex. type IV collagen) can

distinguish epidermolysis bullosa simplex, junctional epidermolysis bullosa, and dystrophic epidermolysis bullosa.

Once the mutations are identified in a family, reliable prenatal diagnosis is possible(8,9,10).

Extensive areas of denuded skin represent loss of the stratum corneum barrier to microbial penetration. Accumulation of serum and moisture on the surface enhances the growth of bacteria.

Patients with severe epidermolysis bullosa subtypes may have immunologic abnormalities, including decreased lymphocyte production or a poor nutritional status that lowers resistance to infections. *Staphylococcus aureus* and *Streptococcus pyogenes* are the usual causative organisms, but gram-negative infections with bacteria, such as *Pseudomonas aeruginosa*, also can occur. Patients also have increased susceptibility to developing sepsis.

## VII. TREATMENT

Parents are to be informed of risk of transmitting genetic abnormalities. Genetic counseling is given. Prenatal diagnosis for future pregnancy can be done if the genetic abnormality in the family is identified. Treatment of e. bullosa is mainly palliative. Avoidance of trauma, friction or pressure, Cool environment is preferred. Prevention of infection is the preferred strategy. With extensive areas of crusting and denudation, a strict wound care regimen should be followed. The wound should be covered with semi occlusive nonadherent dressings. Self-adhering gauze or tape is a better choice for keeping dressings in place. Topical mupirocin is drug of choice. Appropriate parental antibiotics should be started when necessary.

## VIII. CONCLUSION

Epidermolysis bullosa are blistering skin disorders. Course of the disease varies according to the level at which blistering occurs in the skin. Septicemia is the cause of death in most of these cases.

Figure1



#### REFERENCES

- [1] Fine JD. Inherited epidermolysis bullosa: past, present, and future. *Ann N Y Acad Sci.* Apr 2010;1194:213-22.
- [2] Sawamura D, Nakano H, Matsuzaki Y. Overview of epidermolysis bullosa. *J Dermatol.* Mar 2010;37(3):214-9.
- [3] Fine JD, Eady RA, Bauer EA, et al. The classification of inherited epidermolysis bullosa (EB): Report of the Third International Consensus Meeting on Diagnosis and Classification of EB. *J Am Acad Dermatol.* Jun 2008;58(6):931-50.
- [4] McGrath JA, Mellerio JE. Epidermolysis bullosa. *Br J Hosp Med (Lond).* Apr 2006;67(4):188-91.
- [5] Fine JD, Bauer EA, McGuire J, Moshell A, eds. *Epidermolysis Bullosa: Clinical, Epidemiologic, and Laboratory Advances and the Findings of the National Epidermolysis Bullosa Registry.* Baltimore, Md: Johns Hopkins University Press; 1999.
- [6] Risser J, Lewis K, Weinstock MA. Mortality of bullous skin disorders from 1979 through 2002 in the United States. *Arch Dermatol.* Sep 2009;145(9):1005-8.
- [7] Ersoy-Evans S, Erkin G, Fassihi H, et al. Ectodermal dysplasia-skin fragility syndrome resulting from a new homozygous mutation, 888delC, in the desmosomal protein plakophilin 1. *J Am Acad Dermatol.* Jul 2006;55(1):157-61.
- [8] Fassihi H, Eady RA, Mellerio JE, et al. Prenatal diagnosis for severe inherited skin disorders: 25 years' experience. *Br J Dermatol.* Jan 2006;154(1):106-13.
- [9] Fassihi H, Eady RA, Mellerio JE, et al. Prenatal diagnosis for severe inherited skin disorders: 25 years' experience. *Br J Dermatol.* Jan 2006;154(1):106-13.
- [10] Heagerty AH, Eady RA, Kennedy AR, et al. Rapid prenatal diagnosis of epidermolysis bullosa letalis using GB3 monoclonal antibody. *Br J Dermatol.* Sep 1987;117(3):271-5.

#### AUTHORS

**First Author** – R.PRASANNA ,DCH,DNB ,ASSISSTANT PROFESSOR , Department of Pediatrics, SRM Medical College Hospital and Research Centre, Kattankulathur, Chennai.

**Second Author** – S.SUBASH ,MD, PROFESSOR, Department of Pediatrics, SRM Medical College Hospital and Research Centre, Kattankulathur, Chennai.

# Unusual Foreign Body in the Mastoid

Dr. P. K. Purushothaman, Dr. C.R.K. Balaji, Dr Sonia Sera Thomas

SRM Medical College Hospital and Research Center

**Abstract-** We report a case of a girl who was assaulted by her brother with a large stainless steel spoon which was found penetrating the mastoid cortex. There were no signs of intracranial bleeding. CT brain revealed the metallic part of the spoon piecing the mastoid cortex and compressing the sigmoid sinus. Under general anaesthesia spoon was removed in the operation theatre. Post operatively recovery was uneventful.

**Index Terms-** Foreign body, Sigmoid sinus, Mastoid cortex, Facial nerve, CT brain.

## I. INTRODUCTION

Penetrating wounds of the head and neck are rare and potentially life-threatening injuries. The severity and extent of such injuries depend on the weapon used and the anatomic site involved. The risk of vascular, neurological, eye, and ear injuries is particularly high. The management of such patients receives

considerable attention, as it can be seen from the reports published so far. We describe the management and recovery of the patient with an injury to the mastoid region by a big spoon. The treatment of the wound required multidisciplinary approach.

## II. CASE REPORT

A 17year old female, came with alleged history of assault by her brother using a big stainless steel spoon. She came to the casualty with the spoon penetrating the left mastoid region. She presented with pain and minimal bleeding at the site of injury. The patient was conscious and well oriented.

No h/o ear bleeding and nasal bleeding.

No h/o seizures

No h/o giddiness, hard of hearing.

She attempted to remove the spoon by herself but did not succeed.



**Figure 1:** showing metallic part of spoon piercing the mastoid cortex.

The Glasgow coma scale was 15. On clinical examination the foreign body was seen penetrating the left mastoid region. The length of the object seen outside was 14cm. CT brain was taken which revealed the metallic part of spoon piercing the mastoid cortex. Otorhinolaryngological examination revealed

bilateral external auditory canal was normal, tympanic membrane intact with hearing within normal limits clinically.

Facial nerve clinically intact bilaterally.

Mild tenderness over the mastoid was present.

Physical and neurological examination was normal.



**Figure 2: CT brain showing metallic part of the spoon piercing the mastoid cortex.**

The patient was taken up as emergency in operation theatre. Under general anaesthesia, post auricular incision was made and subcutaneous tissue elevated. Mastoid cortex identified after elevating the periosteum. Foreign body was seen firmly penetrated and fixed to the mastoid cortex. Drilling was started around the foreign body and was found penetrating the sinus plate compressing the sigmoid sinus. After complete drilling over the mastoid and the foreign body, it was removed in toto. Gel foam and surgical placed. Haemostasis secured and wound closed in layers. Post-operative recovery was uneventful. Facial nerve was intact post operatively. The length penetrating inside was 1.75cm and penetrated part was found to be blunt. CT brain taken post operatively showed subcutaneous air pockets with fracture of mastoid part of the left temporal bone. Audiometry done showed hearing within normal limits.

### III. DISCUSSION

The interest in reporting the case was the style of trauma and part of the spoon which was penetrating the mastoid cortex was blunt. The force was so tremendous to pierce the mastoid cortex and compressing the sigmoid sinus. The foreign body which was radio opaque was easily visible in CT brain. Craniofacial stab injuries are termed as Jael's syndrome. It is defined as deliberately inflicted penetrating injuries of the maxillofacial region. Stab wounds to the mastoid region are an unusual variant<sup>1</sup>. Reviewing various literatures, a similar case of blunt injury of the mastoid region without any other associated vascular or endocranial injuries had been reported.

GURTU et al<sup>2</sup> (1997) reported a case of unusual foreign body piercing mastoid process (metallic end of refill of dot pen). The pointed end of the refill pierced through and through the pinna and entered in to the mastoid process. An incision around 3mm was made around the point of entry of foreign body. Burr was used to drill the bone around the foreign body and the same was removed. Col Lt H Vijayanand<sup>3</sup> reported a case of foreign body mastoid with discharging post aural sinus. Cortical mastoidectomy was done and foreign body was removed in toto. Post operatively the patient developed clinical features of sigmoid sinus thrombosis. High dose antibiotics was given and was treated conservatively. The patient had an uneventful recovery.

Hadeishi H et al<sup>4</sup> (1955) reported a study (mastoid canal and migrated bone wax) in which they have concluded that intrasurgical application of a large quantity of bone wax to control venous bleeding from the mastoid emissary veins carries a risk of migration of bone wax in to sigmoid sinus. Cholesterol granuloma coincidence with a large and high jugular bulb has been reported by Kasemsuwan<sup>5</sup> (1993).

The vital anatomical relations of the mastoid air cells are middle fossa meninges superiorly, labyrinth medially, facial nerve anteriorly and sigmoid sinus posteriorly. Possible complications include meningitis, sigmoid sinus thrombosis, mastoiditis, facial nerve palsy and labyrinthitis. However due to immediate intervention and postoperative care our patient had no complications.

### REFERENCES

- [1] Ivo Gluncic, ZeljkaRoje. Unusual stab injury of temporal region. *Croat Med J* 2001; 42:579-582
- [2] Gurtu JN, Jha BK. An unusual case of foreign body in the mastoid process. *Ind J Otolaryngol Head and Neck Surgery*. 1997;49:160-1.
- [3] Col Lt H Vijayanand, Lt Col S Chaudhury. Foreign body mastoid. *MJAFI* 2000;56:349-350
- [4] Hadeishi H; Yasui -N; Suzuki-A. Mastoid canal and migrated bone wax in the sigmoid sinus. *Neurosurgery* 1955; June 1220-3.
- [5] Kasemsuwan L, Jenjitraut J, Congsusuek P. Cholesterol granuloma coincidence with a large and high jugular bulb- report of a case. *J Med Assoc Thai*. 1993 May; 76(5): 296-302.

### AUTHORS

**First Author** – Dr P K Purushothaman, MS, Professor, Department Of ENT, SRM Medical College Hospital and Research Centre, entpurush@gmail.com.

**Second Author** – Dr C R K Balaji MS, Assistant Professor, Department Of ENT, SRM Medical College Hospital and Research Centre, crk\_balaji@yahoo.co.in.

**Third Author** – Dr Sonia Sera Thomas, Final Year Post Graduate, Department Of ENT, SRM Medical College Hospital and Research Centre, soniaserathomas@gmail.com.

**Correspondence Author** – Dr P K Purushothaman, MS, Professor, Department Of ENT, SRM Medical College Hospital and Research Centre, entpurush@gmail.com. Ph: 9840723243.

# Unit Rectangle Visibility Representation of Binary and Ternary Tree

Mehnuma Tabassum Omar, Kamrun Naher, Monika Gope and Ummay Asma

Department of Computer Science and Engineering  
Khulna University of Engineering & Technology (KUET)  
Khulna 9203, Bangladesh.

**Abstract:** The Visibility Representations [1] of a graph has been promoted for research extensively because of their significance in algorithmic graph theory as well as in VLSI layout, algorithm animation, visual languages and CASE tools etc. [2][3]. Rectangle Visibility Graph (RVG) used in VLSI chip design represents the node of a graph as a rectangle in a plane. Unit Rectangle Visibility Graph (URVG) means a presentation where each node is represented as unit rectangle in the plane. So, Unit Rectangle Visibility graph is applied for fixed dimensions of gates and various circuit components in computer chip applications. In this research, binary tree and ternary tree have been characterized as URV representations which will not only enhance URVR (Unit Rectangle Visibility Representation) but also expected to reduce both cost and labor in the field of various graph applications. To achieve this, two novel algorithms for URVR of these trees have been proposed.

**Keywords:** Visibility Representation, Unit Rectangle Visibility Graph, flush, caterpillar, spine.

## I. INTRODUCTION

The representations of graph have been analyzed exclusively due to their intentions to be applied in numerous visibility applications. One of the representations is to employ geometric entity to depict a graph entity. This initiative has been inspired by the diversity of practical significances and the potentiality of interchange between geometry, graph theory and other mathematical area [4]. The Visibility Representation of graph is one of the natural strategies of representing graph using geometric aspects [5]. The determination of Visibility Representation (VR) of a graph has been studied widely because of their large number of applications such as in VLSI design, CASE tools, hidden surface elimination problem, layout problem [6].

Visibility Representation or VR demonstrates the vertices of a graph as horizontal vertex- segments, and the edge as vertical edge-segment. The edge maintains its end vertices by touching their corresponding segments without intersecting the segments beyond that. In before, for large number of applications and layout problems have motivated the study of Bar Visibility Graph (BVG) and Rectangle Visibility Graphs (RVGs) which is a two-dimensional counterpart of BVG [7].

Bar visibility graph (BVG) is one in which each vertex of a graph is determined by a horizontal bar and edges by unobstructed vertical visibilities between the corresponding bars. The adjacent vertices are presented by adjacent bars. The

adjacent bars are depicted by a vertical band positive width that intersects no other bars [6]. A Unit Bar Visibility Graphs (UBVGs) is a BVG having bars of unit length.

In a Rectangle Visibility Graph (RVG) the vertices of a graph is resolved by closed rectangles in a plane and edges by unobstructed horizontal or vertical visibilities between the corresponding rectangles. The sides of the rectangles are parallel to the axes pair wise disjoint except possibly for overlapping boundaries, in such a way that two vertices are adjacent if and only if each of the corresponding rectangles is vertically or horizontally visible from the other [7]. The BVG and RVG are applicable in VLSI chip design and layout problems.

A Unit Rectangle Visibility Graph (URVG) is a RVG having rectangles of unit squares. In BVG and RVG the extent of bars and rectangles respectively may have diverse dimensions. But there are some constraints in the area and aspect ratio for the component of a chip [8]. The URVG maintains unit squares in its rectangles and for this reason it preserves a fixed area and fixed aspect ratio. So, in chip design, URVG achieves popularity than the other representations. URVG converts a graph into a model that is more precise to the subject [7]. It is also efficient in designing computer chips having huge number of logical gates with complicated wiring and timing constraints.

This paper describes the Unit Rectangle Visibility Trees (URVR) of a graph where each vertex can take place and satisfy all of the Unit Rectangle Visibility Representation conditions. The presentation is dedicated explicitly on binary tree and ternary tree and developed two algorithms for these trees.

The paper is organized in six sections. In section II the URVG representation is described briefly. Section III will discuss related works so far been performed for the presentation of graph. The proposed methodologies are described in section IV. Finally section V will conclude this paper.

## II. THE UNIT RECTANGLE VISIBILITY GRAPH

The function of RVG is to transform nodes of a graph to some rectangles. URVG is an extension of RVG. It restricts the rectangles to be arranged in unit squares so that it can form more subjective applications.

Fig. 1 shows an example of a graph with its URV layout. The square in the URV layout corresponding to a vertex  $v$  is symbolized by  $S_v$  [7]. The placement of the square  $S_v$  in a



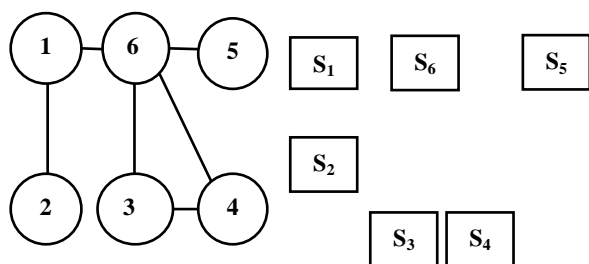


Figure 1: A graph with a URV layout

URV layout is performed by the bottom-left corner coordinates  $(x_v, y_v)$  of the URV layout. In this layout,  $X_v$  is a line segment given by the intersection of the line  $x = x_v$  with the square  $S_v$ , and  $Y_v$  is a line segment given by the intersection of the line  $y = y_v$  with the square  $S_v$ . The  $S_v$  and  $S_w$  will be entitled as a flush if the co-ordinate  $x_v$  is equal to the co-ordinate  $x_w$  or the co-ordinate  $y_v$  is equal to the co-ordinate  $y_w$ . But flush does not prohibit the other squares in the layout to hamper the visibility between  $S_v$  and  $S_w$ . A flush will be defined as a horizontal flush if the coordinates  $X_{S_v}$  and  $X_{S_w}$  are equal. A vertical flush is a flush where the coordinates  $Y_{S_v}$  and  $Y_{S_w}$  are equal. In the given layout depict in Fig. 1, the squares  $S_2$  and  $S_3$  are collinear but not flush while the squares  $S_1$  and  $S_2$  and the squares  $S_1$ ,  $S_5$ , and  $S_6$  are flushes.

## Related Works

The VR representation of a graph is a geometrical presentation in the arena of graph which is very popular of being relevant in the implementation of VLSI layout [9]. The significance of VR is so fascinating that it keeps recognition of several researchers [9] [10]. This section will refer to some of the variants of VR viewing different significant applications.

In [11] they claimed a VR as an augmentation of tessellation representation. According to this consequence the general dilemma with most implementations of the various tessellation representations are robustness as it identifies the surfaces as edges. If topology information is overlooked during the tessellation method, nearby surfaces may have contrary borders and thus do not stick together easily. In [1] to present vertices of a graph, a group of parallel hyper-rectangles in  $R^n$  is provided with the visibility orthogonal to the hyper-rectangles. The non-planner bar k-visibility representation of graph is demonstrated in [12]. [17] Illustrated the area specification of bar visibility representation and rectangle visibility of trees in a plane. The survey of Rectangle Visibility Graphs (RVGs) is very potential in graph-visualization and graph-drawing domains [13]. An extension of RVG is demonstrated in [8] where the RVG presents each vertex of a graph by the rectangles having length of unit squares. The BVG and RVG are failed to meet the requirement of fixed area and fixed size aspect ratio of a computer chip because of their dimension diversity. For this concern [8] deliberated Unit Bar Visibility Graphs (UBVGs) having bars of identical length. A variant of this scheme that utilizes 3-space boxes was considered in [14], [15]. The RVG representation can also be used in tree applications. In [16] the prerequisite of a k-tree to be RVG are narrated. If the range for k is  $1 \leq k \leq 4$  then the tree became a RVG. In [18] a definition for 1-tree to be a URVG is presented. The paper

also summarized that a 4-tree is not a URVG. [19] Emphasizes the ternary URVG presentation. They disclosed

**Input :** Binary tree

**Output :** URVR presentation of binary tree

**Algorithm :**

```

URV_binary_tree(){
    //enter node info
    1. Set position for root at  $x_i, y_i$ .
    2. Find root of current node
        //check node , left or right child of root
    3. if(node==left child)
        //check level, odd or even
        if(level==odd)
            set position at  $\min_x-2, y_i-2/3$ 
        if(level==even)
            set position at  $x_i-2/3, \min_y-2$ 
        find max-min position
    4. if(node==right child)
        //check level, odd or even
        if(level==odd)
            set position at  $\max_x+2, y_i+2/3$ 
        if(level==even)
            set position at  $x_i+2/3, \max_y+2$ 
        find max-min position
    5. increase node value by one
    6. Repeat step 2-5 until node remain
    7. Draw rectangle using position of nodes
    8. Draw node number with rectangles.
}
    
```

Figure 2: Algorithm for URVG representation of a binary tree a little about the binary presentation.

The paper showed that if the decomposition of ternary tree has maximum 4 degree and a union of three caterpillars with additional properties then the presentation is a URVG. A tree where the degree of all vertices on a single path is greater than 1 is named as a caterpillar. If the length of the path is maximal then it is defined as a spine of the caterpillar. But this presentation is not sufficient. In this paper two unique algorithms have been suggested for binary and ternary tree which will enrich the URVR presentation.

## Proposed methodology

A tree is an undirected graph in which any two vertices are connected by exactly one simple path. In other words, any

connected graph without cycles is a tree. A forest is a disjoint union of trees.

A binary tree is a tree data structure in which, each node has at most two child nodes, usually distinguished as “left”

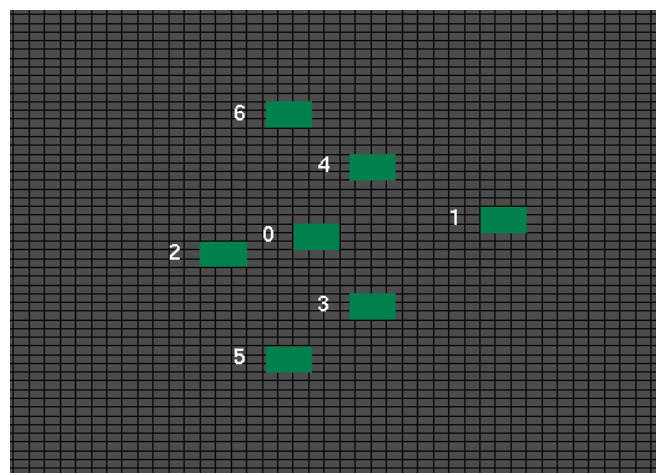
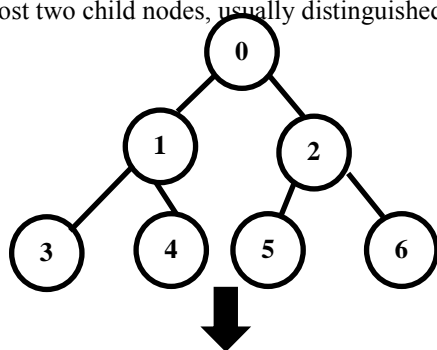


Figure 3: Input and output of URVR binary presentation

and “right”. A tree data structure which has at most three child nodes is called a ternary tree. A node is a structure which may contain a value, a condition, or represent a separate data structure (which could be a tree of its own). Each node in a tree has zero or more child nodes, which are below it in the tree (by convention, trees are drawn growing downwards). A node that has a child is called the child’s parent node. A node has at most one parent. An internal node or inner node is any node of a tree that has child nodes. Similarly, an external node (also known as an outer node, leaf node, or terminal node), is any node that does not have child nodes. The level of a node is defined by the number of connections in the shortest path between node and the root [20].

In this paper two algorithms for URVR of trees have been proposed. The first algorithm works for binary trees and the later one will work for ternary trees. For presenting a tree on URVR, some co-ordinate positions will be required. The root of the tree will be traced by the co-ordinate position  $(x_i, y_i)$ . Some other positions like  $x_m, x_M, y_m, y_M$  will be maintained for minimum x coordinate, maximum x coordinate, minimum y coordinate and maximum y coordinate respectively. The levels of the tree like level0, level1, level2 will be declared by L0, L1 and L2.

#### A. URV Representation of Binary Tree

This section will convert a binary tree to a URVR. This binary tree may be balanced or unbalanced. The proposed algorithm will work for both the balanced and unbalanced tree. First the root will be placed. Then the left child and the right child will be placed accordingly. The algorithm is illustrated in Fig. 2.

The following steps will execute the proposed approach for converting a binary tree to a URVR.

**Input :** Ternary tree

**Output :** URVR presentation of ternary tree

**Algorithm :**

URV\_ternary\_tree() {

1. draw root [0] at initial co-ordinate  $(x,y)$
2. define some points as  
 $D1 = (X_M+3, Y_i+1/4)$   
 $D2 = (X_m-3, Y_i-1/4)$   
 $D3 = (X_i+1/4, Y_M+3)$   
 $D4 = (X_i-1/4, Y_m-3)$

And some pattern as

- P1 = D3, D4, D1  
 P2 = D3, D4, D2  
 P3 = D1, D2, D3  
 P4 = D1, D2, D4

3. draw level-1 nodes 1,2,3 at points D1, D2, D3 considering root=[0] means  $i=0$ ;
4. increment level means  $L=2$  and set  $i=1$  and draw child of  $i$  to looking at its root point  
 If it is D1 then draw pattern P1  
 Else if it is D2 then draw pattern P2  
 Else if it is D3 then draw pattern P3  
 Else if it is D4 then draw pattern P4
5. increment  $i$  and repeat step 4 two more times as each node have 3 child
6. increment level and go to step 4 for drawing next level’s child node
7. repeat step 6 until it reaches the last level

}

Figure 4: Algorithm for URVG representation of a ternary tree

a) *Placing Root* : For depicting a URVR from binary tree, at first the root is placed. Each node is presented by a rectangle which is unit in size. For placing a unit edge the length is maintained equal and the distance is maintained as one unit. The bottom left corner of a rectangle is searched. Then the rectangle is placed the at any arbitrary position,  $x_i, y_i$ .

b) *Placing Left Child, odd level* : Start with left child. As root is the first node, it is on L0. So its child remains at L1. Then the child of L1 is placed at L2 which is an even level. So, as child of root is at L1, that is in odd level, it is placed at position  $(x_m-2, y_i-2/3)$ . The value of  $x_m, x_M, y_m, y_M$  is updated every time after placing each rectangle.

c) *Placing right child, odd level* : Start with right child. It is placed at position  $(x_i-2/3, y_m-2)$ . After placing child it is necessary to check whether it overlaps with other or not.

d) *Placing left child, even level* : Starting with L2, that is, even level. So according to the even level rule, the left node of child one is placed at position  $(x_M+2, y_i+2/3)$ .

e) *Placing right child, even level* : Place right child at  $(x_i+2/3, y_M+2)$ . That is rule for even level right child.

Example 1: The start node is selected as root node and placed at any arbitrary location in URVG layout. The root node is represented at L0 and symbolized as node 0.

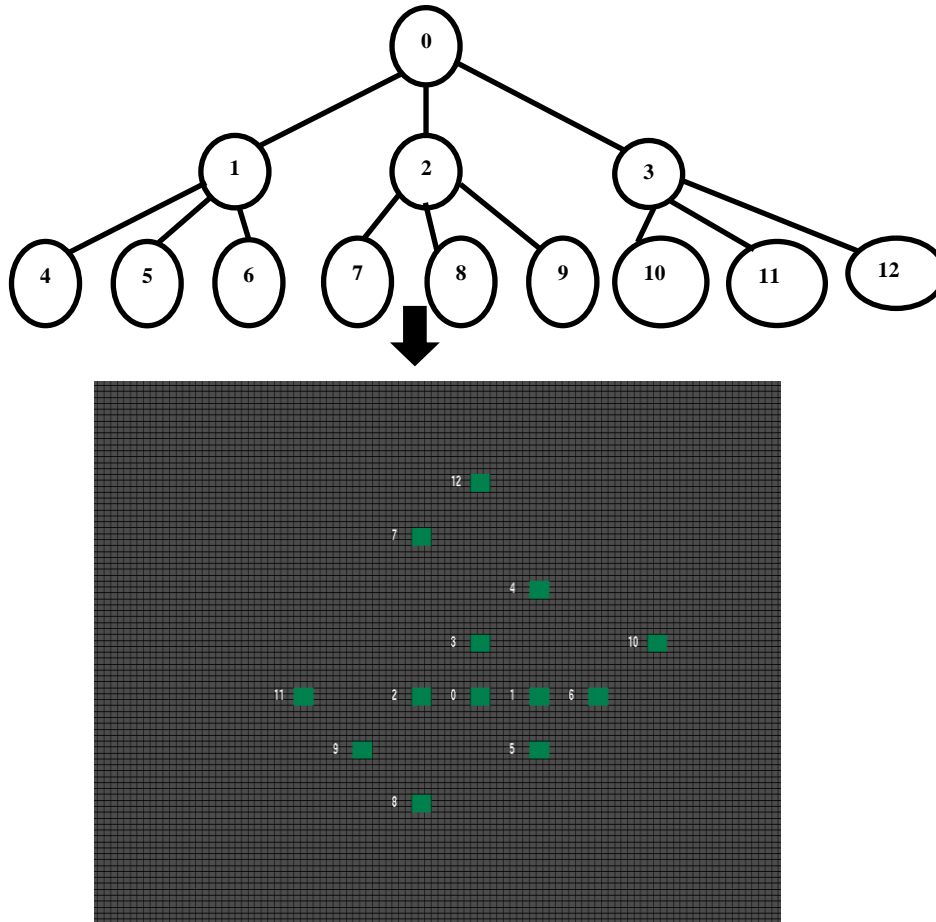


Figure 5: Input and output of URVR ternary presentation

From root node two child nodes are produced entitling as left child and right child. These child nodes are symbolized as node 1 and 2. Node 1 is placed at position  $(X_M+2, Y_i+2/3)$  and 2 is placed at position  $(X_m-2, Y_i-2/3)$ . Update the coordinate value by incrementing the value for  $i$ . From L1 another level known as even level L2 is created. Node 1 produces two child denoted by node 3 and 4 are placed into the URV layout using the even level process. The co-ordinates selected for left child is  $(X_i-2/3, Y_m-2)$  and for right child is  $(X_i+2/3, Y_M+2)$ . Node 2 produces two child node denoted by 5 and 6. The co-ordinates selected for left child or node 5 is  $(X_i-2/3, Y_m-2)$  and for right child or node 6 is  $(X_i+2/3, Y_M+2)$ .

So every level follows this condition properly and without overlapping the square is placed successfully. The above example including input and corresponding output is depicted in Fig. 3

**B. URV Representation of Ternary Tree**

C. This section will convert a ternary tree to a URVR. The idea is to place the root first and then the left child and the right child will be placed accordingly. The algorithm is illustrated in Fig. 4. This ternary tree is restricted to be a balanced tree. The following steps will execute the proposed approach for converting a ternary tree to a URVR.

a) *Placing root* : Each node is presented by a rectangle which is unit in size. For placing a unit edge the length is maintained equal and the distance is maintained as one unit. The bottom left corner of a rectangle is searched. Then the rectangle is placed the at any arbitrary position,  $x_i, y_i$ . Now define some points as  $D1 = (X_M+3, Y_i+1/4), D2 = (X_m-3, Y_i-1/4), D3 = (X_i+1/4, Y_M+3), D4 = (X_i-1/4, Y_m-3)$  and some patterns as  $P1 = D3, D4, D1; P2 = D3, D4, D2; P3 = D1, D2, D3; P4 = D1, D2, D4$ .

b) *Placing childs at L1* : Start with the left child. As root is the first node, it is on L0. So its child remain at L1. The child of L0 is placed at position D1, D2, D3. The first child is placed at position D1 that is at  $(X_M+3, Y_i+1/4)$ , second child

c) at position D2 that is  $(X_m-3, Y_i-1/4)$  and finally the third child at position D3 that is at  $(X_i+1/4, Y_M+3)$ .

d) *Placing childs at L2* : Then child of L1 is placed at L2 that is at even level. As child of root is at L1, that is in odd level, for L2 the position of the parent of L2 is used. If the parent is at D1, then the pattern P1 is used for its three child. That is D3, D4 and D1. If the parent is at position D2, then use pattern P2 that is D3, D4, and D2. If the parent is at position D3, then use pattern P3 that is D1, D2, D3. The value of  $X_m, X_M, Y_m, Y_M$  is updated every time after placing each rectangle.

e) *Placing childs at L3* : At L3 another pattern P4 that is D1, D2, D4 is used because the parent is now at L2 and it can be at position D4 that is  $X_i-1/4, Y_m-3$ . Another patterns are also be used here.

Thus all children at both odd and even level are placed according to the given rules. Here the steps are defined up to L3. The above example including input and corresponding output is depicted in Fig. 5.

**Conclusions**

Chip designing is the key part of chip design model in VLSI design or in fabrication. Visibility Representation is a drawing tool to be used in this purpose. Unit Rectangle Visibility Graph (URVG) arranges each node of a graph as unit rectangle in the plane and gives fixed area and aspect ratio while designing a chip. So Unit Rectangle Visibility Representation is significant in this aspect. The determination of this paper is to define an efficient algorithm for an arbitrary

graph which will increase the performance of UVG and decrease the cost and labor while designing. For this purpose, we have offered two new algorithms, named as URV\_binary\_tree and URV\_ternary\_tree. We have represented the binary tree and ternary tree in a URVR and have accomplished our proposed algorithms successfully. If the graph is large enough, complex, then connection is overlapped to another node. But the existing algorithm works on trees having restriction of degree three. Our proposed algorithm, for ternary tree is implemented for maximum degree four. These proposed algorithms will give a good direction in URV representation.

#### REFERENCES

- [1] F.J. Cobos, J.C. Dana, F. Hurtado, A. M´arquez and F. Mateos, "On a Visibility Representation of Graphs". volume 1027 of Lecture Notes in Computer Science. Springer- Verlag, 1995.
- [2] Huaming Zhang and Xin He, "Improved visibility representation of plane graphs", Computational Geometry 30 (2005) 29–39.
- [3] Ioannis G. Tollis, "Visibility representations of planar graphs (abstract)", ACM SIGACT News Homepage archive Volume 24 Issue 1, Winter 1993 Pages 57-58.
- [4] Stefan Felsner, "Rectangle and Square Representations of Planar Graphs", Partially supported by DFG grant FE-340/7-2 and the EUROGIGA project GraDR.
- [5] Alice M. Deana and Joan P. Hutchinsonb, "Rectangle-visibility representations of bipartite graphs", Discrete Applied Mathematics 75 (1997) 9-25.
- [6] Jiao-Hao Fan, Chun-Cheng Lee, Hsueh-I Lu, Hsu-Chun Yen, "Width-Optimal Visibility Representations of a Plane Graph", Algorithms and Computation: 18<sup>th</sup> International Symposium, ISAAC, 2007.
- [7] Alice M. Dean, Joanna A. Ellis-Monaghan, Sarah Hamilton, Greta Pangborn, "Unit Rectangle Visibility Graphs", Mathematics Subject Classification: 05C62, 2008.
- [8] A. M. Dean and N. Veytsel. Unit bar-visibility graphs. Congressus Numerantium, 160:161–175, 2003.
- [9] G. Di Battista, P. Eades, R. Tamassia, and I. G. Tollis. Graph Drawing: Algorithms for the Visualization of Graphs. Prentice-Hall, Upper Saddle River, New Jersey, 1999.
- [10] F. J. Cobos, J. C. Dana, F. Hurtado, A. Marquez, and F. Mateos. On a Visibility Representation of Graphs. volume 1027 of Lecture Notes in Computer Science. Springer- Verlag, 1995.
- [11] kos Balazs dissertation of the doctoral degree Tessellation and rendering of trimmed NURBS models in scene graph systems. University of Bonn, (2008).
- [12] M. Dean, W. Evans, E. Gethner, J. D. Laison, and M. Safari. Bar k-visibility graphs. Journal of Graph Algorithms and Applications, 11(1):45–59, 2007.
- [13] G. Di Battista, P. Eades, R. Tamassia, and I. G. Tollis. Graph Drawing. Prentice Hall, Upper Saddle River, NJ, 1999.
- [14] P. Bose, A. Josefczyk, J. Miller, and J. O'Rourke. k42 is a box visibility graph. Technical Report #034, Smith College, 1994.
- [15] S. P. Fekete and H. Meijer. Rectangle and box visibility graphs in 3d. International Journal of Computational Geometry and Applications, 9(1):1–21, 1999.
- [16] P. Bose, A. Dean, J. Hutchinson, and T. Shermer. On rectangle visibility graphs. In Lecture Notes in Computer Science 1190: Graph Drawing, pages 25–44. Springer-Verlag, 1997.
- [17] G. Kant, G. Liotta, R. Tamassia and I. G. Tollis, "Area requirement of Visibility Representations of Trees". In Proc. 5th CCCG, pages 192-197, Waterloo, Canada, 1993,
- [18] A. M. Dean, J. A. Ellis-Monaghan, S. Hamilton, and G. Pangborn. Unit rectangle visibility graphs. Electronic Journal of Combinatorics, 15(#R79):1–24, 2008.
- [19] Alice M. Deana and Joan P. Hutchinsonb, "Representing 3-trees as Unit Rectangle-Visibility Graphs", Congressus Numerantium, 2010.

- [20] Alexander Kuznetso, Igor Pak, Alexander Postnikov, "Trees Associated with Motzkin Numbers". Journal of Combinatorial Theory, Series A 76, 145-147(1996), Article No. 0094.

#### AUTHORS

**First Author** – Mehnuma Tabassum Omar, B.Sc(CSE), M.Sc(CSE on going), Khulna University of Engineering & Technology, misty2409@gmail.com

**Second Author** – Kamrun Naher, B.Sc(CSE), Khulna University of Engineering & Technology

**Third Author** – Monika Gope B.Sc(CSE), M.Sc(CSE on going), Khulna University of Engineering & Technology, gopenath14@yahoo.com

**Fouth Author** – Ummay Asma, B.Sc(CSE), Khulna University of Engineering & Technology

# Application of Information Computer-based Learning in Calculus Package Learning

Mathilda Lasut\*

\* Department of Mathematics, Faculty of Mathematics and Science, Manado State University, Indonesia

**Abstract-** This study aims to determine the effectiveness of Information Computer Technology (ICT)-based learning packages focusing on calculus courses among college students, and to find a tested learning package model in the ICT-based learning of calculus. This study was developmental research which includes requirements analysis, designing learning packages, and evaluation of the learning package. Design research uses literature study, survey, application of learning packages, evaluation and content analysis. Overall, 35 college students of Department of Mathematics, Faculty of Mathematics and Science, Manado State University who take calculus courses were participated. Data were analyzed using descriptive analysis argumentative. After applied of this model, the results showed that there was increased in learning outcomes and level of understanding of the concept of differential and integral. It was influenced by the type of learning media that applied to the ICT-based learning package, namely the application program camtasia on power point programs. ICT-based learning was a contextual and based on the philosophy of constructivism learning so this study suggests that this model would become very well implemented in calculus. Therefore, more research on the effectiveness of ICT-based learning model is also needed for other majors. *(This finding has been presented in the 3<sup>rd</sup> International Seminar on Quality & Affordable Education, November 2014, in University of Malaya, Kuala Lumpur)*

**Index Terms-** Calculus, ICT, package learning, development, camtasia

## I. INTRODUCTION

Developments in science and technologies are rapidly, as with most new approaches-based technologies used in education demanding quality human resources (Oliver 2005). In the educational systems, personalization that is governments, teachers, parents and school communities' proses is growing importance (Campbell 2007). Improvement of personalization learning process particularly academic communities become leaders in the application of technologies is also a requirement for achieving development goals to provide a different kind of learning approaches (Laurillard 2002, Green & Brown 2002).

Nowadays, many integrated packaged learning have been developed and applied to the students. Most of the systems used to increase the students' motivation, which can be increased using the cognitive tools model that has the following functions: as an information seeking, information presentation, knowledge

organization, knowledge integration, and knowledge generation (Figure. 1)

Tool Category	Tool Function	Tool Type
Information seeking	Identify, locate, retrieve relevant information	Digital libraries, keyword searches, websites, wikipedia, online dictionaries
Information presentation	Present relevant information in variety of formats to enhance interpretation	Discussion boards, blogs, spreadsheets, Google docs/maps
Knowledge organization	Establish conceptual relationships, reconstruct and manipulate information	Concept maps, powerpoint, graphic organizers, smartboards
Knowledge integration	Connect existing with new knowledge, test relationship between them, process at deeper levels	Simulation tools, concept maps, games
Knowledge generation	Mirror knowledge generation process, generate and manipulate new knowledge, represent new knowledge flexibility and meaningful	iMovie or MovieMaker Web Page development

Figure. 1: The cognitive tool categories and their functions and types (Iiyoshi 2005)

Globally, revolution technology, especially computers and the international network have fundamentally changed the way of looking and thinking in a practical and efficient of academics environment to deliver online learning (Coaldrake 2000, Heinich 1989). In order to improve education, knowledge and the environment available to learners, we are now facing with a threshold gate-based technologies transition, where the speed of give and capture the information become very important (Goodyear 2001). Therefore, academics would need to be ready for preparing optimally to face the dynamic society or the era of dynamic communities that we expect to be realized in the coming years. Recently, adoption of the Information and Communication Technology (ICT)-based learning, such as online learning have widely used in some universities on professional development programs and reported these to be of substantial benefit (Weaver 2006).



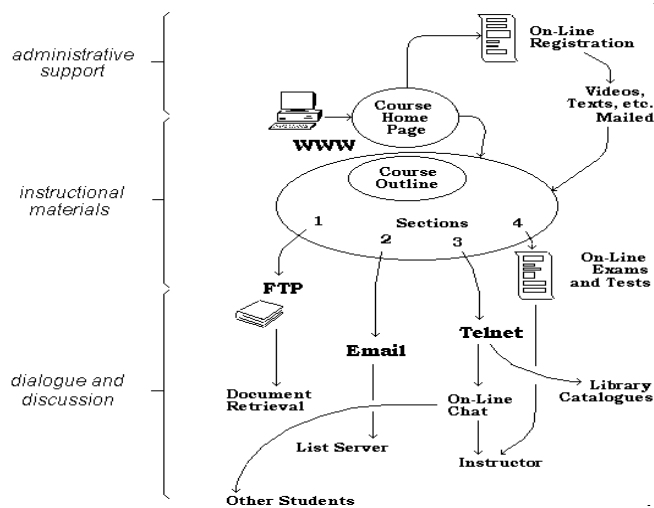


Figure 2: Schematic model of ICT-based learning

Most of developed countries have adopted and made ICT-based learning (Figure. 2) as an integral part of the education system, because education of a nation in the 21st century will be difficult to develop and progress, if the ICT is not integrate in the system (Becker 2007). Moreover, ICT-based learning in line with the current educational paradigm is shifting from a system of teachers' education and training oriented to the students' system oriented.

The growth of long distance education, the more the web site content in the international network which providing

## II. RESEARCH METHOD

### Study design

This was a development research study focusing on implementation of a learning design with the use of ICT. It included requirements and resources analysis, design of learning packages, and their evaluation. Stages of the research conducted were literature study, survey, application packet learning, evaluation and content analysis. The study sample was set among college students who are prospective teachers that studying in Department of Mathematics Education, Faculty of Mathematics and Science, Manado State University, which consists of three classes that follow the course of calculus. Overall, 35 college students who take calculus courses were participated.

### Materials

The instruments used in this study were the observation worksheets (questionnaires), ICT-based learning packages of calculus courses, LCD, international network, and laptops or personal computers. The observational worksheets were research-made, which were theoretical part to measure students' content knowledge of differential and integral subjects of calculus courses.

### Learning packages development

The procedure used in the development of this ICT-based learning tools of calculus consists of four steps: (1) expert

guidance or learning materials, the more conscious people life long learning, the establishment of international schools stating the importance of ICT in modern education. Based on this fact, the academics must be able to implement a qualified and modern learning system, and providing greater opportunities for students to engage and reflect on their own experiences through ICT-based learning.

In Indonesia, utilizing information and communication technology in schools is one of the efforts to improve the quality of education. In line, various education studies in the world showed that the utilization of instructional materials is packaged in the form of medium development based on ICT can improve the quality of education (Shovein 2005). On the other hand, our academic resources have basic problem such as English proficiency, which usually used in the technology

Calculus is one of the courses that are difficult to understand by the students. It needs methods and approaches for effective learning the formulas, particularly, in calculus courses. ICT-based learning is contextual and based on the philosophy of constructivism learning, therefore, this is may be the best system to apply in calculus courses. Therefore, this study aims to determine the effectiveness of ICT-based learning packages of calculus courses among college students of Department of Mathematics Education, Faculty of Mathematics and Science, Manado State University and to find out a tested learning package model of ICT-based learning of calculus courses.

review, (2) the evaluation of individuals knowledge, (3) evaluation of the group of learning, and (4) the trial court, which was operationalized through the following procedure: 1) Conduct a survey among student of Department of Mathematics Education those attended calculus class about information technology textbooks used by lectures and students was conducted; 2) Review the syllabus and contents, and standard of competency of calculus courses; 3) Draft a learning package of calculus syllabus, content standards and competencies; 4) Perform content analysis by distributing a draft learning package of calculus, questionnaire, and a spreadsheet to four lecturers consisting of two calculus and IT two lecturers to get feedback in improving ICT-base learning package; 5) Implement discussions with experts as a validation of the draft learning package. The results of experts' analysis showed that the learning package in accordance with the characteristics of the material being taught and does not contain misconceptions, and readily accepted and applied to the students; 6) Revise the draft of learning package on the basis of experts' recommendations; 7) Write the report.

Learning package was prepared in appropriating to differential and integral subjects of calculus courses. Power point and Camtasia programs were used in preparing of learning packages of these subjects. Prior to the implementation of ICT-based learning package, a pre-test was conducted to get the data of students' prior knowledge of differential and integral subjects of calculus courses.

### Learning package analysis evaluation form

In order to improve the learning package that have prepared and to measure the validity of the test, experts evaluated 1) the observational worksheets of content knowledge that prepared for participants; 2) learning packages; and 3) evaluation forms. On the evaluation forms, the experts were asked to provide their feedbacks, included comments or suggestions. The worksheets and evaluation forms were categorized in five group questions, namely: 1) Content standards (concept); 2) Competency standards (competency to be achieved); 3) Learning process standards (learning process in the use of learning packages); 4) Enrichment materials; 5) Potential needs and implementations analysis.

*Data analysis*

Data were analyzed using descriptive analysis argumentative. The results of the analysis were used as the basis for developing a draft of ICT-based learning package of calculus courses.

**III. FINDINGS**

*Application of ICT-based learning package*

All of the participants successfully completed the pre- and post-tests. Table 1 contained their mean scores for contents knowledge based on traditional learning process. Although the highest value was at score 3,25, but about 50% of students were at score less then 2 with the lowest score of 1,25. Of students, only 18% have finished read the materials of learning trough the traditional learning approaches. 67% of participants reported that they did not understand well about the concept of differential and integral subjects that they have learned previously through the lecture method. Overall, the results of preliminary tests showed that the students' understanding of differential and integral subject that has been studied was low. These data showed the need for action or alternative learning approach to increase the level of students' understanding of differential and integral subjects.

Table 1. Preliminary result of students' prior knowledge before application of learning package

No	Parameters	Score / Percentage
1	The highest value*	3,25
2	The lowest value*	1,25
3	Students have not been thoroughly studying	82 %
4	Students finished read the learning material	18%
5	Responses about the difficulty of test	23 %
6	Responses about the difficulty to understand the learning materials	67%

\*value score : 0 - 4

After completing courses in which the ICT-based learning package was applied to prospective teachers, the results of the written test showed any increased in learning outcomes and level of understanding of the concept of differential and integral. The lowest level value was extremely increased to 2,95 from 1,25, and all the participants (100%) reported that they finished read the learning materials through the ICT-based

learning approach. The passing rate of students has met the standards of mastery learning, which were planned in the syllabus of calculus courses (Table 2).

Table 2. The test results after applied the ICT-based learning package

No	Parameters	Score / Percentage
1	The highest value*	3,85*
2	The lowest value*	2,95*
3	Students have not been thoroughly studying	0 %
4	Students finished read the materials	100%
5	Responses about the difficulty of test	0 %
6	Responses about the difficulty to understand the learning materials	2%

\*value score : 0 - 4

It was suggested that the ICT-based learning package affected and provided to assist learners in improving their learning outcomes and level of understanding, particularly in differential and integral subjects of calculus courses. Nevertheless, this learning packages need to be assessed by the lecturers in the class to further enhance the quality of these packages.

*Evaluation of the contents*

Table 3 showed the result of experts' feedback. Content standards, competency standards, learning process standards, enrichment materials, and potential needs analysis were evaluated.

Table 3. Analysis of experts' evaluation

No	Description	Average (%)	Qualification
1	Content standards	100	Good
2	Competency standards	100	Good
3	Learning process standards	85	Enough
4	Enrichment materials	95	Good
5	Potential needs analysis	90	Enough

All of the experts agreed on the leading position of these valuable criterions, in the order of priority. Although some experts believe that the role of learning process standards should not be diminished, with only some of the students rating this criterion as very important during the study, the result of post-test has revealed that it can be viewed as necessary.

Based on the average percentage in each question group, it appears that for the first group, namely content standards and the second group specifically if the material meets the competency standards, all respondents gave the answer of

100%. While for third group whether the material meets the learning process standards, on average 85% confirmed that the material was in conformity with the learning process standards. For the fourth groups, when asked about the materials enrichment, on average 95% said there was, and 90% of respondents in fifth groups confirmed if the material based on the experiences and needs of students. Overall, experts' evaluation concluded that the draft of ICT-based learning package for differential and integral subjects of calculus courses can be considered quite good.

The results of this study found that the implementation of ICT-based learning was effective in enhancing college students' content knowledge particularly in differential and integral subjects. The findings were substantially in line with those of Gulsecen (2006) found that ICT-based learning skill throughout the problem based learning as an effective learning tool in motivating prospective teachers' involved in the learning process and solve their learning problem (Gulsecen 2006). A study conducted among pre-service teachers in Singapore reported that participants in this study were able to understand the importance of problem based learning and ICT-based learning integration (So 2009). Consistently, a study that aimed to produce a reusable learning model for assisting the academics in higher education in Australia indicated that ICT-based learning have potential to foster high quality learning. Moreover, this model has become commonplace as one of the practicum medium for academics' learning in Australia universities, as well as for reducing costs of universities (Agostinho 2002).

#### IV. CONCLUSION

The findings of this study highlighted the importance of effective method and design of technology and online learning, and its implementation. This study demonstrated the effectiveness and extremely importance of camtasia on MS Powerpoint program and its capability as a ICT-based learning approach in increasing the prospective teachers' prior knowledge, autonomy and leadership especially in calculus courses. ICT-based learning was a contextual and based on the philosophy of constructivism learning so this study suggests that this model would be very well implemented in learning process, particularly in mathematics. Considering the result of this study, some suggestions were made for implication of this finding. First, future researchers on the effectiveness of ICT-based learning scenarios with larger sample size is needed not only in calculus courses but would be necessary for different courses as well. Secondly, it is important to conduct studies comparing the use of ICT-based learning model and without any model or other methods. Thirdly, some suggestions are also made as to how academics may provide on the best opportunities offered by this learning medium. Furthermore, to how universities as learning institutions to ensure that all those involved are supported by high quality infrastructure, processes of designing and professional development.

#### ACKNOWLEDGMENT

I would like to thank all participants for their valuable contributions in this study. This project was partly funded by the

Ministry of National Education and Culture, Indonesia, Directorate General of Higher Education, as part of the research scheme namely *Penelitian Hibah Unggulan Perguruan Tinggi*.

#### REFERENCES

- [1] R. Oliver, The more years of educational technologies in education: How far have we travelled. *Australian Education Computing*. 2005, pp. 18-23.
- [2] R.J. Campbell, Personalised learning: Ambiguities in theory and practice, *British Journal of Educational Studies*, 2007, pp: 135—154.
- [3] D. Laurillard, Rethinking teaching for the knowledge society. *Educause Review*. 2002, pp: 16-22.
- [4] Green & Brown. *Multimedia Projects in The Classroom*, California, Corwin Press, Inc 2002.
- [5] T. Iiyoshi, *Cognitive tools and student centered-learning: Rethinking tools, functions, and applications*. Eduactional Media International. 2007, pp: 281-296.
- [6] P. Coaldrake, Rethinking academic and university work. *Higher Education Management*. 2000, pp: 7-30.
- [7] Heinich, *Instructional Media: And The New Tecnology of Instructional*, 3rd. ed., New York: Macmillan Publishing Company, 1989.
- [8] P. Goodyear, Competences for online teaching: A special report. *Educational Technology, Research and Development*. 2001, pp: 65-72.
- [9] D. Weaver, The challenges facing staff development in promoting quality online teaching. *International Journal on ELearning*. 2006, pp: 275-286.
- [10] K. Becker, Impact of personalised learning styles on online delivery and assessment. *Campus Wide Information System Journal*. 2007, pp: 105-119.
- [11] J. Shovein, Challenging Traditional Teaching and Learning Paradigms: Online Learning and Emancipatory Teaching. *Nursing Education Perspectives*. 2005, pp: 340-343.
- [12] S. Gülseçen, Teaching ICT to teacher candidates using PBL: A qualitative and quantitative evaluation. *Educational Technology & Society*. 2006, pp: 96-106.
- [13] H.J. So, Learning about problem based learning: Student teachers integrating technology, pedagogy and content knowledge. *Australasian Journal of Educational Technology*. 2009, pp: 101-116.
- [14] S. Agostinho, *A tool to evaluate the potential for an ICT-based learning design to foster "high-quality learning"*. In A. Williamson, A. Young, C. Gunn & S. Clear (Eds.), *Winds of change in the sea of learning*. Proceedings of the 19th Annual Conference of the Australasian Society for Computers in Learning in Tertiary Education, 8-11 December 2002, pp. 29-38.

#### AUTHORS

**First Author** – Mathilda Lasut, Associate Professor, Manado State University, Indonesia, [mathildalasut@gmail.com](mailto:mathildalasut@gmail.com)

**Correspondence Author** – Mathilda Lasut, [mathildalasut@gmail.com](mailto:mathildalasut@gmail.com), +62-82188334950

# Photon Induced Electron Transfer in Quantum Dot Solar Cell

Ubani Charles Ahamefula

\*Department of Physics, Universiti Kebangsaan Malaysia, Bangi, 43600 Selangor D.E., Malaysia.

**Abstract-** Low dimensional semiconductor crystals structures otherwise known as quantum dots are in possession of unique optoelectronic properties that allow the flow of electrons to be harvested instantaneously. The advent of quantum dot for various technological applications is motivated by their flexibility of their bandgap supporting their capability to tap power from the visible spectrum as well as the invisible infrared through absorbable wavelength ranges from about 700 nanometre to 10 micron. Besides the wide energy harvesting range, quantum dot utilizes small to area for high energy production. The emergence of quantum dot and its application in optoelectronic device such as solar is set to improve the efficiency limit of traditional devices. The configuration of quantum dot in solar cell is discussed as well as electron transfer processes. Their three unique advantages for solar-to-electric energy conversion such as provision of large surface and interfacial areas per unit volume for light absorption and charge separation. The confinement process of charge carriers in quantum dot provides the ability to tune the optical and electronic properties of materials in ways that are not possible with bulk materials. The study shows that the incorporation of quantum into solar cell could enhance the performance of devices and as well, low their cost.

**Index Terms-** Quantum dots, Electron transfer, optoelectronic properties, Charge carriers, Solar cell.

## I. INTRODUCTION

The cost of photovoltaic (PV) power is determined by the PV module conversion efficiency as well as the capital cost of the PV system per unit area. The ratio of the capital cost per unit area (RM/m<sup>2</sup>) to the peak power (Wp) produced per unit area yields the generated power cost in the unit of RM/peak watt (RM/Wp). The cost of finite energy sources (gas and petroleum) in 2007 ranges from 0.25 – 0.35 RM/kWh while PV generated power was in the range of 28 RM/Wp (RM 17.5 for the PV module plus RM 10.5 for the balance of system cost). Owing to the increase in energy demand, active components for PV cell must be rid of the barriers to high efficiency such as the avoidance of internal losses due to non-radiative centres and the generation of excessive heat which is predominant in conventional silicon based solar cells. Presently, the market share of silicon-based solar cells comprises single crystal, polycrystal, and amorphous silicon is about 99%. Silicon-based solar cell consumes huge amount of energy, requires high temperature purification of the raw material and many processing steps and as a result, is expensive. “Photon induced charge transfer of quantum dot in solar cell” is favoured by nano-sized domain energetic semiconductors particles capable of absorbing wide electromagnetic spectrum and can be structured to avoid premature recombination of electrons-hole pairs.

To meet the global energy demand as well as encouraging wider use of solar power on terawatt scale (TW), there is need to develop low-cost PV cell with high conversion efficiency. The efficiency of semiconducting material used in solar cell for absorbing sunlight varies with respect to their energy gap while, the solar spectrum contains photon of wavelength between 700nm to 10 micron or in terms of energy between 0.5eV to 3.5eV. Absorption of solar photons larger than the bandgap create electron – hole pairs with the total energy equivalent to the difference between the photogenerated electron energy and the conduction band energy [1–4].

However, in a single-junction solar cell made of semiconductor material such as silicon, spectral losses can be as large as 50%. This is as a result of the mismatch between the incident solar spectrum and the spectral absorption properties of the material [5]. Large part of the solar spectrum is not absorbed as a result of the band gap (E<sub>g</sub>) of the material. Photons with energy (E<sub>ph</sub>) larger than the band gap are absorbed while the excess energy E<sub>ph</sub>–E<sub>g</sub> is effectively transferred to the electrons as thermal energy. Photons with E<sub>ph</sub> < E<sub>g</sub> are not absorbed. Alternatively, report [6] on CuInSe<sub>2</sub> (CIS) based solar cell is promising though limited by the complexity and complicated nature of the technology. In search for breakthrough on cost and efficiency, nanocrystalline dye sensitized solar cells in contrast to Si and CIS cells offer promising functional element for light absorption as well as charge separation. Currently, the chemisorption of dye on the surface of the semiconductor was developed to enhance the function of the dye [7, 8]. The concept uses dispersed particles to provide enhanced surface interface [9]. Photoelectrodes having high surface roughness were employed with TiO<sub>2</sub> as the choice semiconductor [10, 11]. The materials are inexpensive, non-toxic and abundant. A conversion efficiency of 7.1 % was obtained in 1991 [12] while the efficiency to date is over 18 %. In another development, quantum dot solar cells exploit quantum confinement either to tune the optical absorption spectrum of the solar cell or to generate multiple excitons (MEG). Though this has not to date been demonstrated in an actual solar cell several proposed designs have been reported [13, 14]. In these designs the dye molecules are replaced with a layer of quantum dots adsorbed onto nanowires. Such solar cell operates in a similar manner to the dye

sensitized solar cell but the light would be absorbed by the quantum dots instead of the dye molecules. The concept of quantum dot sensitized solar cell [15] based on CdSe quantum dots attached to ZnO nanowires was used to demonstrate the absorption of light energy to generate electrons that were then transferred to the nanowire to create electrical current. Report shows that better utilization of the solar spectrum takes place in quantum dot sensitized solar cell [16]. Besides its wide energy harvesting range, quantum dot may be painted onto walls or windows, sprayed on clothing, or printed onto rolls of paper. Owing to the design flexibility of QDSSCs, handheld devices ranging from PDAs and iPods to cell phones could be powered eliminating need for electrical cords through the use of QDSSC.

## II. QUANTUM DOTS SENSITIZATION SOLAR CELL (QDSSC)

Quantum dot sensitized solar cells (QDSCs) offers an ideal approach to third generation solar cells [17-20]. The intrinsic attractive properties of quantum dots (QDs) (tunable band gap [21] high extinction coefficients, [21, 22] and large intrinsic dipole moment [23, 24]) is of advantage over metallorganic dyes as alternative light absorbing medium. Couple with the demonstration of MEG by impact ionization, QDs [25, 26] could extend the thermodynamic efficiency limit of these devices to 44% [18] ignoring 31% of the Shockley Queisser detailed balance limit. Although the conceptual efficiencies of QDSCs have not been attained [27] QD-sensitized nanostructured solar cells are rapidly been researched on as a promising alternative to conventional solar cells [28-31]. The principle of the sensitized solar cell is explained in Fig. 1.

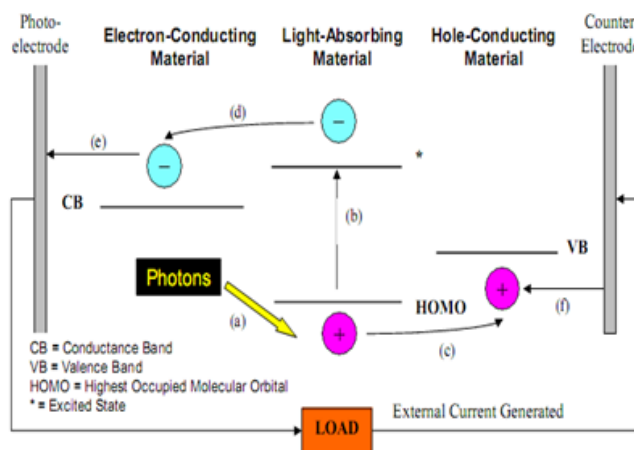


Fig. 1 Generalised Electron and Hole Orbital and Cell Movement in QDSSCs: (a) Photoexcitation of the Light-Absorbing Material; (b) Electron/Hole Pair Photogeneration; (c) Movement of the Generated Hole from the HOMO of the Light-Absorbing Material to the VB of the Hole-Conducting Material via the Transfer of an Electron from the Latter to the Former; (d) Electron Flow from the Excited State of the Light-Absorbing Material to the CB of the Electron Conducting Material; (e) Electron Flow Through the Photoelectrode and the External Circuit, Re-entering Through the Counter Electrode; (f) Regeneration of the Hole-Conducting Material

In general, sensitized solar cell is made up of three principle components: a light-absorbing material, an electron-conducting material and a hole-conducting material. A Quantum Dot Sensitized Solar Cell is shown in Fig. 2. In a QDSC, it is the QDs that absorb the light, creating an electron/hole pair. The efficiency of QDSSCs depends on the spectral absorbance of the QDs semiconductor material and the electron/hole injection efficiency, the electron transport and recombination rates, which are dependent on the electron-conducting material; and the hole transport and stability is related to the hole conductor used. The processes taken place in a QDSSC such as photoexcitation, electron injection as well as recombination of electrons and holes is shown in Fig. 2. QDSSC are sandwiched between two electrical contacts or electrodes.



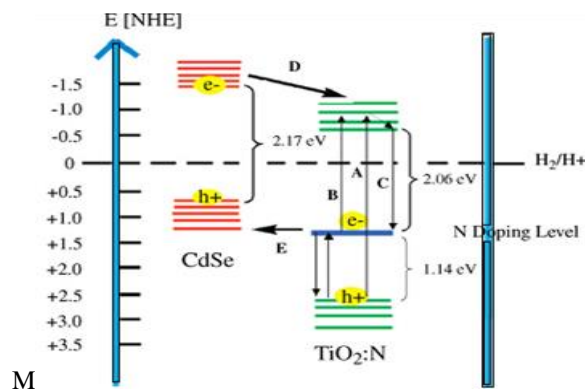


Fig. 2 Diagrammatic representation of electronic band structure of 3.5 nm CdSe with bandgap of 2.17 eV and nanocrystalline TiO<sub>2</sub>:N having bandgap of 3.2 eV, in association with TiO<sub>2</sub> and a N dopant state of about 1.14 eV above the valence band. Electron and hole generation, relaxation, and recombination pathways are shown in the figure with (A) photoexcitation of an electron from the valence band (VB) to the conduction band (CB) of TiO<sub>2</sub>, (B) transition or photoexcitation of an electron from the N energy level to the CB of TiO<sub>2</sub>, (C) recombination of an electron in the CB of TiO<sub>2</sub> with a hole in the N energy level, (D) electron transfer or injection from the CB of a CdSe QD to the CB of TiO<sub>2</sub>, and (E) hole transfer from the VB of a CdSe QD to the N energy level. Note that not all of these processes can happen simultaneously, and many of these are competing processes. [76].

On illumination and creation of electron/hole pairs, electrons injected into an electron-conducting material flow through to the anode and return through the cathode creating an external current which can be used by a load. The electron reduces the oxidised hole conductor and restores it to its original state as shown in Figure 3.1.

The sensitization of a wide gap nanostructured semiconductor electrode such as TiO<sub>2</sub> and ZnO with QDs can be achieved through either; (1) direct growth of the semiconductor QDs onto the electrode surface by chemical reaction of ionic species using chemical bath deposition (CBD) [30 - 33] or successive ionic layer adsorption and reaction (SILAR) [34, 35] and (2) through presynthesized colloidal QDs attached to the electrode material by a bifunctional linker molecule [36-40]. The attachment of colloidal QDs through molecular wires enhances the morphological properties of the semiconductor nanocrystals. Attaching the QDs onto the TiO<sub>2</sub> surface without molecular linkers is termed direct adsorption (DA) [41]. Higher surface coverage of colloidal QDs on the TiO<sub>2</sub> substrate improves the efficiencies of QDSSCs as well as the network configuration.

### III. CONFIGURATION OF QDS IN SOLAR CELL

#### A. The Sensitizer

The sensitizer on the surface of the nanocrystalline semiconductor absorbs incoming photon flux. To achieve high conversion efficiencies, the photochemical, electrochemical, and chemical properties of the sensitizer play important role. Owing to the quantum size effect the edge of the absorption spectra of QD material can be tuned to different sizes. This can be done by varying the synthesizing temperature. Such an effect produces narrow size distribution [42-45] as absorption occurs throughout the visible region. To ensure a good injection rate of the photoexcited electron from the sensitizer into the TiO<sub>2</sub> a long excited state of the sensitizer is necessary since injection occurs on the femto-to picosecond time scale. The sensitizer performance determines the output current of the QDSSC [46]. An illustration showing the generation and flow of electron/hole pairs, through the anode to the cathode is as shown in Fig. 3. The oxidized hole restores the system to its original state.

For efficient electron injection into the TiO<sub>2</sub>, the energy level of the sensitizer excited state must be higher than the energy of the lower edge of the conduction band of the semiconductor as the oxidation potential of the sensitizer excited state increases negatively than the oxidation potential of the TiO<sub>2</sub> semiconductor. On the other hand, the energy level of the oxidized sensitizer has to be lower than the energy level of the reduced hole-conductor to ensure an efficient regeneration of the sensitizer. For the QD size distribution, a size limit exists for the nanoparticles to inject electrons into the TiO<sub>2</sub> [47].

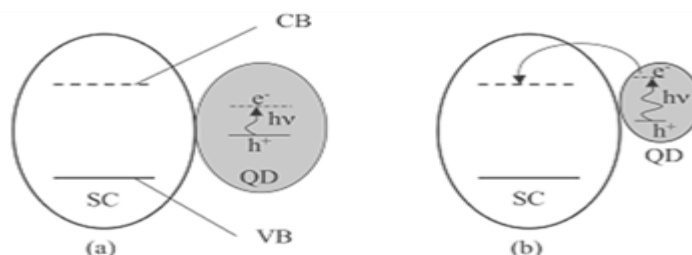


Fig. 3 Electronic levels in semiconductor (SC) and QD particles showing the valence band (VB), conduction band (CB) in (a) Large CdSe particle, (b) Small CdSe particle

Illustration in (Fig 3.(a) is dominated by large QD particles which is adsorbed onto the semiconductor; its small band gap is as a result of weak quantum confinement. However, energy of the photogenerated electron in this particle is weaker resulting in poor injection of electron into the semiconductor to affect the process. However, smaller QD as in Fig. 3. (b) depicted that the energy of the photogenerated electron is greater than that of the lowest unoccupied molecular orbital (LUMO) of the semiconductor resulting in rapid electron tunneling to the TiO<sub>2</sub> particle. To achieve good adsorption of the sensitizer on the semiconductor, chemical bonds have to exist between both which however, depend on the synthetic route. For QD grown directly on the surface of the semiconductor the anchoring is due to bonds appearing between the deposited metal ions and the oxygen atom at the surface. QD may also be formed in the bulk of the deposition solution before migrating to the surface of the semiconductor. The adsorption of the particle may not be due to metal/oxygen bonds in this case, as no metal valences are available. For metal selenide QD, there is tendency for a hydrogen bond to form between the selenide atom and the oxygen at the surface.

### *B. Electron-Conducting Material*

Electrons generated in QDSSCs flow through the conduction band of TiO<sub>2</sub> to an electrode. The conduction band energy electron must be efficient for electronic coupling with the sensitizer energy levels and charge separation to minimize the recombining of the electron with the sensitizer. An electron-conductor with low level of recombination and good electrical connectivity to the electrode/substrate is preferred. [48] A situation where the injection is greater than the rate of recombination is termed kinetic redundancy. [49] The kinetic redundancy can be modified by changing the sensitizer-electron-conductor linker groups. [49] Usually anatase and rutile are used as the linkers. Anatase is preferred to rutile because it is transparent, colourless and stable at low-temperature. [50] Besides, it has a better light scattering property when compared to rutile, and its efficiency is higher by a factor of five. [51]

The success of QDSSCs has been partly attributed to the fast electron injection from the QDs to the TiO<sub>2</sub> and a slower reversal process [52]. High speed electron injection is consistent with near 100 % quantum efficiency [51]. Alternative wide band gap materials such as ZnO [53, 48, 54, 55, 56], Nb<sub>2</sub>O<sub>5</sub> [53, 57], SnO<sub>2</sub> [53] and In<sub>2</sub>O<sub>3</sub> [53] are insensitive to the visible spectrum and absorb high energy UV wavelengths. Such qualities are desirable as they imply strong chemical bonds, stable material [58] and are transparent to visible light as a result and are therefore more efficient at creating stable electron/hole pairs.

### *C. Photoelectrode*

The type of electrodes use in QDSSCs affects the overall cell performance and marketability of a solar cell. Pt-free counter-electrodes use in QDSSCs with Au and Cu<sub>2</sub>S electrodes are expensive [59, 60]. However, carbon electrode has emerge as a better alternative to Pt electrode owing to their low cost, high electric conductivity, heat resistance and corrosion-inert. Activated carbon-based electrode assembles onto CdS QDSSCs yielded conversion efficiency of 1.47%. [61]. Photoelectrode fabricated by sequential assembly of CdS and CdSe QDs can effectively be adsorbed on ZnO nanowire array. The electrodes with nanospheroidal morphology have shown better performance compared to P25 nanoparticle electrodes owing to their connectivity among nanospheroidal TiO<sub>2</sub> particles and deeper penetration of the electrolyte in QDSSC [62].

### *D. The Photoelectrode-Anode*

The anode is the electron-conducting electrode termed photoelectrode as it is the illuminated electrode. Electron-conducting materials are usually placed onto the anode to maximize contact by doctor blading, [63, 53, 64-66] screen printing, [63, 67, 50, 64, 68], spin coating, [69] or sol-gel deposition of dissolved electron-conducting material with a binder.[63, 70] The contact and electron-conducting material could be fired in air to about 450°C to 500°C in a case where TiO<sub>2</sub> is used to aid the removal of the binder and solvent [71] as well as sintering the electron-conducting particles to the substrate. [50, 72, 73].

### *E. The Counter Electrode (Cathode)*

Interaction between the hole conductor and the anode results in recombination [74]. The interaction at the cathode must be fast to be kinetically favourable. Base on this reason, the cathode for instance, (usually ITO glass) is often coated with carbon [75], platinum [53, 73, 48, 54] or gold. [67, 65, 69]. Poly (3,4-ethylenedioxythiophene) (PEDOT) coated Fx•SnO<sub>2</sub> glass could be used as counter electrode in TiO<sub>2</sub> QDSSCs. [74]. In addition, coating the back electrode of QDSSCs with platinum could improve cell performance. [51] The cathode can as well be adjusted to accommodate equilibrium potential close to the hole conductor's, as the anode (the photoelectrode) is predominantly far from the equilibrium potential. Such coating would not be necessary for cells without iodide/triiodide based hole conductors. Electron transport in nanoparticle QDSSCs such as in TiO<sub>2</sub> occur either between the counter electrode and the working electrode by hopping [75] or through extended diffusion states [48]. Owing to the high electrons mobility in

nanoparticle, the disorder of the nanoparticle slows down the electron transport. Electron hopping in the nanoparticle network is efficient. Electron transport and recombination are interconnected in such a manner that any increase in the transport rate increases the recombination rate as well; keeping the QDSSC performance stable.[76] The ZnO nanowires with electron diffusivity of 0.05 to 0.5 cm<sup>2</sup>s<sup>-1</sup> could be an alternative to TiO<sub>2</sub> nanoparticle. ZnO nanoparticle provide direct path from photogeneration to conducting substrate and improve electron transport irrespective of its current densities which is the same with TiO<sub>2</sub> nanoparticle [77]. Every electron injected is connected to the substrate [78] as the coiled wires carry the injected electron to the anode. [48]

#### F. Electrolyte

Electrolytes in QDSSC contain the electrically conductive charges. The electrochemical potential of the interface between a semiconductor electrode and an electrolyte solution must be the same for the two phases to be in equilibrium. The excess of charge on the semiconductor due to low density of charge carriers could extend for 10-100 nm into the electrode and forms the space charge region. The space charge region is associated with positive charge. A p-type semiconductor usually has a Fermi level that is lower than the redox potential of the electrolyte and as a result, electron flows from the solution to the electrode to generate negatively charged space charge which causes downward bending of the bands. This phenomenon is as illustrated in Fig. 4

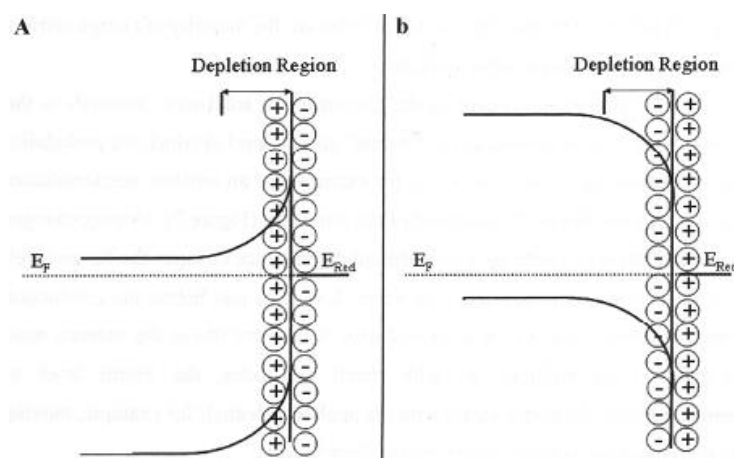


Fig. 4 Band bending for an n-type semiconductor (a) and a p-type semiconductor (b) in equilibrium with an electrolyte.

Exposing semiconductor electrode to radiations of sufficient energy, could promote electrons to the conduction band. This process results in recombination with the production of heat. If it occurs in the interior of the semiconductor the electrical field in the space charge region will promote spatial charge separation.

#### G. Liquid Electrolytes

Liquid electrolytes based on iodide/triiodide redox couple [64] prevents recombination with the electron by donating electron to the hole in the QDs [78] and oxidises to triiodide. Iodide is regenerated by the reduction of triiodide ion at the counter-electrode. The iodide/triiodide couple is ideal for QDSSCs application owing to the irreversible nature of the iodide to triiodide transition. However; the reverse process is kinetically unfavorable [79]. Replacing electrolyte-based components in QDSSC could enhance the cell performance. Gels [80-82] can replace liquid electrolyte in QDSSC such as Iodide-based (I-3I-) electrolyte and Pt electrode with CdS as sensitizer [83]. Hara et al. [68] found that increasing the concentration of the I- source from 0.007 to 3mol/dm<sup>3</sup> affects the short circuit current (I<sub>sc</sub>) and open circuit voltage (V<sub>oc</sub>). Increasing the concentrations of I-, I<sub>sc</sub> and conductivity of the electrolyte (I- and its cation) increase [68]. However, increasing the concentration of I- beyond the maximum point decreases I<sub>sc</sub> because of an increase in viscosity of the solution, which decreases ion mobility [68].

Charge separation is the building block of electron generation and takes place at the interface of the solar cell. The optimization of nanocrystalline QDSSC interface is investigated to minimize the losses resulting from direct recombination of the electron-hole pair after excitation (fig. 3.4 (K<sub>des</sub>)). Charge separation is efficient in QDs due to ultra-fast electron injection from the sensitizer to the semiconductor (fig. 3.4 (K<sub>inj</sub>)). However, interfacial charge recombination leads to high losses in the QDSSC as a result of the mesoporous network and the small distance between the electron and the holes [84].

The recombination of the injected electron with the oxidized sensitizer (fig. 3.4 (K<sub>reg</sub>)) is shown to be in the millisecond time range, which implies that the short-circuit potential will not suffer from recombination [84, 85]. To prevent the recombination of electrons collected from the conducting SnO<sub>2</sub> layer, the oxidized hole-conductor, a compact TiO<sub>2</sub> layer is usually deposited between the

conducting glass and the nanocrystalline TiO<sub>2</sub> [86]. The recombination process between the injected electron in the TiO<sub>2</sub> and the oxidized hole-conductor (Fig. 5 (K<sub>rec1</sub>)) is the major electron injection leading to the enhancement of the dark current.

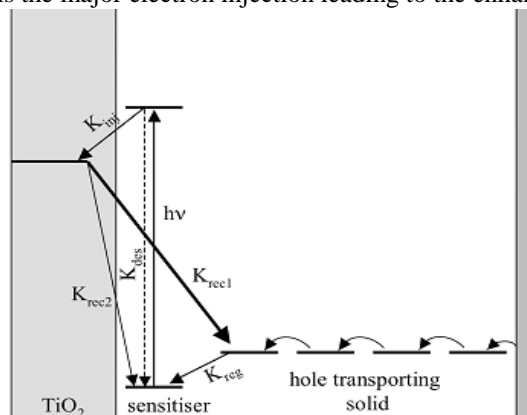


Fig. 5 Possible recombination pathway in QDSSC

Recombination occurs as a result of electron trapping in the surface states. The nanocrystalline (TiO<sub>2</sub>/ZnO) used in the QDSSC has large surface area. The deposition of a thin semiconductor layer covering the TiO<sub>2</sub> to preventing contact between the oxidized hole-conductor and the TiO<sub>2</sub> could increase the efficiency. Similar measure has been used to increase the photovoltaic device performances using ZnO [87], Al<sub>2</sub>O<sub>3</sub> [88], Y<sub>2</sub>O<sub>3</sub> [89] and SrTiO<sub>3</sub> [90]. However, long chain alkyls could be used to passivate the surface of semiconductors such as SiO<sub>2</sub> [91, 92]. The phosphonic or carboxylic groups help efficient adsorption at the surface. However, the long alkyl chain (Fig. 6) increases the distance between the surface and the electrolyte [93, 94] and enhances the short-circuit current while the open-circuit voltage could be increased with hexadecylmalonic acid (HDMA).



Fig. 6 Molecules of hexadecylmalonic acid (HDMA) used for the surface modification in QDSSC

#### IV. INTERACTION OF LIGHT WITH SEMICONDUCTORS

When a monochromatic incident light (I) hits a semiconductor material, a certain amount of the light energy is refracted (R) and certain proportion is transmitted (T). The transmitted light energy is absorbed by the semiconductor material to excite the electrons. The light energy enables the electrons to jump from one energy state to the other. When the photon energy is greater than the bandgap energy of the semiconductor, the absorption in the material occurs to excite the electrons from the highly occupied valance band towards the empty conduction band [95-96]. Excitations of electron and electron irradiation may lead to the generation of charge carriers.

##### A. Recombination Process:

As semiconductor is illuminated with light of appropriate wavelength, electron-hole pairs are formed. This increases the concentration of the charge carriers in the illuminated state compared to the dark state. As light is discontinued, the charge carries decay back to the equilibrium values. The process of decaying is refer to as recombination [97, 98]. The recombination process occurs in one of a few possible ways; a) an electron releases its energy through irradiative recombination which involves the emission of energetic photon; b) the electron losses its energy through Auger recombination by transferring energy to neighboring electrons [99] phonon is generated by losing the energy of the electron [98, 100]. It becomes clear that defects in semiconductor nanocrystals give rise to the differences in the energy level which is borne out of difference in bandgap energy. At the emergence of this phenomena, recombination processes slows down. As illustrated in Fig. 7, electron move from the conduction band to the defect energy level and then moves to the valence band annihilating the hole at the valence band. This process is known as trap.

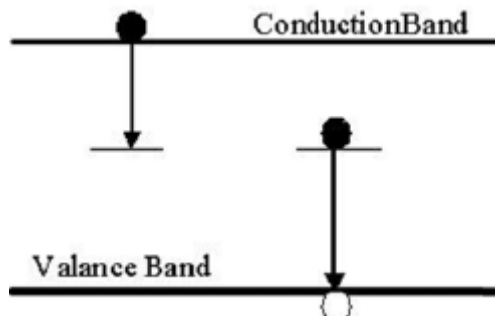


Fig. 7 Two-step recombination process at trapping level within the bandgap

The devices losses energy as result of recombination process. However, as recombination when the photon energy is discontinued from striking the semiconductor, the flow of current stop producing zero current output. When external trap is incorporated into the system, recombination slows down and allows the charges to flow. With the two-step recombination, the devices has higher chances of the charge carriers moving around the system. In application, this behaviour reduces the efficiency of a solar cell and can only be improved by introducing QDs with other semiconductor material [101] such as CdSe and PbSe QDs [102].

**B. Transport Process**

The charge in semiconductor materials are initiated by the movement of electrons throughout the delocalized band states [98]. In order to clearly explain charge transport process, transport of charge by the movement of electrons in the conduction band and movement of holes in the valance band is used in this paper. During the transport process of charges throughout the semiconductor material, phonons are created and this result to the increase in the temperature of the material and thus, introduces thermal conduction [103]. At thermal equilibrium, the carriers follow Boltzmann distribution depicting a function of temperature of the system [104]. Hence, hot carriers causes the decrease in the efficiency of the photovoltaic cells. The hot carriers exist in the system for a few hundred picoseconds before recombination. The hot carriers produce electric current. However, if the energy can all be captured from the hot carrier and transfer to electric energy, the efficiency of the solar cell would increase to about 66% [105] as illustrated in Fig. 8.

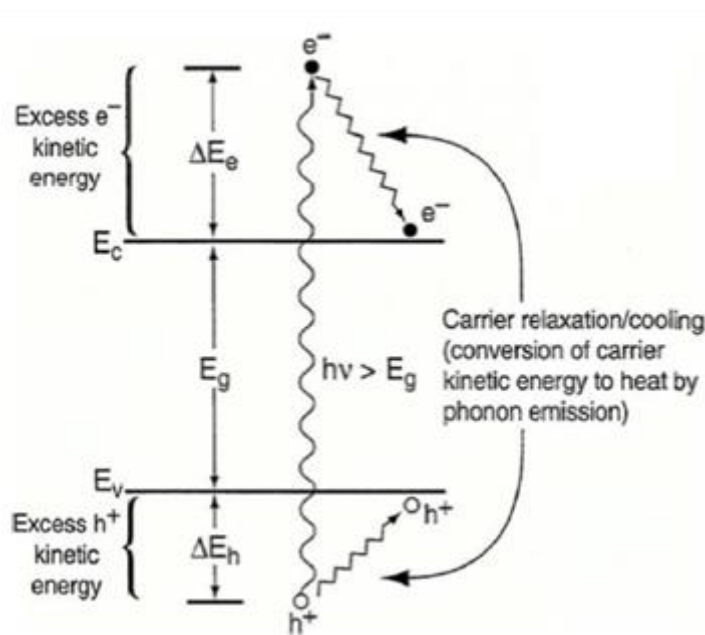


Fig. 8 Hot carrier relaxation/cooling dynamics in semiconductor [106]



## V. CONCLUSION

High cost and low efficiency of conventional single junction solar cells resulting from the inability of their to absorb and convert all the photon energy absorbed by free electrons and holes in the photon has retarded competitive use of photovoltaic cell. The flexibility and lower production cost afforded by quantum dot is promising to a wider range of applications especially for solar cells enhancement. The usefulness of quantum dot continues to strive as their application becomes more viable. Nanostructures present three unique advantages for solar-to-electric energy conversion which includes first, the provision of large surface and interfacial areas per unit volume for light absorption and charge separation. Second, confinement of charge carriers in nanometer size particles provides the ability to tune the optical and electronic properties of materials in ways that are not possible with bulk materials. Lastly, nanostructured materials could help reduce solar cell manufacturing costs by providing the means to mass produce thin films inexpensively through roll-to-roll coating or printing approach. Besides, the synthesis techniques could enable the design of sophisticated nanostructures. Besides, the design flexibility of QDSSCs could be utilized in powering handheld devices extending from PDAs and iPods to cell phones.

QDs provides a low surface coverage of about 14%. This paper discusses the structure of QDs devices and their optoelectrical properties capable of being manipulated by changing their particle sizes. The colloidal dispersion with particle size range of QDs improved the efficiency of device by absorbing wider electromagnetic spectrum. This process provided interconnections between the particles with electrical contact between them. The final film is mechanically stable, transparent and has a thickness of a few microns. Fabrication at the nano-scale provides a remarkable increase in the precision and level of control that can be obtained in solar cell development. The configuration of quantum dot in solar cell supports electron transfer processes besides their unique advantages that enhances solar-to-electric energy conversion such as large surface and interfacial areas per unit volume for light absorption and charge separation. In addition, the confinement process of charge carriers enables the tuning of the optical and electronic properties in such a way that support their use in different applications. It becomes clear that the incorporation of quantum in solar cell provides enhancement platform for devices performance.

## REFERENCES

- [1] A.J. Nozik, *Annu. Rev. Phys. Chem.*, 52 (2001) 193.W.-K. Chen, *Linear Networks and Systems* (Book style).Belmont, CA: Wadsworth, 1993, pp. 123–135.
- [2] R.T. Ross and A.J. Nozik, *J. Appl. Phys.*, 53 (1982) 3813.
- [3] D.S. Boudreaux and F. Williams, A.J. Nozik, *J. Appl. Phys.*, 51 (1980) 2158.
- [4] T. Markvart, *Solar Electricity*: John Wiley & Sons, 1994.
- [5] F.E. Williams and A.J. Nozik, *Nature*, 311 (1984) 21.
- [6] M.A. Green. *Solar Cells: Operating Principles, Technology and Systems Application* (Prentice-Hall, Englewood Cliffs, NJ, USA, 1982).
- [7] S. Wagner, J. L. Shay, P. Migliora, H. M. Kasper, *Applied Physics Letters* 1974, 25, 434.
- [8] M. P. Dare-Edwards, J. B., Goodenough, A. Hamnet, K. R., Seddon, R. D. Wright, *Faraday Discuss. Chem. Soc.* 1980, 70, 285.
- [9] H., Tsubomura, M. Matsumura, Y. Noyamaura, T. Amamiya, *Nature* 1976, 261, 402.
- [10] D. Duonghong, N. Serpone, M. Gratzel, *Helvetica Chimica Acta* 1984, 67, 1012.
- [11] J. Desilvestro, M., Gratzel, Kavan, L.; Moser, J.; Augustynski, J. *Journal of the American Chemical Society* 1985, 107, 2988.
- [12] N., Vlachopoulos, P., Liska, Augustynski, J.; Gratzel, M. *Journal of the*
- [13] A. Baxter., *Synthesis and Characterization of ZnO Nanowires and their Integration into Dye-Sensitized Solar Cells*, supra note 23 (figures reproduced from reference).
- [14] Nozik, A. J. "Multiple exciton generation in semiconductor quantum dots," *Chemical Physics Letters*, vol. 457, pp. 3-11, May 20 2008.
- [15] S., Kurtis Leschkies et al., *Photosensitization of ZnO Nanowires with CdSe Quantum Dots for Photovoltaic Device*, 7 *NANO LETTERS* 1793 (2007). S. Kurtis, Leschkies et al., *Photosensitization of ZnO Nanowires with CdSe Quantum Dots for Photovoltaic Device*, 7 *NANO LETTERS* 1793 (2007).
- [16] M.A. Green. *Third Generation Photovoltaics, Advanced Solar Energy Conversion* (Springer Verlag, Berlin, Germany, 2003).
- [17] A. J. Nozik, *Quantum Dot Solar Cells. Phys. E* 2002, 14, 115–200.
- [18] V. I. Klimov, *Mechanisms for Photogeneration and Recombination of Multiexcitons in Semiconductor Nanocrystals: Implications for Lasing and Solar Energy Conversion. J. Phys. Chem. B* 2006, 110, 16827–16845.
- [19] P. V. Kamat, *Quantum Dot Solar Cells. Semiconductor Nanocrystals as Light Harvesters. J. Phys. Chem. C* 2008, 112, 18737-18753.
- [20] P. Yu., K., Zhu, A. G. Norman, S. Ferrere, A. J., Frank, A. J. Nozik, *Nanocrystalline TiO<sub>2</sub> Solar Cells Sensitized with InAs Quantum Dots. J. Phys. Chem. B* 2006, 110, 25451–25454.
- [21] W., Yu., L. H. Qu., W. Z. Guo., X. G. Peng. *Experimental Determination of the Extinction Coefficient of CdTe, CdSe, and CdS Nanocrystals. Chem. Mater.* 2003, 15, 2854–2860.
- [22] P. Wang, S. M., Zakeeruddin, J. E. Moser, R. Humphry-Baker, P. Comte, V. Aranyos, A., Hagfeldt., M. K., Nazeeruddin, M. Gratzel, *Stable New Sensitizer with Improved Light Harvesting for Nanocrystalline Dye-Sensitized Solar Cells. Adv. Mater.* 2004, 16, 1806–1811.
- [23] R., Vogel, K. Pohl., H. Weller, *Sensitization of Highly Porous, Polycrystalline TiO<sub>2</sub> Electrodes by Quantum Sized CdS. Chem. Phys. Lett.* 1990, 174, 241–246.
- [24] R., Vogel, P., Hoyer, H. Weller, *Quantum-Sized PdS, CdS, Ag<sub>2</sub>S, Sb<sub>2</sub>S<sub>3</sub> and Bi<sub>2</sub>S<sub>3</sub> Particles as Sensitizers for Various Nanoporous Wide-Bandgap Semiconductors. J. Phys. Chem.* 1994, 98, 3183–3188.

- [25] R. D., Schaller, Sykora, M.; Pietryga, J. M.; Klimov, V. I. Seven Excitons at Cost of One: Redefining the Limits for Conversion Efficiency of Photons into Charge Carriers. *Nano Lett.* 2006, 6, 424–429.
- [26] M. T., Trinh, A. J., Houtepen, J. M.; Schins, T., Hanrath, J., Piris, W., Knulst, A. P. L. M., Goossens, L. D. A., Siebbeles. In Spite of Recent Doubts Carrier Multiplication Does Occur in PbSe Nanocrystals. *Nano Lett.* 2008, 8, 1713–1718.
- [27] B., O'ReganGraetzel, M. A Low-Cost High-Efficiency Solar Cell Based on Dye-Sensitized Colloidal TiO<sub>2</sub> Films. *Nature* 1991, 353, 737–740.
- [28] O., NiitsooSarkar, S. K.; Pejoux, C.; Ruzhale, S.; Cahen, D.; Hodes, G. Chemical Bath Deposited CdS/CdSe-Sensitized Porous TiO<sub>2</sub> Solar Cells. *J. Photochem. Photobiol. A* 2006, 181, 306–311.
- [29] L. J., Diguna, Q., Shen, J., Kobayashi, T. Toyoda, High Efficiency of CdSe Quantum-Dot-Sensitized TiO<sub>2</sub> Inverse Opal Solar Cells. *Appl. Phys. Lett.* 2007, 91, 023116.
- [30] H. J., Lee, J. H., Yum, H. C., Leventis, S. M., Zakeeruddin, S. A., Haque, P., Chen, S. I., Seok, Graetzel, M.; Nazeeruddin, M. K. CdSe Quantum Dot-Sensitized Solar Cells Exceeding Efficiency 1% at Full-Sun Intensity. *J. Phys. Chem. C* 2008, 112, 11600–11608.
- [31] Y., Diamant, S. G., Chen, O., Melamed, A., Zaban, Core-Shell Nanoporous Electrode for Dye Sensitized Solar Cells: the Effect of the SrTiO<sub>3</sub> Shell on the Electronic Properties of the TiO<sub>2</sub> Core. *J. Phys. Chem. B* 2003, 107, 1977–1981.
- [32] S., Giménez, Mora-Seró, I. Macor, L.; Guijarro, N.; T. Lana-Villarreal, R. GómezL. J. Diguna, Q., Shen, T., Toyoda, J. Bisquert, Improving the Performance of Colloidal Quantum-Dot-Sensitized Solar Cells. *Nanotechnology* 2009, 20, 295204.
- [33] Y. F. Nicolau, Solution Deposition of Thin Solid Compound Films by a Successive Ionic-Layer Adsorption and Reaction Process. *Appl. Surf. Sci.* 1985, 22 3, 1061–1074.
- [34] Y. F., Nicolau, M., Dupuy, M., Brunel, ZnS, CdS, and Zn1-XCdXS Thin-Film Deposited by the Successive Ionic Layer Adsorption and Reaction Process. *J. Electrochem. Soc.* 1990, 137, 2915–2924.
- [35] L., Robel, V., Subramanian, M., Kuno, P. V. Kamat, Quantum Dot Solar Cells. Harvesting Light Energy with CdSe Nanocrystals Molecularly Linked to Mesoscopic TiO<sub>2</sub> Films. *J. Am. Chem. Soc.* 2006, 128, 2385–2393.
- [36] T. Lopez-Luque, A., Wolcott, L. P., Xu, S., Chen, Z., Wen, J., Li, De la, E., Rosa, J. Z., Zhang, Nitrogen-Doped and CdSe Quantum-Dot-Sensitized Nanocrystalline TiO<sub>2</sub> Films for Solar Energy Conversion Applications. *J. Phys. Chem. C* 2008, 112, 1282–1292.
- [37] S. K., Leschkes, R., Divakar, J., Basu, E., Enache-Pommer, J. E., Boercker, C. B Carter., U. R., Kortshagen, , D. J., Norris Aydil, E. S. Photosensitization of ZnO Nanowires with CdSe Quantum Dots for Photovoltaic Devices. *Nano Lett.* 2007, 7, 1793–1798.
- [38] L., Mora-Seró, S., Giménez, T., F.; Moehl, Fabregat-Santiago, T., Lana-Villarreal, R., J. Gómez, Bisquert, Factors Determining the Photovoltaic Performance of a CdSe Quantum Dot Sensitized Solar Cell: The P. V. Role of the Linker Molecule and of the Counter Electrode. *Nanotechnology* 2008, 19, 424007.
- [39] A., Kongkanand, K., Tvrdy, K., M., Takechi, Kuno, Kamat, Quantum Dot Solar Cells. Tuning Photoresponse through Size and Shape Control of CdSe TiO<sub>2</sub> Architecture. *J. Am. Chem. Soc.* 2008, 130, 4007–4015.
- [40] N., Guijarro, T., Lana-Villarreal, , I., Mora-Seró, J. BisquertGómez, R. CdSe Quantum Dot Sensitized TiO<sub>2</sub> Electrodes: Effect of QD Coverage and Mode of Attachment. *J. Phys. Chem. C* 2009, 113, 4208–4214.
- [41] S., Gorer, G. Hodes., Quantum-Size Effects in the Study of Chemical Solution Deposition Mechanisms of Semiconductor Films. *J. Phys. Chem.* 1994, 98, 5338–5346.
- [42] S., Gorer, G., Hodes, Studies in Surface Science and catalysis 1996, 103, 297.
- [43] S.; Gorer, G., Hodes, Journal of Physical Chemistry 1994, 98, 5338.
- [44] H., Weller, Adv. Mater. 1993, 5.
- [45] R., Vogel, P., Hoyer, H., Weller, J. Phys. Chem. 1994, 98, 3183.
- [46] G., Hodes, Comparison of Dye- and Semiconductor-Sensitized Porous Nanocrystalline Liquid Junction Solar Cells. *J. Phys. Chem. C* 2008, 112, 17778–17787.
- [47] A. Henglein, Ber. Bunsenges. Phys. Chem. 1995, 99, 903.
- [48] J. B. Baxter, E. S. Aydil, Sol. Energy Mater. Sol. Cells 2006, 90, 607.
- [49] N. Robertson, Angew. Chem. Int. Ed. 2006, 45, 2338.
- [50] G. E. Tulloch, J. Photochem. Photobiol., A 2004, 164, 209.
- [51] S. Deb, K, Sol. Energy Mater. Sol. Cells 2005, 88, 1.
- [52] R. J. Ellingson, J. B. Asbury, S. Ferrere, A. N. Ghosh, T. Lian, A. J. Nozik, Phys. Chem. 1999, 212 77
- [53] K. Hara, T. Horiguchi, T. Kinoshita, K. Sayama, H. Sugihara, H. Arakawa, Sol. Energy Mater. Sol. Cells 2000, 64, 115.
- [54] D. C. Olson, J. Pirisa, R. T. Collinsb, S. E. Shaheena, D. S. Ginleya, Thin Solid Films 2006, 496, 26. .
- [55] K. Tennakone, G. R. R. Kumara, I. R. M. Kottegoda, V. S. P. Perera, Chem. Commun. 1998, 10, 3825.
- [56] T. Oekermann, T. Yoshidaa, H. Tadac, H. Minour, Thin Solid Films 2006, 511-512, 354.
- [57] K. Sayama, H. Suguhara, H. Arakawa, Chem. Mater. 1998, 10, 3825.
- [58] M. Graetzel, Nature 2001, 414, 338.
- [59] Y.-L. Lee, Y.-S. Lo, Adv. Funct. Mater. 19 (2009) 604.
- [60] S. Giménez, I. Mora-Seró, L. Macor, N. Guijarro, T. Lana-Villarreal, R. Gómez, L.J. Diguna, Q. Shen, T. Toyoda, J. Bisquert, Nanotechnology 20 (2009) 295204.
- [61] J. Seo, W. J. Kim, S. J. Kim, K. Lee, A. N. Cartwright, and P. N. Prasad, Appl. Phys. Lett. 94, 133302 (2009)
- [62] P. Sudhagar, Hyukjung June ; Park Suil (2009) Electrochemical acta; vol. 55:1; p. 113-117
- [63] L. B. Roberson, M. A. Poggia, J. Kowalik, G. P. Smestad, L. A. Bottomley, L. M. Tolberta, Coord. Chem. Rev 2004, 248, 1491.
- [64] M. Graetzel, Curr. Opin. Colloid Interface Sci. 1999, 4, 314.
- [65] D. Gebeyehu, N. S. Sariciftcia, D. Vangeneugden, R. Kieboomsb, D. Vanderzandeb, F. Kienbergerc, H. Schindler, Synth. Met. 2001, 125, 279.
- [66] D. Gebeyehu, C. J. Brabec, N. S. Sariciftci, Thin Solid Films 2002, 403-404, 271.
- [67] J. Hagen, W. Schaffrath, P. Otschik, R. Fink, A. Bacher, H.-W. Schmidt, D. Haarer, Synth. Met. 1997, 89, 215.
- [68] K. Hara, T. Horiguchi, T. Kinoshita, K. Sayama, H. Arakawa, Sol. Energy Mater. Sol. Cells 2001, 70 151.
- [69] L. H. Slooff, M. M. Wienk, J. M. Kroon, Thin Solid Films 2004, 451-452, 634.
- [70] Y.-J. Lin, L. Wang, W.-Y. Chiu, Thin Solid Films 2006, 511-512, 199.

- [71] A. F. Nogueira, C. Longo, M.-A. De Paoli, *Coord. Chem. Rev.* 2004, 248, 1455.
- [72] P. Qin, X. Yang, R. Chen, L. Sun, *J. Phys. Chem. C* 2007, 111, 1853.
- [73] B. Bowerman, V. Fthenakis, United States Department of Energy, New York, 2001.
- [74] L. Bay, K. West, B. Winther-Jensen, T. Jacobsen, *Sol. Energy Mater. Sol. Cells* 2006, 90 341.
- [75] G. P. Smestad, M. Graetzel, *J. Chem. Educ.* 1998, 75, 752.
- [76] R. E. A. Dillon, D. F. Shriver, *Chem. Mater.* 1999, 11, 3296.
- [77] M. Telford, *Materials Today* 2005, July/August, 15.
- [78] M. Graetzel, *J. Photochem. Photobiol., C Photochem. Rev.* 2003, 4, 145.
- [79] H. Tributsch, *Coord. Chem. Rev.* 2004, 248, 1511.
- [80] W. Kubo, K. Murakoshi, T. Kitamura, Y. Wada, K. Hanabusa, H. Shirai, S. Yanagida, *Chem. Lett.* 12 (1998) 1241.
- [81] Y. Ren, Z. Zhang, E. Gao, S. Fang, S. Cai, *J. Appl. Electrochem.* 31 (2001) 445.
- [82] W. Kubo, T. Kitamura, K. Hanabusa, Y. Wada, S. Yanagida, *Chem. Commun.* 4 (2002) 374.
- [83] C.-H. Chang, Y.-L. Lee, *Appl. Phys. Lett.* 91 (2007) 053503.
- [84] S. A Haque, Y Tachibana,.; R Willis,.; L.; Moser, J. E.; Gratzel, M.; Klug, D. R.; Durrant, J. R. *Journal of Physical Chemistry B* 2000, 104, 538.
- [85] K., Kalyanasundaram, M. Grätzel, *Coord Chem Rev* 1998, 177, 347.
- [86] J., Krüger, U., Bach, M., Grätzel, *Adv. Mater.* 2000, 12, 447.
- [87] G. R. R. A., Kumara, K., Tennakone, V. P. S., Perera, A., Konno, S., Kaneko, M., Okuya, J. *Phys. D: Appl. Phys.* 2001, 34,868.
- [88] X.-t.; Zhang, I Sutanto,.; Taguchi, T.; Tokuhiko, K.; Meng, Q.-b.; Rao, T. N.; Fujishima, A.; Watanabe, H.; Nakamori, T.; Uragami, M. *Solar energy materials and solar cells* 2003, 80, 315.
- [89] A.;Kay, M. Grätzel, *Chem Mater.* 2002, 14, 2930.
- [90] Y. Diamant, S. G Chen,.; , O. A. J MelamedZaban *Phys. Chem. B* 2003,107, 1977.
- [91] Y. J. Liu, H. Z. Yu, *Journal of Physical Chemistry B* 2003, 107, 7803.
- [92] Y. Selzer, A. Salomon, Cahen, D. *Journal of the American Chemical Society* 2002, 124, 2886.
- [93] P. Wang, S. M. Zakeeruddin, R. Humphry-Baker, J. E. Moser. M. Grätzel, *Adv. Mater.* 2003, 15, 2101.
- [94] P.;Wang, S. M. Zakeeruddin, J. E Moser, M. K., T. Nazeeruddin, Sekiguchi,.; Gratzel, M. *Nature Materials* 2003, 2, 498
- [96] J. L. Moll, *Physics of Semiconductors*. New York: McGraw-Hill, 1964.
- [97] B. G. Yogi, *Semiconductor Materials: An Introduction to Basic Principles*:Kluwer Academic/Plenum Publishers, 2003.
- [98] S. J. Fonash, *Solar Cell Device Physics*: Academic Press, 1981.
- [99] O. S. Heavens, *Optical Properties of Thin Solid Films*. New York: Academic Press, 1955.
- [100] M. A. Green, *Solar Cells, Operating Principles, Technology and System Applications*: Prentice-Hall Inc, 1982.
- [101] R. F. Hamilton, I N. Wu, C. Xiang, M. Li, F. Yang, M. Wolfarth, D. W Porter, and A. Holian. Synthesis, characterization, and bioactivity of carboxylic acid-functionalized titanium dioxide nanobelts, *Part Fibre Toxicol.* 2014; 11: 43.
- [102] U. A Charles, M. Y. Sulaiman, Z. Ibarahim, N. B. Ibrahim, M. Y. Othman C. H. Lim. Effect of Oxygen On Size Controlled Synthesis of CdSe QDS *Journal of Fundamental Sciences* ISSN 1823-626X Vol. 9, No. 2, 2013.
- [103] W. A. Tisdale, *et al.*, "Hot-Electron Transfer from Semiconductor Nanocrystals,"*Science* vol. 328, pp. 1543-1547, 2010.
- [104] S. Sze, *Physics of Semiconductor Devices*. New York: Wiley & Sons, 1981.
- [105] R. T. Ross and A. J. Nozik, "Efficiency of Hot-Carrier Solar-Energy Converters,"*Journal of Applied Physics*, vol. 53, pp. 3813-3818, 1982.
- [106] A. J. Nozik, "Spectroscopy and hot electron relaxation dynamics in semiconductor quantum wells and quantum dots," *Annual Review of Physical Chemistry*, vol. 52, pp. 193-231, 2001.

#### AUTHORS

**Correspondence Author** – Dr. Charles Ahamefula Ubani, [decharlington@yahoo.com](mailto:decharlington@yahoo.com) or Charles\_4\_christ@yahoo.com; contact: +60166974183

# Preparation and Characterization of CdSe QDs via Pyrolysis of Organometallic Reagent

Ubani Charles Ahamefula

\*Department of Physics, Universiti Kebangsaan Malaysia, Bangi, 43600 Selangor D.E., Malaysia.

**Abstract-** Reproducible synthetic approach for cadmium selenide quantum dot based on the pyrolysis of organometallic reagents injection into a hot non-coordinating solvent is reported. The synthesis of highly crystalline and monodisperse cadmium selenide quantum dots using inexpensive trioctylphosphine-coordinated selenium as precursor produce a discrete homogeneous nucleation under slow growth. The difference in the temperature of the precursor injection spurred the dissimilarity in the nanocrystal growth, crystallinity, shape and particle sizes. Oleic acid was used to protect the cadmium selenide quantum dots against oxidation and photon emission loss while an organic ligand layer trioctylphosphine was used to overcome predominant influences associated with agglomeration. The optical properties, morphological and structural characterization confirmed the formation of monodisperse cadmium selenide quantum dots with 2.09 to 4.90 nanometres size range which was characterized using transmission electron microscopy, field emission scanning electron microscopy, scanning electron microscopy, atomic force microscopy, optical photoluminescence and absorption spectroscopy. The peak-to-peak values, irregularities in the surface texture and the root-mean-square values of the surface roughness of the prepared cadmium selenide quantum dots were determined.

**Index Terms-** Synthesis, Cadmium selenide, Quantum dots, optical spectroscopy, surface texture.

## I. INTRODUCTION

Quantum dots (QDs) are semiconductor nanoparticles that exhibit size and compositionally tunable band gaps that can be engineered to match the absorption of the solar spectrum. The uniqueness of cadmium selenide (CdSe) QDs lies on the tunable band gap over the entire visible spectra by varying the particle sizes. Being size dependent, the nanoparticles respond differently to solar spectrum. This property is visible from the peak emission frequency's extreme sensitivity to both the dot's size and composition. A strong stimulus could cause a valence band electron to take residence in the conduction band resulting in the creation of a positively charged hole in the valence band. The minimum photon energy absorbed by quantum dot particles into the conduction band corresponds to the energy of the band gap. The percentage of absorbed photons that result in emitted photons commonly referred to as quantum yield (QY) is important for QDs and is influenced by nonradiative transition of electrons and holes between energy levels that produce no electromagnetic radiation.

Owing to the photoelectric potential of nanoparticles their incorporation into solar cell fabrication has been intensively investigated [1-3]. Various approaches to CdSe QDs synthesis have also shown notable potential in light emitting devices, bio-tagging, and lasers. Increased interest in the use of QDs is partly due to the progress in chemical synthesis of these particles and their respective surface modification strategies [4-5]. Another feature of QD is their electronic structure which facilitates the generation of electron-hole pairs during photoexcitation. This provides the basis for their use with electrodes [6, 7].

Long-lived electron/hole pair generation allows the ejection of conduction band electrons to the electrode or the injection of electrons from the electrode into the valence band of the particle. Thus, a photo current can be detected which is much enhanced when electron donors or acceptors are present in solution. The specific detail of the QD electronic structure and the excitonic nature of the photoexcited states solely depend on the semiconductor properties and differ significantly across different materials as shown by for example lead selenide (PbSe) and CdSe [8]. The structure of the cadmium selenide - trioctylphosphine (CdSe-TOPO) QDs encompasses three parts; the core is the CdSe, the outside is the vacuum barriers and the TOPO passivation layer is located between them. Experimental results show that the decrease of passivation increases the effective barrier around the CdSe core causing remarkable blue shift [9].

CdSe QDs synthetic approach that relies on the injection of selenium (Se) precursor into a mixture of solvent and ligands has been successful. This strategy entails precise temperature control to separate the nucleation and growth of the QDs which solely depend on the temperature of the mixture, injection process utilized as well as the concentration gradient under control [10]. It has been reported that room temperature injection of cadmium acetate and sodium seleno-sulphite ( $\text{Na}_2\text{SeSO}_3$ ) in oleic acid showed controlled fluorescence of CdSe QDs [11]. Murcia et al. [12] reported sono-chemical synthesis of CdSe quantum dots using TOPO, cadmium acetate and hexadecylamine. Mono-disperse zinc blende CdSe QDs ranging from 2.5 nm to 4.3 nm have been synthesized in an open-

air microfluidic reactor with polytetrafluoroethylene (PTFE) capillaries as the reaction channels [13] which is comparable to the synthesis reported here (2.09 nm to 4.90 nm).

In this paper, we present the synthesis of CdSe via pyrolysis of organometallic reagents injected into a hot non-coordinating solvent and the characterization of the optical and microstructural properties. Octadecene (ODE) is used as the non-coordinating solvent while oleic acid (OA) is used to protect the CdSe QDs against oxidation and emission loss. ODE as a solvent for the CdSe QDs possesses excellent properties. ODE is stable in air and has a low melting point (below 20 °C) and this makes it easier to be handled at room temperature. Besides, it has a high boiling point (about 360 °C) coupled with its inert nature to the Se precursor, less toxicity, low cost and good dissolving power makes it an ideal solvent for the growth of high quality QDs [14].

To improve the optical properties of CdSe QDs, they are covered with TOPO so as to overcome the predominant defects associated with QDs such as agglomeration. The synthetic route employed was compatible with ODE as solvent which is cheap and environmentally friendly. Oleic acid is used instead of the costlier heteropolyacid (HPA) or thiodipropionic acid TDPA [15] to dissolve CdO powder to form homogeneous cadmium oleate solution and also as capping ligand for the CdSe QDs which is also compatible with ODE.

## II. EXPERIMENT

### A. Material

Organometallic selenium (Se, SCR, 99.5+%, Sigma-Aldrich), with trioctylphosphine (TOPO, Fluka, 90%) and octadecene (ODE, Fisher, 90%) were used to prepare the precursor. The pyrolytic solution comprises metal base cadmium oxide (CdO, SCR, 99.9+%, Sigma-Aldrich), oleic acid (OA, SCR, 90%, Sigma-Aldrich) and octadecene. All the materials were not subjected to further purification or treatment and were stored at 23 °C.

### B. Methodology

The CdSe QDs synthesis follows two different steps; firstly, the preparation of the selenium (Se) precursor and secondly, the preparation of CdSe QDs. Different reaction times were chosen to obtain different sizes of the CdSe QDs.

### C. Selenium solution

30mg of Se powder and 5 ml ODE were added to a 10 ml flat bottom flask over a stirrer hot plate at a temperature of 90 °C in a fume hood. Using a syringe, 0.4 ml TOPO from its sure-seal bottle was added to the flask. A magnetic stirrer bar was added to stir-heat the solution to completely dissolve the Se after which the mixture was cooled to room temperature. The solution was stored in a sealed container for one week to allow the precursor to form.

### D. Synthesis of CdSe QDs

13 mg of CdO was added to 25 ml round bottom flask clamped onto a heating mantle. This operation was done in a fume hood to avoid inhalation hazard associated with cadmium compound. To the same flask, pipette was used to add 0.6 ml OA and 10 ml ODE. The cadmium solution was heated until its temperature reached 195 °C. A clean dry Pasteur pipette was used to quickly transfer 1 ml of the one week old room temperature selenium solution into the hot cadmium solution. The introduction of selenium precursor into the heated solution evolved smoke as the CdSe QDs were rapidly formed. The samples were removed at 10 seconds intervals using a 9 inch glass Pasteur pipette as the CdSe particles grew in size. The samples were synonymous with colour transition from light red to dark brown corresponding to different reaction time. We noted the observable property transitions before and after the formation of CdSe QDs as listed in Table 1.

**Table 1:** Observational changes in visible transition to CdSe QDs formation

	Before	After
<b>Selenium solution</b>		
Colour	Black	Transparent after one week
Appearance	Colloidal	Homogenous
Solution	Heterogeneous	Sticky transparent liquid
<b>CdO</b>		
Colour	Dark brown	Orange at 195 °C
Appearance	Viscous colloidal	Homogenous at 195 °C
In Solution	Heterogeneous	Oily at 195 °C
<b>CdSe</b>		
Colour	_____	Light red to dark brown
Texture	_____	Oily jelly-like



**E. Sample Characterization**

A one-cm path length quartz cuvette was used for the spectral study. Perkin Elmer Lambda-20 UV-vis spectrometer was used to carry out the optical measurement in the range of 200 – 800nm wavelength at room temperature. The absorption peaks were signatory of CdSe QDs. The photoluminescence spectra were recorded on Perkin Elmer Ls-55 Luminescence Spectrometer with xenon lamp over 350 – 700 nm range. For scanning electron microscopy and atomic force microscopy samples, transparent glass measuring 25.2 x 22.2mm having thickness of 1mm to 1.2mm was ultrasonically cleaned with distilled water for 10 minutes. The cleaning process was continued with methanol. The ultrasonically cleaned glass was dried in nitrogen gas to keep moisture away from the glass.

The atomic force microscopy technique shows three-dimensional images including surface roughness, grain size, step height and pitch of CdSe QDs sample surface topography and allows us to view the QDs distributions with a resolution similar to that obtained with scanning electron microscopy. Using the technique, surface parameters such as the peak-to-peak value, average surface roughness and surface root-mean-square values were determined. The technique was used for CdSe nanoparticles samples at room temperature and atmospheric pressure. The transmission electron microscopy and field emission scanning electron microscopy were used to study the micro-structure of the CdSe QDs. The transmission electron microscopy analysis was carried out using CdSe QDs solution. For field emission scanning electron microscopy analysis, a drop of CdSe QDs was dried at room temperature using carbon-copper grid in ODE dispersed solution.

**III. RESULTS AND DISCUSSIONS**

The UV-vis absorption and photoluminescence emission spectra of CdSe nanocrystals with diameter in the range of 2.09 to 4.90 nm are shown in Figs. (1a), (1b) and the mismatch in the optical absorption peak and PL emission of sample withdrawn at the same time shown in (1c) respectively. The illustration in Fig. (1a) shows that the absorption spectrum of CdSe QDs is a function of the growth time. The numbering shown on the absorption peaks (Fig. 1a) illustrates the transition in size range (1 represent the smallest and 6 the largest) as the temperature of the CdSe QDs increases. The colour of the CdSe QDs changes from light red to dark-brown in 1 min with respect to the discharge time. The fast colour transition in the CdSe QDs indicated rapid nuclei growth and this was verified by the corresponding absorption peak shift. The small CdSe QDs with an absorption peak at 482 nm was formed in 10 s and grew bigger QDs with an absorption peak at 542 nm in 1 min. The increase in size with respect to time as the peak shifts to longer wavelength was a result of transition in the interband of the CdSe QDs [16]. It became obvious that the particle size of CdSe QDs can be tuned by varying the reaction time.

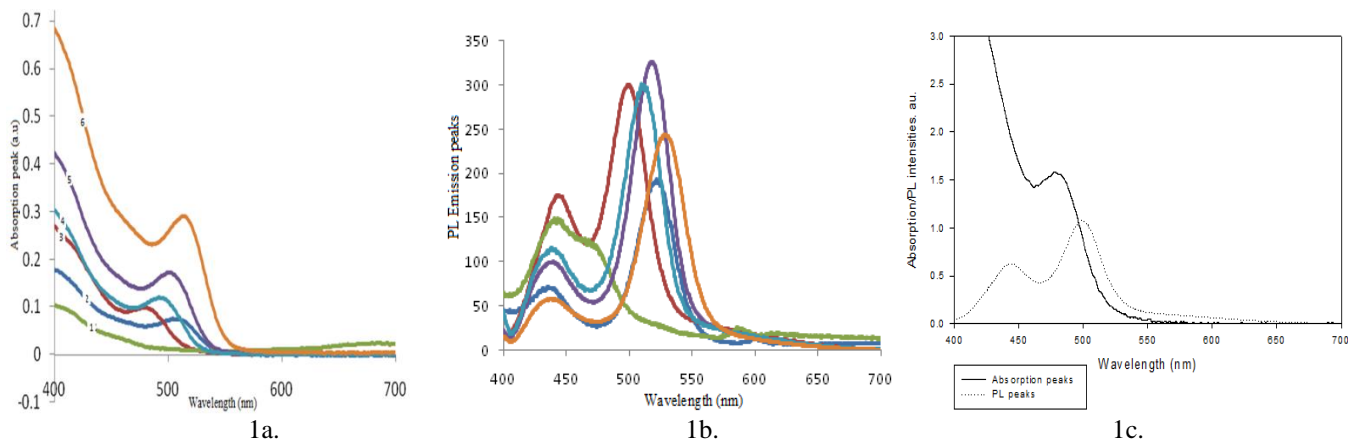


Fig. 1 a) depicts the optical absorption of the synthesized CdSe QDs; b) PL emission peaks of different particle sizes; c) Peak mismatch of the optical absorption peak and PL emission peak of CdSe QDs.

The corresponding photoluminescence spectra of the CdSe nanocrystals in Fig. (1b) show the extension time of reaction which is obvious with emission wavelength shifts from 442 nm to 533 nm. The intensity of the photoluminescence peak for the CdSe QDs increased with increase in the growth time in 1 min. In addition, the photoluminescence peak was broad and asymmetric initially and became narrower and symmetric as the reaction time increased. Similar nanocrystal size distribution was reported by Peng et al [17] where 1.5 min reaction time resulted in the increase of particle size owing to the depletion of the monomer concentration in the reaction solution. The photoluminescence properties of CdSe QDs are important because the tunability of the emission wavelength and nanocrystal size which is a signatory of the peaks could influence their applications since their optoelectronics properties are size-

related. The peak difference between the absorbed and emitted photons as illustrated in Fig. (1c) was thought to be caused by thermal losses. Spectral relationship of UV-vis and photoluminescence in Fig. 1c shows that the photoluminescence spectra are typical of CdSe QDs consisting of two peaks: one with the position closer to the absorption peak called band-edge photoluminescence and the other is red-shifted peak referred to as trap-related photoluminescence.

Scanning electron microscopy (SEM) diffraction pattern of the CdSe QDs given in Fig. (2) shows regular repeating pattern of CdSe QDs image. Each bright spot corresponds to the crystal plane and the symmetry of the spot speaks of the crystal structure.

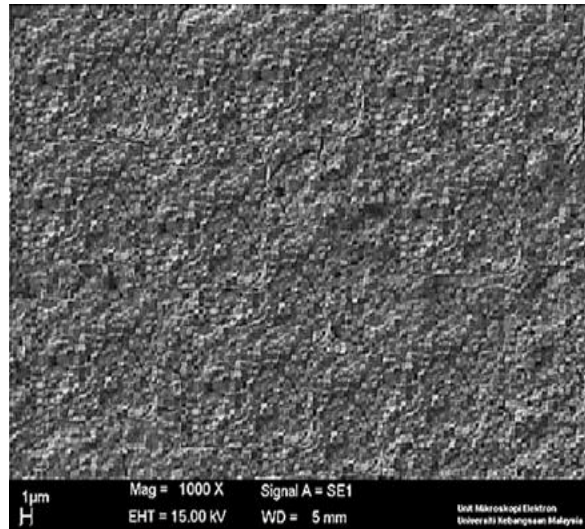
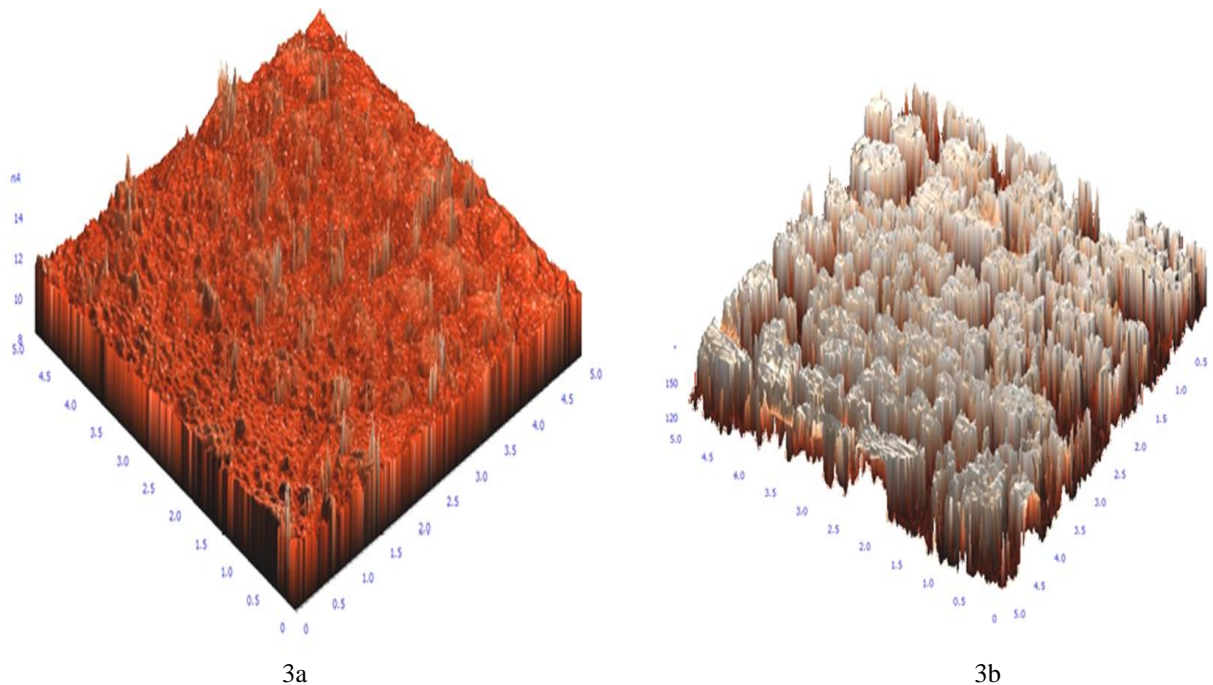


Fig. 2 SEM microstructure image of CdSe QDs

Figs. 3 shows AFM microstructure images of the synthesized CdSe QDs. 3(a) depicts 3D image of CdSe QDs annealed at 350 °C; 3(b) 3D image of CdSe QDs in octadecene solution and Fig. 3(c) shows the surface morphology; Fig. 3(d) shows the sensheight histogram based on which the surface profile information where obtained. For ten point count height of the atomic force microscopy images with scan size of 609.1 nm containing 65536 CdSe nanoparticles, the peak-to-peak value is 1218.7 nm, surface skewness is -0.04 and surface kurtosis is -1.23. The irregularities in the surface texture associated with surface roughness have an average value of 265.7 nm with the surface root-mean-square value of 303.94 nm.



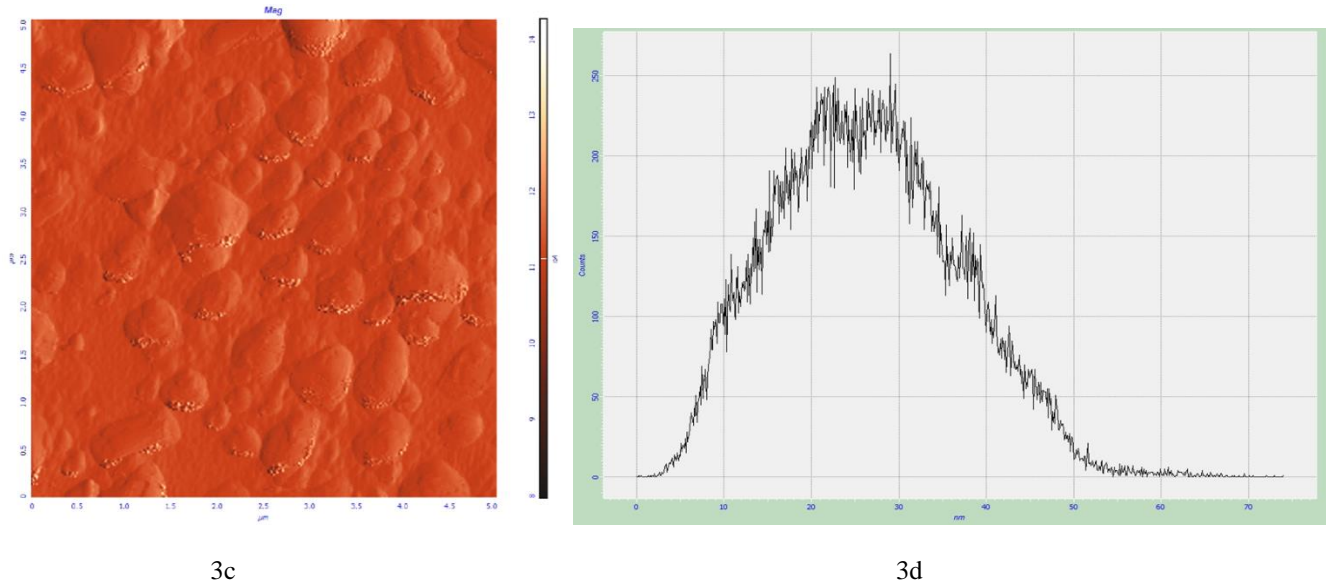


Fig. 3 AFM 3D microstructure image analysis

Figs. 4(a) and 4(b) show the transmission electron microscopy (TEM) and field emission scanning electron microscopy (FESEM) images of the CdSe QDs with respect to the successive lattice spacing. The transmission electron microscopy image reveals that the QD size distribution possesses almost spherical morphology. The spacing of the lattice plane obtained from TEM analysis depicting particle size spacing is as shown in Fig. 5.

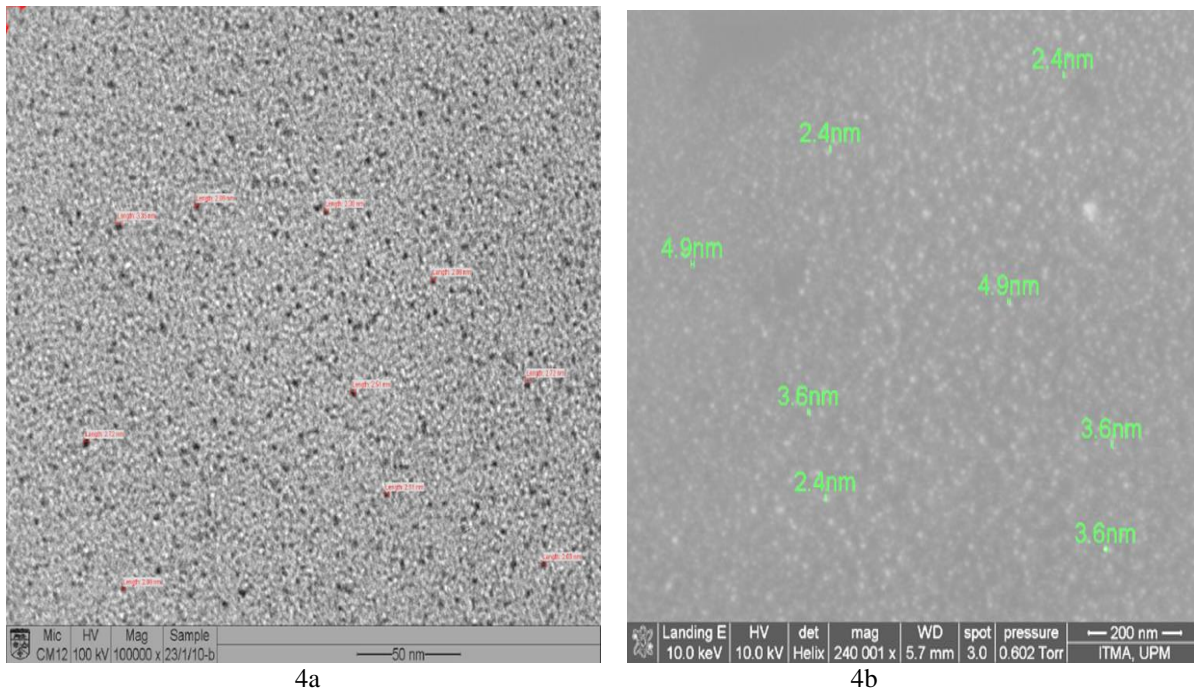


Fig. 4a Depicts TEM cross-sectional analysis and Fig. 4b Depicts FESEM surface image of the CdSe QDs



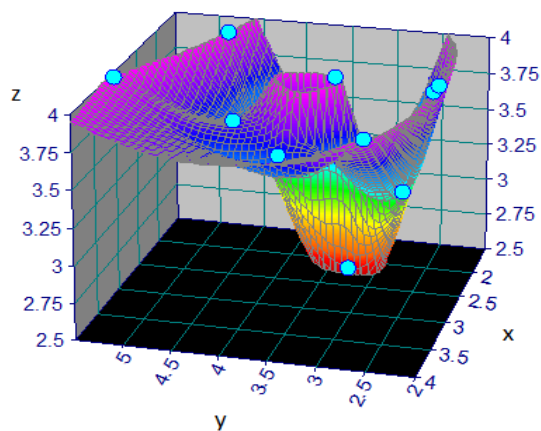


Fig. 5

Fig. 5 CdSe QDs particle spacing

#### IV. CONCLUSION

We demonstrate cheap and efficient method for CdSe QDs synthesis via pyrolysis of organometallic reagents. Despite the low cost, the synthesis produced high quality CdSe QDs. The synthesized CdSe nanocrystals showed a relatively narrow size distribution with particles size ranging from 2.09 nm to 4.9 nm. OA was used to protect the CdSe QDs from oxidation and emission loss. Their vulnerability to this effect degrades the photoluminescence quantum yield of nanocrystals semiconductors. The organic ligand layer TOPO was added to improve the optical properties of the CdSe QDs. Spectral relationship of UV-vis and photoluminescence shows that the photoluminescence spectra are typical of CdSe QDs consisting of two peaks; one with the position near the absorption peak called band-edge photoluminescence and the other red-shifted referred to as trap-related photoluminescence.

The quantitatively analyzed CdSe QDs surface parameters for ten point count height of atomic force microscopy images with scan size of 609.1 nm containing 65536 CdSe nanoparticles have peak-to-peak value of 1218.7 nm, surface skewness of -0.04 and surface kurtosis of -1.23. The irregularities in the surface texture have an average value of 265.7 nm and a surface root-mean-square value of 303.9 nm. We estimated the surface roughness, grain size, step height and pitch of the CdSe QDs sample. The surface topography reveals the particle distributions with the resolution similar to that obtained with scanning electron microscopy. The scanning electron microscopy reveals surface alignment of the QDs. Transmission electron microscopy and field emission scanning electron microscopy images show the lattice spacing. The transmission electron spectroscopy illustrated size distribution pattern of the CdSe QDs, its spherical morphology and the lattice plane spacing.

#### REFERENCES

- [1] C.A.J. Lin, T. Liedl, R.A. Sperling, M.T. Fernandez-Arguelles, J.M.Costa-Fernandez, R. Pereiro, A. Sanz-Medel, W.H. Chang, W.J. Parak, Bioanalytics and biolabeling with semiconductor nanoparticles (quantum dots), *J. Mater. Chem.* 17 (2007) 1343-1346.
- [2] E. Katz, I. Willner and J. Wang, Electroanalytical and bioelectroanalytical systems based on metal and semiconductive nanoparticles, *Electroanalysis* 16 (2004) 19-44.
- [3] R. H. Baughman, A. A. Zakhidov, and W. A. de Heer, Carbon nanotubes-the route toward applications, 297 (2007) 787-792. B. Smith, "An approach to graphs of linear forms (Unpublished work style)," unpublished.
- [4] A.R. Clapp, I.L. Medintz, H.T. Uyeda, B.R. Fisher, E.R. Goldman, M.G. Bawendi, H. Mattoussi, Quantum Dot-Based Multiplexed Fluorescence Resonance Energy Transfer, *J. Am. Chem. Soc.* 127 (2005)18212-18221.
- [5] W. C. W.Chan, D. J. Maxwell, X. Gao, R. E. Bailey, M. Han and N. Shuming, Luminescent quantum dots for multiplexed biological detection and imaging, *Current Opinion in Biotechnology* 13 (2002) 40-46.
- [6] E .P .A .M. Bakkers, A. L. Roest, A .W. Marsman, L .W. Jenneskens, L. I. de Jong-van Steensel, J. J. Kelly and. D. Vanmaekelbergh, Factors determining the photovoltaic performance of a CdSe quantum dot sensitized solar cell: the role of the linker molecule and of the counter electrode, *J. Phys. Chem. B*, 104 (2000) 7266 – 7272.
- [7] S .N. Sharma, Z. S. Pillai and P .V. Kamat, Photoinduced Charge Transfer between CdSe Quantum Dots and p-Phenylenediamine, *J. Phys. Chem. B*, 107 (2003)10088 – 10093.
- [8] O.V. Prezhdo and P.J. Rossky, Relationship between Quantum Decoherence Times and Solvation Dynamics in Condensed Phase Chemical Systems, *Phys. Rev. Lett.* 81 (1998) 5294–5297.
- [9] Z.F. Mao and B. Wu, Health Behaviours and Socioeconomic Status, *Hubei Health Services Survey*, (2005) 140-153.
- [10] C.B. Murray, C.R. Kagan and M.G. Bawendi, Synthesis and Characterization of Monodisperse nanocrystals and close-packed nanocrystal assemblies, *Annu. Rev. Mater. Sci.* 30 (2000) 545–610.

- [11] W. Liu, M. Howarth, A.B. Greytak, Y. Zheng, D.G. Nocera A.Y. Ting, M.G. Bawendi, Compact Biocompatible Quantum Dots Functionalized for Cellular Imaging, *J. Am. Chem. Soc.* 130 (2008) 1274 -1284.
- [12] P. Alivisatos, The use of nanocrystals in biological detection. *Nature Biotechnology* 22 (1) (2004) 47-52.
- [13] W. Luan, H. Yang, S. Tu, and Z. Wang, Open-to-air synthesis of monodisperse CdSe nanocrystals via microfluidic reaction and its kinetics, *Nanotechnology* 18 (2007) 175603.
- [14] M.W. Yu and X.G. Peng, Formation of high-quality CdS and other II-VI semiconductor nanocrystals in noncoordinating solvents: tunable reactivity of monomers, *Angew Chem. Int. Ed.* 41 (13) (2002) 2368-2371.
- [15] Z. A. Peng and X. G. Peng, Formation of High-Quality CdTe, CdSe, and CdS Nanocrystals Using CdO as Precursor, *J. Am. Chem. Soc.* 123 (1) (2001) 183–184.
- [16] S. Kim, B.R. Fisher, H.J. Eisler, and M.G. Bawendi, Type II Quantum Dots: CdTe/CdSe (Core/Shell) and CdSe/ZnTe(Core/Shell) Heterostructures, *J. Ame. Chem. Soc.* 125 (2003)11466-11467.
- [17] X.G. Peng, J. Wickham and A.P. Alivisatos, Kinetics of II-VI and III-V colloidal semiconductor nanocrystal growth: Focusing of size distributions, *J. Ame. Chem. Soc.* 120 (21) (1998) 5343-5344.

AUTHOR

**Correspondence Author** – Dr. Charles Ahamefula Ubani, [decharlington@yahoo.com](mailto:decharlington@yahoo.com) or Charles\_4\_christ@yahoo.com; contact : +60166974183



# Epidemiological and Microbiological Profile of Infectious Corneal Ulcers in Tertiary Care Centre, Kumaon Region, Uttarakhand

Dr Laltanpuia Chhange, \* Dr Shanti Pandey, \* Dr Umesh \*\*

\*Department of Ophthalmology, GMC, Haldwani

\*\*Department of Microbiology, GMC, Haldwani

**Abstract- Purpose:** To determine the epidemiological pattern, clinical presentation and risk factors involved in infectious corneal ulceration in Tertiary Care Centre, Kumaon region, Uttarakhand and to identify the specific microbial agents responsible for corneal infections.

**Methods:** All patients with suspected microbial keratitis presenting to the OPD, Department of Ophthalmology, GMC, Haldwani from November 2012-August 2014 were evaluated. Sociodemographic data and information pertaining to the risk factors, clinical presentation were recorded. After diagnosing infective corneal ulcer clinically, corneal scraping and cultures were performed.

**Results:** Over the study period, 76 patients with suppurative keratitis were evaluated. Ocular trauma was the most common predisposing factor in 55 (72.4%) patients ( $p = 0.001$ ), followed by co-existing ocular disorder in 7 (9.2%) patients. Cultures were positive in 52 (68.4 %) patients. Among these culture positive vases, 31 (40.7%) patients had pure fungal infection, 19 (25%) had pure bacterial infections and 2 (2.6%) had mixed fungal and bacterial infections. The most common fungal pathogen was *Aspergillus* spp representing 18 (54.5%) of all positive fungal cultures, followed by *Fusarium* spp in 11 (33.3%) instances. The most common bacterial isolate was *Staphylococcus aureus*, representing 9 (42.8%) of all the bacterial culture followed by *Coagulase negative Staphylococci(CONS)* 6 (28.6%). *Nocardia* spp was detected in 1(1.3%) patient.

**Conclusion :** Infective Keratitis in Kumaon region, Uttarakhand most often occurs after a superficial trauma with vegetative or organic materials. Fungal ulcers were more common than bacterial ulcers. *Aspergillus* spp and *Staphylococcus aureus* were the most common fungus and bacteria respectively. These findings have important public health implications for the treatment and prevention of suppurative corneal ulceration in this region of India.

**Index Terms-** Suppurative Keratitis, Microbial keratitis, infectious keratitis, corneal ulceration

cause of monocular blindness after unoperated cataract in some developing countries in the tropics.<sup>3-6</sup> The incidence of microbial keratitis varies from 11 per 100,000 persons/year in the United States to 799 per 100,000 persons/year in Nepal.<sup>7,8</sup> The reported incidence of corneal ulceration in India is 1130 per million population.<sup>9</sup>

The prevalence of blindness directly resulting from complications of suppurative keratitis is estimated to be 5%; the associated ocular morbidity is the result of several factors and patients management is directly affected by the lack of diagnostic facilities and initiation of appropriate antimicrobial therapy. Specific treatment requires quick and accurate identification of the causative microorganisms.<sup>10</sup> Corneal blindness is responsible for 1.5 to 2 million new cases of monocular blindness every year in which ocular trauma and corneal ulceration are significant factors.<sup>6</sup>

The epidemiological pattern and causative agents for suppurative corneal ulcer varies significantly from country to country, and even from region to region within the same country. It is important to determine the "regional" aetiology within a given region for comprehensive strategy for the diagnosis and treatment of corneal ulcer.<sup>10</sup> Infectious corneal ulcer is associated with some predisposing factors. Ocular trauma is a far more common predisposing of infectious Keratitis in developing countries, whereas pre-existing ocular disease and contact lens are common risk factors in developed countries.<sup>1</sup>

In a vast agricultural country like India, particularly where primary health care and referral systems are weak, minor eye injuries sustained in agricultural farms often lead to infectious corneal ulceration and loss of vision.<sup>11</sup>

The purpose of this study was to evaluate all suppurative keratitis seen at Tertiary Care Center, Kumaon region, Uttarakhand over a period of 2 years from November 2012 to August 2014. We also attempted to search for the antecedent risk factors predisposing to the development of suppurative keratitis and to identify the specific microorganisms responsible for infections. This will help in management of such cases in this region.

## I. INTRODUCTION

Corneal ulcer is a potentially sight threatening ocular condition and the leading cause of monocular blindness. It can be caused by various pathogens i.e., bacteria, fungi, virus and parasites.<sup>1</sup> Bacteria and fungi is the main cause of unilateral corneal scar.<sup>2</sup> *Suppurative Keratitis* is the second most common

## II. MATERIALS AND METHODS

### Patients

All patients with infectious corneal ulcers presenting to the OPD, Department of Ophthalmology, GMC, Haldwani, Uttarakhand from November 2012 to August 2014 were included

in the study. Patients were seen consecutively after the initial clinical diagnosis of corneal ulceration was made. Ulceration was defined as a loss of the corneal epithelium with underlying stromal infiltration and suppuration associated with signs of inflammation with or without hypopyon. Typical viral ulcers and non-healing ulcers were excluded as were Mooren's ulcers, marginal ulcers, interstitial keratitis, sterile neurotrophic ulcers, and any ulcers associated with autoimmune conditions. A standardised form was filled out on each patient documenting socio-demographic information as well as clinical information including duration of symptoms, previous treatment, predisposing ocular conditions, and associated risk factors.

### Clinical procedures

The visual acuity was measured in a standard manner. All patients were examined under slit lamp biomicroscope by ophthalmologist. The size of the ulcer was measured after staining with wet sterile fluorescein paper strip using the variable slit on the slit lamp and recorded in millimetres, also pictures of which recorded with the help of mobile slit lamp adaptor. In a similar way, size of the stromal infiltrate and depth of the lesion was recorded. Ulcer margin, floor, thinning, satellite lesions, pigmentation on the ulcer surface, any impacted lesions, pigmentation on the ulcer surface, any impacted foreign body were noted. The presence of hypopyon was recorded and its height was measured in millimetres. Any associated ocular condition like trichiasis/entropion, Blepharitis, Bell's palsy, lagophthalmos, chronic dacryocystitis, dry eyes, corneal anaesthesia, bullous keratopathy, spheroidal degeneration of the cornea, any surgery on the cornea, use of contact lens, or ocular leprosy was also noted. The use of topical medications including topical corticosteroids were also noted.<sup>9,12</sup>

Corneal scraping was performed under strict aseptic conditions by an ophthalmologist using a sterile Bard-Parker blade (No15).<sup>12,13</sup> The procedure was performed under magnification of a slit lamp or binocular surgical loupe following instillation of preservative free 2% lignocaine hydrochloride. Material obtained from scraping of the leading edge and base of each ulcer was inoculated directly in the media and smeared onto two slides, one stained with Gram stain and the other with 10% Potassium hydroxide (KOH) for direct microscopic evaluation.<sup>10</sup>

### Laboratory procedures

All bacterial cultures were incubated aerobically at 37 °C. Cultures on blood agar and chocolate agar were evaluated at 24 hours and at 48 hours and then discarded if there was no growth.

Fungal cultures inoculated onto SDA were incubated at 27 °C, examined daily, and discarded at 2 weeks if no growth was present. Cultures on non nutrient agar overlaid with *E. coli* were examined daily for the presence of *Acanthamoeba* spp and likewise discarded at 1 week if there were no signs of growth.

Microbial cultures were considered positive only if growth of the same organism was demonstrated on two or more solid media; or there was semiconfluent growth at the site of inoculation on one solid medium associated with the identification of the organism of appropriate morphology and staining characteristics on Gram or Giemsa stained corneal smears.<sup>10</sup> The specific identification of bacterial pathogens was based on microscopic morphology, staining characteristics, and biochemical properties using standard laboratory criteria. Fungi were identified by their colony characteristics on SDA and by the morphological appearance of the spores in lactophenol cotton blue stain. If by microscopy in KOH mount preparation, hyphae were observed in corneal smear, but failed to grow in culture, the causative organism was reported as fungal. All laboratory methods followed standard protocols which have been discussed in detail in a previous report.<sup>4,9,10,12</sup>

## III. RESULTS

### Epidemiological Characteristics

76 patients with the clinical diagnosis of corneal ulcer with or without hypopyon were enrolled for this study. 44 (57.9%) patients were males and 32(42.1%) were females. In both groups, keratitis occurred most frequently (60:78.9%) in the age group 21-65 years. Majority of the patients (59:77.6%) were from rural areas. The majority (53:69.7%) were labourers/farmers or homemakers, usually working in paddy fields in this region. A majority of the patients (33:43.4%) were seen between 2-3 weeks of their illness at our hospital and 17(22.4%) patients reported after 4 weeks. There was a significant increase in patients during the month of November and December (20:26.3%) and July and August (17:22.4%). (Table 1) Previous treatment was already taken by 67 (88.1%) patients before their first visit to us.

Of the patients who were on some form of topical medication (n=67), 53(69.7%) were taking antibiotic drops (ciprofloxacin, tobramycin, ofloxacin, chloramphenicol, gentamycin), 10(13.2%) patients were taking antifungal eye drops (natamycin or itraconazole), 3(3.9%) were on topical corticosteroids and 2(2.6%) were on some local drugs.

Demographics	Particulars	n (%)
Sex	Male	44(57.9)
	Female	32(42.1)
Age in Years	<20	9(11.8)
	21-40	23(30.3)
	41-65	37(53.9)
	>65	7(9.2)
Residence	Rural	59(77.6)
	Urban	17(22.4)
Occupation	Labourers/farmers	27(35.5)

	Homemakers	26(34.2)
	Business/professionals	9(11.8)
	Students/children	12(15.8)
	Others	2(2.6)
First presentation	Within 1 <sup>st</sup> weeks	26(34.2)
	2 <sup>nd</sup> – 3 <sup>rd</sup> week	33(43.4)
	≥ 4 week	17(22.4)
Seasonal Variation	Jan-Feb	7(9.2)
	Mar-Apr	11(14.5)
	May-June	13(17.1)
	July-Aug	17(22.4)
	Sep-Oct	8(10.5)
	Nov-Dec	20(26.3)

**Predisposing factors**

A history of recent corneal injury was obtained in 55(72.4%) patients (p = 0.001) 18(23.7%) patients had corneal injury with vegetative trauma, 11(14.5%) patients had animal injury. Other significant agents were sand/stone, wooden material, flying insect, dirty wire...etc. Ocular problems predisposing to corneal ulcer were present in 7(9.2%) patients. Among them were chronic dacryocystitis, entropion, and trichiasis. 1(1.3%) patient was diabetic patient and 1(1.3%) was using steroids inadvertently. There was no specific history in 12(15.8%) patients. (Table 2) The risks for suppurative keratitis associated with these predisposing conditions were presumptive.<sup>9</sup>

Table 2. Predisposing factors of suppurative corneal ulcers seen at a tertiary care centre in Kumaon region, Uttarakhand

Predisposing factors	n (%)
Trauma	55(72.4)
Vegetative trauma	18(23.7)
Animal matter	11(14.5)
Sand/stone	7(9.2)
Wooden material	7(9.2)
Miscellaneous	12(15.8)
Co-existing ocular disorder	7(9.2)
Co-existing systemic disease	1(1.3)
Inadvertent use of steroids	1(1.3)
No specific history	12(15.8)

**Microbial Diagnosis**

Cultures were positive in 52(68.4%) corneal ulcers. 31(40.7%) patients had pure fungal growth, 19(25%) had pure bacterial growth, 2(2.6%) cases had mixed bacterial and fungal growth and 1(1.3%) was positive for *Nocardia* spp. The remaining 24(31.5%) were culture negative. (Table 3) *Staphylococcus aureus* was the most commonly isolated bacterial organism (9:42.8%) of all positive bacterial cultures. The other isolated gram-positive organisms were *Coagulase negative Staphylococci*(CONS) (6:28.6%) and *Streptococci pneumoniae* (2:9.5%). *Pseudomonas* spp, the most frequently occurring gram-negative organism was isolated from 1(1.3%) culture. The other gram negative organisms were *Acinobacter* spp, *Citrobacter* spp and *Nocardia* spp.(Table 4) Out of the fungal isolates (33:43.4%), 33(57.6%) grew *Aspergillus* spp, 11(33.3%) grew *Fusarium* spp and 2(6.1%) grew *Penicillium* spp. Yeast form, *Candida* spp was positive in 1(1.3%) case. (Table 5)

Table 3. Growth pattern of micro-organisms responsible for corneal ulcers in Kumaon region, Uttarakhand

Type of micro-organism cases	Percentage	No. of
Definite bacterial growth	19	25
Definite fungal	31	40.7
Mixed microbial growth	2	2.6
Patients with positive cultures	52	68.4
Patients with negative cultures	24	31.5
<b>Total No. of suppurative corneal ulcers</b>	<b>76</b>	<b>100</b>

Table 4. Identification of the bacterial isolates from corneal ulcers in Kumaon region, Uttarakhand

Bacteria with fungus	Total(%)	Pure Isolates	Mixed
<b>Gram Positive Organisms</b>			
<i>Staphylococcus aureus</i>	8	1	9(42.8)
<i>Streptococcus pneumoniae</i>	2	0	2(9.5)
<i>Streptococcus pneumoniae</i>	6	0	6(28.6)
<i>CONS</i>	16	1	17(80.9)
<b>Subtotal (%)</b>			
<b>Gram negative organisms</b>			
<i>Pseudomonas</i> spp	1	0	1(4.8)
<i>Pseudomonas</i> spp	1	0	1(4.8)
<i>Acinobacter</i> spp	0	1	1(4.8)
<i>Citrobacter</i> spp	1	0	1(4.8)
<i>Nocardia</i> spp	3	1	4(19.04)
<b>Subtotal (%)</b>			
<b>Total No. of bacterial corneal ulcers</b>	<b>19</b>	<b>2</b>	<b>21(100)</b>

Table 5. Identification of the fungal isolates from corneal ulcers in Kumaon Region

Fungi with bacteria	Total(%)	Pure isolates	Mixed
<i>Aspergillus</i> spp	18	1	19(57.6)
<i>Aspergillus</i>	5	1	6(18.2)
<i>fumigatus</i>	6	0	6(18.2)

<i>Aspergillus flavus</i>	3	0	3(9.1)
<i>Aspergillus niger</i>	4	0	4(12.1)
<i>Aspergillus</i> spp	11	0	11(33.3)
<i>Fusarium</i> spp	0	1	1(3.03)
<i>Candida</i> spp	2	0	2(6.1)
<i>Penicillium</i> spp.			
<b>Total No. of fungal corneal ulcers</b>	<b>31</b>	<b>2</b>	<b>33(100)</b>

#### IV. DISCUSSION

In this study, the commonest age group affected was between 41-65years (37:53.9%), followed by 21-40 years (23:30.3%), <20 years(9:11.8%) and >65 years(7:9.2%) This has a considerable socioeconomic impact because this age group are bread earners of the family. Similar age group was also most commonly affected in south India and western Orissa.<sup>9,14</sup> While in eastern study and Bangladesh study, the commonest age group was 21-40 years.<sup>1,15</sup>

The majority of the corneal ulcer patients (53:69.7%) were agricultural workers/daily wage earners (27:35.5%) or homemakers/housewives (26:34.2%), involved in agricultural activities. Housewives/homemakers (26:34.2%) were more affected in our study because in this region, they were also involved more in agricultural activities and cutting grasses from the forest for animals..etc. But in other studies labourers/farmers contributed ranging from 54-70% and housewives/homemakers 11-13%.<sup>9,15,16</sup> Undoubtedly ocular injury (55:72.4%) was the most common predisposing factor, followed by co-existing ocular disorder (7:9.2%).

Unlike south India (60%), 26(34.2%) patients in this study presented during the first week of their illness.<sup>9,12</sup> Before their first presentation at our hospital, 67(88.1%) patients had consulted health care provider of some kind or local dai or quack. Similar to south india and eastern india, most eye medications are sold over the counter without a prescription till date. A significant increase in the number of cases of suppurative keratitis was observed during harvesting seasons of November-December (20:24.3%) and July-Aug (17:22.4%). Others have noted an increase incidence of fungal keratitis during the dry, windy, harvesting seasons compared with the wet, humid months of the year,10,17-19 and few others have reported an increase during the hot and humid months.<sup>20-22</sup>

In this study 52(68.4%) of 76 corneal scrapings were culture positive. This is similar to reports in Ghana,<sup>10</sup> south india,<sup>9,12</sup> and eastern india,<sup>15</sup> 57.3%, 68.4%, 70.6% and 67.7% respectively. Among these, 31(40.7%) cases were positive for fungus, 2(2.6%) patients with mixed infection. So a total of 33(43.4%) were treated as fungal infection. This is similar to south india reports by Leck at al,<sup>10</sup>(44.1%), Bharathi et al,<sup>12</sup> but lower than Srinivasan et al study<sup>9</sup>(51.9%) and Basak SK et al study<sup>15</sup>(59.3%). It is also lower than the study in Assam, eastern india where the incidence of fungal keratitis was 32%. Mixed infections both by bacteria and fungi was similar to Bharathi et al (2.4%) report from south india,<sup>12</sup> but less as compared to reports by Srinivasan et al(5.1%),<sup>9</sup> Leck et al (5.5%),<sup>10</sup> and Basak SK et al(9.5%).<sup>15</sup>

21(27.6%) were bacteria positive, 25% had pure bacterial infection and 2.6% had a mixed infection. This reduction in bacterial corneal ulcers in general at the referral centres might be attributed to more successful treatment of bacterial corneal ulcers in the periphery since the introduction of topical fluoroquinolones in the late 1990s.<sup>22</sup> Of the 21 bacterial isolates, 42.8% was *Staphylococcus aureus*, which was similar to studies in West Bengal.<sup>15,23</sup> The most common infecting bacteria was *Streptococcus pneumoniae* in Nepal and south India,<sup>4,8,9</sup> and *Pseudomonas* spp in Ghana and Bangladesh.<sup>10,17</sup>

The most commonly isolated fungal pathogens in the current series were *Aspergillus* spp. Of 33 fungal isolates, 57.5% were *Aspergillus* spp, 33.3% were *Fusarium* spp and 6.1% were *Penicillium* spp. In our study, *Candida* spp (1:3.03%) was less compared to other studies.<sup>4,12</sup> *Aspergillus* species were predominant in Mumbai, parts of south India, north india, Nepal and Bangladesh.<sup>4,12,17,24-27</sup> Other studies in south india reported *Fusarium* spp to be more common than *Aspergillus* spp.<sup>10,13,28</sup> *Fusarium* spp have also been found to be the principal fungal pathogen in Florida, Paraguay, Nigeria, Tanzania, Hong Kong and Singapore.<sup>4,29-36</sup> These phenomenon may be explained by differences in climate and the natural environment.

In summary, suppurative keratitis continues to be a cause for concern among the ophthalmologist in Kumaon region, Uttarakhand and it is evident that the predominance of agricultural activity in this hilly Kumaon region is the principal causative factor. This “regional” information is important with regard to empirical management, as many eye clinics in the locality do not have microbiology facilities. It will also help us to formulate guidelines for prevention of suppurative keratitis in the population at risk.

#### REFERENCES

- [1] Sharmeen Ahmed, Anamica Ghosh, Syed A Hassan, Shirin Tarafder, Md. Ruhul Amin Miah et al. Predisposing Factors and Aetiologic Diagnosis of Infectious Corneal Ulcer. Bangladesh J Med Microbiol 2010; 04 (01) : 28-31.
- [2] Guidelines for the Management of Corneal Ulcer at Primary, Secondary and Tertiary Care health facilities in the South- East Asia Region, World Health Organization Bulletin 2004; p6-8.
- [3] Wani MG, Guidelines for the Management of Suspected Microbial Keratitis in Settings with Limited Laboratory Facilities. SSMB, 2008 (Nov); VoI, Issue8; 3-6.
- [4] Upadhyay MP, Karmacharya PC, Koirala S, Tuladhar NR, Bryan LE., Smolin G. et al. Epidemiologic characteristics, predisposing factors, and aetiologic diagnosis of corneal ulceration in Nepal. Am J Ophthalmol 1991;111:92-99
- [5] Gonzales CA, Srinivasan M, Whitcher jP, Smolin G. Incidenc of corneal ulceration in Madurai District, south India. Ophthalmic Epidemiol 1996;3: 159-66.
- [6] Whitchar JP, Srinivasan M, Upadhayay MP. Corneal blindness: a global perspective. Bull World Health Organ 2001;79:214-21.
- [7] Erie JC, Nevitt MP, Hodge DO, Ballard DJ. Incidence of ulcerative keratitis in a defined population from 1950 through 1988. Arch Ophthalmol 1993;111;1665-71.
- [8] Upadhyay MP, Karmacharya PC, Koirala S, Shah DN, Shakiya S, Shrestha JK, et al. The Bhakrapur eye study: ocular trauma and antibiotic prophylaxis for prevention of ocular trauma and antibiotic prophylaxis for prevention of corneal ulceration in Nepal. Br J Ophthalmol 2001;85:388-92.
- [9] Srinivasan M, Gonzales CA, George C et al. Epidemiology and aetiological diagnosis of corneal ulceration in Madurai, South India. Br J Ophthalmol, 1997; 81: 965-971.

- [10] Leck AK, Thomas PA, Hagan M, Kaliyamurthy J, Ackuaku E, John M, et al. Aetiology of suppurative corneal ulcers in Ghana and south India, and epidemiology of fungal keratitis. *Br J Ophthalmol* 2002;86:1211-15.
- [11] Robert C. Arff, Grayson's Diseases of the Cornea, 4th edition, Mosby Publications, p257-269
- [12] Bharathi MJ, Ramakrishnan R, Vasu S, Meenakshi R, Palaniappan R. Epidemiological Characteristics and laboratory diagnosis of fungal keratitis a three year study. *Indian J Ophthalmol* 2003;51:315-21.
- [13] Sharma S, Athmanathan T. Diagnostic procedures in infectious keratitis. In: Nema HV, Nema N, editors, *Diagnostic procedures in Ophthalmology*. Jaypee Brothers Medical Publishers, New Delhi; 2002: pp 232-53.
- [14] Dr Samir Mahapatra, Dr Debendra Kumar Sahu et al. Epidemiological and Microbiological Evaluation of Microbial Keratitis in Western Orissa: A 2 year Prospective Study in a Tertiary Care Centre. *AIOC 2009 Proceedings*: 304-306.
- [15] Basak SK, Basak S, Mohante A, Bhowmick A. Epidemiological and microbiological diagnosis of suppurative keratitis in Gangetic West Bengal, Eastern Indian *J Ophthalmol* 2005; 53 (1) : 17-22.
- [16] Marlon Moraes Ibrahim, Rafael Vanini et al. Epidemiology and medical predication of microbial keratitis in southeast Brazil. *Arq Bras Oftalmol*. 2011; 74 (1) 7-12.
- [17] Williams G, Billson F, Husain R, Howlader SA, Islam N, McCellan K. Microbiological diagnosis of suppurative keratitis in Bangladesh. *Br J Ophthalmol* 1987;71:315-21
- [18] Chander J, Sharma A. Prevalence of fungal corneal ulcers in norther india. *Infection* 1994;22:207-09.
- [19] Thylefors B. Epidemiological patterns of ocular trauma. *NZ J Ophthalmol* 1992;20:95-98.
- [20] Kotigadde S, Ballal M, Jyothiratha, Kumar A, Srinivas R, Shivananda PG. Mycotic keratitis: a study in coastal Karnataka. *Indian J Ophthalmol* 1992;40:31-33.
- [21] Hagan M, Wright E, Newman M, Doblin P, Johnson G. Causes of suppurative keratitis in Ghana. *Br J Ophthalmol* 1995;79:1024-28.
- [22] Jeng BH, McLeod SD. Microbial Keratitis (Editorial). *Br J Ophthalmol* 2003;87:805-06.
- [23] Dutta LC, Dutta D, Mohanty P, Sharma J. Study of fungal keratitis. *Indian J Ophthalmol* 1981;29:407-09.
- [24] Despande SD, Koppikar GV. A study of mycotic keratitis in Mumbai. *Indian J Pathol Microbiol* 1999;42:81-87.
- [25] Garg P, Gopinathan U, Choudhary K, Rao GN. Keratomycosis: clinical and microbiological experimece with dematiaceous fungus. *Ophthalmology* 2000;107:574-80.
- [26] Sunbaram BM, Badrinath S, Subramanian S. Studies on mycotic keratitis. *Mycoses* 1989;32:190-97.
- [27] Venugopal PL, Venugopal TL, Gomathi A, Ramkrishna ES, Ilavarasi S. Mycotic keratitis in Madras. *Indian J Pathol Microbiol* 1989;32:190-97.
- [28] Dunlop AA, Wright ED, Howlader SA, Nazrul I, Hussain R, McCellan K, et al. Suppurative corneal ulceration in Bangladesh: A study of 142 cases examining the microbial diagnosis, clinical and epidemiological features of bacterial and fungal keratitis. *Aust NZ Ophthalmol* 1994;22:105-10.
- [29] Liesegang TJ, Forstor RK. Spectrum of microbial keratitis in south Florida. *Am J Ophthalmol* 1980;90:38-47.
- [30] Panda A, Sharma N, Das G, Kumar N, Satpathy G. Mycotic keratitis in children: epidemiological and microbiologic evaluation. *Cornea* 1997;16:295-99.
- [31] Thomas PA. Mycotic keratitis – an underestimated mycosis. *J Med Vet Mycol* 1994;32:235-36.
- [32] Mino de Kasper H, Zoulek G, Paredes ME, Alborn R, Medina D, Denturian de Morinigo M, et al. Mycotic keratitis in Paraguay. *Mycoses* 1991;34:251-54.
- [33] Gugnani HC, Talwar RS, Njoku-Obi AN, Kodilinye HC. Mycotic keratitis in Nigeria. A study of 21 cases. *Br J Ophthalmol* 1976;60:607-13.
- [34] Mselle J> Fungal keratitis as an indicator of HIV infection in Africa. *Trop Doct* 1999;29:133-35.
- [35] Houang E, Lam D, Fan D, Seal D. Microbial keratitis in Hong Kong: relationship with climate, environment, and contact lens-disinfection. *Trans R Soc Trop Med Hyg* 2001;95:361-67.
- [36] Wong TY, Fong KS, Tan DTH. Clinical and microbiological spectrum of fungal keratitis in Singapore: a 5 –year retrospective study. *Int Ophthalmol* 1997;21:127-30.

#### AUTHORS

**First Author** – Dr Laltanpuia Chhangte, Postgraduate student, 3rd year, Department of Ophthalmology; GMC, Haldwani  
**Second Author** – Dr Shanti Pandey, Associate Professor, Department of Ophthalmology GMC, Haldwani  
**Third Author** – Dr Umesh, Professor, HOD, Department of Microbiology, GMC Haldwani



# Future Wireless Technology

Sneha Dixit

Jaypee Institute Of Information & Technology, Noida, India

**Abstract-** The development of wireless technologies in recent years started an era of highly-efficient information society. It is expected that the wireless technologies will become wider and deeper in the coming years. Understanding the greater importance of wireless communication in the future for both academics and industries around the world have initiated the study of the next generation, namely 5G, of wireless communication systems. The 5G technology ( fifth generation) also know as 2021 wireless network technology is the foremost phase of wireless communication standards ahead of current 4G/IMT standard. The coming 5G technology and Information & Communication technology (ICT) networks signify evolution of the globally connected digital society. The main contribution of this paper is definition of 5G i.e. Fifth Generation mobile network concept which is seen as user-centric concept instead of operator-centric as we have in 3G or service-centric concept as seen for 4G. In the proposed concept the mobile user is on the top of all.

**Index Terms-** Flat IP Network, BDMA, 5G Architecture- Nanotechnology, Cloud Computing.

## I. INTRODUCTION

The world has seen and exponential growth in the telecommunication industry in last few years. We have different types of mobiles keypad to Smartphone there has been a great development in wireless field from 1G to 2/2.5G and 3G to 5G. These generations can be differentiated from each other on the following aspects,

Radio access, data rates, bandwidth and switching schemes.

The developed world is already utilizing 4G and it is beyond imagination that what will be engulfed in 5G as everything is already embedded such as smallest mobile phones, speed dialling, largest memory, audio and video player, Microsoft office, etc. Pico net and Bluetooth technology has made data sharing a child's play.

The 5G technology ( fifth generation) also know as 2020 wireless network technology is the foremost phase of wireless communication standards ahead of current 4G/IMT standard. The coming 5G technology and Information & Communication technology (ICT) networks signify evolution of the globally connected digital society. The main contribution of this paper is definition of 5G i.e. Fifth Generation mobile network concept which is seen as user-centric concept instead of operator-centric as we have in 3G or service-centric concept as seen for 4G

## II. 5G NETWORK

The 5G wireless communication system will be a converged system with multiple radio access technologies integrated together. It can support a wide range of applications and services to comprehensively satisfy the requirements of the information society by the year 2020 and beyond.

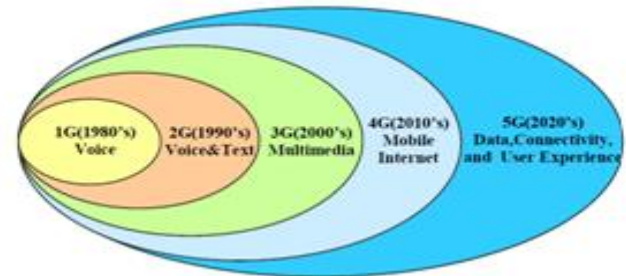


Fig.1 Development from 1G to 5G

5G networks use the flat IP concept to make it easy for different RAN to upgrade into a single Nano Core network. 5G uses Nanotechnology as a defensive tool for security concern that arises due to the flat IP. Surely the Flat IP network is the key to make 5G acceptable for all kind of technologies. To meet customer demand for real-time data applications delivered over mobile broadband networks, wireless operators are turning to flat IP network architectures. Flat IP architecture provides a way to identify devices using symbolic names, unlike the hierarchical architecture such as that used in "normal" IP addresses. The key benefits of flat IP architectures are

- lower costs
- reduced system latency
- decoupled radio access and core network evolution

This is of more interest to mobile broadband network operator's .With the shift to flat IP architectures, mobile operators can:

- Reduce the number of network elements in the data path to lower operations costs and capital expenditure.
- Partially decouple the cost of delivering service from the volume of data transmitted to align infrastructure capabilities with emerging application requirements.
- Minimize system latency and enable applications with a lower tolerance for delay; upcoming latency enhancements on the radio link can also be fully realized.
- Evolve radio access and packet core networks independently of each other to a greater extent than in the past, creating greater flexibility in network planning and deployment.

- Develop a flexible core network that can serve as the basis for service innovation across both mobile and generic IP access networks
- Create a platform that will enable mobile broadband operators to be competitive, from a price/performance perspective, with wired network

Flat network architecture removes that voice-centric hierarchy from the network. Instead of overlaying a packet data core on the voice network, separate and much-simplified data architecture can be implemented that removes the multiple elements from the network chain.

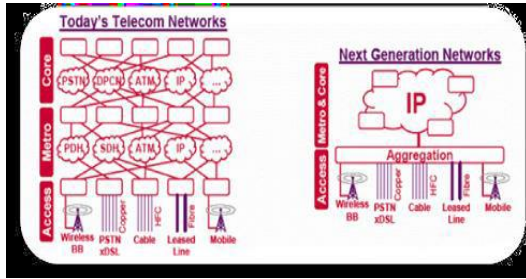


Fig.2 5G Network

The model that proposes design for a network architecture for 5G mobile systems, which is all-IP based model for wireless and mobile networks interoperability. The system consists of a user terminal (which has a crucial role in the new architecture) and a number of independent, autonomous radio access technologies. Within each of the terminals, each of the radio access technologies is seen as the IP link to the outside Internet world. However, there should be different radio interface for each Radio Access Technology (RAT) in the mobile terminal

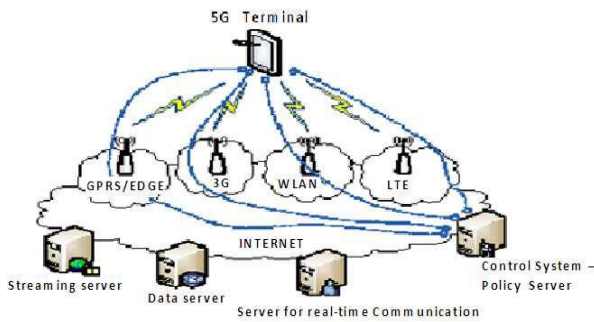


Fig.3 Design of 5G network

### III. 5G ARCHITECTURE

The 5G Nanocore is a convergence of below mentioned technologies. These technologies have their own impact on existing wireless network which makes them in to 5G.

- Nanotechnology.
- Cloud Computing.
- All IP Platform.

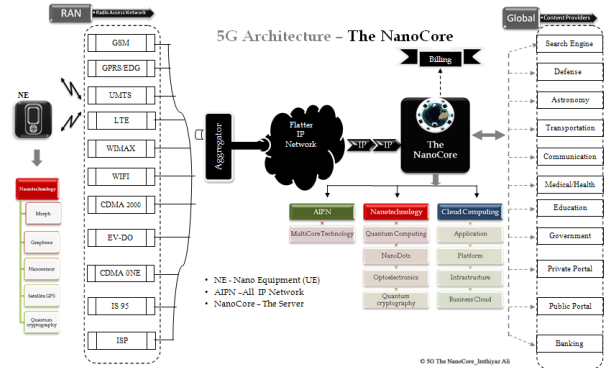


Fig.4 5G Architecture

### IV. NANOTECHNOLOGY

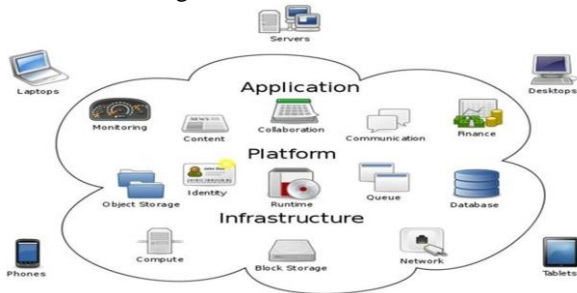
This is the application of nano science to make the control process to a nano meter scale which will be in between 0.1 and 100nm. This particular field is known as Molecular Nano Technology (MNT). Atom by atom and molecule by molecule based control of the structure of matter. The telecommunication industry will radically get changed into the latest Nanotechnology in little year time. Putting the impact in both mobile as well as core network is the mode of operation of the nanotechnology. Perfection in security and the better impact on the sensor makes the nanotechnology the most significant in its row. The most common and general identity of a human being nowadays is the mobile device. The nano equipment in the 5G nano core is the mobile phone itself as they are geared up with the nanotechnology. Wireless industry mainly aims at the implementation of the intelligence which will ensure that the computation and communication are available as desired. The introduction of intelligence in the mobile devices will help in embedding the devices in the human environments that can create a new platform which will enable the ubiquitous sensing, computing and communication. The nano equipments will be loaded with some of the core features like self cleaning, self powered, sensible to the environment with which it is been interacting, flexible and also transparent.

Cell phones enhanced with the carbon nanotube will be introduced soon which comes under the nanotechnology. In 5G Nanocore these mobile are referred as NanoEquipment as they are geared up with nanotechnology. One of the central visions of the wireless industry aims at ambient intelligence: computation and communication always available and ready to serve the user in an intelligent way. This requires that the devices are mobile. Mobile devices together with the intelligence that will be embedded in human environments – home, office, public places – will create a new platform that enables ubiquitous sensing, computing, and communication Specs of Nano Equipments given as follow:

- Self Cleaning – the phone cleans by itself
- Self powered – the phone derives its energy/power from the sun, water, or air.
- Sense the environment – the phone will tell you the weather, the amount of air pollution present, etc.
- Flexible – bend but not break
- Transparent – “see through” phones

### V. CLOUD COMPUTING

Technology used for maintaining data and applications that uses the internet and central remote server is known as Cloud Computing. In 5G, the central remote server will be the main provider of content. Clouding will introduce a layer in which the consumers can use the applications without installation and also personal files can be accessed with the use of internet access. In Nanocore the same concept will be used in which the user tries to access his private account from a global content provider in the form of cloud. 5G will add on the real time applications through the Nanocore clouding.



**Fig.5 Segment of cloud computing**

The Cloud computing has three segments as follows:

- Applications
- Platform
- Infrastructure

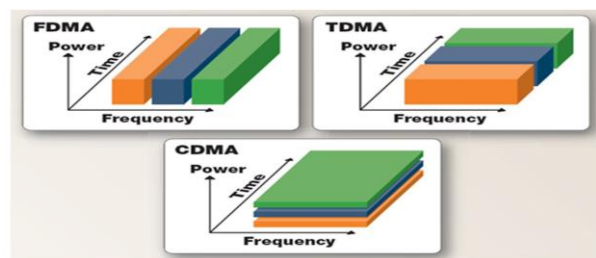
Applications means, software services on demand. The products which are used to deploy internet is generally referred to as the platform segment of cloud computing. The infrastructure and is the backbone of the entire concept. The infrastructure vendors will allow the user to build applications in this platform. Satisfying the customer demand is attained in 5G by the mutual integration of all the three segments. The CAPEX (Capital Expenditure) of 5g has been reduced by the cloud computing deployment.

### VI. ALL IP NETWORK

A common platform is required to interact for the convergence of different technologies to form a single 5G Nanocore. The essential part of the 5G network will be the Flat IP architecture. So as to meet the increasing requirement of the mobile telecommunication market, All IP Network (AIPN) has been introduced by the 3GPP system. Migrating into AIPN will meet the requirements of the customer for the real time data applications delivered over the mobile broadband networks. Provision of the complete edge performance in terms of both performance and costs is the primary focus of the enhanced packet switched technology. The touched benefits of the IP architectures are reduction of the system latency, improved user experience, globally seamless access, core network evolution, and decoupled radio access, cost effectiveness and much more. Placement of the stringent performance demands on IP based equipments and devices, which leads to the growing demand of the multicore technology. Strong demands have been seen in the

Next Generation Network (NGN) infrastructures both in wired and wireless layers.

Another important challenge in the telecommunication field is that the network should be in such a way that it should be flexible and improved to provide larger number of connections to multiple users without losing the quality within the limited frequency spectrum available with the increased system capacity. Communication made possible within limited spectrum and time is the biggest challenge to be tackled properly without any loop holes. Meeting this target is achieved by the implementation of multiple access techniques like OFDMA, FDMA, TDMA, CDMA, etc. OFDMA (Orthogonal Frequency Division Multiple Access) technique divides and allocates the available frequency resources to maximize the resource utility efficiency. In OFDMA, the multiuser capability is achieved by assigning each user a subset of OFDM (Orthogonal Frequency Division Multiplexing) subcarriers. OFDM is a digital transmission technique that uses a large number of carriers spaced apart at slightly different frequencies. In FDMA the corresponding frequency division and allocation will take place and in CDMA and TDMA, code and time division multiplexing will happen accordingly. FDMA (Frequency Division Multiple Access) is a technology by which the total bandwidth available to the system is divided into frequencies. Unlike FDMA, CDMA (Code Division Multiple Access) separates calls by code. Every bit of a conversation is been tagged with a specific and unique code. The system gets a call, it allocates a unique code to that particular conversation, and now the data is split into small parts and is tagged with the unique code given to the conversation of which they are part of. In TDMA (Time Division Multiple Access) the division of calls happens on time basis. The system first digitizes the calls, and then combines those conversations into a unified digital stream on a single radio channel. Now it divides each cellular channel into three time slots that means three calls get put on a single frequency and then, a time slot is assigned to each call during the conversation, a regular space in a digital stream.



**Fig. 6 FDMA, TDMA, CDMA**

The users transmit in rapid succession, one after the other, each using its own time slot. This allows multiple stations to share the same transmission medium (e.g. radio frequency channel) while using only a part of its channel capacity. In near future it is expected that the capacity required in a mobile communication network will keep on climbing as the number of mobile stations are increased and apparently the data required in respective mobile stations is increased.

## VII. BDMA (BEAM DIVISION MULTIPLE ACCESS)

BDMA is the latest allocation technique in which an orthogonal beam is allocated to each mobile station. In this technique, an antenna beam will get divided and allocated into the locations of the mobile stations to provide multiple accesses and thereby increasing the capacity of the system. Since mobile stations and the base stations are in Line of Sight state, they can transmit beams which directed to each other's position for proper communication, without making any kind of interference with cell edge mobile stations. When the mobile stations are positioned at different angles compared to the base station, the base station will transmit the beams in such a way that different angles will be covered and at the same time multiple mobile stations will be taken care. The working is like one mobile station does not use one beam exclusively, but the mobile stations positioned at similar angles will keep on sharing the one beam to communicate with the base station. Mobile stations that are sharing the same beam will divide the same frequency or time resources and will use the orthogonal

According to the mobile communication environment, a base station can change the direction, number and respective widths of the beams adaptively with the almost easiness. Three dimensional mode of division will happen in the case of beams and hence a spatial reuse of frequency or time resources can be maximized. The first slot of communication is the base station and the mobile station does not know each other's position. The mobile station will detect their positions and the moving speeds and will transmit the entire information to the base station. The second stage is taken care by the base station. The base station will calculate the direction along with the width of a downlink beam which is based on the position and moving speed information received from the mobile station. After the calculation part is over, the base station will transmit the downlink beam to the mobile station with all the calculations regarding the direction and width.

## VIII. CONCLUSION

While the future is becoming more difficult to predict with each passing year, we should expect an accelerating pace of technological change. 5G is not a term officially used for any particular specification or in any official document yet made public by telecommunication companies or standardization bodies such as 3GPP, WiMAX Forum, or ITU-R. We conclude that nanotechnology, Cloud computing, All IP are the next great technology wave. We hope that this Paper helps to promote stronger links between people working in different fields creating future concepts of mobile communication, Internet services, Cloud computing, All IP network, and Nanotechnologies. We conclude that it is a great time to invest in startups. Nowadays mobile users have much awareness of the cell phone (mobile) technology.

## ACKNOWLEDGEMENT

Author is thankful to Prof. R.C Jain, HOD, JIIT, NOIDA for his support and guidance.

## REFERENCES

- [1] Nanotechnology Applications to Telecommunications and Networking, by Daniel Minoli.
- [2] Abdullah Gani, Xichun Li, Lina Yang, Omar Zakaria, Nor Badrul Anuar, Multi-Bandwidth Data Path Design for 5G Wireless Mobile Internets, WSEAS Transactions on Information Science and Applications archive, Volume 6, Issue 2, February 2009. ISSN: 1790-0832.
- [3] Toni Janevski, 5G Mobile Phone Concept, Consumer Communications and Networking Conference, 2009 6th IEEE [1-4244-2308-2].
- [4] Nanotechnologies for Future Mobile Devices by TAPANI RYHA" NEN Nokia Research Center, Cambridge, 2007

## AUTHORS

**First Author** – Sneha Dixit completed her B.Tech from S.C.R.I.E.T, Meerut (2006-2010) in Electronics & Instrumentation branch and M.Tech from J.I.I.T, Noida (2012-2014) in Electronics & communication



# Film Bulk Acoustic Wave (FBAR) Resonator

Sneha Dixit

Jaypee Institute Of Information & Technology, Noida, U.P, India

**Abstract-** In recent years, there has been an exponential growth in wireless communication systems. This is basically due to the manufacture of small size and high performance devices. Many communication devices such as filter, duplexer and oscillator require resonator as a key component. Acoustic resonators have become a key technology of growing wireless field as the propagation velocity of acoustic wave is almost five times lower than the electromagnetic waves thus resulting in small size devices. BAW resonator can be used as narrow band filter in radio-frequency applications.

**Index Terms-** BAW Resonator, BVD, Parameter of Interest

## I. INTRODUCTION

The growing use of mobile communication systems that operate at radio frequencies (RF) of call for ever smaller, better and cheaper bandpass filters. These bandpass filters are required to transmit or receive signals within a certain bandwidth at a specified frequency and suppress all other signals. Global positioning systems (GPS, Galileo), mobile telecommunication systems (GSM, PCS, UMTS), data transfer (Bluetooth, Wireless Local Area Network WLAN), satellite broadcasting and future traffic control communication are examples of such applications. Bandpass filters for RF signal treatment are today fabricated using different technologies:

i) ceramic filters based on dielectric resonators, ii) filters using Surface Acoustic Wave (SAW) resonators, and iii) filters using thin film Bulk Acoustic Wave (BAW) resonators.

The Bulk Acoustic Wave (BAW) resonators and filters operating in the GHz range are used in mobile phone for the filtering purpose. BAW resonators can be used as narrow band filters in RF/Microwave applications. Their advantages are small size, monolithic implementation allowing large scale integration of MMIC devices, high mechanical quality (Q) performance, and large power handling capabilities, series and parallel resonance usable for bandpass filters, compatible with standard IC technology and low cost.

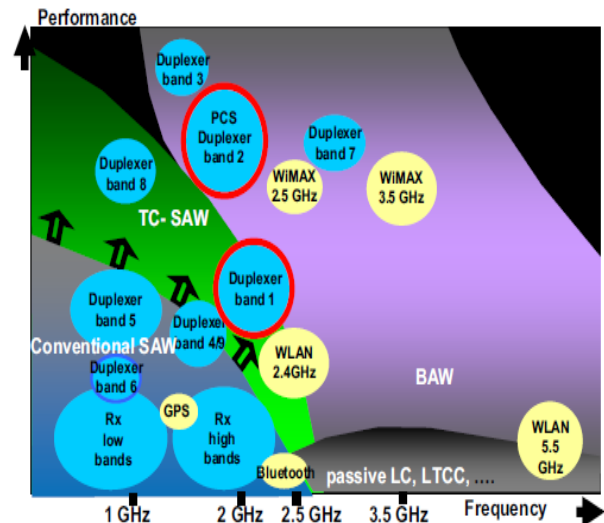


Fig.1: Mobile commercial applications mapped to current RF filter technologies, performance and frequencies

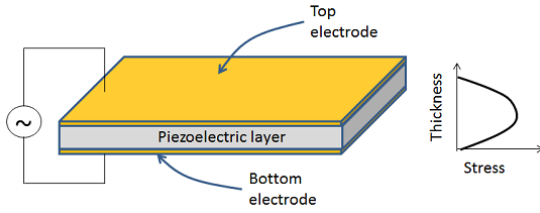
## II. BAW RESONATOR

BAW device has acoustic wave propagation (acoustic wave that propagates through the substrate) in the piezoelectric material between the top and the bottom electrode. It is a piezoelectric device, means that the piezoelectric effect brings the electromechanical conversion.

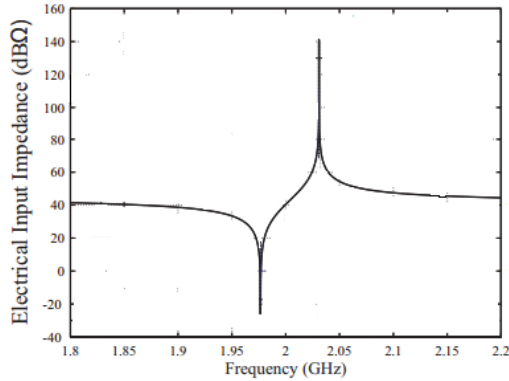
The BAW resonator is the core element of the BAW technology. The basic Baw resonator is composed of a piezoelectric plate sandwiched between metallic electrodes and having reflecting boundaries to confine the acoustic wave. In simple way to understand we can take it like this that the resonator is in the form of a simple capacitor. When an alternating electric potential is applied to a piezoelectric material, it produces mechanical deformation. The FBAR act as an acoustic cavity resonator in which the acoustic wave bouncing back and forward between walls  $\lambda/2$  apart upon proper excitation. The electrodes (Al, Au etc.) act as acoustic impedance discontinuities and the medium filling the cavity is a piezoelectric material (ZnO, AlN etc.). The electrical impedance response of FBAR has two resonant frequencies i.e. series resonant frequency where impedance is minimum and parallel resonant frequency where impedance is maximum

The main mode of operation of BAW resonator is the thickness or longitudinal mode, meaning that the bulk acoustic wave reflects the large plate surface and the resonance caused by the wave excited to the thickness direction.





**Fig.2 Excitation of BAW Resonator**

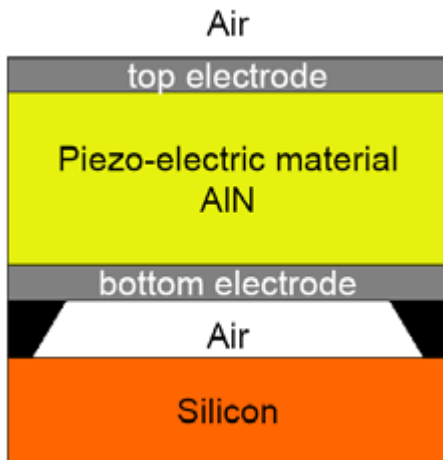


**Fig.3 Ideal electrical input impedance**

The performance of a film bulk acoustic wave resonator (FBAR) is analysed by the impedance characteristics of the resonator. The impedance of a resonator is characteristics of the resonator. The impedance of a resonator is characterized by two resonances: first at the resonance frequency ( $f_r$ ) where the magnitude of the impedance tends to its minimum value and the second at anti – resonance frequency ( $f_a$ ) where the magnitude of the impedance is maximum. The fundamental resonance frequency  $F$  of the thickness excited FBAR is given by:

$$F = \frac{v}{\lambda} = \frac{v}{2t}$$

Where,  $v$  is the velocity of fundamental thickness,  $\lambda$  is the acoustic wavelength and  $\lambda = 2t$ ,  $t$  is the thickness of the device.



**Fig4 Schematic view of bulk acoustic wave resonator FBAR**

The relationship between acoustic impedance, acoustic velocity and thickness of electrode and piezoelectric material is given by:

$$z_e/z_p = \tan \theta_e \cdot \tan \theta_p$$

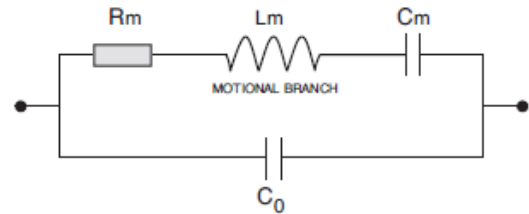
Where,  $z_e$  and  $z_p$  are the acoustic impedance of electrical and piezoelectric material. The FBAR has air interface at top and bottom electrode for acoustic isolation the air cavity is created by micromachining. The resonance frequency of the lateral mode is approximated by:

$$F = N (v_L/2w)$$

Where,  $N$  is the mode number,  $v_L$  is the velocity of the lateral mode,  $w$  is the distance between electrode edges

**III. BUTTERWORTH-VAN DYKE (BVD)**

The equivalent circuit model of the BAW resonator is the Butterworth-Van-Dyke (BVD) model. It has two parallel branches- namely, the motional and static capacitance arms. The motional arm comprises the series motional inductance  $L_m$ , capacitance  $C_m$ , and resistance  $R_m$ . The static branch is formed by the parallel- plate capacitance  $C_0$  formed between the top and bottom electrodes of FBAR



**Fig.5 Equivalent Circuit**

As the BVD explains the series and parallel resonance frequencies found in FBAR MEMS resonator, given by:

$$f_s = \frac{1}{2\pi(\sqrt{L_m C_m})}$$

$$f_p = \frac{1}{2\pi \sqrt{L_m \cdot \frac{C_m \cdot C_0}{C_m + C_0}}}$$

**IV. PARAMETER OF INTEREST**

The two parameter of interest are as follows:

- Electromechanical Coupling Coefficient,  $K_{eff}^2$

It is a important parameter for the design of BAW filter because the width of the filter passband that can be achieved depends on it.

$$K_{eff}^2 = \frac{\pi f_r}{2 f_a} \cot \left( \frac{\pi f_s}{2 f_p} \right)$$

- Quality Factor

The Quality factor is a measure of the loss of a resonator circuit and is defined as the ratio of the stored energy divided by the power dissipated in that network over one cycle.

$$Q = f_r / \Delta f_{3dB}$$

Where,  $f_r$  the resonance frequency and the other one is the bandwidth

#### V. CONCLUSION

The FBAR are highly useful for the design of low cost, small size and high performance filter, duplexers and oscillators for wireless systems

#### ACKNOWLEDGEMENT

Author is thankful to Prof. R.C Jain, HOD, JIIT, NOIDA for his support and guidance.

#### REFERENCES

- [1] Mahon S, Aigner R. Bulk acoustic wave devices—why, how, and where they are going. In CS MANTECH conference, pp. 15-18, Austin, Texas, USA, 2007
- [2] CAMPANELLA ,H. Acoustic Wave and Electromechanical resonators: concept to key Applications .Norwood: Artech House, 2010
- [3] K. Y Hashimoto editor, RF Bulk Acoustic wave Filters for communications, Norwood: Artech House, 2009
- [4] K.M. Lakin, “Thin Film Resonators and Filters,” 1999 IEEE Ultrasonics Symposium Proc., pp.895-906.
- [5] J. Rosenbaum, Bulk Acoustic Wave Theory and Devices. Artech House, 1988.
- [6] M. Ylilammi, “Handbook of Bulk Acoustic Wave Resonators and Filters,” 2000, VTT Internal report.

#### AUTHORS

**First Author** – Sneha Dixit completed her B.Tech from S.C.R.I.E.T, Meerut (2006-2010) in Electronics & Instrumentation branch and M.Tech from J.I.I.T, Noida (2012-2014) in Electronics & communication

# Anti-Inflammatory Activity of Chrysin in Acute and Chronic Phases of Inflammation in Guinea Pigs

Warda Mohamed Kaidama and Rajesh N. Gacche

Department of Biotechnology, School of Life Sciences, S.R.T.M. University, Vishnupuri, Nanded, Maharashtra, India-431606.

**Abstract-** To evaluate the anti-inflammatory activity of flavonoid (Chrysin 40 mg/kg) on acute inflammation (carrageenan-induced paw edema) and chronic inflammation (cotton pellet granuloma) in guinea pigs. Group I (control) received 1ml of 5% carboxymethyl cellulose suspension, group II pigs were treated with indomethacin (10 mg/kg) and Chrysin at a dose of 40 mg/kg was given orally to group III. 1.0 ml of carrageenan was injected s.c. to plantar region of right hind paw of each pig. The change in paw volume was measured at 0, 1, 2, 3 and 4 hours intervals. For chronic model of inflammation, sterilized cotton pellets, weighing 50±1 mg each, were implanted into both sides of the groin region of each pig, under light anesthesia. Drug treatment was given for 7 days. On the eighth day, cotton pellets along with granuloma were removed surgically, and wet pellets were weighed, after that dried at 60 °C overnight and then the dry pellets weight was taken. The results indicates that, Chrysin at a dose of 40 mg/kg body weight exhibited significant inhibition ( $P<0.05$ ) in acute and chronic inflammation models, which was comparable with standard drug. Hence, we can conclude that, Chrysin have significant anti-inflammatory effects in both acute and chronic inflammatory conditions.

**Index Terms-** Anti-inflammatory activity, carrageenan, cotton pellet granuloma, Chrysin.

## I. INTRODUCTION

When pathogens or irritation occurs and damage cells, inflammation appears as a defensive agent by the tissue as a response to such above mentioned harmful factors [1]. Inflammation plays two major roles in specifying damage and enhancing treatment of tissues. Although inflammation is beneficial in providing defense against infection invaders, it may become unchecked in case of pathogenesis of chronic inflammatory disease [2]. The basic mechanism of inflammation is that the cells linked with inflammation on membrane to produce acid and several eicosanoids as well as the releasing of lysosomal enzyme. There are two sorts of inflammatory activities acute and chronic which are recognized to be unresolved activities formed by many various compounds of chemical factors such as prostaglandins, leukotriene's and palate motivating agent and so on like this. Anti-inflammatory factors intensify their impact through chain of various methods of action [3].

The response of acute inflammation is categorized by the rising of vascular permeability and cellular infiltration causing edema composition due to the extra vacation of fluids and

proteins accumulation of leukocytes at the inflammatory position for short time [4].

Chronic inflammation appears if the acute response is not enough to eradicate the agents of pro inflammatory and it compromises increasing of fibroblasts and infiltration of neutrophils with exudation of fluid. It rises by methods of growing increasing cells which can either spread or compose granuloma. Not only this but, it probably also happens because of the insistence of infection or antigen, recurring tissue injury, or a failure of endogenous anti-inflammatory mechanisms [5]. There are a lot of elements to an inflammatory reaction that can lead to the associated adverse and tissue damaging. The elements of inflammation play significant role in edema and granuloma composition as well as leukocyte infiltration [6]. Edema existence in the paw is because of a synergism between various inflammatory intermediates that raises vascular permeability and/or the mediators that increase flowing of blood. The level of acute inflammation is identified by carrageenan induced paw edema as it is widely used for such detection [7].

Flavonoids have significant function in maintaining human health and protecting it from any diseases. Furthermore it plays significant role in preventing and fighting allergy, viruses in addition to preventing of the properties of inflammation. This last one constitute an aspect employed for a long time in the Chinese traditional medicine and the cosmetic industry represented by the compound of plant extracts, but recently it has begun to be explored in depth, in order to identify the mechanisms responsible and the possibility for use of flavonoids as anti-inflammatory agents [8].

Flavonoids are referred to a component of normal substances take part in their chemical compounds various number of hydroxyl phenolic groups. They are existed in sources of vegetal origin (fruits, seeds, roots, flowers, tea or wine). Many different types of flavonoids which are identified and estimated to be no less than four thousands. Most of those varieties and almost all are phenyl benzopyrones of low molecular weight with a main structure composed by two benzene chains linked through a heterocyclic pyrane or pyrone. They form differences in their chemical structure that can simplify the interaction with specific receptor molecules and/or their respective pathways within the cells, such as apoptosis, cell activation to stress and cascades of protein signaling kinases. Based on molecular structure they are divided in four fundamental groups: flavones, flavanones, flavanoles and anthocyanin's [9].

Chrysin (5, 7-dihydroxy-2-phenyl-4 H-chromen-4-one) is a naturally occurring flavone chemically extracted from the blue passion flower (*Passiflora caerulea*). Chrysin is a flavone widely distributed in plants which was reported to have many biological

activities such as anti-oxidant, anti-microbial, anti-spasmodic, anxiolytic and anti-inflammatory activities<sup>[10]</sup>. Chrysin has been shown to induce an anti-inflammatory effect, most likely by inhibition of COX-2 expression and via IL-6 signaling<sup>[11]</sup>.

Treatment of inflammation is a long discussion as the conventional NSAIDs are well known to cause Adverse Drug Reactions. Moreover there is undertaking study to promote safer and more effective drugs for the therapy of inflammation. In view of this and on account of assumed worthlessness of this compound in the traditional treatment. Hence the current investigation was done to assess the anti-inflammatory process of Chrysin in experimental animal sample.

## II. MATERIAL AND METHODS

### Chemicals

Flavonoids (Chrysin), Carrageenan, Indomethacin were purchased from Sigma\_Aldrich Co. (St Louis, MO, USA). Polysorbate 80 USP (Tween 80) as a suspending agent for Indomethacin, Carboxy methylcellulose 5% as a suspending agent for flavonoid was purchased from Himedia Chemical Co. India.

### Animals

Healthy adult male guinea pigs weighing between (350 ± 650 g) were obtained from the animal house of Biology Department, Ibb University-Yemen and kept for 1 week on a commercial diet in environmentally controlled conditions (25 ± 5°C, 55 ± 5% humidity and 12h light–dark cycle) to acclimatize with free access to diet and water *ad libitum*. Animals were fasted overnight and weighed before the experiment. The study protocol was approved by Institutional Animal Ethics Committee.

## III. METHODOLOGY<sup>[12]</sup>

Animals were randomly divided into 3 groups of 6 pigs each; group I: Control (1ml of 5% carboxymethyl cellulose suspension); group II: Standard drug (indomethacin 10mg/kg); group III: Test drug (Chrysin 40mg/kg). All the doses were administered orally. The *in vivo* anti-inflammatory activity was studied using carrageenan induced paw edema.

### Carrageenan induced rat paw edema model<sup>[12]</sup>

0.1 ml of 1% Carrageenan was injected aseptically into the sub plantar surface of right hind paw of each pig. Paw edema was measured by mercury plethysmograph (VGO Basile, Italy) at '0' hour and at the end of '4' hours. The difference between the 0 and 4<sup>th</sup> hour reading gives the actual edema. Percentage inhibition (protection) against edema formation was taken as an index of acute anti-inflammatory activity. It was calculated by: Percentage inhibition of inflammation =  $[(V_c - V_t) / V_c] \times 100$   
Where:

V<sub>c</sub> = mean paw edema volume in the control group .

V<sub>t</sub> = mean paw edema volume in the drug-treated group.

### Cotton pellet-induced granuloma<sup>[12]</sup>

The cotton pellet induced granuloma in pigs was studied. The animals were divided into three groups of six animals in

each group. Cotton pellets weighing 50 ± 1 mg were autoclaved and implanted subcutaneously into both sides of the groin region of each pig. The first group served as control and received the vehicle only (carboxymethyl cellulose 5%). Second group of animals was administered with standard drug indomethacin (10 mg/kg). The animals of third group were treated with Chrysin (40mg/kg). All the doses were administered orally. On the 8<sup>th</sup> day, the animals were sacrificed and the pellets together with the granuloma tissues were carefully removed, dried in an oven at 60 °C weighed and compared with control.

### Statistical analysis

The effects of different drugs under study was presented by calculating the mean and SD of the outcome parameters. One way Analysis of Variance (ANOVA) and independent samples T test was applied to see the difference between any two groups at a time (5% significance level). SPSS for windows (version 15) was applied in the statistical analysis.

## IV. RESULTS AND DISCUSSION

### Anti-inflammatory studies

#### Carrageenan induced rat paw edema

The anti-inflammatory effect of the Chrysin using carrageenan induced edema tests is expressed in (Table I). In this test, the positive control (Indomethacin 10mg/kg) significantly (P<0.05) decreased the paw edema by 65%, 71%, 72% and 74% after 1, 2, 3 and 4 hours compared with non-treated control group value. Pigs with the Chrysin at 40 mg/kg/body weight significantly decreased (P<0.05) the carrageenan induced edema paw volume edema by 45%, 56%, 63% and 66 % after 1, 2, 3 and 4 hours respectively compared with non-treated control group values.

#### Cotton pellet induced granuloma in rats

The results of anti-inflammatory activity of Chrysin in cotton pellet induced granuloma is shown in (Table II). Chrysin (40mg/kg) group showed (31%, P < 0.05) decrease in granuloma formation as compared to control group, while standard indomethacin (10 mg/kg) group showed significant decrease in granuloma formation (37%, P < 0.05) (Graph III).

### Discussion

The anti-inflammatory process of flavonoids (Chrysin) was assessed employing acute (carrageenan-induced paw edema) and chronic (cotton pellet granuloma) models of inflammation. The current study discovered that Chrysin at a dose of 40 mg/kg have significant anti-inflammatory process in experimental animals.

Carrageenan-induced paw edema as *in vivo* model of inflammation was picked to evaluate the anti-inflammatory activity of natural products, especially in the acute phase of inflammation<sup>[13]</sup>. Carrageenan-induced inflammation is a biphasic phenomenon. The first phase, which occurs between 0 to 2.5 hours of injection of the phlogistic agent, has been attributed or serotonin. The second phase of inflammatory reaction which is measured at 3 hour is formed by the release of bradykinin, protease, prostaglandin and lysosome<sup>[14]</sup>. The results revealed that administration of Chrysin compound inhibited the edema starting from the first hour and during all phases of inflammation, which is perhaps inhibition of various phenomena

and chemical mediators of inflammation. The cotton pellet granuloma way has been largely employed to assess the increasing phase of chronic inflammatory reaction. The inflammatory granuloma is a typical feature of reaction. The events involved in this phase of inflammation are proliferation of macrophages, neutrophils and fibroblasts. The dry weight granuloma formed correlates with the amount of granulomatous tissue formed [15]. It can be inferred from (Table II), the Chrysin 40mg/kg significantly inhibited the granuloma tissue formation. This suggests the Chrysin have inhibitory effect on the proliferative phase of inflammation and probably may act by inhibition. This impact may be due to the cellular migration to injured sites and accumulation of collagen. Cell migration appears as a result of much different process including adhesion

and cell mobility. Flavonoids are naturally occurring compounds containing in vascular plants. Such compounds have been noticed to have anti-inflammatory features, both *in vitro* and *in vivo* [16]. A Several flavonoids have been found out to have significant anti-inflammatory activity [17]. This study emphasized that, the flavonoids in charge of its anti-inflammatory activity.

Non-steroidal anti-inflammatory drugs (NSAID) for instance indomethacin employed in this study are proved to inhibit cyclooxygenase enzymes I and II which are implicated in the production of inflammation mediating agent prostaglandin E2 (PGE2) from arachidonic acid [18]. Therefore, the pattern of anti-inflammatory activity exhibited by this extract was similar to that of indomethacin.

(Table I): Effect of Chrysin and Indomethacin on carrageenan induced edema paw volume in male guinea pigs.

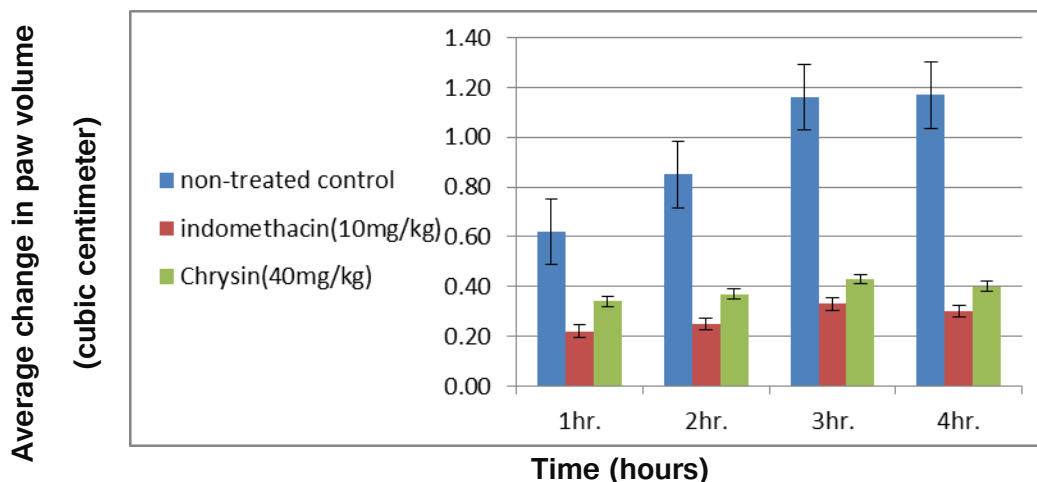
Groups	Mean paw edema(cm)± SD				%Percent inhibition at 4 hours
	1hr.	2hr.	3hr.	4hr.	
Non-treated control	0.62 ±0.009	0.85 ±0.005	1.16±0.005	1.17 ±0.01	0.0%
Indomethacin (10mg /kg)	0.22 ±0.009*	0.25 ±0.005*	0.33 ± 0.005*	0.30 ±0.01*	74%
Chrysin (40mg/ kg)	0.34 ±0.009*	0.37 ±0.005*	0.43 ±0.005*	0.40 ± 0.01*	66%

Values are expressed as mean ± SD, n=6 animals per group, \*p<0.05 as compared to control (one-way ANOVA).

(Table II): Anti-inflammatory activity of Chrysin and reference standard drug Indomethacin (10mg kg) on cotton pellet granuloma in normal male guinea pigs.

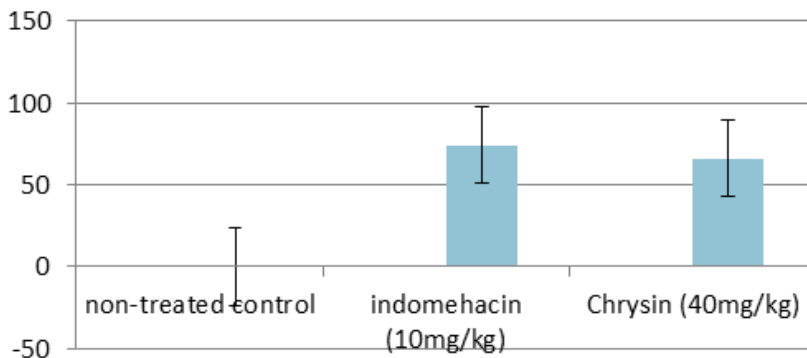
Treatment	Weight of dry granuloma (mg)	% of inhibition
Non-treated control	86.67 ± 5.41	0 %
Indomethacin (10mg/kg)	55.00 ± 1.95*	37 %
Chrysin ( 40 mg/kg)	60.00 ± 4.26*	31 %

Results are Mean ± SD (n=6) \*P<0.05 Compared to Control.

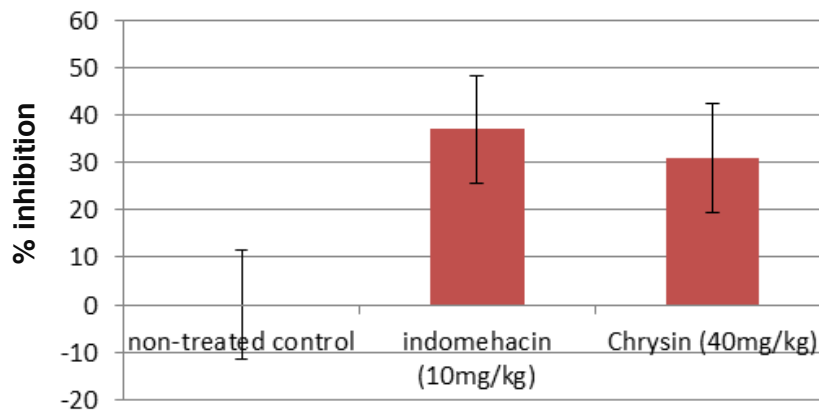


(Graph I): Effect of Chrysin and Indomethacin on carrageenan induced edema paw volume in male guinea pig.





(Graph II) : Percent inhibition (%) with the control, Standard (indomethacin) and the test compound (Chrysin), in the carrageenan induced paw edema.



(Graph III): Anti-inflammatory activity of Chrysin and reference standard drug Indomethacin (10mg/kg) on cotton pellet granuloma in normal male guinea pigs.

## V. CONCLUSION

In anti-inflammatory studies the Chrysin (40mg/kg) inhibited the carrageenan induced paw edema at both early and late phase. The action of early phase may be due to the inhibition of histamine and serotonin. The action of later phase may be due to the inhibition of prostaglandins, proteases and lysosome. From the results of acute inflammatory models, it can be concluded that the Chrysin (40mg/kg) showed good significantly ( $P < 0.05$ ) anti-inflammatory effects on carrageenan induced edema, which may be related to inhibition of inflammatory mediators formation.

In chronic cotton pellet induced granuloma model, Chrysin (40mg/kg) reduced ( $P < 0.05$ ) the granuloma formation. These studies have shown that the Flavonoids contain some active ingredients with the potential of being good anti-inflammatory agents. NSAIDs like indomethacin (10mg/kg), used as standard drug in anti-inflammatory study, is having good anti-inflammatory property.

## ACKNOWLEDGEMENTS

The author thanks to Dr. Ali Ahmed Hassan Al-baddany for his unlimited helps during the laboratory work.

## REFERENCES

- [1] Ferrero Miliani L, Nielsen OH, Andersen PS, Girardin SE. Chronic inflammation: importance of NOD2 and NALP3 in interleukin-1 $\beta$  generation. *Clin. Exp. Immunol* 2007; 147 (2): 227–35.
- [2] Hussain SAR, Juma'a KM, Ahmed ZA, Nuuman IT. *Af. J. Pharm. Pharmacol.* 2009; 3(5): 242-247.
- [3] Samuelsson B, Goldyne M, Granstrom E, Hamberg M, Hammarstrom S, Malmsten C. Prostaglandins and thromboxanes. *Annual Reviews of Biochemistry*. 1978; 47: 997-1029.
- [4] Posadas I, Bucci M, Roviezzo F, Rossi A, Parente L, Sautebin L, Cirino. Carrageenan induced mouse paw oedema is biphasic, age-weight dependent and displays differential nitric oxide cyclooxygenase-2 expression. *British Journal of Pharmacology*. 2004;142: 331-338.
- [5] Lundberg IE. The role of cytokines, chemokines, and adhesion molecules in the pathogenesis of idiopathic inflammatory myopathies. *Current Rheumatology Report*. 2000; 2: 216-224.
- [6] Mitchell RN, Cotran RS. In: Robinsons Basic Pathology, ed. 7. *Harcourt Pvt. Ltd., New Delhi, India*. 2000; 33-42.

- [7] Ialenti A, Ianaro A, Moncada S, Di Rosa M. Modulation of acute inflammation by endogenous nitric oxide. *Eur. J. Pharmacol.*1995; 211:177-184.
- [8] Nijveldt RJ, Van Nood E, Van Hoorn EC, Boelens PG, Van Norren K, Van Leeuwen, PAM: Flavonoids: a review of probable mechanisms of action and potential applications. *Am J Clin Nutr.*2001; 74:418-425.
- [9] Middleton E, Kandaswami C, Theoharides TC: The effects of plant flavonoids on mammalian cells: implications for inflammation, heart disease and cancer. *Pharmacol Rev.*2000; 52:673-751.
- [10] Dao TT, Chi Y S and Haeil Park. Synthesis and inhibitory activity against COX- 2-catalyzed prostaglandin production of chrysin derivatives. *Bioorg. Med. Chem. Lett.* 2004; 14: 1165-1167.
- [11] Bharucha PB, Naik HB. Synthesis and antibacterial activity of some chalcone and 1,4-oxazipine Derivatives. *Asian J. Chem.* 2000; 12: 318-320.
- [12] Vogel HG. Analgesic, anti-inflammatory and antipyretic activity. In: Vogel WH, Scholkens BA, Sandow J, Muller G, VogelWF (eds.), *Drug discovery & evaluation Pharmacological Assays*, 2nd edition, *New York, Springer.*2002; pp:759-767.
- [13] Yi YL, Zong HA, Zhen ML, Xong YX, Xiao MZ, Wen FD. Analgesic and anti-inflammatory effects of the dry matter of culture broth of *Termitomyces albuminosus* and its extracts. *Journal of Ethnopharmacology.* 2008; 120: 422-426.
- [14] Amberkar Mohanbabu V, Tara S, Meena Kumari K, Bairy KL, Smitha S. Evaluation of anti-inflammatory and analgesic activities of *Kaempferia galangal* in rats. *Indian Journal of Physiology and Pharmacology.* 2011; 55(1): 13-24.
- [15] Swingle KF, Shileman FE. Phases of inflammatory response to subcutaneous implantation of cotton pellet and their modification by certain anti-inflammatory agent. *Journal of Pharmacology and Experimental Therapeutics.* 1972; 183: 226-34.
- [16] Vasudevan M, Gunman KK and Parle M: Anti-nociceptive and anti-inflammatory effects of *The spesiapopulnea* bark extract. *J Ethnopharmacol.*2007; 109: 264-270.
- [17] Kim H, Son K, Chang H, Kang S. Effects of naturally occurring flavonoid on inflammatory response and their action mechanism. *Nat. Prod. Sci.* 2000; 6:170-178.
- [18] Moody JO, Robert VA, Connolly JD and Houghton PJ: Anti-inflammatory activities of the methanol extracts and an isolated furanoditerpene constituent of *Sphenocentrumjollyanum* Pierre (Menispermaceae). *J Ethnopharmacol.* 2006; 104: 87- 91.

#### AUTHORS

**First Author** – Warda Mohamed Kaidama , Department of Biotechnology, School of Life Sciences, S.R.T.M. University, Vishnupuri, Nanded, Maharashtra, India-431606., warda\_m\_2012@yahoo.com.

**Second Author** – Rajesh N. Gacche, Department of Biotechnology, School of Life Sciences, S.R.T.M. University, Vishnupuri, Nanded, Maharashtra, India-431606.

# FILTERING EFFECT IN HOLOGRAPHIC IMAGE PROCESSING

Ferdous Ahmed\*, Md. Sultan Mahmud\*\*

\*Electrical and mechanical Engineering Corps, Bangladesh Army, Bangladesh

\*\*Professor and Head of the Department of Basic Sciences and Humanities, University of Asia Pacific, Dhanmondi R/A, Dhaka-1209, Bangladesh

**Abstract**— The most popular application of holography is using the technique to make three-dimensional images. This paper describes an algorithm for computationally generating holograms along with methods to fabricate the hologram. The phrase, “digital holography”, is common place in the optics community; it describes the methods used to reconstruct holographic images from physically recorded holograms as well as the methods used to construct holograms from virtual objects using a computer. In fact we have the ability to create digital holograms from imaginary objects and then recreate the image of those objects using the same digital holograms, the entire process performed on a single computer. A computer simulation technique for generating Fourier holograms using the Fraunhofer diffraction formula is applied. These generated Fourier holograms were analyzed for experimental reconstruction. A detailed analysis was done on the computation and numerical reconstruction. Filtering technique was used to analyze its feasibility to be used in image processing. Corresponding reconstructions were verified by MATLAB for computer simulation. The algorithm of the MATLAB program is discussed. Using this technique, computer generated holograms can be of great use in image processing field.

**Index Terms**— Computer generated hologram, Digital holography, Filtering technique, Fourier holograms, Fraunhofer diffraction, Holography, MATLAB

## I. INTRODUCTION

The word holograph is derived from the Greek words ‘holos’ meaning whole, and ‘graphein’ meaning to write. A hologram, therefore, is something that records all of the information available in a beam of light, not just the amplitude, as in traditional photography, but also the phase of the light.

The wave theory of light is utilized in computer generated holography to represent both the object and reference waves mathematically. With this knowledge, the superposition of these waves at any point in space can be calculated to obtain the interference pattern required for the hologram. Computer generated holograms do not require actual objects to generate the hologram as long as the light scattered or diffracted off the object could be represented mathematically [2]. The light transmission and reflection properties of the object are no longer a problem since the ideal object wave can be computed mathematically, given its structure is properly described. Thus, a computer generated holographic image is computed by numerically simulating the physical phenomena of light diffraction and interference.

## II. Basic of Holography

A hologram is a recording of the optical interference pattern that forms at the intersection of two coherent optical beams [3]. Typically, light from a single laser is split into two paths, the signal path and the reference path. Figure-1 shows this holographic recording arrangement. The beam that propagates along the signal path carries information, whereas the reference is designed to be simple to reproduce. A common reference beam is a *plane wave*: a light beam that propagates without converging or diverging. The two paths are overlapped on the holographic medium and the interference pattern between the two beams is recorded.

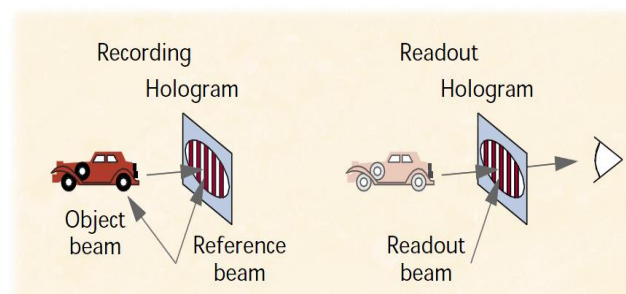


Figure 1: Hologram recording

and reading process

At the fundamental level, the difference between a hologram and a conventional photograph is that conventional photography records intensity of light while a hologram records both intensity and phase. Holography is done by recording the interference pattern

between coherent light and the incident light reflecting off an object.

### III. Fundamentals of Computer Generated Holography

D.

#### E. A. Optical Holography Vs Digital Holography

The optical holography technique demands the presence of the real object (for which the hologram is to be made). In optical holography recording, light from a coherent laser source scattered from the object is made to interfere with a reference light derived from the same source. The recorded fringe pattern when illuminated by the same reference light generates the object wave front (3D image). Nevertheless, in computer simulated holography, the entire recording and reconstruction processes are simulated using diffraction formula. The first computer generated hologram (CGH) was made by A.W.Lohmann and D.P. Paris in 1967. Thereafter this technique has undergone many improvements and changes in both procedure and computational techniques. Once the choice of the diffraction formula has been made, then the choice of suitable computer implementation procedures should be made. The computing environment should be chosen such that it improves speed, accuracy and also cost efficiency for that type of simulation method. In our work, the Fraunhofer diffraction formula is used for simulation. The holograms thus generated using diffraction formula can be used for optical reconstruction.

#### F. B. Computer Generated Hologram

Computer Generated Holography is an optical numerical technique, which avoid the traditional light interference recording process by computer numerical calculation and record the hologram directly [4]. It does not require the actual light and the actual existence of the recording medium and reduces the difficulty of the realization of holography. Computer Generated Holograms has many applications in digital storage and display systems. Numerical generation and encryption of hologram are two important topics that have instigated abundant research and analysis works within the past twenty years. An important need for synthesizing computer generated holograms is to create optical wavefronts from objects that do not physically exist. The process of synthesizing a hologram usually consists of the following steps. The first step is to compute the propagation of the complex amplitude from the object to the hologram plane. The second step is to encode the complex amplitude as a real, nonnegative function from which the hologram can be generated on a graphic output device. The simulation of the interference fringes caused by interaction between the reference beam and object beam in conventional holography can be considered as an example for this. The next steps are to make the hologram and to reduce it to a reasonable size for diffracting light. The final photo reduction step could be eliminated by using special output devices such that hologram can be written directly in the desired size. An important property of hologram is that information about the object is spread over the entire image plane; therefore each and every portion of hologram contains the complete information of the object. This property can be utilized so as to make holograms effective for communication.

G.

#### H. C. Computer Generated Hologram Vs Fourier Transform

According to scalar diffraction theory, the emanating wavefronts are spherical. The scalar diffraction theory at the end of Fresnel approximation reshapes the spherical wavefronts to parabolic wavefronts. Since the parabolic approximation is valid only for small diffraction angles this approximation is also called as paraxial approximation. The far field approximation of Fresnel diffraction formula yields the Fraunhofer diffraction formula [4]. The Fraunhofer diffraction formula is the Fourier transform of the aperture distribution. This formula greatly simplifies the calculations compared to Huygen – Fresnel diffraction formula. The simulation is employed using a simple algorithm in MATLAB language. The Fresnel diffraction formula is given by

$$U(x, y) = \frac{e^{jkz} e^{j\frac{k}{2z}(x^2+y^2)}}{j\lambda z} \int_{-\infty}^{+\infty} \int_{-\infty}^{+\infty} \left\{ T(\xi, \eta) \exp \left[ j\frac{k}{2z}(\xi^2 + \eta^2) \right] \right\} \exp \left[ -j\frac{2\pi}{\lambda z}(x\xi + y\eta) \right] d\xi d\eta$$

### IV. Experimental

In signal processing, particularly digital image processing, filtering has got significant effect on image quality [5]. A holographic image doesn't give out any meaningful image visually. But reconstructed image from the holographic image doesn't appear exactly as the original image. Rather it is reconstructed along with some other spurious frequencies due to inherent properties of digital image processing. These unwanted signals which cause reconstructed image differ from its original image, can be negated by suitably

applying filtering techniques namely Low Pass Filtering (LPF), High Pass Filtering (HPF) and Band Pass Filtering (BPF). The minimization is a criterion in filter design.

We know that Low Pass Filtering cuts off higher frequencies of certain level according to set parameter and High Pass Filtering cuts off lower frequencies of certain level. Filtering technique can be applied to a reconstructed holographic image if the image demands enhancing for its further use. Filtering technique can be applied to a holographic image through different image processing algorithms [6]. For our experiment, we used MATLAB program as our Computer Generated Hologram (CGH) is based on the same program. Depending on image class, processing algorithm and programming level, the applied filtering effect can vary from unnoticeable to annoying. Aggressive image filtering can also result to distortion in reconstructed image. Such as, the drawback of a low-pass filter is a ringing effect that occurs along the edges of the filtered spatial domain image. Multiplication in the Fourier domain corresponds to a convolution in the spatial domain. Due to the multiple peaks of the ideal filter in the spatial domain, the filtered image produces ringing along intensity edges in the spatial domain. Fraunhofer diffraction yields the Airy disk as point spread function, which has a ringing pattern. On the other hand, high pass filtering may generate sharp edges near the color transition within an image.

#### I. A. Effect of Low Pass Filtering on Holographic Image

```
a1=imread('image location.jpg');
%Provide image location%
a=rgb2gray(a1);
%size(a)
% size(a1)
af=fftshift(fft2(a));
%size(af)
figure, imshow(af);
fftshow(af)
[x,y]=meshgrid(-512:511,-512:511);
z=sqrt(x.^2+y.^2);

c=z<12;
%size(c)
af1=af.*c;
fftshow(af1)
af11=ifft2(af1);
ifftshow(af11)

c=z<64;
af1=af.*c;
fftshow(af1)
af11=ifft2(af1);
ifftshow(af11)
```

#### J. B. Effect of Image Enhancing Technique on Holographic Image

```
a=imread('image location.jpg');
%Provide image location%
a1=rgb2gray(a);
af=fftshift(fft2(a1));
figure, imshow(af);
fftshow(af)

[x,y]=meshgrid(-512:511,-512:511);
z=sqrt(x.^2+y.^2);

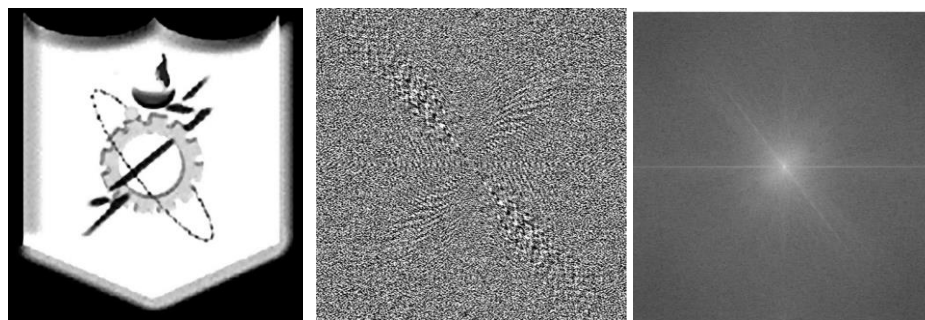
c=z>15;
%size(a)
hp=af.*c;
fftshow(hp)
hp1=ifft2(hp);
```



```
ifftshow(hp1)  
c=z>2;  
hp=af.*c;  
fftshow(hp)  
hp1=ifft2(hp);  
ifftshow(hp1)
```

### V. Results and Discussions

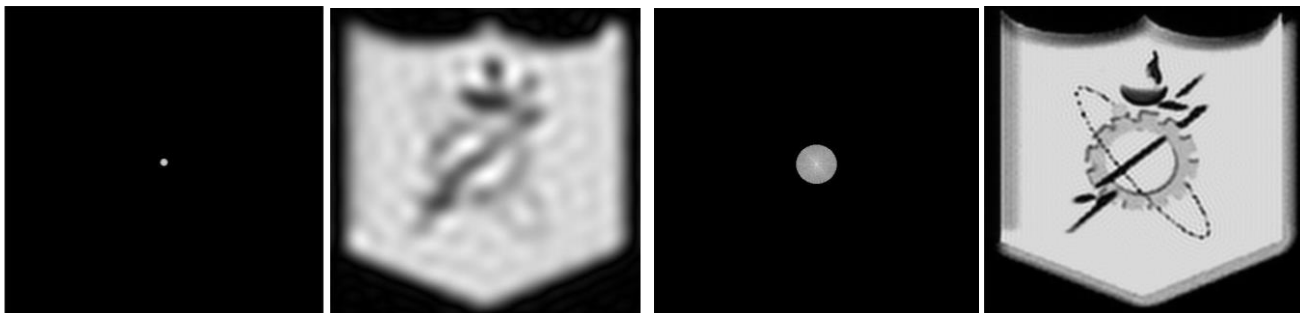
The quality of reconstructed image with respect to original image is visible from Figure - 2. Low pass filtering effect and high pass filtering effect on reconstructed image with different filtering level are shown in Figure - 2 and Figure - 3 respectively. The filtered images vary depending upon the filtering level applied on reconstructed holographic image which is evident from the properties discussed [7, 8].



(a) Original Image

(b) Hologram

(c) Hologram-FFT Show



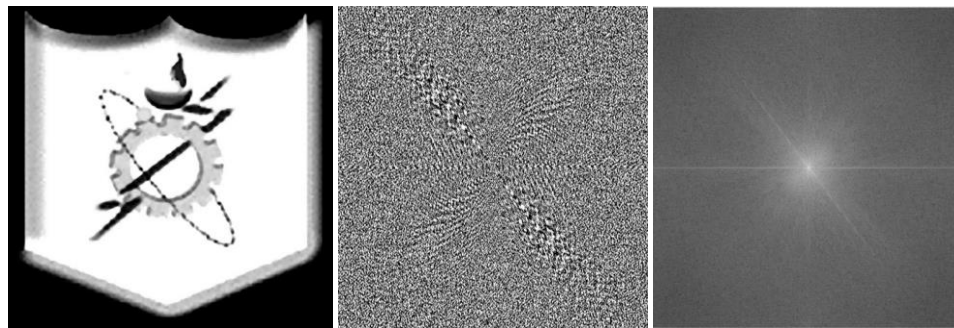
(d) LPF-Z<12

(e) Filtered Image

(f) LPF-Z<64

(g) Filtered Image

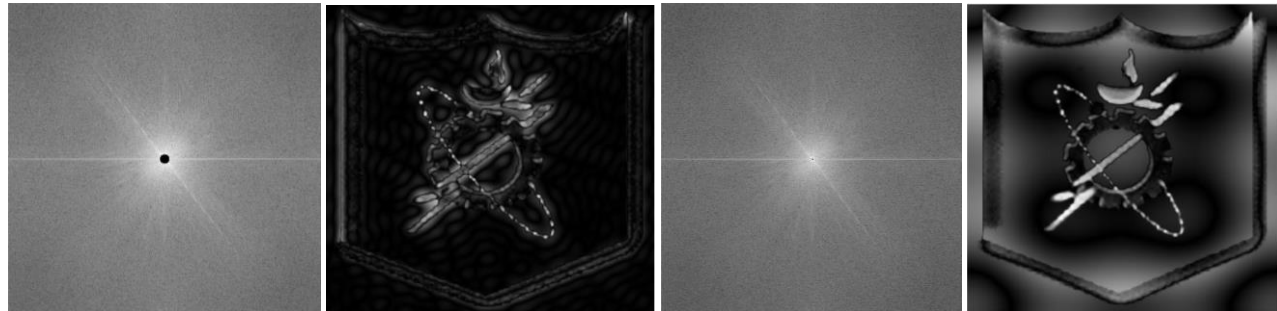
Figure 2: Low Pass Filtering Effect



(a) Original Image

(b) Hologram

(c) Hologram-FFT Show



(d) HPF-Z<15

(e) Filtered Image

(f) HPF-Z<2

(g) Filtered Image

Figure 3: High Pass Filtering Effect

It is observed from the above result that reconstructed image from its hologram when low pass filtered, gives out blurring effect and sharp edges are minimized. Again, reconstructed image from its hologram when high pass filtered, gives out reverse color effect.

## VI. Conclusion

This paper discusses the basic principles of hologram and implementation of computer generated holograms along with filtering effect on generated hologram. A simple algorithm for simulation of computer generated holograms was presented. Fourier transform operation was utilized to obtain the hologram of the object. The reconstruction of object image from the computer generated hologram was done. The image reconstructed from hologram after applying filtering effect contains portrays different response to the filtering parameter technique applied. A method to observe the output image by suitably modifying the hologram was discussed in the paper. An interesting property of hologram is that every portion of the hologram contains information about the object. The hologram was filtered at different levels and dimensions and overall filtered portions were reconstructed to get the object image. It was found that the reconstructed image depend on the position and size of filtering of the hologram.

## ACKNOWLEDGMENT

The author wishes to thank Jawaharlal Nehru Technological University for rendering support in doing research on Holographic Technology and grateful to Professor P. Syam Prashad for proper guidance.

## REFERENCES

- [1] Tung H. Jeong "Basic Principles and Applications of Holography", Lake Forest College, Lake Forest, Illinois; Fundamentals Of Photonics, Module 1.10, SPIE Digital Library
- [2] Computer Generated Holography, James B Wendt
- [3] J.W.Goodman, "Introduction to Fourier Optics", 2nd ed., The McGraw-Hill Companies, Inc., 1996
- [4] <sup>1</sup>Ferdous Ahmed and <sup>2</sup>Md. Sultan Mahmud "Fourier Optics and Computer Generated Hologram" (Submitted for publication in IJCSE)
- [5] Digital Signal Processing, by J.S.Chitode, Technical Publications, 2008, ISBN 978-81-8431-346-8, 4-70
- [6] A. Umnov, A. Nasonov, A. Krylov, Ding Yong. "Sparse method for ringing artifact detection" // In: Proceedings of International Conference on Signal Processing (ICSP2014). IEEE, Hangzhou, China, 2014, pp. 662-667.
- [7] <sup>1</sup>Ferdous Ahmed and <sup>2</sup>Md. Sultan Mahmud "Ringing Effect in Holographic Image Processing" (Submitted for publication in IJAMS)

- [8] Divya P.S.<sup>1</sup>, Sheeja M.K.<sup>2</sup> "A study and simulation of computer generated Hologram", International Journal of Advances in Engineering & Technology, July 2013. ©IJAET, ISSN: 22311963

#### AUTHORS

**First Author** - Ferdous Ahmed has completed Masters in Technology in Communication Engineering from Jawaharlal Nehru Technological University, India, PH-+8801769011945. E-mail: [rasselbd99@gmail.com](mailto:rasselbd99@gmail.com)

**Second Author** - Md. Sultan Mahmud has done PhD in Nano Technology from KUET, Bangladesh and Sweden. He is the head of the department of Basic Sciences and Humanities, University of Asia Pacific, Bangladesh, PH-+8801916974628. E-mail: head.bsh@uap-bd.edu

**Correspondence Author** - Ferdous Ahmed, Electrical and mechanical Engineering Corps, Bangladesh Army, Bangladesh, Cell: +8801769011945, E-mail: [rasselbd99@gmail.com](mailto:rasselbd99@gmail.com)

# EVA, ROCE, ROE, and EPS as Method of Assessment of Financial Performance and Its Effect on Shareholders' Wealth: Evidence From Bank Listed at Indonesian Stock Exchange in 2011 – 2013.

Hamidah

Department of Management, State University of Jakarta

**Abstract-** The study involved 30 Bank which go public, which is listed on the Indonesia Stock Exchange. This study used purposive sampling, using the data in the form of annual financial statements from 2011 to 2013. This study using the simple regression analysis method, namely by using the F test and t test, in order to determine the effect of the financial performance measurement results with the level of significance is  $(\alpha) = 0:05$ . All data were analyzed using SPSS and Eviews 7.0.

The results of this study partialy, shows that the calculation of EVA during the period 2011 to 2013 yielded positive results, although not significant in explaining the Shareholders' Wealth, it is proved that the EVA assessed can not predict the value-added. Measurement, ROCE and EPS, positive and significant impact on Shareholders' Wealth. While ROE negative effect on Shareholders' Wealth. Then, the results of the simultaneous study shows that there is a positive effect of the independent variables are represented by ROCE, ROE, EPS, and EVA on Shareholders' Wealth.

**Index Terms-** Financial Performance, Shareholder Wealth Maximization

## I. INTRODUCTION

In the midst of a slowing trend in the domestic economy and a weak exchange rate, Indonesian financial sector, especially the banking industry, remains solid. Banking risks are reflected in the credit risk, liquidity risk and market risk are also quite awake, with the support of capital is still strong resistance. Meanwhile, the growth of bank credit declined from 23.1% at the end of 2012 to 21.4% in December 2013 in line with Bank Indonesia's efforts to stimulate the economy moves toward a more healthy. However, none of these measurements can explain how much management can increase shareholders' wealth (Fogelberg and Griffith, 2000).

Performance measurement using traditional accounting ratios, such as Net Income (NI), Earning Per Share (EPS), Return on Equity (ROE) and Return on Assets (ROA). *Bank is the financial intermediary that offers the widest range of financial services – especially credit, savings, and payment services – and performs the widest range of financial functions of any business firm in economy*".

Fogelberg and Griffith (2000), "The advantage of EVA is that it is dollar-based and Tus, EVA correlates with wealth maximization maximization". This is supported by research conducted by Uyemura, Office, and Petit (1996) which states, "EVA has the strongest correlation with market value added". Performance appraisal using EVA approach led to the attention of management in accordance with the interests of shareholders. With EVA, the manager will think and act as well as shareholders (investors) ie investments that maximize returns and minimize capital cost levels so that the value of the company can be maximized.

EVA as sizing performance, not only has the advantage, but it also has its limitations. Here are some limitations of the method of Economic Value Added (EVA). Measurement of the performance of the EVA method, considered to be too simple. Some companies concluded that the EVA method does not match their company because in general the investment made by the company is long-term. Actual revenue or actual EVA of long-term investments can not be measured objectively because profits will be generated in the future can not be measured and estimated only subjectively. Determination of the period of time that one of the EVA method would be bad. The company will probably have a lot of new assets are not depreciated on the financial statements and it will show a negative EVA although the business will benefit in the long run.

The use of traditional financial ratios are still often used in different companies. It is proved that the EVA assessed can not predict the value added. In the circumstances explained above it is needed to evaluate the performance of banking . Basically, financial performance measurement is essential in order to provide information and an evaluation of materials for investors regarding the conditions and the financial position of the company. Need measurement of financial performance, which is able to provide proxy

information regarding the creation of added value for the shareholder. The measurements are typically used to assess the performance of a company that is ROCE, ROE, EPS, and EVA.

**Return on Capital Employed (ROCE)**, According Weetman (2003: 363), "ROCE is the ratio of the which measure the performance of a company as a whole in using all sources of long-term finance" Meanwhile, according Irala (2005), "ROCE is an improvement over the EPS as it links the returns generated to the capital. Given the company's goal is to increase profits, then the maximum ROCE indicates that the company has been able to improve efficiency in the use of funds and capital. ROCE ratio can be formulated as follows (Weetman, 2003: 363): the profit before interest and tax is used as the numerator in determining the company's operating results or return on capital employed. Profit before interest and tax is often referred to as EBIT (earnings before interest and tax). Denominator value obtained ROE (Return on Equity)

**ROE (Return on Equity)**. According to Ross, et al. (2010: 62), "ROE is a measure of how the stockholders fared during the year". Irala (2005), "ROE indicates how much the firm has earned on the funds employed by the shareholders". ROE is a ratio that shows the extent to which companies manage their own capital (net worth) to effectively and measure the profitability of the investments made by its own capital owners or shareholders of the company. (Van Horne and Wachowicz, 2011: 149). This indicates that the value of a high ROE will bring success for the company - which results in a high stock price and make the company can easily attract new funding. ROE is an important feature of a modern market economy as a whole and for each company (Walsh, 2003: 56). Basically, ROE as well as ROCE ratio, does not include the cost of capital in the calculation so that the shareholders who bear the entire risk of the company's business.

**EPS (Earnings Per Share)**. According Irala (2005), "EPS is a measurement of the company's per-share performance". Based on this definition, EPS is a performance measurement which assessed based on the value per share profit. Meanwhile, according Sawir (2001: 34), "EPS is a ratio used to determine how much net income per share". For that in its calculations, EPS does not include the cost of capital (debt) for the use of debt will lead to a change in earnings per share (EPS) and also changes in the risk - as these two factors will affect the company's stock price. Ratio Earning Per Share or EPS in question can be calculated and formulated as follows (Brigham and Houston, 2006: 25).

**Shareholders' Wealth**. Windsor (2008), "The shareholders' wealth can be defined, at any time, as the market capitalization of the public corporation". Meanwhile, according Bhasin (2013), describes the shareholders' wealth is "Creating wealth for the shareholders requires that the firm undertake investment decisions that have a positive net present value (NPV)".

The creation of shareholders' wealth maximum, means focusing on the motives and efforts to improve financial investors (Windsor, 2008). The same thing also expressed Bhasin (2013), the creation of wealth for the shareholders means associated with major changes that occur in periodic shareholder wealth. In general, these changes can be seen in changes in stock prices, dividends paid, and the capital increase during the period.

To measure the shareholders' wealth can be done in a way to know how much revenue that shareholders receive in an investment, through the existing stock price Stock Exchange stock. This can be evidenced by the distribution of dividends received by investors or other form of capital appreciation. Capital appreciation can be achieved if there is a change in the dominant value of the stock market (Raiyani and Joshi, 2011). To measure the shareholders' wealth (Windsor, 2008): In this calculation are taken into account is the amount of capital stock outstanding multiplied by the market price at the time calculated. The calculation itself is an estimate of the expected return on investment by the company. This estimate includes the expected dividend flows in the future

## II. DATA AND VARIABLES FOR THE STUDY

Determination Techniques Population and Sample, Criteria set out in the determination of the population and sample banks, namely:

1. Establish the studied banks are banks that have gone public, listed as the issuer since 2011-2013 continuously.
2. Issuing financial statements each year of observation.
3. Having a stock price data.

Based on the above criteria, elected 30 banks listed on the Stock Exchange (Stock Exchange Indonesia) with a study period of 2011 to 2013.

**Panel Data Regression Analysis**. Data panel is a combination of data from cross section and time series. Regressions using panel data referred to the panel data regression model. The advantages of using panel data regression, namely:

1. Able to provide more data resulting degree of freedom is greater.



2. Being able to overcome the problems that arise when there is a problem removal variables.

Panel data regression model is said to balance (balance panel) when the cross section of each unit having the same time series data. And vice versa, said unbalanced panel data when the observation time series of unit cross section is not the same. For this study, a panel data regression model used is a balanced panel data regression models. The approach used

Analysis Method, this study uses panel data regression. Data processing was performed by using a software that is Eviews 7.0. The software can be used to process the descriptive statistics, the classical assumption test, and panel data regression. Performed classical assumption of multicollinearity, heterocedastity and autocorrelation test model fit (Fixed / Random Effect), and hypothesis testing (Test F-statistics and statistical t-test).

Regression equation model can be seen as follows:

$$Y = \beta_0 + \beta_1ROCE + \beta_2ROE + \beta_3EPS + \beta_4EVA + e$$

Dimana :

$Y =$  , *shareholders' wealth*

$\beta$  = regression coefficient direction

$e$  = error,

In this study, the independent variables to be studied can be represented by:

$X_1 =$  ROCE

$X_2 =$  ROE

$X_3 =$  EPS

$X_4 =$  EVA

Testing needs to be done, namely:

1. Formulate operational hypothesis, namely  $H_0$  and  $H_a$

$H_0: \beta_1, \beta_2, \beta_3, \beta_4 = 0$ , there is no influence of ROCE, ROE, EPS, and EVA together against shareholders' wealth.

$H_a: \beta_1, \beta_2, \beta_3, \beta_4 \neq 0$ , there is the influence of ROCE, ROE, EPS, and EVA together against shareholders' wealth.

2. Determine the significance level ( $\alpha$ ) of = 5% or 0.05.

3. Perform calculations in accordance with the approach (tool) statistics are used is by using Eviews 7.0.

4. Take a conclusion on the analysis that has been done, the criteria are:

$H_0$  is rejected if sig.  $\beta < \alpha = 0.05$  and

$H_0$  is accepted if sig.  $\beta > \alpha = 0.05$

#### IV.RESULTS AND DISCUSSION

##### Descriptive Statistics

The main theme of the present study is to assess the performance of 30 Private Sector banks in Indonesia. The study intends to assess the financial performance of Private Sector banks and thereby identifying the influence of them in improving the share'holder wealth. The findings of through Table 1 revealed the following salient information:

**Table 1: Descriptive Statistics of Dependent and Independent Variables**

	SW	ROCE	ROE	EPS	EVA
Mean	3.03E+13	0.099842	0.132196	156.8492	-1.22E+09
Median	6.44E+12	0.095600	0.130450	90.50000	1551275.
Maximum	2.68E+14	0.262135	0.317165	865.2200	8.61E+10
Minimum	2.76E+11	-0.068000	-0.317870	-21.66000	-3.81E+11
Std. Dev.	5.89E+13	0.060350	0.089003	199.4308	4.26E+10

Source: the authors analyzed data using E-views 7.0

Shareholders' Wealth maximum worth owned by PT Bank Central Asia Tbk. is Rp 268 trillion. Proven in 2012, BCA stock price of Rp 7,600 per share, which means that the management of PT Bank Central Asia Tbk., Has been successful and is able to optimize its financial performance and its share price rose higher than the share price at other banks  
 Average ROCE is 10% larger than the standard deviation is equal to 6%. This indicates that the fluctuations and variability ROCE is low. Maximum ROCE amounted to 26.21% (2011) owned by PT Bank Central Asia Tbk which means that PT Bank Central Asia Tbk managed to make efficiencies in the use of funds and bank capital.

ROE can be seen that the mean value is 14% greater than the standard deviation is 7%. This indicates that the fluctuations and variability ROE is low. Maximum ROE was 31.7% (2011), owned by PT Bank Central Asia Tbk (BCA). Van Horne and Wachowicz (2011: 149), return on equity, or ROE high acceptance of the company often reflect on the strong investment opportunities and management cost effective. This indicates that the value of a high ROE will bring success for the company - which results in a high stock price and make the company can easily attract new funding.

The average value of EPS is \$ 157 which is smaller than the standard deviation of Rp 199. This indicates that the fluctuations and variability of annual EPS of high value. EPS is worth a maximum of Rp 865.22 (2013), owned by PT Bank Rakyat Indonesia, Tbk. In the EVA can be seen that the mean value is-Rp 1:22 Billion smaller than the standard deviation of Rp 42.6 billion. This indicates that the fluctuations and variability of the annual EVA high value. EVA is a maximum of Rp 86,060,541,392 (2012), owned by PT Bank Swadeshi, Tbk.

**Panel Data Regression Analysis**

Data panel is a combination of data from cross section and time series. Regressions using panel data referred to the panel data regression model. Researchers conducted tests of significance. Test the significance of each independent variable (X) is represented by variables ROCE, ROE, EPS, and EVA to the dependent variable (Y) is a Shareholders' Wealth. The three tests that have been carried out to obtain the results of tests of significance for each variable, namely:

**Tabel 2: Panel Data Regression Analysis Results**

Dependent Variable: SW  
 Method: Panel EGLS (Cross-section random effects)  
 Date: 07/02/14 Time: 18:35  
 Sample: 2011 2013  
 Periods included: 3  
 Cross-sections included: 30  
 Total panel (balanced) observations: 90  
 Swamy and Arora estimator of component variances

Variable	Coefficient	Std. Error	t-Statistic	Prob.
C	27.41657	0.580132	47.25915	0.0000
ROCE	7.992612	2.747799	2.908733	0.0046
ROE	-0.631910	1.255609	-0.503269	0.6161
EPS	0.254511	0.071705	3.549432	0.0006
EVA	0.011915	0.025603	0.465373	0.6429

Effects Specification		S.D.	Rho
Cross-section random		1.250628	0.8853
Idiosyncratic random		0.450141	0.1147

Weighted Statistics			
R-squared	0.193781	Mean dependent var	5.977063
Adjusted R-squared	0.155841	S.D. dependent var	0.537438
S.E. of regression	0.493788	Sum squared resid	20.72523
F-statistic	5.107592	Durbin-Watson stat	1.272570
Prob(F-statistic)	0.000977		

Unweighted Statistics	
-----------------------	--

R-squared	0.364847	Mean dependent var	29.37703
Sum squared resid	215.3486	Durbin-Watson stat	0.122473

7.0

Source: Data processed by the author using Eviews

### F-statistic Test Results

F test aims to measure whether the independent variable (X) simultaneously affect the dependent variable (Y) or to test the overall significance of regression coefficients, with the following criteria:

Ho is rejected if sig. F  $< \alpha = 0.05$  and

Ho is accepted if sig. F  $> \alpha = 0.05$

Based on Table 4.7., The value of the probability of 0.000977 with significance level of 5% or it can be said probability value less than 0.05, then Ho is rejected. This means that there is a positive influence ROCE (X1), ROE (X2), EPS (X3), and EVA (X4), simultaneously (together) to the shareholders' wealth.

### Results of t-test statistics

Based on the results of tests of significance are shown in Table 2, namely:

a. ROCE (X1), a positive effect on shareholders' wealth with regression coefficient of 7.992612 and has a probability value of t-statistic of 0.0046 so that Ho is rejected or it can be said there is a significant positive influence ROCE to shareholders' wealth. This ratio has a positive effect on shareholders' wealth, because according to the benefits generated by the ROCE which provides efficiency in the use of funds and capital in order to maximize shareholders' wealth (Weetman, 2003: 363)

b. ROE (X2), negative effect on shareholders' wealth with regression coefficient value of -0.631910 and t-statistic probability is equal to 0.6161, so that Ho is accepted or can be said to be having an adverse ROE shareholders' wealth, but not significant.

This is likely due to the high level of SBI in Indonesia, SBI rate in January 2011 starting at 6.5%. Then, an increase in February to September 2011 which became 6.75%. After that, the first-quarter decline is up in January 2012 by 6%. Then, jump down again during the last 15 months amounted to 5.75%, which was closed at the end of June 2013. Then, the month July 2013 increased by 6% and continues to experience a sharp increase gradually and finally in December 2013 amounted to 7.5%.

The increase in high-level SBI affect stock prices of banks. It thus can happen because the return on investment received by investors is low, so investors are not interested in doing an investment which causes the market price tends to go down. According Hamida (2011: 118), changes in interest rates are classified as market risk or the risk that can not be diversified. Then, Brigham and Houston (2006: 12) also explains the impact of the risk that if the high fixed costs, the decline in sales of the slightest, can lead to a sizeable decline in ROE.

c. EPS (X3), a positive effect on shareholders' wealth with regression coefficient of 0.254511 and has a probability value of t-statistic is equal to 0.0006 which is smaller than the significance level was set at 5%, so that Ho is rejected or it can be said there is a significant positive effect of EPS to shareholders' wealth.

This is possibly due to the measurement of EPS is often an important concern for the management and investors in financial analysis because often attributed as the main target in the bank's annual report which is to increase profits through increased sales performance of products and services of the bank. According Hamida (2011: 5), to maximize the stock price means also conduct business efficiently and maintain the quality of goods and services best. In addition, to maximize the stock price also means continuous innovation according to the needs and tastes of consumers are fickle. Innovation will lead to the creation of new jobs means also improving the welfare of society. This explanation is in accordance with the opinion expressed by Walsh (2003: 150), that the EPS growth also provide information on the development of a company.

d. Effect of EVA on Shareholders' Wealth

EVA (X4), positive effect on shareholders' wealth with regression coefficient of 0.011915 and probability value of t-statistic of 0.6429.  $H_0$  is accepted or can be said to exist EVA influence on shareholders' wealth but not significant, things that may lead to insignificant EVA test results to shareholders' wealth such as, the risk of the market, the increase rate of SBI which affect the magnitude of the cost of capital are borne by the bank. In addition, the use of traditional financial ratios are still often used in a variety of companies.

The same thing was stated by Hidayat (2006), there are several factors that led to the results of testing of EVA on shareholders' wealth is not significant that the popularity of EVA that has not been recognized by the market, the complexity of the calculation of EVA, plus hard earned some of the data for the calculation of EVA, and there is still controversy regarding the adjustment component in EVA.

The coefficient of determination ( $R^2$ )

To determine the coefficient of determination seen from the adjusted R-square ( $R^2$ ) are listed in Table 2 in this study amounted to 0.155841. Based on these results it can be concluded that 15% of the dependent variable can be explained by the variation of the four independent variables are ROCE, ROE, EPS, and EVA. While 85% is explained by other factors beyond the variables examined in this study.

## V. CONCLUSIONS

Based on the analysis that has been done before, then obtained the following results:

1. From the results of statistical tests were conducted to determine whether or not the partial effect of each independent variable on the shareholder's wealth, it was found that the ROCE and EPS significant positive effect on shareholders' wealth. While Eva significant negative effect on shareholder wealth. ROE is positive but not significant effect on shareholder wealth.

2. From the results of statistical tests were conducted to determine whether or not the influence of the independent variables simultaneously represented by ROCE, ROE, EPS, and EVA on shareholders' wealth of banks, it can be concluded that these variables have a positive influence. This one automatically reinforces the notion that the ROCE, ROE, EPS, and EVA together, can increase prosperity for its owners (shareholders' wealth).

## REFERENCES

- [1] Bhasin, M.L. 2013. "Economic Value Added and Shareholders' Wealth Creation: Evidence from a Developing Country". *International Journal of Finance and Accounting*. Volume 2 Issue 4. pp. 185-198.
- [2] Brigham, E. F. and Joel F. Houston. 2006. *Fundamentals of Financial Management*, Book 2, Issue 10. Singapore: McGraw-Hill.
- [3] De Wet, J. 2005. "EVA Versus Traditional Accounting Measure of Performance as Drivers of Shareholder Value - Mediatory Accounting Resarch". Volume 13. Issue No. 2, pp. 1-16.
- [4] Fogelberg, L. and John M. Griffith. 2000. "Control and Bank Performance". *Journal of Finance and Strategic Decisions* ". Volume 13. Issue No. 3. pp. 63-69.
- [5] Hamidah. 2011. *Financial Management*. Jakarta: Jayabaya University Press.
- [6] Hanafi, M. 2011. *Financial Management*. London: BPFE UGM.
- [7] Husnan, S. 2009. *Basics Portfolio Theory And Analysis Securities*. Yogyakarta: UPP STIM YKPN.
- [8] Irala, LR 2007. "Corporate Performance Measure in India: An Empirical Analysis". SSRN Working Paper Series WP-2007/01 / A. Retrived December. SSRN: ??? ssrn. com / abstract: 964 375.
- [9] Irala, LR 2005. "Economic Value Added: The Right Measure of Managerial Performance". *Indian Journal of Accounting and Finance*. Volume 19. Issue No. 2. April-Sept. pp. 31-43.
- [10] Kasmir. 2013. *Banks and Other Financial Institutions*. Depok: PT RajaGrafindo Persada.
- [11] Dates, S. and A. K. Sharma. 2011. "Association of EVA and Accounting Earnings with Market Value: Evidence from India. *Asia - Pacific Journal of Business Administration* ". Volume 3. Issue No. 2. pp. 83-96.
- [12] Nachrowi, D. and Hardius, U. 2006. *Popular and Practical Approach. Econometrics for Economic and Financial Analysis*. London: Institute for Publishers UI.
- [13] Patel, R. and M. Patel. 2012. "The Impact of EVA on Share Price". *International Journal of Contemporary Busines Studies*. Volume 3. Issue No. 2. pp. 24-34. Available online at <http://www.akpinsight.webs.com>.
- [14] Peter and Julianti. 2011. Assessment of Financial Performance of PT Bank Central Asia Tbk with EVA Method Using the Period of 2005-2009, As a Corporate [15] Performance Measurement Tool. *Scientific Journal of Accounting*. No. 5. Year 2nd. May to August. pp. 1-29.
- [16] Raiyani, J. R. and N. K. Joshi. 2011. "EVA-Based Performance Measurement A Case Study of the SBI, Bank HFDC". *Insight mangement*. Volume No. 7. Issue # 1. June. pp. 31-43.

- [17] Rakshit, D. 2006. "EVA-Based Performance Measurement: A Case Study of Dabur India Limited". Vidyasagar University Journal of Commerce. Volume 11. Issue No. 3. March. pp. 169-177.
- [18] Rose, Peter S. and Sylvia C.H. 2010. "Bank Management and Financial Services, Eight edition". Singapore: McGraw-Hill.
- [19] Ross, Stephen A., Randolph W. Westerfield, and Bradford D. Jordan. 2009. "Fundamentals of Corporate Finance". Singapore: McGraw-Hill International Edition.
- [20] Rousana, M. 1997. Utilizing EVA for Assessing the Company in Indonesia Capital Market. No. 4. Th. XXVI.
- [21] Sawir, Agnes. 2003. Investment Management. Jakarta: STIE IBII.
- [22] Sawir, Agnes. 2001. Analysis of Financial Performance and Corporate Financial Planning. Jakarta: PT Gramedia Pustaka Utama.
- [23] Sharma, A. K. and S. Kumar. 2010. "EVA: Literature Review and Relevant Issues". International Journal of Economic and Finance. Vol. 2 (1) .pp.200-220
- [24] Shil, Nikhil C. 2009. "Performance Measure: An Application of EVA". International Journal of Business and Management. Vol.4 (3). pp. 169-177.
- [25] Siva, D. and M. Kumaran Sarvankumar. 2011. "A Recent Analysis with Respect to EVA and Share Price Behaviour of Indian Banks European". Journal of Economics, Finance, and Administration Science. Issue No. 2. pp, 112-120.
- [26] Stewart, B. G. 1994. "EVA: Fact or Fantasy". Journal of Applied Corporate Finance. Volume 16. Issue No. 2-3. pp. 91-99.
- [27] Stewart, BG 1991. A Guide for Managers: The Quest for Value. USA: Harper Business.
- [28] Sugiyono. 2008. Business Research Methods. New York: Alfabeth.
- [29] Thenmozi, M. 2000. "EVA as a Measure of Corporate Performance". The Indian Journal of Commerce ". Volume 52. Issue No. 4. pp. 22-25.
- [30] Van Horne, J. and John M. Wachowicz, Jr. Principles of Financial Management, Book One, Ninth Edition. Heru Sutojo translation. Jakarta: Salemba Four, 1994
- [31] Wallace, JS 1997. "Adopting Residual Income - Based Compensation Plans: Do You Get What You Pay For?". The Journal of Contemporary Business Studies. Volume 24. pp. 275-300.
- [32] Walsh, C. 2003. "Key Management Ratios, Master of the Management Metrics that Drive and Control Your Business, Third Edition". New York: McGraw-Hill.
- [33] Weetman, P. 2003. "An Introduction Financial and Management Accounting, Third Edition". United Kingdom: Prentice Hall.
- [34] Widarjono, A. 2007. Econometrics: Theory and Applications. Yogyakarta: Ekonisia FE UII.
- [35] Windsor, D. 2008. Berle-Dodd debate. In Encyclopedia of Business Ethics and Society, ed. Robert W. Kolb. Vol. 1. 162-165. Thousand Oaks. CA: Sage Publications.
- [36] Worthington, A. C. and T. West. 2004. "The Australian Evidence Concerning The Information Content of EVA". Australian Journal of Management. Vol. 29 (2) pp. 201-224.
- [37] Young S., D. and Stephen F. O'Byrne. 2001. "EVA and Value-Based Management - A Practical Guide to Implementation". New York: McGraw-Hill.
- [38] <http://www.bi.go.id>
- [39] <http://www.finance.yahoo.com>
- [40] <http://www.idx.co.id>

#### AUTHORS

**First Author** – Hamidah, qualifications, Lecturer, Department of Management, Economic Faculty, Jakarta State University, Indonesia. email address.hamidahsam@gmail.com

**Second Author** – Sebastian, Student at Department of Management, Economic Faculty, Jakarta State University, Indonesia. Email : Sebastian@gmail.com



# BackTrack System: Security against Hacking

Munir A. Ghanem

Information Technology Department, Northern Border University

**Abstract-** Hacking became one of the world's most famous information technology problem. It's the work of whom doesn't has a work, a work to gain more money, a work to harm others, and a work for many other purposes. Almost every week, if it is not every day, we hear about hacking attacks that hits many significant sites in the country, such as: Ministries, Banks, Uniform sites and many other important persons accounts on the social network sites. Fortunately, not all the hackers are professional in hacking, but they trained them self on one or more of such programs for one of the previous purposes. On the other side, the secret of success in such hacking attacks is that the intended attacked targets did not take the proper precautionary measures to protect themselves from such attacks.

In this research, I am focusing on "BackTrack System" and highlight more on its security and protection capabilities that can be used to rise security precautions levels and analyze system network in order to determine weakness points and identify points that attack our system.

My research subject is very important, especially in these days, where we heard in almost every week, about an e-attack that hits major sites in my country; Saudi Arabia, while the majority of people frightened , doesn't know how to stop such attack.

**Index Terms-** BackTrack, Hacking, Security, tools.

## I. INTRODUCTION

Due to great developments that occurred in different technology fields and covers most of life aspects, depending on computer applications becomes an issue that no one can evade using it.

Computer applications exist in many important sites that can pose a threat to anyone, such as banks, passports general directorate, universities, ministries, emails web hosts, social media sites and many other sensitive country sites.

Depending on his interest, the hacker will be having so many options in which site to attack.

In the past few months, we heard about many e-attacks that hits many important electronic sites in Saudi Arabia. Unfortunately, these attacks happened without any reaction on how to stop such attacks, nor how to defend against it. The assumed hacker repeated his attack so many times, as he was confident that no one can stop him.

In this research, I am going to focus on the security tools of BackTrack system, which are really efficient and capable to analyze and protect from any hacking attack. This operating system "BackTrack" can launch a counter destructive attack.

**Lastly**, our research presentation in front of the discussion committee, will be followed by a practical application to show the security tools of BackTrack.

## II. PROBLEM DEFINITION

Problem that imposes to write this research can be summarized as follows:

1. Clear increase of hacking attacks without any deterrent or knowing how to stop it.
2. Unawareness of many individuals on how to secure their computers.
3. Raise people knowledge on e-piracy culture, and consequently raising knowledge of information security.
4. Active participating in national efforts against hackers attack.

## III. BACKTRACK SYSTEM

### 3.1. Definition:

It is an operating system based on Ubuntu GNU/Linux distribution aimed at digital forensics and penetration testing use. The most updated version of this operating system is "BackTrack 5", which called "Revolution"[1].

It is intended for all audiences from the most savvy security professionals to early newcomers in the information security field. It consists of many different programs and tools specialized in security, protection and hacking. BackTrack is famous with "Penetration test" that can identify network security weakness.

### 3.2. History:

BackTrack distribution originated from merging of two formerly competing distributions which focused on penetration testing[2]:

- **WHAX:** a Slax based Linux distribution that was developed by a security consultant, MatiAharoni; Earlier versions of WHAX were called *Whoppix* and based on Knoppix.
- **Auditor Security Collection:** a Live CD based on Knoppix that was developed by Max Moser, which includes over 300 tools organized in a user-friendly hierarchy.

### 3.3. Tools:

BackTrack system provide users with easy access to a comprehensive and large collection of security-related tools, ranging from port scanners to password crackers. BackTrack includes many well known security tools that can be summarized as follows:

- **Metasploit integration:** One of the major contents of Metasploit integration is the Metasploit project, which is used to analyze & test computer network by giving

information in regard to [security vulnerabilities](#), [penetration testing](#) and [IDS signature](#) development. Another one main content of Metasploit integration is the Metasploit Framework, which is used for developing and executing [exploit](#) code against a remote target machine. The Metasploit integration is well known for its [anti-forensic](#) and evasion tools, where some of it are built into the tool.

- Aircrack-ng: It is a network software suite consisting of a detector, [packet sniffer](#), [WEP](#) and [WPA/WPA2-PSK cracker and analysis](#) tool for [wireless LANs](#).
- Kismet : It is a [network detector](#), [packet sniffer](#), and [intrusion detection system](#) for [wireless LANs](#).
- Nmap: It's a network map-per that is used as a security [scanner](#) to discover [hosts](#) and [services](#) on the [computer network](#) by creating a "map" of the network. To achieve its goal, Nmap sends special crafted [packets](#) to the target host and analyzes the response.
- Ophcrack: It's a [free open source](#) program that [cracks](#) windows passwords by using [LM hashes](#) through [rainbow tables](#).
- Ettercap: It's a [free and open source network security](#) tool for [man-in-the-middle attacks](#) on [LAN](#). It can be used for computer [network protocol](#) analysis and [security auditing](#).

- Wireshark (formerly known as Ethereal) : It is a [free and open-source packet analyzer](#) that is used for [network](#) troubleshooting, analysis, software and [communications protocol](#) development.
- BeEF (Browser Exploitation Framework) : It is an [open-source penetration testing](#) tool used to test and exploit web application and browser-based vulnerabilities. BeEF provides the penetration tester with practical client side attack vectors. It leverages web application and browser vulnerabilities to assess the security of a target and carry out further intrusions. This project is developed for lawful research and penetration testing.
- Hydra: This tool is the best, fastest and most powerful tool to guess passwords that relies on any protocol.
- OWASP "Open Web Application Security Project": OWASP is an online community dedicated to [web application security](#).
- Cisco OCS Mass Scanner: It is a very reliable and fast scanner for Cisco routers with telnet/enable default password.
- Quyp (Terminal Emulator): It is a private software made by Crimson Hacking group. It is leaked to the Mainstream which is called Blackhat.

### 3.4: BackTrack System Releases [3]:

Date	Release
February 5, 2006	BackTrack v.1.0 Beta
May 26, 2006	The BackTrack project released its first non-beta version (1.0).
March 6, 2007	BackTrack 2 final released.
June 19, 2008	BackTrack 3 final released.
January 9, 2010	BackTrack 4 final release. (Now based on <a href="#">Debian</a> )
May 8, 2010	BackTrack 4 R1 release
August 18, 2011	BackTrack5 R1 release based on Ubuntu

### 3.5 Downloading & Using the System:

The system is available to be downloaded from the manufactured company official web site: <http://www.backtrack-linux.org/>. The user is recommended not to download the system directly to PC unless he is aware of this system properties, as his PC maybe exposed to risks of damaging all of his files, due to this system privacy. Therefore, it's recommended first to download a virtual program; VMware Workstation program and thereafter to download BackTrack.

Support for Live CD and Live USB functionality allows users to boot BackTrack directly from portable media without requiring installation, though permanent installation to hard disk.

Basically, for anyone who wants to download & use BackTrack, that the user has first to read intensively about the system to be familiar with its commands & tools.

### 3.5 Overview on BackTrack System:

This system has the same contents like any other windows operating system; e.g.: word editor, internet browser, control panel and many other user requirements & applications, in addition to the security tools which are the core of interest in this research.

BackTrack security tools can be arranged into twelve categories:

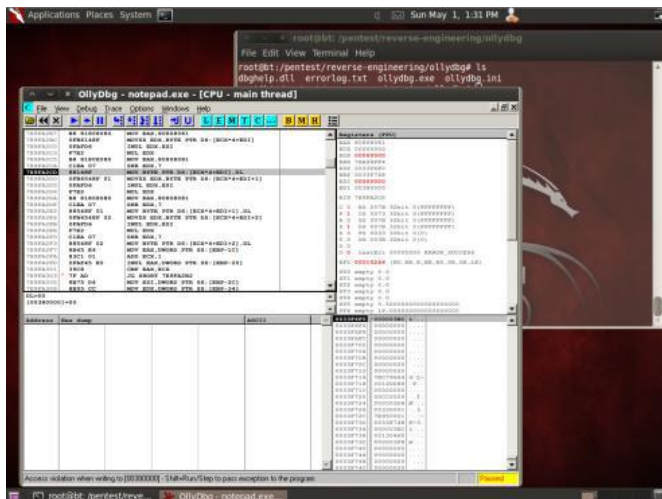
- Information Gathering.
- Vulnerability Assessment.
- Exploitation Tools.
- Privilege Escalation.
- Maintaining Access.
- Reverse Engineering.
- RFID Tools.
- Stress testing.

- Forensics.
- Reporting Tools.
- Services.
- Miscellaneous.

Generally, there are several tools in BackTrack, some of them to examine network by using network sniffers and file integrity checkers. Other tools are used to analyze and identify targets by using application security testing, vulnerability scanning, wireless scanning and network port/service identifiers. Some tools in BackTrack are used to find vulnerable targets with tools that crack passwords, test remote access and use penetration testing.

Additional tools that do not pertain to penetration testing that Backtrack also offers covers privilege escalation, maintaining access, reverse engineering, radio frequency identification (RFID) tools, stress testing, forensics, reporting tools, network services, and other miscellaneous tools. After all, Backtrack can stand out where it really can make a difference.

### 3.6 Photos of the program [1]:



### IV. CONCLUSION AND FURTHER WORK

1. This research raise an alert to the increase number of e-security breaches in my country; Saudi Arabia.
2. This research presents a system that is capable to permanently defend and stop e-security breaches
3. Through this research, I want to extend a recommendation to Saudi universities council to teach active information security courses during the bachelor's degree study plan, which synchronizes the modern developments that occurs in the hacking field.
4. Through this research, I want to extend a recommendation to Saudi universities to send excel students to participate in specialized information security training courses .

### REFERENCES

- [1] Retrieved from <http://realitynerd.wordpress.com/tutorials/operating-system-guide/linux/backtrack-5-cracking/>
- [2] Retrieved from <http://www.backtrack-linux.org/>
- [3] Retrieved from [http://www.cc.boun.edu.tr/network\\_security.html](http://www.cc.boun.edu.tr/network_security.html)
- [4] Retrieved from <http://www.greyfriars.net/gcg/greyweb.nsf/miam/article01>
- [5] W. Stallings, "Cryptography and Network Security-Principles and Practice", Fifth Edition, Pearson Education, 2010.
- [6] Retrieved from <http://forum.electroon.com/f39/>
- [7] Cardwell, Kevin. " BackTrack : Testing Wireless Network Security". Birmingham : Packt Publishing". 2013
- [8] Pritchett, Willie. "BackTrack 5 Cookbook". Birmingham, Packt Pub"2012
- [9] Ramachandran, Vivek. "BackTrack5 wireless penetration testing : beginner's guide". Birmingham

### AUTHORS

**First Author** – Munir A. Ghanem, Information Technology Department, Northern Border University, Email: [munir.ghanem@nbu.edu.sa](mailto:munir.ghanem@nbu.edu.sa).

# Civilization of the DACHL Countries Researching the Implementation of the D-A-CH-L Concept in Teaching German as a Foreign Language in R. Macedonia

Valentina Ilieva

PhD, Faculty of Education, Bitola, Macedonia

**Abstract-** Learners of the German language, irrespective of whether they learn the language in a German speaking country or in their native country, have one common goal – to be able to communicate in German in the German speaking countries as well as in the rest of the countries in the world. The German speaking countries do not include only Germany, but also some other European countries. What all these countries have in common is the usage of the German language, i.e. variants of the German language. Apart from the language which is the major precondition for successful communication, one should also consider the various civilization information of the German speaking countries, i.e. the D-A-CH-L countries (D for Germany (Deutschland), A for Austria, CH for Switzerland (Schweiz), and L for Liechtenstein). Hence, the inclusion of the D-A-CH-L concept in the process of teaching the German language as a foreign language presents itself as a necessity.

This paper analyses the application of the D-A-CH-L concept in teaching German in primary and secondary education in the Republic of Macedonia. Firstly, a survey has been conducted in randomly selected schools. Then, an analysis of the results is presented which is accompanied by comments and conclusions based on the research.

**Index Terms-** German as a foreign language, the German speaking countries, D-A-CH-L concept, D-A-CH-L countries

## I. INTRODUCTION

A civilization, in Lesli Bodi's terms, "in a world which has already become indivisible" should strive to enable understanding of the cultural differences of the social systems without reversing to ethno-inclusive linguistic nationalism and racism of the late 19<sup>th</sup> century and the dictatorships of the first half of the 20<sup>th</sup> century".<sup>36</sup>

Germany, Austria and Switzerland are all parts of the German speaking countries. What these three states share is their common interest to use the German language as a means for presenting their national identity and promoting international understanding.

The number of opportunities for cooperation, which could be initiated due to common interests, is indeed immense. These include, for instance, international support for the German language by organizing common scientific and cultural events. Moreover, the cooperation between the German speaking

countries also entails specific contribution to each of those countries.<sup>37</sup>

We agree with Krumm's contentions which include points which could easily be supplemented. The process of teaching German should not solely rely on the linguistic system as it should be made versatile and it should include information on: what distinguishes those who speak German from all the others; then, how those who speak German differentiate among themselves; the versatility of the language itself; the differences in the communicative modes of behavior as well as the differences in the conditions under which the German language and the communicative modes of behavior develop. In order to be able to understand this versatility, the sensibility for cultural differentiation and facts mediation, must be supplemented.<sup>38</sup>

Our inability to deal with versatility inevitably leads to discrimination, which implies that it is necessary to acquire an appropriate approach to versatility. The learning process could be successful merely when the subject and civilization tasks are correctly comprehended and carried out.

"The learner of the German language overcomes linguistic barriers, and civilization assists him in entering the German linguistic space, whereas the learners who study German in the German speaking countries have already put this concrete barrier behind them."<sup>39</sup>

According to the thesis number 8 of ABCD<sup>40</sup>, the civilization as an integral part of teaching German necessitates that the teachers of German as a foreign language implement data on all German speaking regions by bringing forth their own experience and presenting their students with varied material, and, thus, providing them with sound education.

Undeniably, the course book has a critical position in the teaching process for both students and teachers and its significance remains undisputed.<sup>41</sup>

There are visible attempts in the newer course books to incorporate civilization as "a broadened term"<sup>42</sup> by presenting information on geography, economics, politics, culture, history, education, literature, everyday life and society. In this context, both the motivation and location play crucial roles – the motivation in terms of why the learner studies the language, whereas the location in terms of whether the teaching process

<sup>37</sup> Rainer, 1992: 4-12

<sup>38</sup> Krumm, 1998: 523-544

<sup>39</sup> Krumm, 1998: 523-544

<sup>40</sup> Fremdsprache Deutsch 3/1990, S. 60

<sup>41</sup> Krumm, 1994: 23-29

<sup>42</sup> Krumm, 1994: 23

<sup>36</sup> Bodi, 1995: 33

occurs in a German speaking country or in some other foreign country. All these elements lead us to the assumption that the D-A-CH-L concept has been implemented in the process of teaching German.

In order to provide an overview of the process of teaching German as a foreign language in Macedonia, the table below depicts the school system and the process of teaching German according to the current syllabi. In accordance with the 2007 education reforms, the first foreign language taught is the English language and students start learning it in the first grade, whereas the second language is being introduced in the sixth grade.<sup>43</sup>

grade	1st foreign language/ no. of classes per week	2nd foreign language
9th	3	2
8th	3	2
7th	3	2
6th	3	2
5th	3	/
4th	3	/
3rd	3	/
2nd	2	/
1st	2	/

**Table 1**

In secondary schools and in high schools, German as a foreign language is an elective subject. Upon the introduction of the school reform, students study the two languages they studied in primary school, whereas in the new linguistic high schools they study 3 foreign languages (they continue studying the previous two foreign languages and they elect a third foreign language).

According to the statistic data, the German language as a foreign language is on the third position in the Republic of Macedonia. The webpage of the Bureau of Education<sup>44</sup> along with the national education program present a table depicting the number of students who studied German in the 2003/2004 school year. According to these statistic data, 14 856 students studied German as a second foreign language and 964 students studied it as a first foreign language in the secondary schools and high schools in the Republic of Macedonia.

### **Analysis of the opinion of teachers of German concerning the role and significance of teaching civilization**

In order to ascertain what students of German as a foreign language know about civilization and what teachers of German as a foreign language think about the role and the significance of teaching civilization, a study was carried out by conducting a questionnaire. The teachers' questionnaire was carried out in January, 2014.

#### a) The teachers' questionnaire

Sixteen teachers of German as a foreign language, two male and fourteen female teachers, responded to the questionnaire. In order to take preventative measures against receiving a small number of filled-in questionnaires which is one of the disadvantages of written surveys, the number of dispatched questionnaires was three times bigger than the number of questionnaires actually needed for this study. The questionnaire respected the respondents' privacy by requesting no personal data. In the teaching process in Macedonia the aim of this study was, in fact, twofold. On the one hand, it served the purpose of confirming our analysis based on theoretical grounds, i.e. it set out to either support the data and opinions formed on the theory or to relativize them. On the other hand, the second aim was to determine the significance attached to civilization in the teaching process by the respondents.

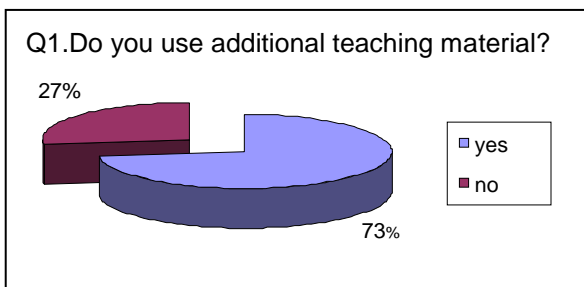
The introduction of educational and practical perspectives seems mandatory in the context of course books analysis by virtue of the fact that the interaction between teachers and students and students' interest are crucial factors in creating the teaching process.

<sup>43</sup>

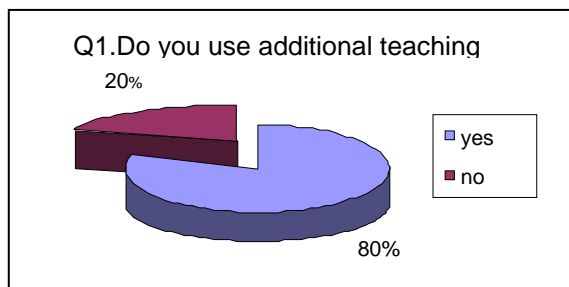
[http://www.bro.gov.mk/docs/nastavniplanovi/nastaven\\_plan\\_devetgodishno\\_2014-2015.pdf](http://www.bro.gov.mk/docs/nastavniplanovi/nastaven_plan_devetgodishno_2014-2015.pdf)



**The results of the analysis of the teachers' questionnaire**



**Chart 1** Primary school teachers



**Chart 2** Secondary school teachers

Eleven of the interviewed teachers teach German in primary schools, whereas five of them teach German in secondary schools. As it was expected, all of the teachers of German who teach in primary schools use the same course book which has been approved by the Bureau of Education at the Ministry of Education and Culture. The same was the case with the teachers of German in secondary schools and high schools as they also all use the course book approved by the Bureau of Education at the Ministry of Education and Culture. However, as it is presented on the graphs below, it is quite satisfactory that 73% of the interviewed teachers who teach German in primary schools and 80% of the teachers who teach German in secondary schools and high schools use additional teaching material.

- The civilization contributes to the culture of a particular country, whereas the language teaching process contributes to familiarize oneself with that culture. Civilization is an integral part of the language teaching process.
- Culture and civilization are of great help when it comes to achieving successful communication among nations.

**Question no.1**

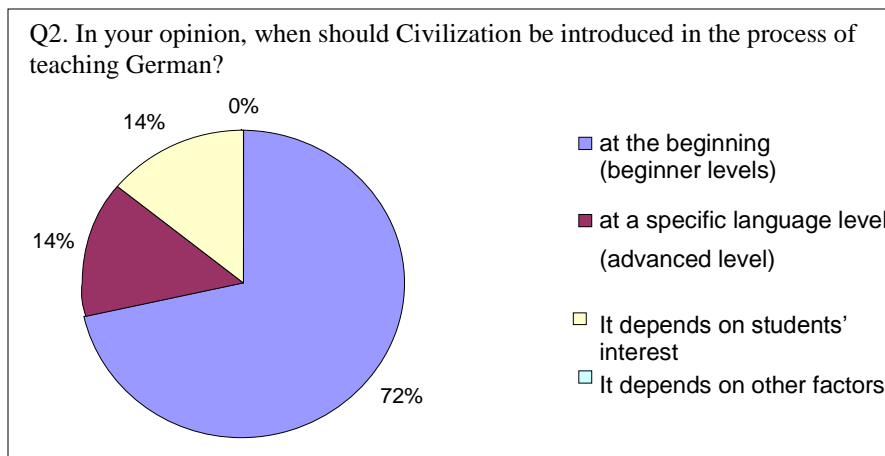
All interviewed teachers agree that teaching German is civilization, and civilization is teaching German. What follows is some of their statements pertaining to this issue:

- Culture and civilization are crucial in teaching a language.
- Every language teaching process is connected to the culture of the country, i.e. the culture of the people (e.g. lifestyle, food, typical expressions, mentality etc.).
- The culture is acquired via the language. The same is the case when one is interested in a particular culture – this person has to learn the language first.

**Question no. 2: In your opinion, what is the starting point when civilization should be introduced in the process of teaching German?**

The importance of incorporating civilization in the teaching process has been especially highlighted by the primary education teachers, which is a good precondition for incorporating civilization in the process of teaching German at the beginner levels.

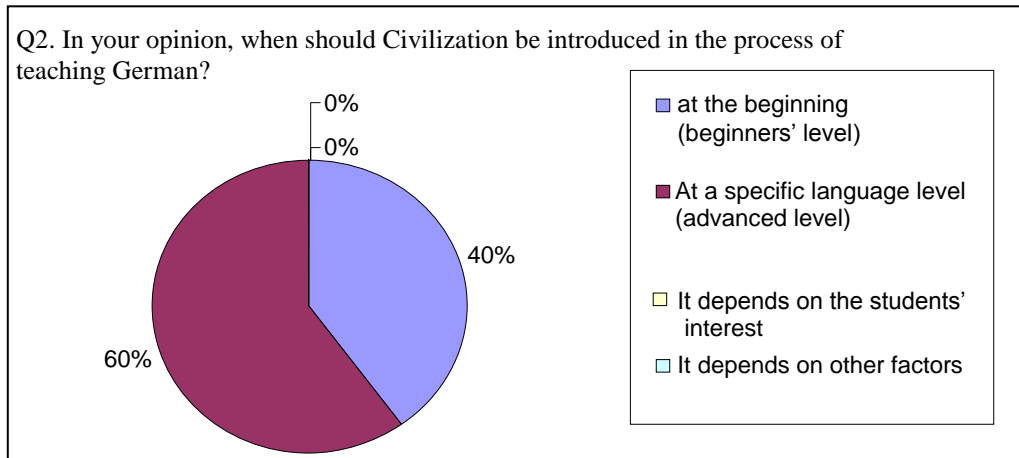
In fact, 14% of the interviewed teachers claim that civilization should be incorporated at a specific linguistic level or that civilization should be included depending on the students' interest. As to the question which examines whether the implementation of civilization is dependent on some other factors, none of the interviewed stated his/her opinion.



**Chart 3** Primary school teachers of German

Only one teacher did not provide an answer to this question. As far as this question is concerned the opinions of both sets of teachers (primary and secondary) differentiate substantially. Namely, 60% of the interviewed secondary and high school teachers feel that civilization should be included at a specific

linguistic level (advanced), whereas 40% believe that that should be done from the very beginning, i.e. at the beginners level. None of the interviewed teachers claims that this is conditioned by students' interest or some other factors.

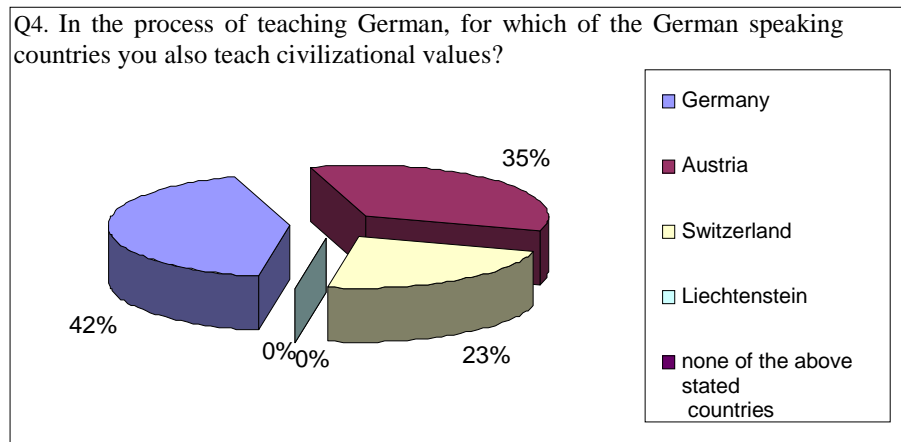


**Chart 4 Secondary and high school teachers of German**

**Question no.4 In the process of teaching German, for which of the German speaking countries you also teach civilizational values?**

This question presupposed several possible answers. Some of the interviewed primary school teachers of German marked in their answers civilizational values pertaining to Germany (42%), Austria (35%) and Switzerland (23%). Liechtenstein was not

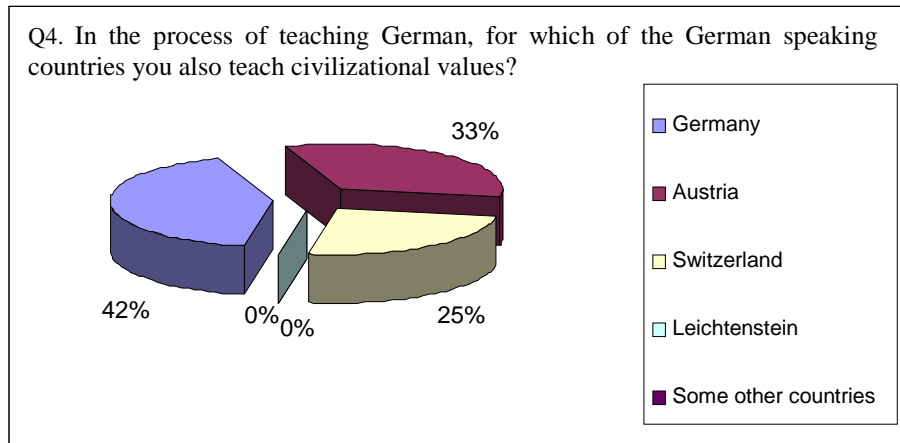
mentioned at all. This result demonstrates the intensity with which the civilization of these countries is being incorporated in the teaching process. Obviously, Germany is allocated the first position in that respect, Austria comes the second, followed by Switzerland, and, finally, Liechtenstein which is not included at all.



**Chart 5 Primary school teachers of German**

The interviewed teachers who teach German in secondary school and high school have also marked Germany (42%), Austria (33%) and Switzerland (25%). They did not mention

Liechtenstein (0%) at all. These results are indicative of the intensity with which they incorporate civilization in their teaching process.

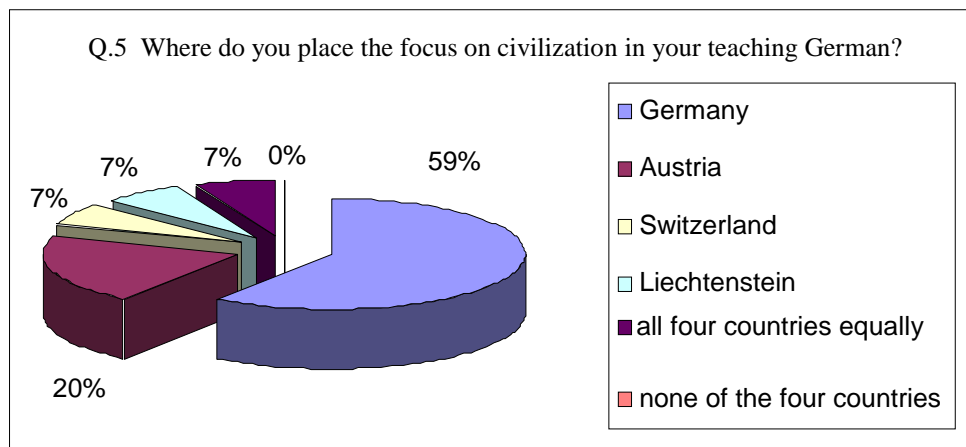


**Chart 6 Secondary and high school teachers of German**

**Question no. 5 Where do you place the focus on civilization in your teaching German?**

Primary school teachers' answers to this question also disclose that the primary position belongs to Germany (59%), then, Austria comes the second (20%), followed by Switzerland (7%) and Liechtenstein (7%). Only four teachers (7%) claim that

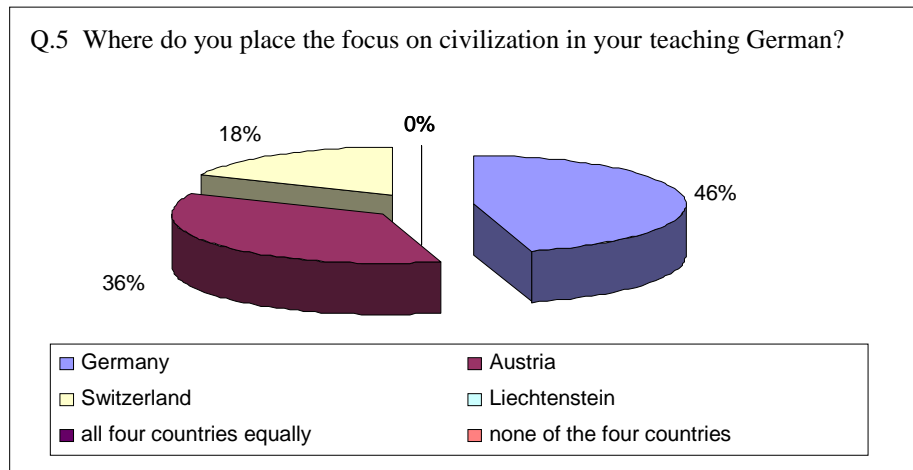
they place the focus equally to all four civilizations. These results obviously do not correspond with the implementation of the D-A-CH-L concept as the answers to this question, once more, emphasize the predominant position of Germany in comparison to the other three countries and their civilizations.



**Chart 7 Primary school teachers of German**

As to the same question, the interviewed secondary and high school teachers of German claim that again the main focus is put on Germany (46%), which is closely followed by Austria (36%). The third position belongs to Switzerland (18%) and, finally,

Liechtenstein was not mentioned at all (0%). None of the interviewed teachers chose the four countries. This result is not compatible with the implementation of the D-A-CH-L concept since these answers again put the stress on Germany's predominant position.



**Chart 8 Secondary and high school teachers of German**

The omission of civilization information about some of the German speaking countries could be spotted in most of the teachers' answers. Namely, the result is quiet satisfactory solely as far as the German civilization is concerned, and partly satisfactory in the case of the Austrian civilization. Hence, it can be concluded that these findings are not compatible with the ABCD theses and with the D-A-CH-L concept.

The question no.7 in the questionnaire directed the teachers to assess and state the extent to which their students were interested in the civilization of the German speaking countries, also provided them with the opportunity to choose among multiple possible answers. In that respect, the primary school teachers stated that 6 of their students were highly interested in Germany, 2 students were highly interested in Austria, 1 student was highly interested in Switzerland and none of them has shown any interest in Liechtenstein.

Furthermore, 5 students have shown moderate interest in Germany and Austria, 3 students demonstrated the same thing for Switzerland and 1 for Liechtenstein. A very modest interest has been shown by 2 students for Austria, 5 students for Switzerland and 4 for Liechtenstein. No interest has been shown by 4 students for Liechtenstein.

The same question was addressed to the secondary school teachers and high school teachers as well. They were also provided with the option to choose from multiple possible answers.

Their answers reveal that 4 of their students were highly interested in Germany. One student was moderately interested in Germany, 5 students were moderately interested in Austria, 1 student was moderately interested in Switzerland and no one was interested in Liechtenstein. A very modest interest in Switzerland has been shown by 3 students. Three students have shown no interest in Liechtenstein at all.

## II. RESUME

Some texts and contents which deal with, for instance, other cultures or historically distant periods of time, are virtually incomprehensible if there is lack of knowledge about the world we live in and its history, or if there is lack of geographical background, for instance. It is very important to not only reflect

on the reality relationship in the text itself, but also to take into consideration the relationship between the truthfulness presented in the text and the recipient's truthfulness. The science of comprehending a text and its interpretation in the international communication must be at the same time the science of relationships and obstacles which present themselves between nations/cultures/social groups/individuals which take part in them.<sup>45</sup>

This research shows that both primary and secondary school teachers share the opinion that civilization plays a crucial role in the process of teaching German. Moreover, their answers also reveal that civilization information which refers to the German speaking countries is rather scarce. Solely the German civilization displayed satisfactory and nearly satisfactory results in the primary school teachers and secondary school teachers' answers, respectively. The incidence of the Austrian civilization is partial and, consequently, is not compatible with the D-A-CH-L concept.

Moreover, students' enthusiasm to learn more on the German speaking countries is a positive indicator. However, one could infer that all of the German speaking countries do not receive an equal treatment in the process of teaching German. In other words, the good mental image of Germany, the poor mental image of Austria, and almost the non-existent mental image of Switzerland and the completely non-existent mental image of Liechtenstein in students' heads is not in compliance with the D-A-CH-L concept at all.

In the introductory part, we have already highlighted several factors and, consequently, an assumption, which indicate the importance of obligatory implementation of the D-A-CH-L concept in the process of teaching German. However, the result of this research refutes the assumption and one could conclude that the D-A-CH-L concept is not sufficiently respected in the process of teaching German.

Thus, the necessity for a quality improvement of the teaching process and materials presents itself quiet manifestly. The

<sup>45</sup> Picht, 1980: 270-288

contribution<sup>46</sup> to the solution to this problem could be made by observing the incidence of the D-A-CH-L concept in 4 areas:

1. the syllabi of the German language as a foreign language;
2. the course books and the additional teaching materials;
3. the classes of German;
4. the studies of German and the seminars for teachers' continuous professional development.

#### REFERENCES

- [1] Bodi, L. 1995: „Traditionen des österreichischen Deutsch im Schnittpunkt von Staatsräson und Sprachnation“, Österreichisches Deutsch, Wien Hölder, Pichler, Tempisky, Hg. R.Muhr u.a.
- [2] Fremdsprache Deutsch 3/1990, Zeitschrift für die Praxis des Deutschunterrichts, Goethe Institut
- [3] Ilieva, V. 2012: Das D-A-CH-L Konzept im Deutsch-als-Fremdsprache-Unterricht“, Universität Sv. Kliment Ohridski, FAMIS, Bitola
- [4] Krumm, H.J. 1994: Zur Situation der Lehrwerkkritik und Lehrwerkforschung Deutsch als Fremdsprache, Kast, B. / Neuner, G. (Hg.): Zur Analyse, Begutachtung und Entwicklung von Lehrwerken für den fremdsprachlichen Deutschunterricht. Berlin, München, Langenscheidt
- [5] Krumm, H.-J. 1998: Landeskunde Deutschland, D-A-CH oder Europa? Über den Umgang mit Verschiedenheit im DaF-Unterricht, INFO DaF 5/1998 und Plenarvortrag auf der 26. Jahrestagung des Fachverbandes Deutsch als Fremdsprache am 6.6.1998 in der Friedrich-Schiller Universität in Jena
- [6] Picht, R. 1980: Landeskunde und Textwissenschaft, Wierlacher, A.(Hrsg.) Fremdsprache Deutsch Bd.1 Finck München, Finck
- [7] Rainer, G. 1992: Deutsche Sprache und österreichische Auslandskultur, ÖdaF
- [8] [http://www.bro.gov.mk/docs/nastavniplanovi/nastaven\\_plan\\_devetgodishno\\_2014-2015.pdf](http://www.bro.gov.mk/docs/nastavniplanovi/nastaven_plan_devetgodishno_2014-2015.pdf)

#### AUTHORS

**First Author** – Valentina Ilieva PhD, Faculty of Education, Bitola, Macedonia

---

<sup>46</sup> Ilieva, 2012: 221



# Clinical and Endoscopic Study of Upper GI Manifestation in Corrosive Acid Ingestion

Dr. B. Sudarsi, M.D. \*, Dr. K.V.L. Sudha Rani, M.D. \*\*, Dr. R. Siddeswari, M.D. \*\*\*, Dr. S. Manohar, M.D.\*\*\*

\* Asst Prof. of Medicine, Department of Medicine, Osmania General Hospital, Hyderabad, Telangana State.

\*\* Asst Prof. of Medicine, Department of Medicine, Osmania General Hospital, Hyderabad, Telangana State.

\*\*\* Prof. of Medicine, Department of Medicine, Osmania General Hospital, Hyderabad, Telangana State.

\*\* FIAMS, Prof. & HOD of Medicine ; Department of Medicine, Osmania General Hospital, Hyderabad, Telangana State.

**Abstract-** The potentially catastrophic presentation and lifelong complications that result from corrosive ingestion make it one of the most challenging clinical situations. In this study we review clinical features and Endoscopic results of 50 patients admitted in Acute Medical Care of Osmania General Hospital with Corrosive Acid Ingestion. In our study commonest corrosive acid ingested was hydrochloric acid (n = 33) followed by phenyl (n=9), sulphuric acid (n=7) and nitric acid (n=1). The mean interval time of admission after ingestion of corrosive acid was 5.5 hrs.

The extent and severity of Upper Gastrointestinal injury was determined by fiber optic endoscopy within 48 hrs. All the patients had esophageal and gastric injuries. 27 patients had severe grade III injuries, 10 patients had grade II moderate injuries 10 patients had Grade I injuries and 3 patients had no injuries.

Complications and mortality occurred only in patients with grade III injury. Feeding jejunostomy was done in 6 patients of grade III injury with good results. FOB endoscopy is an accurate, safe and reliable method for assessing corrosive injury of Upper GI no complications were encountered during early endoscopy. Burns were graded according to modified Zargar et al classifications.

**Index Terms-** Endoscopic, Upper GI, Corrosive acid Ingestion

## I. INTRODUCTION

Caustic injury is usually produced by strong alkaline or acidic agents. Acid ingestion is common in India where hydrochloric acid and sulphuric acid are easily available as toilet cleaners<sup>1</sup>.

The Poison Prevention packaging Acts of 1970 and 1973, which require child proof containers for household caustic agents with concentration of 10% or greater and for liquid alkaline products of 2% or greater, have reduced but not eliminated severe caustic injuries in the United States<sup>2,3,4</sup>. In the 12 year period 1988 to 2000, data from the U.S. poison control centre reveal that both the number of household ingestions and number of related deaths have risen, despite public education efforts<sup>5</sup>.

Symptoms and signs are poor indicators of degree and extent of damage to the gastrointestinal tract. Radiological studies are also not sensitive. The best method to stratify patients with acute corrosive ingestion is upper gastro duodenal endoscopy whose

safety has been well established. Flexible endoscopy can be performed safely at any time from 6 to 96 hours of ingestion, provided the patient is stable and there is no evidence of perforation. However, it should be avoided in the sub-acute phase (5 to 15 days) after corrosive intake when the tissues slough and there is increased danger of perforation. On the basis of endoscopic findings, corrosive burns have been classified into grade 0,1,2 and 3 (table 1). Most perforations and fatalities in the acute phase occur in patients with grade 3b injury, while stricture develop in patients with grade 3b injury, while strictures develop in patients with grade 2b or worse injury. Therefore, such patients need to be kept under close supervision<sup>6</sup>.

This is a prospective study of 50 patients with Corrosive Acid ingestion reviewing the extend of injury, clinical outcome and response to treatment.

## II. MATERIAL & METHODS

A total number of 50 patients who were admitted to the Acute Medical Care Ward of Osmania General Hospital, Hyderabad with a history of corrosive acid ingestion were studied.

The initial history was directed towards ascertaining details regarding the corrosive acid consumed i.e. type of acid, concentration, amount and whether the ingestion was suicidal, accidental or otherwise.

The patient was then subjected to a clinical examination including vital signs, oropharyngeal evaluation, chest and abdominal examination. After routine serum chemistry and blood grouping each patient was subjected to plain radiographs of chest and abdomen for evidence of perforation. viz. Pneumo peritoneum, Pneumo mediastinum & pneumo thorax.

When the condition of patient has been stabilized each patient with no clinical evidence of perforation will be subjected within the next 48 hours, under local xylocaine anesthesia esophago gastroduodenoscopy using a flexible Olympus GIF20 endoscope was attempted in all patients, to assess the location, extent and severity of the injury to the upper G.I.tract. The injury was graded according to the modified criteria given by Zargar and colleagues into I, IIa, IIb, IIIa, IIIb, and IV.

**Endoscopic grading of corrosive esophageal and gastric burns is:**

Grade I : edema and erythema

Grade IIA : Hemorrhages, erosions, blisters, superficial ulcer, exudates (patchy or linear)  
Grade IIB : Circumferential lesions  
Grade IIIA : Small scattered areas of necrosis.  
Grade IIIB : Multiple deep brownish-black or gray ulcers with extensive necrosis.  
Grade IV : Perforation

Endoscopy was possible in all patients except patient No. 7 & 2 who had perforated and in whom injury was assessed at surgery, and patient who died within 6 hours, where autopsy was performed.

Upper gastrointestinal endoscopy was repeated at the end of 2 – 4 weeks in all patients with grade IIB injury or more to assess the degree of healing. These patients were also subjected to barium studies (barium swallow and meals) during the early follow up period of up to 2 months to look for development of strictures.

### III. OBSERVATIONS, RESULTS AND DATA ANALYSIS

50 Patients with definite history of Corrosive Acid ingestion of were included in the present study. There were 26 women and 24 men. Their ages ranges from 03 years to 65 years with mean age of 35 years .They are distributed as above.

**CAUSE FOR INGESTION:-** In 9 Patients the injury was accidental while in 41 Patients it was a suicidal attempt, all for the first time.

**NATURE AND AMOUNT INGESTED :-** All Patients had consumed acid in the liquid form. However, the nature of the acid consumed differed. Commonest Corrosive acid ingested was Hydrochloric acid (n = 33) followed by phenyl (n = 9), Sulphuric acid (n = 7) and Nitric acid (n = 1). It was difficult to ascertain the exact volume ingested in each case, but ranged apparently from 20 ml to 100 ml. All patients presented between 1 hour to 10 hours after ingestion with a mean interval of 5.5 hours. Out of 50 patients more than 50% of the Patients presented with Sialorrhoea (n = 45), Epigastric pain (n = 30), Burning sensation in the Oral cavity (n = 28), Odynophagea (n = 29) and Vomiting (n = 27). 50 % of the patients presented with haematemesis (n = 25), less than 50% of the patients presented with other symptoms like dysphagia (n = 22), and heart burn (n = 17). Only one patient presented with respiratory distress.

**PHYSICAL SIGNS :- Oropharyngeal burns:** 66 % of patients (n = 3) presented with burns of either lips, tongue, buccal mucosa, soft palate, hard palate or pharynx.

**Abdominal signs:** 60% of patients had epigastric tenderness (n = 30), 10% patients had diffuse tenderness (n = 5) of which 2 had guarding & 30% had normal abdomen (n = 15).

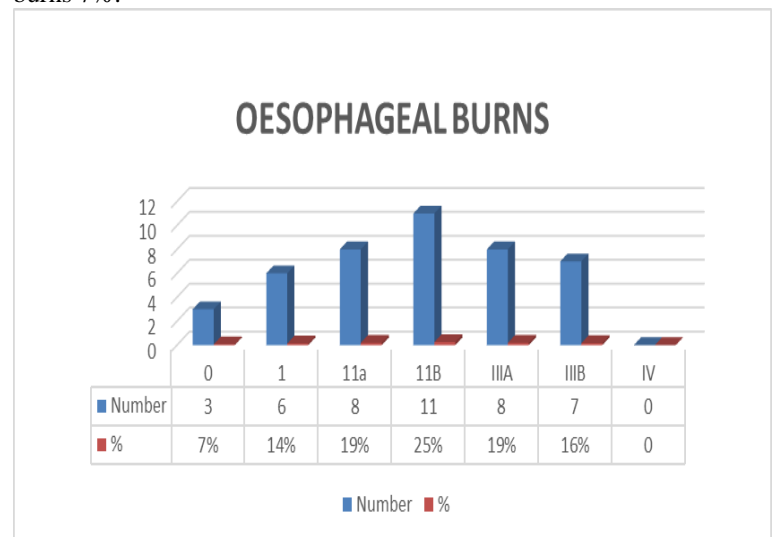
**Endoscopy findings:** Upper GI endoscopy to assess the extent of injury & severity of burns was possible in 43 patients, 2 patients presented with gastric perforation in whom assessment

was done at surgery, in 4 individuals due to severe edema & friability of esophageal mucosa endoscope could not be passed and injuries were assessed at surgery. One patient died & assessed at necropsy.

### OESOPHAGEAL BURNS

Grade	Number	%
0	3	7%
1	6	14%
11a	8	19%
11B	11	25%
IIIA	8	19%
IIIB	7	16%
IV	0	0

60% (n = 26) had severe esophageal burns ( $\geq$  IIB), 19% (n=8) had moderate burns to mild (n = 6), and 14% (n = 3) had no burns 7%.

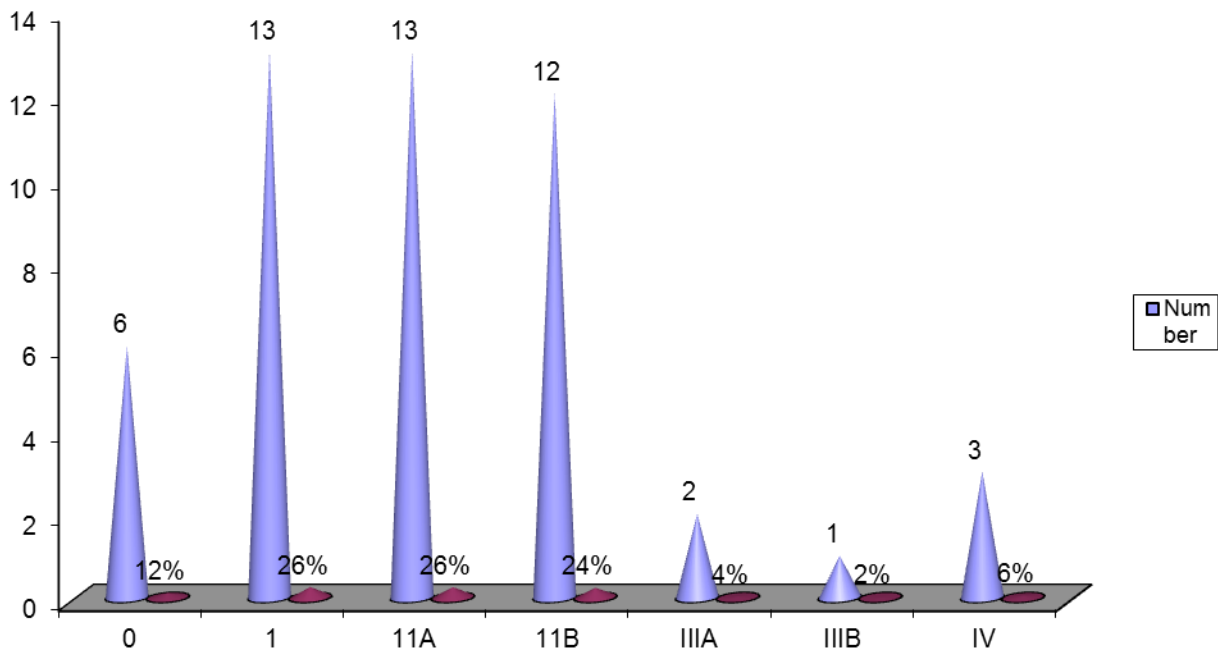


### GASTRIC BURNS

Grade	Number	%
0	6	12%
1	13	26%
11A	13	26%
11B	12	24%
IIIA	02	04%
IIIB	01	02%
IV	03	06%

Severe gastric burns were less when compared with esophageal burns (n = 18). Most of the patients had mild to moderate injuries (n = 26). 3 patients had perforation. 6 patients had no gastric burns.

### Gastric burns



**Duodenal burns:** Scope could not be passed into duodenum in 10 patients due to pylorospasm. 22 patients had no duodenal burns. 15 patients had mild to moderate injuries (I & II) & only 3 patients subjected to surgery had severe duodenal injury (grade III).

17 patients with full stomach had severe esophageal burns, while only 10 had severe esophageal burns with empty stomach. 8 patients on full stomach had severe gastric burns, while 9 patients on empty stomach had severe gastric burns of whom 2 patients presented with perforation. 15 of the 17 patients with no oral cavity burns had esophageal gastric burns, of which 7 had severe injury.

Thus, a normal oral cavity may not exclude upper gastro intestinal injury. 80% of patients (n = 24) with Odynophagia & 83% of patients (n = 26) having dysphagia had severe oesophageal injury (IIB or more). **Haemetemesis:-** 16 patients of 25 patients with haemetemesis had severe injury of esophagus & stomach. **Epigastric pain:-** 19 of 30 patients with severe epigastric pain had severe injury of esophagus or stomach. Of 30 patients with epigastric tenderness 20 patients had esophageal burns & 16 patients had severe gastric burns. One patient with epigastric tenderness and 2 patients with diffuse tenderness had gastric perforation. However, 2 patients with normal abdominal findings had grade IIIA esophageal injury.

#### Management, Complications & Mortality

**Mild to moderate injury:** 23 patients had mild to moderate burns who were kept on IV fluids, nil orally, (soft oral feeds with no evidence of burns) Ampicillin 500mg IV 6<sup>th</sup> hrly. (H2 receptor blockers in symptomatic patients) for first 48 – 72 hours. Gradually put on oral feeds starting with liquids & discharged subsequently.

**Severe injury:** 27 patients had severe burns of esophageas / stomach or both. All the patients were kept on nil orally, IV fluids, Ampicillin IV 500mg 6<sup>th</sup> hrly, proton pump inhibitors 40mg IV BD, and Sucralfate with those IIB & IIIA burns, started oral feeds after 48 hours of which 17 patients did not tolerate oral feeds who were given Naso gastric for 2 weeks. 4 patients with grade IIIB injury were subjected to feeding jejunostomy; of 3 patients with perforation 2 were subjected to laparotomy closure perforation with feeding jejunostomy. One patient died prior to endoscopy. **Mortality:** Overall one patient died with mortality of 2%. No endoscopy related complications were encountered in any patient.

Autopsy was performed in patient who died before initial endoscopy and revealed grade III D esophageal burns and severe lung congestion.

**Repeat Endoscopy after 4 Weeks:-** Of 50 patients – one died before initial endoscopy, after excluding patients with initial normal endoscopy only 20 patients turned up for repeat endoscopy.

**Esophageal :-** 4 of 5 patients with grade IIIB esophageal injury developed stricture lower 1/3 while in one grade IIA injury was found. 3 of 9 patients with IIIA injury developed stricture lower 1/3; in 2 patients there was complete healing in remaining there is decrease in 1 or 2 grades. One of 5 patients with IIB burns developed stricture, in 3 it was normal, in one there is a grade IIA injury. Patient with IIA burns showed normal study.

**Gastric:-** In most of the patients with initial grade IIIB esophageal injuries scope could not be passed down to delineate gastric burns. In most of the patients in whom scope passed showed either normal study or grade IIA injuries.

**Barium Swallow:** - Of 14 patients, with grade IIIA & IIIB injury 11 patients developed stricture lower 1/3 of esophageas. 3 of 5 patients with IIB injury had stricture lower 1/3 of

esophageas. All esophageas stricture occurred in lower 1/3 of esophageas. 2 patients with grade 4 injury had stricture antrum & body. Patient with grade IIIA injury who had stricture antrum & body. 5 of 11 patients with grade IIB injury had stricture antrum. Only one out of 6 patients of IIA injury had stricture antrum. 8 patients developed simultaneous stricture esophagus and stomach. By the end of 8 weeks, 17 patients developed stricture & patients developed stricture antrum or body.

#### IV. DISCUSSION

Corrosive acid injury to upper GI tract due to ingestion is common in India. Most of the patients in present study consumed toilet bowl cleansers which are cheap & easily available. In the present study HCL was the commonest agent ingested 66% (33/50). In studies by zargar et al from Chandigarh HCL<sup>7</sup> (19/41) commonest acid ingested, where as in series of Dilwali et al<sup>8</sup> H2SO4 was the commonest.

Corrosive acid injury to upper GI tract due to ingestion is common in India. Most of the patients in present study consumed toilet bowl cleansers which are cheap & easily available. In the present study HCL was the commonest agent ingested 66% (33/50). In studies by zargar et al from Chandigarh HCL<sup>7</sup> (19/41) commonest acid ingested, where as in series of Dilwali et al<sup>8</sup> H2SO4 was the commonest (10/16) ingested. In present studies 82% (41/50) ingested with suicidal intension. In study by Siva Kumar et al<sup>9</sup> 88.6% ingested with suicidal intension.

Most of the patients presented to the hospital quite early with mean interval between ingestion and admission being 5.5 hours; in contrast to mean interval of 14 hours by Dilwari et al<sup>8</sup>.

54% had severe esophageal injury of which 50% had diffuse involvement & 42% had diffused gastric involvement. Where in study by Shiva Kumar et al<sup>9</sup> of Chennai 69.2% & 65.4% had diffuse esophageal & gastric involvement respectively. Duodenum was relatively spared in majority of patients & in those involved they were mostly of minor grade & this can be attributed to pylorospasm & alkaline PH of duodenum.

Sailorhea (90%) epigastric pain (60%) & dysphagia (62%) were the commonest symptoms encountered. Where as in study by Shiva Kumar et al<sup>9</sup> dysphagia was the commonest symptom (97.1%) encountered.

Grade IIIa injuries & IIIb injuries were present in 16% & 14% of patients, where 46.2% grade III injuries were present in study by Shiva Kumar et al<sup>9</sup>. All the patients with grade IIIb injuries were needed to be subjected for feeding jejunostomy

In this study there is no great difference in severity of injuries in those who consumed on either on full stomach or on empty stomach. However the two patients who presented with perforation consumed acid on empty stomach.

Presence of epigastric tenderness was associated with severe burns of esophagus (64%) & stomach (53%) however 14% of patients with normal abdomen had severe upper gastrointestinal injury, so symptoms & physical examination were unreliable in all cases in determining the severity or extent of injury.

Flexible fiber optic endoscopy made the assessment of upper gastrointestinal injuries accurate, safe, and reliable & practicable. In present study no complications were encountered during early endoscopy. Endoscopy was not only used for evaluating burns, but was also used in deciding treatment & in

assessing healing of burns. Burns were graded according to modified Zargar et al<sup>7</sup> classification.

All patients with minor injuries recovered without any sequel, where as those with severe burns developed acute & late complications.

In present study nasogastric feeding was employed in most patients with severe burns. Feeding jejunostomy was done in six patients of four with grade IIIb injury, two with perforation all these survived through surgery.

Grade III injuries required intensive care & monitoring. There were three patients with gastric perforation of which one died before one day. Site of perforation was cardia in one & greater curvature in two.

Laryngeal edema was present only in child who died before initial endoscopy. Overall mortality was 2% (1 of 50) as compared to (12.2%) & (18.7%) in studies by Zargar et al<sup>7</sup> & Dilwari et al<sup>8</sup>.

Steroids were not used in our study. Mucosal protectants & proton pump inhibitors were used in those with severe injuries for mucosal covering action over ulcer surface & for decreasing acid reflux respectively.

In present study 4 of 5 patients with grade IIIb injury, 3 of 9 patients with grade IIIa injury and 1 of 5 patients with grade IIb injury developed oesophageal stricture and significantly all strictures encountered involved only lower 1/3 of oesophagus. Gastric strictures occurred in two patients with grade IV injury, one with grade III injury, 5 of 11 patients with grade IIb injury and 1 with grade IIa injury as compared to 2 of 6 patients with grade III burns in study by Dilwari et al<sup>8</sup>.

Thus, corrosive acid ingestion though a serious condition with subsequent high degree morbidity and mortality which when attended can be reduced to a certain level.

#### V. CONCLUSION

- (i) Corrosive acid is one of the commonest suicidal agents ingested.
- (ii) Signs and symptoms are unreliable guide to estimate severity in all cases.
- (iii) Early flexible fibre optic endoscopy has a crucial role in both diagnosing the severity of injury as well as in management.
- (iv) Main principle in managing the patients with corrosive injury to upper gastric intestinal tract is that patient should be evaluated individually.
- (v) Diligent follow up is needed to ensure patients to have satisfactory gastro intestinal function.

#### REFERENCES

- [1] Rakesh Kochhar ; Corrosive Poisoning ; Chaper 4 ; Vol I API text book of Medicine 9 edition Pg. no. 1941.
- [2] Di Costanzo J, Noirclerc M, Jouglard J, et al : New therapeutic approach to corrosive burns of the upper gastrointestinal tract. Gut 21 : 370, 1982.
- [3] Haller JA, Andrews HG, White JJ, et al : Pathophysiology and management of acute corrosive burns of the esophagus : results of treatment in 285 children. J Pediatr Surg 6: 578, 1971.
- [4] Lovejoy FH, Woolf AD: Corrosive Ingestion. Pediatr Rev 16: 473, 1995.
- [5] Peter M. Loeb and Micheal J. Nunez; Caustic injury to the Upper Gastrointestinal Tract; Sleisenger & Ford Tran's Gastrointestinal & Liver

diseases, Pathophysiology, diagnosis and treatment 7th edition, Vol. I; Saunders Elsevier Science, Chapter 22nd; Pg No. 399.

- [6] Rakesh Kochhar ; Corrosive Poisoning ; Chaper 4 ; Vol I API text book of Medicine 9 edition Pg. no. 1941-1942.
- [7] Zargar SA, Kochhar R, Nagi B, et al. Ingestion of strong corrosive alkalis; spectrum of injury to upper gastrointestinal tract and natural history. Am J Gastroenterol 1992;87:337-341.
- [8] Dilawari JB, Singh S, Rao PN, et al. Corrosive acid ingestion in man – clinical and endoscopic study. Gut 1984; 25:183-7.
- [9] Shiva Kumar S, Rajan SK, Jayanthi V, Doss Madhu Prabhu CR et al, Corrosive ingestions Acute complications, Japi, vol.51, December 2003.

#### AUTHORS

**First Author** – Dr. B. Sudarsi, M.D., Asst Prof. of Medicine  
Department of Medicine, Osmania General Hospital, Hyderabad,  
Telangana State.

**Second Author** – Dr. K.V.L. Sudha Rani, M.D., Asst Prof. of  
Medicine Department of Medicine, Osmania General Hospital,  
Hyderabad, Telangana State.

**Third Author** – Dr. R. Siddeswari, M.D., Prof. of Medicine,  
Department of Medicine, Osmania General Hospital, Hyderabad,  
Telangana State.

**Fourth Author** – Dr. S. Manohar, M.D., FIAMS, Prof.& HOD  
of Medicine ; Department of Medicine, Osmania General  
Hospital, Hyderabad, Telangana State.



# Stress and Public Sector Managers: A Case of the Government Officers in Nepal

Kedar Rayamajhi

PhD Scholar, Mewar University, India, Senior Director, Nepal Administrative Staff College

**Abstract-** The study of work environment and other job related nexus work related stress is highly relevant for organizational health and performance. This study explores the level of stress among the government officers in Nepal working in different hierarchies using 16 factor framework. Study was conducted among the 284 technical and non-technical government officers. Simple random sampling technique was applied to select the respondents. The study documents several stylized facts about stress in public sector offices in Nepal. Data shows that non-technical officers are at higher stress level in comparison to their technical counterparts. Findings show different factors contribute differently to the job related stress across different hierarchies and nature of work. The study signals policy makers to design necessary organizational coping mechanisms to address the level of stress of working staffs.

**Index Terms-** Stress, Government managers, role ambiguity, role conflict, motivation

## I. INTRODUCTION

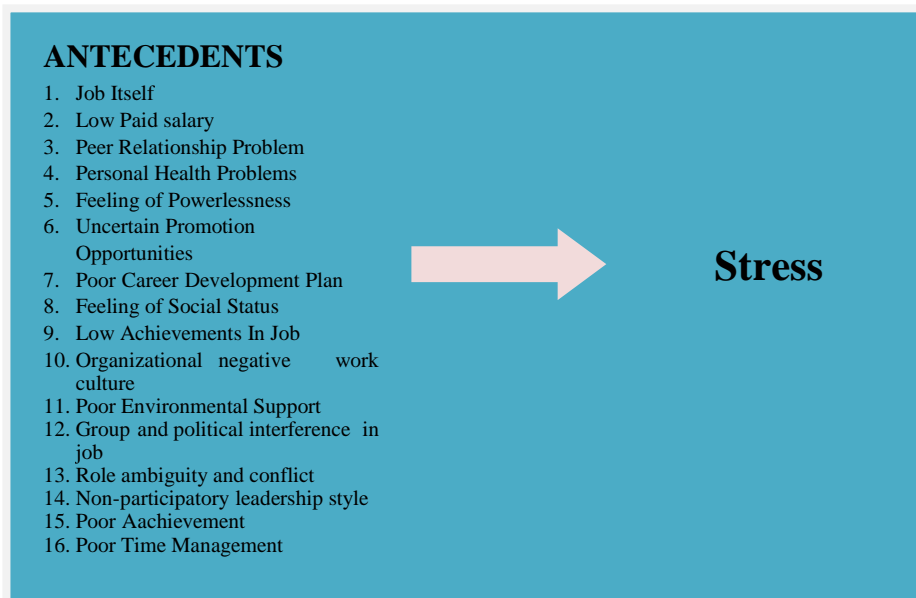
Nepal has undergone series of socio-political changes and the country is experiencing more than decade long transition. Public sector, among others, have greater role to play to produce visible economic performances and ensure socio-political equity, empowerment and inclusion. As such, Nepalese bureaucracy is under pressure to meet paramounting people's expectations, which have been shaped by access to almost-zero global information cost, with limited resources and technologies Public Sector executives are living elements of government organizations, and through them, do these organizations achieve their individual goals directed to national priorities. As such, these public sector managers are under high stress conditions to execute these challenging roles. It is very essential to develop the healthy employee and work cultures to help to create better work environment and can perform effectively to ensure better result. In order to maintain a healthy workforce with the desired level of output in public sector organizations, it is imperative to explore what affects stress of these executives so that appropriate stress management plan can be implemented directed to

optimising desired stress level that promotes performance of these executives.

Stress may have different connotations to different people and under different circumstances. Stress is the reaction that people have to excessive pressure or demands placed on them. Stress arises when people worry that they cannot cope. There are three distinct concepts can be identified. The first concept tasks stress as arousal. It says every individual has a fixed capacity to withstand the pressure and once this limits is exceeded the adverse change takes place and results in stress. The second concept views stress as demands. According to Selye (1956), stress is the organism's response to environmental demand. Stress response is an inherent body mechanism automatically comes into operation whenever demands are placed in the organism. The last concept sees stress as perceived threats of dangers. According to Lazarus (1976) it is neither a stimulus nor a response but arises when an individual perceives and evaluated the situation of threatening. With these concepts one can say stress may originate from a variety of sources. Pestonjee (1992) has identified three sectors of life from which stress may originate. They are: jobs and organization, social and intrapsychic sector. Stress itself is caused by many other factors. Executives are constantly exposed to stress during the work. Although, there is no such accounted figure valued for effect of stress in public sector in terms of loss to individual and work performance, effect must be significant in rupees value to the country. However, management of stress is not possible unless the employee is aware of the specific sources of stress. Considering the level of stress felt by the Government officers of Nepal, the study has focused to identify the stress causing factors of Government officers.

## II. CONCEPTUAL SCHEMA

The sixteen factors models of stress antecedents have been employed to developed research questionnaire. The factors were identified through text book-factors on stress and preliminary interviews with high-level bureaucrats having substantial working experience in Nepalese public sectors.



**Figure 1. 16 factor Schema of factors Causing Work Related Stress.**

**III. METHODS**

The study is based on the quantitative data collected by using the self-reported structured questionnaires. The cross-sectional data was collected to test the hypothesis. The sample of the present investigation comprised of 284 Nepal government employees belonging to section officer level to especial class (Secretary) levels, randomly selected from various Ministries and departments of government of Nepal. The study was conducted in 2013 in Kathmandu valley. The developed questionnaire was pre-tested among the 10% respondent of selected sample size to ensure the reliability and validity of instrument. Data was analyzed by using the SPSS (data analysis software) and descriptive analysis, ANOVA and multiple comparisons was done to present the data. The data presented in tabulation form in result.

**RESULTS**

In this study, out of 284 respondents, 80.3% were male. Similarly, education wise 80.6% had Master degree followed by 17.3% had Bachelor degree and 2.1% had PhD. Researcher has also collected the data from technical and non-technical group so the data shows that 53.5% were from technical field and rest

were non-technical. Respondents were also categorized on the basis of their position. Position comprised from class III to I; the data shows that 56% were from class III followed by 26.4% from class II and 17.6% from class I respectively.

**I. Individual Stress causing factors**

There were various types of stress causing factors measured to know the opinion of respondents regarding their stress. Out of 284 respondents, 158 respondents reported that sometimes their job itself became stress causing factor. Comparatively, higher numbers of respondents reported ‘sometimes’ their low paid salary (101), peer relationship problem (182), personal health problem (179), Feeling of powerlessness (155), Uncertain promotion opportunities (106), Poor career development plan (106), Feeling of social status/recognition (145), Low achievement in job (138), Organizational negative work culture (125), Poor environmental support (140), Group and political interference in job (129), Role ambiguity and conflict (185), Non-participatory leadership style (149), Poor achievement (148) and Poor time management (156) become their stress causing factors (Table 1).

**Table 1: Stress causing factors- descriptive analysis**

<b>Stress Causing Factors</b>						
<b>Factors</b>	<b>Group</b>	<b>Never</b>	<b>Sometimes</b>	<b>Frequently</b>	<b>Always</b>	<b>N</b>
<i>Your Job itself</i>	Class III	17	87	42	13	159
	Class II	14	44	11	6	75
	Class I	6	27	8	9	50
	Total	37	158	61	28	284
<i>Low paid Salary</i>	Class III	12	56	42	49	159
	Class II	5	21	26	23	75
	Class I	7	24	11	8	50

	Total	24	101	79	80	284
<i>Peer relationship problems</i>	Class III	37	103	19	1	159
	Class II	22	47	6	0	75
	Class I	13	32	2	0	50
	Total	72	182	27	1	284
<i>Personal health problems</i>	Class III	34	101	19	5	159
	Class II	22	47	6	0	75
	Class I	17	31	2	0	50
	Total	73	179	27	5	284
<i>Feeling of powerlessness</i>	Class III	26	93	33	7	159
	Class II	19	41	12	3	75
	Class I	19	21	8	2	50
	Total	64	155	53	12	284
<i>Uncertain promotion opportunities</i>	Class III	20	57	46	36	159
	Class II	11	25	18	21	75
	Class I	14	24	9	3	50
	Total	45	106	73	60	284
<i>Poor career development plan</i>	Class III	18	57	53	31	159
	Class II	8	27	20	20	75
	Class I	13	22	8	7	50
	Total	39	106	81	58	284
<i>Feeling of social status/recognition</i>	Class III	28	92	31	8	159
	Class II	20	34	9	12	75
	Class I	18	19	8	5	50
	Total	66	145	48	25	284
<i>Low achievement in job</i>	Class III	21	78	46	14	159
	Class II	13	38	14	10	75
	Class I	21	22	4	3	50
	Total	55	138	64	27	284
<i>Organizational negative work culture</i>	Class III	13	69	49	28	159
	Class II	7	31	30	7	75
	Class I	9	25	15	1	50
	Total	29	125	94	36	284
<i>Poor environmental support</i>	Class III	11	78	48	22	159
	Class II	6	30	30	9	75
	Class I	4	32	10	4	50
	Total	21	140	88	35	284
<i>Group and political interference in job</i>	Class III	11	70	52	26	159
	Class II	10	34	20	11	75
	Class I	9	25	14	2	50
	Total	30	129	86	39	284
<i>Role</i>	Class III	9	103	37	10	159

<i>ambiguity and conflict</i>	Class II	8	50	15	2	75
	Class I	10	32	7	1	50
	Total	27	185	59	13	284
<i>Non-participatory leadership style</i>	Class III	13	70	57	19	159
	Class II	9	44	17	5	75
	Class I	10	35	3	2	50
	Total	32	149	77	26	284
<i>Poor Achievement</i>	Class III	19	86	37	17	159
	Class II	15	40	15	5	75
	Class I	14	22	8	6	50
	Total	48	148	60	28	284
<i>Poor time management</i>	Class III	18	87	40	14	159
	Class II	12	43	15	5	75
	Class I	14	26	7	3	50
	Total	44	156	62	22	284

**Data source:** Field survey, 2013

28 said job itself always became the stress causing factors followed by 80 said low paid salary, 1 said peer relationship problem, 5 said personal health problem, 12 said feeling of powerlessness, 60 said uncertain promotion opportunities, 58 said poor career development plan, 25 said feeling of social status, 27 said low achievement in job, 36 said organizational negative work cultural, 35 poor environmental support, 39 said group and political interference in job, 13 said role ambiguity and conflict, 26 said non-participatory leadership style, 28 said poor achievement and 22 said poor time management.

## II. ANOVA for stress causing factors

There was significant difference found between low paid salary as a stress causing factor and response of government officers at the .012 significant level followed by personal health problem at the .013, uncertain promotion opportunities at .000, Poor career development plan at .008, Low achievement in job at .000, Organizational negative work culture at .009, Group and political interference in job at .012, Role ambiguity and conflict at .008, Non-participatory leadership style at .000 and poor time management at .03 (table 2).

**Table 2: F –test for Stress Causing Factors**

		ANOVA					
	Indicators	Groups	Sum Squares	df	Mean Square	F	Sig.
1	Your Job Itself	Between Groups	2.903	2	1.452	2.21	0.112
		Within Groups	184.562	281	0.657		
		Total	187.465	283			
2	Low paid salary	Between Groups	8.133	2	4.067	4.533	0.012
		Within Groups	252.103	281	0.897		
		Total	260.236	283			
3	Peer relationship problems	Between Groups	0.592	2	0.296	0.844	0.431
		Within Groups	98.489	281	0.35		
		Total	99.081	283			
4	Personal health problems	Between Groups	3.507	2	1.754	4.402	0.013
		Within Groups	111.929	281	0.398		
		Total	115.437	283			
5	Feeling of powerlessness	Between Groups	3.172	2	1.586	2.764	0.065
		Within Groups	161.233	281	0.574		

		Total	164.405	283			
6	Uncertain promotion opportunities	Between Groups	15.309	2	7.655	8.099	0.000
		Within Groups	265.564	281	0.945		
		Total	280.873	283			
7	Poor career development plan	Between Groups	8.948	2	4.474	4.927	0.008
		Within Groups	255.151	281	0.908		
		Total	264.099	283			
8	Feeling of social status/recognition	Between Groups	0.918	2	0.459	0.616	0.541
		Within Groups	209.476	281	0.745		
		Total	210.394	283			
9	Low achievement in job	Between Groups	11.991	2	5.996	8.381	0.000
		Within Groups	201.033	281	0.715		
		Total	213.025	283			
10	Organizational negative work culture	Between Groups	6.678	2	3.339	4.831	0.009
		Within Groups	194.234	281	0.691		
		Total	200.912	283			
11	Poor environmental support	Between Groups	2.616	2	1.308	2.039	0.132
		Within Groups	180.296	281	0.642		
		Total	182.912	283			
12	Group and political interference in job	Between Groups	6.444	2	3.222	4.475	0.012
		Within Groups	202.33	281	0.72		
		Total	208.775	283			
13	Role ambiguity and conflict	Between Groups	4.279	2	2.139	4.933	0.008
		Within Groups	121.876	281	0.434		
		Total	126.155	283			
14	Non-participatory leadership style	Between Groups	13.659	2	6.83	11.546	0.000
		Within Groups	166.211	281	0.591		
		Total	179.87	283			
15	Poor achievement	Between Groups	2.778	2	1.389	1.942	0.145
		Within Groups	200.94	281	0.715		
		Total	203.718	283			
16	Poor time management	Between Groups	4.461	2	2.231	3.561	0.03
		Within Groups	176.003	281	0.626		
		Total	180.465	283			

Data source: Field survey, 2013

The above table presents that there was no significant difference found between job itself as a stress causing factor and response of government officers at the .112 significant followed by Peer relationship problems at .431, Feeling of powerlessness at .065, Feeling of social status/recognition at .541, Poor environmental support at .132 and Poor achievement at .145.

### III. Multiple Comparisons of individual stress causing factors

Multiple comparisons were done to know the mean difference between the classes regarding the different types of stress causing factors.

Table 3: Multiple Comparisons of stress causing factors

Dependent Variable	(I) Position	(J) Position	Mean Difference (I-J)	Std. Error	Sig.
1. Your job itself	Class I	Class III	.079	.131	1.000
		Class II	.280	.148	.178
	Class III	Class II	.201	.114	.234
2. Low paid salary	Class II	Class III	.088	.133	1.000
		Class I	.493*	.173	.014
	Class III	Class I	.405*	.154	.026



3. Peer relationship problems	Class III	Class II	.106	.083	.601
		Class I	.053	.096	1.000
	Class I	Class II	.053	.108	1.000
4. Personal health problems	Class III	Class II	.182	.088	.122
		Class I	.269*	.102	.027
	Class II	Class I	.087	.115	1.000
5. Feeling of powerlessness	Class III	Class II	.145	.106	.515
		Class I	.272	.123	.083
	Class II	Class I	.127	.138	1.000
6. Uncertain promotion opportunities	Class II	Class III	.037	.136	1.000
		Class I	.633*	.177	.001
	Class III	Class I	.596*	.158	.001
7. Poor career development plan	Class II	Class III	.083	.133	1.000
		Class I	.513*	.174	.010
	Class III	Class I	.430*	.155	.017
8. Feeling of social status/recognition	Class II	Class III	.054	.121	1.000
		Class I	.173	.158	.817
	Class III	Class I	.119	.140	1.000
9. Low achievement in job	Class III	Class II	.053	.118	1.000
		Class I	.553*	.137	.000
	Class II	Class I	.500*	.154	.004
10. Organizational negative work culture	Class III	Class II	.085	.116	1.000
		Class I	.419*	.135	.006
	Class II	Class I	.333	.152	.087
11. Poor environmental support	Class II	Class III	.051	.112	1.000
		Class I	.280	.146	.170
	Class III	Class I	.229	.130	.235
12. Group and political interference in job	Class III	Class II	.158	.119	.553
		Class I	.405*	.138	.011
	Class II	Class I	.247	.155	.337
13. Role ambiguity and conflict	Class III	Class II	.155	.092	.281
		Class I	.322*	.107	.008
	Class II	Class I	.167	.120	.500
14. Non-participatory leadership style	Class III	Class II	.276*	.108	.033
		Class I	.576*	.125	.000
	Class II	Class I	.300	.140	.101
15. Poor achievement	Class III	Class II	.194	.118	.309
		Class I	.207	.137	.396
	Class II	Class I	.013	.154	1.000
16. Poor time management	Class III	Class II	.141	.111	.612
		Class I	.334*	.128	.029
	Class II	Class I	.193	.144	.546

**Data source:** Field survey, 2013

The table 3 shows that there was significant difference found between the class II and class I ( $p = .014$ ) and class III and class I ( $p = .026$ ) regarding the low paid salary. Similarly, there was significant difference between class III and class I regarding the personal health problem followed by class II and class I ( $p = .001$ ) and class III and class I ( $p = .001$ ) regarding the uncertain promotion opportunities, class II and class I ( $p = .010$ ) and class III and class I ( $p = .017$ ) regarding the poor career development plan, class III and class I ( $p = .000$ ) and class II and class I ( $p = .004$ ) regarding the low achievement in job, class III and class I ( $p = .006$ ) regarding the organizational negative work culture, class III and class I ( $p = .011$ ) regarding the group and political interference in job, class III and class I ( $p = .008$ ) regarding the

role ambiguity and conflict, class III and class II ( $p = .033$ ) and class III and class I ( $p = .000$ ) regarding the non-participatory leadership style and class III and class I ( $p = .029$ ) regarding the poor time management.

#### IV. Total Stress causing factors

Opinion of respondents was collected to identify the stress causing factors. There was various stress causing factors like interest in job, salary, organizational culture, working environment, achievement, management, peers' relation, personal health ...discussed during the interview survey. The prevalence of total factors on stress was measured by using F-test (table 4).

**Table 4: F-test of total stress causing factors**

Occupation	Sum of Squares	df	Mean Square	F	Sig.
Between Groups	995.016	2	497.508	9.731	.000
Within Groups	14366.206	281	51.125		
Total	15361.222	283			

**Data source:** Field survey, 2013

There was significant difference found between the total stress causing factors and response of respondents at  $f = 9.731$ ,  $p = .000$  significant level.

**V. Multiple Comparisons of total stress causing factor**

**Table 5: Multiple Comparisons of total stress causing factors**

(I) Position	(J) Position	Mean Difference (I-J)	Std. Error	Sig.
Class III	Class II	1.384	1.002	.504
	Class I	5.111*	1.159	.000
Class II	Class I	3.727*	1.305	0.014

Note: \* the mean difference is significant at the 0.05 level.

**Data source:** Field survey, 2013

The data shows that there was significant difference found between the class III and I at the .000 followed by class II and I at the .014 on total stress causing factors in their mental health. Similarly, there was no significant difference found between the class III and II because p values is .504 which is greater than .05. It can be assumed that the perception of class II level staffs on their stress causing factors was different than the class III.

**IV. DISCUSSIONS**

Kyriacou (1989) defined stress as an unpleasant emotional state, resulting from prolonged, increasing, or even new pressures, which are perceived as significantly greater than the individual's coping resources. In organisational behaviour literature, employee stress has attracted considerable attention, as it appears to impact upon a person's overall performance, both in terms of productivity and delivery of services (McShane & Von Glinow, 2005).

The study found that there is significant difference found among stress caused by job nature itself across different hierarchical position. The reason may be attributed to missing like of position and accompanying function or responsibility. The study reveals significant difference in salary payment or low paid salary as stress causing factor. It shows that low paid salary is significantly higher in class III and II in comparison to class I level which may be the reflection of ample alternative income generation sources in high level position.

Previous study also found that the many job condition factors proposed as sources of stress at work, role stress has been widely recognized as an antecedent of occupational stress (e.g. Cooper & Marshall, 1976). In any organizations, Occupational stress has been noted as a hazardous for employees. Evidence has been indicated that occupational stress is related to psychological and physical well-being, job satisfaction, absenteeism, turnover rate and intent to quit (Ganster & Schaubroeck, 1991; Sullivan & Bhagat, 1992). One of the most damaging effects of work

stress is its impact on the economy. Cooper and Cartwright (1996) estimated that overall 360 million working days are lost in the UK annually through sickness; out of which about half are stress related. Therefore it is important to identify the potential occupational stressors, and to find variables which have beneficial consequences for both employees and organisations.

The present study surprisingly presented that personal health problem of lower level officer (class III) is significantly higher than the higher level officers (class I). The study warns serious response bias may have accounted this misleading inference however, this may also signal negative change of perceptive health well-being to powerlessness. The study documents strong evidence of feeling of powerlessness among junior level officer in comparison to senior level officer. In other words, feeling of problems decreases among civil servant as they climb positional level. Chiu and Kosinski (1995) argued that stress is influenced by cultural and social variables such as values, attitudes, and perception. One important attitudinal variable as such is organisational commitment. Sommer, Bae, and Luthans (1996) contended that organisational commitment is one of the important variables in the study of employee behaviour since it is inversely related to employee tardiness and absence (e.g. Cohen, 1993); moreover, highly committed employees have higher productivity and are willing to assume responsibility (Chow, 1990).

Organizational commitment becomes stronger when employee will be optimistic for their better carriers. The present study indicated that there is higher uncertainty regarding promotion opportunities in level II and III whereas less uncertainty exists for class I officers. This finding is in line with existing government policies and practices that favour class I officer for promotional certainty in comparison to lower level officers. The finding also indicates that poor career development seems to affect lower level officer (class III and II) more than class I officer. This is in line with previous finding of uncertainty promotion being high to the lower level officer. The study also

found that organization work culture in civil service is perceived negatively by the lower level officers (class II and III) in comparison to higher level officer (class I). From leader follower perspective the finding is in line with existing practices where higher level leadership consider themselves right even when followers perceive them the wrong direction of leadership.

Moreover, organisational commitment has also been found to be a stress moderator (e.g. Begley & Cazjka, 1993). The mechanism might be that, due to their positive attitudes, committed employees are less distressed by occupational stressors and therefore they perceive less stress. By and large almost all work stress research and theories were developed and empirically tested in Western industrialized countries (Jamal, 1999; Xie, 1996). It is therefore important to replicate job stress research in Nepalese societies in order to test the generalisability of Western organisational theories. Van Katwyk, Fox, Spector and Kelloway (2000) found that negative affectivity played an important role in determining the influence of job stress on the physical health of employees. Additionally, in their review of the literature, Hurrell and colleagues (1998) discuss how negative affectivity mediates the effects of stress on physical health among teachers.

The study finding revealed that there is no difference among different level of officers on the perception of social recognition. The reason may be society has given due importance (till this time value seems to be positive towards government job) government service irrespective of their position. This study documents significant positive association between job achievement and hierarchical position. Limited delegated authority, poor exposure and resources can be attributed to low achievement among lower level officer (class II and III). The study also explored that higher level of political interference in job by lower level officer (class III). The reason may lower level officer would be unable to resist different kinds of pressure in their workplace whereas higher level officer (II and I) pass the accountability either to lower side or to the higher side. The study found that role ambiguity and conflict is higher for lower level officer (III). The reason may be attributed to the mismatch of role assignment to job requirement. The study shows that lower level officers perceiving high non participatory style of leadership in their workplace whereas high level officer perceive the other way.

The study shows that the achievement orientation across different hierarchical position to be non significant. The study found that poor time management has significant effect on stress to the lower level officer (III) which may be due to high role ambiguity, role conflict and higher of powerlessness.

## V. CONCLUSION

Stress is the mental construction caused by various environmental and individual factors. Stress results the mental as well as physical health problem. Government officers are suffered by work stress. There are various factors are identify as the causative factors; low paid salary, peer relationship problem, personal health problem, Feeling of powerlessness, Uncertain promotion opportunities, Poor career development plan, Feeling of social status/recognition, Low achievement in job, Organizational negative work culture, .Poor environmental

support, Group and political interference in job, Role ambiguity and conflict, Non-participatory leadership style, Poor achievement and Poor time management. There was significant difference found between the total stress causing factors and response of total government officers within and between the groups. The future research can be done to identify the best way to manage the stress and reduce the mental and health problem.

## ACKNOWLEDGEMENT

I would like to thank my research supervisor Prof. Dr. Murari Prasad Regmi for his close guidance to conduct this research. I appreciate cooperation of my junior colleague Mr. Santosh Koirala from Nepal Administrative Staff College in quantitative analysis of the collected data. I also express my sincere gratitude to Mewar University to provide me platform for research.

## REFERENCES

- [1] Begley, T.M., & Cazjka, J.M. (1993). Panel analysis of the moderating effects of com-mitment on job satisfaction, intent to quit, and health following organizational change. *Journal of Applied Psychology*, 78(4), 552-556.
- [2] Cohen, A. (1993). Organizational commitment and turnover: A meta-analysis. *Academy of Management Journal*, 36(5), 1140-1157.
- [3] Chiu, R.K., & Kosinski, F.A. Jr. (1995). Chinese cultural collectivism and work-related stress: Implications for employment counselors. *Journal of Employment Counseling*, 32,98-110.
- [4] Chow, I.H.S. (1990). An empirical assessment of organizational commitment among local employees. *Human Resources Journal*, 6(1), 32-38.
- [5] Cooper, C.L., & Cartwright, S. (1996). *Mental health and stress in the workplace: A guide for employers*. London: HMSO.
- [6] Cooper, C.L. & Marshall, J. (1976). Occupational sources of stress: A review of the literature relating to coronary heart disease and mental ill-health. *Journal of Occupational Psychology*, 49,11-28.
- [7] Kyriacou, C. (1989) 'The nature and prevalence of teacher stress' in M. Cole & S. Walker (eds) *Teaching and Stress*. Milton Keynes: Open University Press.
- [8] McShane, S. & Von Glinow, M. A. (eds) (2005) *Organizational Behaviour*. New York: McGraw-Hill/Irwin.
- [9] Ganster, D.C., & Schaubroeck, J. (1991). Work stress and employee health. *Journal of Management*, 17, 235-272.
- [10] Hurrell, J. J. Jr., Nelson, D. L. & Simmons, B. L. (1998) 'Measuring job stressors and strains: where we have been, where we are, and where we need to go', *Journal of Occupational Health Psychology*, 3 (4), 368-389.
- [11] Jamal, M. (1999). Job stress, Type-A behavior, and well-being: A cross-cultural examination. *International Journal of Stress Management*, 6, 57-67.
- [12] Pestonjee, D. M. (1992). *Stress and Coping: The Indian Experience*. New Delhi: Sage. *Journal of Health & Social Behavior*, 23,159-169.
- [13] Semmer, N. (1996). Individual differences, work stress and health. In M.J.Schabracq, J.A.M. Winnubst, & C.L. Cooper (Eds.), *Handbook of Work and Health Psychology* (pp. 51-86).
- [14] Sullivan, S., & Bhagat, R.S. (1992). Organizational stress, job satisfaction and job performance: Where do we go from here? *Journal of Management*, 18, 353-374.
- [15] Van Katwyk, P. T., Fox, S., Spector, P. E. & Kelloway, E. K. (2000) 'Using the Job-related Affective Well-being Scale (JAWS) to investigate affective responses to work stressors', *Journal of Occupational Health Psychology*, 5, 219-230.
- [16] Xie, J.L. (1996). Karasek's model in the People's Republic of China: Effects of job demands, control, and individual differences. *Academy of Management Journal*, 39, 1594-1618.

AUTHORS

**First Author** – Kedar Rayamajhi, PhD Scholar, Mewar  
University, India, Senior Director, Nepal Administrative Staff  
College, Email: rkedarp@yahoo.com

# Textile Application of Natural Colourant from the Roots of *Eichhornia crassipes* (Mart.) Solms

Robin<sup>1</sup>, Ashwani Kumar Thukral<sup>1</sup> and Varinder Kaur<sup>2</sup>

<sup>1</sup>Department of Botanical & Environmental Sciences, Guru Nanak Dev University, Amritsar-143005, Punjab, India

<sup>2</sup>Department of Applied Chemical Sciences & Technology (Textile Chemistry), Guru Nanak Dev University, Amritsar-143005, Punjab, India

**Abstract-** *Eichhornia crassipes* (Mart.) Solms is a free-floating aquatic macrophyte growing normally to a height of 0.5 m to 1 m. This weed causes, substantial economic and ecological harm, warranting its removal, lest the impacts of the weed should become permanent. From an ecological perspective, the most effective, management approach is to make use of the weed for various purposes. The present study offers the novel scheme for utilization of roots of this invasive weed plant. In this instance the 80% methanol extract and methanol fraction from the roots of this weed were tested for its colouring properties on different textile substrates viz. wool, nylon, silk, cotton and polyester. Open beaker and infra red colouring based methods were utilized for colouring of different textile fabric substrates. The colour fastness testing and colorimetric evaluation of the coloured samples has been carried out employing standard methods. The 80% methanol extract as well as the methanol fraction exhibited good colouring property on wool, nylon and silk. The presence of alkaloids, flavonoids, tannins, terpenoids, quinones, phenols and other phytochemicals enables good colour yield/depth of 80% methanol extract and methanol fraction on substrates. Thus, the colour extract from the roots may prove to be effective for conventional colouring and may provide commercial importance of this natural colourant for textile applications.

**Index Terms-** *Eichhornia crassipes* (Mart.) Solms; natural colour; roots.

## I. INTRODUCTION

*Eichhornia crassipes* (Mart.) Solms is a free-floating aquatic macrophyte growing normally 0.5 m to 1 m in height. The plant roots are fibrous, purplish black and feathery. It is a South American native and is thought to have originated in the Amazon basin [1]. The weed has beautiful large purple and violet flowers which make it popular ornamental plant for ponds. The Invasive Species Specialist Group (ISSG) has included this weed in a database of "100 of the world's worst invasive alien species". This invasive weed is now found in more than 50 countries in five continents [2].

The weed spread between continents and watersheds is mainly the result of its floating propagules and via human activities [3]. The weed plant populations have been known to double in just 12 days [4]. This aquatic weed reproduces both sexually and asexually, and has high growth rates [3]. Infestations of this weed block waterways, limiting boat traffic, swimming, fishing, causing impaired efficiency of irrigation and hydro power generation, reducing biodiversity and its

conservational value by preventing sunlight and oxygen from reaching the water column, and changes the population of vectors of human and animal diseases [3-7].

The aquatic weed grows in shallow temporary ponds, wetlands and marshes, sluggish flowing waters, lakes, reservoirs and rivers. The aquatic weed plants can tolerate extreme fluctuation of water level and seasonal variations in flow velocity, and extremes of nutrient availability, pH, temperature and toxic substances [4]. The average annual productivity of *E. crassipes*, is 50 tons ash-free dry weight basis per hectare per year, which makes it one of the most productive plants in the world [8-9]. Due to its uncontrolled and rapid growth, *E. crassipes* has apparently become a problem in different parts of the world, and therefore there is a need to manage its spread through suitable control measures [9].

Control management strategies for *E. crassipes* can be watershed management (to reduce nutrient supply) and direct weed control (e.g. by introduction of biological control agents) [4]. The main management approaches are physical, chemical and biological control. However, the reality remains persistent that this invasive weed has effectively resisted all attempts of its eradication by chemical, biological, mechanical, or hybrid means [8-10]. Thus, from an ecological perspective, the simplest, and usually least expensive, management approach is to make use of the weed for various purposes like phytoremediation, power alcohol production, biogas production, in compost, in animal fodder/fish feed, etc. [9].

The present work has been undertaken for utilization of root extract of this invasive weed plant as a natural colourant on different textile fabric substrates viz. wool, nylon, silk, cotton and polyester, so as to determine its utility for human welfare.

## II. MATERIALS AND METHODS

The plant material of *Eichhornia crassipes* (Mart.) Solms were collected from Harike wetland in The Tarn Taran district of the Punjab state in India. The plants were grown in Hoagland solution. The roots were separated from mature plant and utilized for the present study.

### 2.1 Preparation of crude extract

The dried roots were chopped into small pieces and extraction from roots was carried out thrice in 80% methanol. The dried roots were soaked in a 100:1 (v/m) ratio of 80% methanol and shaken continuously for 2 days on a shaker platform, at 25 °C temperature. The supernatant was collected and filtered with Whatman number 1 filter paper. The extract



filtrate was dried in rotary evaporator under vacuum, weighed and stored in dry solid form until required.

## 2.2 Polarity wise separation of crude extract

The separation of crude extract was carried out, from lower to higher polarity solvents. The separation was performed with diethyl ether, chloroform and methanol by separating contents of crude extract dissolving in respective solvents.

Out of the crude extract and its fractions, the crude and methanol fraction was utilized as a natural colourant, due to its higher polarity, amount and comparatively better dissolving property in deionised water.

## 2.3 Phytochemical screening of crude extract and methanol fraction [11-12]

### 2.3.1 Alkaloids

**2.3.1.1 Mayer's test:** About 0.5-1 ml of extract/fractions was treated with few drops of Mayer's reagent. Formation of cream coloured precipitates confirms the presence of alkaloids.

### 2.3.2 Flavonoids

**2.3.2.1 NaOH test:** About 0.5-1 ml of extract/fractions was treated with aqueous NaOH and HCl. Formation of yellow orange colour precipitates confirms the presence of flavonoids.

**2.3.2.2 H<sub>2</sub>SO<sub>4</sub> test:** A fraction of extract/fractions was treated with concentrated H<sub>2</sub>SO<sub>4</sub>. The presence of flavonoids was confirmed by the formation of orange colour.

### 2.3.3 Tannins

**2.3.3.1 FeCl<sub>3</sub> test:** About 0.5-1 ml of extract/fractions was treated with 0.1% FeCl<sub>3</sub>. Formation of brownish green or blue black colour confirms the presence of tannins.

### 2.3.4 Terpenoids

**2.3.4.1 Salkowski Test:** About 0.5-1 ml of extract/fraction was treated with CHCl<sub>3</sub> and few drops of concentrated H<sub>2</sub>SO<sub>4</sub> and shaken vigorously. Formation of yellow colour at lower layer confirms the presence of terpenoids.

### 2.3.5 Anthocyanins

**2.3.5.1 NaOH test:** About 0.5-1 ml of extract/fractions was treated with 2 M aqueous NaOH. The presence of anthocyanin was detected by the formation of blue green colour precipitates.

### 2.3.6 Quinones

**2.3.6.1 HCl test:** A fraction of extract/fractions was treated with concentrated HCl. Formation of yellow colour precipitates confirms the presence of quinones.

### 2.3.7 Phlobatanins

**2.3.7.1 HCl test:** A fraction of extract/fractions was boiled with 1% aqueous HCl. The red coloured precipitates formation confirms the presence of phlobatanins.

### 2.3.8 Phenols

**2.3.8.1 FeCl<sub>3</sub> test:** A fraction of extract/fractions was treated with 5% FeCl<sub>3</sub>. Formation of deep blue/black colour confirms the presence of phenols.

**2.3.8.2 Liebermanns test:** A fraction of extract/fractions was heated with sodium nitrite, treated with H<sub>2</sub>SO<sub>4</sub> solution, diluted with water and excess of dilute NaOH was added. The presence of phenols was confirmed by the formation of deep red or green colour.

**2.3.9 Saponins:** A small amount of extract/fractions was mixed with water and shaken vigorously for stable persistent froth. The frothing was mixed with 3 drops of olive oil and shaken vigorously. Formation of emulsion confirms the presence of saponins.

## 2.4 Colouring procedure:

The colouring characteristics of crude and methanol fraction on different substrates like wool, nylon, silk, cotton and polyester were carried out employing open beaker colouring and IR-heated lab colouring using Infra-colour (RBE, Mumbai) machine. The colourant bath was prepared using crude extract and methanol fraction in deionised water.

### 2.4.1 Open beaker colouring

Colouring of substrates in open beaker was performed on water bath. The colourant bath was maintained at pH 4 by using glacial acetic acid. Temperature was raised to 100 °C and colouring was carried for one hour. Subsequently, substrate samples were rinsed in cold water. The samples were washed in a bath of liquor to material ratio of 20:1 using 0.5 g/l nonionic detergent at 60 °C for 15 minutes and dried at ambient temperature.

### 2.4.2 Infra-red colouring

High temperature colouring was performed on polyester using Infra-colour (RBE, Mumbai) machine. The colourant bath was maintained at pH 4. Process was carried out by raising the colourant bath temperature from 20 °C to 130 °C at 4 °C/min, for 60 min and rapidly cooling (9.9 °C/min) to 50 °C as shown in **Figure 1**. The coloured samples were rinsed with cold water and reduction cleared at 70 °C for 15 minutes. Subsequently, samples were rinsed successively with hot water detergent solution (70 °C, 5 min) and cold water. The samples were air dried at ambient temperature.

The colouring was carried out by open beaker colouring method and Infra-red colouring based method with colouring conditions and sample codes as shown in **Table 1**.

## 2.5 Fastness testing and colorimetric evaluation:

The coloured samples were tested according to standard methods. The specific tests were as follows: ISO CO6 C2S, colour fastness to washing test; IS-766-88, colour fastness to rubbing; and ISO 105-B02, colour fastness to light (xenon arc) [13]. The colorimetric evaluations of coloured samples were determined using Spectraflash 600 colorimeter (Datacolor International) using CIELAB, 1976. Colour space, D<sub>65</sub> illuminant, 10° observer [14].

### 2.5.1 Colour fastness to washing

Standard method for testing colour fastness to washing (ISO 105 CO6 C2S) was performed on coloured samples. ECE reference detergent (4 g/l), sodium perborate (1 g/l) and steel balls were employed in the test and pH 10.5 was maintained using sodium carbonate if required. Coloured samples strips of 10×4 cm dimension were cut and stitched through the short end of SDC's multifibre test fabric. The test was performed on Washtech (RBE, Mumbai) at 60 °C for 30 minutes. Then samples were rinsed with cold deionised water and air dried at ambient temperature.

### 2.5.2 Colour fastness to rubbing

Standard method testing for colour fastness to rubbing (IS-766-88) was performed on coloured samples using crockmeter with dry white piece and wetted white piece of cotton fabric. The

amount of colour fastness and staining was assessed against grey scale by colorimetric analysis.

### 2.5.3 Colour fastness to light

Standard method testing for colour fastness to light (ISO 105-B02) was performed on coloured samples by xenon arc fading lamp test using blue wool reference sample.

### 2.5.4 Absorbance and colour strength evaluation

The absorbance of the colour baths was recorded before and after colouring on a Systronics PC based double beam spectrophotometer 2202. The colour strength (*K/S*) values of the coloured samples were evaluated by light reflectance technique and the values were assessed using spectraflash 600 colorimeter (Datacolor International).

### 2.5.5 Colorimetric analysis

The colorimetric analysis of coloured samples was evaluated at  $D_{65}$  illumination,  $10^\circ$  observer using spectraflash 600 colorimeter (Datacolor International).

## 2.6 Toxicity testing

Kirby-Bauer Disk Diffusion Susceptibility Test of crude extract was carried out on wild strain of *Escherichia coli* and *Bacillus subtilis* [15-16] with ampicillin as positive control. The filtrates were obtained from dyed fabric, using a liquor ratio of 1g fabric/20 ml of sterilized  $H_2O$  at  $20^\circ C$ , shaken and incubated for 18 h at  $37^\circ C$  [17]. Preparation of overnight bacterial culture was carried out using autoclaved Luria Broth (LB) medium (2%) in deionised water on shaker at  $37^\circ C$  for bacterial growth. The turbidity of the medium justifies the growth of the bacterial strains. The autoclaved LB-agar medium (LB-2% and agar-1.5%) was prepared and poured into autoclaved and sterilized petri dishes (90 mm) in a laminar hood. The medium was allowed to come at room temperature. The autoclaved top agar medium (agar and NaCl) was prepared and subsequently used for inoculating and spreading of bacterial strains ( $100 \mu l$  petridish<sup>-1</sup>) on to solidified LB-agar medium. Disks of 4 mm diameter were prepared by Watman number 1 filter paper, autoclaved and sterilized. The appropriate filtrate-impregnated sterilized disks were placed on the surface of the LB-agar, using sterilized forceps. Once all disks were placed, incubation was carried out in a  $37^\circ C$  air incubator for 24-48 h. Following incubation, zone sizes were measured to the nearest millimeter using a ruler.

## III. RESULTS AND DISCUSSION

The crude extract yield was found to be 6% of total dry weight of roots. The methanol fraction yield out of crude extract was found to be over 50% of total weight of crude extract. The colour of crude extract appears to be black brown and methanol fraction appears to be reddish brown. The results of the presence/absence of the various phytochemicals in the crude extract and methanol fraction of the roots of *Eichhornia crassipes* (Mart.) Solms are shown in the **Table 2**. The presence of different phytochemicals enables good colour yield/depth of crude extract and methanol fraction on substrates, which may be attributed by synergistic effect of mixture many innate compounds within plant roots.

Initially the colouring on substrates like wool, nylon, silk, cotton and polyester were carried out to select fabric with maximum and constant colour yield. Colouring of substrates *viz.*

wool, nylon, silk and cotton were initially performed by open beaker colouring method. Resulted samples showed maximum colour yield on wool and nylon, moderate on silk and minimum on cotton substrate.

High temperature colouring was performed on polyester using Infra-colour (RBE, Mumbai) machine by IR-heated lab colouring method. Resulted sample showed different hues on substrate but with good colour yield. Therefore, polyester was not employed for further colouring process due to unevenness of colour on the sample.

The results showed that colour diffusion into wool, nylon and silk was maximum, which may be due to the presence of functional groups *viz.*  $-NH_2$ ,  $-COOH$  and  $-CO-NH-$  in the fiber. Considering the results, wool, nylon and silk were preferred for colouring.

The fastness properties of the coloured fabrics are shown in **Table 3**. The results of colour fastness to washing in terms of grey scale ratings showed good fastness properties for WCF and SCF, moderate rating for NMF, average ratings for WMF and NCF and below average rating for SMF. The results of colour staining to washing showed good fastness properties except WCF and NCF which showed moderate fastness ratings on multifibre strips towards acrylic component and worsted wool component respectively.

The results of colour fastness to light showed moderate rating for WMF and WCF and average rating for SMF and SCF on grey scale. The results of colour fastness to rubbing showed moderate to good fastness properties on grey scale ratings. The results of colour staining to rubbing showed good to excellent fastness results on grey scale ratings.

The colourant bath made from crude extract and methanol fraction were evaluated for its absorbance before and after colouring of samples as shown in the **Figure 2**. The absorbance graphs clearly show the good colour uptake by fabric samples. Also, **Figure 3** shows the *K/S* graphical representation of coloured samples after colouring from crude extract and methanol fraction, in which continuous line represents wool, square bulleted line represents nylon and dotted line represents silk. The *K/S* graph clearly represents that nylon samples show maximum absorbance of colour whereas wool and silk shows minimum absorbance in case of colouring from crude extract and from methanol fraction respectively.

The evaluations of colour-coordinates of coloured samples are shown in **Table 4**. All colour-coordinates are positive with respect to brightness  $L^*$ , red-green  $a^*$ , yellow-blue  $b^*$ , chroma  $C^*$  and hue  $h$ . The colour yield on wool and nylon appears to be yellowish light brown and light brown respectively; simultaneously, the colour yield on silk appears to be golden yellowish brown for methanol fraction and golden light brown for crude extract, as shown in **Figure 4** and **5**.

The filtrates from dyed fabrics were found to show no toxic effect on both bacterial strains used (*B. subtilis* and *E. coli*) in disc diffusion assay as shown in **Fig. 6** and **7**. This study shows that the dyes were not toxic to both gram positive and gram negative bacterial strains.

#### IV. CONCLUSION

It may be concluded that the colouring from the crude extract of the roots of *Eichhornia crassipes* (Mart.) Solms appears to be simple and cost effective management approach to make use of this weed for textile applications. The colouring effect may be attributed due to the synergistic effect of alkaloids, flavonoids, tannins, terpenoids, quinones, phenols and other phytochemicals present within the plant roots. The coloured substrates showed better fastness properties especially on wool substrate, however all substrates showed good colour depth/yield. The work may provide basis for utilization of roots of this invasive plant on commercial scale.

#### REFERENCES

- [1] S C H Barrett and I W Forno, *Aquat. Bot.*, 13 (1982) 299.
- [2] S Lowe, M Browne, S Boudjelas, M De Poorter (The Invasive Species Specialist Group (I S S G) a specialist group of the Species Survival Commission (SSC) of the World Conservation Union (I U C N). New Zealand: Hollands Printing Ltd., 2004) 1.
- [3] G W Howard, K L S Harley. *Wetl. Ecol. Manag.*, 5 (1997) 215.
- [4] G I S D, Global Invasive Species Database (The Invasive Species Specialist Group (ISSG) a specialist group of the Species Survival Commission (SSC) of the World Conservation Union (IUCN), 2006) Internet source accessed: June, 2013; [<http://www.issg.org/database>].
- [5] S R Biswas, J K Choudhury, A Nishat, M M Rahman, *For. Ecol. Manag.*, 245 (2007) 1.
- [6] W Cheng, C Xuexiu, D Hongjuan, L Difun, L Junyan, *Acta. Ecol. Sin.*, 28 (2008) 2595.
- [7] W F Masifwa, T Twongo, P Denny, *Hydrobiologia*, 452 (2001) 79.
- [8] S A Abbasi, E V Ramasamy, (Hyderabad: Universities press India Ltd., Orient Longman, 1999) 168.

- [9] A Malik, *Env. Int.*, 33 (2007) 122.
- [10] S A Abbasi, (New Delhi: Discovery Publishing House, 1998) 12.
- [11] N Lata, V Dubey, *J. Pharm. Res.*, 3 (2010) 1240.
- [12] P Jayanthi, P Lalitha, S K Sripathi, *J. Pharm. Res.*, 4 (2011) 1405.
- [13] Society of Dyers and Colourists, (Great Britain: SDC, Bradford, 1990).
- [14] J Schanda, (New Jersey: John Wiley & Sons, Inc., 2007) 25.
- [15] A W Bauer, D M Perry, W M M Kirby, A. M. A. *Arch. Intern Med.*, 104 (1959) 208.
- [16] A W Bauer, W M M Kirby, J C Sherris, M Turck, *Am. J. Clin. Pathol.*, 36 (1966) 493.
- [17] K Klemola, J Pearson, A von Wright, J Liesivuori, P Linderstrom-Seppe, *AUTEX Res. J.* 7 (2007) 224.

#### AUTHORS

**First Author** – Robin, Department of Botanical & Environmental Sciences, Guru Nanak Dev University, Amritsar-143005, Punjab, India

**Second Author** – Ashwani Kumar Thukral Department of Botanical & Environmental Sciences, Guru Nanak Dev University, Amritsar-143005, Punjab, India

**Third Author** – Varinder Kaur, Department of Chemistry (Textile Chemistry), Guru Nanak Dev University, Amritsar-143005, Punjab, India

**Correspondence Author:** Dr. Varinder Kaur, Assistant Professor (Textile Chemistry), Department of Chemistry, Guru Nanak Dev University, Amritsar-143005, Punjab, India, E-mail: [varinder\\_gndu@yahoo.com](mailto:varinder_gndu@yahoo.com), Cell phone: +91-9888504121.

#### Table Captions

**Table 1** Colouring conditions for different samples

**Table 2** Qualitative estimation of phytochemicals in the crude extract and methanol fraction of the roots of *Eichhornia crassipes* (Mart.) Solms

**Table 3** Colour fastness data<sup>a</sup> of the colour on samples

**Table 4** Colorimetric data for coloured samples

#### Figure captions

**Fig. 1** Colouring profile

**Fig. 2** Absorbance of colourant bath before and after colouring of substrates

**Fig. 3** K/S graphical representation of coloured substrates after colouring

**Fig. 4** Colour of the samples from methanol fraction

**Fig. 5** Colour of the samples from crude fraction

**Fig. 6** Disk Diffusion assay on *Bacillus subtilis*

**Fig. 7** Disk Diffusion assay on *Escherichia coli*

**Table 1**

Sample	Sample codes	Colouring method
Wool (methanol fraction)	WMF	Conventional colouring (at boil)
Nylon (methanol fraction)	NMF	Conventional colouring (at boil)
Silk (methanol fraction)	SMF	Conventional colouring (at boil)
Wool (crude extract)	WCF	Conventional colouring (at boil)
Nylon (crude extract)	NCF	Conventional colouring (at boil)
Silk (crude extract)	SCF	Conventional colouring (at boil)

**Table 2**

S. No.	Phytochemicals	Tests	Crude extract	Methanol fraction
1.	<u>Alkaloids</u>	Mayer's test	+	+
2.	<u>Flavonoids</u>	NaOH test H <sub>2</sub> SO <sub>4</sub> test	+	+
3.	<u>Tannins</u>	FeCl <sub>3</sub> test	+	-
4.	<u>Terpenoids</u>	Salkowski test	+	+
5.	<u>Anthocyanins</u>	NaOH test	-	-
6.	<u>Quinones</u>	HCl test	+	+
7.	<u>Phlobatannins</u>	HCl test	-	-
8.	<u>Phenols</u>	FeCl <sub>3</sub> test Liebermann's test	+	+
9.	<u>Saponins</u>	Froth test	-	-

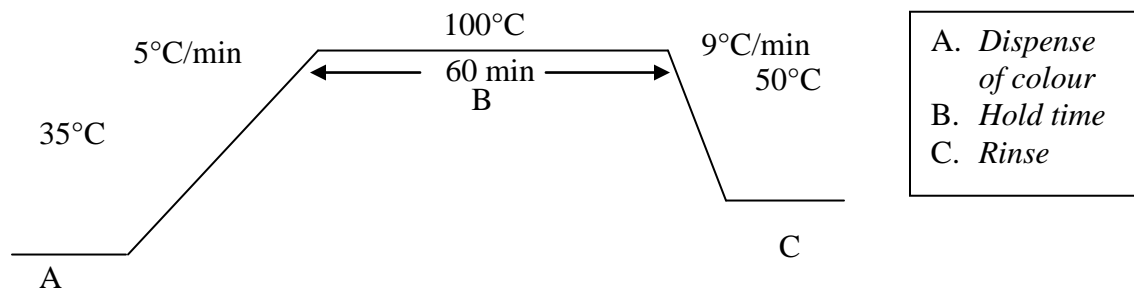
**Table 3**

Sample code	Washing fastness							Light fastness	Rubbing fastness			
	Colour fastness	Colour staining							Colour fastness		Colour staining	
		SCA <sup>b</sup>	BUC <sup>c</sup>	N <sup>d</sup>	P <sup>e</sup>	A <sup>f</sup>	WW <sup>g</sup>		Dry	Wet	Dry	Wet
WMF	3	4	4-5	5	5	4-5	4	3-4	4	4	5	4
NMF	3-4	4-5	4-5	5	5	4-5	4-5	2	4	3-4	5	5
SMF	2-3	4	4-5	5	5	5	4-5	3	3-4	3-4	5	5
WCF	4	4	4	4-5	4-5	3-4	4	3-4	3-4	3-4	5	5
NCF	3	4-5	4-5	4-5	4-5	4-5	3-4	2	3-4	4	5	4-5
SCF	4	4-5	5	5	5	5	4	3	4	4	5	4-5

<sup>a</sup>Grey scale ratings; <sup>b</sup>Secondary cellulose acetate; <sup>c</sup>Bleached unmercerised cotton; <sup>d</sup>Nylon 66; <sup>e</sup>Polyester; <sup>f</sup>Acrylic; <sup>g</sup>Worsted wool.

**Table 4**

Sample code	L*	a*	b*	C*	h	x	y
WMF	70.42	4.53	19.42	19.94	76.87	0.3656	0.3719
NMF	67.65	6.67	22.72	23.67	73.63	0.3790	0.3783
SMF	74.35	3.76	17.90	18.29	78.14	0.3588	0.3677
WCF	74.03	3.54	21.97	22.25	80.85	0.3672	0.3769
NCF	66.76	6.67	24.11	25.02	74.53	0.3828	0.3820
SCF	67.45	4.91	20.72	21.29	76.68	0.3712	0.3759



**Fig. 1**



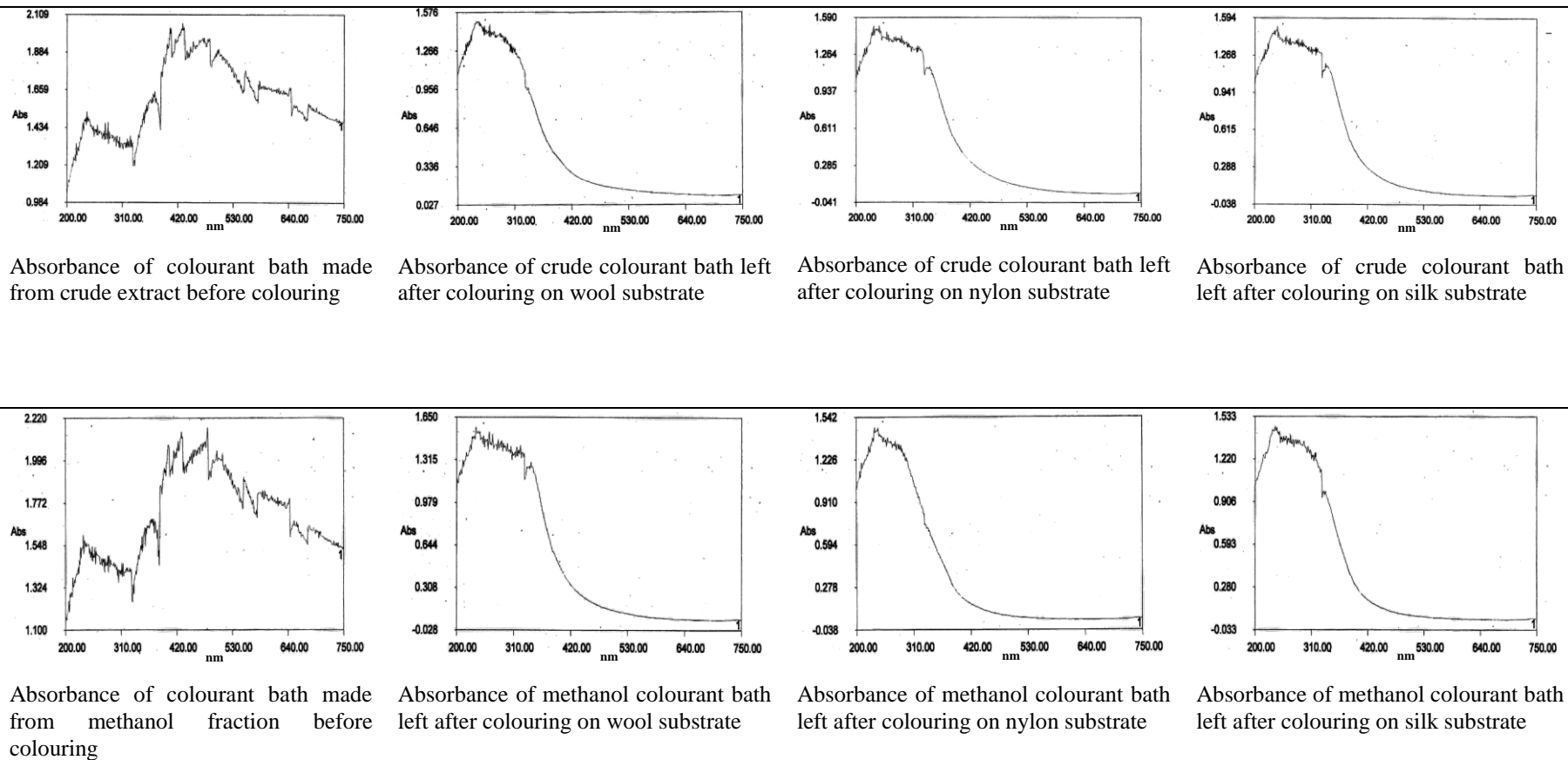


Fig. 2

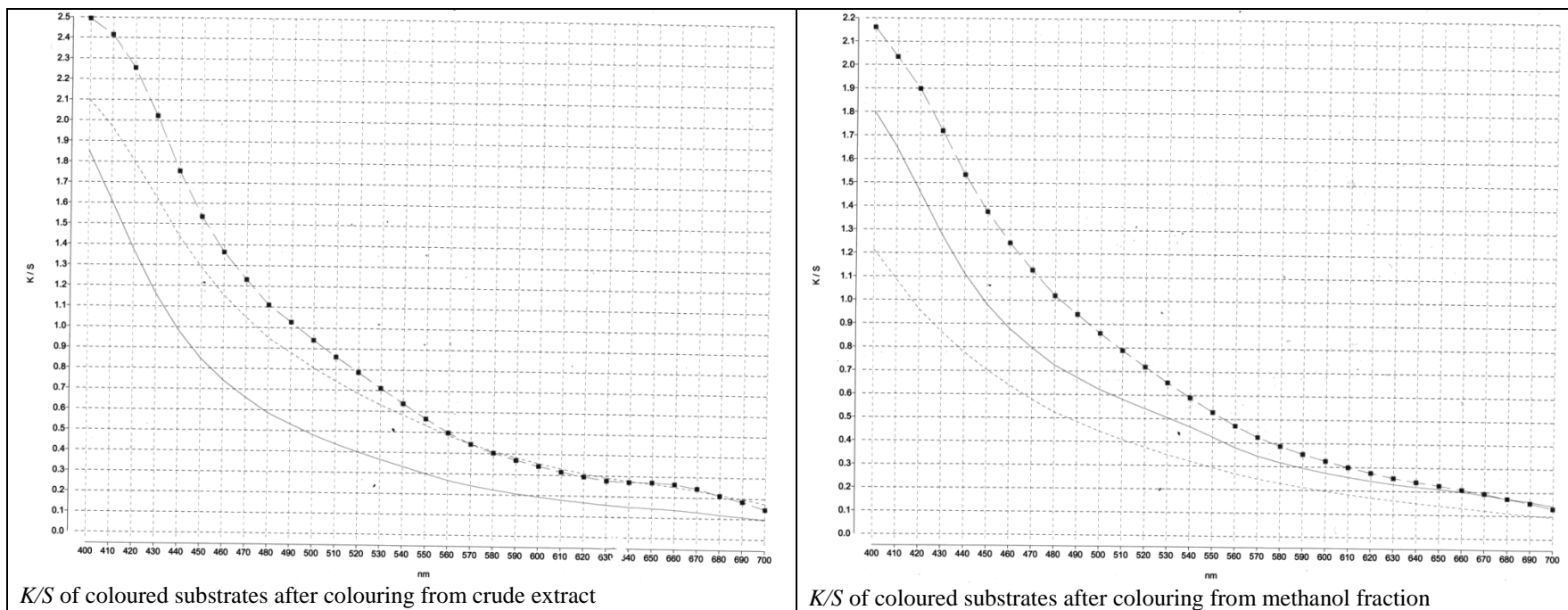
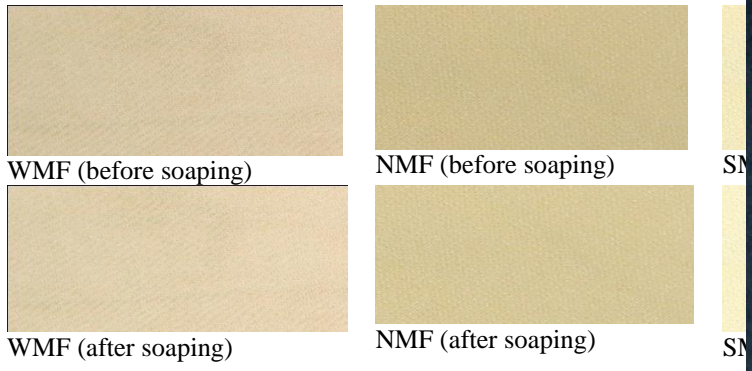
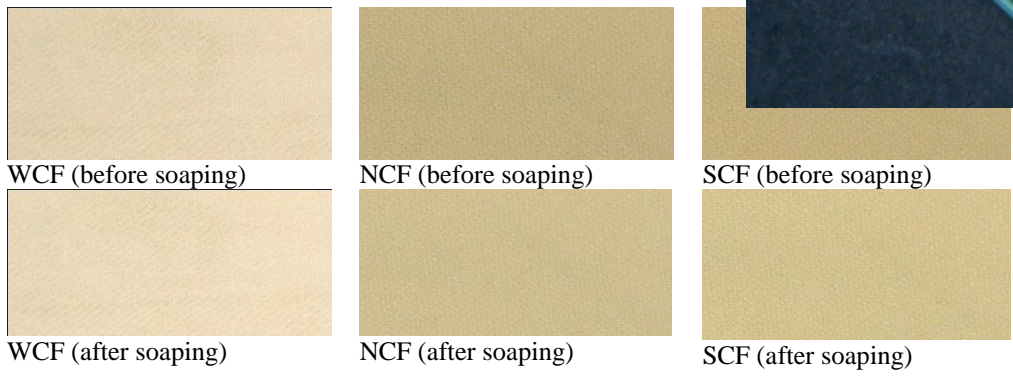


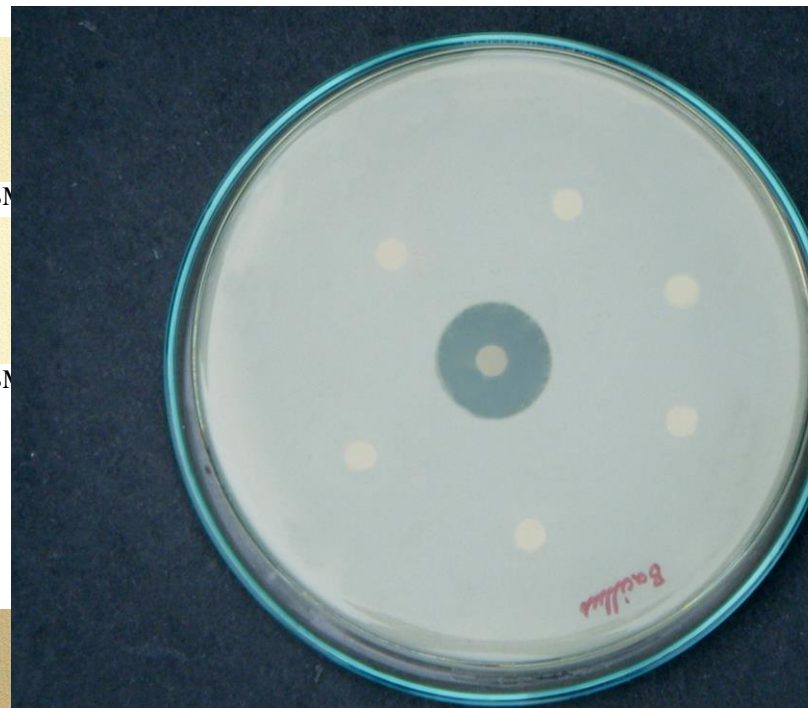
Fig. 3



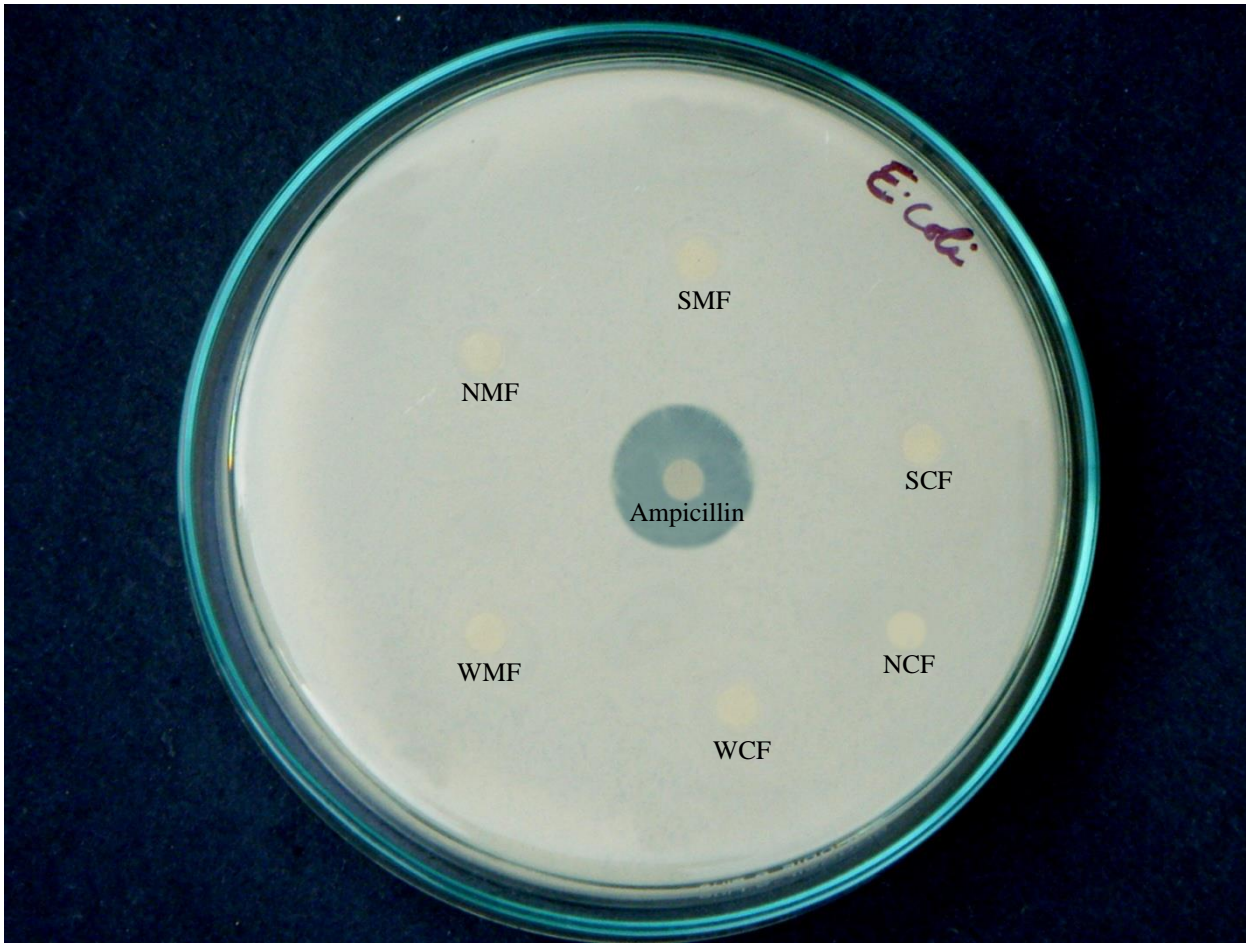
**Fig. 4**



**Fig. 5**



**Fig. 6**



**Fig. 7**

# Estimation of Soil Gas Radon Concentration and the Effective Dose Rate by using SSNTDs

Abd-Elmoniem A. Elzain<sup>1,2</sup>

<sup>1</sup>Department of Physics, University of Kassala, Kassala, Sudan

<sup>2</sup>Department of Physics, College of Science & Arts in Oklat Al-Skoor, Qassim University, Oklat Al-Skoor, Saudi Arabia

**Abstract-** Measurements of radon concentration, and effective dose rate were made for a number of 168 measurements of soil samples in some towns of the Gezira State in the central part of the Sudan. In this survey we used the can technique, containing CR-39, to estimate the radon concentration from the soils of: El-Hosh, Um-Turibat and Medani cities. The results of radon concentrations from soil samples in the selected areas were found to be  $5.50 \pm 0.75 \text{ kBq.m}^{-3}$ ,  $11.05 \pm 4.95 \text{ kBq.m}^{-3}$ ,  $15.10 \pm 1.47 \text{ kBq.m}^{-3}$ , while the effective dose was calculated to be from  $24.51 \pm 3.32 \text{ mSv.y}^{-1}$ ,  $48.22 \pm 10.25 \text{ mSv.y}^{-1}$  and  $67.28 \pm 6.56 \text{ mSv.y}^{-1}$ , for El-Hosh, Um-Turibat and Medani towns, respectively. The results were compared with national and worldwide results.

**Keywords** - Radon, CR-39 detectors, Can technique, Soil.

## I. INTRODUCTION

Radon is a naturally occurring odorless, colorless, tasteless, inert gas which is imperceptible to our sense. It is produced continuously from the decay of naturally occurring radionuclide such as U-238, U-235, Th-232. The isotope  $^{222}\text{Rn}$ , produced from the decay of U-238, is the main source (approximately 55%) of the internal radiation exposure to human life [1].

Gaseous radioactive radon ( $^{222}\text{Rn}$ ), decay product of the radium isotope  $^{226}\text{Ra}$  is present in all types of soil and rock. Radium atoms decays in soil particles, the resulting atoms of radon entering to air filled pores and then transported by diffusion and advection through this space in order to exhale into the atmosphere [2].

Radon concentrations in soil gas within a few meters of the surface of the ground are clearly important in determining radon rates of entry into pore spaces and subsequently into the atmosphere and it's depend on the radium concentration in the bedrock and on the permeability of the soil [3].

There are two main sources for the radon in home's indoor air – the soil and the water supply. Compared to radon entering the homes through water, radon entering homes through the soil is usually much higher. So the radon from soil gas is the main cause of radon problem.

The measurement of  $^{222}\text{Rn}$  concentration in soil gas, in principle, can be used as a method of evaluating the potential for elevated indoor radon concentrations [4].

Radon-prone areas can be identified directly by using indoor measurements or indirectly using radon concentration in the soil, by previous established correlation with the indoor radon concentrations. For example, The United States of America

developed its radon map based on a combination of indoor measurements, geological characteristics, aerial radioactivity, soil permeability and foundation type [5].

Based on the National Academy of Science 1998 BEIR VI Report, the US Environmental Protection Agency estimates that about 21,000 annual lung cancer deaths are radon related. EPA also concluded that the effects of radon and cigarette smoking are synergistic, so that smokers are at higher risk from radon, from which it can be concluded that radon is the second leading cause of lung cancer after smoking [6].

The factors which influence the diffusion of radon from the soil into the air are:

- The uranium and radium concentration in soil and rocks;
- The emanation capacity of the ground;
- The porosity of the rock and soil;
- Barometric pressure gradient between the interfaces;
- Soil moisture and water saturation grade of the medium;
- Other variables [7] .

The aim of the present investigation is to estimate the concentration of radon in the soil-gas and the effective dose rate of three towns in Sudan, see Figure 1.



Figure 1. The map of the study area in, Sudan.



## II. MATERIALS AND METHODS

The can technique [8–10] was employed for the measurement radon concentration and radon effective dose rates in soil samples from three towns in Sudan (Figure 1).

An amount of 4 kg from each sample was collected under the depth 30 cm within 1.5m of the foundations of the dwelling in selected locations, the samples were dried in a temperature controlled furnace (oven) at a temperature  $100 \pm 0.1^\circ\text{C}$  for 24 h to ensure that moisture is completely removed, then the samples were crushed to a fine powder and sieved through a small mesh size to remove the larger grains size and render them more homogenous. About 250 g of each sample was placed in a plastic can of dimensions of 10 cm in height and 7.0 cm in diameter [11]. A passive method (can-technique) using SSNTDs for measurements of radon exhalation rate was used [11-14].

A piece of CR-39 detector of size  $2 \times 2$  cm was fixed on the top of inner surface of the can, in such a way, that it is sensitive surface always facing the sample. The can is sealed air tight with adhesive tape and kept for exposure of about three months. During exposure period, the detector is exposed freely to the emergent radon from the sample in the can so that it could record alpha particles resulting from the decay of radon in the remaining volume of the can. After that, the dosimeters were separated from the sample cup, collected and chemically etched in a 30% solution of KOH, at  $(70.0 \pm 0.10)^\circ\text{C}$  for a period of 9 hours. The resulting  $\alpha$  tracks were counted under an optical microscope of magnification 400X.

The track density was determined and converted into activity concentration  $C_{Rn}$  ( $\text{Bq.m}^{-3}$ ) by using Eq (1) [11, 15-18]:

$$C_{Rn} = \frac{\rho_{Rn}}{K_{Rn}t} \dots\dots\dots(1)$$

where  $\rho$  is the track density (tracks per  $\text{cm}^2$ ),  $t$  is the exposure time and  $K_{Rn}$  is the calibration constant which was determined previously to be:  $K_{Rn} = 3.746 \times 10^{-3}$  tracks. $\text{cm}^{-2}\text{h}^{-1}$  per  $\text{Bq.m}^{-3}$  [11]. The annual effective dose equivalent,  $E_{\text{Eff}}$ , was related to the average radon concentration  $C_{Rn}$  by Eq (2):

$$E_{\text{Eff}} (\text{WLM.y}^{-1}) = \frac{8760 \times n \times F \times C_{Rn}}{170 \times 3700} \dots\dots(2)$$

Where:  $C_{Rn}$  is in  $\text{Bq.m}^{-3}$ ;  $n$  is the fraction of time spent indoors;  $F$  is the equilibrium factor; 8760 is the number of hours per year; and 170 is the number of hours per working month. The values of  $n = 0.8$  and  $F = 0.4$  [3], were used to calculate  $E_{\text{Eff}}$ . For radon exposure, the effective dose equivalents were estimated by using a conversion factor of  $6.3 \text{ mSv.WLM}^{-1}$  [17-19].

## III. RESULTS AND DISCUSSION

This research presents the data of soil gas radon concentration and the effective dose rate from three towns in Sudan through its inner areas.

Table 1. show the radon concentration and effective dose for El-Hosh town in the Gezira State - Sudan. The values of soil gas radon concentration were ranged between 2.11 and  $9.50 \text{ kBq.m}^{-3}$ , with an average of  $5.50 \pm 0.75 \text{ kBq.m}^{-3}$ . The soils of El-Hosh town were noticed to be more moist as compared with other soils in addition to that it some of soils are sandy soils. It was found that radon gas is likely to be emitted from drier soils more than from moist or water saturated soil [21, 22]. It might be useful to recall that, the radon concentration is lower for sandy soils near the saturation state [23].

The values of soil gas radon concentration for El-Hosh town are slightly lower than that found in Saudi Arabia of  $6.71 \text{ kBq.m}^{-3}$  [12], similar to that recorded in Iraq of  $5.74 \text{ kBq.m}^{-3}$  [23], slightly larger than the value founded in Egypt of  $4.35 \text{ kBq.m}^{-3}$  [24] and greater than that found for Kassala, Sudan of  $2.63 \text{ kBq.m}^{-3}$  [25].

For the soil samples taken from Um-Turibat town, as we illustrated in Table 2. the concentration falls within the range of 7.31 and  $12.75 \text{ kBq.m}^{-3}$ , with an average of  $11.05 \pm 4.95 \text{ kBq.m}^{-3}$ . This values of concentrations may be due to that the type of the town which is black clay soil with hard texture. The clay soil contain naturally the rare elements, and this will contribute in razing the probability of increasing radon concentration. Our value survey if compared it would be larger than that found in Rabak town Sudan of  $8.20 \text{ kBq.m}^{-3}$  [18], lower than the average soil gas radon concentration of  $40.1 \text{ kBq.m}^{-3}$  obtained in Slovenia [26].

Table 3. show the range of soil gas radon concentration in Medani town which is from 8.57 to  $19.08 \text{ kBq.m}^{-3}$ , with an average of  $15.10 \pm 1.47 \text{ kBq.m}^{-3}$ . This results may be attributed to the reason of that Medani town, is located along Blue Nile bank, hence its soil is known to being belonged to the river terrace soils. The soil is classified as alluvium soil that transported and deposited by the Blue Nile River as a result of its flowing from the Ethiopian highlands. The alluvium is thought to be derived mainly from igneous crystalline basement complex, but includes some admixture of sedimentary rocks such as marble and quartzite [27]. It was reported that, the soil gas radon concentration in Singa town of Sudan is  $19.9 \text{ kBq.m}^{-3}$ , our result we found for Medani town is much lower than  $75 \text{ kBq.m}^{-3}$  value reported for Austria [28], it is also greater than the recorded values of soil gas radon concentration found in France (Montipellier) with the value of  $2.71 \text{ kBq.m}^{-3}$  [29].

Figure 2. show the average measured values of soil gas radon concentration with respect to each of the towns in our study.

Table 1. Statistical summary of soil gas radon concentration and the effective dose rate for El-Hosh town in Sudan

No	Area	No of samples	Min $\text{kBq.m}^{-3}$	Max $\text{kBq.m}_3$	( $C \pm S.D$ ) $\text{kBq.m}^{-3}$	Effective Dose (mSv per year)
1.	E1	12	2.11	6.48	$4.96 \pm 0.60$	$22.10 \pm 2.67$

2.	E2	12	3.95	9.50	5.48 ± 0.56	24.42 ± 2.50
3.	E3	12	5.79	8.34	6.56 ± 0.84	29.24 ± 3.74
4.	E4	12	3.70	6.27	5.46 ± 0.76	24.33 ± 3.39
5.	E5	12	4.05	6.50	5.04 ± 0.97	22.46 ± 4.32
Overall		60	2.11	9.50	5.50 ± 0.75	24.51 ± 3.32

\*E1, E2, E3, E4, E5 is the sections in El-Hosh town

Table 2. Statistical summary of soil gas radon concentration and the effective dose rate for Um-Turibat town in Sudan

No	Area	No of samples	Min kBq.m <sup>-3</sup>	Max kBq.m <sup>-3</sup>	(C± S.D) kBq.m <sup>-3</sup>	Effective Dose (mSv per year)
1.	U1	12	9.15	12.49	10.82 ± 3.34	48.22 ± 10.25
2.	U2	12	7.31	10.46	8.88 ± 3.44	39.57 ± 9.89
3.	U3	12	12.57	12.75	12.66 ± 6.81	56.42 ± 17.56
4.	U4	12	11.17	12.52	11.84 ± 6.2	52.77 ± 18.05
Overall		48	7.31	12.75	11.05 ± 4.95	48.22 ± 10.25

\*U1, U2, U3, U4 is the sections in El-Managil town

Table 3. Statistical summary of soil gas radon concentration and the effective dose rate for Medani town in Sudan

No	Area	No of samples	Min kBq.m <sup>-3</sup>	Max kBq.m <sup>-3</sup>	(C± S.D) kBq.m <sup>-3</sup>	EFFECTIVE DOSE (mSv per year)
1.	M1	12	12.54	16.00	13.69 ± 1.30	61.01 ± 5.79
2.	M2	12	14.10	19.08	17.24 ± 1.19	76.83 ± 5.30
3.	M3	12	13.69	18.10	15.57 ± 1.58	69.39 ± 7.04
4.	M4	12	13.69	17.06	15.32 ± 1.56	68.28 ± 6.95
5.	M5	12	8.57	16.44	13.66 ± 1.73	60.88 ± 7.71
Overall		60	8.57	19.08	15.10 ± 1.47	67.28 ± 6.56

\*M1, M2, M3, M4, M5 is the sections in Medani town



Figure 2. Soil gas radon concentration with respect to the towns

The mean effective dose rate for soil samples in each town in this study were found to be 24.51 ± 3.32 mSv per year, 48.22 ± 10.25 mSv per year and 67.28 ± 6.56 mSv per year, for E-IHosh, Um-Turibat and Medani

soils respectively. The maximum effective dose rate was found at Medani soils while the minimum effective dose rate was found to be for E-IHosh town.

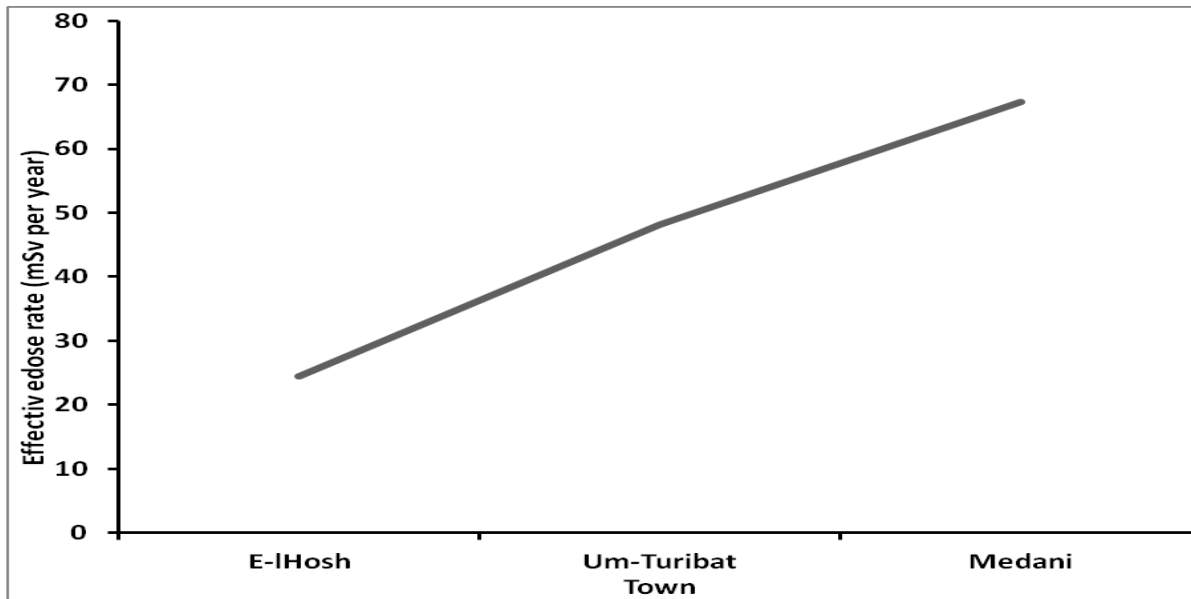


Figure 3. Effective dose rate values for soil samples in El-Hosh, Um-Turibat and Medani towns.

#### IV. CONCLUSION

In this study a total of 168 measurements of soil gas radon concentration measurements have been done in three towns in the central part of the Sudan namely: El-Hosh, Um-Tribat, Medani towns. The study was conducted using previously calibrated passive dosimeters containing CR-39. From the results of our study we conclude that the minimum soil radon concentrations were measured in moist, humid and arable saturated soils. The maximum values of concentration was found in a soil in Medani town, which is annually renewed by re-sedimentations of silt from the Blue Nile river. The computed values of soil gas radon concentrations for all towns were compares with data reported from different geographical regions. The effective dose rate for the soil samples were correlated to the soil gas concentration value measured for each town of this survey.

#### ACKNOWLEDGMENT

I gratefully acknowledge Kassala University and the working staff, for their kind patience and helps with the radon sampling, during the whole period of the research.

#### REFERENCES

[1] ICRP, "International Commission on Radiological Protection (ICRP) 1993 Protection against Radon-222 at homes and at work"; *ICRP Publication 65, Annals of ICRP 23(2)*.  
 [2] UNSCEAR, " Sources and effects of ionizing radiation", *United Nations Scientific Committee on the Effect of Atomic Radiation, Annex A, United Nations, New York, 1988*  
 [3] UNSCEAR, "Sources and effects of ionizing radiation". *Report to General Assembly, with Scientific Annexes. New York: United Nations, 2000*.  
 [4] D. Iskandar, T. Iida, H. Yamazawa, J. Moriizumi, J. Koarashi, K. Yamasoto, K.-Yamasaki, M. Shimo, T. Tsujimoto, S. Ishikawa, M.

Fukuda, H. Kojima, "The transport mechanisms of <sup>222</sup>Rn in soil at Tateishi as an anomaly spot in Japan', *Applied Radiation and Isotopes*, 2005, 63, pp. 401–408.  
 [5] USEPA, "Protocols for Radon and Radon Decay Product Measurement in Homes", United States Environmental Protection Agency, *USEPA Publication 402-R-92-003*. Washington, D.C, 1993.  
 [6] USEPA, "U.S. Environmental Protection Agency 2012 A Citizens Guide to Radon: The Guide to Protecting Yourself and Your Family from Radon", EPA 402/K-12/002, May 2012, www.epa.gov/radon.  
 [7] UNSCEAR, "Sources and effects of ionizing radiation", *United Nations Scientific Committee on the Effects of Atomic Radiation*, New York, 1993.  
 [8] F. Abu-Jarad, "Application of nuclear track etch detector for radon related measurements", *Nucl. Track Radiat. Meas. J.*, 1988, 15, pp. 525-534.  
 [9] H. W. Alter and P. B. Price "Radon detection using track registration material", *US Patent*, 1972, 3, pp. 665, 194 Terradex Corp.  
 [10] D. M. B. Baruah, P. C. Deka, M. Rahman, " Measurement of radium concentration and radon exhalation rate in soil samples using SSNTDs", *The African Review of Physics*, 2013, 8(32), pp. 215 – 218.  
 [11] Abd Elmoniem A. Elzain, "Radon Exhalation Rates from Some Building Materials Used in Sudan" *Indoor and Built Environment published online 5 June 2014*, DOI: 10.1177/1420326X14537285  
 [12] S. M. Farid, "Indoor radon in dwellings of Jeddah city, Saudi Arabia and its correlations with the radium and radon exhalation rates from soil", *Indoor and Built Environment published online June 2014*, DOI: 10.1177/1420326X14536749, 2014.  
 [13] F. A. Mir, S. A. Rather, "Measurement of radioactive nuclides present in soil samples of district Ganderbal of Kashmir Province for radiation safety purposes", *Journal of Radiation Research and Applied Sciences*, 2014, <http://dx.doi.org/10.1016/j.jrras.2014.03.006>.  
 [14] Mohamed Abd-Elzaher, "An Overview on Studying <sup>222</sup>Rn Exhalation Rates using Passive Technique Solid-State Nuclear Track Detectors", *American Journal of Applied Sciences*, 2012, 9 (10), pp. 1653-1659.  
 [15] G. Somogyi "The environmental behavior of radium", *Technical Reports Series No. 310, vol. 1. IAEA*, Vienna, 1990, pp. 229–256.  
 [16] G. Somogyi, A. Hafez, I. Hunyadi and M. Toth–Szilagyi, "Measurement of Exhalation and Diffusion Parameters of Radon in Solids by Plastic Track Detectors", *Nucl. Tracks Radiat. Meas.*, 1986, 12(1-6), pp. 701-704.  
 [17] Abd-Elmoniem A. Elzain, "A Study of Indoor Radon Levels and Radon Effective Dose in Dwellings of Some Cities of Gezira State in Sudan". *Accepted for publication in Nuclear Technology and Radiation Protection, to be published*.  
 [18] Abd-Elmoniem A. Elzain, Y. Sh. Mohammed, Kh. Sh. Mohammed, Sumaia S. M., "Radium and Radon Exhalation Studies in Some Soil

- Samples from Singa and Rabak Towns, Sudan using CR-39", *International Journal of Science and Research (IJSR)*, 2014, 3(11): 632- 637.
- [19] ICRP, "Lung cancer risk from indoor exposures to radon daughters", International Commission on Radiological Protection, *A report of a task group of the ICRP Publication 50*, Oxford: Pergamon Press, 1987.
- [20] K. P. Strong and D. M. Levins, "Effects of Moisture Content on Radon Emanation from uranium Mine and Tailings", *Health phys.*, 1982, **42**, 27-32.
- [21] B. J. Thamer, K. K. Nielson and K. Felthausen, "The Effect of Moisture on Radon Emanation. Open File Report 184-82 Bureau of Mines", *US Department of Interior*, Washington DC, 1981.
- [22] S. Baljinder and H. S. Virk, "Effect of Soil and Sand Moisture Content on Radon Diffusion using Plastic Track Etched Detectors", *Radiat. Meas.*, 1996, **26**(1), 49-50.
- [23] Shafik S. Shafik, Aamir A. Mohammed, "Measurement of Radon and Uranium Concentrations and Background Gamma Rays at the University of Baghdad -Jadiriya Site", *International Journal of Application or Innovation in Engineering & Management (IJAIEM)*, 2013, 2, (5), pp. 455-462.
- [24] K. A. Korany, A. E. Shata, S. F. Hassan, M. S. E. Nagdy, " Depth and Seasonal Variations for the Soil Radon-Gas Concentration Levels at Wadi Naseib Area, Southwestern Sinai, Egypt", *J. Phys. Chem. Biophys.*, 2013, 3, pp. 123, DIO:10.4172/2161-0398.1000123.
- [25] Abd Elmoniem A. Elzain, A. K. Sam, O. M. Mukhtar and M. A. Abbasher " Measurements of Radon Gas Concentration in a Soil at Some Towns in Kassala State.", *Gezira Journal of Engineering & Applied Sciences*, 2009, 4(1), pp.15-42.
- [26] D. Brajnik, U. Miklavžič, and J. Tomšič. Map of natural radioactivity in Slovenia and its correlation to the emanation of radon, *Radiation Protection Dosimetry* 45, 273–276 (1992).
- [27] A.M.A. Kafeel, "*Semi-detailed Soil Survey Report of the Gash-Kassala Area*", Ministry of Agriculture and Irrigation, Soil Survey Administration, Report No. SSA/123, 1982.
- [28] EC, "*An overview of radon surveys in Europe*", European Commission, EUR 21892 EN, 2005, 14–29.
- [29] C. Baixeras, H. Climent, L. I. Font, G. U. Bacmeister, D. Albarracin and M.M. Monnin, "Using Passive Detectors in Soil and Indoors in Tow Mediterranean Locations for Radon Concentration Measurements", *Radiat. Meas.*, 1997, 28(1-6), 713-716.

#### AUTHOR

#### Corresponding Author:



#### **Abd Elmoniem Ahmed Elzain**

(Associate Professor in Applied Radiation Physics and researcher) received the B.Sc. in Physics from Kassala University – Kassala - Sudan (1996) and High Diploma of Physics from Gezira University – Madani – Sudan (1997) and M.Sc. in Physics from Yarmouk University – Erbid – Jordan (2000) and PhD in Applied Radiation

Physics from Kassala University – Kassala – Sudan (2006). He worked at Kassala University since 1996 up to 2010 then from 2010 up to now at Qassim University – Kingdom of Saudi Arabia. (E-mail: Abdelmoniem1@yahoo.com)

# Thermodynamic interactions of l-histidine in aqueous fructose solutions at different temperatures

K.Rajagopal \*, J.Johnson \*\*

\* Department of Physics, Government College of Engineering., Tirunelveli, Tamil Nadu, India.

\*\* Department of Physics Research scholar, M.S. University, Tirunelveli, Tamil Nadu, India.

**Abstract** The present experimental investigation has been carried out in order to explore the possible molecular interionic interactions of l-histidine in aqueous fructose solution at 298.15 K, 303.15K, 308.15K, and 313.15 K. Experimental values of density ( $\rho$ ), ultrasonic speed ( $u$ ), and viscosity ( $\eta$ ) have been measured on the liquid ternary mixtures of water + fructose + l-histidine and relevant molecular interaction parameters such as the apparent molal volume,  $V_{\phi}$ , partial apparent molal volume,  $V_{\phi}^0$  and the slope,  $S_v$ , Hepler's constant,  $\partial^2 V_{\phi}^0 / \partial T^2$ , apparent molal compressibility,  $K_{\phi}$ , partial apparent molal compressibility,  $K_{\phi}^0$  and the slope,  $S_k$ , transfer volume,  $V_{\phi}^0$ , transfer compressibility,  $K_{\phi}^0$ , Jones-Dole coefficient,  $B$ , Jones-Dole coefficient transfer,  $B_{tr}$ , temperature derivative of B-coefficient,  $dB/dT$ , free energy of activation of viscous flow per mole of solvent,  $\Delta\mu_1^{0*}$  and per mole of solute,  $\Delta\mu_2^{0*}$  have been calculated. The results are interpreted in terms of solute-solvent and solute-solute interactions in these systems. It is observed that there exist strong solute-solvent interactions in these systems, which increase with increase in fructose concentration. The thermodynamics of viscous flow has also been discussed.

**Index Terms-** l-histidine, fructose, adiabatic compressibility, apparent molal volume, B-coefficient

## I. INTRODUCTION

Polyhydroxyl compounds play a very important role in stabilizing the native conformations of proteins /enzymes [1-3]. Due to the complex nature of these biological macromolecules the stabilization mechanism of proteins and their unfolding behavior in solution is not well understood yet [4]. In living organisms, interactions of carbohydrates with proteins play a key role in a wide range of biochemical processes. In particular, carbohydrates, located at cell surfaces, are of importance as receptors with regard to the bioactive structures of hormones, enzymes, viruses, antibodies, etc.[5] Thus, the studies on carbohydrate-protein interactions are very important for the field of immunology, biosynthesis, pharmacology, and medicine. As protein molecules are highly complex systems, amino acids are preferred in molecular interaction studies by several authors instead of proteins. However most of these studies available in literature involves amino acids with non-polar, polar, and uncharged R group with aqueous carbohydrate solutions[6]. However the molecular interaction studies of amino acids with positively charge R group with carbohydrates are scarce. For example Nain et al., [6,7], studied and reported the volumetric,

ultrasonic, and viscometric behavior of l-histidine in aqueous glucose solutions, l-histidine in aqueous sucrose solutions, and Zhao et al [8], has reported volumetric and viscometric properties of arginine in aqueous-carbohydrate solutions. In this report the molecular interaction studies of l-histidine in aqueous fructose solution are reported. L- Histidine is a semi essential amino acid, has positively charged R group and essential in growing children, pregnancy and lactating women. Furthermore, Histamine which is formed by decarboxylation of amino acid 'Histidine', that acts as a neurotransmitter, particularly in the hypothalamus. D-fructose is a ketohexose commonly called as fruit sugar, much sweeter than sucrose and more reactive than glucose. Human seminal fluid is rich in fructose and sperms utilize fructose for energy [9]. These considerations led us to undertake the study of L-histidine (with positively charged R group) in aqueous- fructose solutions. As a part of the continuation of our studies of the thermodynamic properties of amino acids in aqueous salt/drug solutions [10-14], in this paper, experimental results of density,  $\rho$ , ultrasonic speed,  $u$ , and viscosity,  $\eta$  have been used to calculate the apparent molal volumes, partial apparent molal volumes and the slope, transfer volumes, Hepler's constant, Jones-Dole coefficient,  $B$ , and temperature derivative of B-coefficient,  $dB/dT$ , the Gibbs free energies of activation of viscous flow per mole of solvent and per mole of solute. These parameters have been used to discuss the solute-solute and solute-solvent interactions in these systems. The thermodynamics of viscous flow has also been discussed.

## II. EXPERIMENTAL

Fructose (99% assay, Merck Ltd. Mumbai), L-histidine (99% assay, Loba Chemie Pvt Ltd), have been used after drying over  $P_2O_5$  in a desiccators for 72 hrs before use. L-histidine of molality (0.02, 0.04, 0.06, 0.08 and 0.1)M have been used as solutes in four different molal concentration of aqueous fructose solvents, which are prepared using doubly distilled deionized water with a conductivity of  $1.5 \times 10^{-4} \Omega^{-1} \cdot m^{-1}$ . The mass measurements have been made using a high precision electronic balance (Model HR 300, Japan) with a precision of  $\pm 0.1$  mg.

The densities of the solutions have been measured using a single stem Pycnometer (Pyrex glass) of bulb capacity of  $13 \times 10^{-3} dm^3$  having graduated stem with  $5 \times 10^{-7} dm^3$ . The reproducibility of density measurements is with  $\pm 2.8 \times 10^{-4} g \cdot cm^{-3}$ . The necessary air buoyancy corrections are also taken care off. The ultrasonic speed has been determined using a ultrasonic interferometer (F-05, Mittal make, India) at a frequency of 2



MHz and the reproducibility of the speed values are within  $\pm 0.03\%$ .

Viscosity has been measured using a suspended level Ubbelohde viscometer with a flow time of 466s for doubly distilled deionized water at 303.15 K. Flow times have been measured using a Racer digital stopwatch having an accuracy of  $\pm 0.01$ s. An average of three sets of flow times readings have been taken for each solution for calculation of viscosity. The overall experimental reproducibility is estimated to be within  $\pm 2 \times 10^{-3}$  m Pa.s. The pycnometer and viscometer filled with test solution have been allowed to stand for about 30 minutes in the thermostatic water bath so as to minimize thermal fluctuations. The temperatures of the solutions have been maintained to an uncertainty of  $\pm 0.01$  K in an electronically controlled thermostatic water bath (Eurotherm, Mittal enterprises, New Delhi). These instruments have been initially standardized using doubly distilled deionized water at different temperatures and the measured values of  $\rho$ ,  $u$  and  $\eta$  are found to be in fairly good agreement with the literature values, thus validating our experimental procedures.

### III. RESULTS AND DISCUSSION

The experimental values of density,  $\rho$ , ultrasonic speed,  $u$ , and viscosity,  $\eta$  of L-histidine solutions in water and in aqueous-fructose solvents as functions of L-histidine concentration and temperature are listed in table 1.

#### 3.1. Apparent molal volume and compressibility

The apparent molal volume,  $V_\phi$  and apparent molal compressibility,  $K_\phi$ , of these solutions have been calculated by using the relations

$$V_\phi = (M/\rho) - 1000(\rho - \rho_0)/m\rho\rho_0 \quad (1)$$

$$K_\phi = \beta_s M/\rho + 1000(\beta_s \rho_0 - \beta_0 \rho)/m\rho\rho_0 \quad (2)$$

where  $m$  is the molal concentration of the solute (l-histidine),  $\rho$  and  $\rho_0$  are the densities of the solution and the solvent (aqueous-fructose), respectively;  $M$  is the molal mass of the solute (l-histidine),  $\beta_s$  and  $\beta_0$  are values of the isentropic compressibility of the solution and the solvent (aqueous-fructose), respectively, calculated using the relation

$$\beta_s = 1/(\rho u^2) \quad (3)$$

The values of  $V_\phi$  and  $K_\phi$  as functions of L-histidine concentration and temperature are calculated. It is observed that, linearities between  $V_\phi/K_\phi$  versus  $m$  is observed in the studied concentration range and at each investigated temperature. Furthermore it is seen that the values of  $V_\phi$  increase with increase in concentration of solute as well as temperature, thereby showing the presence of strong solute-solvent interactions. It is further seen that, the  $K_\phi$  values are negative and increases with increase in concentration and also investigated temperature that may be attributed to the disruption of side group hydration by that of the charged end.

#### 3.2. Partial apparent molal volume and compressibility

The values of partial apparent molal volume,  $V_\phi^0$  and

the slope,  $S_v$ , partial apparent molal compressibility,  $K_\phi^0$  and the slope,  $S_k$  have been obtained using method of linear regression of  $V_\phi$  and  $K_\phi$  vs  $m$  curves from the following relations [15]

$$V_\phi = V_\phi^0 + S_v m \quad (4)$$

$$K_\phi = K_\phi^0 + S_k m \quad (5)$$

where the intercepts,  $V_\phi^0/K_\phi^0$ , by definition are free from solute-solute interactions and therefore provide a measure of solute-solvent interactions, whereas the experimental slope,  $S_v/S_k$  provides information regarding solute-solute interaction. The values of  $V_\phi^0$ ,  $S_v$ ,  $K_\phi^0$  and  $S_k$  along with the standard deviations of linear regression,  $\sigma$  for l-histidine in aqueous-fructose solutions at different temperatures are listed in table 2. A perusal of table 2 reveals that the  $V_\phi^0$  values are positive and  $S_v$  values are negative for l-histidine in aqueous-fructose solutions indicating the presence strong solute-solvent interactions and weak solute-solute interactions in these systems.

The trends observed in  $V_\phi^0$  values may be attributed to their hydration behavior [16-21], which comprises of following interactions in these systems: (a) The terminal groups of zwitterions of amino acids,  $\text{NH}_3^+$ , and  $\text{COO}^-$ , are hydrated in an electrostatic manner whereas, hydration of R group depends on its nature, which may be hydrophilic, hydrophobic, or amphiphilic; (b) electrostriction of  $\text{NH}_3^+$  group is 10 times greater than  $\text{COO}^-$  group; and (c) the overlap of hydration co-spheres of terminal  $\text{NH}_3^+$  and  $\text{COO}^-$  groups and of adjacent groups results in volume change. The  $V_\phi^0$  values increase with increase in concentration of solutes may be related to the reduction in the electrostriction at terminals. The increase in  $V_\phi^0$  values (Table 2) with increase in temperature for l-histidine in aqueous-fructose solutions can be explained by considering the size of primary and secondary solvation layers around the zwitterions [6,7,22,23,24,25].

The values of  $K_\phi^0$  are negative (Table 2) for l-histidine in aqueous fructose solutions, indicating that the water molecules around ionic charged groups of amino acids are less compressible than the water molecules in the bulk solution [26,27]. This further supports the conclusion that there exist strong solute-solvent interactions and weak solute-solute interactions in these systems.

The values of  $K_\phi^0$  are negative and  $S_k$  are positive (Table 2) for l-histidine in aqueous fructose solutions, compliments the existence of strong solute-solvent interactions and weak solute-solute interactions in these systems. Furthermore these results concludes that the hydrophilic-ionic groups and hydrophilic-hydrophilic group interactions between OH groups of fructose with zwitterions of l-histidine dominate in these systems [6]. The values of  $K_\phi^0$  increase with increase in temperature, indicating release of more water molecules from the secondary solvation layer of l-histidine zwitterions into the bulk, thereby, making the solutions more compressible.

#### 3.3. Transfer volume

Partial apparent molal properties of transfer provide qualitative as well as quantitative information regarding solute-solvent interactions without taking into account the effects of solute-solute interactions [28]. The transfer volumes,  $V_{\phi tr}^0$  of l-histidine from water to aqueous-fructose solutions were calculated by using the relation

$$V_{\phi_{tr}}^0 = V_{\phi_{aq-fructose}}^0 + V_{\phi_{water}}^0 \quad (6)$$

where  $V_{\phi_{water}}^0$  is the partial apparent molal volume of l-histidine in water (Table 2). The  $V_{\phi_{tr}}^0$  values for l-histidine from water to aqueous-fructose solutions are included in table 2 and also represented graphically in Figure1. In general, the types of

interactions occurring between l-histidine and fructose can be classified as follows [19,20,29]:

(a) The hydrophilic-ionic interaction between OH groups of fructose and zwitterions of l-histidine.

**TABLE 1: Densities,  $\rho$ , ultrasonic speeds,  $u$ , and viscosities,  $\eta$  of solutions of l-histidine in fructose+water solvents at different temperatures**

m/ mol·kg <sup>-1</sup>	T/K											
	298.15	303.15	308.15	313.15	298.15	303.15	308.15	313.15	298.15	303.15	308.15	313.15
<i>l-Histidine in water</i>												
	$\rho \times 10^{-3} / \text{kg} \cdot \text{m}^{-3}$				$u / \text{m} \cdot \text{s}^{-1}$				$\eta / \text{m} \cdot \text{Pa} \cdot \text{s}$			
0	0.99704	0.99564	0.99402	0.9922	1496.6	1509.4	1520.1	1529.1	0.8905	0.7969	0.719	0.6523
0.02	0.99817	0.99676	0.99513	0.99331	1498.2	1510.9	1521.6	1530.5	0.899	0.8037	0.7236	0.656
0.04	0.9993	0.99789	0.99625	0.99441	1499.7	1512.3	1522.9	1531.7	0.9068	0.8097	0.7284	0.6596
0.06	1.00043	0.99901	0.99737	0.99552	1501.1	1513.6	1524.2	1532.9	0.9143	0.8157	0.7332	0.6633
0.08	1.00157	1.00014	0.99849	0.99664	1502.4	1514.6	1525.4	1533.9	0.9218	0.8217	0.7378	0.6668
0.10	1.0027	1.00127	0.99962	0.99776	1503.8	1515.7	1526.2	1534.7	0.9296	0.8277	0.742	0.6701
<i>l-Histidine in 0.05 M<sub>s</sub>( mol·kg<sup>-1</sup>) aqueous fructose</i>												
0	1.00048	0.99902	0.99737	0.99549	1499.7	1512.5	1523.2	1532.2	0.911	0.8146	0.7344	0.6655
0.02	1.00161	1.00014	0.99848	0.99659	1501.3	1514	1524.7	1533.6	0.9199	0.8217	0.7393	0.6694
0.04	1.00274	1.00126	0.9996	0.9977	1502.8	1515.4	1526	1534.8	0.928	0.8279	0.7442	0.6731
0.06	1.00387	1.00239	1.00073	0.99882	1504.2	1516.6	1527.2	1535.8	0.9361	0.834	0.7491	0.6769
0.08	1.00501	1.00353	1.00185	0.99993	1505.5	1517.6	1528.3	1536.7	0.944	0.8405	0.754	0.6805
0.10	1.00616	1.00466	1.00299	1.00107	1506.8	1518.6	1529.1	1537.5	0.952	0.8469	0.7586	0.6841
<i>l-Histidine in 0.10 M<sub>s</sub>( mol·kg<sup>-1</sup>) aqueous fructose</i>												
0	1.00389	1.00237	1.00069	0.99875	1502.8	1515.6	1526.3	1535.3	0.931	0.8319	0.7655	0.6791
0.02	1.00501	1.00348	1.0018	0.99985	1504.4	1517.1	1527.8	1536.7	0.9402	0.8392	0.7708	0.6832
0.04	1.00613	1.0046	1.00291	1.00096	1505.8	1518.5	1529.1	1537.9	0.9488	0.8456	0.7761	0.687
0.06	1.00726	1.00573	1.00403	1.00207	1507.2	1519.7	1530.3	1538.9	0.957	0.8523	0.7815	0.6909
0.08	1.00839	1.00686	1.00516	1.0032	1508.6	1520.6	1531	1539.7	0.9654	0.8589	0.7866	0.6947
0.10	1.00952	1.00799	1.0063	1.00434	1509.4	1521.6	1532.1	1540.4	0.9737	0.8653	0.7917	0.6985
<i>l-Histidine in 0.15 M<sub>s</sub>( mol·kg<sup>-1</sup>) aqueous fructose</i>												
0	1.00724	1.00563	1.00383	1.00192	1505.8	1518.7	1529.4	1538.4	0.9502	0.8492	0.7655	0.6926
0.02	1.00836	1.00674	1.00493	1.00301	1507.4	1520.2	1530.9	1539.8	0.9597	0.8568	0.7708	0.6968
0.04	1.00948	1.00786	1.00604	1.00412	1508.8	1521.5	1532.2	1541	0.9685	0.8635	0.7761	0.7008
0.06	1.01061	1.00899	1.00717	1.00523	1510.1	1522.7	1533.4	1542	0.9768	0.8703	0.7815	0.7048
0.08	1.01176	1.01012	1.00829	1.00635	1511.3	1523.5	1534.1	1542.7	0.9856	0.8774	0.7866	0.7087
0.10	1.01291	1.01127	1.00943	1.00749	1512.3	1524.2	1535	1543.3	0.9946	0.8839	0.7917	0.7126
<i>l-Histidine in 0.20 M<sub>s</sub>( mol·kg<sup>-1</sup>) aqueous fructose</i>												
0	1.01057	1.0089	1.00704	1.0051	1508.7	1521.8	1532.5	1541.5	0.9694	0.866	0.7799	0.706
0.02	1.01168	1.01	1.00814	1.00619	1510.3	1523.3	1534	1542.9	0.9792	0.8739	0.7854	0.7104
0.04	1.0128	1.01112	1.00925	1.00729	1511.5	1524.7	1535.3	1544.1	0.9883	0.8808	0.7908	0.7145
0.06	1.01392	1.01223	1.01036	1.0084	1512.6	1525.8	1536.4	1545.1	0.9972	0.8878	0.7964	0.7186
0.08	1.01505	1.01336	1.01148	1.00951	1513.7	1526.7	1537.2	1545.9	1.0062	0.895	0.8017	0.7227

0.10 1.01619 1.01449 1.01262 1.01064 1514.3 1527.4 1537.8 1546.1 1.0153 0.9021 0.807 0.7267

m, Molality of l-histidine,  $M_s$  Molality of fructose

**TABLE 2: Partial apparent molal volume,  $V_\phi^0$ , slope,  $S_v$ , transfer volume,  $V_{\phi\ tr}^0$ , partial apparent molar compressibility,  $K_\phi^0$ , slope,  $S_k$ , transfer compressibility,  $K_{\phi\ tr}^0$  and standard deviations of linear regression,  $\sigma$  for l-histidine in aqueous fructose solutions at different temperatures.**

Property	T/K				T/K			
	298.15	303.15	308.15	313.15	298.15	303.15	308.15	313.15
<i>l-Histidine in water</i>								
$10^6 \cdot V_\phi^0 / (\text{m}^3 \cdot \text{mol}^{-1})$	98.900	99.305	99.753	100.336				
	98.860 <sup>a</sup>		99.900 <sup>a</sup>	100.400 <sup>a</sup>				
$10 \cdot \sigma$ for equation 5	0.075	0.057	0.084	0.021				
$10^6 \cdot S_v / (\text{m}^3 \cdot \text{mol}^{-1} \text{ kg}^{-1})$	-7.931	-8.239	-8.397	-9.677				
$10^{15} \cdot K_\phi^0 / (\text{m}^3 \cdot \text{mol}^{-1} \cdot \text{Pa}^{-1})$	-3.013	-2.721	-2.582	-2.224				
	-2.96 <sup>b</sup>		-2.59 <sup>b</sup>					
$\sigma$ for equation 6	0.069	0.075	0.1	0.074				
$10^{18} \cdot S_k / (\text{kg} \cdot \text{m}^3 \cdot \text{N}^{-1} \cdot \text{mol}^{-2} \cdot \text{Pa}^{-1})$	5.857	8.717	8.608	8.706				
<i>l-Histidine in 0.05 / 0.10 M<sub>s</sub> / (mol·kg<sup>-1</sup>) aqueous fructose</i>								
$10^6 \cdot V_\phi^0 / (\text{m}^3 \cdot \text{mol}^{-1})$	99.028	99.423	99.859	100.433	99.155	99.539	99.964	100.529
$10 \cdot \sigma$ for equation 5	0.039	0.049	0.048	0.1	0.046	0.053	0.027	0.05
$10^6 \cdot S_v / (\text{m}^3 \cdot \text{mol}^{-1} \text{ kg}^{-1})$	12.068	-12.16	-13.531	-14.152	10.477	12.666	-14.797	-17.348
$10^6 \cdot V_{\phi\ tr}^0 / (\text{m}^3 \cdot \text{mol}^{-1})$	0.128	0.118	0.106	0.097	0.255	0.234	0.211	0.193
$10^{15} \cdot K_\phi^0 / (\text{m}^3 \cdot \text{mol}^{-1} \cdot \text{Pa}^{-1})$	-2.95	-2.676	-2.551	-2.205	-2.893	-2.633	-2.524	-2.191
$\sigma$ for equation 6	0.04	0.058	0.044	0.06	0.016	0.011	0.014	0.04
$10^{18} \cdot S_k / (\text{kg} \cdot \text{m}^3 \cdot \text{N}^{-1} \cdot \text{mol}^{-2} \cdot \text{Pa}^{-1})$	5.937	9.766	10.03	10.893	8.212	10.687	11.564	12.029
$10^{15} \cdot K_{\phi\ tr}^0 / (\text{m}^5 \text{N}^{-1} \cdot \text{mol}^{-1})$	0.063	0.045	0.031	0.019	0.12	0.088	0.058	0.033
<i>l-Histidine in 0.10 / 0.20 M<sub>s</sub> / (mol·kg<sup>-1</sup>) aqueous fructose</i>								
$10^6 \cdot V_\phi^0 / (\text{m}^3 \cdot \text{mol}^{-1})$	99.28	99.654	100.068	100.624	99.404	99.769	100.169	100.717
$10 \cdot \sigma$ for equation 5	0.035	0.065	0.056	0.035	0.03	0.064	0.046	0.01
$10^6 \cdot S_v / (\text{m}^3 \cdot \text{mol}^{-1} \text{ kg}^{-1})$	16.723	16.573	-15.975	-17.388	14.385	14.625	-17.828	-17.278
$10^6 \cdot V_{\phi\ tr}^0 / (\text{m}^3 \cdot \text{mol}^{-1})$	0.38	0.349	0.315	0.288	0.504	0.464	0.416	0.381
$10^{15} \cdot K_\phi^0 / (\text{m}^3 \cdot \text{mol}^{-1} \cdot \text{Pa}^{-1})$	-2.837	-2.594	-2.499	-2.177	-2.783	-2.561	-2.478	-2.168
$\sigma$ for equation 6	0.06	0.08	0.05	0.11	0.019	0.1	0.05	0.11
$10^{18} \cdot S_k / (\text{kg} \cdot \text{m}^3 \cdot \text{N}^{-1} \cdot \text{mol}^{-2} \cdot \text{Pa}^{-1})$	9.136	12.943	12.483	13.363	14.76	12.761	13.982	14.373
$10^{15} \cdot K_{\phi\ tr}^0 / (\text{m}^5 \text{N}^{-1} \cdot \text{mol}^{-1})$	0.176	0.127	0.083	0.047	0.23	0.16	0.104	0.056

<sup>a</sup> Reference [30]; <sup>b</sup> Reference [31]

(b) Hydrophilic–hydrophilic interaction the OH groups of fructose and NH groups in the side chain of acid l-histidine mediated through hydrogen bonding.

(c) Hydrophilic–hydrophobic interaction between the OH groups of fructose molecule and non-polar (–CH<sub>2</sub>) in the side chain of l-histidine molecule.

(d) Hydrophobic–hydrophobic group interactions between the non-polar groups of fructose and non-polar (–CH<sub>2</sub>) in the side chain of l-histidine molecule.

Generally the values of  $V_{\phi\ tr}^0$  increase due to reduction in the electrostriction at terminals by positive contribution from the

interactions of type (a) and (b), whereas it decreases due to disruption of side group hydration by that of the charged end by negative contribution from the interactions of type (c) and (d) mentioned earlier. The observed positive  $V_{\phi\ tr}^0$  values in this work suggest that the hydrophilic–ionic group and hydrophilic–hydrophilic group interactions dominate in the studied systems. [6,7,32]

### 3.4. Transfer Compressibility

The transfer compressibility of l-histidine from water to aqueous fructose solutions,  $K_{\phi\ tr}^0$  were calculated by the following relation

$$K_{\phi_{tr}}^0 = K_{\phi_{aq.-fructose}}^0 + K_{\phi_{water}}^0 \quad (7)$$

where  $K_{\phi_{water}}^0$  is the partial apparent molal volume of l-histidine in water (Table 2). The  $K_{\phi_{tr}}^0$  values for l-histidine from water to aqueous-fructose solutions are included in Table 2 and also represented graphically in Figure 2. The observed positive  $K_{\phi_{tr}}^0$

values suggest that the hydrophilic– ionic groups and hydrophilic–hydrophilic group interactions dominate in these systems. The  $K_{\phi_{tr}}^0$  values increase with increase in fructose concentration in the solutions (Fig. 2). This may be due to greater

**TABLE 3: Jones–Dole coefficient, B and standard deviations of linear regression,  $\sigma$ , Gibbs energies of activation of viscous flow per mole of solvent,  $\Delta\mu_1^{0*}$ , and per mole of solute,  $\Delta\mu_2^{0*}$  for l-histidine in aqueous fructose solutions at different temperatures.**

Property	T/K				T/K			
	298.15	303.15	308.15	313.15	298.15	303.15	308.15	313.15
<i>l-Histidine in water</i>								
$10^3 \cdot B / (m^3 \cdot mol^{-1})$	0.434	0.382	0.327	0.276				
	0.436 <sup>c</sup>	0.384 <sup>c</sup>	0.329 <sup>c</sup>	0.276 <sup>c</sup>				
$\sigma$ for equation 5	0.021	0.005	0.047	0.03				
$\Delta\mu_1^{0*} / (kJ \cdot mol^{-1})$	9.16	9.04	8.93	8.83				
$\Delta\mu_2^{0*} / (kJ \cdot mol^{-1})$	79.8	73.57	66.7	60.19				
<i>l-Histidine in 0.05 / 0.10 M <math>(mol \cdot kg^{-1})</math> aqueous fructose</i>								
$10^3 \cdot B / (m^3 \cdot mol^{-1})$	0.445	0.391	0.334	0.281	0.452	0.397	0.339	0.285
$\sigma$ for equation 5	0.008	0.003	0.002	0.015	0.015	0.018	0.03	0.007
$\Delta B \cdot 10^3 / (m^3 \cdot mol^{-1})$	0.011	0.009	0.007	0.005	0.018	0.015	0.012	0.009
$\Delta\mu_1^{0*} / (kJ \cdot mol^{-1})$	9.23	9.11	9.00	8.89	9.30	9.17	9.06	8.96
$\Delta\mu_2^{0*} / (kJ \cdot mol^{-1})$	81.05	74.59	67.48	60.73	81.74	75.18	67.98	61.12
<i>l-Histidine in 0.10 / 0.20 M <math>(mol \cdot kg^{-1})</math> aqueous fructose</i>								
$10^3 \cdot B / (m^3 \cdot mol^{-1})$	0.459	0.403	0.344	0.288	0.465	0.408	0.348	0.29
$\sigma$ for equation 5	0.039	0.028	0.021	0.008	0.013	0.024	0.017	0.005
$\Delta B \cdot 10^3 / (m^3 \cdot mol^{-1})$	0.025	0.021	0.017	0.012	0.031	0.026	0.021	0.014
$\Delta\mu_1^{0*} / (kJ \cdot mol^{-1})$	9.36	9.24	9.13	9.02	9.42	9.30	9.19	9.08
$\Delta\mu_2^{0*} / (kJ \cdot mol^{-1})$	82.43	75.77	68.46	61.36	82.97	76.21	68.8	61.46

<sup>c</sup> Reference [6]

hydrophilic–ionic group and hydrophilic– hydrophilic group interactions with increased concentrations of fructose. The observed trends in  $K_{\phi}^0$  and  $K_{\phi_{tr}}^0$  further support the conclusions drawn from  $V_{\phi}^0$  and  $V_{\phi_{tr}}^0$ . The decrease in  $V_{\phi_{tr}}^0$  and  $K_{\phi_{tr}}^0$  values with increase in temperature however indicate that release of water molecules from the secondary solvation layer of l-histidine zwitterions into the bulk, becomes difficult with addition of fructose in the solution due to greater hydrophilic– ionic groups and hydrophilic– hydrophilic group interactions as compared to those in water.

### 3.5. Hepler's constant

Hepler [33] devised a method to account the structure making / breaking properties of solutes in aqueous solutions using the sign of  $(\partial^2 V_{\phi}^0 / \partial T^2)$ . On the basis of this criteria, a structure making solute will exhibit positive  $(\partial^2 V_{\phi}^0 / \partial T^2)$  values and structure breaking solute will show negative  $(\partial^2 V_{\phi}^0 / \partial T^2)$  values [34]. The values of Hepler's constant are given in Table 4. The positive values of  $(\partial^2 V_{\phi}^0 / \partial T^2)_p$  in table 4 indicates that l-histidine act as structure-maker in aqueous-fructose solvents.

### 3.6. Analysis of viscosity data

The viscosity data were analysed by using Jones–Dole [35] equation of the form

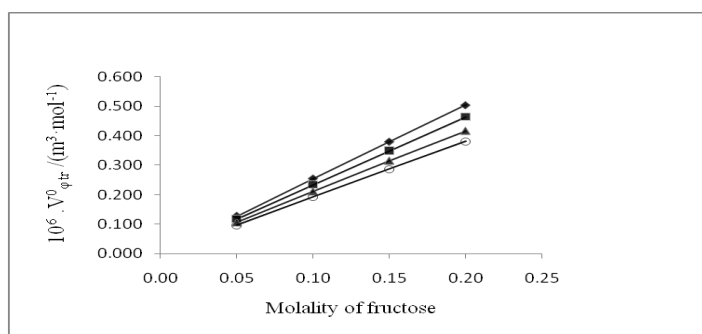
$$\eta_r = \eta / \eta_0 = 1 + B \cdot c \quad (8)$$

where  $\eta_r$  is the relative viscosity of the solution,  $\eta$  and  $\eta_0$  are the viscosities of solution and the solvent (fructose+water), respectively,  $m$  is molality of l-histidine in fructose+water solvent,  $B$  is the Jones–Dole coefficients and  $c$ , is the molarity (calculated from molality data), respectively. The values of  $B$  along with the standard deviations of linear regression,  $\sigma$  are listed in Table 3.  $B$ - Coefficient is a measure of structural modifications induced by the solute–solvent interactions [36,37]. The values  $B$ -coefficients are positive, suggesting weak solute–solute and strong solute–solvent interactions in these solutions. [6]. Furthermore  $B$ -coefficients increase (Fig. 3) with increasing concentration of fructose, the reason may be that the friction increases to prevent water flow at increased fructose concentration. Thus, the values of  $B$ -coefficient support the behaviors of  $V_{\phi}^0$ ,  $K_{\phi}^0$ ,  $S_v$ ,  $S_k$ ,  $V_{\phi_{tr}}^0$  and  $K_{\phi_{tr}}^0$ , which suggest

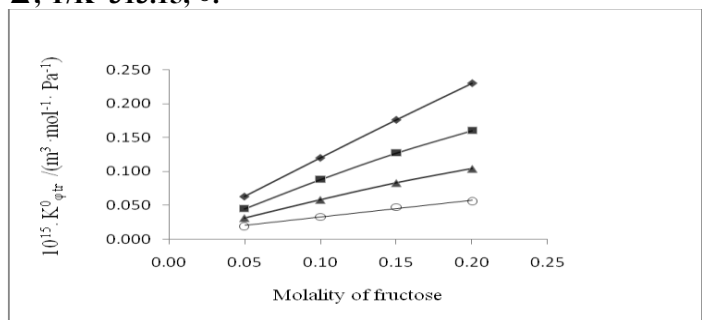
stronger solute–solvent interactions as compared to solute–solute interactions in studied ternary solutions. The temperature derivatives of B-coefficient (dB/dT) have also been calculated

**TABLE 4:Hepler’s constant,  $\partial^2 V_{\phi}^0/\partial T^2$  and temperature derivative of B-coefficient, dB/dT for l-histidine in aqueous Fructose solutions at different temperatures.**

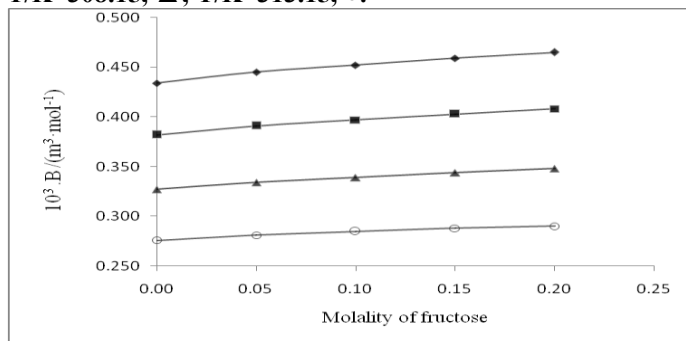
0.05 M <sub>s</sub> / (mol·kg <sup>-1</sup> )	$\partial^2 V_{\phi}^0/\partial T^2$ / (m <sup>6</sup> ·mol <sup>-2</sup> ·k <sup>-2</sup> )	dB/dT / (m <sup>3</sup> ·mol <sup>-1</sup> ·K <sup>-1</sup> )
0	0.00178	-0.0106
0.05	0.00179	-0.011
0.1	0.00181	-0.0112
0.15	0.00182	-0.0114
0.2	0.00183	-0.0117



**Figure 1: Variations of transfer volume,  $V_{\phi}^0$  vs. Molality of fructose,  $M_s$ , for l-histidine in fructose+ water solutions at temperatures, T/K=298.15, 303.15, 308.15, 313.15.**



**Figure 2: Variations of transfer compressibility,  $K_{\phi}^0$  vs. Molality of fructose,  $M_s$ , for l-histidine in fructose+ water solutions at temperatures, T/K=298.15, 303.15, 308.15, 313.15.**



and included in the Table 4. In general, the dB/dT is negative for structure-maker and positive for structure-breaker solutes in

**Figure 3: Variations of Jones-Dole coefficient, B vs. Molality of fructose,  $M_s$ , for l-histidine in fructose+ water solutions at temperatures, T/K=298.15, 303.15, 308.15, 313.15.**

The negative dB/dT values for l-histidine in aqueous-fructose solvents (see table 6) indicate that l-histidine act as structure-maker in aqueous-fructose solvents under study[24,39,40].

### 3.7. Thermodynamics of viscous flow

The viscosity data are used to estimate the free energy of activation per mole of the solvent ( $\Delta\mu_1^{0*}$ ) and solute ( $\Delta\mu_2^{0*}$ ) as suggested by Feakins et al. [41] and Eyring et al.[42] from Eqns. (9),(10) and (11)

$$B = (\bar{V}_1^0 - \bar{V}_2^0) / 1000 + \bar{V}_1^0 / 1000RT (\Delta\mu_2^{0*} - \Delta\mu_1^{0*}) \quad (9)$$

$$\Delta\mu_1^{0*} = RT \ln(\eta_0 \bar{V}_1^0 / hN) \quad (10)$$

Equation (10) can be rearranged as

$$\Delta\mu_2^{0*} = \Delta\mu_1^{0*} + RT / \bar{V}_1^0 [1000B - (\bar{V}_1^0 - \bar{V}_2^0)] \quad (11)$$

It is evident from table 3 that for l-histidine in aqueous-fructose solutions, the  $\Delta\mu_2^{0*}$  values are positive and much larger than those of  $\Delta\mu_1^{0*}$  in aqueous-fructose solvents. This suggests that the process of viscous flow becomes difficult as the temperature and molality increases. Hence, the formation of transition state becomes less favourable. According to Feakins et al.[36,41] and Glasstone et al.[42],  $\Delta\mu_2^{0*} > \Delta\mu_1^{0*}$  for solutes with positive viscosity B-coefficients indicates stronger solute–solvent interactions in the ground state than in the transition state, i.e., the formation of a transition state is accompanied by the rupture and distortion of the intermolecular forces in the solvent structure. Thus, the conclusions drawn from  $\Delta\mu_2^{0*}$  are in agreement with those drawn from the trends of  $V_{\phi}^0$ ,  $V_{\phi}^0$  tr,  $K_{\phi}^0$ ,  $K_{\phi}^0$  tr and B values

## IV. CONCLUSION

The densities,  $\rho$ , ultrasonic speeds,  $u$ , and viscosities,  $\eta$  of solutions of l-histidine in aqueous-fructose solvents of molalities (0.05,0.10,0.15,0.20) $M_s$  were measured at different temperatures. From the experimental data, various parameters, viz.,  $V_{\phi}$ ,  $V_{\phi}^0$ ,  $V_{\phi}^0$  tr,  $K_{\phi}^0$ ,  $K_{\phi}^0$  tr, Jones–Dole coefficient, B and dB/dT were calculated. The results indicate that there exist strong solute–solvent (hydrophilic–ionic group and hydrophilic–hydrophilic group) interactions in these systems, which increase with increase in fructose concentration. It is also observed that l-histidine acts as structure-maker in these aqueous-fructose solvents.



REFERENCES

- [1] J.F. Back, D. Oakenfull, M.B. Smith, *Biochemistry* 18 (1979) 5191–5196.
- [2] H. Uedaira, *Bull. Chem. Soc. Jpn.* 53 (1980) 2451–2455.
- [3] S. Li, W. Sang, R. Lin, *J. Chem. Thermodyn.* 34 (2002) 1761–1768.
- [4] A. Havidt, P. Westh, *J. Solution Chem.* 27 (1998) 340–395.
- [5] D. E. Metzler, *Biochemistry. The Chemical Reactions of Living Cells*, Vol. 1 (Academic Press, New York, 1977).
- [6] A. k. Nain, Renu Pal, Rakesh Kumar Sharma, *J. Chem. Thermodynamics* 43 (2011) 603–612.
- [7] A.K. Nain, Renu Pal, Rakesh Kumar Sharma, *Journal of Molecular Liquids* 165 (2012) 154–160.
- [8] C. Zhao, P. Ma, J. Li, *J. Chem. Thermodyn.* 37 (2005) 37–42
- [9] DR.MN Chatterjea, DR.Rana Shinde, *Text book of medical biochemistry*; Jaypee brothers medical publishers (P) Ltd: New Delhi.2007,Page(27,77,460)
- [10] K. Rajagopal, S. Edwin Gladson, *J. Pure Appl. Ultrasonics* 28 (2006) 87-92.
- [11] K. Rajagopal, S. S. Jayabalakrishnan, *Chinese J. Chem. Eng.* 17 (2009) 796-804.
- [12] K. Rajagopal, S. S. Jayabalakrishnan, *J. Chem. Thermodyn.* 42 (2010) 984-993.
- [13] K. Rajagopal, S. S. Jayabalakrishnan, *Int J Thermophys* (2010) 31:2225–2238.
- [14] K. Rajagopal, S. Edwin Gladson, *J. Chem. Thermodyn.* 43 (2011) 852-867.
- [15] D.O. Masson, *Philosophical Magazine* 8 (1929) 218–223.
- [16] D.P. Kharakoz, *Biophysical Chemistry* 34 (1989) 115–125.
- [17] D.P. Kharakoz, *The Journal of Physical Chemistry* 95 (1991) 5634–5642.
- [18] B. Sinha, V.K. Dakua, M.N. Roy, *Journal of Chemical and Engineering Data* 52 (2007) 1768–1772.
- [19] G.R. Hedwig, H. Hoiland, *The Journal of Chemical Thermodynamics* 25 (1993) 349–354.
- [20] A.K. Mishra, J.C. Ahluwalia, *The Journal of Physical Chemistry* 88 (1984) 86–92.
- [21] J.C. Ahluwalia, C. Cstigny, G. Perron, J. Desnoyers, *Canadian Journal of Chemistry* 55 (1977) 3364–3367.
- [22] R.K. Wadi, P. Ramasami, *Journal of the Chemical Society, Faraday Transactions* 93 (1997) 243–247.
- [23] A. Ali, S. Khan, F. Nabi, *Journal of the Serbian Chemical Society* 72 (2007) 495–512.
- [24] A. Ali, S. Hyder, S. Sabir, D. Chand, A.K. Nain, *J. Chem. Thermodyn.* 38 (2006) 136–143.
- [25] A. Pal, S. Kumar, *J. Chem. Thermodyn.* 37 (2005) 1085–1092.
- [26] H. Rodriguez, A. Soto, A. Arce, M.K. Khoshkbarchi, *Journal of Solution Chemistry* 32 (2003) 53–63.
- [27] A. Soto, A. Arce, M.K. Khoshkbarchi, *Journal of Solution Chemistry* 33 (2003) 11–21.
- [28] T. Banerjee, N. Kishore, *Journal of Solution Chemistry* 34 (2005) 137–153.
- [29] R. Bhat, N. Kishore, J.C. Ahluwalia, *Journal of the Chemical Society, Faraday Transactions* 188 (1988) 2651–2665.
- [30] H. Chao *Biophysical chem.*122(2006) 157-183.
- [31] Yuri Yasuda, Naidu Tochio, Masao Sakurai, and Katsutoshi Nitta. *J.Chem.Eng.Data* 1998,43,205-214.
- [32] C. Zhao, P. Ma, J. Li, *The Journal of Chemical Thermodynamics* 37 (2005) 37–42.
- [33] G. Hepler, *Can. J. Chem.* 47 (1969) 4613–4617.
- [34] B. Sinha, A. Sarkar, P. Roy, D. Brahman, *Int. J. Thermophys.* 32 (2011) 2062–2078.
- [35] G. Jones, M. Dole, *Journal of the American Chemical Society* 51 (1929) 2950–2964.
- [36] D. Feakins, D.J. Freemantle, K.G. Lawrence, *J. Chem. Soc. Faraday Trans.* 70 (1974) 795–806.
- [37] T.C. Bai, G.B. Yan, *Carbohydrate Research* 338 (2003) 2921–2927.
- [38] M. Kaminsky, *Discuss. Faraday Soc.* 24 (1957) 171–179.
- [39] A. Ali, S. Sabir, A.K. Nain, S. Hyder, S. Ahmad, R. Patel, *J. Chem. Soc. Chin.* 54 (2007) 659–666.
- [40] A. Pal, S. Kumar, *J. Mol. Liq.* 109 (2004) 23–32.
- [41] D. Feakins, F. M. Bates, W. E. Waghorne, K.G. Lawrence, *J. Chem. Soc. Faraday, Trans I* 89 (1993) 3381–3388.
- [42] S. Glasstone, K. Laidler, H. Eyring, *The Theory of Rate processes*; McGraw Hill: New York, 194, pp.477.

AUTHORS

**First Author** – K.Rajagopal, Msc,PhD, Government College of Engg.,Tirunelveli, Tamilnadu, India

[krpal25@yahoo.com](mailto:krpal25@yahoo.com)

**Second Author**-J.Johnson,,Msc,MPhil,

Research scholar,M.S.University,TirunelveliTamilnadu,India

[jacobjohn\\_2710@yahoo.com](mailto:jacobjohn_2710@yahoo.com).

**Correspondence Author**- J.Johnson,,Msc,MPhi IResearch

scholar,M.S.University,Tirunelveli, Tamilnadu ,India

[jacobjohn\\_2710@yahoo.com](mailto:jacobjohn_2710@yahoo.com).

MobileNo:+91 9791798275

# Techniques of Surveying and Cadastral Mapping in Vietnam

Truong Quang Hien<sup>1,3</sup>, Ma Cai Xue<sup>2,\*</sup>, He Li Yuan<sup>1,\*</sup>

<sup>1</sup>College of Resources and Environment, Huazhong Agricultural University, China

<sup>2</sup>College of Public Administration, Huazhong Agricultural University, China

<sup>3</sup>Faculty of Geography - Land Administration, Quy Nhon University, Vietnam

**Abstract-** Currently, the surveying and cadastral mapping which serve for the land management is important in Vietnam. Formerly, the measurement of cadastral maps in Vietnam is done mostly manually by measuring optical theodolite and afterwards the map is drawn on the paper. Right now with the development of new technologies, many technological applications are used to measure for the establishment the cadastral map in Vietnam; however, the measure of the cadastral map done by technology electronic total station is the most popular to fit topographical conditions of Vietnam. In this method, the cadastral surveying is primarily use by the total station to measure direct in the field, then we use the specialized softwares such as MicroStation, FAMIS and Pronet to handle the measurement data and edit the map. In this study, cadastral mapping and measurement method for a particular area has found its conclusion. It is Cat Trinh Commune, Phu Cat District, Binh Dinh Province, Vietnam. The final result was the survey network diagram with 425 points including 24 high level cadastral points and the completed cadastral map with the total area of 4865.20 ha. There are 63 sheets in the cadastral map of Cat Trinh Commune which consists of 45 map sheets in scale 1: 2000, 18 map sheets in scale 1: 1000. All of them were stored as the digital files on the computer and the printed papers. Beside the cadastral maps, there are the statistical tables of the land area of each object and the purpose of the land use. This is an important document to help the State agencies manage the land correctly, handy and consistently.

**Index Terms-** *Measuring, Mapping, Cadastral, Cat Trinh Commune, Land Management*

## I. INTRODUCTION

Today, the cadastral map is an important component of the cadastral documents in Vietnam as well as many countries in the world. It serves for the State management unification about the land, and provides the information about the space and the property of the land plot. Cadastral map is also a basis for the planning and the economic and social development; the planning, the land use planning; the land price determination, land lease and land acquisition, etc.

Cat Trinh Commune is located in Southern Phu Cat District, Binh Dinh Province, Vietnam. It's about 50 km from Quy Nhon City (Binh Dinh, Vietnam) and its natural area is 4865.20 ha. Cat Trinh Commune is continuing development in all key aspects economy, politics, society etc. However, the government of the state in regards to the land and the area needs to improve clearance, inspection and land dispute resolution. To apply improvement, we need the cadastral map system with the high accuracy which is based on the land management in the area. Therefore, the measurement and the digital cadastral mapping serving for the state government about the land of the commune is an urgent requirement. [11]

In this article, the process is presented as well as the results of the measurement and cadastral mapping following the total station method in Cat Trinh Commune, Phu Cat District, Binh Dinh Province, Vietnam. The measurement results were closely adjusted by Pronet Software. Afterwards, the accuracy of the measurement results has been evaluated and used Microstation and FAMIS Software in order to edit the cadastral map for this commune. In addition to those results, the article also offers to the results of the land statistology following each land user and the administrative boundary. This is considered to be one of the most important factors to help the management and resolution of the land issues in the commune.

## II. PROCESS AND METHOD

### A. Process

This study was carried out according to process: Collecting documents and data and examining the field and establishing the control network. After founding the control network completely, we had the coordinates of the control points, surveying the field factors in detail (land plot boundary, transportation, hydraulic system, etc.).

The detailed measurement results were put into the computer, and the cadastral map was edited by the specialized softwares such as MicroStation and FAMIS. After that, we checked and compared them with the field then printed the maps. Beside the map sheets of the area studied, there are statistics of the land area of each owner.

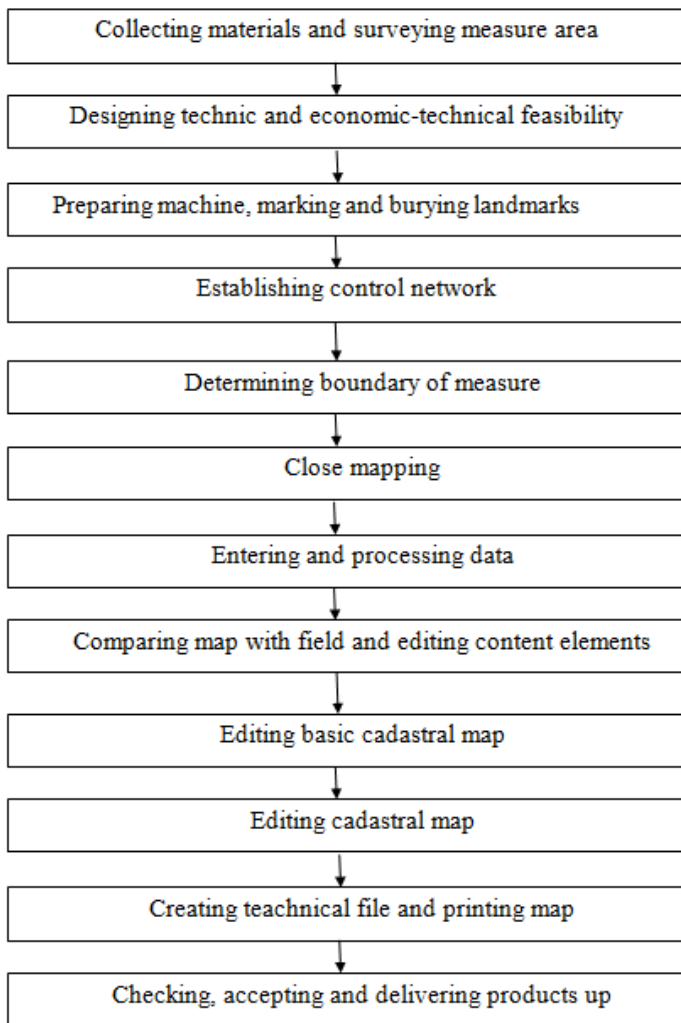


Figure 1. Process of cadastral map Measurement by the total station method in Vietnam [15,19]

### B. Method

We used some of the following study methods:

+ *Surveying and collecting data method:* Collecting data from functional agencies such as People's Committee of Cat Trinh Commune, Department of Natural Resources and Environment of Phu Cat District. They are about high points, existing cadastral points, natural economic - social condition of study areas serving for the topics. And we carried out surveying field in order to know the actual conditions of topography in the measurement area and have a plan for the proper measurement.

+ *Surveying field method:* Using the GTS - 239N total station machine to measure the survey control network, the ground control network was measured by the total station method with 2 times, then we took the average value of the measured results. After measuring and calculating the ground control network completely, we carried out measuring the factors in the field in detail.

+ *Handling data method:* The measured data of ground control network in the field were pretreated and formatted, then we used Pronet software to calculate and adjust the control network. Then the results were considered and evaluated for accuracy. If they are ensure about standards of the request, we

conduct the next steps and have the produce results of precise coordinates of control points.

+ *Mapping methods:* Using Microstation and FAMIS Software which are standard for cadastral mapping, taking measured data into software correctly, then using the commands to edit the cadastral maps for the study area.

## III. RESULTS AND DISCUSSIONS

### A. Generalizing about the research area

Cat Trinh Commune is located in Southern Phu Cat District, Binh Dinh Province, Vietnam. It's about 50 km from Quy Nhon City (Binh Dinh, Vietnam) and its natural area is 4865.20 ha. Its geographic coordinates are from  $108^{\circ}15'14''$  to  $108^{\circ}15'28''$  east longitude and from  $13^{\circ}12'27''$  to  $13^{\circ}16'28''$  north latitude.

The North abuts on Cat Hanh Commune, Cat; the South abuts on Cat Tan Commune, Cat Tai; the East abuts on Cat Thanh Commune, Cat Nhon; the West abuts on Cat Hiep Commune and Ngo May Town.

Cat Trinh Commune is an area which has relatively flat topography, almost the area of the commune is plain and the inhabitants are concentrated. These are favorable conditions for inhabitants' lives as well as the surveying and cadastral mapping.

Beside those advantages, there are some difficulties such as the transportation and irrigation system flooded after the rain. It damaged and affected to the production and inhabitants' lives. [11]

### B. The establishment of the survey network

#### 1. Surveying and collecting data

To serve for measuring the survey control network as well as the cadastral mapping, we has conducted the survey area to assess the level of advantages and disadvantages of the terrain for the mapping process. In general, the terrain is not too complicated and the division level is not much, so it is not too difficult to arrange the survey network.

The documents and data gathered at the land management agencies of district and commune consist of 24 high level cadastral points distributed evenly across the Cat Trinh Commune; the current land use map of commune which was established in 2010 has been edited and added annually. Moreover, there are also some documents of natural conditions, economic and social, the development orientation of the commune in the next years, etc. These are the necessary and useful documents serving for surveying and cadastral mapping process of Cat Trinh Commune.

Table 1: Coordinate of high level cadastral points of Cat Trinh Commune

No.	Point name	Coordinate (m)	
		X	Y
1	TM15	1532871.274	596631.331
2	TM17	1532502.642	596349.431
3	CT20	1532649.047	596026.545
4	CT07	1532834.367	595940.962
5	CT08	1532547.557	595844.127
6	CT09	1533736.898	595110.200
7	CT10	1533566.085	594952.239
8	PC67	1533425.944	595102.821
9	PC30	1533297.443	595260.224
10	CT04	1533174.875	595373.341
11	CT04	1531937.230	597482.725
12	PM02	1531976.494	597392.159
13	PT01	1532040.390	597407.729
14	CT05	1532027.430	597444.242
15	PM01	1532100.901	597437.115
16	CM06	1532062.805	597537.250
17	CT12	1530079.866	597893.234
18	PC53	1530120.121	597919.320
19	PC40	1530212.355	597824.272
20	PC39	1530229.703	597880.668
21	PC66	1531236.421	597901.899
22	PC28	1531234.850	597952.056
23	CT11	1531438.905	597540.914
24	PT02	1530852.421	597532.570

(Source: Department of Natural Resources and Environment of Phu Cat District) [3]

2. Arranging and measuring survey network

Based on the available documents as current state of land use map combined with field survey, we conducted building survey network for Cat Trinh Commune. First, we based on the distribution of the high level cadastral points combined with the condition of the terrain in order to divide the areas for establishing the kinds of measuring survey network. Depending on the real condition of the terrain of each area to arrange the survey network appropriately, the beginning and ending points of the survey network are the cadastral points at level II or higher.

Survey network of the entire Cat Trinh Commune has 425 points including 24 high level cadastral points used for beginning points for the kinds of theodolite traverse. Survey network is built by the total station method with 2 times and each time with 2 halves of measurement, ensuring in accordance with the regulation of Vietnam Ministry of Natural Resources and Environment.

3. Calculate adjustment for theodolite traverse

After measuring the control network, we had specific data including angles and edges in theodolite traverses of each area in the commune. Then we use the Pronet software to conduct the preliminary calculation and detailed adjustment of survey network. The results are expressed as the following illustration.

THEODOLITE TRAVERSE CHECK  
\*\*\*\*\*

1. Route: DHQN2.1\_DHQN2.2\_KV1\_KV2\_KV3\_KV4\_KV5\_KV6\_KV7\_KV8\_DHQN2.1\_DHQN2.2

Route length	[S] = 926,267 (m)	N = 9
Azimuth closure	wb = -185"	w(g/h) = 63.25"
coordinate closure	fx = -0,221 (m)	fy = -0,158 (m)
	fp = 0,271 (m)	fs/[s] = 1/3400

---

Angular error (Ferro)	Mb = 58.502"
Edge error	Ms = 9.041 (cm)
average edge length	s(tb)= 102,849 (m)

Figure 2. Results of calculating survey network preliminary

The entire survey network of Cat Trinh Commune has 425 control points consisting of 24 high level cadastral points known and 401 new established points. Survey network consists of many different theodolite traverses such as traverses closed line and traverses closed loop.

The result of assessment of preliminary calculation for theodolite traverses of Cat Trinh Commune is summarized in the following table:

Table 2: Evaluating results calculated preliminarily of survey network

No.	The technical indicators	Allowed limitation of error	Results	Evaluation
1	Error of closed azimuthal	$\pm 30''\sqrt{n}$	$\pm 5''$ to $\pm 57''$	Qualified
2	Error of closed coordinates	1/3000	1/4800 to 1/3600	Qualified

Through the composite panel and evaluation of results calculated preliminarily of survey network of Cat Trinh Commune, it shows that the results are guaranteed about the technical requirements set out. The calculation errors are much smaller than the allowed errors in the regulation of establishing cadastral map of Vietnam Ministry of Natural Resources and Environment. Therefore, we can proceed to adjust the next steps so as to evaluate the errors of control points in the survey network in more detail.

EVALUATING THE ACCURACY OF THE SURVEY NETWORK

1\_weight number error M = 71.54"

---

2\_weakest point (KV4) mp = 0.121 (m)

---

3\_Length of weakest edge : (KV5 \_ KV6) ms/s = 1/2000

---

4\_Azimuth of weakest edge : (KV6 \_ KV7) ma = 95.19"

ADJUSTMENT VALUE

OR	left	ANGLE between	SYMBOL right	MEA. VALUE o	SO CC m. ph.	SO H.C ('')	ADJU. VALUE o
1	DHQN2.2	KV1	KV2	171 14 45.00	---	43.94	171 15 28.94
2	KV1	KV2	KV3	141 18 25.00	---	1.34	141 19 26.34
3	KV2	KV3	KV4	135 47 10.00	---	58.78	135 48 8.78
4	KV3	KV4	KV5	74 2 25.00	---	26.01	74 2 51.01
5	KV4	KV5	KV6	235 22 55.00	---	5.11	235 23 0.11
6	KV5	KV6	KV7	82 58 30.00	---	-19.79	82 58 10.21
7	KV6	KV7	KV8	102 12 30.00	---	-13.15	102 12 16.85
8	KV7	KV8	DHQN2.1	300 57 30.00	---	13.01	300 57 43.01
9	KV8	DHQN2.1	DHQN2.2	129 20 60.00	---	-1.93	129 20 58.07
10	DHQN2.1	DHQN2.2	KV1	66 41 45.00	---	11.68	66 41 56.68

Figure 3. Evaluating the accuracy of the survey network

After adjusting the survey network of Cat Trinh Commune on Pronet Software, the result was the composite panels of measured data, adjustment value, the coordinate of the points, the kinds of error, etc. The result of evaluating the technical criteria of the survey network of Cat Trinh Commune is summarized in the following table:

Table 3: Evaluating the results of adjustment for survey network of Cat Trinh Commune

No.	The technical indicators	Allowed limitation of error	Results	Evaluation
1	The length of the shortest edge	$\geq 20$ (m)	58.50 (m)	Qualified
2	The length of the longest edge	$\leq 250$ (m)	103.82 (m)	Qualified
3	Error of mean square of traves leg after adjustment	0,020 m	$\leq 0,016$ m	Qualified
4	The smallest angle	$\geq 5^\circ$	45°40'28''	Qualified

The results of calculating the kinds of theodolite traverses of survey network in Cat Trinh Commune with the specification satisfy the than the requirements normative of Vietnam Ministry of Natural Resources and Environment (Table 3). They can be used to edit the survey network for this area and will be as the basis for survey in detail in the future. The results of adjustment are shown in the figure 4:

RESULTS OF CALCULATION FOR THE SURVEY NETWORK  
\*\*\*\*\*

Or di nal	POINT SYMBOL	COORDINATE		LOCATION ERROR		
		X(m)	Y(m)	Mx	My	Mp
1	KV1	1521966.424	604533.868	0.038	0.037	0.053
2	KV2	1521961.798	604445.961	0.061	0.049	0.079
3	KV3	1521881.659	604355.978	0.092	0.050	0.104
4	KV4	1521753.029	604346.726	0.096	0.073	0.121
5	KV5	1521781.202	604481.133	0.057	0.061	0.083
6	KV6	1521730.709	604534.257	0.045	0.071	0.083
7	KV7	1521789.450	604577.746	0.035	0.050	0.061
8	KV8	1521846.808	604527.390	0.029	0.036	0.046

Figure 4. Results of calculation for the survey network by Pronet Software

From the results of the traves points coordinate, we edited the diagram of survey network for the area (Figure 5). The survey network of Cat Trinh Commune consists of 425 points, the traves points are evenly distributed in the commune, the density is ensured to survey in detail.

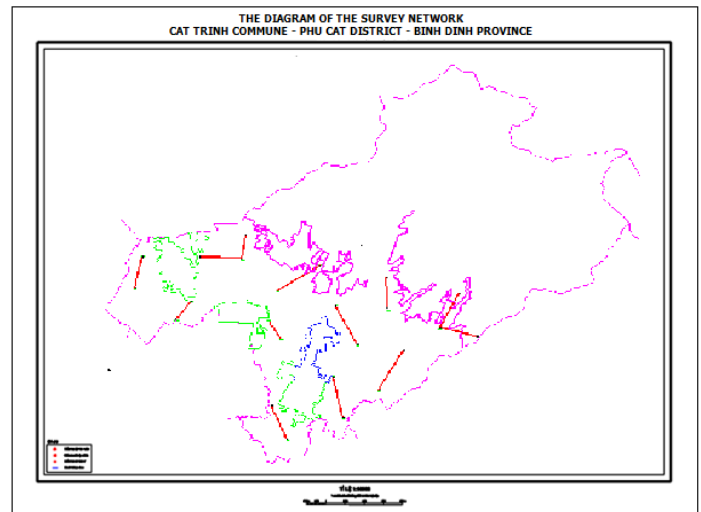


Figure5. The diagram of the survey network of Cat Trinh Commune

### C. Surveying in detail and editing cadastral map for Cat Trinh Commune, Phu Cat District, Binh Dinh Province, Vietnam

Using the GTS - 239N total station machine to measure in detail on the actual factors such as boundaries of the parcel, the terrains, hydraulic system, traffic, etc. The detailed surveying data were processed and used to edit cadastral map by MicroStaion and FAMIS Software.

The implementation process consists of the following basic steps: Running FAMIS Software, creating a new design file; Creating measured value description, editing measured value; Connecting the measuring points according to the diagram; Connecting the database map; Creating zones; Entering the original cadastral information; Drawing labels of plots; Drawing the frame of the map; Creating technical documents of parcels; Printing and delivering products up.

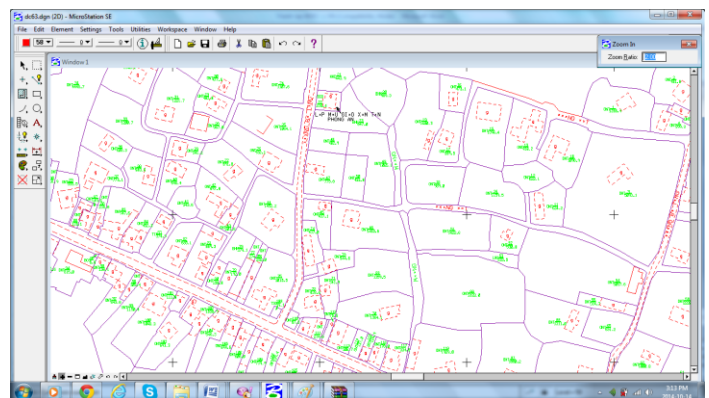


Figure 6. Editing cadastral map by MicroStation Software



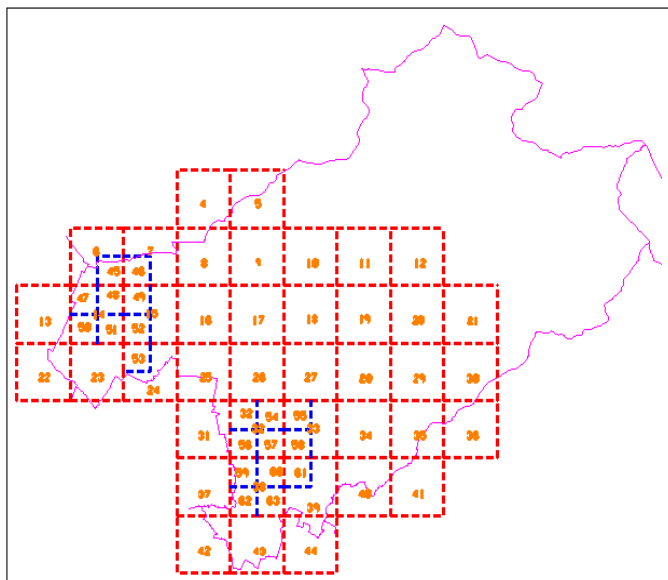


Figure 7. The fragmented diagram of Cadastral Map of Cat Trinh Commune

The cadastral map of Cat Trinh Commune was edited according to the layers of information (level) such as: purpose of land use, hydrology, traffic, numbers of parcel, etc. which help state government to manage land more favorably. MicroStation Software allows us to save over 63 data layers, each layer shows an object of information which we can depend on to display any objects on demand.

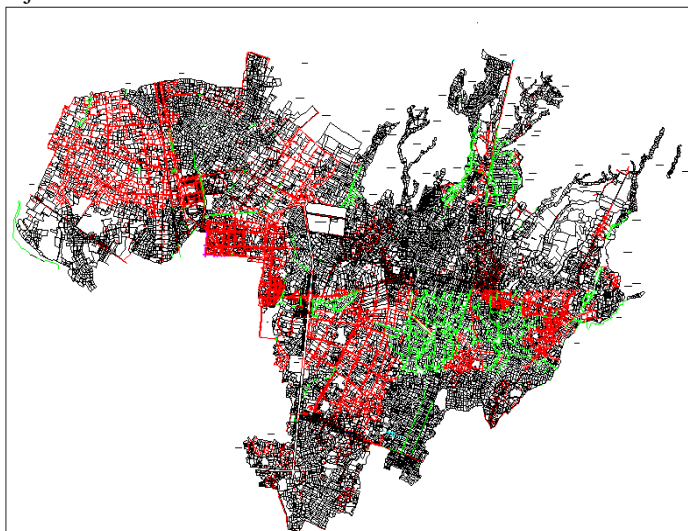


Figure 8. The Cadastral Map in general of Cat Trinh Commune on MicroStation Software

A final technical work before conducting to print map is creating the frame of the map for each cadastral map sheet. With this work, we need to conduct in turn from selecting the landmarks, rate, coordinates of map frame by covering the coordinate fence at the top-left and bottom-right corner of the map sheet, and then proceed to draw the sheet margin.

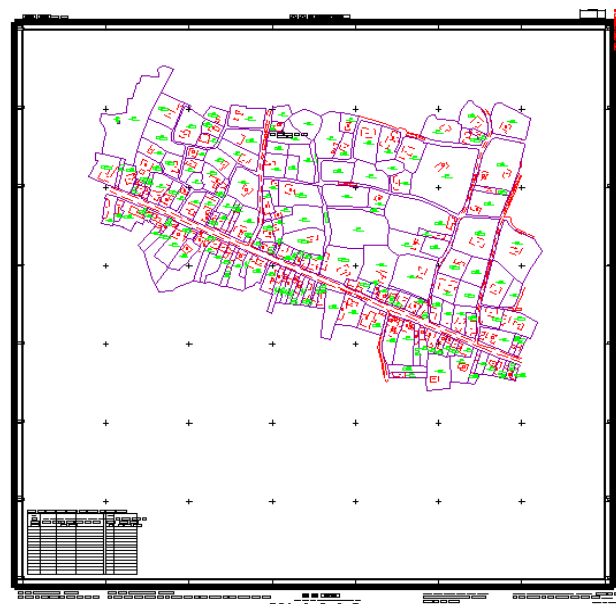


Figure 9. A completed map sheet

After being edited completely, there are 63 map sheets including 45 map sheets in scale 1: 2000, 18 map sheets in scale 1: 1000 of the whole system of cadastral map of Cat Trinh Commune. All of them were edited on 17 layers, each layer stored an information of map sheet. For example, the 10<sup>th</sup> layer shows the boundary of parcels; the thirteenth layer notes the land type, area and number of plots; the 23<sup>rd</sup> layer shows the boundary of traffic, etc.; the 63<sup>rd</sup> layer shows the sheet margin of map. The edition of the information data on each different layer helps the management and using the cadastral map more conveniently through hiding and revealing the layers of information.

No.	Line (From pilot to pilot)	The measured data on the map (m)	The measured in the field (m)	Error (m)	Evaluation
I Line H (from pilot 258 to pilot 246)					
1		200.073	199.809	-0.264	Qualified
2		186.656	186.626	-0.03	Qualified
3		166.118	165.969	-0.149	Qualified
4		146.803	146.842	0.039	Qualified
5		129.073	128.691	-0.382	Qualified
6		104.331	104.272	-0.059	Qualified
7		99.378	99.891	0.513	Qualified
8		54.883	54.703	-0.18	Qualified
9		29.499	29.664	0.165	Qualified
II Line N (from pilot 685 to pilot 515)					
1		231.94	232.39	0.45	Qualified
2		184.89	185.01	0.11	Qualified
3		183.86	183.44	-0.42	Qualified
4		157.02	157.38	0.36	Qualified
5		133.97	133.82	-0.16	Qualified
6		92.18	92.41	0.23	Qualified
7		90.77	90.84	0.06	Qualified
8		53.62	53.59	-0.03	Qualified
9		14.70	14.82	0.12	Qualified
10		11.83	11.88	0.05	Qualified
11		3.22	2.72	-0.50	Qualified

Figure 10. Results of checking the line of land plot

No.	Plot number	Location of land plot edge	Distance of checking (m)	Distance on the map (m)	Error (m)	Evaluation
1	70	South	18.94	18.940	0.00	Qualified
2	71	South	5.17	5.220	-0.05	Qualified
3	72	South	6.05	6.080	-0.03	Qualified
4	73	South	7.94	7.870	0.07	Qualified
5	36	South	23.32	23.380	-0.06	Qualified
6	74	South	10.55	10.600	-0.05	Qualified
7	76	South	16.00	16.060	-0.06	Qualified
8	79	South	5.00	4.960	0.04	Qualified
9	116	North	18.10	18.160	-0.06	Qualified
10	83	South	19.8	19.85	-0.05	Qualified
11	96	West	38.15	38.26	-0.11	Qualified
12	57	West	15.2	15.22	-0.02	Qualified
13	131	North	19.45	19.47	-0.02	Qualified
14	132	North	19.98	19.99	-0.01	Qualified
15	134	North	5	5.06	-0.06	Qualified
16	103	South	23.1	23.19	-0.09	Qualified
17	206	East	19.6	19.58	0.02	Qualified
18	162	North	3.5	3.54	-0.04	Qualified
19	57	West	15.2	15.22	-0.02	Qualified
20	96	West	38.15	38.26	-0.11	Qualified

Figure 11. Results of checking the edges of land plot

The checking in the field consists of the following contents: Comparing the types of land in the field with the map, measuring to check edge map, measuring to check line, measuring random. Through checking and compared the field with the map to assess the accuracy of the map, it shows that the results of measurement ensure the allowed error according to the regulation of Vietnam Ministry of Natural Resources and Environment. Therefore, the cadastral map is built to ensure the precision and it can be used for the management of the State on land (Figure 9, Figure 10).

Table 4: Total of plots, areas, number of owners using land following the administrative boundary of commune according to the current state of cadastral mapping (illustration)

No.	Map sheet number	Total of land plots	Total of owners using land	Area (m <sup>2</sup> )
1	1(548593-5)	81	28	101612.2
2	2(548593-6)	142	24	95813.0
3	3(548596-4)	218	43	294893.7
4	4(548593-8)	387	168	364977.7
5	5(548593-9)	497	164	539830.2
6	6(548596-7)	902	215	930515.6
7	7(548596-8)	583	133	611025.5
8	8(548596-9)	203	57	219055.0
9	9(545593-2)	454	164	391611.0
.....				
63	63(545593-8-b)	138	106	85584.2
<b>Total</b>		<b>17.507</b>	<b>4.337</b>	<b>21.381.723</b>

Through the synthesis, we got the total of land plots of Cat Trinh Commune is 17.507 land plots with 4.337 owners using land (Table 4). The next job was the statistics of land for each owners using land, we obtained the result is the statistic table of land containing the information about each land plots following each owners using land, the area and the purpose of using land, etc. This is an important document to set up cadastral notebook and statistical notebook for each locality; thus, it requires the high precision.

Table 5: Statistics following owners using land (illustration)

Land plots	Area (m <sup>2</sup> )	Land use purposes	Name of owners using land	Address
1	393.5	ONT	Do Thi Kim Cuc	Phong An Village
2	674.4	ONT	Tran Dinh Sang	Phong An Village
3	256.8	ONT	Phan Ngoc Loi	Phong An Village
4	264.2	LUC	Phan Van Dinh	Phong An Village
5	82.4	ONT	Ho Thanh Tung	Phong An Village
6	132.1	ONT	Ho Van Tha	Phong An Village
7	114.1	ONT	Huynh Thi Nghia	Phong An Village
8	1747.2	LUC	Tran Thi Quy	Phong An Village
9	81.7	ONT	Ho Minh Hoa	Phong An Village
10	241.4	ONT	Huynh Thi Ngoc	Phong An Village
.....				
<b>Total</b>				

After completing the measurement, processing data and editing cadastral map by specialized softwares, the final result we got was 63 cadastral map sheets in scale 1: 1000 and 1: 2000 of Cat Trinh Commune, Phu Cat District, Binh Dinh Province. The map sheets were stored as digital files on a computer and print paper, the total of measured land area is 2138,1723 hectares. This is an important document and useful for the management of state about the land for Cat Trinh Commune as well as the land management agencies at higher levels.

#### IV. CONCLUSIONS

This theme outlined the process and the method of establishing cadastral map of Vietnam for an area, namely Cat Trinh Commune, Phu Cat District, Binh Dinh Province. It simultaneously showed the method of assessing the accuracy about the concrete targets of the measurement results. By applying the total station method to measure in the field, using the specialized softwares to process data and edit the control network diagrams, we have founded a survey network system including many diagram types with 425 control points. In which, there are 24 high level cadastral points, the measurement errors are guaranteed about the allowed limits. The results of measuring and editing maps, we had 63 cadastral map sheets which consist of 45 sheets map in scale 1: 2000, 18 sheets map in scale 1:1000. Besides, there is a system of statistical tablets for each map sheet and each land use owner. All of them were stored with two types, those are the paper and digital file type. The products above are important documents which help state government about land to registrate the statistics, resolve the land disputes as well as other work on land more easily.

#### REFERENCES

- [1] A History of the Rectangular Survey System by C. Albert White, 1983, Pub: Washington, D.C. : U.S. Dept. of the Interior, Bureau of Land Management : For sale by Supt. of Docs., U.S. G.P.O.,
- [2] Department of Natural Resources and Environment of Phu Cat District, (2010). Land use status map of Cat Trinh Commune, Phu Cat District, Binh Dinh Province, Vietnam
- [3] Department of Natural Resources and Environment of Phu Cat District. Coordinate of high level cadastral points of Cat Trinh Commune, Phu Cat District, Binh Dinh Province.
- [4] Johnson, Anthony, Solving Stonehenge: The New Key to an Ancient Enigma. (Thames & Hudson, 2008) ISBN 978-0-500-05155-9
- [5] Kahmen, Heribert; Faig, Wolfgang (1988). Surveying. Berlin: de Gruyter. p. 9. ISBN 3-11-008303-5. Retrieved 2014-08-10.
- [6] Lewis, M. J. T. (2001-04-23). Surveying Instruments of Greece and Rome. Cambridge University Press. ISBN 9780521792974. Retrieved 30 August 2012.
- [7] Mahun, Jerry. "Electronic Distance Measurement". Jerrymahun.com. Retrieved 2014-07-20.
- [8] National Cooperative Highway Research Program: Collecting, Processing and Integrating GPS data into GIS, p. 40. Published by Transportation Research Board, 2002 ISBN 0-309-06916-5, ISBN 978-0-309-06916-8
- [9] Nguyen The Phuong (2011). Cadastral mapping method by total station. Teaching Resources for Land Administration majors. Natural Sciences University, Hanoi, Vietnam.
- [10] Nguyen Trong Doi, (2012). User manual cadastral software for mapping work. Teaching Resources for Land Management majors, Quy Nhon University, Vietnam.
- [11] People's Committee of Cat Trinh Commune, Phu Cat District, Binh Dinh Province (2013). Report on the annual about economic - social situation.
- [12] Richards, D., & Hermansen, K. (1995). Use of extrinsic evidence to aid interpretation of deeds. Journal of Surveying Engineering, (121), 178.
- [13] Toni Schenk, Suyoung Seo, Beata Csatho: Accuracy Study of Airborne Laser Scanning Data with Photogrammetry, p. 118
- [14] Truong Quang Hien (2012), Surveying, Teaching Resources for Land Management majors and Construction majors, Quy Nhon University, Vietnam.
- [15] Truong Quang Hien, Nguyen Viet Huy (2012). Cadastral surveying. Teaching Resources for Land Management majors, Quy Nhon University, Vietnam.
- [16] Turner, Gerard L'E. Nineteenth Century Scientific Instruments, Sotheby Publications, 1983, ISBN 0-85667-170-3
- [17] Vietnam Ministry of Natural Resources and Environment. Guide to setting up, edit and management of cadastral record. Circular No. 09/2007/TT-BTNMT, August 2nd 2007.
- [18] Vietnam Ministry of Natural Resources and Environment. Manual testing, appraisal and acceptance of the measuring products and map. Circular No. 05/2009/TT-BTNMT, June 1st 2009.
- [19] Vietnam Ministry of Natural Resources and Environment. Regulation of establishing cadastral map. Decision No. 08/2008/QĐ-BTNMT 10/11/2008.

**Correspondence Author** – Truong Quang Hien, <sup>1</sup>College of Resources and Environment, Huazhong Agricultural University, China; <sup>2</sup>Faculty Of Geography - Land Administration, Quy Nhon University, Vietnam; Email: [truongquanghiendhq@gmail.com](mailto:truongquanghiendhq@gmail.com)

#### AUTHORS

**First Author** – Truong Quang Hien, <sup>1</sup>College of Resources and Environment, Huazhong Agricultural University, China; <sup>2</sup>Faculty Of Geography - Land Administration, Quy Nhon University, Vietnam; Email: [truongquanghiendhq@gmail.com](mailto:truongquanghiendhq@gmail.com)

**Second Author** – Ma Cai Xue, College of Public Administration, Huazhong Agricultural University, China; Email: [macaixue@mail.hzau.edu.cn](mailto:macaixue@mail.hzau.edu.cn)

**Third Author** – He Li Yuan, College of Resources and Environment, Huazhong Agricultural University, China; Email: [heliyuan@mail.hzau.edu.cn](mailto:heliyuan@mail.hzau.edu.cn)

# Power of Android Wearable Technology

Saminath

\*Team Lead Accenture

**Abstract-** Android is an open source mobile device operating system has rapidly recognized in electronics Industry. Android operating system runs in embedded products like smart phones, tablet, set-top box, Android TV, Auto-cars - Android Auto, and wrist watches - Android Wear. Android reaches consumer product beyond its envelop on Multimedia, Mobile Internet Devices, Digital video, Home Entertainment, Automotive, Medical, Networking, Instrumentation and Industrial control. Contemporary industrial product of Android Wearable device connected with human body, it monitors and sync with Mobile device. This technology squeezes cutting-edge features like voice activation, calendar, music, biometrics measurement, email and interacts with other handheld device. This paper presents the Technical Detail of Android wearable, Development and Debug techniques of Android Studio. Development system includes cross compilers, libraries, debuggers, pre-built file system images, and product-specific support libraries.

**Index Terms-** AVD-Android Virtual Device; ADB-Android Debug Bridge.

## I. INTRODUCTION

Android Wear technology is tailored made specifically for Google devices like Watch, Glasses. It comes with a new simplified interface with collection of fitness features. Smart watch has advanced health tracker application, it coaches and remind about workouts, speed, distance, and time information. Biometric tools/sensor in watch integrated with fitness Application. It monitors Heart rate and update average Heart Beat information in regular basis.

The calendar application in the watch shows appointments for the day or upcoming week. Just open and see all your appointments for the day and dismiss it. Timer application is simple and useful for utilize your time bandwidth. Estimate you work, update-in timer, you will get notified by the Application. Google maps shows turn driving direction, sync with card label in phone address book application. Message Application will share the incoming message notification from phone. It shows message content, photo of the person.

You can swipe to reply for the fastidious message. Also you could list the history of the conversation. It supports Voice based message composition and sends it. The same way, you can check your emails and reply by text or voice based message formation. Voice call application is most deserved usage in Android wear device, Call notification is received from phone with pop-up indication. You can decline or attend by swipe the card from the watch. Google search application allows you to find the nearest location around you, with latest update on the

day. Android Wear supports on direct information from your phone. It catches Android phone near to you and gives quick responsive action.

Android Wear technology was engineered to work with wireless devices using Bluetooth. Android wear Google API Client provides high level abstract for Bluetooth communication. Three major API for communications: Nodes API (detects devices in the wearable network), Message API (allows sending messages between Nodes) and Data API (allows data synchronization between Nodes). The Wearable apps installed into wearable device, gives direct access to low-level hardware such as Sensors, Memories, and Audio systems.

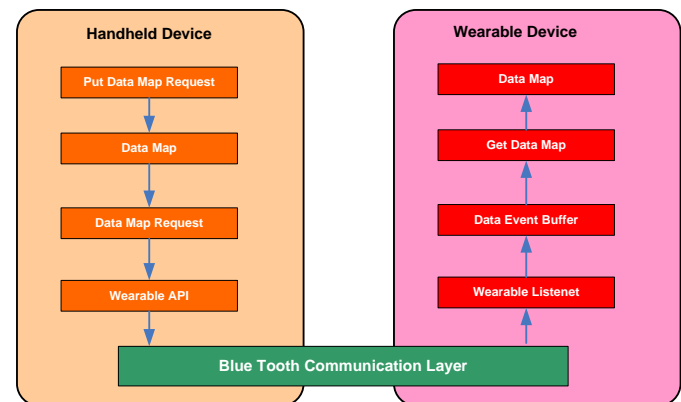


Fig. 1 Communication Layer between Handheld and Wearable Device

Figure-1 explains communication between the Android Handheld device and Wearable Device. Wearable API gets reference from connected mobile device. Data Layer API supports syncing data between handheld and wearable devices. Wearable Listener interface pulling the notifications from paired Android Smartphone's or tablets and display text using Message API. Message API is a one-way communication mechanism that's meant for 'fire-and-forget' tasks". This is just opposed to Wear's Data Layer API. The Google Play service will make this very easy. The communication between two apps over the Bluetooth link that pair two devices.

## II. ANDROID WEARABLE COMPONENT

Android wear component allows user to design UI patterns with New Form factored Android Devices. Below are basic Android wearable component for custom development of Android watches.



**A. Cards:**

Basic UI design of Wearable component is Cards. It has information to users with a respectable look and feel for each UI apps. Card Frame class provides Layout design (Square, Circle) of watch, Size of the Card, Title information, Identification (ID) to each card. Figure-2 shows square watch Card component with Hello message Card Notification.

**B. Notification:**

Context Stream and Cue card are the two ways to share notification between handheld device and Wearable device when it's connected. The context stream is a vertical list of cards, each showing a useful or timely piece of information. Cards in the stream are more than simple notifications. Cards can also be dismissed by swiping left to right, removing them from the stream until the next time the app has useful information to display. Context Stream will display messages without user permission. Cue-card is Voice based notification (EXTRA\_VOICE\_REPLY), added in Remote Input. The Builder class of cue-card allows users by saying, "OK Google" or by selecting list of suggested voice commands, which can also be tapped with Text message. Stacking of Notifications are more than one message is received. The single notification to provide a summary of group messages which will be in stack. The stack of notifications appears as a single card, which users can expand to view the details from each notification separately.

**C. Pages:**

Pages provide additional content information instead of single package information in primary notification. Pages appear immediately to the right of the main notification card. It will be multiple cards for a single notification, a deeper glance with successive cards. It could be a next train departure card, a card showing the weather forecast, scheduled matches etc. Figure-3 and Figure-4 shows the page notification, you can navigate from Left to Right or Top to Bottom.

**D. SYNC Data:**

Google Play services provide several communication channels between handheld device and wearable device. GoogleApiClient is the Main entry point to Google play service, to integrate sync devices. GoogleApiClient\_Builder class provides method that allows you to specify the Google APIs. Data Item is stored in a network, it replicated across all devices in the network. Two functions getData () and setData() will update Item value over the network. Limitation of the Data packet size is 100k.

MessageApi request/response message communication to handheld device. Intern use RPC mechanism for message synchronization. Device should register the Listeners like addListener() and removeListener(), sendMessage() will send the data in bytes format. Asset is another way of transferring the content in BLOB format. It sends a large size of Image and Video's in Bluetooth bandwidth. Wearable Listener Service pays attention of data layer events. It binds and unbinds with required services. On Peer Connectivity triggered when wearable device connected with handheld device. DataListener interface to identify state of the device, whether data items have been changed or deleted.

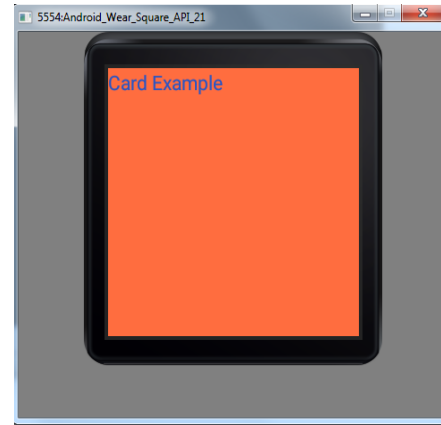


Fig:2 Card Notification

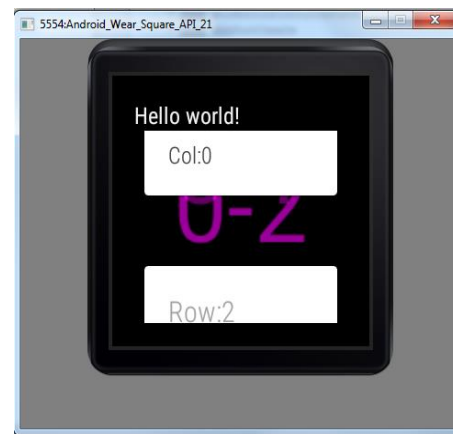


Fig:3 Page Vertical Navigation

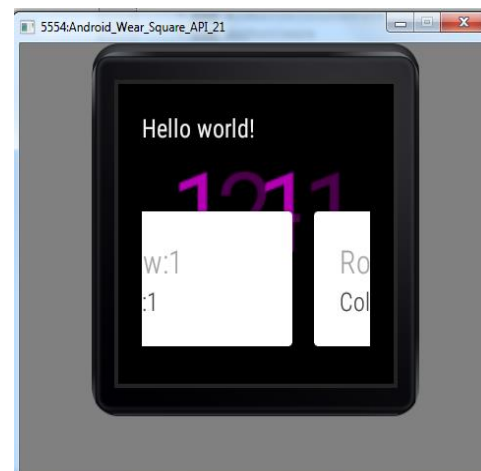


Fig:4 Page Horizontal Nav



III. ANDROID WEARABLE SPECIFICATION

Each Android wear device has different technical specifications. Android wear device make available accurate information at precise time. Various Android Wear partner has different hardware support. Device specification provides various technical feature of the Wearable watch device such as sensors, Battery, shape design. Table-1 explains minimal hardware specification requirement for Android Wear Device.

TABLE I. HARDWARE SPECIFICATION

Android Wear Hardware Functional Specification	
Display Screen	1.63-inch 320 x 320 Special LED configuration
Processor support	<a href="#">Qualcomm</a> Snapdragon with 1.5Ghz
Memory	512MB RAM, 4GB storage
Sensors	Heart-rate monitor, 9-axis accelerometer, GPS sensor, compass, gyroscope
Android OS support	Android 5.0 and implementing API 21 onwards
Screen Face	Round/Square
Battery Support	400mAh, minimum of Complete Day usability
Wireless support	Bluetooth/WiFi
Ports	USB for Debug and Charging

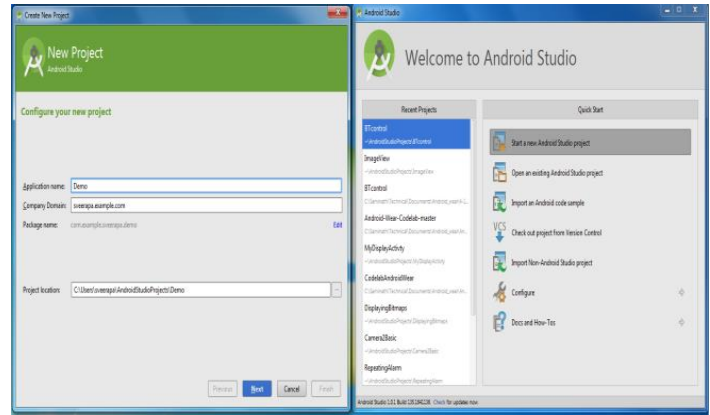


Fig:5 Create Android Wear Project

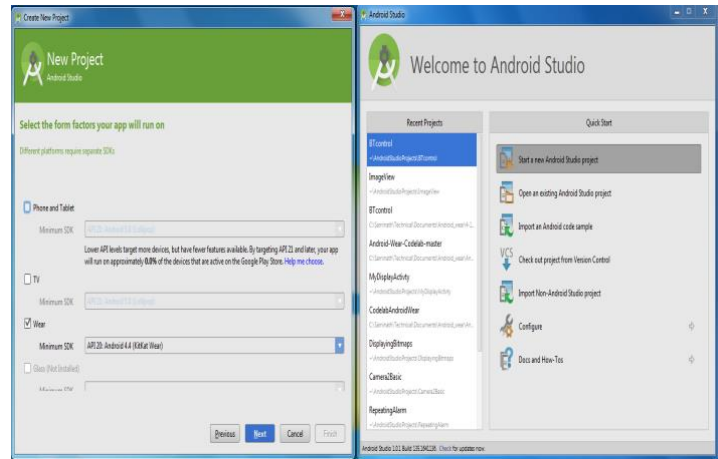


Fig:6 Android SDK Selection

IV. ANDROID BUILD SYSTEM

Android studio is the official IDE for Android wearable device. You can develop application for Android phones, tablets, Android TV, Auto, and Google Glass. To creates a new project with two modules, Mobile and Wear. Figure-5 and Figure-6 explains the creation of new project properties and selection of Platform SDK. New Project follows the Project Wizard instruction with Application Name. Select Wear and select API 20: Android 4.4 (KitKat Wear) under Minimum SDK. The Blank Wear Activity creates a different layout for each of the Android Wear screens: Round layout (Android Wear Round) and Rectangular (Android Wear Square) layout as shown Figure-7. You must create an Android Wear virtual device with the Android Virtual Device Manager, also known as AVD Manager. Launch the AVD Manager from Android Studio and click Create Virtual Device., select wear from the Run/Debug configuration drop-down menu and click the Play button. The activity shows up on the wearable simulator and prints out "Hello Square world!" as shown in Figure-8.

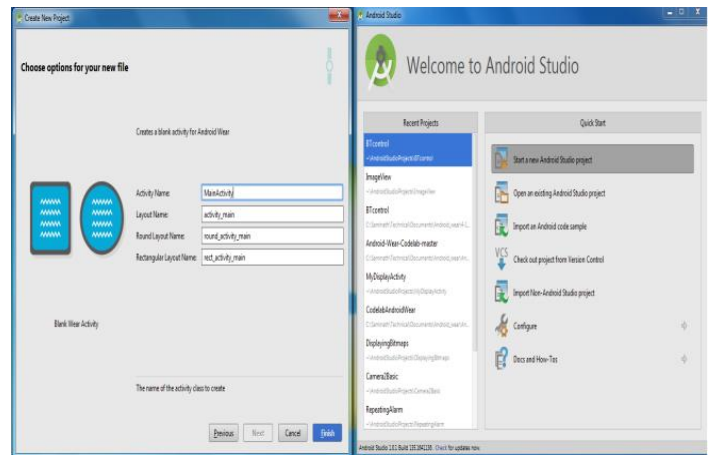


Fig:7 Selection of Android faces

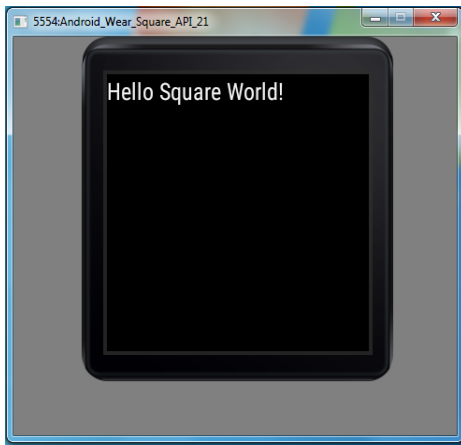


Fig:8 Simulator output

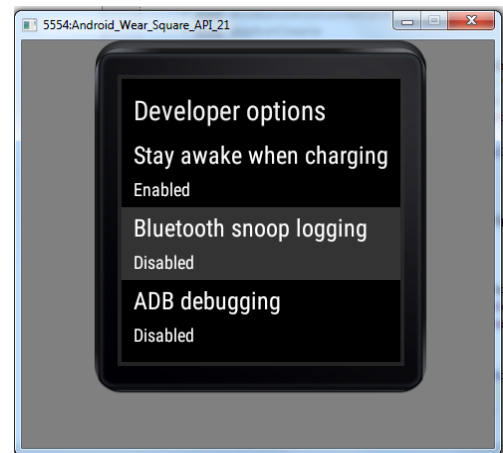


Fig:10 Debug Selection

### V. ANDROID DEBUG SYSTEM

Android Studio enables to debug apps running on the emulator or on Android Wearable device. In Android Wearable device, debug system is disabled as default. It will be enabled by opening Setting and About menu entries. Tab the Build number by 7 times, you can see the Developer option enabled like in Figure-9. Figure-10 explains about the Open the Developer Options, Select the ADB Debugging and Debug over Bluetooth settings. Connect the Wear device with system, via USB. It will ask the RSA key enable, should be always selected. Figure-11 shows the screen info of RSA key configuration.

Another way for debug communication via adb over wireless Bluetooth, this is achieved by forwarding socket. Enable the Bluetooth Debug over Bluetooth in Wearable device. Attach Android phone to computer over USB cable. In Android phone run Android wear companion application, Open Settings, Enable Debugging over Bluetooth

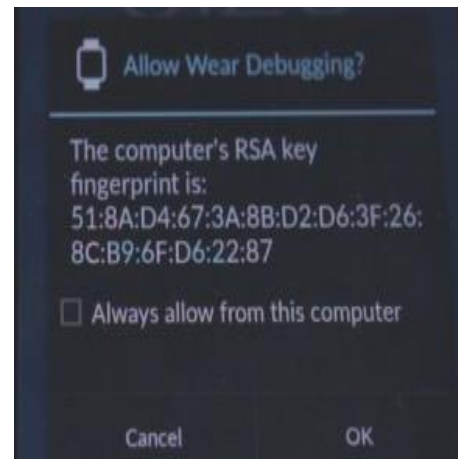


Fig:11 RSA Key configuration

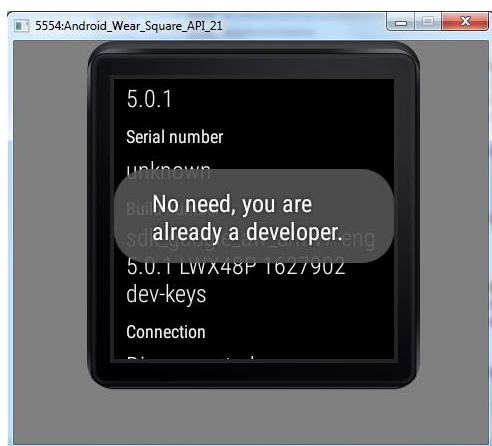


Fig:9 Developer Mode selection

### VI. CONCLUSION

Android Wear smartwatches allows to access and control right from their wrists. Your Identity will be reflected in your watch. It enlarges number of Android Application development and set their competency in android wear product. Personal Health segment (PHS) has scope on evolving quickly with wear devices. Your medical records can be shared to Centers of Disease Control (CDC), Health Insurance has quick estimate your individual fitness records and ease on policy Accountability. Another Major market on Home automation and security domain. You can monitor from wrist watch around you. Security IP cameras configured to watch, it allows the user to observe activity around a house or business right from a Wear device. The intercom system allows communication via a microphone and loud speaker between different places. This is open source Android project, cost of the Implementation is very low and effective for Target product development. As per the WDS (Wireless Device Strategies) research service says about the Automobile and controls. Connect2Car application has control and entertainment feature from wrist.

#### REFERENCES

- [1] <http://www.drdoobbs.com/architecture-and-design/the-wearable-computing-revolution-begins/240169279>
- [2] <https://developer.android.com/design/wear/watchfaces.html>
- [3] <https://developer.android.com/training/wearables/apps/packaging.html>
- [4] <http://www.makeuseof.com/tag/what-operating-systems-do-wearable-devices-run-on/>
- [5] <http://www.androidpolice.com/2014/07/05/how-to-android-wear-enable-debugging-take-screenshots-unlock-the-bootloader-and-root-the-lg-g-watch/>
- [6] Android Wear Basic by “Pedro Lobito”
- [7] <http://www.wearabletechnology-news.com/news/2014/oct/01/deep-dive-getting-started-android-wear/>
- [8] <http://www.techradar.com/news/portable-devices/google-android-wear-what-you-need-to-know-1235025/3>
- [9] Android Wear Document Release 1.0 by “Micheal Hahn”
- [10] <http://observationdeck.io9.com/android-wear-review-the-os-itself-1637794213>

#### AUTHORS

**First Author** –Saminath, M.E, Accenture,Bangalore and s.x.veerapandian@accenture.com.

# Comparison of Paravertebral Block with Spinal Anaesthesia in Unilateral Inguinal Hernia Repair

Dr. Aswin.A.B<sup>1</sup>, Dr. Suresh.Y.V<sup>2</sup>

\* Post graduate, Department of Anaesthesiology, Kasturba medical college, Manipal University, Mangalore, Karnataka

\*\* Associate professor, Department of Anaesthesiology, Kasturba medical college, Manipal University, Mangalore, Karnataka

**Abstract- Aim:** The aim of our study was to evaluate the efficacy of Paravertebral block in unilateral inguinal hernia repair comparing with spinal anaesthesia with respect to post operative analgesia, ambulation, perioperative and postoperative complications.

Paravertebral block can be used as an alternative to spinal anaesthesia in unilateral inguinal hernia repair. It offers better hemodynamic control, prolonged post operative analgesia and early ambulation compared to spinal anaesthesia.

**METHODS:** Total of 60 males patients of ASA 1, 2 with age 18-65 years were taken up for study. They were randomly assigned into two groups group P and group S with 30 in each group. Paravertebral block was given as 2 segment block at T10 and L1. Both groups received propofol infusion titrated to light sleep.

**RESULTS:** The time of first rescue post operative analgesia was taken as primary outcome and was 348±39 min. in group P and 207±26 min. in group S ( $p < 0.001$ ). Time of ambulation was 249±20 min. in group P and 371±18 min. in group S ( $p < 0.001$ ). Incidence of urinary catheterization was higher in group S ( $p < 0.05$ ). No Patients in group P were catheterized. No patients of group S bypassed recovery room

**CONCLUSION:** It can be concluded that paravertebral block is efficacious to spinal anaesthesia in unilateral inguinal hernia repair with respect to prolonged analgesia, early ambulation and decreasing complications seen with spinal anaesthesia.

**Index Terms-** Thoraco-lumbar Paravertebral block, Spinal anaesthesia, Inguinal hernia Repair, post operative analgesia, Visual acuity scale, Early ambulation

## I. INTRODUCTION

Paravertebral block is used as anesthesia for surgical procedures like breast surgery, thoracotomy, inguinal hernia repair, renal surgery predominantly in unilateral procedures as well in chest trauma (rib fracture) for analgesia. Paravertebral block can also be used for surgical anesthesia in patients with serious co-morbidities like chest infection, bronchial asthma etc who could not tolerate general anesthesia or neuraxial blocks.<sup>1</sup> In case of inguinal hernia surgery which is predominantly done under central-neuraxial anesthesia, Paravertebral block which has segmental block offers an attractive alternative in terms of better hemodynamic control, prolonged post-operative analgesia and in decreasing complications like post operative nausea vomiting (PONV), urinary retention and delayed ambulation<sup>2</sup>.

Paravertebral block is also been used in ambulatory surgery unit for inguinal herniorrhaphy and in outpatient procedures<sup>3</sup>.

## II. METHODS

The study was an experimental double blinded randomized controlled study. After obtaining Institutional ethics committee's approval 60 male patients of age group 18 to 65 years with ASA physical status 1 and 2 scheduled for elective unilateral hernia repair were selected for study. The patients were explained about the procedure and its complications, VAS scoring during the pre operative examination. The exclusion criteria were patient's refusal, significant cardiovascular, respiratory, hepatic, diabetes, metabolic diseases, morbid obesity, coagulation disorders, mental dysfunction and allergy to local anesthetics. Patients were randomly assigned to two groups – P and S, according to a sealed envelope method to receive one of the following two anaesthetic techniques – Paravertebral block (PVB) or Spinal anaesthesia (SA), respectively

Para vertebral block was given as 2 segment block, T10, L1<sup>4</sup>. The patient was positioned in the sitting position. The back should assume kyphosis similar to the position required for neuraxial anesthesia. The patient's feet were rested on a stool to allow for a greater comfort and degree of kyphosis. This increases the distance between the adjacent transverse processes and facilitates advancement of the needle beyond the contact with the transverse process. With aseptic precautions, a point 3 cm. lateral to the cephalad aspect of spinous processes of T10 and L1 was marked. Skin was infiltrated with 2% lignocaine at this point. A 23 G Quincke (QBC) needle was inserted perpendicular to the skin at this point to contact transverse process. The needle was then withdrawn a bit and walked off the transverse process by redirecting the needle to the cephalad or caudad to 1 cm. After negative aspiration of blood and cerebrospinal fluid (CSF), with the help of extension line connected to Quincke (QBC) needle 15 ml of bupivacaine (0.5%) at T10 and 5 ml of bupivacaine (0.5%) at L1 was injected. Patients were repositioned to supine after the procedure.

The patients of group S were preloaded with 15ml/kg of IV fluid. Under strict aseptic precautions L3 – L4 level after skin infiltration with 2 % lignocaine sub arachnoid space was approached using 25 G QBC needle. 12.5 mg of 0.5% Bupivacaine (H) injected. After the procedure patients were shifted to supine position. Level of sensory block was assessed by pinprick and level slightly higher than T 10 would be achieved. Motor blockade was assessed by Modified Bromage score<sup>5</sup> 0–3 (0- full flexion of knees and feet; 1- just able to flex

knees, full flexion of feet; 2 - unable to flex knees, but some flexion of feet possible; 3-unable to move legs or feet). Any episode of hypotension [mean arterial pressure (MAP) <70mmHg] was managed with rush of I.V fluids and 6mg I.V mephentermine and repeated if necessary. Any episode of bradycardia (heart rate < 45/min) was treated with Injection Atropine 0.6 mg I.V.

During surgery, patients of both the groups received an I.V infusion of propofol titratable to light sleep with easy arousability. Total dose of propofol used was noted.

After surgery, patients were transferred either to the recovery room under strict monitoring or directly to the ward, if the patients met the criteria for transfer adequately. Patients were evaluated using a modified Aldrete score by the recovery room anaesthetist who makes decision regarding the patient's eligibility to bypass recovery going directly to the ward. It includes ability to move extremities, respiratory effort, consciousness, blood pressure and oxygen saturation. Patients were bypassed recovery room only with modified Aldrete score of 9 or more<sup>6</sup>.

Time to first rescue postoperative analgesia, time to ambulation, total analgesia consumption in first 24 hours and incidence of side effects were measured. Pain was assessed using visual acuity score VAS (0 to 10; 0- no pain 10 – worst pain). All the patients were explained before surgery regarding VAS score. Any time VAS score > 4 were treated with rescue analgesia of injection Tramadol 50 mg. iv repeated if necessary. Inj. Ondansetron 4 mg. iv was given as rescue anti-emetics. Any patient, if not passed urine for more than 3 hours or complaining of urinary retention, was catheterized. Any other complaints and side effects were noted.

### III. STATISTICS

Statistical package SPSS-vers.11.5 /17.0 was used to do analysis. P value < 0.05 was considered as significant.

### IV. RESULTS

The two groups were statistically comparable with respect to age, weight, ASA scores, preoperative vital parameters, SBP, DBP, SPO2. (Table 1)

Intra operatively incidence of hypotension and use of vasopressor was high in group S, 15 patients( 50%) as compared to no such incidence in group P. Total consumption of propofol was higher in group P compared to group S ( p < 0.001) (Table 2)

The VAS score was highest at 6 hours for group P (p < 0.001) and 4 hours for group S(p<0.001) and was significant at 4, 6 hours. At 12, 24 hours there was no significant difference (Graph 1). The rescue analgesic Tramadol in boluses of 50mg IV was used if VAS score > 4 and repeated every 15 min until pain was relieved (VAS < 3). Time to the first dose of analgesic was significantly different in the two groups (P< 0.0001) and total analgesic consumption in 24 hours also was significant in two groups (p<0.001) (Table 3).

The time of ambulation was also significant between two groups and was higher in group S (P< 0.001). 4 patients(13.3%) experienced post operative nausea vomiting (PONV) in group S and 1 patient(3.3%) in group P which was statistically not significant (p= 0.161). 5 patients in group S were catheterized in post operative period due to urinary retention whereas no patients were catheterized in group P(p= 0.05 significant). All patients in group P bypassed recovery room.(Table 3)

**TABLE 1**  
**Demographic profile and baseline vital parameters for patients undergoing inguinal hernia repair**

PARAMETERS	GROUP P(n =30)	GROUP S( n =30)
AGE ( in years)	49±8.67	47±12.10
WEIGHT (in kg.)	60.08±9.34	58.47±9.67
ASA ½ (%)	18/12(60/40)	20/10(66.7/33.3)
PRE OP SBP ( mm of Hg.)	136.84±15.24	133.60±14.08
PRE OP DBP ( mm of Hg.)	82.84±6.839	81.66±7.63
PRE OP SPO2 (%)	99.38 ±0.637	99.06±0.828

All tests are Fischer's exact T test except ASA for which Pearson's chi square test was used. All values are presented as mean±SD except for ASA which is presented as number of patients (%).

Group P Paravertebral group, Group S spinal group, SBP Systolic Blood pressure, DBP diastolic blood pressure, SPO2 oxygen saturation, Pre op pre operative.

**TABLE 2**  
**Intra-operative drug requirement in both groups P and S**

PARAMETERS	GROUP P	GROUP S
Use of Mephentermine (n & %)	0 (0%)	15(50%)*
Propofol dosage (mg.)	166±19	66±10*

\*significant (p<0.05)



For use of Mephentermine Pearson's chi square test was used results presented as no. of patients; For propofol dosage Fischer's exact T test was used and results described as mean  $\pm$  SD.

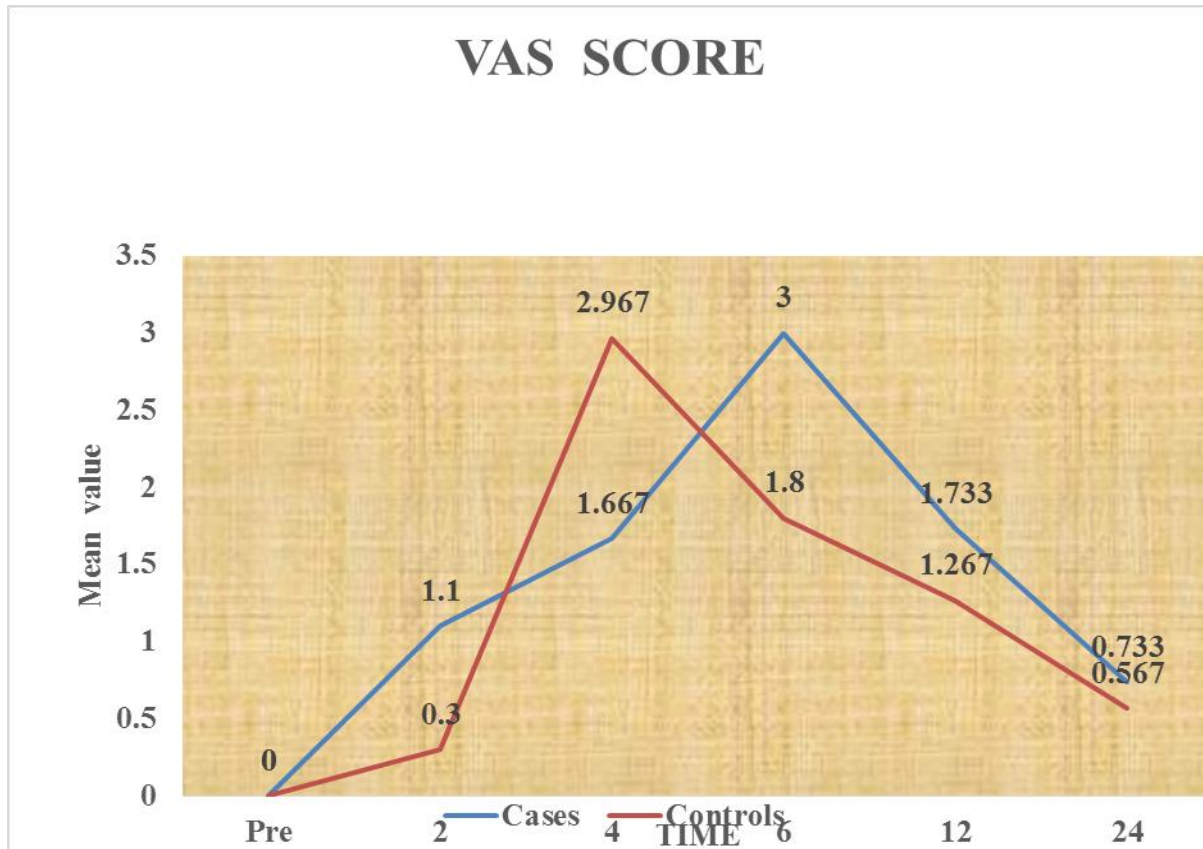
**TABLE 3**  
**Postoperative recovery times and adverse events**

PARAMETERS	GROUP P	GROUP S
Time to first analgesia(min)	348 $\pm$ 39	207 $\pm$ 26*
Time to ambulation ( min)	249 $\pm$ 20	371 $\pm$ 18*
Total analgesia consumption (Tramadol in mg.)	75 $\pm$ 32	161 $\pm$ 36*
Patients with PONV(n)#	1	4
Urinary catheterization(n)#	0	5*
Recovery room bypass(n)#	30	14*

\*Significant (p<0.05)

#Pearson's chi square test was used. For others Fischer's Exact T test was used. Results presented as mean  $\pm$  SD, no. of patients (n), total amount in mg.

**GRAPH 1**



**GRAPH 1** showing VAS scores at different time interval in both groups

## V. DISCUSSION

From our study we found 2 segment Paravertebral block (PVB) as an alternative to spinal anaesthesia in unilateral inguinal hernia.

This was possible due to segmental nature of Paravertebral block (PVB) and persisting sensory block resulting in prolonged pain relief. Even after ambulation patient had good pain relief which was not seen in spinal anaesthesia due to its non segmental nature and complete block of lower thoracic and lumbar segment block and shorter period of analgesia. The findings were similar to Mandal et al in which they compared PVB with unilateral spinal anaesthesia<sup>4</sup>.

Poor recovery room bypass was seen in group S spinal anaesthesia group due to prolonged motor block ( $p < 0.001$ ). Bilateral Spinal anaesthesia (SA) with high dose of Bupivacaine without opioid may explain the delayed ambulation and increased need for recovery room use in the spinal group, probably related to the residual motor and sympathetic blockade. In contrast, ambulation is much earlier after PVB for inguinal hernia repair, probably due to minimum motor blockade of lower extremities in group P. Propofol consumption was higher in group P when compared to group S due to slower onset of block and due to differential innervations of inguinal sac contents and segmental block.

Bhattacharya P et al used 4 segment Paravertebral block in their study on inguinal hernia<sup>3</sup> and Mandal et al used 2 segment PVB in the study. Saito T and his colleagues favoured single injection, multi-segment Paravertebral block as an alternative to multiple injection technique<sup>7</sup>. Although multi-segmental PVB provided good anaesthetic condition, they caused discomfort to patient due to multiple pricks and more chance of pneumothorax in case of higher thoracic levels. Lonnquist and Hildngston described at the level of T 12 psoas muscle interrupted the Paravertebral space<sup>8</sup>. So Mandal et al used 2 segment PVB at T 10 and L 1 and we used same method in our study.

In the spinal anaesthesia group S the use of intra-operative mephentermine was increased due to hypotension which was not seen in Paravertebral block indicating good hemodynamic control in PVB group compared to group S. Five patients (16%) of group S required urinary catheterization after 3 h of post-operative period as compared with none in group P. This increased incidence of urinary retention might be related to hypotension which required more frequent volume expansion, as also assumed by Fanelli et al<sup>9</sup>. In the postoperative period Paravertebral block could avoid the complications seen with spinal anaesthesia like urinary retention and catheterization, postoperative nausea and vomiting (PONV), post dural puncture headache (PDPH). However use of finer small bore pencil-point needles (25G) decrease incidence of PDPH.

Limitations were that Paravertebral block was not routinely practiced was time consuming, chances of failure and higher chances of pneumothorax which increases with increase in number of injections and in thoracic level. The chances of partial block or block failure could be higher due to inexperience with the technique and inconsistent nature of block. We could see patients requiring more propofol in PVB group compared to spinal anaesthesia group. Use of peripheral nerve stimulator

(PNS) or ultrasound guidance block could decrease the failure rate and increase the efficiency of block.

To conclude Paravertebral block can be used as an alternative to spinal anaesthesia in unilateral inguinal hernia repair. Its efficacy can be seen in better hemodynamic control, prolonged postoperative analgesia, no residual motor blockade, early ambulation and decreased urinary retention. The efficiency of Paravertebral block can further be improved by using Peripheral nerve stimulator (PNS) as well as ultra sound guided block.

## REFERENCES

- [1] Beyaz SG, Ozocak H, Ergonenc T, Erdem AF. The thoracic paravertebral block performed for open cholecystectomy operation in order to anesthesia: Two cases. *Anesth Essays Res* 2014; 8: 239-42.
- [2] Bhattacharya P, Mandal MC, Mukhopadhyay S, Das S, Pal PP, Basu SR. Unilateral paravertebral block: an alternative to conventional spinal anaesthesia for inguinal hernia repair. *Acta anaesthesiol Scand*. 2010 Feb; 54(2): 246-251.
- [3] Akcaboy EY, Akcaboy ZN, Gogus N. Ambulatory inguinal herniarrhaphy: Paravertebral block versus spinal anesthesia. *Minerva Anesthesiol*. 2009; 75: 684-91.
- [4] MC Mandal, SDas, Sunil Gupta, TR Ghosh, SR Basu. Paravertebral block can be an alternative to unilateral spinal anaesthesia for inguinal hernia repair. *Indian J Anaesth* 2011; 55: 584-89.
- [5] Bromage PR. A comparison of the hydrochloride and carbon dioxide salts of lidocaine and prilocaine in epidural analgesia. *Acta Anaesthesiol Scand* 1965; 16 (Suppl.): 55-69.
- [6] Marshall SI, Chung F. Discharge criteria and complications after ambulatory surgery. *Anesth Analg* 1999; 88: 508-17.
- [7] Saito T, Den S, Cheema SPS et al. A single injection multisegmental paravertebral block extension of somatosensory and sympathetic block in volunteers. *Acta Anaesthesiol scand* 2001; 45: 30-3.
- [8] Lonnqvist PA, MacKenzie J, Soni AK, Conacher ID. Paravertebral blockade: failure rate and complications. *Anaesthesia* 1995; 50: 813-5.
- [9] Fanelli G, Borghi B, Casati A, Bertini L, Montebugnoli M, Torri G. Unilateral bupivacaine spinal anaesthesia for out-patient knee arthroscopy. *Can J Anesth* 2000; 47: 746-51.

## AUTHORS

**First Author** – Dr. Aswin.A.B Post Graduate Department Of Anaesthesia, Kasturba Medical College, Manipal University Mangalore. Email: aswin.ab2005@gmail.com

**Second Author** – Dr. Suresh Bhat- Associate Professor, Department Of Anaesthesia, Kasturba Medical College, Manipal University Mangalore, email: drsureshyv@hotmail.com

# Glycylglycine as Corrosion Inhibitor for Zinc Metal in Acid Solutions

A.Pasupathy<sup>1</sup>, T.Raja<sup>2</sup>, M.Raja<sup>1</sup>

<sup>1</sup>P.G and Research Department of Chemistry, Urumu Dhanalakshmi College, Tiruchirappalli, Tamil Nadu, India.

<sup>2</sup>Department of Chemistry, Trichy Engineering College, Konalai, Tiruchirappalli, Tamil Nadu, India.

**Abstract-** The effect of glycylglycine was evaluated as a corrosion inhibitor for zinc in 0.5N HCl by weight loss, gasometric and thermometric methods. The inhibition efficiency was found to increase with increase in the inhibitor concentration. The adsorption of the inhibitor molecules on to the zinc metal surface obeyed Temkin adsorption isotherm.

**Index Terms-** Glycylglycine, acidic solutions, zinc corrosion, weight loss, gasometry, thermometry

## I. INTRODUCTION

Though zinc metal stands at 23<sup>rd</sup> place in the relative abundance among the elements in the earth's crust, it stands at 4<sup>th</sup> place in terms of production and consumption worldwide. The first three being iron, aluminium and copper. Due to the numerous industrial applications, zinc metal protection against corrosion gained much attention among the researchers. One of the most efficient methods available for the metal protection is the use of inhibitors<sup>1-9</sup>. Inhibitors bring down the corrosion of metal dissolution by adsorption process. In the present work glycylglycine was evaluated as a corrosion inhibitor for zinc metal in 0.5N HCl using weight loss, gasometric and thermometric techniques.

## II. EXPERIMENTAL

The zinc metal specimens of composition: lead 1.03%, cadmium 0.04%, iron 0.001% and the remainder being zinc and size of 4cm\*2cm\* 0.08cm were used in the present study. The metal specimens were polished, degreased with absolute ethanol and air dried. The inhibitor compound, glycylglycine was procured from Alfa Aesar chemicals of UK. The corrosion medium employed was 0.5N HCl prepared from A.R grade HCl and deionised water.

### Weight loss, gasometry and thermometry studies

Weight loss, gasometry and thermometry studies were conducted as reported earlier<sup>10-14</sup>. From the weight loss experiments, the % inhibition efficiency (I.E) and the degree of surface coverage ( $\theta$ ) were calculated by using the following equations.

$$I.E = \frac{W_o - W_i}{W_o} \times 100$$
$$\theta = \frac{W_o - W_i}{W_o}$$

Where  $W_o$  and  $W_i$  are the weight loss of the metal in the absence and presence of the inhibitor respectively.

The corrosion rate (C.R) of the metal was calculated by using the following equation.

$$C.R(mmy) = \frac{87.6 W}{A t D}$$

Where  $W$  is the weight loss of the zinc metal (mg),  $A$  is the surface area of the metal specimen( $cm^2$ ),  $t$  is the exposure time (h) and  $D$  is the density of the metal ( $g/cm^3$ ).

From the gasometry experiments the inhibition efficiency was calculated by using the following equation.

$$I.E = \frac{V_o - V_i}{V_o} \times 100$$

Where  $V_o$  and  $V_i$  are the volume of hydrogen gas evolved in the absence and presence of the inhibitor respectively.

From the thermometric studies the reaction number was first calculated by using the equation

$$RN = \frac{T_m - T_i}{t}$$

Where  $T_m$  is the maximum temperature,  $T_i$  is the initial temperature and  $t$  is the time taken to attain the maximum temperature.

The inhibition efficiency was calculated by using the following equation

$$I.E = \frac{RN_o - RN_i}{RN_o}$$

Where  $RN_o$  is the reaction number in the absence of the inhibitor and  $RN_i$  is the reaction number in the presence of various concentrations of the inhibitor.

## III. RESULTS AND DISCUSSION

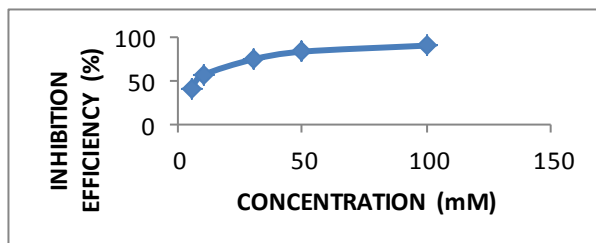
Values of inhibition efficiency obtained from the weight loss, gasometry and thermometry studies for the corrosion of zinc in 0.5N HCl in the presence of different concentrations of glycylglycine are presented in the table 1.

**Table 1 Values of inhibition efficiency obtained from various experiments.**

Method employed	Values of I.E.(%) for different concentrations (mM) of glycylglycine				
	5	10	30	50	100
Weight loss	42.1	57.0	75.2	84.3	91.1
Gasometry	42.2	57.4	74.9	84.9	90.0
Thermometry	43.6	57.9	76.1	85.8	89.7

The results presented in the table1 reveals that the inhibition efficiencies increase with increase in the inhibitor concentration.

The relationship between the inhibition efficiency of the inhibitor and its concentration is shown in figure 1.



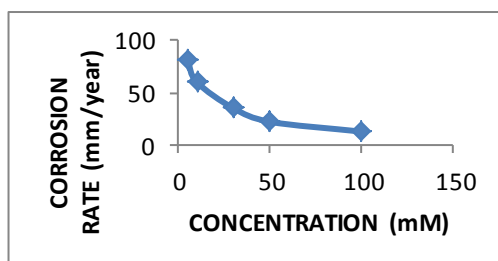
**Figure- 1 Variation of inhibition efficiency with concentration of the glycylglycine for zinc in 0.5N HCl**

Values of corrosion rates (mm/year) obtained from the weight loss experiments for the inhibition for the corrosion of zinc in 0.5N HCl in the presence of different concentrations of glycylglycine is presented in the table 2.

**Table 2 Values of corrosion rates(mm/year) from the weight loss measurements**

Values of corrosion rates (mm/y) for different concentrations (mM) of glycylglycine				
5	10	30	50	100
81.2	60.2	35.0	22.4	12.6

From the table 2 it can be understood that the corrosion rates decreases with increasing concentration of the inhibitor. The effect of inhibitor concentration on the corrosion rates is shown in figure 2.

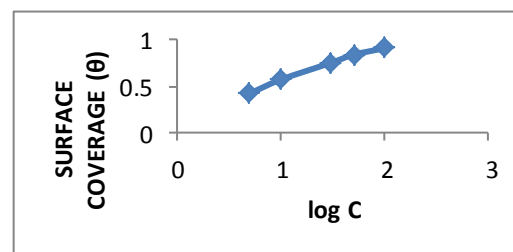


**Figure- 2 Variation of corrosion rates with concentration of the glycylglycine inhibitor for zinc in 0.5N HCl.**

The inhibitor molecule possess many heteroatoms in its molecular structure. These heteroatoms are potential adsorption centers, because they contain lone pairs of electrons. The inhibitor molecule gets adsorbed on to the zinc metal surface through these heteroatoms with lone pair of electrons. This adsorption of the inhibitor molecules on to the metal surface leads to the establishment of a thin film on the metal surface which offers protection to the metal from the acid attack. The inhibitor dipeptide, glycylglycine normally exists in the zwitter ionic form in solution. The chloride ions present in the acid medium adsorb specifically on the zinc metal surface due to its lesser degree of hydration resulting in the creation of excess negative charges on the metal surface. This increases the adsorption of the zwitter ionic form of the dipeptide on to the metal surface leading to enhanced protection of the metal.

#### IV. ADSORPTION ISOTHERMS

The degree of surface coverage ( $\theta$ ) for various concentration(C) of glycylglycine inhibitor was obtained from the weight loss measurements and plotted against log C. The plot resulted in a straight line indicating the adsorption of the inhibitor on to the zinc metal surface follows Temkin adsorption isotherm. Figure 3 shows the Temkin adsorption isotherm.



**Figure-3 Temkin adsorption isotherm plot for corrosion of zinc in 0.5N HCl containing different concentrations of inhibitor.**

#### V. CONCLUSIONS

The inhibitor, glycylglycine used in this work exhibited good inhibition efficiency. It gave 99.1% of inhibition efficiency at a concentration of 100 mM. Inhibition efficiency increased with increase in inhibitor concentration. The adsorption of the inhibitor molecules on to the metal surface obeys Temkin's adsorption isotherm.

#### REFERENCES

- [1] Kawai,S., Kato,H., Hatoushika, Y., and Yasumasa,M., *Denki Kagaku*, 43, (1975) 127.
- [2] Antropov, L.I., *Zasch. Metal.* **6**, (1970) 440.
- [3] Biallazo, S., *Elektrokimiya*, **1**, (1965)1137.
- [4] Aziz, K., and Shams El din A.M., *Corros.Sci.* **5**, (1965)489.
- [5] Ramamani, R., and Shanmuganadhan, S.P., *Current Science*, **37**, (1968)39.
- [6] Machu, W., and Gouda, V.K., *Werkst.Korro.* **13**, (1962)745.
- [7] Antropov, L.I., *Zasch. Metal.* **6**, (1970)440.
- [8] Leroy, R.L., *Corrosion*, **34**, (1978)98.

- [9] Fouda, A.S., Madkour, L.H., Elshafei, A.A., and Elmaksoud, S.A.A., *Bull. Korean. chem.soc.*, **16**, (1995)454.
- [10] S.Muralidharan, M.A.Quraishi and Venkatakrishna Iyer, *Corros.Sci.*,37(1995) 39
- [11] S.Rengamani, S.Muralidharan and Venkatakrishna Iyer, *Ind.Jour.Chem.Tech*, 1 (1995) 168
- [12] B.N.Oza and R.S.Sinha, *Trans.SAEST*, 17(1982) 281.
- [13] R.K.Upadhyay and S.P.Mathur, *E.J.Chem* 4(2007)408.
- [14] A.Y.El-Etre, *Corros.Sci.*43(2001)1031

#### AUTHORS

**First Author** – A.Pasupathy, P.G and Research Department of Chemistry, Urumu Dhanalakshmi College, Tiruchirappalli, Tamil Nadu, India., Tel.: +919003427375, E-mail address:

[pasupathyudc@gmail.com\(A.Pasupathy\)](mailto:pasupathyudc@gmail.com(A.Pasupathy))

**Second Author** – T.Raja, Department of Chemistry, Trichy Engineering College, Konalai, Tiruchirappalli, Tamil Nadu, India.

**Third Author** –M.Raja, P.G and Research Department of Chemistry, Urumu Dhanalakshmi College, Tiruchirappalli, Tamil Nadu, India.



# Triethylenetetramine as a Corrosion Inhibitor for Zinc Metal in Acidic Solutions

A.Pasupathy<sup>1</sup>, T.Raja<sup>2</sup>, M.Raja<sup>1</sup>

<sup>1</sup>P.G and Research Department of Chemistry, Urumu Dhanalakshmi College, Tiruchirappalli, Tamil Nadu, India.

<sup>2</sup>Department of Chemistry, Trichy Engineering College, Konalai, Tiruchirappalli, Tamil Nadu.

**Abstract-** The inhibitive action of Triethylenetetramine on zinc metal was evaluated in 0.5N HCl as corrosion medium, using weight loss, gasometric and thermometric techniques. Parameters such as inhibition efficiency and corrosion rates were evaluated to assess the performance of the inhibitor. The results showed that the inhibitor displayed good corrosion inhibiting properties. The inhibition efficiency was found to increase with increase in the inhibitor concentration. To study the adsorption of the inhibitor on the metal surface, adsorption isotherm was plotted.

**Index Terms-** Triethylenetetramine, acidic solutions, zinc corrosion, weight loss, gasometry, thermometry.

## I. INTRODUCTION

Corrosion of metals and alloys resulted in the loss of many important characteristics such as malleability, ductility and conductance. The strategy to be employed to control the corrosion process is to isolate the metals and alloys from the corrosive environments. Use of corrosion inhibitors is one of the many methods available for securing metals against corrosion. Organic compounds with heteroatoms, multiple bonds and aromatic rings proved to be effective inhibitors. A variety of organic compounds were used as corrosion inhibitors for zinc metal in various environments<sup>1-11</sup>. These inhibitors control the corrosion process by adsorption on to the metal surface. In this work, we have examined Triethylenetetramine as a corrosion inhibitor for zinc metal in 0.5N HCl acid solution by weight loss, gasometry and thermometric methods.

## II. EXPERIMENTAL

The zinc metal specimens of composition: lead 1.03%, cadmium 0.04%, iron 0.001% and the remainder being zinc and size of 4cm\*2cm\* 0.08cm were used for weight loss, gasometry and thermometry studies. Zinc metal specimens were polished with a series of emery papers of various grades from 400-1200, degreased with absolute ethanol and dried. The inhibitor compound, Triethylenetetramine was obtained Alfa Aesar Chemicals of the United Kingdom. The corrosion medium was 0.5N HCl prepared from A.R grade HCl and deionised water.

Weight loss, gasometry and thermometric studies were carried out as reported earlier<sup>12-16</sup>. From the weight loss experiments the % inhibition efficiency (I.E) and the degree of surface coverage ( $\theta$ ) were calculated by using the following equations.

$$I.E = \frac{W_o - W_i}{W_o} \times 100$$

$$\theta = \frac{W_o - W_i}{W_o}$$

Where  $W_o$  and  $W_i$  are the weight loss of the metal in the absence and presence of the inhibitor respectively.

The corrosion rate (C.R) of the metal was evaluated by using the following equation.

$$C.R(mmy) = \frac{87.6 W}{A t D}$$

Where  $W$  is the weight loss of the zinc metal (mg),  $A$  is the surface area of the metal specimen( $cm^2$ ),  $t$  is the exposure time (h) and  $D$  is the density of the metal ( $g/cm^3$ ).

From the gasometry experiments, the inhibition efficiency is calculated by using the following equation.

$$I.E = \frac{V_o - V_i}{V_o} \times 100$$

Where  $V_o$  and  $V_i$  are the volume of hydrogen gas evolved in the absence and presence of the inhibitor respectively.

From the thermometric studies the reaction number was first calculated by using the equation

$$RN = \frac{T_m - T_i}{t}$$

Where  $T_m$  is the maximum temperature,  $T_i$  is the initial temperature and  $t$  is the time taken to attain the maximum temperature.

The inhibition efficiency is calculated by using the following equation

$$I.E = \frac{RN_o - RN_i}{RN_o}$$

Where  $RN_o$  is the reaction number in the absence of the inhibitor and  $RN_i$  is the reaction number in the presence of various concentrations of the inhibitor.

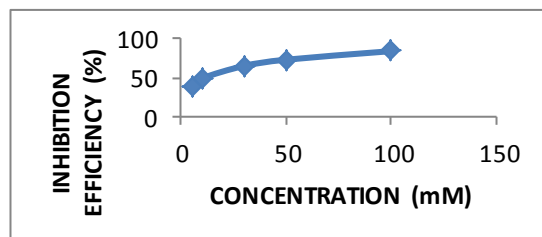
III. RESULTS AND DISCUSSION

Weight loss, gasometry and thermometric studies were conducted and the inhibition efficiency (IE) values were calculated. Values of inhibition efficiency obtained from these experiments are presented in the table-1

**Table 1 Values of inhibition efficiency(I.E(%)) obtained from various experiments.**

Method employed	Values of I.E(%) for different concentrations (mM) of Triethylenetetramine inhibitor				
	5	10	30	50	100
Weight loss	38.0	49.2	64.9	72.8	84.2
Gasometry	37.6	48.4	64.0	71.4	83.1
Thermometry	38.4	49.8	63.4	70.8	83.9

It can be observed from the table 1 that there is very good agreement between the values of inhibition efficiency obtained from these three methods. The results also show that the inhibition efficiency increases with increase in the inhibitor concentration. The dependence of inhibition efficiency of the inhibitor on the concentration is shown in figure-1



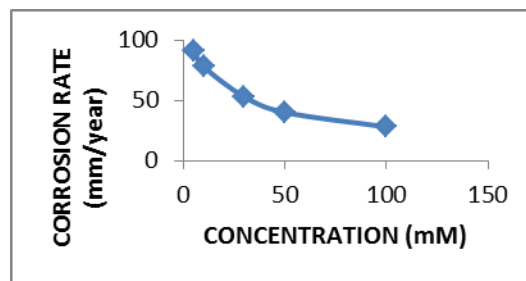
**Figure 1 Variation of inhibition efficiency with concentration of the inhibitor.**

Values of corrosion rates obtained from the weight loss experiments for the inhibitor for the corrosion of zinc in 0.5N HCl in the presence of different concentrations of the inhibitor are presented in the table-2

**Table 2 Values of corrosion rates obtained from the weight loss experiments.**

Values of corrosion rates for different concentrations (mM) of Triethylenetetramine inhibitor				
5	10	30	50	100
91.0	78.4	53.2	40.6	28.1

From the table-2 it can be seen that the corrosion rates for the corrosion of zinc in 0.5N HCl decreases with increasing concentration of the inhibitor. The effect of inhibitor concentration on the corrosion rates is shown in figure-2.

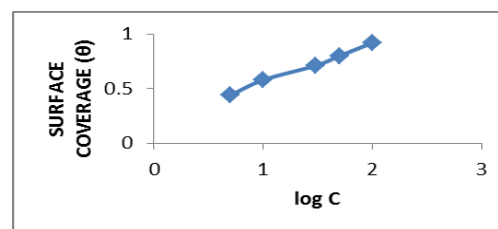


**Figure 2 Variation of corrosion rates with concentration of the inhibitor.**

The inhibitor molecule contains four nitrogen atoms in its molecular structure. These nitrogen atoms possess lone pairs of electrons required for the adsorption process. On adsorption, a strongly adherent layer is formed on the metal surface. This layer acts as a barrier between the metal and the environment giving protection to the metal. In addition to these, the amino groups present in the molecule can be easily protonated in acid medium to form the cationic form of the inhibitor. The chloride ions present in the acid medium gets adsorbed specifically on the positively charged metal surface due to its lesser degree of hydration leading to the creation of excess negative charges on the metal surface which enhances more adsorption and hence protection of the metal. Another factor responsible for the higher inhibition efficiency of the inhibitor is the large surface area of the inhibitor molecules which provides higher surface coverage to the metal after getting adsorbed on to the metal surface.

IV. ADSORPTION ISOTHERMS

From the weight loss measurements, the degree of surface coverage ( $\theta$ ) for various concentrations of the inhibitor were determined. Temkin's adsorption isotherm was tested by plotting  $\log C$  vs  $\theta$  which gave a straight line thereby indicating that the adsorption of the inhibitor on the surface of zinc from 0.5N HCl obeys Temkin's adsorption isotherm. Figure -3 shows the Temkin adsorption isotherm plot for zinc in 0.5N HCl containing different concentrations of the inhibitor.



**Figure 3 Temkin adsorption isotherm plot for zinc in 0.5N HCl containing different concentrations of the inhibitor.**

## V. CONCLUSIONS

Triethylenetetramine used as a corrosion inhibitor for zinc in 0.5N HCl performed well and gave high percentage of inhibition efficiency. The inhibition efficiency of the inhibitor increased with the increase in the concentration of the inhibitor. The adsorption of the inhibitor on to zinc surface obeyed Temkin adsorption isotherm.

## REFERENCES

- [1] Aziz, K., and Shams El din A.M., Corros.Sci, 5, (1965)489.
- [2] Ramamani, R., and Shanmuganadhan, S.P., Current Science, 37, (1968)39.
- [3] Machu, W., and Gouda, V.K., Werkst.Korro. 13, (1962)745.
- [4] Antropov, L.I., Zash. Metal. 6, (1970)440.
- [5] Leroy, R.L., Corrosion, 34, (1978)98.
- [6] Abdel Aal, M.S., Abdel Wahab, A.A., and El Saeed, A., Corrosion, 37, (1981)557.
- [7] Fouda, A.S., Madkour, L.H., Elshafei, A.A., and Elmaksoud, S.A.A., Bull. Korean. chem.soc., 16, (1995)454.
- [8] Mourad, M.Y., Saliman, S.A., and Elmetaal, Bull. Soc. Chim, France, 6, (1991)832.
- [9] Mani, N., Venkatakrishna Iyer, S., and Lal Bahadur, Bull.Electrochem, 19, (2003)53.
- [10] Mani, N., Venkatakrishna Iyer, S., and Lal Bahadur, Trans. SAEST, 38, (2003)67.
- [11] Agarwal, Y.K., Talati, J.D., Shah, M.D., Desai, M.N., and Shah, N.K., Corros.Soc, 46, (2003)633.
- [12] S.Muralidharan, M.A.Quraishi and Venkatakrishna Iyer, Corros.Sci.,37(1995) 1739.
- [13] S.Rengamani, S.Muralidharan and Venkatakrishna Iyer, Ind.Jour.Chem.Tech, 1 (1995) 168
- [14] 15. B.N.Oza and R.S.Sinha, Trans.SAEST, 17(1982) 281.
- [15] 16.R.K.Upadhyay and S.P.Mathur, E.J.Chem 4(2007)408.
- [16] 17. A.Y.El-Etre, Corros.Sci.43(2001)1031

## AUTHORS

**First Author** – A.Pasupathy, P.G and Research Department of Chemistry, Urumu Dhanalakshmi College, Tiruchirappalli, Tamil Nadu, India., Tel.: +919003427375, E-mail address:

[pasupathyudc@gmail.com](mailto:pasupathyudc@gmail.com)(A.Pasupathy)

**Second Author** – T.Raja, Department of Chemistry, Trichy Engineering College, Konalai, Tiruchirappalli, Tamil Nadu, India.

**Third Author** –M.Raja, P.G and Research Department of Chemistry, Urumu Dhanalakshmi College, Tiruchirappalli, Tamil Nadu, India.

# Analysis and Simulation of Crankshaft Manufacturing Unit Using Arena

Faisal KP<sup>1</sup>, Falah Ummer<sup>1</sup>, Hareesh K C<sup>1</sup>, Munavir Ayaniyat <sup>1</sup>, Nijab K<sup>1</sup>, Nikesh P<sup>1</sup>, Jibi R<sup>2</sup>

<sup>1</sup> Graduate Student, <sup>2</sup>Assistant Professor Department of Mechanical Engineering, AWH Engineering College Calicut, Kerala, India

**Abstract-** Discrete event simulation is the process of designing a model of a real system and conducting experiments with that model, for purpose of either understanding the behavior of the system or evaluating strategies for the operation of a system, discrete event simulation is a tool suitable for the study of manufacturing systems and improves the overall efficiency. Arena is a discrete event simulation and automation software developed by Systems Modeling and acquired by Rockwell Automation in 2000. It uses the SIMAN processor and simulation language. In this work, the existing layouts were studied and utilization of each station is analyzed, the efficiency of production depends on how well the various machines, production facilities and employee's amenities are located in a plant.

**Index Terms-** ARENA, Simulation, Utilization

## I. INTRODUCTION

DES (Discrete-Event Simulation) is a tool suitable for the study of manufacturing systems and improves overall efficiency. The manufacturing system can be modeled in a simulation environment to study the different options for improving the system both to predict the effect of changes to an existing system as well as a tool to predict performance of new systems. The work involves analyzing utilization of each work station in the factory lay out. Attempt is made to simulate the factory layout using the software ARENA (student's version). Utilization of each machine is calculated. Bottle neck station in the present manufacturing line, and queues in each work station is identified.

## II. LAYOUT OF INDUSTRY AND DATA COLLECTION

In this work discrete event simulation of a crank shaft manufacturing unit is done by using ARENA software. For stimulating the current manufacturing system using ARENA, the work flow in each station is identified figure 1 shows the work flow of crank shaft in the current lay out. Processing time and inter arrival time in each station is determined. Table 1 shows the processing time and interarrival time in each work station.

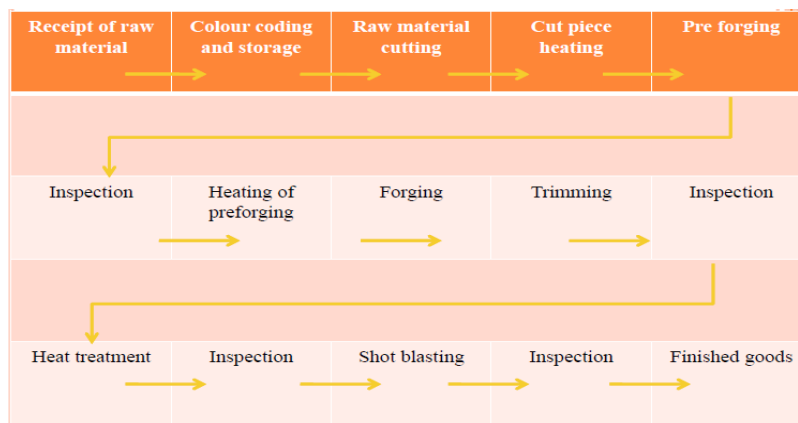


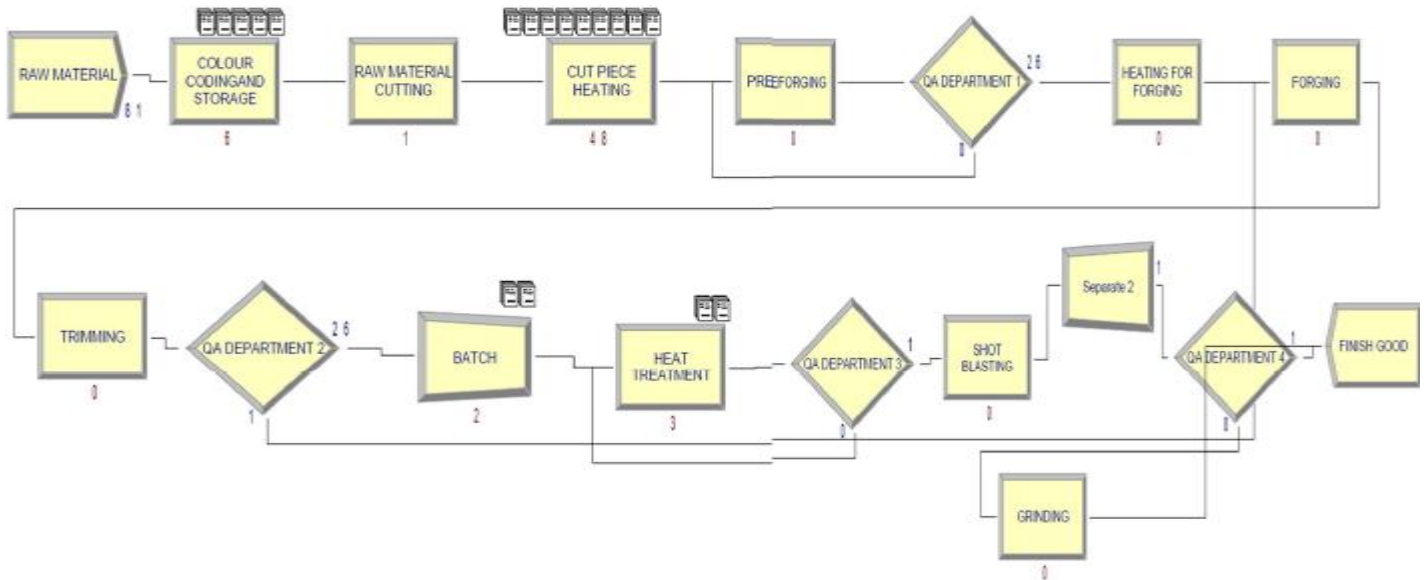
Figure 1: Work flow of crank shaft

WORK STATION	PROCESS TIME (min)	INTER ARIVAL TIME (min)	TOTAL TIME (min)
Receipt of raw material	30		30
Colour coding and storage	25	15	40
Raw material cutting	5.5	5.5	11
Cut piece heating	90	20	110
Pre forging	10	3.5	13.5
Heating of preforging	42.5	15	57.5
Forging	4	5	9
Trimming	.75	3	3.75
Heat treatment	1800	15	1815
Shot blasting	45	2.5	47.5
Grinding	15	5	20 <sup>78</sup>

Table 1: Process time and inter arrival time in each work station

III. RESULTS AND DISCUSSION

- [1]
- [2]
- [3] The figure below shows the layout created by ARENA .9 students' version software. The figure: 2 show the layout that created using the arena software and its simulation. From the software itself we can found the utilization of the machines in the existing layout. The figure: 3 show the utilization of the stations in the existing layout. The figure: 4 shows the total number of parts seized in each work station. During simulation replication length is 50 hours.
- [4]



[5]

Figure 2: Simulation using ARENA



Number of simulation replication = 50 hours

Number of output = 1

Total time for one unit production = 42 hours

12:55:37PM

### Category Overview

January 19, 2015

#### Unnamed Project

Replications: 1      Time Units: Hours

### Key Performance Indicators

#### System

Number Out

Average

1

Figure 3: Simulation using result

Analyzing the current work station utilization

### Usage

Scheduled Utilization	Value
10 TON HAMMER	0.1213
16 TON HAMMER 2	0.08100000
COLOUR CODING AND STORAGE MACHINE	1.0000
FURNANCE 1	0.9830
FURNANCE 2	0.5027
FURNANCE 3	0.7347
GRINDING MACHINE	0.00
POWER HACK SAW	0.2713
SHOT BLASTING MACHINE	0.01492308
TRIMMING MACHINE	0.03600000

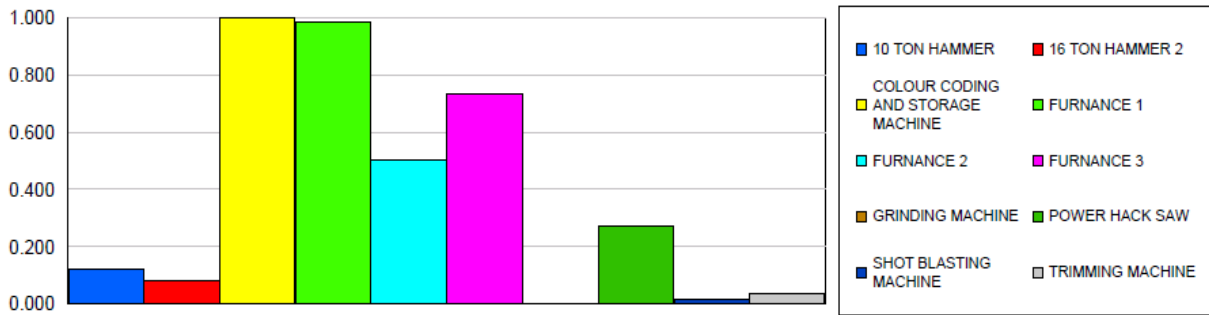


Figure 4: Simulation using result graphical

Total number of seized

Total Number Seized	Value
10 TON HAMMER	26.0000
16 TON HAMMER 2	27.0000
COLOUR CODING AND STORAGE MACHINE	76.0000
FURNANCE 1	27.0000
FURNANCE 2	26.0000
FURNANCE 3	2.0000
GRINDING MACHINE	0.00
POWER HACK SAW	75.0000
SHOT BLASTING MACHINE	1.0000
TRIMMING MACHINE	27.0000

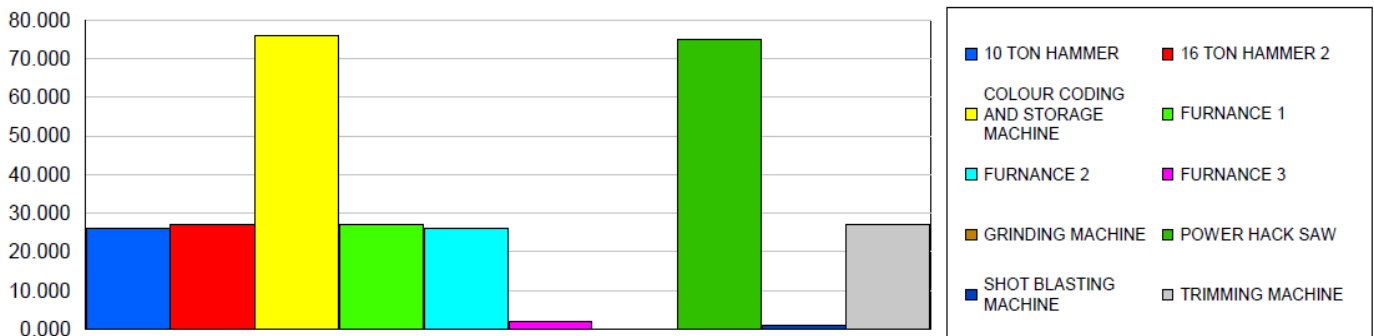


Figure 5: Total number seized

Queue

## Queue Detail Summary

### Time

---

	<u>Waiting Time</u>
BATCH.Queue	4.57
COLOUR CODINGAND STORAGE.Queue	4.57
CUT PIECE HEATING.Queue	15.17
FORGING.Queue	0.00
HEAT TREATMENT.Queue	9.50
HEATING FOR FORGING.Queue	0.00
PREFORGING.Queue	0.00
RAW MATERIAL CUTTING.Queue	0.00
SHOT BLASTING.Queue	0.00
TRIMMING.Queue	0.00

### Other

---

	<u>Number Waiting</u>
BATCH.Queue	2.24
COLOUR CODINGAND STORAGE.Queue	7.11
CUT PIECE HEATING.Queue	23.06
FORGING.Queue	0.00
GRINDING.Queue	0.00
HEAT TREATMENT.Queue	0.75
HEATING FOR FORGING.Queue	0.00
PREFORGING.Queue	0.00
RAW MATERIAL CUTTING.Queue	0.00
SHOT BLASTING.Queue	0.00
TRIMMING.Queue	0.00

## Resource Detail Summary

### Usage

---

	<u>Inst Util</u>	<u>Num Busy</u>	<u>Num Sched</u>	<u>Num Seized</u>	<u>Sched Util</u>
10 TON	0.12	0.12	1.00	26.00	0.12
16 TON	0.08	0.08	1.00	27.00	0.08
COLOUR	1.00	1.00	1.00	76.00	1.00
FURNANCE 1	0.98	0.98	1.00	27.00	0.98
FURNANCE 2	0.50	0.50	1.00	26.00	0.50
FURNANCE 3	0.73	0.73	1.00	2.00	0.73
GRINDING	0.00	0.00	1.00	0.00	0.00
POWER	0.27	0.27	1.00	75.00	0.27
SHOT	0.01	0.01	1.00	1.00	0.01
TRIMMING	0.04	0.04	1.00	27.00	0.04

---

Queues are found at colour coding and storage station and cut piece heating furnaces. Bottle neck station in the current lay out is colour coding and storage work station.100 % utilization for colour coding and storage station.98% utilization for furnace 1.

#### IV.SUGGESTIONS

The following suggestions have been made to improve the utilization of the machines

Queues are found at colour coding and storage section and cut piece heating. Furnaces Bottle neck station in the current lay out is colour coding and storage station. Implementation of one more colour coding and storage facility will reduce the queue in that section. Installation of an extra furnace can solve the queue in cut piece heating.

#### V.FUTURE WORKS

Install one more arrangement for colour coding and storage and a cut piece heating furnace and conduct new simulation to avoid bottle neck in production.

#### VI. REFERENCE

- [1]: Wang, M; G Sun; D Wang. 1993. "Manufacturing Simulation: An Effective Tool for Productivity Improvement". In Proc. 3rd International Microelectronics & Systems '93 Conference, August. Malaysia
- [2]: F. Hosseinpour, and H. Hajihosseini. Importance of Simulation in Manufacturing World Academy of Science, Engineering and Technology 27 2009.
- [3]: Sun, G; T Spedding. 1995. "Application of Discrete Event Simulation to the Activity Based Costing of Manufacturing Systems". In Proc. 4th International Microelectronics Systems'95 Conference, Malaysia
- [4]: Wang, M; G Sun; Nooh. 1995. "Application of Simulation to Reduce Manufacturing Cycle Time". On Workshop of 4th International Microelectronics Systems'95 Conference, May, Malaysia.
- [5]: Anucha Watanapa, Phichit Kajondecha, Patcharee Duangpitakwong , and Wisitsree Wiyaratn, "Analysis Plant Layout Design for Effective Production," IMECS2011March 16-18 2011Hong Kong .

[6] Emmanuel S. Eneyo, "A the use of simulation in facility layout design: a practical consulting experience," Proceedings of the 1998 Winter Simulation Conference.

[7] N. Shariatzadeh, "Software Evaluation Criteria for Rapid Factory Layout Planning, Design and Simulation," 45th CIRP Conference on Manufacturing Systems 2012 n., submitted for publication.

[8] Saifallah Benjafaar "NEXT GENERATION FACTORY LAYOUTS: RESEARCH CHALLENGES AND RECENT PROGRESS" December, 2000

#### AUTHORS

First Author- Faisal KP, Graduate Student, AWH Engineering College Calicut, Kerala, India

Second Author- Falah Ummer, Graduate Student, AWH Engineering College Calicut, Kerala, India

Third Author- Hareesh K C, Graduate Student, AWH Engineering College Calicut, Kerala, India

Fourth Author - Munavir Aniyath, Graduate Student, AWH Engineering College Calicut, Kerala, India

Fifth Author- Nijab K, Graduate Student, AWH Engineering College Calicut, Kerala, India

Sixth Author- Nikesh P, Graduate Student, AWH Engineering College Calicut, Kerala, India

Seventh Author-Jibi R, Assistant Professor, Department of Mechanical Engineering, AWH Engineering College Calicut, Kerala, India

**Correspondence Author** – Author name, email address, alternate email address (if any), contact number.



# Navigation of Mobile Robot in the Presence of Static Obstacles of Various Shapes

Barla Harshini\*, Praveen kalla \*, Dr K Ramji\*\*

\* Department of Mechanical Engineering, MVGR College of Engineering,

\*\*Department of Mechanical Engineering, Andhra University

**Abstract-** The main objective of path planning is to acquire a collision free path for a mobile robot operating in various environments. Diverse approaches and techniques have been implemented to solve a path planning problem by considering certain factors like obstacle shape, its orientation, type of environment etc. Based on the surrounding environment the robot navigates globally or locally. This paper focuses on the navigation of mobile robot operating in a static environment consisting of elliptical and polygonal obstacles. A mathematical formulation has been developed to obtain these paths and also to find the shortest path among them using Centre of Gravity Approach (CGA) and Coordinate Reference Frame (CRF) technique. The simulation results prove the proposed approach to be effective as the robot navigates to the defined target point without colliding with the obstacles in the environment.

**Index terms-** path planning, collision avoidance, mobile robot, static obstacles, off-line environment

## I. INTRODUCTION

Robotics is a fascinating field with a wide range of development and utility, both technically and commercially. In particular, the field of autonomous mobile robots gained serious attention due to the enormous potential in various sectors ranging from simple household to complex industrial, military applications. For instance the role of these autonomous mobile robots had been greatly exploited in areas which include transportation of cargo, unmanned bomb disposal, planet and underwater exploration [1] supermarkets or airports [2] and service for elderly persons. One of the key aspects for fine tuning the navigation of these mobile robots is motion planning which aims to find a suitable collision-free path from an initial configuration to final (target) configuration for a mobile robot moving in an obstacle prone environment. Many techniques and methods had been previously demonstrated and adopted to solve a path-planning problem [3] where each method has its own prominence in attaining the optimal path over others, they possess certain amount of limitations. Distance is termed to be a common criterion for these problems [4]. This paper explains a methodology for a static path planning problem in attaining the shortest path among elliptical obstacle to minimizing the distance of travel thereby reducing the time and cost of travel.

In the past, various obstacle avoidance algorithms had been developed and are briefly classified into two major areas: global path planning and local path planning [5]. In global path

planning (off-line) the robot is familiar with the surrounding environment consisting of obstacles in advance, and navigates in an off-line mode to reach its destination by avoiding the obstacles. On the other hand, in local path planning (on line) the robot is unaware of the surrounding environment in advance; hence the motion planning of a robot is done dynamically from the information given by the sensor. For an on-line path planning it is essential for a robot to begin its initial path through off-line mode and then later it switches to on-line depending on the changes occurring in the obstacle scenario. Therefore it is essential to navigate a robot globally where in the later case it can be extended to a local path planning problem using sensors.

Many path planning methods [6-12] are proposed in the past. The Configuration Space Approach (CSA) is a fundamental approach where a robot is represented as point robot, thus reducing it to a 2-D problem. Roadmap is another approach which is a graph based modeling. Voronoi diagram and Visibility graph are well known road map techniques. In Visibility graph approach the shortest path is recognized by joining the two vertices of a polygon that can see each other in a graph drawn. Path attained through Voronoi diagram is constructed by using a set of data points which are equidistant from 2 or more obstacles and generally the path is not the shortest. Grid method is another classic approach under cell decomposition method where an environmental map is generated with the help of grids. There are few difficulties in this technique like knowing the size of grid, more memory space etc. In Potential Field Approach the robot navigates in the direction of the resultant force. This approach is simple but a robot might be trapped when the opposite forces of equal magnitude get cancelled. These approaches have computational difficulty in higher dimensions or non-polygonal world. Then we have Particle Swarm Optimization and Genetic Algorithm technique which are widely used algorithms for their strong optimization capabilities. The problem of path planning can be solved effectively and efficiently both in static and dynamic environment for various tasks. As they are evolutionary approaches, thus reducing the computational time when combined with classical approaches. The other optimization algorithms are Ant Colony Optimization and Simulated Annealing. Ant colony optimization is used for finding the shortest optimum path to reach the target inspired by the ferret behavior of ants. In the search space Simulated Annealing approach vertices of static and dynamic obstacles are used for finding the optimal path. Most of the approaches have been applied for polygonal obstacles and have attained competent results with a few limitations and also few approaches have been developed for solving elliptical obstacles [13-14].

The main objective of this paper is to control the navigation of a point robot present in an environment consisting of stationary obstacles and has a prior knowledge of the environment as it is a global path planning problem, to attain the shortest path. A mathematical approach has been developed and programmed using matlab which will work for any number of elliptical obstacles with various shapes and orientations. In this paper two elliptical obstacles are taken with various orientations to solve the problem of collision avoidance. The proposed method is integrated with centre of gravity approach and coordinate reference frame technique for solving the path planning problem for both polygonal and elliptical obstacles.

II. Mathematical Approach

The main purpose of path planning is to find a shortest distance path among all feasible paths attained. In this paper navigation of mobile robot in static environment is studied. In the process of solving the problem it is defined as follows. (1) The robot is a point in the configuration space. (2) The robot navigates globally so it has a prior knowledge of the environment and the obstacles present in it. (3) Considered obstacle shape is two ellipses with different orientations.

Depending on the organization of the environment i.e. source, destination and the obstacles (two ellipses) there may be four maximum possible solutions. The solutions are attained through mathematical expressions.

General form of an ellipse with centre (h, k) is:

$$\frac{(x - h)^2}{a^2} + \frac{(y - k)^2}{b^2} = 1$$

Where a, b are semi major and semi minor axes respectively.

As two ellipses are considered there centers are (h<sub>1</sub>, k<sub>1</sub>) and (h<sub>2</sub>, k<sub>2</sub>) with major and minor axes as (a<sub>1</sub>, b<sub>1</sub>) and (a<sub>2</sub>, b<sub>2</sub>) respectively for the first and second ellipse. The orientation of the ellipse form is achieved by the product of rotational matrix with the ellipse equation.

The equation of a straight line is in the form of

$$y = mx + c$$

Where m is the slope and c is a y intercept

A polynomial expression was developed for finding the slope 'm' of common tangent between the two ellipses [15] using the above equations which are given as:

$$Am^4 + Bm^3 + Cm^2 + Dm + E = 0$$

Where, A, B, C, D, E are constants

From the above expression, the value of m is determined. Since it is a forth degree expression the slope m has four values which are the slopes of the four possible paths between the two ellipses. This expression could be justified using simulation software.

III. Matlab Programming

To demonstrate the effectiveness of the approach, it is implemented and executed using matlab software. In this software we designed an environment through programming and performed several computations by altering the source and destination points and also reorienting the ellipses. Here two elliptical obstacles are considered, so a maximum of four feasible

solutions are attained through execution. The shortest length among them is the required optimum path to navigate a mobile robot. Depending on the number of obstacles the possible numbers of solutions will also increase.

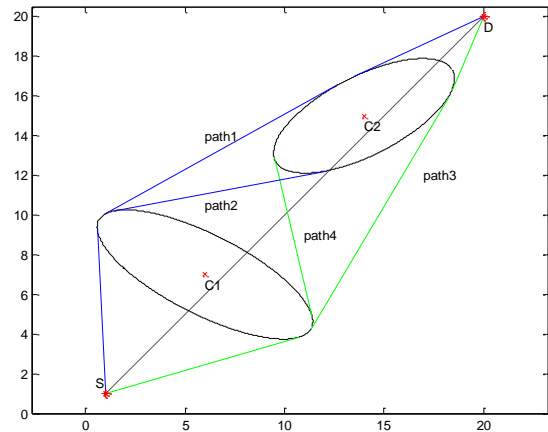


Fig 1: Feasible paths obtained through programming. Here S, D are the source and destination points. SD is a constrained path which is obstructed by the ellipses. C1 and C2 is the centre of the ellipses.

The paths obtained through programming are shown in figure 1. As discussed earlier, in this problem four possible paths are attained with varying lengths, the length of path1 is 30.8338, path2 is 32.9343, path3 is 28.9083 and path4 is 33.2873. The shortest among them is path4 with a minimum length is the required distance to navigate a robot. This reduces the time of travel and also the travelling cost.

Simulation Results

The shortest path could be identified forthwith using centre of gravity approach (CGA) to reduce the time of evaluation. The results obtained through programming using CGA technique [16] for two obstacles is shown in figure 2

A. Two Obstacles:

constrained path which is obstructed by the ellipses. C1 and C2 is the centre of the ellipses.

The data has been shown in table 1.

Table 1: Problem data and optimum solution for two elliptical obstacles

S.No.	Ellipse 1		Ellipse 2		Optimum Path through CGA
	Centre		Centre		
	$h_1$	$k_1$	$h_2$	$k_2$	
1	6	6	15	18	29.3649
2	6	6	15	18	28.5196
3	6	6	15	14	29.4325
4	6	7	15	17	31.0737

Here, the Source is at  $[S_x \ S_y] = [1 \ 1]$

Destination at  $[D_x \ D_y] = [20 \ 20]$

Shortest Constrained Distance is the line joining source and destination = 26.8700

Combinations of feasible paths are attained from the start point to the target point. Among these paths the shortest unconstrained path is required in order to minimize the distance of travel. During the process of attaining these paths it is also necessary to optimize the time of programming in order to acquire the desired results. This is done by incorporating a CG technique to the developed equation in the programming. This technique helps in reducing the evaluation time and also directly generates the shortest path for the navigation of a robot to reach its destination point.

B. Multi obstacles:

The complexity of path planning problem is further increased by including few other obstacles like polygons (regular/irregular) in the environment. For solving such problems we adopt a CRF (Coordinate reference frame) technique [17]. As CRF is a proven method for polygonal obstacles the time and complexity of evaluation for such complex problems is reduced by using it along with mathematical approach and CG technique thus obtaining the shortest path.

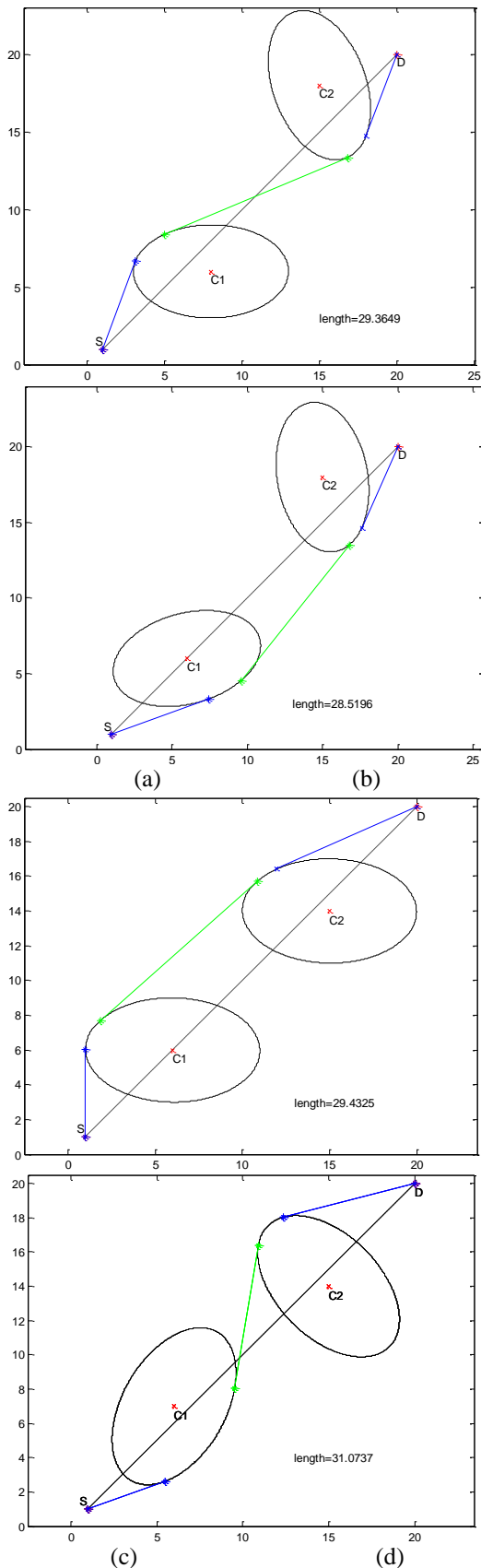
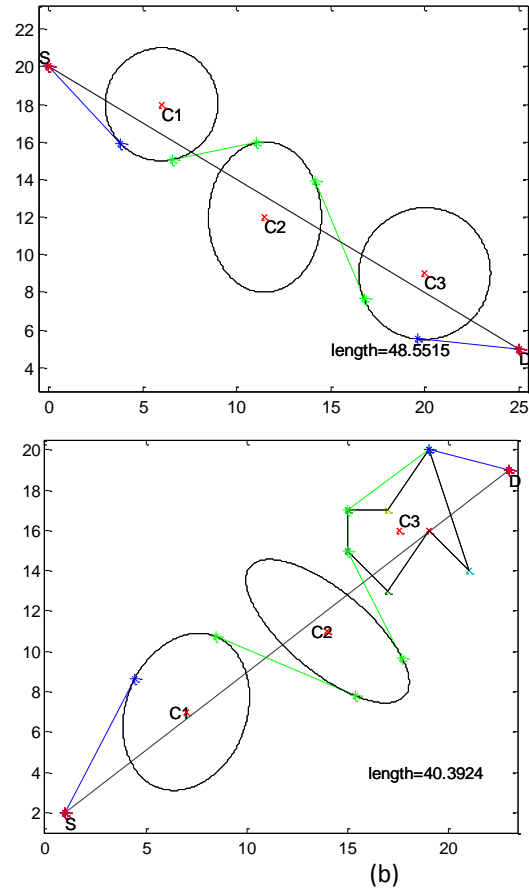
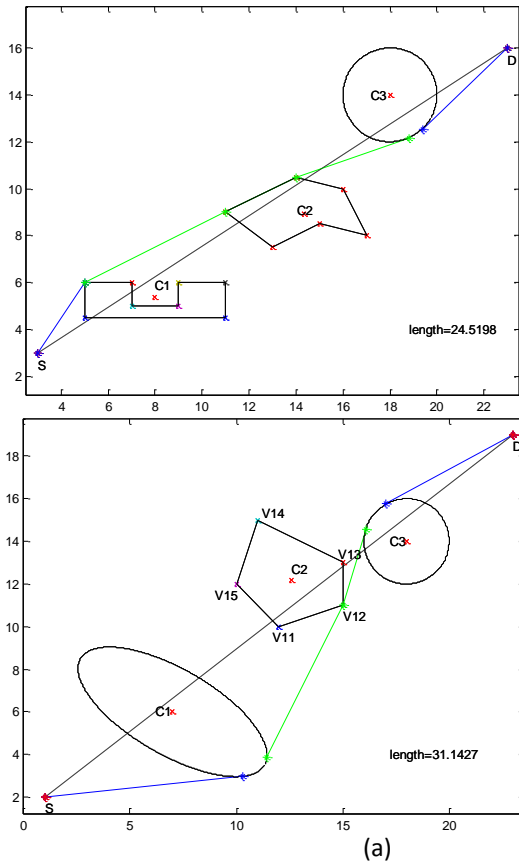


Fig 2: a, b, c, d shows the simulation results for various orientation of the obstacle. Here S,D are the source and destination points. SD is a



( b )

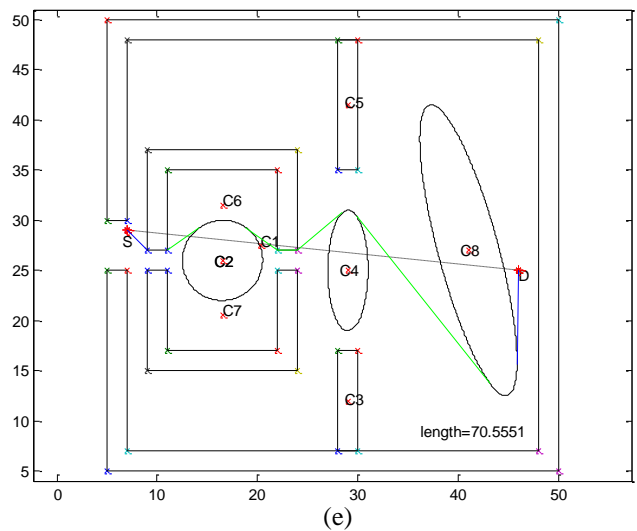


Fig 3: a, b, c, d, e shows the simulation results for various orientation of the obstacle. Here S, D is the source and destination points. SD is a constrained path which is obstructed by the ellipses. C1, C2, C3, C4, C5, C6, C7, C8 are the centers of the obstacles

As can be seen in fig 3, various kinds of paths have been generated successfully for robot navigation in the presence of multiple obstacles through programming. All the generated paths

are the minimum distance paths obtained for the predicted environment.

#### IV. CONCLUSION

This paper presents a simple technique for solving path planning problem in a known static environment. Initially in the problem the considered obstacles are ellipses and in the later it is combined with polygons. To obtain the path between the two ellipses a unique mathematical expression has been developed from the basic equations and it works for any number of ellipses with various orientations. This has been verified from the simulation results by creating an environment in matlab software through programming. CGA is applied to the approach in the programming for finding the shortest path directly from the source to target point to reduce time of evaluation. CRF technique is used along with CGA and mathematical approach for solving multi-obstacle path planning problem to reduce computational complexity and time. The simulation results prove the effectiveness of the proposed approach in solving the path planning problem.

Future works will involve moving obstacle in dynamic 3D environment where the characteristic features like dimensions and velocity are to be considered to make it realistic. Experimentation can also be conducted in complex environments for the proposed approach in real world applications.

#### REFERENCES

- [1] Roque Saltaren Pazmiño, Cecilia E. Garcia Cena,\*, Cesar Alvarez Arocha, Rafael Aracil Santonja, Experiences and results from designing and developing a 6 DoF underwater parallel robot, *Robotics and Autonomous Systems* 59 (2011) 101–112.
- [2] Hefter, Cleaning robot. <http://www.hefter.de/cleantech/roboter.htm>, 2004.
- [3] P. Raja\* and S. Pugazhenthii, Optimal path planning of mobile robots: A review, *International Journal of Physical Sciences* Vol. 7(9), pp. 1314 - 1320, 23 February, 2012.
- [4] Jagadish Chandra Mohanta , Dayal Ramakrushna Parhi , Saroj Kumar Patel, Path planning strategy for autonomous mobile robot navigation using Petri-GA optimization, *Computers and Electrical Engineering* 37 (2011) 1058–1070.
- [5] R.Abiyev, D. Ibrahim \*, B. Erin, Navigation of mobile robots in the presence of obstacles, *Advances in Engineering Software* 41 (2010) 1179–1186.
- [6] Lozano-Perez T, Wesley MA (1979). An algorithm for planning collision-free paths among polyhedral obstacles. *Commun. ACM.*, 22(10): 560–570.
- [7] Lozano-Perez T (1983), Spatial planning: A configuration approach. *IEEE T. Comput. C.*, 32(3): 108-120.
- [8] Siegwart R, Nourbakhsh IR (2011), Introduction to autonomous mobile robot, Massachusetts Institute of Technology press, Cambridge, U.S.A.
- [9] I.AI-Taharwa, A.Sheta, M.AI-Weshah, "A Mobile Robot Path Planning Using Genetic Algorithm in Static Environment", *Journal of Computer Science*, 2008, 4 (4): 341-344.
- [10] Nadia Adnan Shiltagh, Lana Dalawr Jalal, Optimal Path Planning For Intelligent MobileRobot Navigation Using Modified Particle Swarm Optimization, *International Journal of Engineering and Advanced Technology (IJEAT)* ISSN: 2249 –8958, Volume-2, Issue-4, April 2013.
- [11] AlpaReshamwalaDeepika P Vinchurkar, Robot Path Planning using An Ant Colony Optimization Approach: A Survey, (IJARAI) *International Journal of Advanced Research in Artificial Intelligence*, Vol. 2, No.3, 2013
- [12] Miao H, Tian YC (2008). Robot path planning in dynamic environments using a simulated annealing based approach, *Proceedings of the tenth International Conference on Control, Automation, Robotics and Vision*, Hanoi, Vietnam, pp. 1253-1258.
- [13] Avinesh Prasad, Bibhya Sharma, and Jito Vanualailai, Motion Planning and Control of Autonomous Robots in a Two-dimensional Plane, *World Academy of Science, Engineering and Technology*, Vol:6 2012-12-27.

[14] Valeri KROUMOV, Jianli YU, Hiroshi NEGISHI, Optimal Path Planner for Mobile Robot in 2D Environment, *Systemics, Cybernetics and Informatics* Volume 2 - Number 3.

[15] The elements of coordinate system by S.L.Loney Cartesian coordinate part-1.

[16] Dr. V V Rama Reddy, Some Studies On Optimum Facility Location In The Presence Of Polygonal, Circular And Mixed Forbidden Regions, PhD dissertations 2008

[17] RavindraNadh, Path Planning Of Mobile Robots In The Presence Of Polygonal Obstacles, PhD dissertations 2008.

#### AUTHORS

**First Author** – Barla harshini, M.tech, Department of Mechanical Engineering, MVGR College of Engineering, [harshini.brl@gmail.com](mailto:harshini.brl@gmail.com).

**Second Author** – Praveen kalla, (PhD), Department of Mechanical Engineering, MVGR College of Engineering, [praveenkalla@mvgce.edu.in](mailto:praveenkalla@mvgce.edu.in).

**Third Author** - Dr K Ramji, PhD, Department of Mechanical Engineering, Andhra University [ramjidme@gmail.com](mailto:ramjidme@gmail.com).

**Correspondence Author** – Barla harshini, [harshini.brl@gmail.com](mailto:harshini.brl@gmail.com).

# A Performance Prediction of Worm-Worm Wheel and its Multi Objective Design Parameter Optimization Based on Genetic Algorithm

Mokara Bharati\*, V. DeepikaPoornima\*, S.Jyothrimai\*

\*Department of Mechanical Engineering, MVGR College of Engineering,

**Abstract** -The optimization of gear design is a challenging problem as the design variables are interrelated to each other. Various methods have been proposed for solving such problems. This paper aims in developing a methodology for acquiring the desired worm gear design configuration by altering the optimum set of worm gear design parameters which are suitable for the required performance by associating it with SVM (Support Vector Machine). An evolutionary technique like Genetic algorithm (GA) is also used along with it for optimizing the worm and worm wheel with multi objectives, the main object is to attain high wear capacity by considering module, power, velocity ratio, and speed as design parameters. Center distance and strength of worm gear are the constraints taken into consideration.

**Index terms** - Genetic Algorithm, Multi objective optimization, Worm and Worm Wheel database, Support Vector Machine

## I. INTRODUCTION

Worm gears are used for transmitting power between two non-parallel, non-intersecting shafts and in applications where the speed reduction ratio is between 3:1 and 100:1 and in situations where accurate rotary indexing is required. High gear ratios of 200:1 can also be obtained. In the evaluation of worm and worm gear designs, certain basic gear design performance metrics such as tooth bending stress, contact stress, surface fatigue strength, allowable surface fatigue stress, tooth surface strength of gear and pinion etc. are to be carefully considered. The effectiveness of the gear design can be improved only when all these metrics are controlled properly. Despite attempts by several gear designers to improve the efficiency of the gears, the control of all these metrics and achieving a desired performance is a very complicated task. In this paper, an attempt is made to develop a prediction model based on SVM that maps the gear design parameters such as module, velocity ratio, power, speed, etc. with gear design performance metrics. The benefit of such prediction model is a significant reduction in processing time as well as enhanced flexibility in the development of worm gear designs. Yet another problem is however faced by the designer in terms of arriving at the right combination of design parameters in order to achieve a required performance metrics. Currently, this task is highly dependent upon designer expertise. In this work, GA has been combined with SVM in order to develop a fast and accurate search and optimization model.

## II. LITERATURE SURVEY

Extensive research has been made for predicting the gear design performance metrics to reduce lead time of a product. In conventional method, distributed support vector machines (SVM) algorithms are trained over pre-configured intranet/internet environments to find out an optimal classifier. These methods are very complicated and costly for large data sets. Hence, I.W. Tsang, et.al, [1] proposed a method that is referred as the Cloud SVM training mechanism (Cloud SVM) in a cloud computing environment with Map Reduce technique for distributed machine learning applications. P.H. Chen et.al, [2] studied sequential minimal optimization type decomposition methods under a general and flexible way of choosing the two-element working set. F. Chang et.al, [3] shows that decision tree can be used to accelerate the training and testing of support vector machines (SVMs). M. Yaman et.al, [4] In this papers discussed about a non-conventional algorithm namely genetic algorithm is presented for minimization of power-loss of worm gear mechanism with respect to specified set of constraints.. V. Savsani et.al, [5] presents two advanced optimization algorithms known as particle swarm optimization (PSO) and simulated annealing (SA) to find the optimal combination of design parameters for minimum weight of a spur gear train. C. Gologlu et.al, [6] He is discussed about automated preliminary design of gear drives by minimizing volume of gear trains a stochastic approach Genetic Algorithm (GA) was applied to a parallel axis two stage helical gear trains problem. S. Caballero et.al, [7] in his paper presented a genetic algorithm (GA)-based optimization procedure for the design of gear transmissions and discussed about the importance of Evolutionary Techniques like Genetic Algorithm (GA) . Y. K Mogal et.al, [8] in his paper made an attempt to optimize worm and worm wheel with multiple objectives, The main objective function is to minimize volume of worm and worm wheel and remaining objectives are taken as constraints such as centre distance, deflection of worm and beam strength of worm gear.

## III. WORM-WORM GEAR DESIGN

The problem statement of the current work is, to carry out optimization of worm and worm wheel considering maximization of Wear capacity of worm and worm wheel as an objective. A worm and worm wheel design performance



prediction model was first developed using SVM. In order to develop a SVM based prediction model, a variety of gear design models has been developed through analytical approach. The various design parameters affects the analytical analysis of the worm and worm gear, which are taken as velocity ratio, power, speed, module. Several gear design models in the range of module 4mm-16mm, velocity ratio 18-31, teeth on worm 1-5, power 0.1-300KW, speed of the pinion shaft 40-3000 rpm are taken for analytical analysis to evaluate the gear design performance metrics such as bending fatigue stress, wear capacity, heat dissipation, heat generation, for each of these designs it is executed separately in MATLAB. Several design models has been performed and a huge data base has been obtained to run SVM prediction model using the analytical analysis based program. This algorithm has been developed in such a way that the required input design parameters and the required output performance metrics are evaluated using the procedure for gear design according to American Gear Manufacturing Association (AGMA) standard.

#### A. Performance Analysis Using Data Base

In order to evaluate performance of worm gear design analytical analysis data base, bending fatigue, wear capacity, heat generation, and heat dissipation. The analytical analysis of worm and worm wheel was done by varying velocity ratio, module, power, and speed. The data related to performance, was simultaneously recorded and the results obtained from theoretical analysis were plotted. Output parameters were executed in MATLAB. The results are compared with AGMA standards using standard gear relations. [9-11]

#### B. SVM(Support Vector Machine) Prediction Model

In this paper, an attempt is made to develop a forward mapping model using SVM to predict the worm and worm gear performance under varying design conditions. The SVM model can easily be developed by assigning a few parameters namely the kernel function, the cost function etc. Unlike with ANN (Artificial Neural Network) where the architecture has to be developed in advance, the SVM model is easy to build and at the same time it generates a unique solution after training. The goal of SVM is to find out a function that gives a deviation of error from the actual given output and at the same time is as flat as possible. This is achieved by mapping the training patterns from the input space to a high dimensional feature space in such a way that the data which could not be separated by a linear function in the input space can be separated in the feature space. Thus, in arriving at a suitable SVM Model for the given sparse data, the only parameters that the user deals with and has to specify are the kernel function, type of loss function, the error goal, the constant and the width of the radial basis function. This makes it convenient to use SVM in the prediction of the output variable for a given combination of input variables especially in a situation where collection of data for training the model is difficult. Analytical analysis was conducted and the data generated for various design conditions. In order to develop a prediction model a program has been developed and executed in MATLAB. Input parameters for the SVM model were taken as velocity ratio (18-

31), module (4-16mm), power (0.1-300KW) and speed (40-3000rpm). The output parameters were taken as bending fatigue, wear capacity, heat generation. A total of 200 data points were obtained from analytical analysis of which 190 were used to develop the model.

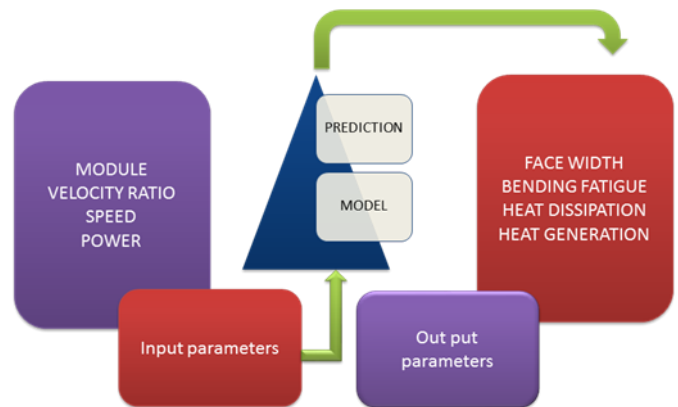


Fig 1- SVM forward mapping prediction model

#### C. Gear Design Optimisation With Genetic Algorithm (GA)

Genetic algorithm is based on evolutionary processes and Darwin's concept of natural selection. It works on the principle that, only the fittest populations will survive while the bad populations are weeded out. The same concept is extended to the mathematical optimization problems where only good design points are selected while the bad design points are neglected. Figure 2 shows that an initial population is chosen randomly at the beginning and fitness of initial population individuals is evaluated. Then an iterative process starts until the termination criteria have been run across. After the evaluation of individual fitness in the population, the genetic operators, selection, crossover and mutation are applied to breed a new generation. The newly created individuals replace the existing generation and re-evaluation is started for fitness of new individuals. The loop is repeated until acceptable solution is found. In this paper Multi-objective optimization of worm and worm wheel is carried out. The main issue in design of worm and worm wheel is, it should be compact i.e. its wear capacity high, centre distance should be less, there should be no deflection of worm and also it should have high strength. All these objectives are considered here to get the best performance of worm and worm wheel.

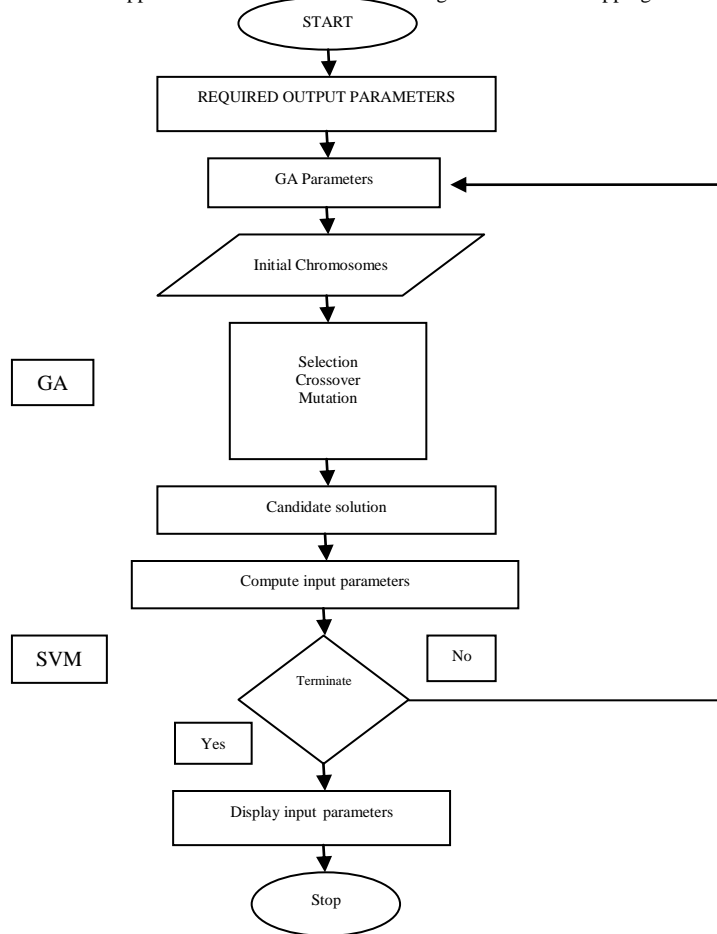
#### D. Reverse Mapping Methodology

The estimation of gear design performance metrics for a worm gear pair requires representation of the influence of design parameters on gear design performance metrics and estimation of the optimum design parameters that would yield a required performance. This involves a combination of regression mapping and optimization. SVM and Genetic Algorithms (GA) are used in this concept to build a forward-reverse mapping model for optimization of gear design performance. As shown in Figure 2, the gear design parameters are sent to the software-based forward mapping model that has been built to map the relationship between the design parameters and performance metrics. For the

given operating conditions, the forward mapping model predicts the performance. The desired optimum performance is defined so that the designer always operates under these conditions. This is achieved by linking the artificial intelligence based reverse mapping model with the forward mapping model. The reverse

mapping model estimates the optimum performance metrics from a range of design parameter solutions that satisfy the require model.

Fig 2: Flow chart of the Support vector machine and Genetic algorithm reverse mapping methodology



#### IV. RESULT AND ANALYSIS

Support vector machine (SVM) Results Analysis - The predicted values from the SVM model were found to be very close to the actual values obtained through analytical analysis. In the case of bending fatigue, it can be observed from Figure 3 and table 1 that the SVM predicted values and the values obtained from experimentation are fairly close. As comparison between theoretical and SVM approach the correction values are dominant while error values are less in number. The output parameters are bending fatigue, wear capacity, heat generation, and heat dissipation ha 70%, 69%, 90%, 80%. Similar values lies in between 20% to 40% from result. It is observed that the SVM model developed is able to map the relationship between design parameters and performance attributes very accurately.

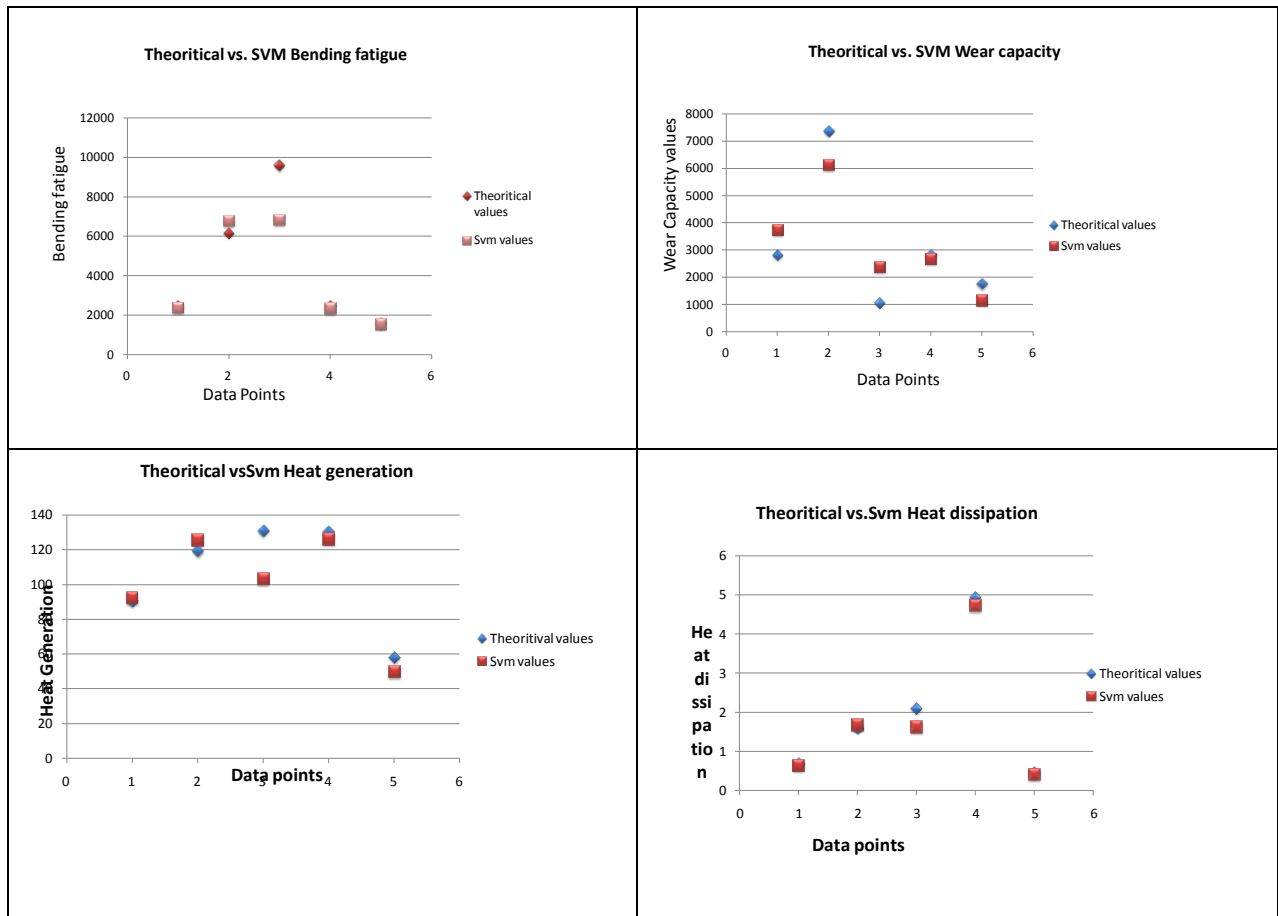


Fig 3: Shows the theoretical and support vector machine prediction model results for bending fatigue, wear capacity, heat generation, Heat dissipation

Table1 - Theoretical and SVM values of all the performance metrics

OUT PUT PARAMETERS											
Input Parameters				Wear Capacity		Bending Fatigue		Heat generation		Heat dissipation	
Power W	Speed N	V.R	m	Theoretical	SVM	Theoretical	SVM	Theoretical	SVM	Theoretical	SVM
900	1500	28	5	2435	2388.4	2812	3732.4	90.5500	92.4998	0.6864	0.6520
900	1500	29	8	6168	6806.3	7377	6123.9	119.2000	125.7791	1.6050	1.6842
900	1500	27	10	9603	6895.3	1069	2374.7	131.0000	103.2990	2.1060	1.6335
900	1500	28	16	2445	2356.8	2823	2686.1	130.5000	126.2198	4.9390	4.7269
700	1200	27	4	1569	1543.3	1747	1157.9	58.2000	49.5800	0.4456	0.4061
700	1200	30	5	2435	2367.6	3013	3899.3	62.9000	64.2460	0.7613	0.7435
700	1200	29	8	6168	6658.1	7377	6124.5	81.7000	85.5800	1.6050	1.6376
800	1800	29	10	9603	9525.9	1148	2406.7	116.5000	118.7446	2.3440	2.3114
1000	1800	28	4	1569	1708.6	1812	1243.5	101.2000	100.0829	0.4704	0.4713
200	600	20	16	2445	2483.2	2016	1968.5	23.1000	23.7333	3.0180	3.0455

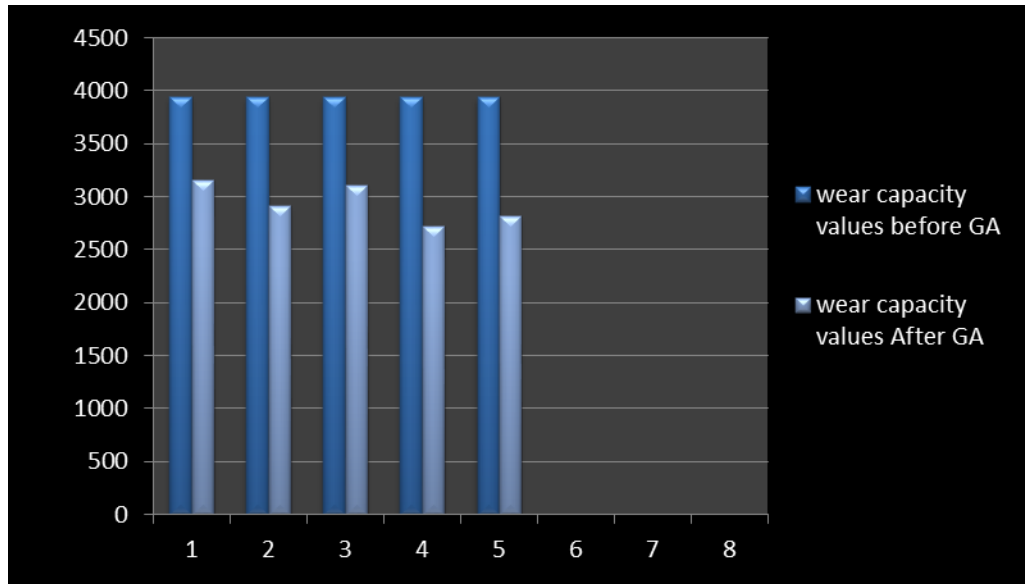


Figure2 - Graph showing the variation of required wear capacity and output of Genetic Algorithm (GA)

Table 2 - Comparison values of wear capacity & Objective Function, Which are obtained actually and by using Genetic Algorithm

S.No	Wear Capacity	
	Before GA	After GA
1	3943.04	3154.46
2	3943.04	2912.92
3	3943.04	3113.44
4	3943.04	2722.01
5	3943.04	2812.67

## V. CONCLUSION

Theoretical analysis was conducted on a worm and worm gear based on performance where SVM prediction model was developed. The developed SVM model is able to offer accurate prediction of the performance parameters for a given set of design values in comparison with actual analytical data with an error of less than 5%. Using this model, it is possible to estimate quickly the performance of the worm and worm gear design. The benefit of such a prediction model is significant reduction of processing time as well as enhanced flexibility in the design performance. If more parameters are considered over a wider range of parameters, it would certainly make the SVM model a lot more robust and thereby greatly enhance the accuracy of the Genetic Algorithm multi objective optimization in obtaining the best gear design model within the defined constraints.

## REFERENCES

[1] I.W. Tsang, J.T.Y. Kwok, P.M. Cheung, "Core Vector Machines: Fast SVM Training on Very Large Data Sets", *J. Mach. Learn. Res.* 6, 363–392, 2005.  
 [2] P.H. Chen, R.E. Fan, C.J. Lin, "A Study on SMO- Type Decomposition Methods For Support Vector Machines", *IEEE Trans. Neural Netw.* 17 (4), 893–908, 2006.

[3] F. Chang, C.Y. Guo, X.R. Lin, C.J. Lu, "Tree Decomposition for Large-Scale SVM Problems", *J. Mach. Learn. Res.* 11, 2935–2972, 2010.  
 [4] M. Yaman, H. Saruhan, and F. Mendi, "Power Loss Optimization of A Worm Gear Mechanism By Using Genetic Algorithm" Technical Education Faculty, Machine Design And Construction Department, Turkey.  
 [5] V. Savsani, R.V. Rao and D.P. Vakharia, "Optimal Weight Design Of A Gear Train Using Particle Swarm Optimization And Simulated Annealing Algorithms", *Mechanism And Machine Theory*, Vol.45, Pp. 531–541, 2010.  
 [6] C. Gologlu and M. Zeyveli, "A genetic approach to automate preliminary design of gear drives", *Computers & Industrial Engineering*, Vol.57, Pp. 1043–1051, 2009,  
 [7] S. Caballero, V. Colomer and R. Romero, "Cylindrical parallel gear trains design by means of genetic optimization", *Selected Proceedings From The 12th International Congress On Project Engineering*, Pp.150-160, 2008.  
 [8] Y.K. Mogal and V.D. Wakchaure, "A Multi-objective Optimization Approach for Design of Worm and Worm Wheel Based on Genetic Algorithm" *Bonfring International Journal of Man Machine Interface*, Vol.3, No.1, March 2013.  
 [9] V.B. Bhandari, "Design of machine elements", *Tata Mcgraw-Hill Education*, 2010.  
 [10] S.S. Rao, "Engineering Optimization, Theory & Practice", *New Age International Publishers*, 3rd edition, 2010.  
 [11] D.E. Goldberg, "Genetic Algorithms, In Search Optimization & Machine Learning", *Pearson education*, 4th edition, 2009.

AUTHORS

**First Author** – Mokara Bharati, M.Tech in Department of mechanical engineering, M.V.G.R College of Engineering, [bharatimokara29@gmail.com](mailto:bharatimokara29@gmail.com).

**Second Author** – V.Deepika Poornima , M.Tech in Department of mechanical engineering, M.V.G.R College of Engineering, [deepikapoorani@gmail.com](mailto:deepikapoorani@gmail.com).

**Third Author** - S.Jyothirmai, M.Tech in Department of mechanical engineering, M.V.G.R College of Engineering, [jyothirmai.srinathu@gmail.com](mailto:jyothirmai.srinathu@gmail.com)

**Corresponding Author** - Mokara Bharati, [bharatimokara29@gmail.com](mailto:bharatimokara29@gmail.com)

# Hotel Revenue Management and Its advantages and Disadvantages to Organization, its employees and customers

Noopur Sharma

FHMCT at MS Ramaiah University Of Applied Sciences

**Abstract-** This research talks about the concept of revenue management and its adoption by the hotel industry. The study made analysis of its pros and cons for the management as well as its employees and guest. Revenue Management moves parallel to strategic and competitive pricing and elasticity of demand in the competitive market. It Later highlights the reasons of revenue management being used in the hotel industry.

**Index Terms-** Revenue Management, organization, employees, customers, guests, advantages and disadvantages.

## I. INTRODUCTION

Kasavana and Brooks (1998), indicate that the idea of revenue management was introduced by the airlines in 1980s as yield management. In reference to Huefner (2014), airline industry used this to understand and compare the approach of saleable services, with an ability to forecast demand. The concept was adopted by the hotel industry to understand the trends and maximization of revenue. Matching the correct means of trade, revenue management aims at providing the appropriate commodity aimed at the correct customers at the suitable time and price, creating value for money (Hospitality net 2013).

Hospitality Professional Association (HOSPA) (2013), argues that one of the main function of revenue management is to evaluate the profit earned to maximize revenue for hotel's inventory and other Points of Sale (POS). According to Dr. Forgacs (2013), revenue management favors market segmentation, improvements in business plans, forecasting elasticity of demand and strategic pricing like discounts, packages, commercial rates compliments etc. It segments the market by understanding target customers, appropriate time and demand with its fluctuating prices and strategies. Keeping in mind the customers' potential and as well as preferences, gives data to forecast revenue and profit. Revenue Management is an advantage for the hotel industry but it can only be applied to financially sound hotels. Implementation requires a lot of capital that is invested both for automation and operations (Enz *et al.* 2012). AHLA (2006), states that revenue management will be detrimental in a hotel with financial issues as expense would increase with no guaranteed results. According to Baker, et al. (2000), strategic and differential pricing such as offering different rates at different time to different guest and lack of customer education might result in losing good or regular guests (Hospitality net 2013). As revenue management involves more analytical approach, it is very time consuming to analysis and

understand its results (Abbott and Lewry 1999; Hayes and Miller 2011; Enz *et al.* 2012).

Cross (1997), states that as the hotel's demand is forecasted it gives employees an edge to co-ordinate manpower and improve inter-departmental communication. According to Hayes and Miller (2011), revenue management helps employees take ownership of their work, increased incentive and bonuses, and increased opportunity for training and development. Cross (1997), argues that it involves very analytical approach. This makes it very complicated for an operational employee to understand and implement. Abbott and Lewry (1999), highlight the difficulties faced by an untrained professional.

(Baker, et al.2000; Hayes and Miller 2011), indicates towards the increase in guest satisfaction varying in demand and preferences from time to time. Legohérel, et al. (2013), strategic analytical pricing of rooms would help the guest in comparing different rates of different rooms and choose the service standard according to its paying potential and self-satisfaction. Revenue management helps to increase communication with the expected guest, as hotels nowadays are widely assessable in different networks internet, on calls, e-mails etc. Ismail (2002), compares revenue management to best available rate or (BAR) rate as different pricing techniques would give optimum service in minimal rates. However Cross (1997), does not support the above argument as fluctuating demands and rates might make the guest feel cheated. Guests believe that it would be unfair to pay an increased price for a particular service or preference if not reserved earlier. Agreeing to the same Yeoman and McMahan-Beattie (2011), state that strategic and differential pricing creates confusion for the guest not identifying the true value for money for the customer.

## II. CONCLUSION

Counting on the research made above the inclination would be towards preferring the usage of Revenue Management in hotels. To survive and explore in the competitive market it is very essential to understand and segment the market according to guest, there availability and preferences, maximizing profit at the best available rate for the hotel consistently. Revenue Management acts as the key tool which helps an organization to understand and develop themselves both internally and externally, to survive and create the best value for money for the guest.



#### REFERENCES

- [1] Abbott, P. and Lewry, S. (1999) *Front Office Procedures, Social Skills, Yield And Management*. 2nd Ed. A division of Reed Educational and Professional Publishing Limited
- [2] Baker, S., Huyton, J. and Bradely, P. (2000) *Principles of HOTEL Front Office Operations*. 2nd Ed. Canada: Nelson Education Limited
- [3] Cross, R. (1997) *Revenue Management*. New York: Broadway Books
- [4] Enz, C., Canina, L. and Noone, B. (2012) *Strategic Revenue Management and the Role of Competitive Price Shifting*. 1st ed. [eBook] Cornell University School of hotel administration, p.1. Available at: [https://online.uwl.ac.uk/bbcswbdav/pid-1365951-dt-content-rid-1537407\\_2/courses/TH5BA39O\\_01-SEP-14\\_16-JAN-](https://online.uwl.ac.uk/bbcswbdav/pid-1365951-dt-content-rid-1537407_2/courses/TH5BA39O_01-SEP-14_16-JAN-)[Accessed on 26 Oct. 2014]
- [5] Hayes, D. and Miller, A. (2011) *Revenue management for the Hospitality Industry*. Hoboken, N.J.: Wiley
- [6] Hospitality Net, (2013). *Hospitality Net - Revenue Management Challenges for 2013 A Top-Five List* By Dr. Gabor Forgacs. [online] Available at: <http://www.hospitalitynet.org/news/4059233.html> [Accessed on 15 October 2014]
- [7] Hospitality Net, (2013) *Hospitality Net - Hospitality Industry Finance, Revenue Management and IT Professionals of the Year, named at Annual HOSPA Christmas Awards 2013*. [online] Available at: <http://www.hospitalitynet.org/news/4063457.html> [Accessed on 26 October 2014]
- [8] Huefner, R.J. 2014, "An Introduction to REVENUE MANAGEMENT", *The CPA Journal*, Vol. 84, No. 6 pp 16
- [9] Legohérel, P., Poutier, E. and Fyall, A. (2013) *Revenue Management for Hospitality and Tourism*. Woodeaton, Oxford: Goodfellow
- [10] Ismail, A. (2002) *Front Office Operations and Management*. New Delhi, India: Cengage Learning India Private Limited
- [11] Kasavana, M. and Brooks, R. (1998) *Front Office Procedures*. 5th ed. United States of America: Educational Institute of the American Hotel and Motel Association
- [12] Ahla, 2006, (2006) *Revenue Management*, 2nd ed. [online] Available at: <http:// American Hotel and Lodging Association> [Accessed on 2 October 2014]
- [13] Yeoman, I. and McMahon-Beattie, U. (2011) *Revenue Management*. Houndmills, Basingstoke, Hampshire: Palgrave Macmillan

#### AUTHORS

**First Author** – Mrs. Noopur Sharma, Bachelors Of science In Hospitality and Hotel administration Lecturer rooms Division at M S Ramaiah university Of Applied Sciences, Bangalore ,India  
[noopur.sharma1490@gmail.com](mailto:noopur.sharma1490@gmail.com)

# Experimental Investigation on Watt Governor to Increase Minimum Speed

GiriBabu Surarapu<sup>1</sup>, Shashidar PeddiReddy<sup>2</sup>, Nagamani Uotkuri<sup>3</sup>

<sup>1</sup>M Tech (Machine Design) SIT, Khammam, Telengana, India

<sup>2</sup>M Tech (Machine Design) KITS, Khammam, Telengana, India

<sup>3</sup>M Tech (Cad / Cam) S.V.E.C, Suryapet, Telengana, India

**Abstract-** The function of the governor is to maintain the mean speed of the engine with in specified limits whenever there is a variation of the load. The objective of our investigation is modifying the Watt Governor (pendulum type) to increase minimum speed limit. [2] Generally we seen that watt governor is best suitable for 60-80r.p.m minimum speeds only, in our study we extend lower arm and fly ball position of the watt governor to the downside from the intersection of link and arm, and then we derive the equation for governor speed. We fabricated the model of governor and observed effect of the extension of lower link and fly ball weight on minimum speed of the governor. This analysis carried out by extension of lower links of the governor and position of fly balls.

**Index Terms-** Extension of lower links, position of fly balls, minimum speed of the governor, central sleeve load.

## I. INTRODUCTION

A Governor, or speed limiter is a device used to measure and regulates the fuel supply to the engine with respect to the engine load variations, when a load on the engine increases sleeve move downwards and due to attached bell crank lever to the supply valve, the fuel supply will decreases and vice-versa. This can regulate the fuel supply to the engine automatically. A classic example is the centrifugal governor, Also known as the watt. [1] Centrifugal governors were used to regulate the distance and pressure between millstones in windmills since the 17<sup>th</sup> century. Early stem engines employed a purely reciprocating motion, and were used for pumping water an application that could tolerate variations in the working speed. It was not until the Scottish engineer James Watt introduced the rotative steam engine, for driving factory machinery, that a constant operating speed became necessary. Between years 1775 and 1800, Watt, in partnership with industrialist Mathew Bolton, produced some 500 rotati-vebeam engines. At the heart of these engines was Watt self designed “conical pendulum” governor: a set of revolving steel balls attached to a vertical spindle by links and arms, where the controlling force consists of the weight of the balls. Building on Watt design was American engineer Willard Gibbs who in 1872 theoretically analyzed Watt’s conical pendulum governor from a mathematical energy balance perspective. During his graduate school years at Yale University, Gibbs observed that the operation of the device in practice was beset with the disadvantages of sluggishness and a tendency to

overcorrect for the changes in speed it was supposed to control. The objective our investigation to increase the minimum speed of the Watt Governor from 60-80 r.p.m by extending lower arm to the down side from the intersection of upper and lower arm position and fly ball position, and noted that how the minimum speed will changes in different positions of fly ball weight.

## II. MODIFICATION OF WATT GOVERNOR

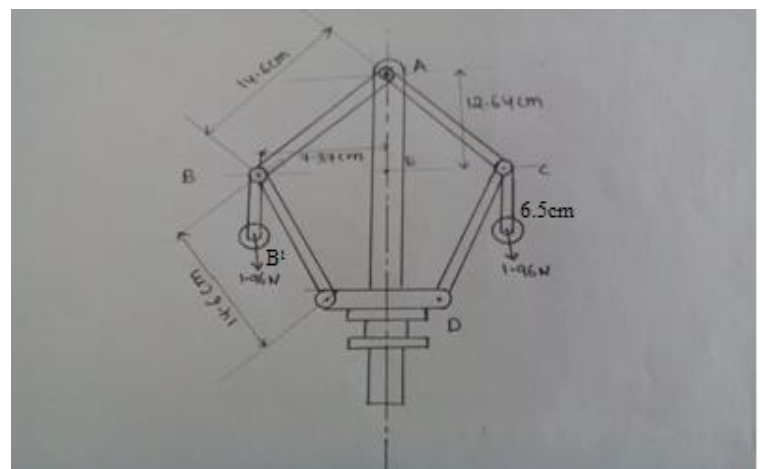


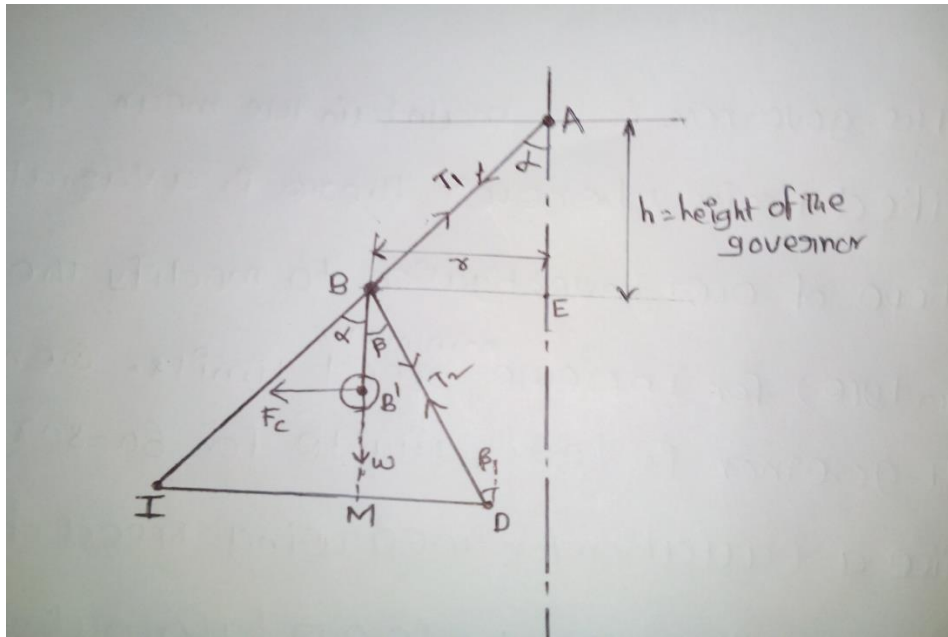
Fig. 2.1: Modification of Watt Governor [1]

[2] It consists of a pair of two balls which are attached to the spindle with the help of links and arms .the upper links are pinned at ‘A’ and lower arms are fitted to the sleeve.

Which is similar to the watt governor, but it differs from Watt Governor in the arrangement of fly balls .the fly balls are carried on the extension of lower arm to the downside from the intersection of upper links and lower arms, instead of at junction of upper and lower arms. The action of this Governor is similar to watt governor.

### 2.1 FROM INSTANTANEOUS CENTER METHOD

In this method, equilibrium of the forces acting on the link BD is considered. The instantaneous centre ‘I’ lies at the point of intersection of AB produced and a line through D perpendicular to the spindle axis, as shown in figure. 2.2



**Fig. 2.2: Instantaneous Centre Method**

Now taking moments about 'I'

$F_c \times B'M - w \times IM = 0$ , Where  $F_c = m \omega^2 r$ ,  $w = mg$  and  $IM = r$ ,  $\omega = 2\pi N/60$

$$m \omega^2 r \times B'M - mg \times r = 0$$

$$m \omega^2 r \times B'M = mg \times r$$

$$\omega^2 \times (BM - BB') = g$$

$$\omega^2 = \frac{g}{BM - BB'}$$

$$N^2 = \frac{895}{BM - BB'}$$

[1] As shown in fig. 2.1. Here AB- length of the arm (cm), BE = r = Radius of rotation (cm), AE = h = Height of the governor (cm),  $30^\circ = \alpha =$  Angle of inclination, BB<sup>1</sup>-Length of extension of lower arm, Length AB = 14.6 cm = 146 mm, BE = 7.37 cm = 73.7 mm, BB<sup>1</sup> = 6.5 cm = 65 mm, Height of the governor WKT  $h_1 = AB \times \cos \alpha = 14.6 \times \cos 30^\circ = 12.64 \text{ cm} = 0.126 \text{ m}$

**For minimum speed (N<sub>1</sub>)**

$N_1^2 = \frac{895}{BM - BB'}$  Where BM = AE = h<sub>1</sub> = 12.64 cm = 0.126 m and BB' = 6.5 cm = 0.065 m.

$$N_1^2 = \frac{895}{0.126 - 0.065} , N_1 = 121.2 \text{ r.p.m} \text{ ----- (1)}$$

**For maximum speed (N<sub>2</sub>)**

Assume sleeve to be lift 20 mm

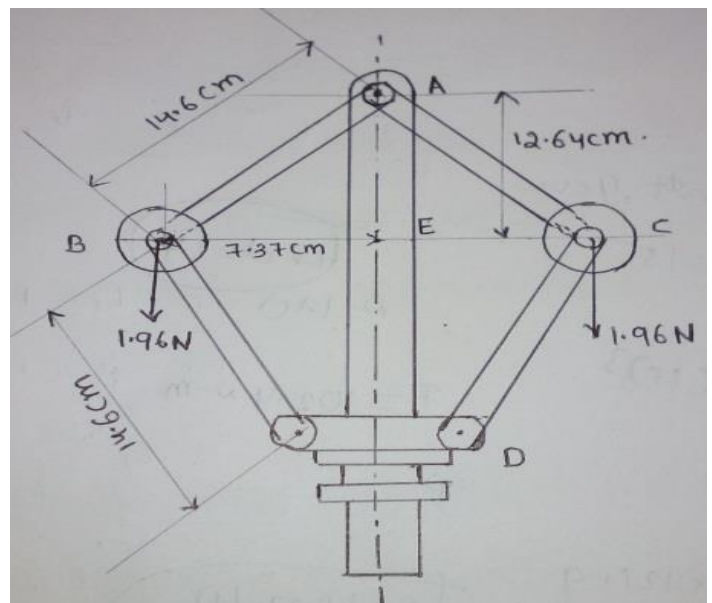
$$h_2 = h_1 - 0.02 = 0.126 - 0.02 = 0.106 \text{ m}$$

$$N_2^2 = \frac{895}{0.106 - 0.065} , N_2 = 147 \text{ r.p.m.}$$

The range of speed of the governor is  $N = N_2 - N_1 = 147 - 121.2 = 25.8 \text{ r.p.m}$

If we take the length of extension link (i.e. BB<sup>1</sup>) more than 65mm, it had some structural problem may happened and also below that length it gives < 120 r.p.m, minimum speeds.

**2.2 In a Watt Governor**



**Fig. 2.3: Watt Governor [1]**

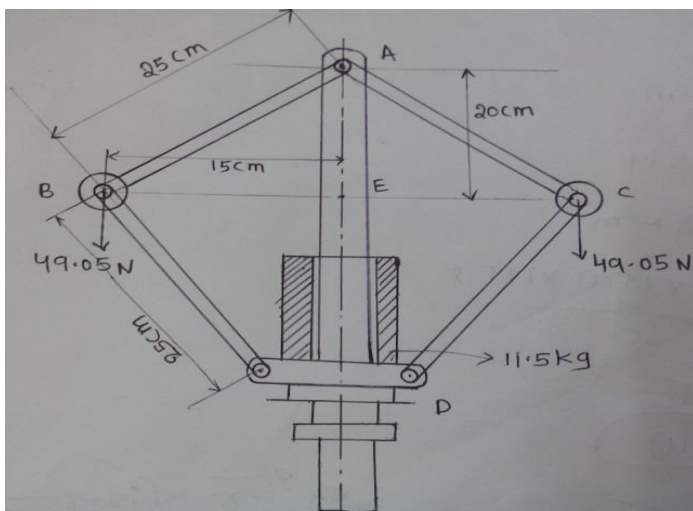
Here AB- length of the arm (cm), BE = r = Radius of rotation (cm), AE = h = Height of the governor (cm),  $30^\circ = \alpha =$  Angle of inclination, Length AB = 14.6 cm = 146 mm, BE = 7.37 cm = 73.7 mm, Height of the governor We Know That,  $h_1 = AB \times \cos \alpha = 14.6 \times \cos 30^\circ = 12.64 \text{ cm} = 0.126 \text{ m}$

**Minimum speed:**  $N_1^2 = \frac{895}{h_1} = \frac{895}{0.126}$  ,  
 $N_1 = 84.2$  r.p.m. ----- (2)

Assume sleeve to be lift 20 mm,

Maximum speed:  $N_2^2 = \frac{895}{h_2} = \frac{895}{0.108}$  ,  
 $N_2 = 91.77$  r.p.m.

### 2.3 In a Porter Governor



**Fig .2.4: Porter Governor [2]**

Here AB- length of the arm (cm), BE = r = Radius of rotation (cm), AE = h = Height of the Governor (cm),  $30^\circ = \alpha =$  Angle of inclination, Mass of Fly ball (m) in Kg's,

Mass of Central Sleeve (M) in Kg's, Length AB = 25 cm= 250 mm , BE = 15 cm =150 mm , Height of the Governor We Know That ,  $AB^2 - BE^2 = h^2$  ,  $25^2 - 15^2 = h^2$  ,  $h_1 = 20$  cm = 0.2 m and  $m = 5$  Kg,  $M = 11.5$  Kg, For **minimum speed:**

$N_1^2 = \frac{m+M}{m} \times \frac{895}{h_1} = \frac{5+11.5}{5} \times \frac{895}{0.2}$  ,  $N_1 = 121$  r.p.m.----- (3)

From comparing equations 1, 2, 3 we observed that how the minimum speed of the governor will changes.

### III. RESULTS AND DISCUSSIONS

- I. The small modification of Watt Governor will give better results in operating speed limits. We have been fabricated this governor in our laboratory and observed working of this governor.
- II. Generally we seen that the Watt Governor is suitable for lower speeds only (i.e. 60-80 r.p.m), but by small modification it can also used for above the lower speeds (i.e. 120 -130 r.p.m).
- III. The modification of Watt Governor will may replace the porter governor some extent
- IV. In generally To maintain 120r.p.m minimum speed by porter governor it needs 250mm arm lengths, 5kg fly ball weight, 11.5kg central sleeve load. but by small modification of

Watt Governor it needs only 146mm arm lengths, 0.126 kg fly ball weight and no central sleeve load.

- V. So that to maintain 120r.p.m with modified Watt Governor, it minimizes the arm lengths, weight of the fly balls, central sleeve loads when compare with Porter Governor.

### IV. FUTURE SCOPE

- i. Analysis of Stress concentration on various elements of the governor which minimizes the failures.
- ii. Analysis on different materials for sleeve, spindle and arms.
- iii. Vibration analysis will give better results in accuracy.
- iv. Study on various factors (i.e. stability, sensitivity, and hunting) of the governors.

### V. CONCLUSIONS

- i. Modification of Watt Governor gives better results when compare with Watt and Porter Governor.
- ii. To study the effect of extension of lower arm on variation in minimum speed of the governor
- iii. To maintain 120 r.p.m, minimum speeds by Porter Governor it needs 250mm arm lengths, 5kg fly ball weight, 11.5kg central sleeve load whereas modified Watt Governor needs only 146mm arm length, 0.126kg fly ball weight and no central sleeve load.

### ACKNOWLEDGEMENT

We are thanking to our teaching and non teaching members in our college (i.e. S.V.E.C, Suryapet). Giving their valuable support and time.

### REFERENCES

- [1] IJSRP, Volume 2, Issue 6, June 2012 ISSN 2250-3153
- [2] A TEXT BOOK OF THEORY OF MACHINES, Fifth Edition by Dr. R.K. Bansal and Dr. J.S. Bra, with Laxmi Publications (P) L.t.d.
- [3] THEORY OF MACHINES, Third Edition by S S RATTAN, with Tata McGraw Hill Education (p) L.t.d.
- [4] WWW.ANSWERS.COM/TOPIC/GOVER-DE
- [5] HTTP//EN.WIKIPEDIA.ORG/WIKI/GOVER-DE.

### AUTHORS

**First Author-** GiriBabu Surarapu, M Tech (Machine Design) SIT, Khammam, Telengana, India, Email: [giribabuglory@gmail.com](mailto:giribabuglory@gmail.com)

**Second Author-** Shashidar PeddiReddy, M Tech (Machine Design) KITS, Khammam, Telengana, India. Email: [psr326@gmail.com](mailto:psr326@gmail.com)

**Third Author-** Nagamani Uotkuri, M.Tech (cad cam), Department of mechanical Engineering S.V.E.C, Suryapet, Nalgonda, Telengana, India, Email: [glorygiribabu@gmail.com](mailto:glorygiribabu@gmail.com).

**Correspondence Author-** GiriBabu Surarapu,      Email:  
[giribabuglory@gmail.com](mailto:giribabuglory@gmail.com), mobile: 8125590627.

# Students' Residential College Assessment through User Experience as a Component of Service Excellence

Musa Alkali Abubakar\*, Rozilah Kasim\*, Matthew Mamman\*\*

\*Faculty of Technology Management, Business  
Universiti Tun Hussein Onn Malaysia  
86400 Parit Raja Batu Pahat Johor  
Malaysia

\*\*Department of Estate Management, Kaduna Polytechnic, Nigeria.

**Abstract-** In competitive educational environment where international students have many choices available, attributes that enable higher learning institutions to attract and maintain more international students should be studied seriously. Understanding the experience of international students during service delivery is vital for achieving service excellent. The aim of the study is to assess international students' experience on the facilities provided at UTHM students' residential colleges. The study identified the existing level of physical attributes that influence international students' experience in the study area. The study used face to face survey. Questionnaires were distributed to 210 international students at UTHM students' residential colleges. However, 189 responses were collected. The data was analyzed using SPSS from which descriptive statistics data was obtained. The existing levels of physical attributes identified include the availability, comfortability and quality of the physical attributes. The finding of this study helps to formulate guidelines in terms of improvement, maintenance, design and construction for future developments of students' residential colleges in order to achieve service excellence.

**Index Terms-** students' residential college, service user experience, service excellence, physical attributes, international students.

## I. INTRODUCTION

Presently higher institutions of learning are trying to attract more number of international students in their own programs and employing various strategies to maintain them [1]. The introduction and the delivery of customer value become important in creating a sustainable advantage in the highly competitive education market [2]. Moreover, in today's higher learning arena, international students have been described as a special commodity, and some countries like Australia, the United States and Britain has put in place some methods which aimed at attracting them [3]. However, in Asian region, some countries have expressed their intention of becoming education hubs of higher learning in the region, and leading the initiative are countries in the East Asia region, namely Singapore, Hong Kong and Malaysia [4]. According to the Ministry of Higher Education, Malaysia has two (2) percent of the world's international student population, as of 2009 and was ranked the world's 11th most preferred study destination. However in 2010, the total enrolment of international students in public and private higher learning institutions have increased from 40,525 in the year 2005, to 80,750 students, in the year 2009 [5]. Therefore, Malaysia has become a strong force in international education and thus they need to examine and understand how these students fit into and perceive the service delivered and physical environment of their higher institutions of learning [6].

According to Sirat, the enrolment of international students has increased gradually in Malaysia since 1996, when numerous higher educational transformations were introduced to facilitate the entry of international students into Malaysian higher learning institutions [7]. The National Mission and 9th -10th Malaysia Plans set out the country's vision of moving Malaysia into a high-income knowledge-based economy by 2020. The National Higher Education Strategic Plan (NHESP) was formulated with a vision to transform higher education within the context of establishing Malaysia as an international hub of excellence for higher education [7]. More so, the target of NHESP is to have the total number of 200,000 international students by the year 2020 [5]. It can be understood that there is a provision to accommodate this expansion from now to 2020 based on the internationalization policy for higher education in Malaysia which aimed at accelerating the inflow of international students to 150,000 by 2015 [8]. Moreover, University Tun Hussein Onn Malaysia (UTHM) is among the higher institutions in Malaysia that have witnessed an increase in the number of international students. According to the UTHM International office, the number of international students increased from seventeen (17) students, in 2007 to four hundred and ninety three (493) students in 2014.

User experience refers to different areas of relationship with user including experience with continuing business relationship, experience with the quality of service, experience with the performance ratio of a service and experience because a service met users' expectation [9]. The most significant part of problem solving is to understand the whole structure of user requirements and needs. The



needs of user must be examined independently [10]. Similarly in facilities management, full users' complaints must be recorded accordingly into an integrated maintenance schedule which is transparent, reliable and dependable [11]. Service providers in facilities management should be proactive in finding out the users' needs and wants, and the most important aspect in achieving that goal is through communication [12]. Bashir opined that users' needs should be fully incorporated into the design and development of products and services, especially in students' residential colleges [13].

Student residential college is a supervised living-learning accommodation consisting of shared residential amenities and facilities for the community of residents, which is constructed on-or off campus, and owned or rented by higher institution of learning. It provides low-cost chargeable rooms, and administered to accommodate the undergraduate or postgraduate students [14]. According to Najib et al., student residential colleges have been introduced to provide relatively low-cost, sanitary, safe and comfortable living environment to promote the social, personality, intellectual, physical, carrier, educational and moral development of those who live there [15]. Moreover, student residential colleges has been described as an essential component of the facilities provided by higher institutions of learning in helping students to expand their intellectual competence [16]. Physical attributes of students' residential college, such as architectural design, bedroom size, floor level and density can influence students' experience [17].

The main objective of this study is to determine the existing level of physical attributes that influence service user's experience with the facilities provision in the study area. The overall aim is to assess the service user's experience on the physical attributes of the facilities provided at the UTHM students' residential colleges.

## II. LITERATURE REVIEW

Service is an economic activity that creates value and delivers benefits to users at precise times and places by bringing about anticipated change on behalf of the recipients of the service [18]. According to Johnston & Clark, service is a combination of outcomes and experiences delivered to and received by a user, they further explained that users judge the quality of service on the experience as well as the outcome [19]. As services and products are becoming more similar and as it becomes easier for organizations to copy others' they may decide to compete through something that exceeds their service offering. The service concept, relates with the characteristics of the service offered to the target market [20]. He further described the service concept as the bundle of goods and services sold to users. The dominant opinion is that, service concept can be seen as a bundle made up of a set of tangible and intangible elements. Similarly, service is defined in terms of its constituent parts and the most common way of classifying the service concept relates to the degree of customization of these elements [19].

The evolution of service concepts involved two important dimensions; commoditization and customization. Customization means producing in response to a particular user desires. Customization handles the individual user request. Organizations should modify product and services to meet the exceptional needs of individual service users in such a way that nearly all can find exactly what they want at a reasonable price through a new mind-set, one of creating service user unique value, while commoditization on the other hand, refers to the regulation process, that is, it prescribes whether the service delivery has been performed to the needs of every individual user [21]. Moreover, commoditization refers to the description process of a service, where it describes the steps to be followed so that a particular service gets delivered. It also deals with the way in which the request of the individual user is packaged [22].

### A. Service User Experience

In the marketing literature, experiences are regularly used to refer to a definite group of services including travel, music, theatre, restaurants, hotels and culture. The basis of these services has to do with hedonic consumption [23]. Meyer & Schwager, define service user experience as the internal and subjective response, users encounter to any contact, direct or indirect with organization [24]. User experience is a holistic concept that involves every aspect of organization's offering [25]. Service user experience is defined as the service process that creates the user's cognitive, emotional and behavioral responses which result in a mental mark, a memory [17].

The concept of experience is also used to add value to user services, for example in telecommunications services, educational services, residential college services and airline services. Ritz Carlton and Singapore Airlines, for example, focus not only on traditional service quality issues and factors such as reliability and assurance, but also on creating favorable user experiences [26] (Pariag, 2009). Some service user experiences are favorable and some are not both tend to stay in the user's memory. These experiences will have a strong impact on user's perceptions.

### B. Factors Affecting Service User Experience

Service user experience has been described as an internal and subjective response, users encounter to any contact, direct or indirect with an organization. User experience is a holistic concept that encompasses every aspect of organization's offering [27]. Khozaei et al., described students' residential colleges, as a densely building with many rooms in which each room contain several beds [28]. Thus students residential colleges provides sleeping and living quarters, usually without private baths, for a large number of students and such residential college is furnished and rented by bed. However, provision of student residential facilities is one of the

major issue students will consider in choosing a higher institution of learning [15]. Consequently, if Higher Institutions of Learning fail to provide adequate and suitable residential facilities for students, students may face increase pressure, and lack of affordable off-campus residential colleges may create a significant inconvenience. Therefore, students will give high priority to institutions that provide suitable and adequate facilities in their residential colleges [29]. Students residential facilities can fulfill various needs and will provide rooms that are equipped with complete facilities and services, the space will also encourage friendship and provide friendly learning environment [30].

Factors affecting service user experience may include convenience, choice, age, value adding and life, speed of service delivery, quality and technology. However some of these factors may not necessarily apply to all higher institutions, even though some common factors can be shared [31]. There are various factors that influence students experience with their residential colleges, which include physical and, demographic attributes [32].

### *K. Physical Attributes*

Physical attributes of residential college, such as architectural design, bedroom size, floor level, density, building layout, bathroom, laundry room, study area, internet facilities and security guards can influence students experience in residential colleges [15]. More so, [27] opined that physical attributes in residential college, such as architectural design, support services; space and location on campus also have influence on students' experience with their residential college. He further added that light, temperature, noise and air quality also has powerful influence over experience with residential college. Moreover excessive noise has been rated as a significant detractor from student experience. According to [25] prolonged exposure to noise and very high noise level during sleep may cause hearing loss, mental stress and irritation. Quietness is the most important requirement in any residential college. Some of the physical attributes that influence service users' experience are discussed as follows:

**Study-bedroom:** study bedroom has to enable some functions in a reasonably small space; these may include studying, sleeping, eating, socializing and relaxing. The study bedroom must provide privacy and security, with good lighting and ventilation, and a reasonable view; more so, student should be able to control his internal environment such as heating, cooling, lighting and should be able to impose his own personality in the room without causing any damage [33]. Moreover, study bedroom is an important component that must be provided in all residential colleges, it is a multipurpose room that combined study, living and sleeping facilities [34].

**Density:** is defined as the number of person per structure and is identified as another physical factor that influence students experience with residential college [1]. They further added that, users of triples shows greater feelings of crowding and perceive less control over room activities, expressed more negative inter personal attitudes and experience more negative room atmosphere

**Floor Level;** [35] on students' residential college settings, opined that students living at the upper floors, perceived larger rooms and found them not crowded compared with those on the lower floor. Floor level could influence students' experience and friend formation. Users of single-story residence hall were significantly more satisfied and establish more residence base friendship than users of multistory residential hall.

**Privacy:** According to [35] increase in the level of students' experience with residential college depends on the students' perception of their privacy. Moreover, [34] opined that female students were most likely to stay in shared residential facilities while their male counterpart preferred to stay in more private place.

The student residential college should be isolated from sources of noise. The level of noise can affect students' attention for studying and privacy of communication. In residential college facilities, noise mostly originates from aircraft, traffic, construction sites and activities in the neighborhood [34]. However, very high noise levels, prolonged exposure to noise during sleep may cause irritation, mental stress and hearing loss [29]. Quiet is the most required requirement in any living arrangement in the opinion of students. Primary to providing quiet environment are walls, floors, windows and doors providing adequate reduction of sound from adjacent activities [19].

**Fire safety equipment:** Fire outbreak causes loss of life and property in buildings. Student residential college is a typical type of buildings that house a large number of users. More so, student residential facilities are vulnerable because of their high fire load. Fire load is defined as the amount of fuel within a room or a building, which will burn to release heat and feed the growth of fire [36].

**Interior and exterior finish systems:** The building components that users interact with include external walls, internal finishes and floor surfaces. Common performance problems associated with external walls include color fading, moisture and wind infiltration, buckling, cracking, cleanability and erosion [37]. Moreover, the performance standards for internal finishes including floors, ceilings and walls emphasize aesthetic attributes such as fading, evenness of surfaces and cleanability. Furthermore, durability of floor surfaces refers to resistance to scratches, indentations, abrasions, spills, stain and cigarette burns [38].

**Furniture:** Typical provision of furniture in the study bedroom includes bed, desk, chest of drawers, closet, shelving and chair [16]. As the student buying ability increases, the requirement for additional storage facilities for a variety of things and personal belongings such as clothes, electronic sets and sports equipment. Some of these storage facilities should be lockable for permanent storage during student absence from the room, for short or long time and the rest can be simple cabinets [37].

**Efficiency of circulation:** According to [40] the internal layout of the students' residential college building should be effective in terms of the arrangement of study bedrooms in each floor, the width of the corridors for circulation inside the building and the number and location of staircases in the building. Moreover, the building layout should encourage social interaction among the student population. Visitors should be able to easily locate study bedrooms in the building [41].

**Proximity to other facilities on campus:** According to [16] student residential college facilities should be located in reasonable proximity (i.e. within short waking distance) to teaching, recreational centers, cafeteria, parking facilities, mini market, health facilities and public transportation.

**Visual comfort:** The optimal design of lighting in the residential colleges, involves providing a comfortable and healthy visual environment that supports the activities of users. The benefits of achieving lighting comfort include providing enough light to permit safe accomplishment of tasks; avoid eye strain and headaches; and improve social interaction [42]. Electrical lighting should not compensate for natural daylight in student residential colleges. The window size must allow sufficient light and electrical lighting must provide for comfortable reading conditions at the desk, in bed and in the armchair. Moreover, general lighting should be enhanced by task lighting to serve desk, chair and bed positions [43].

**Provision of ventilation:** Indoor air quality is an important essential of a pleasurable and productive indoor environment. Building users with indoor air quality problems suffer from symptoms such as eye, nose and throat irritation, dry skin and mucous membranes, fatigues, headache, wheezing, nausea and dizziness resulting in discomfort [44]. The benefits gained from achieving an acceptable indoor air quality include: providing enough air exchanges to avoid lack of oxygen; filtering air to avoid particles which cause respiratory ailments; and providing enough air exchanges to rid areas of odors such as smoke [37].

**Support services:** Toilet/bathrooms, showers and water closets are generally designed to the minimum practical area and must be close proximity to all study bedrooms. Students are not often careful in the way they use the facilities; overflowing and leaking showers are common problems [16]. Good ventilation should be provided in the study bedrooms to reduce the effects of condensation problems. However, it is important that all external materials used in the toilet/bathroom should have moisture-resistance finishes [45]. Waste disposal and water supply systems should be properly installed, maintained and managed. A laundry with washing and drying machines should be provided. A sink for hand-washing clothes and facilities for ironing and folding clothes should be provided with maintenance of fittings and equipment. Since laundries can be noisy, smelly and humid, their locations should be carefully selected. They should be provided with good lighting, ventilation to remove moisture and odor and a floor gully. Services such as electricity supply and hot water must be adequate for the level of use [46].

### *C. The Concept of Service Excellence*

The continuous globalization of services has prompted organizations in various service industries to concentrate on achieving user delight through service excellence, which will enable them to secure their competitive position and establish long-term user relationship [47]. They also added that service excellence occurs when users perceive that a service exceeds their previous expectations. Similarly, service excellence could be described as that which the user perceives as providing the services they need quickly, conveniently without any error and delivered politely by knowledgeable staff at an acceptable cost [48]. More so, the provision of excellent services is central to the competitive strategies of most, if not all service organizations. Particularly, issues related to service quality in higher institutions have led to an increased awareness of the significance of internal user satisfaction [49]. The challenges and benefits of service excellence are emphasized as previous research shows that users and other stakeholders' expectations are growing and that the demand in better returns for their investment in higher institutions of learning are increasing [50]. As a result, service excellence is becoming a major component of higher education institutes' (HEIs') which they struggle to accomplish and maintain sustainable competitive advantage. Service excellence is an integral part in higher education delivery; various employees came into contact with a range of internal and external stakeholders and are directly responsible for the provision of quality services provided to their students [50]. They further stated that, in order to deliver the best service and to gain competitive advantage, HEIs should recruit, train and develop highly motivated and committed employees.

## III. METHODOLOGY

The face to face survey was employed in this study, where data was collected only from international students, who are studying and living in five out of the seven students' residential colleges in UTHM. The residential colleges under study include, Kolej Kediaman Melewar, Kolej Kediaman Taman University, Kolej Kediaman Tun Syed Nasir, Kolej Kediaman Perwira and Kolej Kediaman Kelisa. A random sample of 210 international students was drawn from the residential population, using stratified random sampling technique. Stratified random sampling was adopted because it obtains estimates of known precision for certain subdivisions of the population by treating each subdivision as a stratum [51]. The total number of questionnaires distributed to the targeted population of international students living in five UTHM students' residential colleges, that served as the base for the data analysis was 210, However, 189 questionnaires were returned representing 90%. The questionnaires were distributed face-to-face to the targeted respondents in the study area where 5-point Likert scale was used with neutral choice. Moreover, reliability analysis was conducted for the scaled answers and the scale shows a good internal consistency, with cronbach's alpha coefficient ranging from 0.895, 0.861 and 0.877.

The background of the respondents is very important, as shown in Table 1, it disclose the gender, age, religion, race/nationality, marital status, economic status, level of study and duration of staying of the respondents. Out of 189 international students, 169

respondents representing 89% are males while 20 respondents representing 11% were females. The age distribution of the respondents ranges between 20-25 (53%), 26-30 (24%), 31-35 (10%) and 35 and above (12%). Religion of the respondents shows that 179 respondents representing 95% are Muslims, 8 respondents representing 2% are Christians while only 2 respondents representing 1 respondent came from other religion. Marital status of the respondents, single 63%, married 36% and divorced 1%. Race/nationality of the respondents is classified as Arab 50%, Africans 33%, Pakistan 10%, Indian 2% and others 5%. The respondents' level of study also is classified as undergraduate 45%, masters 31% and PhD 24%. Duration of staying shows that 50% stayed less than 1 year, 38% between 1- 2 years, while 12% between 3-4 years.

Table 1: Respondents demography

Attributes	classification	Frequency	Percentage (%)
Gender	Male	169	89
	Female	20	11
Age	20-25	100	53
	26-30	46	24
	31-35	19	10
	36 & above	23	13
Religion	Islam	179	95
	Christian	8	4
	Others	2	1
Race/nationality	Arab	95	50
	African	63	33
	Pakistan	19	10
	Indian	3	2
	Others	9	5
Marital status	Single	119	63
	Married	68	36
	Divorce	2	1
Economic status	Parent	71	38
	Scholarship	56	30
	Student loan	27	14
	Others	35	18
Level of study	Undergraduate	85	45
	Masters	58	31
	PhD	45	24
Duration of staying	Less than 1 year	94	50
	1-2 years	71	38
	2-3 years	24	12

#### IV. ANALYSIS AND FINDINGS

A detailed descriptive analysis of service user's experience with the facilities provision at UTHM students' residential college is presented using SPSS (Version 20). The study identifies the opinion of service users on the existing level of physical attributes at UTHM students' residential colleges. Moreover, three existing levels of physical attributes considered in this research were the availability, comfortability and the quality of the existing physical attributes. In this regards, questions were presented to the respondents which describe various level of the existing physical attributes. The five Likert scale approach was used to rate the answers, whereas five choices were defined. These ranged from 'one' as the most negative answer, to 'five' as the most positive answer. The results of this analysis are shown below. It is important to note that all percentages were rounded to the nearest figure.

##### A. Experience of service users on the availability of the physical attributes at UTHM students' residential colleges

This section determines the existing level of physical attributes that influence service users' experience with the facilities provision at UTHM students' residential colleges. To determine the availability of the existing physical attributes, the mean calibration proposed by Hassanain, (2008); Najib et al., (2011) was adapted, the mean results were validated and the following scale of 1-5 was used.

- The physical attribute is extremely adequate if the mean score is between 4.5 and 5.
- The physical attribute is adequate if the mean score is between 3.5 and 4.49.
- The physical attribute is fairly adequate if the mean score is between 2.5 and 3.49.
- The physical attribute is inadequate if the mean score is between 1.5 and 2.49.
- The physical attribute is extremely inadequate if the mean score is less than 1.49.

From the data analysis, as illustrated in Table 2, the findings revealed that space in the Mosque, safe living environment, building security, security guards and perimeter fence were ranked adequate as their mean score fall within the range of 3.70 to 3.81. However, some variables were ranked fairly adequate by their mean falling within the range of 2.5 to 3.49, such as cooling/heating

facilities in study bedroom, adequate storage facilities in study bedroom pantry/kitchen, sport facilities, cross ventilation in study bedroom, natural/artificial lighting, privacy, emergency exit, high level of privacy, firefighting equipment's, burglary proof, toilet facilities, number of people sharing toilet, study area, internet facility in the study area, parking space, cafeteria/restaurants, laundry facilities and waste disposal. While net on windows in the study bedrooms was ranked inadequate as the mean score fall within the range of 1.5 to 2.49.

Table 2: Experience of service users on the availability of existing physical attributes (Field Survey 2014)

Availability of Physical attributes		1	2	3	4	5	Mean score	Level of availability
<b>Study Bedroom</b>	Adequate storage facilities in study bedroom	15 (8%)	44 (23%)	52 (27%)	60 (32%)	18 (10%)	3.12	Fair
	Natural artificial lighting in study bedroom	13 (7%)	28 (15%)	48 (25%)	73 (39%)	27 (14%)	3.39	Fair
	Cross ventilation in study bedroom	22 (12%)	52 (27%)	49 (26%)	46 (24%)	20 (11%)	2.95	Fair
	High level of privacy in study bedroom	24 (13%)	42 (22%)	49 (26%)	44 (23%)	30 (16%)	3.07	Fair
	Net on windows in study bedroom	61 (32%)	48 (25%)	39 (21%)	27 (15%)	14 (7%)	2.39	Fair
	Cooling/heating facilities in study bedroom	53 (28%)	52 (27%)	34 (18%)	36 (20%)	14 (7%)	2.50	Fair
<b>Building layout</b>	Emergency Exit	19 (10%)	33 (18%)	36 (19%)	76 (40%)	25 (13%)	3.29	Fair
	Firefighting equipment's	16 (8%)	24 (13%)	40 (21%)	79 (42%)	30 (16%)	3.44	Fair
<b>Toilet/bathroom</b>	Toilet Facilities	25 (14%)	31 (16%)	50 (26%)	64 (34%)	19 (10%)	3.11	Fair
	Number of people sharing toilet/bathroom	16 (7%)	55 (31%)	46 (24%)	54 (29%)	18 (9%)	3.02	Fair
<b>Study area</b>	Study area facilities	18 (9%)	31 (16%)	38 (20%)	75 (40%)	27 (15%)	3.33	Fair
	Internet facility in the study area	33 (17%)	25 (13%)	39 (21%)	69 (37%)	23 (12%)	3.13	Fair
<b>Mosque</b>	Adequate space in the Mosque	9 (5%)	10 (5%)	46 (24%)	67 (36%)	57 (30%)	3.81	Adequate
<b>Security</b>	Safe living environment	13 (7%)	18 (9%)	25 (13%)	86 (46%)	47 (25%)	3.72	Adequate
	Security guards	7 (4%)	12 (6%)	41 (22%)	77 (41%)	52 (27%)	3.82	Adequate
	Building security	8 (4%)	16 (8%)	45 (24%)	75 (40%)	45 (24%)	3.70	Adequate
	Perimeter fence	8 (4%)	16 (8%)	45 (24%)	75 (40%)	45 (24%)	3.53	Adequate
	Burglary proof	17 (9%)	47 (25%)	49 (26%)	43 (23%)	33 (17%)	3.15	Fair
<b>Support Services</b>	Enough parking space	21 (11%)	38 (20%)	60 (33%)	52 (27%)	18 (9%)	3.04	Fair
	Sport facilities	33 (17%)	37 (21%)	53 (28%)	48 (25%)	18 (9%)	2.90	Fair
	Adequate waste disposal	13 (7%)	21 (11%)	54 (29%)	69 (36%)	32 (17%)	3.46	Fair
	Cafeteria/mini market	13 (7%)	21 (11%)	54 (29%)	69 (36%)	32 (17%)	3.46	Fair
	Laundry facilities	21 (11%)	22 (12%)	49 (26%)	68 (36%)	29 (15%)	3.33	Fair
	Pantry/kitchen	48 (25%)	45 (24%)	44 (24%)	35 (18%)	17 (9%)	2.62	Fair

Note: 1= Extremely adequate, 2= Inadequate, 3= Fairly adequate, 4= Adequate, 5= Extremely adequate

*B. Experience of service users on the comfortability of the existing physical attributes at UTHM students' residential colleges*

To determine the comfortability of the existing level of physical attributes in UTHM students' residential colleges, the mean calibration proposed by Hassanain, (2008); Najib et al., (2011) was adapted, the mean results were validated and the following scale of 1-5 was used.

- a). The respondents were extremely comfortable with the existing physical attribute if the mean score is between 4.5 and 5.
- b). The respondents were comfortable with the existing physical attribute if the mean score is between 3.5 and 4.49.
- c). The respondents were neither comfortable nor uncomfortable with the existing physical attribute if the mean score is between 2.5 and 3.49.
- d). The respondents were not comfortable with the existing physical attribute if the mean score is between 1.5 and 2.49.
- e). The respondents were extremely not comfortable with the existing physical attribute if the mean score is less than 1.49.

As shown in Table 2, the findings revealed that, the service users' were neither comfortable nor uncomfortable with some variables as their means score fall within the range of 2.5 to 3.49 such as, the study bedroom size, furniture in the study bedroom, conducive living environment, proximity of the residential college to university, proximity of the residential college to health facilities, proximity of residential college to public transportation, proximity of residential college to restaurants, proximity of residential college to ATM machine, proximity of residential college to mini market, proximity of residential college to recreational centres, proximity of residential college to waste collection centers and proximity of residential college to local shops.

Table 2: Experience of service users on the comfortability of the existing physical attributes (Field Survey 2014)

Comfortability of physical attributes		1	2	3	4	5	Mean	Level of comfortability
Study bedroom	Study bedroom size	27 (14%)	37 (20%)	51 (27%)	52 (27%)	22 (12%)	3.03	Neutral
	Furniture in the study bedroom	20 (11%)	55 (29%)	47 (25%)	49 (26%)	18 (9%)	2.95	Neutral
Security	Conducive living environment	15 (8%)	26 (14%)	73 (38%)	64 (34%)	11 (6%)	3.16	Neutral
Location	Proximity of residential college to University	22 (12%)	31 (16%)	44 (23%)	66 (35%)	26 (14%)	3.23	Neutral
	Proximity of residential college to health facilities	15 (8%)	35 (18%)	54 (29%)	66 (35%)	19 (10%)	3.21	Neutral
	Proximity of residential college to public transportation	19 (10%)	27 (14%)	60 (32%)	63 (33%)	20 (11%)	3.20	Neutral
	Proximity of residential college to restaurants	21 (11%)	29 (15%)	48 (26%)	65 (34%)	26 (14%)	3.24	Neutral
	Proximity of residential college to ATM machine	25 (13%)	48 (25%)	41 (22%)	49 (26%)	26 (14%)	3.02	Neutral
	Proximity of residential college to mini market	19 (10%)	42 (22%)	60 (32%)	51 (27%)	17 (9%)	3.03	Neutral
	Proximity of residential college to recreational centers	24 (13%)	40 (21%)	60 (32%)	48 (25%)	17 (9%)	2.97	Neutral
	Proximity of residential college to waste collection centers	19 (10%)	32 (17%)	52 (27%)	63 (34%)	23 (12%)	3.21	Comfortable
	Proximity of residential college to Local shops	12 (6%)	31 (16%)	43 (23%)	81 (43%)	22 (12%)	3.37	Comfortable

Note: 1= Extremely not comfortable, 2= Not comfortable, 3= Neutral, 4= Comfortable, 5= Extremely comfortable

*C. Experience of service users on the quality of the existing physical attributes at UTHM students' residential colleges*

To determine the quality of the existing level of physical attributes in UTHM students' residential colleges, the mean calibration proposed by Hassanain, (2008); Najib et al., (2011) was adapted, the mean results were validated and the following scale of 1-5 was used.

- a). The quality of the physical attribute is very good, if the mean score is between 4.5 and 5.
- b). The quality of the physical attribute is good, if the mean score is between 3.5 and 4.49.
- c). The quality of the physical attribute is fair, if the mean score is between 2.5 and 3.49.
- d). The quality of the physical attribute is poor, if the mean score is between 1.5 and 2.49.
- e). The quality of the physical attribute is very poor if the mean score is less than 1.49.

As shown in Table 3, the findings revealed that Mosque location, Mosque, amenities and the cleanliness of the Mosque were ranked good by the service users as their mean score fall within the range of 3.5 to 4.49. However, some variables were ranked fair as their mean score fall within the range of 2.5 to 3.49, such as architectural design of the residential college, study bedroom design,



convenient walkway, good drainage system, toilet/bathroom location, cleanliness of toilet/bathroom, study area accessibility, internet connectivity in the study room, furniture in the study area, security of parking facilities, internet connectivity in the residential college, directional signage, directional signage are writings, cleaning services, transportation links to university and city center, transportation service (Bus) from residential college to the University and operation of bus service in weekends and holidays. While the directional signage was ranked poor as the mean score fall within the range of 1.5 to 2.49.

Table 3: Service users experience on the quality of physical attributes (Field Survey 2014)

Quality of Physical attributes		1	2	3	4	5	Mean	Quality level
<b>Building Layout</b>	Architectural design of the residential college	33 (17%)	47 (25%)	56 (30%)	41 (22%)	12 (6%)	2.75	Fair
	Study bedroom design	21 (11%)	66 (35%)	49 (26%)	47 (25%)	6 (3%)	2.74	Fair
	Convenient walkway	12 (6%)	35 (18%)	53 (28%)	74 (40%)	15 (8%)	3.24	Fair
	Good drainage system	11 (6%)	27 (14%)	41 (22%)	85 (45%)	25 (13%)	3.46	Fair
<b>Toilet/bathroom</b>	Toilet/bathroom location	25 (13%)	51 (27%)	40 (21%)	54 (29%)	19 (10%)	2.95	Fair
	Cleanliness of toilet/bathroom	21 (11%)	34 (18%)	38 (20%)	72 (38%)	24 (13%)	3.23	Fair
<b>Study area</b>	Study area accessibility	13 (7%)	30 (16%)	43 (22%)	66 (35%)	37 (20%)	3.44	Fair
	Internet connectivity in the study room	49 (26%)	49 (26%)	31 (16%)	40 (21%)	20 (11%)	2.65	Fair
	Furniture in the study area	29 (15%)	41 (22%)	45 (24%)	49 (26%)	25 (13%)	3.00	Fair
<b>Mosque</b>	Location of Mosque	12 (6%)	16 (8%)	29 (15%)	75 (41%)	57 (30%)	3.79	Good
	Mosque amenities	8 (4%)	18 (9%)	48 (25%)	64 (34%)	51 (28%)	3.70	Good
	Cleanliness of Mosque	7 (3%)	11 (6%)	34 (18%)	78 (41%)	59 (31%)	3.90	Good
<b>Support services</b>	Security of parking facilities	12 (6%)	28 (15%)	54 (29%)	70 (37%)	25 (13%)	3.36	Fair
	Internet connectivity in the residential college	50 (26%)	55 (29%)	36 (20%)	31 (16%)	17 (9%)	2.52	Fair
	Directional signage	31 (16%)	56 (30%)	50 (26%)	37 (20%)	15 (8%)	2.73	Fair
	Directional signage are written in international language	68 (36%)	55 (29%)	38 (20%)	25 (13%)	3 (2%)	2.15	Fair
	Cleaning services	48 (25%)	45 (24%)	44 (24%)	35 (18%)	17 (9%)	2.62	Fair
<b>Transport services</b>	Transportation links to university and city center	38 (20%)	20 (11%)	51 (27%)	55 (29%)	25 (13%)	3.05	Fair
	Transportation service (Bus) from residential college to the University	36 (19%)	37 (20%)	52 (27%)	40 (21%)	24 (13%)	2.89	Fair
	Operation of bus service in weekends and holidays	46 (24%)	43 (23%)	43 (23%)	35 (18%)	22 (12%)	2.70	Fair

Note: 1= Very poor, 2= Poor, 3= Neutral, 4= Good, 5= Very good

## V. CONCLUSION

In general, findings of the study reveal that, international students in the study area have a positive experience with the facilities provided in the students' residential colleges. However, most of the positive views related to the respondents experience were rated 'fair' instead of 'extremely adequate, extremely comfortable' or 'very good', therefore this is not sufficient if the intent of UTHM students' residential colleges, is moving from delivering a quality service to excellent service. Because it will contribute a complete shift of cultural change within UTHM students' residential colleges and help create service excellence as endorsed by this study.

Service user experience has a significant influence on the international students' experience, which infers that if higher learning institution of learning wants to attract more number of international students, provision of excellent service would be a good tool. Moreover, It can be concluded that provision of excellent service contribute towards increase level of service user experience and which ultimately increases conducive learning facilities and the willingness to excel in their studies. This study targets only UTHM international students, more studies should be conducted in order to get the opinion of other stakeholders like local students, residential college administrators, facility managers and university authorities. However, international students of only one higher

learning institution was considered in this study, future studies should include more higher institutions of learning that has more number of international students, so that policy making and guidelines could be derived.

#### REFERENCES

- [1] Khozaei, F., Hassan, A. S., & Khozaei, Z. (2010). Undergraduate students' satisfaction with hostel and sense of attachment to place: case study of University Sains Malaysia. *American Journal of Engineering and Applied Sciences*, 3(3), 516.
- [2] Abdullah, N. A., & Rahman, S. A. (2011). Making Strategy at a Malaysian Higher Education Institution, 22, 193–198.
- [3] Pandit, K. (2007) *The Importance of International Students on our Campuses*, yearbook of the Association of Pacific Coast Geographers.
- [4] Ministry of Higher Education Malaysia, (2013). *Operational Framework for International Student Management*, 2013. Retrieved May, 14,2013 via <http://www.mohe.gov.my>.
- [5] Ministry of Higher Education Malaysia, (2013). *Data of Public Education Enrollment as at December 2011*, 2013. Retrieved May, 14,2013 via <http://www.mohe.gov.my>.
- [6] Njie, B., Asimiran, S., & Baki, R. (2012). Perceptions of international students on service quality delivery in a Malaysian public university. *Quality Assurance in Education*, 20(2), 153–163.
- [7] Sirat, M. Bin. (2009). Strategic planning directions of Malaysia's higher education: university autonomy in the midst of political uncertainties. *Higher Education*, 59(4), 461–473.
- [8] Ministry of Higher Education Malaysia, (2011). *Internationalization Policy For Higher Education Malaysia, 2011*, 2013. Retrieved May, 14,2013 via <http://www.mohe.gov.my>
- [9] Gilbert, H., Slade, M., Rose, D., Lloyd-Evans, B., Johnson, S., & Osborn, D. P. J. (2010). Service users' experiences of residential alternatives to standard acute wards: qualitative study of similarities and differences. *The British Journal of Psychiatry. Supplement*, 53, s26–31
- [10] Vermeeren, A. P. O. S., Law, E. L., & Roto, V. (2010). User Experience Evaluation Methods : Current State and Development Needs, 521–530.
- [11] Waheed, Z., & Fernie, S. (2009). Knowledge based facilities management. *Facilities*, 27(7/8), 258–266.
- [12] Drion, B., Melissen, F., & Wood, R. (2012). Facilities management: lost, or regained? *Facilities*, 30(5/6), 254–261.
- [13] Bashir, S. (2012). Students' Perception on the Service Quality of Malaysian Universities' Hostel Accommodation, 3(15), 213–222.
- [14] Winston Jr, R. B. (1993). *Student Housing and Residential Life: A Handbook for Professionals Committed to Student Development Goals*. Jossey-Bass, Inc., Publishers, 350 Sansome Street, San Francisco.
- [15] Najib, N. U., Yusof, N. A. & Osman, N.Z. (2011b). Measuring satisfaction with student housing facilities. *American Journal of Engineering and Applied Sciences*, 4(1), 52-60.
- [16] Hassanain, M. A. (2008). On the performance evaluation of sustainable student housing facilities. *Journal of Facilities Management*, 6(3), 212–225.
- [17] Najib, N.U, Yusof N.A. & Osman, N.Z (2011c). The influence of socio economic background towards satisfaction with students' housing facilities. pp 478-483
- [18] Jumat, A. R. (2012). Stakeholder service delivery expectations of military facilities management. *Built Environment Project and Asset Management*, 2(2), 146–166.
- [19] Johnston, R. & Clark, G. (2005). *Service Operations Management: Improving Service Delivery* (2<sup>nd</sup> Ed). Prentice Hall.
- [20] Mascio, R. Di. (2007). A method to evaluate service delivery process quality. *International Journal of Service Industry Management*, 18(4), 418–442.
- [21] Pine, B. J., & Gilmore, J. H. (2011). *The experience economy*. Harvard Business Press.
- [22] Pine II, B.J. & Gilmore, J. H. (1999). *The Experience Economy: work is theatre and every business a stage*. Harvard Business Press, Boston, Massachusetts.
- [23] Sundbo, P. & Darmer, P. (Eds.). (2008). *Creating experiences in the experience economy*. Edward Elgar Publishing.
- [24] Meyer, C. & Schwager, A. (2007). Understanding customer experience. *Harvard business review*, 85(2), 116.
- [25] Teixeira, J., Patrício, L., Nunes, N. J., Nóbrega, L., Fisk, R. P., & Constantine, L. (2012). Customer experience modeling: from customer experience to service design. *Journal of Service Management*, 23(3), 362–376.
- [26] Pariag, P. (2009). Classification of Services. *Regional Symposium on Services*, pp. 15-17.
- [27] Ahmed, I. (2011). Student's Perspective of Service Quality in Higher Learning Institutions ; *An evidence Based Approach*, 2(11), 159–164.
- [28] Khozaei, F., Ramayah, T. & Hassan, A. S. (2012). A Shorter Version of Student Accommodation Preferences Index (SAPI).
- [29] Thomsen, J., & Eikemo, T. A. (2010). Aspects of student housing satisfaction: a quantitative study. *Journal of Housing and the Built Environment*, 25(3), 273–293.
- [30] Khozaei, F., Hassan, A. S., Al kodamy, K. & Aarab Y. (2014). Examination of student housing preferences, their similarities and differences. *Facilities*, 32 (11/12).
- [31] Rowley, J., (1999). Measuring total customer experience in museums, *International Journal of Contemporary Hospitality Management*, 11(6), pp. 303-308.
- [32] Foubert, J. D., Tepper, R. & Morrison, D. (1998). Predictors of student satisfaction in university residence halls. *The Journal of College and University Student Housing*, 27(1), 41-46.
- [33] Olufunke, A., & Adedoyin, O. (2012). User's Satisfaction with Residential Facilities in Nigerian Private Universities : A Study Of Covenant University 2(11).
- [34] Amole, D. (2008). Residential Satisfaction and Levels of Environment in Students' Residences. *Environment and Behavior*, 41(6), 866–879.
- [35] Kaya, N., & Erkip, F. (2001). Satisfaction in a Dormitory Building the Effects of Floor Height on the Perception of Room Size and Crowding. *Environment and Behavior*, 33(1), 35-53.
- [36] Husin, H. N., Nawawi, a. H., Ismail, F., & Khalil, N. (2011). Development of Hierarchy for Safety Elements and Its Attributes for Malaysia's Low Cost Housing. *Procedia Engineering*, 20, 71–79.
- [37] Al-dossary, S. A. (2008). *A Study of the Factors Affecting Student Retention at King Saud University, Saudi Arabia*. University of Sterling: Ph.D. Thesis.
- [38] Yusof, N., Abdullah, S., Zubedy, S., & Najib, N. 'Ulyani M. (2012). Residents' Maintenance Priorities Preference: The Case of Public Housing in Malaysia. *Procedia - Social and Behavioral Sciences*, 62(2003), 508–513.
- [40] Sheely, M. C., & Whalen, D. F. (2003). Contributors to Residence Hall Student Retention : Why do Students Choose to Leave or Stay ?
- [41] Nijenstein, S., Haans, A., Kemperman, A. D. a. M., & Borgers, A. W. J. (2014). Beyond demographics: human value orientation as a predictor of heterogeneity in student housing preferences. *Journal of Housing and the Built Environment*.
- [42] Muslim, M. H., Karim, H. A., & Abdullah, I. C. (2012). Satisfaction of Students' Living Environment between On-Campus and Off-Campus Settings: A Conceptual Overview. *Procedia - Social and Behavioral Sciences*, 68, 601–614.
- [43] Sawyerr, P. T. (2013). Student satisfaction with hostel facilities in Nigerian polytechnics. *Journal of Facilities Management*, 11(4), 306–322.
- [44] Liu, A. M. (1999). Residential satisfaction in housing estates: a Hong Kong perspective. *Automation in Construction*, 8(4), 511–524.

- [45] Ge, J., & Hokao, K. (2006). Research on residential lifestyles in Japanese cities from the viewpoints of residential preference, residential choice and residential satisfaction. *Landscape and Urban Planning*, 78(3), 165–178.
- [46] Ibem, E. O., Opoko, A. P., Adeboye, A. B., & Amole, D. (2013). Performance evaluation of residential buildings in public housing estates in Ogun State, Nigeria: Users' satisfaction perspective. *Frontiers of Architectural Research*, 2(2), 178–190.
- [47] Gouthier, M. (2012). Service excellence models: a critical discussion and comparison. *Managing Service Quality*, 22(5), 447–464.
- [48] Jones, C. R. (2004). A “scorecard” for service excellence. *Measuring Business Excellence*, 8(4), 45–54.
- [49] Solnet, D., & Kandampully, J. (2008). How some service firms have become part of “service excellence” folklore: An exploratory study. *Managing Service Quality*, 18(2), 179–193.
- [50] Khan, H., & Matlay, H. (2009). Implementing service excellence in higher education. *Education + Training*, 51(8/9), 769–780.
- [51] Creswell, J.W (2012). *Educational Research: Planning, Conducting and Evaluating Quantitative and Qualitative Research* (4<sup>th</sup> Ed). Boston: Pearson.

#### AUTHORS

**First Author** – Musa Alkali Abubakar, Masters Student, University Tun Hussein Onn Malaysia. modibbo23@yahoo.com.

**Second Author** – Rozilah Kasim, Assoc. Professor, University Tun Hussein Onn Malaysia. Rozilah@uthm.edu.my

**Third Author** – Matthew Mamman, Assistant Lecturer, Kaduna Polytechnic, Nigeria. Mamman16ali@yahoo.com

**Correspondence Author** – Musa Alkali Abubakar, Masters Student, University Tun Hussein Onn Malaysia.

[modibbo23@yahoo.com](mailto:modibbo23@yahoo.com), [abufatima34@gmail.com](mailto:abufatima34@gmail.com). +60166884429

# The effects of business ethics on consumers' perceptions of merchandizing and service giving businesses in Mekelle, Ethiopia

Gebeyehu Jalu Negassa

Marketing Management, Mekelle University Lecturer

**Abstract-** Economic activities of people are causing major threats to environment and to survival of all life on the earth. Importance of ethics in the business world is superlative and global in its nature. The fact is that some businesses operate in unethical and socially irresponsible way. The unethical action of businesses in developing countries is highly linked with economic problem. Some customers are not enjoying quality goods and services at their cost. Though there is such serious problem, yet I could not find study conducted in the area to describe the situation or to identify root causes of the problem that enable decision makers to take appropriate action. So, the study going to evaluate business ethical practice of the town along with causes and effects of unethical business practice in the town. Both quantitative and qualitative has been used in order to secure reliable data from all possible sources in a confidential manner. Primary data has been collected by using questionnaire, interview and focus group discussion to collect the desired data from customers and businesses (both merchandizing and service providing businesses). The study has been conducted through a case study. As the target population of the study has been consumers and business organizations of Mekelle town. The sample for the study has been selected from customers and merchandizing and service rendering business organizations. A Sample size of 150 is taken, the collected data has been analyzed using both qualitative and quantitative methods and the data analysis has been supported by SPSS 16.0 software. As result shows Several business misconducts and corporate talks have resulted to a new kind of consumer who is more skeptical and critical than ever, affecting individual choices, perceptions and system of values.

**Index Terms-** Social responsibility, corporate social responsibility, consumerism, product liability and abnormal profit.

## I. BACKGROUND OF THE STUDY

Economic activities of people are causing major threats to environment and to survival of all life on the earth. Business ethics is current issue of the world. Importance of ethics in the business world is superlative and global in its nature. The fact is that some businesses operate in unethical and socially irresponsible way where as some businesses recognized their ethical duty and act accordingly. The dimension of ethical issues include consumerism, employee treatment, community wellbeing, protection of the environment, obeying government

regulations, fair competition and compliance with laws and industry standards. Current ethical duties of business organization not only concern for the present population on Earth but also for future generations. These are new ethical duties that have arisen as man has begun to have a serious effect on the Earth's ecological systems in general and on other people in particular (Baker, 2007).

In developed countries of the world business firms are stressed with a novel role, which is to congregate the desires of the present generation without negotiating the ability of the next generations to meet their own needs. Organizations are being called ahead to take responsibility for the ways their operations force societies and the natural environment. They are also being asked to pertaining sustainability principles to the ways in which they conduct their business (D'Amato et al, 2009).

In developing countries of the world there are a number of business firms that conduct their activities in unethical manner. This unethical action of businesses in developing countries is highly linked with economic problem. Particularly many peoples in developing countries like Africa are striving to satisfy their basic needs. Combined with other causes, unethical practices to satisfy their economic interest created serious problem on business operations of developing countries of the world. Still there are some business firms do their tasks in ethical and social responsible way (Baker, 2007).

Business people contribute to a social and ethical responsibility to pleasure their consumers reasonably and operate in a manner that is not harmful to them. This action is said to be Consumerism. It is based on the conviction that consumers have certain rights. A frequently quoted statement of consumer rights was made by President Kennedy (1962). These rights of customers are summarized as following:

**The Right to Be Safe** modern business people must be familiar with obligations, both moral and legal, to guarantee the safe operation or products/services they providing customer should not cause harm on their health. A company should assume product liability for health problem caused by its product or service. Items that go ahead to injuries, either directly or indirectly can have devastating consequences for their makers. Many companies put their products through precise testing to avoid safety problems. Companies have to try to consider all possibilities and provide adequate warning of potential dangers. Sometimes substandard, defective or expired products cause illness or even death among consumers.

**The Right to Be Informed** Consumers should have access to product information to make responsible buying decisions.

False or misleading promotion of company's product/service is a violation of business ethics and regulations that govern advertising truthfulness. These rules prohibit businesses from making unproven claims about the performance or superiority of their goods or services. The responsibility of business to preserve consumers' right to be informed extends beyond avoiding misleading promotion. All communications with customers from salespeople's comments to warranties and invoices must be controlled to clearly and accurately inform customers. To protect their customers and avoid claims of insufficient information, businesses often include warnings on labeling of their products.

**The Right to Choose** Consumers ought to have the right to choose which goods and services they need and want to purchase. Socially accountable firms endeavor to preserve this right, even if they reduce their own sales and profits in the process. Some business firms force buyers to buy goods or use services without their preference.

**The Right to Be Heard** Consumers supposed to be able to articulate legitimate suggestions and complaints to suitable parties. Many companies use considerable endeavor to ensure full hearings for consumer complaints. Still there are a number of business firms that have no interest to listen customer complaints. Even they abuse customers by contradicting the concept which holds that 'customers are king' as they determine survival and profitability business organizations.

### 1.1. Statement of the Problem

According to Josie Fisher (2004, pp. 391-400) as cited by Bekele Gebisa (2010), business ethics is the code of moral principles that sets standards of good or bad, or right or wrong, in one's conduct and thereby guides the behavior of a person or group. Particular business ethical issues in this study were product safety, employee health and safety, social responsibility and obligation of the company to the environment. Product safety is an important issue that needs to be underlined in the relationship between business and consumers. Most consumers lack the expertise to assess the safety of today's technologically sophisticated products and must rely at least to some extent on the impression they are given by sellers. Therefore, the growing lack of confidence in the market system to protect consumer safety is demonstrated by the increase in consumer protection legislation (Hoffman and Frederick, 1995).

An organization that wants to earn sustainable profit over the long period of time is well advised to perform its business operation in ethical and social responsible way. Businesses also must take into account a wide range of social and environmental issues into consideration. In short, businesses must find the right match between doing what is ethical and doing what is profitable.

This means businesses expected to balance the qualitative dimensions of consumer, employee, and societal benefits, with the quantitative measures of sales and profits. In today's business practice social performance of companies can be seen from provision of quality product, reasonable price of a product/service, employment opportunity, providing equal employment opportunities, treatment of employees, environmental protection, providing a safe and healthy workplace. To make known their ethical practices and social responsibility, several companies highlight charitable

contributions and community service in their annual reports and on their Web sites (Business in global environment, 2009).

There is an amounting awareness that business needs to manage its relationship with the wider society. Businesses are responsible and accountable for their business impact on society and the natural environment beyond legal compliance. Meeting these challenges requires the combined efforts of a global society and responsible leadership devoted to diversity, ethics, and values (D'amato et al, 2009).

In order to speechless problems and issues caused by unethical practice and social irresponsibility of business organizations, it needs systematic and fact-finding research to identify the real problem. Resolving an ethical problem requires the analysis of particular circumstances and the study of specific facts. Unless it is solved with detail analysis and investigation, it is difficult to ensure business instability caused by unethical, unsafe and unfair business practices which is bad for consumers, the economy, the society and the government. It disturbs market condition, force society to use defective product, reduce government revenue and force ethical firms run out of the market (Baker, 2007).

In Mekelle many customers are suffering from unethical as well as illegal business practices of business firms. From my life experience in the town, I observed some businesses operate to deceive customers and they do not worry for social wellbeing. They are trying to make killing profit. Even though Mekelle is recognized as the center of trade activities, a number of unethical business practices and social irresponsibility of business organizations observed. Ethical practice of a number of business organizations were deviated from ethical principles and theories. Some customers are not enjoying quality goods and services at their cost. Though there is such serious problem, yet I could not find study conducted in the area to describe the situation or to identify root causes of the problem that enable decision makers to take appropriate action. So, the study going to evaluate business ethical practice of the town along with causes and effects of unethical business practice in the town.

### 1.2. Objectives of the Study

The general objective of the study is to evaluate business ethics practices of companies operating in Mekelle town. Particularly, the research going to achieve the following:

1. To examine whether brand equity is being affected in a positive way by manufacturing and service giving business.
2. To investigate consumer's evaluation of companies based on moral criteria, except of economic and financial ones.
3. To examine how the consumers keep on buying if the brand of their choice will not fulfill their expectations in moral terms.

## II. THEORETICAL FRAMEWORK

There are different approaches to define business ethics; among utilitarian, religious, and the self-interest approach are the prominent. The utilitarian states that morally correct course of action is one that brings the greatest good for the greatest number of people. The religious view, emphasized in Judeo-Christian tradition and the Muslim religion, is where a person should treat others in the same way he/she wants to be treated. The self-interest perspective is where an action is morally right if it

increases benefits for the individual in a way that does not intentionally hurt others. Today's understanding of ethics is a combination of these approaches. It is clear that the utilitarian approach is a step higher than the other two where it pushes the limits from profiting self without hurting anybody else, to profiting others with actions one pursues (Gormus,2004).

Ethics refers moral evaluations of decisions and actions as right or wrong on the basis of commonly accepted principles of behavior. Ethics usually concerns relations of mutual concern in society between all individuals and the need to limit one's self-interest when it goes against the general interest (Ferrell, 1991).

## 2.1. Theories of business ethics

### 2.1.1. The Stockholder Theory

According to this theory, managers act as agents for the stockholders. They are empowered to manage the money advanced by the stockholders, but are bound by their agency relationship to do so exclusively for the purposes delineated by their stockholder principals. They work to maintain the interest of stakeholders. The existence of this fiduciary relationship implies that managers cannot have an obligation to expend business resources in ways that have not been authorized by the stockholders regardless of any societal benefits that could be accrued. This implies that a business can have no social responsibilities. Their social responsibility is to increase their money by using resource properly. Stakeholder theory holds that effective management requires the balanced consideration of and attention to the legitimate interests of all stakeholders, defined as anyone who has "a stake in or claim on the firm." This has been interpreted in both a wide sense that includes "any group or individual who can affect or is affected by the corporation," and a more narrow sense that includes only "those groups who are vital to the survival and success of the corporation." It is perhaps more familiar in its narrow sense in which the stakeholder groups are limited to stockholders, customers, employees, suppliers, management, and the local community. Thus, as an empirical theory, the stakeholder theory asserts that a business's financial success can best be achieved by giving the interests of the business's stockholders, customers, employees, suppliers, management, and local community proper consideration.

### 2.1.2. The Social Contract theory

It asserts that all businesses are ethically obligated to enhance the welfare of society by satisfying consumer and employee interests without violating any of the general rules of justice. The social contract theory is explicitly modeled on the political-social contract theories of thinkers such as Thomas Hobbes, John Locke, and Jean-Jacques Rousseau. The social contract theory is based on an implicit agreement between society and business firms in which society recognizes the existence of the entity by using resources on the condition that it serves the interests of society in certain specified ways like ethical operation and social responsibility. This generalization may be thought of as giving rise to a social contract with two terms: the social welfare term and the justice term.

**I. The social welfare term** recognizes that the members of society will be willing to authorize the existence of businesses only if they gain by doing so. Further, there are two distinct

capacities in which the members of society stand to gain from businesses: as consumers and as employees. As consumers, people can benefit from the existence of businesses in at least three ways: Firstly businesses provide increased economic efficiency by maximizing the advantages of specialization, improving decision-making resources, and increasing the capacity to acquire expensive technology. Secondly businesses provide stable levels of output and channels of distribution. And thirdly they provide increased liability resources from which to compensate injured consumers (public goods). As employees, people can benefit from the existence of businesses by receiving increased income potential, diffused personal legal liability for harmful errors, and the ability to participate in "income-allocation schemes separated from the vicissitudes of their capacity to produce.

However, businesses can also have negative effects on consumers and employees. People's interests as consumers can be harmed when businesses pollute the environment and deplete natural resources, undermine the personal accountability of its constituent members, and misuse positional power. Therefore, when fully specified, the social welfare term of the social contract requires that businesses act so as to:

- Benefit consumers by increasing economic efficiency, stabilizing levels of output and channels of distribution, and increasing liability resources;
- Benefit employees by increasing their income potential, diffusing their personal liability, and facilitating their income allocation; while
- Minimizing pollution and depletion of natural resources, the destruction of personal accountability, the misuse of political power, as well as worker alienation, lack of control over working conditions, and dehumanization.

**II. The justice term** recognizes that the members of society will be willing to authorize the existence of businesses only if businesses agreed to remain within the bounds of the business ethics and social responsibility. Admittedly, precisely what these responsibilities require is far from what already settled. However, since there seems to be general agreement that the least they require is that businesses "avoid fraud and deception show respect for their workers as human beings, and avoid any practice that systematically worsens the situation of a given group in society, it is reasonable to read the justice term as requiring at least this much.

### 2.1.3. Importance of Business Ethics and Social Responsibility

Businesses have great potential to change living standard of the community and to combat poverty through utilization of economic resources in productive way if done ethically and considering the impact of their operation on the society and ecology. This can bring fast economic growth that increases living standard of the society. They produce goods and services that customers want and they create job opportunity. Through paying taxes, they contribute to government revenue that can finance schools, hospitals and other public services

### 2.1.4. Causes of Business Ethics



The motivation of being unethical is to generate a killing profit. In such case, the unethical individual or company profits while other individuals, companies, societies or future generations lose. In such an instance, short-term private interests are favored over long-term customer and public interest. The lack of ethics in business can crash stable and sustainable business system at country level or internationally. Unhealthy competition, dishonesty and violence can poison the environment in which healthy businesses can run. Business organization probably is less efficient and loses profitability in the long period of time if it is completely immoral and unethical. (BAKER, 2007) Poitras also mentioned intention to generate abnormal profit as major causes of unethical business practice. This makes the firm suffer from shifting of customer to buy competitors product/service and declining profits in the long-run. Short-term interest of a company for abnormal profit is given priority over the interest of business players, social wellbeing and ecological conditions. Lack of ethics (Unhealthy competition, dishonesty, fraud, abnormal profit etc) in business can disturb the healthy business system, leading to economic and social crises of particular country, city or company. Many businesses even not agree on the importance of ethical operation and social responsibility of businesses, whereas others agree on its importance but they refuse to incorporate in their business system and implement it (Poitras, 1994).

#### 2.1.5. Standards of Business Ethics

According to BUSA (2009), the following are recommendable standard of business ethics that should be implemented by business organizations:

**Responsibility:**-responsibility requires taking ownership of and being accountable for, one self's acts and omissions. It requires taking care of what is entrusted to somebody, recognizing the economic, social and natural environments in which the business operate. It include Exercising obligations with due care, diligence and the required skill and Pursuing business practices that are economically, socially, and environmentally sustainable

**Integrity:**-integrity requires doing what we say, and always acting in good faith. This builds trust, which is necessary operate profitable business. It covers being truthful and honest in all dealings with customer and honoring commitments and delivering what are promised.

**Respect:**-respect requires acknowledging others' rights and inherent human dignity. Treating customers with dignity,

recognizing their interests and capabilities and avoiding unjustified discrimination of customers are vital components of customer respect.

**Fairness:**-fairness requires even-handedly balancing the interests of various parties, ensuring that everyone gets what is right. Supporting free and fair competition by not being involved in price-fixing or other anticompetitive activities and negotiating in good faith, and refraining from coercion are advisable here.

#### 2.1.6. Ways of Shaping Ethical Conduct in Organizations

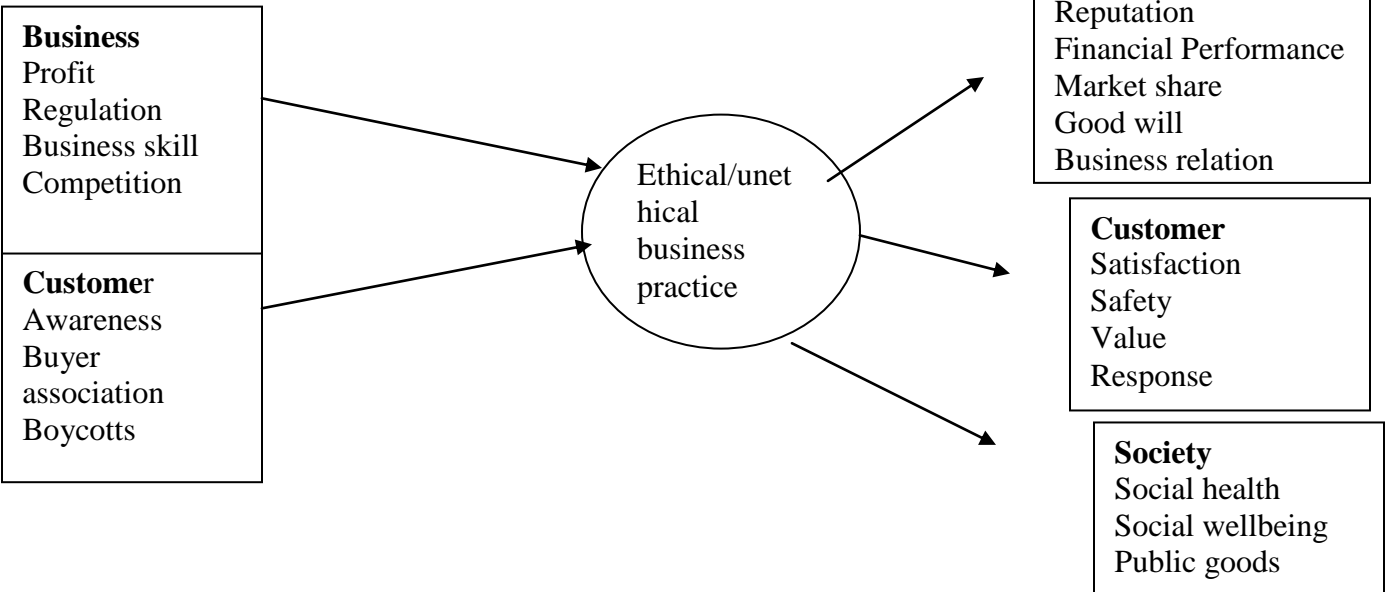
Most ethical practices in business reflect the values of the firm's corporate cultures. Development of a corporate culture to support business ethics based on four elements: ethical awareness, ethical reasoning, ethical action, and ethical leadership. If any of these four factors is missing, the ethical climate in an organization will weaken.

**Ethical Awareness:** - ethical dilemmas occur frequently in the workplace. So employees need help in identifying ethical problems when they serve customers & they need guidance about how the firm expects them to respond. One way for a firm to provide this support is to develop a code of conduct. Companies use their codes of conduct to specify ground rules and/or identify key corporate values and provide frameworks that guide employees when dealing with customers.

**Ethical Education:** -although a code of conduct can provide an overall framework, it cannot detail a solution for every ethical situation. Some ethical questions are confusing, so businesses must provide instituted ethics trainings and awareness creation programs.

**Ethical Action:** - firms must provide structures and approaches that allow decisions to be turned into ethical actions. A firm whose managers set unrealistic goals for employee performance may find an increase in cheating, lying, and misdeeds, as employees attempt to protect themselves.

**Ethical Leadership:**-Executives must not only talk about ethical behavior but also demonstrate it in their actions. This principle requires employees to be personally committed to the company's core values and be willing to base their actions on them. The damage from ethical misconduct can powerfully affect a firm's customers and its profit. In more clear way the conceptual frame work shows that the cause of business ethics and its effects.



III. METHODOLOGY

Both quantitative and qualitative data has been used in order to secure reliable data from all possible sources in a confidential manner. Primary data has been collected by using questionnaire, interview and focus group discussion. Both close ended and open ended questionnaire has been prepared in accordance with research objectives and research questions to collect the desired data from customers and businesses (both merchandizing and service providing businesses). The study was conducted through a case study. As the target population of the study has been consumers and business organizations of Mekelle town, it is not feasible and economical to use census study. Therefore case study method has been the appropriate to accomplish the desired objective of the study. The sample for the study has been selected from customers and merchandizing and service rendering business organizations. Based on similar studies conducted by Guo et al (2009) a Sample size of 150 is taken. This is done purposefully to collect the desired data required to accomplish the proposed study. The data analysis has been supported by software SPSS 16.0 to infer generalization about business ethics practices of the town based on the finding of the study.

IV. ANALYSIS AND INTERPRETATIONS

4.1. Demographic characteristics of respondents

This chapter focuses on the data analysis of the current research. First, the demographic characteristics of the respondents that participated in the survey are being presented. Then, there is the description of the data information and preparation, as well as the descriptive characteristics of the

sample and the scaling check. The first question of the case aimed to identify the demographic characteristics of the respondents. First, there was a question concerning their gender. According to their answers 60% of the sample was male while 40% of them female. The second question of the case was concerning the age of the respondents. As the results are shown, most of the individuals answering the questionnaire belong in the range of age: 18-24 (66% of the sample) while 29% of them are from 25 to 33 years old. Finally, there was a question concerning the education level of the respondents which is separated into four main categories. In the first category there were people who have finished the high school. In the second and third, are individuals who have obtained a Bachelor or a Master Degree respectively. In the fourth category there are those who own a Ph.D. Degree, while on the fifth there are those who work as Academics. As the result shows most of the participants own a diploma (52% of the respondents) while 34% of them have a Bachelor Degree.

2.2. Business Ethics Descriptive Statistics of the study

4.1.1. Business ethics

To begin with, the business ethics mean ranged from 5.47 to 6.17. On one hand, the highest mean rate belongs to the responsibility of a company towards its employees' rights. On the other hand, the lowest rate item is the responsibility of a company towards the social initiatives. In general, all of the mean rates are considered high, since they are more than 3.5 points in the Likert Scale, which indicates the general demand of the consumers for manufacturing and service giving business ethics. Refer table1.

Table 1: Business Ethics Descriptive Statistics

	N	Minimum	Maximum	Mean	St.devation
I perceive positively a company when it seems very	150	1	7	5.59	1.054

concerned with the local community.					
I perceive positively a company when it seems very concerned with the environment protection.	150	1	7	5.80	1.158
I perceive positively a company when it seems very concerned with the rights of their employees.	150	3	7	6.17	.948
I perceive positively a company when it seems very concerned with their employees in third world countries.	150	1	7	5.69	1.171
I perceive positively a company when is actively participating in social initiatives.	150	1	7	5.47	1.113

**2.3. Consumer Perceptions**

Additionally, the consumer perceptions items ranged in mean from 3.32 to 4.24. The item describing the consumers' experiences, concerning businesses' behavior based on what they

heard from others or the media in the past year, had the lowest rate, while their expectations concerning businesses behavior in the coming year, and had the highest rate. Refer table2.

**Table 2: Consumer Perceptions Descriptive Statistics**

	N	Minimum	Maximum	Mean	St.devation
Based on my own experiences as a consumer in the past year, businesses I dealt with generally behaved:	150	1	7	4.071	1.351
Based on what I heard from others or the media in the past year, businesses behaved:	150	1	7	3.32	1.411
Based on my own experiences as a consumer last year, I expect businesses in the coming year to behave:	150	3	7	4.24	1.584
Based on what I heard from others or the media last year, I expect businesses in the coming year to behave:	150	1	7	4.12	1.578

**2.4. Brand Equity**

Brand equity items ranged from a mean of 4.28 to 5.07. The item that describes the willingness of a consumer to choose a considered ethical company even with many available choices of

alternative brands had the lowest mean rate. In contrary, the lowest mean rate belongs to the willingness of a consumer to buy from a company that is acting ethically as a first choice. Refer table3.

**Table 3: Brand Equity Descriptive Statistics**

	N	Minimum	Maximum	Mean	St.devation
When a company is acting ethically its products and services are my first choice.	150	1	7	5.07	1.084
When a company is acting ethically I feel myself loyal to this brand.	150	1	7	4.84	1.350
When a company is acting ethically even with many choices I will not choose alternative brands.	150	3	7	4.28	1.455
When a company is considered ethical, I believe that the brand is associated with very good quality.	150	1	7	4.49	1.598
When a company is considered ethical, I believe that the likelihood of this brand will function well is very high.	150	1	7	4.68	1.313
When a brand is considered ethical, I believe that the likelihood that this brand is reliable is very high.	150	1	7	4.97	1.342
A high ethical company is usually associated with the leader of its sector.	150	1	7	4.72	1.374
A high ethical company is usually recognized among its competitors.	150	1	7	4.95	1.325

**2.5. Willingness to Buy**

The mean of the willingness to buy items ranged from 3.81 to 4.34. The item with the lowest mean rate is the willingness to

buy from a brand, such as Nike for example. The item with the highest mean rate is the likelihood to purchase a brand. Refer table 4.

**Table 4: Willingness to Buy Descriptive Statistics**

	N	Minimum	Maximum	Mean	St.deviation
My willingness to buy from the ethical brand is high.	150	1	7	3.81	1.790
The likelihood of purchasing from the ethical and legal brand is high.	150	1	7	4.34	1.714
The probability that I would consider to buy from the ethical brand is high.	150	3	7	4.28	1.455

### V. CONCLUSION

This chapter focused on drawing conclusion on the basis of the analysis of the data, the research methods employed and the final results of this study. First the demographic profiles of the research respondents are demonstrated and the corresponding descriptive statistics are presented.

Moreover, the results demonstrating that although brand equity is not positively related with consumers' perceptions, the latter is positively related with consumers' willingness to buy. The implications of this study, both theoretical and managerial, as well as conclusions from the findings are discussed in the chapter that follows.

Today, in our contemporary and highly competitive business world, ethics and ethical considerations are being increasingly important due to the influence of globalization, new technologies, consumerism and the different type of crisis that we experience (financial, ecological, political, system of values).

- Consumers appear to be becoming increasingly more hostile to marketing, as marketing professionals' disregard for the ethical effects of their actions.
- Several business misdeeds and corporate talks have resulted to a new kind of consumer who is more skeptical and critical than ever, affecting individual choices, perceptions and system of values.
- Socially-Responsible Marketing, includes morally-just marketing alongside socially-responsible and ecologically-friendly marketing but it is far from common practice in the marketing and businesses community (Manrai & Manrai, 2007), as empirical research results consistently fail to link its various forms, such as corporate citizenship, to measurable financial outcomes.
- Despite the fact that business ethics is considered as a multidimensional and complex phenomenon, it seems as an opportunity for companies to invest in it and gain insights, to invoke positive brand images and consumer perceptions.

### REFERENCES

[1] Afire,(2010). Protecting the consumer: Law, policy and the practice in Ethiopia December, 2010.  
 [2] Alessia D'Amato, Sybil Henderson & Sue Florence (2009). Center of corporate social  
 [3] BUSA (2009). South African Charter of Ethical Business Practice, August 2009 Retrieved April 29 from <http://www.businessethicsworld.com>.et Business ethics and normative theories on May 10, 2011 from <http://www.emeraldinsight.com/>

[4] Business ethics and social responsibility <http://www.epic-online.net> accessed on December9, 26, 2014  
 [5] Ethical issues in business environment retrieved on December 07, 2014 from [http://www.it.nuigalway.ie/staff/h\\_melvin/prof](http://www.it.nuigalway.ie/staff/h_melvin/prof)  
 [6] Ferrell, O.C. and Fraedrich, J. (1991). Business Ethics, Houghton Mifflin, Boston  
 [7] Friedman, Milton (1970). The Social Responsibility of Business is to Increase its Profits the New York Times Magazine September.  
 [8] Jingfu Guo, Likun Sun & Xueli Li (2009). Corporate Social Responsibility, Assessment of Chinese Corporations International journal of business <http://www.cesenet.Org/journal.html>  
 [9] John Hooker (2003). Why business ethics? Carnegie Mellon University April 2003  
 [10] John Kennedy (1962) the right of consumers, retrieved on May 01, 2011 from [www.globethics.net](http://www.globethics.net)  
 [11] Kibrom, Berhe (2008). Life in the streets of Adama, Addis Abeba July, 2010  
 [12] Manrai, L. A., & Manrai, A. K. (2007). Business-Society relationship: A new framework for Societal Marketing Concept. Paper presented at the International Association for Business and Society, Florence, Italy.  
 [13] Mesay Mulgeta (2010). Food security attainment role of urban agriculture a case study from Mekelle town, Northern Ethiopia, November 3, 2010  
 [14] Necmettin A. Gormus (2004). Economic Analysis of ethics and social responsibility in today business environment, December, 2004  
 [15] Patrios Kantin (1994). Business ethics and corporate social responsibility retrieved on April 26, 2011 from [www.thetimes100.co.uk/edu](http://www.thetimes100.co.uk/edu)  
 [16] Responsibility and sustainable business center of guide to leadership tasks and functions  
 [17] Sayali B. Patil (2010). Ethical issues in business, journal of business ethics retrieved on May 05, 2011 from [www.globethics.net/Ethics](http://www.globethics.net/Ethics)  
 [18] U.S. department of commerce (2004). U.S. Department of Commerce International Trade Administration Washington, D.C  
 [19] Wallace R. Baker (2007). A reflection on business ethics a Commissioned Paper for the UNESCO Forum, Paris April 2007

### AUTHORS

**First Author** – Gebeyehu Jalu Negassa, Department: Marketing Management, Mekelle University Lecturer

# A Study to Assess the Effectiveness of Structured Teaching Programme on Knowledge regarding Substance Abuse among Adolescents at Selected Nursing Colleges of Udaipur District, Rajasthan, India

Yogeshwar Puri Goswami<sup>1</sup>, Dr. Jayalakshmi L.S.<sup>2</sup>, Dr. D.M. Mathur<sup>3</sup>

<sup>1</sup>PhD.(N) Scholar, Geetanjali College of Nursing, Udaipur, Rajasthan, India,

<sup>2</sup>Dean, Geetanjali College of Nursing, Udaipur, Rajasthan, India,

<sup>3</sup>HoD & Professor Dept. of psychiatry Geetanjali Medical College & Hospital, Udaipur, Rajasthan, India

**Abstract-** Adolescence is a stage of struggle for identity. It is evidenced by rebelliousness, adventure seeking behavior and oppositional defense. The future citizens are at great risk for early initiation to drugs and other psycho active substances. Therefore, a quasi experimental study to assess the effectiveness of structured teaching programme was used to assess knowledge of adolescents regarding substance use. One group pre-test post-test design was used for this study. Convenient sampling technique is used on the sample for the present study consists of 91 adolescents age of 17- 18 yrs. from selected B.Sc. Nursing colleges at Udaipur district of Rajasthan. Self administered Knowledge questionnaires (Pre test – Post test) were administered. The collected data were analyzed by using descriptive & inferential statistics based on predefined objectives of the study. Present study shows that pre test knowledge level of students was significantly ( $P < 0.05$ ) less towards substance abuse. Study reveals that proper education (STP) enhance post test knowledge among students regarding substance abuse.

**Index Terms-** Substance abuse, Adolescents, Knowledge, Structured teaching programme.

## I. INTRODUCTION

Today's children are tomorrow's citizen it is necessary for us to prevent adolescents to become prone towards substance abuse. An adolescent is a period when lots of changes take place in body & mind. Adolescents start using harmful and illegal substances at younger age. Drinking, smoking, and drug use by adolescents affect general health, physical growth, emotional development and school performance. Continues use of such substance lead physical & psychological harm, and is difficult to stop **Barking SL, smith KS, Durant RH 2002**<sup>1</sup>

This may lead changes in a teen's alertness, perceptions, movement, judgment, and attention, making the teen more likely to engage in high-risk behaviors. Alcohol and drug use among adolescents is a leading cause of death and disability from automobile accidents, suicide & violence. **Vijayalakshmi IB 2004**<sup>2</sup>

Tobacco continues to be the substance causing the maximum health damage globally, According to WHO estimation these are around 1.1 thousand million smokers in the world, about 1/3 of

global population aged 15 and above. Tobacco products are available in smokable forms such as cigarettes, cigars, and pipers, and smokeless form of chewing tobacco and snuff.<sup>3</sup>

It has been reported that the substance use in 2002 and 2003, 51 percent of high school seniors and 59 percent of young adults admitted to having used an illicit substance including about 45 percent of each who had used cannabinal example Marijuana, and almost 15 percent have taken amphetamines. 2.5 percent of world population confirms cannabis use compared with cocaine 0.2 percent consuming cocaine and 0.2 percent consuming opiates. **Francis JL, Mullen K 2006**<sup>4</sup>

According to UN report, One million heroin addicts are registered in India, & un-officially there is as many as five million. Cannabis, heroin & Indian produced pharmaceutical drugs are the most frequently abuse drugs in India. The International Narcotic Control Board reported that in India person addicted to opiates are shifting their drug of choice from opium to heroin **Srivastava , A pal, HR Dwivedi et al 2003**.<sup>5</sup>

Various studies in India shows that 80% of adults start using psychoactive substance before 18 years of age & if they continue with it addiction may be develop within three years with increase risk of physical & mental illness **Singhi S, Broca JS, Mathur GM 2007**.<sup>6</sup>

This may lead changes in a teen's alertness, perceptions, movement, judgment, and attention, making the teen more likely to engage in high-risk behaviors. The investigator observed that the adolescents are at high risk for substance abuse and with the experience of working in De-addiction center made researcher to conduct a study on "SUBSTANCE ABUSE". Adolescents are the future citizen of our country, thus interest aroused in the researcher to assess the effectiveness of structured teaching programme regarding substance abuse among adolescents".

## II. RESEARCH ELABORATIONS

### Statement of the problem -

"A Study to Assess the Effectiveness of Structured Teaching Programme on Knowledge regarding Substance Abuse among Adolescents at Selected Nursing Colleges of Udaipur District, Rajasthan, India"

### III. OBJECTIVES

1. To assess the level of knowledge regarding substance abuse among adolescents in selected nursing colleges.
2. To evaluate the effectiveness of structured teaching programme on substance abuse among adolescents in selected nursing colleges.
3. To find association between post test knowledge scores of adolescents' substance abuse with selected demographic variables.

### IV. HYPOTHESIS:

$H_{01}$  :- There will be statistically no significant relationship between the score obtained on the level of knowledge regarding substance abuse in adolescents after structured teaching programme.

$H_{02}$ - There will be statistically no significant relationship between selected socio demographic variables & score obtained on level of knowledge regarding substance abuse among Adolescents.

### V. MATERIALS & METHODS

**Research approach & design:** quasi experimental one group pre- test, post- test design, to measure The Effectiveness of Structured Teaching Programme.

**O1** → **X** → **O2**  
**Pre-test**      **Intervention**      **Post-test**

### Figure 1: Schematic representation of one group pre-test post-test research design.

**Sample and sampling technique:** Convenient sampling technique is used on the sample for the present study consists of 91 adolescents age of 17- 18 yrs. from selected B.Sc. Nursing colleges at Udaipur district of Rajasthan.

**Tool:** The self structured questionnaire was prepared which consists of three parts.

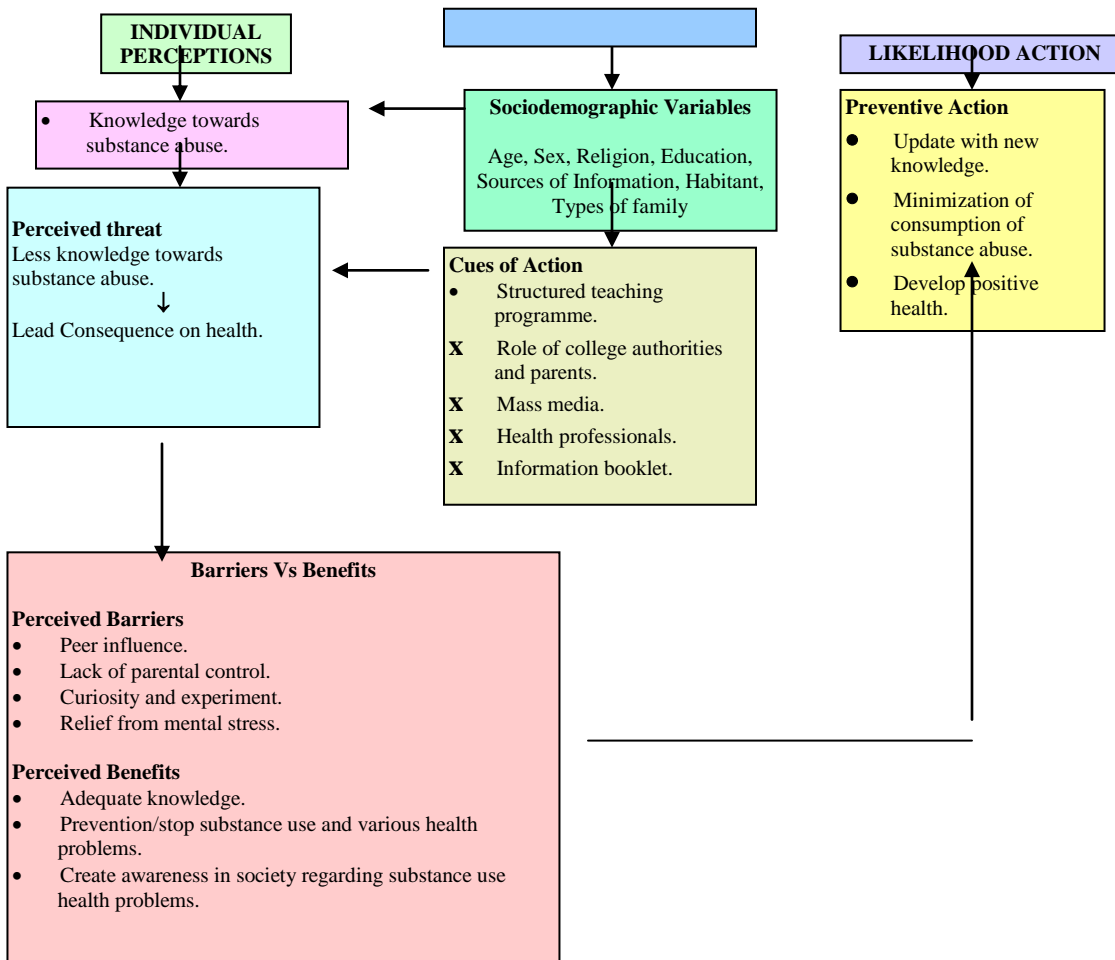
**Part I:** Demographic Proforma: Consists of 07 items of socio demographic data which includes information of respondents about Age, Gender, Religion, Education, Source of Information, Habitant and Types of family of adolescents.

**Part II:** Knowledge questionnaire : Consists of 30 items of objectives type related to knowledge of adolescents regarding substance abuse, Causes and Risk factors, Signs and symptoms, Complications and Treatment / prevention for substance abuse. All the items were scored as the each correct answer was given a score of '1' and wrong answers a score of '0'.

### Conceptual Framework –

Maiman and Becker's Health Belief Model is used for framing the concept of the present study on the effectiveness of structured teaching programme regarding substance abuse among adolescents. This conceptual frame work provides a way that how people will react in relation to health care. This model proposes that people will not attempt to adopt the preventive practices unless the disease is not threatening to some aspect of their lives.





- Under Study X Not Under Study

**Figure 2: Conceptual Framework of the study  
Maiman and Becker's Health Belief Model (1978)**

**Data collection method & Ethical consideration:** The data collection procedure was carried out from 16<sup>th</sup> Aug.2013 to 30<sup>th</sup> Aug. 2013. Formal written permission obtained from college Dean / principal from Geetanjali College of Nursing & Udaipur College of Nursing. The investigator took consent from the adolescents. Confidentiality was maintained during data collection. The average time taken was 30 to 35 minutes.

After an interval of seven days, the post test was administered by using the same knowledge questionnaire to evaluate the effectiveness of Structured Teaching Programme respectively.

**Data analysis:** The obtained data will be analyzed in terms of the objectives and hypothesis of the study by both descriptive and inferential statistics.

The mean post test scores (26.90%) was higher than the mean pre test scores (12.93%) with 't' value (t=18.9425) being significant at p 0.001% level on the finding of the data indicates that this study was feasible & enhance the knowledge of adolescents regarding substance abuse.

## VI. RESULT

### Section I: Description of demographic Proforma

Age of all participants 91 was 17-18 years, 65% participants were male and 35% were female, Majority of them 57% were Hindus, Most of them 58% participants were living in urban area and 42% participants were living in rural area. Students participated in this study were I yr. BSc.(N), Most of the participants that is 67% belonged to nuclear family and 33% belonged to joint family, Majority of them 44% participants had personal source of information, 34% got their information from electronic media & 22% participant had print media as their source of information.

### Section II: Distribution of student's knowledge regarding substance abuse.

**Table – 1 Assessment of level of knowledge of adolescents on substance abuse in pre & post test:  
N= 91**

Level of knowledge	Pre test		Post test	
	Frequency	%	Frequency	%
Adequate knowledge (>75 %)	-	-	76	83.35
Average knowledge (50 -75 %)	24	26.37	15	16.48
Inadequate knowledge (< 50 %)	67	73.62	-	-

knowledge score revealed that majority of them had [83.35%] adequate knowledge regarding substance abuse.

In relation to the knowledge of the pre –test none of the subjects had adequate knowledge, where as in post test

**Section III: Distribution to evaluate the effectiveness of structured teaching programme on adolescent’s substance abuse.  
N= 91**

DOMAIN	Pre test		Post test		Improvement Mean	t – test
	Mean	SD	Mean	SD		
Knowledge	12.93	3.57	26.90	5.15	13.97	t = 18.9425

P> 0.0001 (extremely statistically significant)

The obtained post test mean value 26.90 is higher than the pre test 12.93. The improvement between pre-test and post-test was 13.97 and obtained paired‘t’ test value was 18.9425, it is highly significant at 1% level p>0.001. Hence it is inferred that there is significant increase in the knowledge level of the adolescents regarding substance abuse after the structured teaching programme.

**Section IV: Determine the association between pre-test knowledge scores of adolescent’s substance abuse and their selected socio demographic variables**

There was the significant association between post test knowledge scores and selected variables like age, religion, year of education (P >0.01), sex & types of family (P >0.05 level), but there was no significant association between post test knowledge score and source of information & area of residence.

**VII. CONCLUSION**

The investigator observed that the adolescents are at high risk for substance abuse and with the experience of working in De-addiction center made researcher to conduct a study on “SUBSTANCE ABUSE”. Adolescents are the future citizen of our country, thus interest aroused in the researcher to assess the effectiveness of structured teaching programme regarding substance abuse among adolescents”.

**REFERENCES**

- [1] Barking SL, smith KS, Durant RH Adolescent’s attitude and social skills affect current substance use. Journal adolescent health 2002. 30 (6) P448-51.
- [2] Vijayalakshmi IB. Economic impact of smoking and cardio vascular disease. Tobacco and Poverty–A Vicious Circle. 2004 May: 18.
- [3] The ICD-10 Classification of Mental and Behavioural Disorders, Geneva. WHO Publicaion, 2002.
- [4] Francis JL, Mullen K, religiosity an attitudes towards drug Use addiction 2006. 88 (5) : 665-672
- [5] Srivastava , A pal, HR Dwivedi et al. (2003). National house hold survey of drug abuse in India. Report submitted to the Indian ministry of social Justice & empowerment & the united nation office for Drug & crime.
- [6] Singhi S, Broca JS, Mathur GM. Smoking behaviour of rural school boys. Indian Pediatrics. 2007; 24: 655-59.
- [7] Jose S. A study to assess the undergraduate students knowledge and attitude towards drug abuse in selected college of Kerala, university of Delhi 1994.

**AUTHORS**

**First author:** Yogeshwar Puri Goswami' PhD(N) Scholar, Geetanjali College of Nursing, Udaipur, Rajasthan, India,  
**Second author:** Dr. JayalakshmiL.S, Dean, Geetanjali College of Nursing, Udaipur, Rajasthan, India,  
**Third author:** Dr. D.M. Mathur, HoD & Professor Dept. of psychiatry Geetanjali Medical College & Hospital, Udaipur, Rajasthan, India

# Evaluation of Water Quality Pollution Indices for Heavy Metal Contamination Monitoring in the Water of Harike Wetland (Ramsar Site), India

Onkar Singh Braich, Sulochana Jangu

\* Department of Zoology and Environmental Sciences, Punjabi University, Patiala-147002, India

**Abstract-** The diverse functions of wetlands are being adversely affected by human activities. Harike wetland has high ecological significance as it provides home to diverse flora and fauna, habitat for feeding and breeding and social interactions. This paper discusses an integrated approach of pollution indices and statistical techniques to assess the intensity of heavy metal pollution discharged from various industries in Harike wetland. This wetland is highly polluted due to the rapid industrialization, urbanization and dumping of solid wastes. The water quality of the wetland has been studied with reference to various toxic metals. The metals analyzed include lead, chromium, iron, copper, nickel, zinc and cadmium. The quality of water has drastically deteriorated due to the mixing of the heavy metals. Most of the metal ions were in higher concentration compared to the international standards. It has been observed that the quality of water is not safe for various aquatic and even unfit for human drinking and irrigation purposes, therefore, necessary conservation and management measures should be taken to improve the deteriorating water quality of this globally recognized wetland.

**Index Terms-** Harike wetland; Ramsar site; Heavy metals; Pollution; Water quality

## I. INTRODUCTION

From the very dawn of human civilization, due to uncontrolled greed, the over utilization of natural resources has been taken place which caused unparallel devastation. Recently, with the unplanned growth of industrialization, rapid urbanization and degradation of aquatic resources, by using them as dumping grounds for sewage, deforestation, depletion of water resources has played a crucial role in deterioration of aquatic ecosystems on the earth. Wetlands are more affected these days because they receive polluted water from various sources through rivers and streams. Wetlands support unique aquatic biodiversity which is facing a serious threat. Some of the important organisms came under threatened categories of IUCN. Heavy metals, including both essential and non-essential elements, have a particular significance in eco-toxicology. They are highly persistent and have the potential to be toxic to the living organisms. Heavy metal concentrations in aquatic ecosystems are usually monitored by measuring their concentration in water (Ebrahimpour and Mushrifah, 2008). Human activities have led to accumulation of toxic metals in the natural environment (Karbassi and Bayati, 2005) and the extensive exploitation of natural resources has led

to increased pressure on aquatic ecosystems. Resultantly, due to an increased load of heavy metals the aquatic ecosystems have severely disrupted. Elevated concentrations of pollutants in these systems have resulted in bioaccumulation of toxic metals and a serious environmental problem, which threatens aquatic organisms and human health (Sasmaz et al., 2008).

Many large industrial factories including cement factories, paint manufacturing plants, dyeing industries, pesticide and insecticide factories, leather industries and tanneries are located along the banks of the river Sutlej and discharges polluted water into it and this water ultimately reaches at Harike wetland. Effluents from these factories have caused severe contamination of water in this wetland. The purpose of this study was to determine the concentrations of lead (Pb), chromium (Cr), copper (Cu), nickel (Ni), zinc (Zn), cadmium (Cd), aluminum (Al) and iron (Fe) in water of Harike wetland. The data collected will be shared with the Stake holder agencies to start immediate pollution mitigation and conservation measures.

## II. MATERIALS AND METHODS

### Study Area

The study area is situated in three districts of Punjab state i.e. Kapurthala, Tran Taran and Ferozepur with 4100ha area (Figure.1). This wetland included into the list of Ramsar sites in 1990. Harike wetland located at latitude of 31.17° N and longitude of 75.20° E. This wetland is also important because situated on the confluence of two rivers of the Indus river system i.e. Beas and Sutlej. The journey of the river Beas ends here and the river Sutlej flows downstream and enters into Pakistan. This is a riverine wetland, but due to large area it supports different type of habitats like palustrine, lacustrine and swamps. Due to its diverse nature, it supports vast variety of valuable flora and fauna. Unfortunately, this important aquatic ecosystem receives large quantity of untreated industrial effluents from adjoining cities through the inflow Rivers which are posing a serious threat to its existence.

### Water Sampling

Water samples were collected from March, 2013 to February, 2014 in four different seasons of the year from five sites in Harike wetland. The surface water samples were thoroughly filtered through cellulose nitrate filter paper to eliminate suspended solids and stored in plastic bottles with one liter capacity. 1 ml of concentrated nitric acid was added to it for

preservation. Heavy metal analysis has been done using Atomic Absorption Spectrophotometer (AAS).



Figure 1. Map of Harike wetland.

### Pollution evaluation indices

Generally, pollution indices are applied to estimate the pollution of the water samples under consideration. The indices used in this study, are heavy metal pollution index (HPI), heavy metal evaluation index (HEI) and degree of contamination ( $C_d$ ). These indices are used to evaluate quality water for drinking as well as irrigation purposes. The HPI and HEI methods provide an overall quality of the water with regard to heavy metals.

#### Heavy metal pollution index (HPI)

HPI index was developed by assigning a rating or weightage ( $W_i$ ) for each chosen parameter. The rating system is an arbitrarily value between 0 to 1 and its selection depends upon the importance of individual quality considerations or it can be defined as inversely proportional to the standard permissible value (Reddy, 1995; Mohan et al. 1996). In computing the HPI for the present water quality data, the concentration limits i.e. the standard permissible value ( $S_i$ ) and highest desirable value ( $I_i$ ) for each parameter were taken from the WHO standards.

The HPI is determined by using the expression below (Mohan et al. 1996):

$$HPI = \frac{\sum_{i=1}^n W_i Q_i}{\sum_{i=1}^n W_i}$$

Where  $Q_i$  is the sub-index of the  $i$ th parameter.  $W_i$  is the unit weightage of the  $i$ th parameter and  $n$  is the number of parameters considered. The sub-index ( $Q_i$ ) is calculated by

$$Q_i = \sum_{i=1}^n \frac{(M_i - I_i)}{(S_i - I_i)} \times 100$$

Where  $M_i$ ,  $I_i$  and  $S_i$  are the monitored value of heavy metal, ideal and standard values of the  $i$ th parameter, respectively. The sign (-) indicates numerical differences of the two values, ignoring the algebraic sign.

#### Heavy metal evaluation index (HEI)

The HEI method gives an overall quality of the water with respect to heavy metals (Edet and Offiong, 2002) and is computed as:

$$HEI = \sum_{i=1}^n \frac{H_c}{H_{mac}}$$

Where  $H_c$  is the monitored value of the  $i$ th parameter and  $H_{mac}$  the maximum admissible concentration of the  $i$ th parameter.

#### Degree of contamination ( $C_d$ )

The contamination index ( $C_d$ ) summarises the combined effects of several quality parameters considered harmful to domestic water (Backman et al. 1997) and the contamination index is calculated from equation below:

$$C_d = \sum_{i=1}^n C_{fi}$$

Where

$$C_{fi} = \frac{C_{Ai}}{C_{Ni}} - 1$$

Where  $C_{fi}$ ,  $C_{Ai}$  and  $C_{Ni}$  represent contamination factor, analytical value and upper permissible concentration of the  $i$ th component, respectively ( $N$  denotes the 'normative value').

#### Statistical analysis

To identify the relationship between various heavy metals in the water samples statistical analysis has been done by using Pearson's correlation matrix with the help of SPSS software.

### III. RESULTS

Heavy metal pollution is a serious and widespread environmental problem due to persistent toxicity, non biodegradable and bio-accumulation properties of these contaminants. The mean values of heavy metals detected in water from Harike wetland are presented in Table 1 and are compared to the WHO maximum permissible limits. Most of the heavy metals are above permissible limits prescribed under WHO standards.

#### Heavy Metals in Water

##### Lead

The level of Pb is 0.53 ppm which is above permissible limits in water comes from various industries like paint industry, refining and manufacturing of Pb coating goods. It is very toxic in nature and causes many diseases. A remedy must be sought for the gradual phasing out of Pb from various industries by using new technologies.

##### Copper

The Cu content in water is 0.26 ppm considered above permissible limit. The source of copper is mining, metal production, storage batteries and fertilizer production industries. Aquatic organisms are potentially at risk from Cu exposures, mitigation measures are required to reduce Cu inflow into the wetland.

##### Cadmium

The average Cd content in water is 0.01 ppm. Cadmium is non-essential element. The source of Cd in water is electroplating, alkaline batteries, mining and plastic industries. It interferes with metabolic processes in plants and can bioaccumulate in aquatic organisms and enters in food chain (Adriano, 2001). The concentration obtained during present course of work is above permissible limits.

##### Chromium

The average concentration of Cr in water is reported to be 0.12 ppm. This is possibly due to release of Cr in the effluent during various industrial operations. The effluents with high Cr content should be treated before discharge.

##### Nickel

The concentration of Ni is reported as 0.01 ppm. Nickel can be toxic to aquatic organisms such as reduction in skeletal calcification and diffusion capacity of gills (Moore, 1991). The

source industries are electroplating, steel industries, ceramics, storage batteries, dyeing and colouring of glass.

#### **Zinc**

The average concentration of Zn in water is 0.69 ppm which is below permissible limit. Zinc is used in plastic industries, cosmetics, steel processing, printing ink and in rubber production.

#### **Manganese**

The average abundance of manganese is 0.02 ppm which is below permissible limit. It is used in metallurgical processes, manufacturing of dry cell batteries and fertilizers.

#### **Cobalt**

The concentration of cobalt is 0.007 ppm which is within the acceptable range. Cobalt is present in industrial effluent coming from chemical industries, electrical and electronics and auto part manufacturing.

#### **Correlation matrix analysis**

In the present study, the correlation coefficient among various heavy metals has been calculated. The statistical analysis (Table 2) showed both positive and negative correlation among different metals. It is clear from the results that copper was positive correlated with most of the other metals whereas lead (Pb) is negatively correlated with other metals. Cadmium and Chromium is highly correlated with each other.

#### **Pollution indices**

The heavy metal pollution index of all the heavy metal have been calculated individually using the standards Table 3 and is represented by HPI, with range 115.4-7000 and mean concentration value 1304.65 of all metals, including all the seasons. The components considered include Cd, Cr, Cu, Fe, Mn, Ni, Pb and Zn. The results of pollution evaluation indices are presented in Table 4. The result of indices showed that the HPI for all the metals were above the critical limit of 100 proposed for drinking water by Prasad and Bose, 2001.

The degree of contamination ( $C_d$ ) was used as reference to estimate the extent of metal pollution (Al-Ami et al. 1987).  $C_d$  may be grouped into three categories as follows: low ( $C_d < 1$ ), medium ( $C_d = 1-3$ ) and high ( $C_d > 3$ ). The range and mean values of  $C_d$  were 0.4-352.33 and 44.85. The value of contamination index exceed 3, suggesting that water is highly polluted.

The heavy metal evaluation index used for a better understanding of pollution indices. The mean value of HEI was 45.85. By following the approach of Edet and Offiong (2002), the proposed HEI criteria for the samples are as follows: low (HEI  $< 10$ ), medium (HEI = 10-20) and high (HEI  $> 20$ ). The present level of HEI shows that the water quality falls within high zone of pollution.

#### **IV. DISCUSSION**

Metals are reported to be well concentrated in the water (Simpson, 1982; Everall et al., 1989). Bioaccumulation of these metals in many fish species and their organs have been reported world widely by Kumada et al., 1980; Wasternhagen et al., 1980; Osborne et al., 1981; Norris and Lake, 1984 and Evans, 1987. These metals in trace amount may play important role in the biochemical life process of the aquatic organisms (Tay et al., 2009). However, their high concentration becomes lethal to fish and other aquatic organisms when the duration of exposure to

these metals is prolonged (Deekay et al., 2010). Harike wetland also receives heavy metals pollution from various sources which persists through out the year. As, observed during present investigation the level of some highly toxic metals is above permissible limits. The high concentration is posing a big threat to valuable flora and fauna existing there.

Elmaci et al., 2007 reported that in water samples of Lake Uluabat Zn and Cu concentrations were significantly higher due to the industrial and domestic discharge. The same observations are found in inland waters of Hong Kong (Zhou et al., 1998). Panday et al., 2010 observed that in Ganga river, more than 80% of the water samples Cd and Ni levels above the recommended maximum permissible concentration, the kind of results was reported in Ona river by Adefemi and Awokumi, 2010. Similar observations are found in present study, concentration of Cd and Ni is above the maximum permissible concentration recommended by WHO.

Khan et al., 2005 states that some elevated concentration of heavy metals (Pb, Cr, Hg, Cd, Fe, Cu, Ni, Zn) were recorded in the surface water bodies near NLC corporation due to the untreated wastewater discharge, fly ash ponds and industrial effluents from the Neyveli mines industrial complex. Davis et al., 2006 and Abdulah, 2007 stated that high concentration of heavy metals present in the sediments than the water, because sediments accumulate more heavy metals. Glenn et al., 2009 observed the presence of heavy metals in the coastal lagoon of manila bay are due to the direct deposition of these metals from air pollution.

Thus, the present study is an attempt to detect the heavy metal concentration in the water of Harike wetland. If this trend is allowed to continue unabated, it is most likely that the food web complexes in this wetland might be at the highest risk of induced heavy metal contamination. This alarming concentration may also escort discomfort to the people living in the vicinity of this wetland. Hence, strict management actions should be taken into consideration in order to protect the ecological sustainability of this wetland.

#### **V. CONCLUSION**

The study shows that the water of Harike wetland exhibits high concentration of heavy metals like Cd, Cu, Pb, Cr, Ni, Co and Fe. The contamination index  $C_d$  ( $> 3$ ) place water quality in high contamination level and heavy metal pollution index HPI on the other hand consider the level of contamination critical. Fluctuations in concentration of various heavy metals have been observed in different seasons. The correlation coefficient indicates positive and negative correlation of these metals with each other. The revelations during the present study are startling and summons immediate attention from the stake holder agencies for its conservation management and sustainable development so that optimum utilization of this wetland may be carried out.

#### **ACKNOWLEDGMENT**

We express our special thanks to the Head, Department of Zoology and Environmental Sciences, Punjabi University Patiala for providing necessary laboratory facilities funding by UGC-BSR scheme to carry out this work.



REFERENCES

1. Abdullah, H., Jovita, S., Ahmed, Z.A. (2007): Heavy metals (Cd, Cu, Cr, Pb and Zn) in meretix roding, water and sediments from estuaries in Sabah, North Borneo. – International Journal of Environmental and Science Education 2: 69-74.
2. Adefemi, S.O., Awokunmi. E.E. (2010): Determination of physico-chemical parameters and heavy metals in water samples from Itaogbolu area of Ondo-State Nigeria. - Africian Journal of Environmental Science and Technology 4:145-148.
3. Adriano, D.C. (2001): Trace elements in terrestrial environments: Biochemistry, bioavailability and risks of metals. - Springer Verlag.
4. Al-Ami, M.Y., Al-Nakib, S.M., Ritha, N.M., Nouri, A.M., Al-Assina, A. (1987): Water quality index applied to the classification and zoning of Al-Jaysh canal, Bagdad, Iraq. - Journal Environmental Science and Health 22: 305-319.
5. Backman, B., Bodis, D., Lahermo, P., Rapant, S. Tarvainen (1997): Application of a groundwater contamination index in Finland and Slovakia. - Environmental Geology, 36: 55-64.
6. Davis, O.A., Allison, M.E., Uyi, H.S. (2006): Bioaccumulation of heavy metals in water, sediment and periwinkle (*Tympanotonus fuscatus* var *radula*) from the Elechi creek, Niger delta. - African Journal of Biotechnology 5: 968-973.
7. Deekay, S.N., Abowei, J.F.N., Alfred, Ockiya, J.F. (2010): Seasonal variation of some physical and chemical parameters of Luubara creek, Ogoni land, Niger Delta, Nigeria. - Research Journal of Environmental and Earth Science 2: 208-215.
8. Ebrahimpour, M., Mushrifah, I. (2008): Heavy metal concentrations in water and sediments in Tasik Chini, a freshwater lake, Malaysia. - Environmental Monitoring and Assessment 141: 297-307.
9. Edet, A.E., Offiong, O.E. (2002): Evaluation of water quality pollution indices for heavy metal contamination monitoring. A study case from Akpabuyo-Odukpani area, Lower Cross River Basin (Southeastern Nigeria). - GeoJournal 57: 295-304.
10. Elmaci, A., Teksoy, A., Topac, F.O., Huseyin, N., Kaya, S. (2007): Assessment of heavy metals in Lake Uluabat, Turkey. - African Journal of Biotechnology 6: 2236-2244.
11. Evans, D.H. (1987): The fish gill site of action and model for toxic effects of environmental pollutants. - Environmental Health Perspectives 71: 47-58.
12. Overall, N.C., MacFarlane, N.A.A. Sedgwick, R.W. (1989): The interactions of water hardness and pH with acute toxicity of zinc to brown trout, *S. trutta* L. - Journal of Fish Biology 35: 27-36.
13. Glenn, S.S., Sia, S., Kristine, J.M., Tessa, P.A., Elena, R., Josefina, D.J., Arnold, H. Glicria, R. (2009): Assessing heavy metals in the waters, fish and macroinvertebrates in Manila bay, Philippines. - Journal of Applied Sciences in Environment Sanitation 4: 187-195.
14. Karbassi, A., Bayati, G.R.N.-BI. (2005): Environmental geochemistry of heavy metals in a sediment core off Bushehr, Persian Gulf. - Iranian Journal of Environmental Health Science and Engineering 2: 255-260.
15. Khan, R., Israili, S.H., Mohan, A. (2005): Heavy metal pollution assessment in surface water bodies and its suitability for irrigation around the Neyveli lignite mines and associated industrial complex, Tamil Nadu, India. – Mine Water and Environment 24: 155-161.
16. Kumada, H., Kimura, S. Yokote, M. (1980): Accumulation and biological effects of Cd in rainbow trout. - Bulletin of Japanese Society of Scientific Fisheries, 46: 97-103.
17. Mohan, S.V., Nithila, P., Reddy, S.J. (1996): Estimation of heavy metal in drinking water and development of heavy metal pollution index. - Journal of Environmental Science and Health 31: 283-289.
18. Moore, J.W. (1991): Inorganic contaminations in surface water. - Sprenger Verlag, New York.
19. Norris, R.H., Lake, P.S. (1984): Trace metal concentrations in fish from the South Esk River, North Eastern Tasmania, Australia. - Bulletin of Environmental Contamination and Toxicology 33: 348-354.
20. Osborne, L.L., Iredale, D.R., Wrona, F.J. Davies, R.W. (1981): Effects of Chlorinated sewage effluents on Fish in the Sheep River, Alberta. – Transactions of the American Fisheries Society 110: 536-540.
21. Panday, J., Shubhashish, K. Richa, P. (2010): Heavy metal contamination of Ganga river at Varanasi in relation to atmospheric deposition. - Tropical Ecology 51: 365-373.
22. Parsad, B. Bose, J.M. (2001): Evaluation of heavy metal pollution index for surface and spring water near a limestone mining area of the lower Himalyas. - Environmental Geology 41: 183-188.
23. Reddy, S.J. (1995): Encyclopedia of environmental pollution and control. - Environmental media, Karela, India.
24. Sasmaz, A., Obek, E., Hasar, H. (2008): The accumulation of heavy metals in *Typha latifolia* L. grown in a stream carrying secondary effluent. - Ecological Engineering, 33: 278-284.
25. Siegel, F.R. (2002): Environmental geochemistry of potentially toxic metals. - Springer, Berlin.
26. Simpson, W.R. (1982): Cadmium in the marine environment. - Progressive Oceanography 10: 1-70.
27. Tay, C.K., Asmah, R. Biney, C.A. (2009): Trace Metal Levels in Water and Sediment from the Sakumo II and Muni Lagoons, Ghana. - West African Journal of Applied Ecology 16: 75-94.
28. Westerhagen, H., Von, V., Dethletsen, Rosental, H. (1980): Correlation between cadmium concentration in the water and tissue residue levels in Dab, *Limanda limanda*, L. and Plaice, *Pleuronectes platessa*, L. - Journal of Marine Biological Association UK 60: 45-58.
29. Zhou, H.Y., Cheung, R.Y.H., Chan, K.M., Wong, M.H. (1998): Metal concentrations in sediments and *Tilapia* collected from inland waters of Hong Kong. - Water Research 32: 3331-3340.

AUTHORS

**First Author** – Onkar Singh Brraich , Department of Zoology and Environmental Sciences, Punjabi University, Patiala-147002, India, [singhonkar@yahoo.com](mailto:singhonkar@yahoo.com)

**Second Author** – Sulochana Jangu, Department of Zoology and Environmental Sciences, Punjabi University, Patiala-147002, India, [sulochanajangu@gmail.com](mailto:sulochanajangu@gmail.com)

**Correspondence Author** Sulochana Jangu (09815556209)



Table 1. Heavy metal analysis of surface water of Harike wetland

Site	Season	Copper (Cu)	Iron (Fe)	Lead (Pb)	Cadmium (Cd)	Zinc (Zn)	Nickel (Ni)	Chromium (Cr)	Manganese (Mn)	Beryllium (Be)	Cobalt (Co)
Harike wetland	Winter	0.283	2.231	0.536	0.026	1.003	-	0.042	-	0.054	0.021
	Spring	0.10	0.032	0.7021	0.034	-	-	0.251	-	-	0.0067
	Summer	0.5435	1.895	-	-	0.907	0.042	0.217	0.086	-	-
	Autumn	0.116	1.067	0.907	0.011	0.872	0.0289	-	0.0319	0.239	-
Mean±S.D.		0.26±0.20	1.30±0.98	0.53±0.38	0.01±0.01	0.69±0.46	0.01±0.02	0.12±0.12	0.02±0.04	0.07±0.11	0.0021±0.067
WHO Permissible Limits (mg/l)		0.02	1	0.05	0.005	1	0.02	0.05	0.05	-	-

Table 2. Correlation matrix among different heavy metals in surface water of Harike wetland

	Copper	Iron	Lead	Cadmium	Zinc	Nickel	Chromium	Manganese	Beryllium	Cobalt
Copper	1									
Iron	0.70424	1								
Lead	-0.96668	-0.53932	1							
Cadmium	-0.68919	-0.49035	0.54835	1						
Zinc	0.52997	0.91237	-0.30033	-0.64405	1					
Nickel	0.58924	0.28634	-0.47913	-0.97532	0.47187	1				
Chromium	0.2851	-0.41707	-0.51357	0.10069	-0.66139	0.0093644	1			
Manganese	0.78644	0.36039	-0.72542	-0.94171	0.41907	0.94922	0.23868	1		
Beryllium	-0.47614	-0.021724	0.67051	-0.2259	0.37008	0.23813	-0.8256	-0.073327	1	
Cobalt	-0.099122	0.37376	0.095811	0.62507	0.12961	-0.78142	-0.26087	-0.6775	-0.26574	1

Table 3. Standard used for the indices computation.

	W	S	I	MAC
Cu	0.001	1000	2000	1000
Fe	0.005	300	200	200
Pb	0.7	100	10	1.5
Cd	0.3	5	3	3
Zn	0.0002	5000	3000	5000
Ni	0.05	20	20	20
Cr	0.02	50	50	50
Mn	0.02	100	500	50

W weightage (1/MAC)

S Standard permissible in ppb

I Highest permissible in ppb

MAC Maximum admissible concentration/upper permissible (Adapted from Siegel, 2002)

Table 4. Evaluation indices.

<b>Parameter</b>	<b>C<sub>d</sub></b>	<b>HPI</b>	<b>HEI</b>
<b>Cu</b>	0.74	174	0.26
<b>Fe</b>	5.5	1100	6.5
<b>Pb</b>	352.33	577.77	353.33
<b>Cd</b>	2.33	350	3.33
<b>Zn</b>	0.862	115.5	0.13
<b>Ni</b>	0.5	1000	0.5
<b>Cr</b>	1.4	7000	2.4
<b>Mn</b>	0.6	120	0.4
<b>Maximum</b>	0.5	7000	353.33
<b>Minimum</b>	352.33	115.5	0.4
<b>Mean</b>	44.85	1304.65	45.85

# Adjustment among M.Tech students of Banasthali University

Shweta Nema\*, Dr. Suvidha\*\*, Prof. Indu Bansal\*\*\*

\*Research Scholar Department of Home Science Banasthali University

\*\*Associate Prof. Faculty of Home Science Banasthali University

\*\*\* Dean Faculty of Home Science Banasthali University

**Abstract-** The study consists from adjustment among M.Tech students of Banasthali University. The sample 67 girls were selected from Banasthali hostel. The measure of Bell's Adjustment Inventory developed by Dr. R.K. Ojha (1934) was used. Data analysis was done by using Karl Pearson correlation statistical test. Findings of the study revealed that the significant positive correlation between all variables at the level of (0.01).

**Index Terms-** Home, health, social, emotional Adjustment, hostel girls.

## I. INTRODUCTION

Young adulthood is a period of adjusting to a new pattern of life and new social expectations. It is an age when one tries to settle down, an age when one faces a lot of problems still trying to adjust to the newly acquired lifestyle. At the same time young adults also carry certain rigid values from their adolescence which might create some conflict in their minds. Rigidity is a difficult term to define and has been used to describe behaviors characterized by the inability to change habits, attitude, set and discriminations. Adult would have to make major changes in their social adjustments as developing new relationships is important and is the main element of social adjustment. It is a time when person is expected to make several types of adjustments to live life successfully. (Paranmeswaran & Beena, 2004) "Defined adjustment is a process which a living organism acquires in a particular way of acting or behaving or changes an existing form of behavior or action."

As for as the adjustment of college student is concerned (Gerdes & Mallinckrodt, 1994) "The shift between high school and colleges can be challenging and many changes occur in emotional, social and academic adjustment. Adjustment difficulties, loneliness and depression are much more common now a day among college students than their peers who are not in college. In the modern society, life is becoming very complex & conflicting day by day. If a person is well adjusted only then one can survive without psychological stress which may result in maladjustment. Hence adjustment is very important in one's life." (United States Department of Education, 2001) "In a study concluded that college students are at risk for failure to graduate." (Belch, Gebel and Mass, 2001) also noticed that "academic performance made a difference in the retention of students also they found that more adjusted students in the institution have average & more success in college and life in general."

## II. MAJOR ASPECTS OF ADJUSTMENT AMONG COLLEGE STUDENTS

### A. Home Adjustment

Home promotes satisfaction and security. The degree of adjustment of an individual exhibits in her behavior with others. So is the ease with home adjustment, if one is well adjusted in home, most probably she must has been well adjusted socially because the adjustment in different fields of life are related and effective to each other.

So the home adjustment of students should be healthy one. The reflection of well and poor adjusted students hoe is clearly seen in their behavior with their class fellows. A well adjusted child will be more cherished and happy in comparison to the poor-adjusted.

### B. Health Adjustment

Health also plays prime role in the development of one's personality. Sound health is the source of satisfaction and adjustment. The person should be physically as well as mentally healthy.

Physically and mentally healthy person always feels herself well adjusted in society then the unhealthy one. An unhealthy person always cries for her weakness and could not participate fully with others. Physically and mentally healthy person will be less guided by emotions. This is known as the roof of personality. Such physically and mentally healthy person feels themselves secure and content in their life.

### *C. Social Adjustment*

It is generally said that man is a social animal. In reference to this we may say that a person develop his personality in her social environment, she tries to mold herself on according to her society's social values and ideals and to achieve these values and ideals her activities and behaviors will be same as other members of her society, in which she lives and where her social needs and desires are satisfied. And then she feels herself socially adjusted.

Area of social adjustment is influenced by social maturity of the person. Maturity in social relationship means to establish good relations with family neighbors, playmates, class fellows, teachers and other members of the society.

### *D. Emotional Adjustment*

A person is emotionally adjusted if she expresses emotion in a proper situation in a proper form. An emotionally stable person may be well adjusted and emotionally unstable conditions causes mental disorders and maladjustment. Emotional adjustment is essential for creating a sound personality. It is the roof of personality adjustment and physical, intellectual mental and esthetical adjustments are possible when emotional adjustment is made.

Emotional adjustment is followed by the social adjustment. Such person's activities are socially beneficial and individually helpful in maintaining effective personality.

## III. LITERATURE REVIEWS

Similar conclusions were drawn from another study by Nataraj, (1968) "using Bells' adjustment inventory on emotionally adjusted and emotionally mal adjusted adolescent college girls."

A comparative study of adjustment pattern of post graduate arts and science students was done by (Satappan and Kuppan, 1980) "They took 50 students each and administered Saxena adjustment inventory (it measures general adjustment and adjustment in 5 specific areas namely Home, Health, Emotions, Social and college life) Humanities students were found to be better adjusted generally and socially than science students."

Kumaraswamy, (1990) in a study of "psychological problems of college students of a 100 medical students, it was found 26% having Psychological distress and 31% anxiety and Depression. It is a known fact that Anxiety, Depression and Stress are common among college students." (Sharma, 2012) "60students (30 boys +30 girls) were purposively selected in the study. Study reveals that although college-going students face few problems regarding their adjustment in college environment. The study underlines that only an adjustable person can make his life successful that is why, college authorities, parents, should pay attention to minimize the adjustment problems of college going students." (Gerdes & Mallinckrodt, 1994) found that "the shift between high school and colleges can be challenging and many changes occur in emotional, social and academic adjustment. Adjustment difficulties, loneliness and depression are much more common now a day among college students than their peers who are not in college. In the modern society, life is becoming very complex & conflicting day by day. If a person is well adjusted only then one can survive without psychological stress which may result in maladjustment. Hence adjustment is very important in one's life."

Sultana Begum and Bhattacharyya, (2009-2010) "Adjustment and anxiety among 100 girls students living in hostels (Group-I) in Kolkata and compare them with those living with parents (Group-II). Significant difference was found between the two groups in the areas of health and educational adjustment. The result of Anxiety Test revealed significant difference in the dimensions of guilt proneness and self control." (Kumaraswamy, 2013) it focuses "stress among college students, nature of psychiatric morbidity, emotional problems and adjustment, psychological problems of college students."

Sharma and Saini, (2013) "A sample of 100 students (50 Boys and 50 Girls) was selected of Jammu region. Study revealed that girls are average in the dimensions of health and social adjustment and unsatisfied in emotional areas. Boys are average in the dimensions of social adjustment and unsatisfied in health and emotional areas. There is no significant they differ significantly difference between health, social and emotional adjustment of girls and boys. There is a significant difference between health and emotional adjustment of urban and rural college students but they do not differ significantly in social adjustment." (Nanda, 2001) "Conducted a study on 280 urban and rural college students on health adjustment and reported that urban students had better health than the rural students." (Sujatha et.al, 1993) "Studied social adjustment problems among urban & rural college students and reported a significant difference in the social adjustment of urban and rural college students."

## IV. OBJECTIVE

1. To study the home, health, social, emotional and overall adjustments of M.Tech students of Banasthali University
2. To study the correlation between home, health, social, emotional and overall adjustments among M.Tech students of Banasthali University.

## V. HYPOTHESIS

There is no correlation between home, health, social, emotional and overall adjustment of the post graduate students.

VI. METHODOLOGY

A. Sample

Study was consisted 67 girls to M.tech randomly selected from Banasthali University Rajasthan as sample.

B. Tools

Bell's Adjustment Inventory developed by Dr. R.K. Ojha (1934) was used for the purpose of selection of data. This inventory includes four parts viz. home, health, social and emotional adjustment. The inventory is totally negative inventory. Each part has 35 questions, which are answered in 'Yes' and 'No'. For each 'Yes' responses 1 score is to be given and are not concerned to the 'No' responses. When an individual answer in 'Yes' it indicates his/her difficulties, if he/she answers as 'No' it indicates that the individual has no difficulty in that particular area.

C. Statistical analysis

In this study Karl Pearson correlation test was used for statistical analysis.

VII. METHODOLOGY

**Table 1 Different aspects of the Post Graduate Students adjustment**

Respondences N=67

Aspects of adjustment	Percentage of respondents	Mean	Std. Deviation
Home	19.02	7.31	3.304
Health	17.00	6.54	3.594
Social	38.81	14.93	3.779
Emotional	25.15	9.67	5.212

Table 1 depicts the home (M=7.31, SD=3.304 and percentage 19.02%) health (M=6.54, SD= 3.594 and percentage 17.00%) social (M=14.93, SD= 3.779 and percentage 38.81%) emotional (M=9.67, SD=5.212 and percentage 25.15%). The result shows that post graduate girls have a more problem in social, emotional and home adjustment.

**Table 2 Correlation adjustment of the Post Graduate Students (Karl Pearson correlation)**

Sr. No.	Areas	Home	Health	Social	Emotional
1	Home	-	0.273*	0.473**	0.662**
2	Health	-	-	0.094	0.501**
3	Social	-	-	-	0.336**
4	Emotional	-	-	-	-

\*\* Correlation is significant at the 0.01 level (2-tailed).

Table 2 Result depicts the girl's home and health correlation is 0.273, home and social correlation is 0.473, home and emotional correlation is 0.662, health and social correlation is 0.094, health and emotional correlation is 0.501, social and emotional correlation is 0.336. Results shows that the positive significance correlation between all variables. These variables are effect on girl's adjustment. section is not required. Although a conclusion may review the main points of the paper, do not replicate the abstract as the conclusion. A conclusion might elaborate on the importance of the work or suggest applications and extensions.

VIII. SUGGESTION FOR FUTURE RESEARCH

1. Same study can be conducted on a large sample.
2. It can be expand to more colleges for broader generalization.
3. Similar study can be conducted to make the comparison between boys and girls students.

REFERENCES

- [1] Begum A.S. and Bhattacharyya K. (2009-2010). *A comparative study on adjustment and anxiety of girls staying in hostel and girls living with parents* (Postgraduate Research Studies, J. D. Birla Institute, Department of Home Science). Retrieved from [www.jdbikolkata.in](http://www.jdbikolkata.in)
- [2] Sharma P. and Saini N. (2013). Health, social and emotional problems of college students. *IOSR Journal Of Humanities And Social Science (IOSR-JHSS)*, 14 Issue 5.
- [3] Kumaraswamy N. (2013). Academic stress, anxiety and depression among college students- A Brief Review. *International Review of Social Sciences and Humanities*, 5(1), 135-143.
- [4] Sharma R. (2012). Ego- strength in relation to adjustment of collage-going student. *Indian Streams Research Journal*, II(I).

AUTHORS

**First Author** – Shweta Nema, Research Scholar Department of Home Science Banasthali University, snmprj@gmail.com

**Second Author** – Dr. Suvidha, Associate Prof. Faculty of Home Science Banasthali University.

**Third Author** – Prof. Indu Bansal, qualifications Dean Faculty of Home Science Banasthali University.

**Correspondence Author** – Shweta Nema, Research Scholar Department of Home Science Banasthali University, snmprj@gmail.com



# Correlates of Home Health Social Emotional Adjustment among Adolescence Girls

Shweta Nema\*, Prof. Indu Bansal\*\*

\*Research Scholar Department of Home Science Banasthali University

\*\* Dean Faculty of Home Science Banasthali University

**Abstract-** The present study an attempt is made to assess the correlates of adjustment among adolescents student studying in 9th class in Banasthali University. A total sample of (N=167) adolescent students studying in Banasthali University were randomly selected in 2012-2013. They were administered Bell's Adjustment Inventory (1934) which measured adjustment of an individual in 4 areas (Home, health, social and emotional). The data were analyzed using descriptive statistics, t-test analysis and One-way ANOVA to find out the significance of difference between students with different levels of adjustment in various areas. Results revealed that the highly significant influence on home, health, social and emotional adjustment of adolescence students.

**Index Terms-** Home, health, social, emotional Adjustment, hostel girls.

## I. INTRODUCTION

Adolescence is a transitional period of life it's in between childhood and adulthood, during this period some important biological, psychological and social changes take place. It is a period of storm and stress. Adolescents have to adjust with their own changes in personality on one side and the changing socioeconomic environment on the other side. Some adolescents find its difficulties to adjust normally with changes and experience some problems, which are characterize of this developing stage.

It is concerned with the ability to cope effectively with his environment. According to Parameswaran and Beena (2004) "Adjustment is a process by which a living organism acquires a particular way of acting or behaving or changes an existing form of behavior or action. This adjustment is of two type's viz. adjustment to external conditions and adjustment becomes necessary, as a person grows older. Adjustment is a very significant factor in determining the degree of achievement of students."

Mahmoudi (2011) "a total of 100 adolescent students of 9th class studying in Shiraz city were randomly selected. Only home adjustment had significant influence over academic achievement. Emotional, social and health adjustments did not have significant influence over academic achievement of the sample studied." Bhaskar & Rudramma (2007) there is a significant relation between age of maturation and their adjustment pattern showing significant difference in social, emotional and overall adjustment at 11 (early) and 15 (late) years of age of maturation.

D'Souza & Gururaj (2001) "240 subjects were selected as a sampling from the 8th, 9th, and 10th standards, from two High schools of Mysore city, India. Shyness has no differential effect on home and health adjustment, however, there is a significant linear increase in the social, emotional and total maladjustment with the increase in the level of shyness i.e., higher the shyness higher the maladjustment in social and emotional adjustment of the students." Deb & Walsh (2012) "the social adjustment scores of school children who experienced violence, regardless of the nature of the violence, was significantly lower when compared with scores of those who had not experienced violence ( $p < 0.001$ ). Social adjustment was poorer for girls than boys ( $p < 0.001$ )."

Khan & Hassan (2012) "children of non-working mothers are more emotionally intelligent than children of working mothers. Children of working and non-working mothers show significant difference in self-awareness, empathy, self-motivation, emotional stability, managing relations, integrity, self-development and altruistic behavior. Children of non-working mothers have been found clear in their priorities, pay more attention to the worries and concerns of others. They are found to be friendly, sociable, helpful and skilful in dealing with people. They are found to be more responsible, more comfortable to novel ideas and new information. They face boldly good and bad situations. They are more aware of their weaknesses, are more co-operative, helpful, outgoing and democratic. They are better able to encourage people to take initiative. They can handle conflicts around them more intelligently than the children of working mothers. No significant difference was found in value orientation and commitment between children of working and non-working mothers."

## II. METHODOLOGY

### A. Objective

To find out the adjustment pattern

To find out the girls home, health, social and emotional adjustment.

**B. Delimitation**

To delimit a problem is to fix the boundaries of the piece of research work. The present is delimited in the following manner:

1. The present study was delimited to Banasthali University campus.
2. The study delimited to the 9th class girls of Banasthali University hostel.

**C. Population and Sample**

A total sample was 167 adolescents girls of 9th class were selected in two years. In 2012 randomly selected 105 girls and in 2013 selected 62 girls from Banasthali University hostel.

**D. Tools**

Bell's Adjustment Inventory developed by Dr. R.K. Ojha (1934) was used for the purpose of selection of data. This inventory includes four parts viz. home, health, social and emotional adjustment. The inventory is totally negative inventory. Each part has 35 questions, which are answered in 'Yes' and 'No'. For each 'Yes' responses 1 score is to be given and are not concerned to the 'No' responses. When an individual answer in 'Yes' it indicates his/her difficulties, if he/she answers as 'No' it indicates that the individual has no difficulty in that particular area.

**III. RESULTS AND DISCUSSION**

The result revealed that the correlates of home, health, social and emotional adjustments among adolescence girls are highly significance.

**Table-1:**

Mean-Values results are showing home, health, social and emotional adjustment of girls.

Areas	Mean	Std. Deviation	T	Sig. (2-tailed)
Home	7.78	2.926	34.359	.000**
Health	6.27	4.140	19.571	.000**
Social	16.46	3.474	61.232	.000**
Emotional	12.34	6.033	26.436	.000**
total	42.85	12.536	44.174	.000**

\*\* Significant at 0.01 level.

Table 1 showed that the highly significance level in home, health, social and emotional adjustment of girls. Girl's social adjustment (M = 16.46, SD = 3.474) emotional adjustment (M = 12.34, SD = 6.033) home (M = 7.78, SD = 2.926) health (M = 6.27, SD = 4.140).

**Table-2:**

One-way ANOVA results for home, health, social and emotional adjustment of girls.

	Sum of Squares	Df	Mean Square	F	Sig.
Between Groups	10696.096	3	3565.365	192.304	.000**
Within Groups	12310.719	664	18.540		
Total	23006.814	667			

Table 2 showed that the highly significance level at (.000\*\*) (F 192.304)

The results show that for school girls living in hostels social adjustment is the highest importance followed by their emotional adjustment, whereas home and health adjustments are lesser important. The reason for social adjustment to be of the highest importance is that because in hostels girls stay far away from their family and relatives. They spend most of their time with hostel-mates who come from different background and from different geographical parts. Students are very highly attached with mates and

seek the missing family environment and support from their friends. Due to the same reasons emotional adjustment is higher than home and health adjustment.

#### REFERENCES

- [1] Bhaskar, R. & Rudramma (2007). A study on the relationship between Age of maturation and adjustment pattern of adolescent girls in Mysore city. *J. Hum. Ecol.*, 21(1), 23-25.
- [2] D'Souza, L., Gururaj B. Urs (2001). Effect of shyness on the adjustment among high school students. *Pakistan Journal of Psychological Research*, 16(3-4).
- [3] Deb S. & Walsh K.M. (2012) Impact of physical, psychological, and sexual violence on social adjustment of school children in India. *School Psychology International*, 33(4), 391-415.
- [4] Khan M.A., Hassan A. (2012) Emotional intelligence of children of working and non-working mothers. *Researcher*, 4(4), 24-31.
- [5] Mahmoudi, A. (2011). Relationship between adjustment and academic achievement among adolescence students. *New York Science Journal*, 4(7).

#### AUTHORS

**First Author** – Shweta Nema, Research Scholar Department of Home Science Banasthali University, snmprj@gmail.com

**Second Author** – Prof. Indu Bansal, qualifications Dean Faculty of Home Science Banasthali University, indubnsl@yahoo.com

**Correspondence Author** – Shweta Nema, Research Scholar Department of Home Science Banasthali University, snmprj@gmail.com

# Review of literature on Correlates of Adjustment and Life Satisfaction among Middle Aged Married Couples

Shweta Nema\*, Prof. Indu Bansal\*\*

\*Research Scholar Department of Home Science Banasthali University

\*\*Dean Faculty of Home Science Banasthali University

**Abstract-** Middle age is one of the most important and researched period of human life. This is time of transitions in terms of family responsibilities, physical health changes, social interests and hobbies, etc. During this time couples relationship and adjustment also sees ups and downs. Till now many researchers have conducted studies on mid life adjustments and life satisfaction of middle aged married couples. This literature review is an attempt to examine the correlates which play important role in mid aged married couples adjustment and life satisfaction.

**Index Terms-** Home, health, social, emotional Adjustment, middle aged couples.

## I. INTRODUCTION

Middle age is characterized by competence, maturity, responsibility and stability. Middle age is a phase of transition when life pattern are revised in several ways to adapt to the new lifestyle. People at this stage want to enjoy the success of job, satisfaction derived from the family and social life as well as look forward to the success of their children, aging parents, the use of leisure time and plan for old age. Middle age is also considered the time of transference of authority, freedom and decision taking power to younger generation. This is the phase when people face entirely new set of challenges, expectation and liabilities and make several compromises. There may be many other aspects of life where one has to adapt to the changes like parenthood crises, coping with the untimely death of the spouse, etc. The occurrences of physical changes lead to changes in behavior also.

Middle adulthood is difficult to define in generalities, since there are variations in attitudes and behaviors at this point. According to Collin's Dictionary, Middle age is usually considered to occur approximately between the age of 40 and 60. While prominent social scientist, Erik Erikson, sees it ending a little later and defines middle adulthood as between 40 and 65. Middle adulthood begins with a transition (40-45), followed by a life structure (45-50). This structure is re-evaluated (50-55) and ends in a culminating life structure (55-60).

People have made consistent choices in certain directions and they often don't feel much freedom to significantly change their lives. Life crises often make the decision for them about change. People who feel cynical, disappointed, and angry about their lives tend to feel less optimistic, in this age. By this time the marriage has endured many shifts: from the more romantic, idealistic, and/or sexual emphasis, through the more prosaic, child-rearing, team-mate era. These previous sequences might have culminated in a relationship that is seasoned, stable and more satisfactory or more conflictual, tenuous and alienated than at any other time. In the absence of children, the conjugal bond, whatever its nature, will gain prominence.

## II. MID-AGE ADJUSTMENTS

It is important to adjust naturally with the transitions that occur both physically and mentally. There are challenges which should be met and coped with successfully. At this age it is good to look at the world with new prospective and changed interests. Some may find this adjustment stage really difficult and hard to cope with. Following are some of these important changes and adjustments which are faced in middle age.

### A. Physical / Health changes and adjustments

Loss and graying of hair, joint pain, osteoarthritis, osteoporosis, sagging muscles, appearance of wrinkles etc. are common phenomenon. These changes are natural and add gravity to looks and soberness of personality. The body system functions start to deteriorate in many, the people at this age may feel weak, have gastro-intestinal problems, suffer from insomnia, feel fatigue quite frequently, may have aches and pains, dental caries. With better medical and nutritional benefits of progressive societies, people feel much more connected and youthful than in the past.

Changes occur in the physiological and reproductive functioning of individuals. Loss of sex drive and sexual attractiveness may lead to depression in some people. This stage of life may manifest mood swings, depression, self-criticism, carelessness towards business, hostility. Some people develop interest in cultural activities for example: attend concerts, lectures, religious programs, reading, writing, painting, social work etc.

### *B. Intimacy and behavioral changes*

Marital satisfaction significantly relates to sexual satisfaction (Rahmani, Khoei, et al.2009). Individuals satisfied with their sexual relations tended to be satisfied and happy with their marriages, and better marital quality, in turn, helped reduce marital instability (Yeh, Lorenz, et al. 2006). Relationship satisfaction in men depended on health, physical intimacy and sexual functioning, while in women only sexual functioning predicts relationship satisfaction. Longer relationship duration predicted greater relationship happiness and sexual satisfaction for men (Heiman, Long et al. 2011). It is a period of acceptance of changes in virility in case of men and changes in fertility in case of women. A combination of anxiety and immaturity will lead the members of a couple to veer away from potentially conflict-laden subjects to more emotionally safe areas, so as to limit exchanges that cause arguments.

### *C. Changes in family relations and adjustment*

Marriage for certain families is synonymous with conflict. Chronic marital conflict at this stage may take the form of either hot arguments or silent distance. In the middle age period of life the spouses need to be closer in relationship with one another as compared to the early years of their married life. It is more difficult for women to cope up with the 'empty nest' period of their life. For some this may be a traumatic time when domestic responsibilities get minimized and one may find life monotonous. Boredom may be felt by many when there is no family oriented activity to perform. This is also time when menopausal symptoms set in; making it difficult to cope for some women.

At mid-age, children are now adults and parents are much older; needing more attention and extra assistance. These extended-care-giving demands, legally, financially and physically burden middle-age person. People at late middle adulthood stage also have to prepare for their own retirement.

### *D. Financial Adjustments*

Financial decisions arise against the backdrop of present family structure, current and perceived future needs, and competing demands placed on limited resources. Because of high demands on expenditure, balancing between the cost of living, paying for children's college education, developing resources like house, vehicles, arrange for marriage expenses of children and funding retirement, mid-adults feel like on a treadmill one can never get off.

### *E. Emotional Adjustment*

Emotional behaviors expressed by couples differ as a function of age, gender and marital satisfaction. The intensity of the middle-age intimacy crisis depends on the need-satisfaction of the relationship and the success achieved in the previous stages of intimacy. Older adults are biased toward the positive aspects of close relationships (Story, Nathan et. al 2007). Emotionally positive and responsive listening is one of the key to successful conflict resolution in marriage (Pasupathi, Monisha et. al.1999).

Carl Jung described the developmental task of the second half of life as the need to develop neglected inner resources and enrich the inner life which may result in the impoverishment of the inner life - the world of feelings, values and inner creativity. Failure to accept the changes may lead to serious traumatic situations like mental illness, use of drugs, addiction problems, alcoholism and at times suicide or homicide.

## III. LIFE SATISFACTION

Life Satisfaction is examined from the perspective of subjective well-being which refers to people's own evaluation of their lives. Apart from many challenges there are also significant benefits for the relationship in the middle age couples. Most of mid-adults now a day enjoy relatively good health and stabilized finances. This can be an opportunity for couples to pursue their own interests and to spend more time together and get more life satisfaction. Blanchflower and Oswald (2008) reported a significant quadratic effect of age on the happiness. Increased work demands, parenting adolescents, empty nesting, caring for aging parents, financial issues and retirement are just some of the concerns that increase stress during mid-life.

As far as middle age is concerned following parameters can be taken into account to explain the life satisfaction:

### *A. Mental*

A close marital relationship can be viewed as a significant interpersonal resource across the adult life span, representing potentially the most intimate type of emotional support throughout the adulthood years. Conjugal support is a multidimensional construct consisting of three factors: instrumental support, emotional support and confiding (Anderson & McCulloch 1993). Physical health of mid-adult couples is related with their nature of marital relationship (Bookwala 2005) over and above marital status.

### *B. Job*

Work satisfaction is at its peak in mid life years and the quality of work performance remains high, despite decline in some cognitive or physical skills. Patterns of work and work satisfaction do vary between men and women in middle adulthood. Men are more likely to improve their level of satisfaction in situations where change is possible. Women tend to withdraw or engage in complaining with co-workers. Still, women are better able to balance their dissatisfaction with areas of contentment.

### *C. Social*

In the process of socialization, adults prepare for a transition in role; it also involves identifying the new norms and expectations associated with such new social role as in-laws and grandparents. Adults of this age have more concern for laws, traditions, and cultural values and restricted acceptance against too rapid cultural change.

### *D. Marital*

It is likely that middle-aged partners' identification of successful problem-solving strategies contribute to the sense that they have control over their relationship. Skilled diplomacy (an approach to solving problems that involves confrontation of the spouse about an issue, followed by a period during which the confronting spouse works to restore harmony), considered an effective skill for marital problem-solving and is practiced more often by wives than by husbands.

### *E. Family*

Middle age also is referred as the mid-life “squeeze,” or the “sandwich generation” as family relationships in the middle age extend in both directions: relationships with grown children and relationships with aging parents. The family role at this stage involves maximum amounts of assistance given in both directions in the generational chain, as well as maximum responsibility for maintaining affection bonds.

## IV. LITERATURE REVIEWS

The investigator reviewed available literature to know more of middle age realities, which have been presented below-

1. Crohan, Antonucci et al. (1989) White and Black women and men at midlife (ages 40–64) were studied. The samples were drawn from two national surveys and included 186 White women, 202 White men, 254 Black women, and 169 Black men. Results indicate that job satisfaction is positively related to life satisfaction for all four groups and to happiness for White women and Black men. Personal income is positively related to perceived control for Black women and White men, and to life satisfaction for White women. Occupational status is positively related to perceived control for White and Black women; role stress is negatively related to life satisfaction among White men, and to happiness among Black women.
2. Libman and Eva (1989) a study describing the behavioral, cognitive, and affective aspects of sexual expression in a sample of aging married couples (50–80 yrs) is presented to illustrate how some previous methodological difficulties might be addressed. Findings identify some of the realities of sexuality in aging individuals and illustrate the complexities in the definition and evaluation of sexual expression and experience.
3. Anderson and McCulloch (1993) the sample consisted of 298 older marital dyads who participated in the Aging Couples Study. Confirmatory factor analysis techniques were used to examine conjugal support in a series of nested measurement models at the couple and individual levels. Two research questions were addressed: (a) the viability of conjugal support as a couple's construct, and (b) the dimensionality of social support within the marital dyad. Results showed that conjugal support was a husband/wife, rather than a couple, construct. Findings also showed that conjugal support was a multidimensional construct consisting of three factors: instrumental support, emotional support, and confiding. Moreover, husbands and wives perceived the dimensions of conjugal support differently.
4. D'Zurilla, et al. (1998) the results suggest that social problem-solving ability increases from young adulthood (ages 17–20) to middle-age (ages 40–55) and then decreases in older age (ages 60–80). Specifically, compared to younger adults, middle-aged individuals scored higher on positive problem orientation and rational problem solving, and lower on negative problem orientation, impulsivity/carelessness style, and avoidance style. Compared to older adults, middle-aged individuals scored higher on positive problem orientation and rational problem solving. Some age differences were specific to one gender. Across age groups, gender differences were found on positive problem orientation and negative problem orientation. Within the young adult group, gender differences were also found on impulsivity/carelessness style.
5. Shek (1999) perceived health status in 378 Chinese married couples. Results showed that marital adjustment and marital satisfaction were concurrently related to midlife crisis symptoms, life satisfaction, and perceived health suggest that the relationships between marital quality and health measures are bidirectional in nature. While marital quality predicted changes in midlife crisis symptoms in husbands, but not in wives, marital quality predicted changes in perceived health status in wives, but not in husbands. Results also showed that mental health influenced the marital adjustment of the wives, but not the husbands, over time.
6. Pasupathi, Monisha et al. (1999) observed 79 younger and older, happily and unhappily married couples, discussing conflicts. They coded listening behaviors indicative of attention and comprehension (responsiveness) as well as those expressing



emotions. It was expected that older married couples would display lower frequencies of responsive listening behaviors than middle-aged couples. Results provide conditional support for this hypothesis.

7. Skowron E. A. (2000) One hundred and eighteen couples living in a large metropolitan Area were solicited to participate in the study. The mean age of Women participants was 46.72 years and for men, 48.56 years. This American study based on couples' levels of differentiation explained substantial variance in marital adjustment 74% of variance in husband marital adjustment scores and 61% of variance in wife marital adjustment scores were accounted for by couple differentiation of self-scores. Greater husband emotional cutoff uniquely accounted for husband and wife marital discord. Contrary to family systems theory, actual couples were no more similar on differentiation than were randomly matched couples. Finally, greater complementarities among couples along the specific dimensions of emotional cutoff and emotional reactivity predicted greater marital distress.
8. Kashiwagi, Hirayama (2003) the purpose of this study was to investigate recent changes in marital norm and reality in middle-aged couples, and how marital reality, as perceived by oneself, was associated with their demographic variables, as well as their marital satisfaction. Participated 277 pairs of middle-aged, nuclear-family couples. Main findings were as follows. First, factor analysis of marital reality variables extracted three factors: love each other, respect for the husband's life style, and respect for wife's life style. Second, concerning the wife's education and income, 'respect for the wife's life style' was highest among highly educated double income couples. Third, 'love each other' was the most important predictor of marital satisfaction for both husbands and wives. Finally, 'respect for the husband's the life style' was associated with husband's satisfaction, while that for the wife's was not with wife's marital satisfaction.
9. Bookwala (2005) in US based study on 729 respondents suggested that marital quality indices accounted for a significant amount of explained variance in physical health. Most notably, higher levels of negative spousal behaviors uniquely contributed to physical health, predicting more physical symptoms, chronic health problems, and physical disability, and poorer perceived health. The occurrence of negative spousal behaviors was consistently associated with poorer physical health.
10. Myers and Madathil (2005) administered Marital satisfaction and wellness questionnaire on forty-five individuals (22 couples and 1 widowed person) living in arranged marriages in India. The data were compared with existing data on individuals in the United States living in marriages of choice. Differences were found in importance of marital characteristics, but no differences in satisfaction were found. Differences were also found in 9 of 19 wellness scales between the two groups.
11. White and Myers (2006) women (N = 224) between 35 and 65 years old participated in a study that examined the relationship among chronological age, subjective age, wellness, and life satisfaction. Women whose subjective age was less than or equal to their chronological age reported greater wellness; total wellness was a significant predictor of life satisfaction.
12. Yeh, Lorenz et al. (2006) based their study on 283 married American couples, to examine the causal sequences among three constructs for husbands and wives separately. Results of cross-lagged models, for both husbands and wives, provided support for the causal sequences that proceed from sexual satisfaction to marital quality, from sexual satisfaction to marital instability, and from marital quality to marital instability. Initially higher levels of sexual satisfaction resulted in an increase in marital quality, which in turn led to a decrease in marital instability over time. Effects of sexual satisfaction on marital instability appear to have been mediated through marital quality.
13. Schmitt, Kliegel and Shapiro (2007) in a research based on 588 married women and men in middle and old age in Germany examined age and gender differences in the role of socio-economic status, personality, and marital interaction as predictors of marital satisfaction. Results showed that i) socio-economic factors and personality played a minor role in predicting marital satisfaction, and ii) a high quality of dyadic interaction was particularly important for the marital satisfaction of women.
14. Lavalekar (2007) the research aims at exploring and comparing the marital satisfaction and emotional intelligence of people between age 25-65. A fairly representative data of 316 respondents was collected from Maharashtra, India. The analysis indicates a significant gender difference on certain areas of emotional intelligence, namely, openness to criticism, self management and empathy. A significant gender difference is also noted on two areas of marital satisfaction, namely, sexual relations and sharing household responsibilities, which can be traced to the socio-cultural influences. This has helped in understanding the relationship of gender with core traits of one's emotionality, which influence the marital relationship.
15. Henry, Nancy et al. (2007) examined age differences in positive (e.g., warm) and negative (e.g., hostile) characteristics of marital interactions between middle-aged and older couples and their association with marital satisfaction by age. Spouses'

perception of partners' positive and negative behavior during marital interaction was assessed in general following disagreement and collaborative tasks. Older individuals reported higher marital satisfaction and perceived their spouse's behavior as less negative in general and more positive across all contexts than middle-aged individuals. Perceptions of partners' negative behavior in general and of both positive and negative behavior in the disagreement task were more closely associated with marital satisfaction for older spouses than for middle-aged spouses.

16. Story, Nathan et al. (2007) this American study based on 270 middle-aged (40-50 years old) and older (60-70 years old) couples who discussed a marital disagreement and completed an errand task. The results are consistent with theories of emotion regulation, such as socio emotional selectivity theory, that suggest that older adults are biased toward the positive aspects of close relationships.
17. Shiota and Levenson (2007) the present study examined the relationship between similarity in Big Five personality factors and initial levels and 12-year trajectories of marital satisfaction in long-term couples, who were in their 40s and 60s at the beginning of the study. Across the entire sample, greater overall personality similarity predicted more negative slopes in marital satisfaction trajectories. In addition, spousal similarity on Conscientiousness and Extraversion more strongly predicted negative marital satisfaction outcomes among the midlife sample than among the older sample. Results are discussed in terms of the different life tasks faced by young, midlife, and older adults, and the implications of these tasks for the "ingredients" of marital satisfaction.
18. Blanchflower and Oswald (2008) presented data on 500,000 randomly sampled Americans and West Europeans, controlling for cohort effects. Holding other factors such as demographic variables and income constant, it showed that a typical individual's happiness reaches its minimum -- on both sides of the Atlantic and for both males and females -- in middle age. Second, evidence provided for the existence of a similar U-shape through the life-course in East European, Latin American and Asian nations. Third, a U-shape in age is found in separate well-being regression equations in 72 developed and developing nations. Fourth, using measures that are closer to psychiatric scores, it documented a comparable well-being curve across the life cycle.
19. Rahmani, Khoei et al. (2009) Sample was used 292 married men, and women aged 19-58 yr from selected hospitals in Tehran while visiting their hospitalized relatives. Marital satisfaction significantly relates to sexual satisfaction ( $P= 0/00$ ). There was also a significant relation between sexual satisfaction and the following variables: age difference of couples ( $P= 0.04$ ), length of marital life ( $P= 0.05$ ), and a drug abused participant ( $P= 0.007$ ). Of these variables, only the age difference of couples significantly relates to marital satisfaction (0.00). Findings suggest that sexual satisfaction plays a seminal role in marital satisfaction of Iranians.
20. Seider, Hirschberger et al. (2009) examined the California study on middle-aged and older couples ( $N_{154}$ ) engaged in a 15-min conflict conversation during which physiology and emotional behavior were continuously monitored. Verbatim transcripts of the conversations were coded into 2 lexical categories: (a) we-ness (we-words), pronouns that focus on the couple; (b) separateness (me/you-words), pronouns that focus on the individual spouses. Analyses revealed that greater we-ness was associated with a number of desirable qualities of the interaction (lower cardiovascular arousal, more positive and less negative emotional behavior), whereas greater separateness was associated with a less desirable profile (more negative emotional behavior, lower marital satisfaction). In terms of age differences, older couples used more we-ness words than did middle-aged couples. Further, the associations between separateness and marital satisfaction were strongest for older wives. These findings indicate that the emotional aspects of marital quality are expressed in the natural language of couples engaged in conversation.
21. Karahan (2009) administered to 122 Turkish couples who volunteered to participate. The 40 couples with the worst test scores were randomized into study and control groups. No differences in the test scores were determined between the two groups before the start of the program ( $P > 0.05$ ). After attending the program, the test scores of the study group were better in total than those of the control group ( $P < 0.001$ ). Benefits are retained at 3 and 6 months following ( $P = 1$ ).
22. Hansen et al. (2009) study explores and distinguishes links between parental status (childless persons, parents with residential children, and empty nest parents) and a range of psychological well-being outcomes in midlife and old age ( $N=5189$ ). Separate outcomes into cognitive (life satisfaction and self-esteem) and affective (positive and negative affect, depression, loneliness) components. Parental status has a net effect on cognitive well-being among women, as childless women report significantly lower life satisfaction and self-esteem than both mothers with residential children and empty nest mothers. Among men, parental status is unrelated to any of the well-being aspects. Parental status effects are not modified by age, marital status, and education. The results demonstrate the importance of investigating the effect of parental status and other objective circumstances on a range of psychological well-being outcomes. Furthermore, the results reviewed and presented

indicate somewhat more positive effects of parenthood in the Nordic countries than in the U.S., highlighting the role of social policies in shaping the impact of parental status on well-being.

23. Brockmann (2009) Overall, 6,568 men and 7,038 women, or 146,977 person-years, are included in our analysis. The mean age is 45 years, 8,645 respondents are between 30 to 60 years old. (Un)happiness in midlife is more strongly determined by gender-specific occasional influences and individual characteristics. Both define objective and subjective returns of professional and personal life investments. These social investment decisions date back to early adulthood and bear a high risk of failure during midlife. Unforeseen consequences and long-term private and professional commitments make it costly to adjust, but at the same time new investments may pay off in a pro-longed future. This dilemma turns many middle-aged people into “frustrated achievers”.
24. Alder (2010) conducted study to determine whether there is a relationship between marital satisfaction and the independent variables of age, education level and courtship length. Respondents (N = 60) were required to complete surveys online regarding their experiences in their marriages. Results indicated that there was not a statistically significant relationship between marital satisfaction, age, education level and courtship length. However, there was a negative correlation between post-engagement courtship and dyadic adjustment, indicating that, as length of engagement increases, marital adjustment decreases.
25. Huber, Navarro et al. (2010) participants included 239 couples, who were between the ages of 45 and 65. The results showed significant positive relationships existed between the criterion variables (rebuilding the marriage relationship and maintaining kin ties with older and younger generations) and the predictor variables (adaptive appraisal, compensating experiences, and social support), thus providing support for the position that in the face of the developmental challenges encountered relative to midlife marriage, higher levels of the primary protective factors contributing to family resilience are related to greater levels of mastery of the developmental tasks associated with midlife marital satisfaction.
26. Windsor and Butterworth (2010) age group differences in self-reported supportive, aversive, ambivalent, and indifferent partner relations were examined in a large sample of midlife (aged 40-44 at baseline, n = 1,719) and older (aged 60-64 at baseline, n = 1,675) married and partnered adults assessed on two occasions 4 years apart. Older adults, particularly older men, were more likely to rate their relationship as supportive and less likely to rate their relationship as aversive relative to midlife adults. Midlife adults were more likely to provide ambivalent or indifferent assessments (as opposed to supportive assessments) of their relationship relative to older adults. Results are discussed in the context of possible developmental changes in interpersonal and intimate relations occurring in middle and older adulthood.
27. Seider and Herschel (2011) this study examined middle-aged (N = 82) and older (N = 74) couples, in California, engaged in a 15-minute conflict conversation to determine how discrete emotion sequences between spouses were related to marital satisfaction. It further examined whether age and gender moderated the relationships between discrete emotion sequences and marital satisfaction. The study focused on discrete emotion sequences initiated by three antecedent emotions (anger, contempt and sadness) previously associated with distressed marriages. Results revealed significant associations between discrete emotion sequences and marital satisfaction for 11 of the 39 discrete emotion sequences examined. The findings indicated that the relationships between discrete emotion sequences and marital satisfaction did not consistently differ as a function of age, but when they did, they tended to be stronger for older couples. This study revealed important differences in how discrete emotion sequences relate to marital satisfaction.
28. Berg, Cynthia et al. (2011) this study based on 300 middle-aged and older couples who completed measures of perceptions of collaboration, cognitive ability, marital satisfaction, an errand task and judged their spouse's affiliation. Older adults (especially men) endorsed cognitive compensation and interpersonal enjoyment and reported using collaboration more frequently than middle-aged adults. Greater need for cognitive compensation was related to lower cognitive ability only for older wives. Greater marital satisfaction was associated with greater interpersonal enjoyment. These two functions related to reports of more frequent use of collaboration and perceptions of spousal affiliation in a collaborative task.
29. Kouros and Cummings (2011) collected information from 296 America based couples on marital satisfaction, marital conflict and depressive symptoms annually reported for three years. Results suggested that for husbands, transactional relations between marital satisfaction and depressive symptoms identified: high levels of depressive symptoms predicted subsequent decreases in marital satisfaction and decreased marital satisfaction predicted subsequent elevations in depressive symptoms over time. For wives, high levels of marital conflict predicted subsequent elevations in depressive symptoms over time. Cross-partner results indicated that husbands' depressive symptoms were also related to subsequent declines in wives' marital satisfaction.

30. Heiman, Long et al. (2011) interviewed 1,009 heterosexual couples 40-70 year old men and their female partners from the United States, Brazil, Germany, Japan and Spain from the Kinsey Institute who were married or have been living together for at least one year. Results from the study found that men were more likely than women to report being happy in their relationship. Women, however, reported that they were more satisfied with their sexual relationship.
31. Pinto and Neto (2012) examined the Participants numbered 193 with a mean age of 51.64. Scores from the SWSLS have favorable psychometric properties among which Cronbach's alpha was 0.83. As expected no gender differences regarding the satisfaction with sex life were found. Characteristics indicative of the quality of a relationship (Eros, commitment, sexual desire, and romantic loneliness) were related to the level of sexual satisfaction. Measures of well-being (satisfaction, life satisfaction, and self-esteem) were also related to sex life satisfaction.
32. Goel and Narang (2012) marital adjustment, mental health and frustration reactions in males and females of middle age, from Delhi, India. The sample comprised of 150 males and 150 females (n=300) which are bank employees, doctors and lecturers, within the age range of 40-55 years. It was seen that Females showed high level of recreational adjustment as compared to males but males were having better group oriented attitude than females.
33. Moosavi (2012) results showed that family functioning; marital adjustment and intimacy in two groups (middle-aged and young spouses) were not significant. For subjects compared by educational status, their mean in family functioning and marital adjustment were significant, but on the intimacy scale they were the same. Also evident was significant positive correlation between marital adjustment and intimacy (0.71), between family functioning and marital adjustment (0.68) and between family functioning and intimacy (0.50), (0.01).
34. Fatimah (2012) the quality of marital satisfaction to three dimensions which are Marital Relationship, Marital Adjustment and Marital Intimacy. 1,213 questionnaires returned are distributed across West Malaysia. The result shows that marital relationship is the first priority since this dimension has the lowest level of satisfaction, followed by marital intimacy then marital adjustment as the third priority needs to be improved.
35. Lee, Zarit et al. (2012) a sample of 197 middle-aged couples reported support they gave to and received from their parents (n = 440). Results indicated that couples provided more total support to and received more from their parents as a function of number of living parents, but the amount of support each parent received ('parent-adjusted support') was lower when there were more living parents. The amount of support given to and received from parents had no association with the couple's marital satisfaction, but discrepancies in support given to and received from parents did have a significant association with marital satisfaction. Husbands who gave more support to their living parent(s) than their wives reported lower marital satisfaction. A similar effect on marital satisfaction was found for wives who gave more support to their living parents than their husbands. These findings contrast with care giving studies where amount of support affected marital satisfaction and suggest that inequalities in involvement with parents may be a critical dimension in marriages of midlife adults.
36. Fiori and Denckla (2012) examine the association between various aspects of social support and depressive symptoms separately among men and women. A sample of 6,767 middle-aged adults from one wave of the Wisconsin Longitudinal Study (1992-1993), results found that the receipt of emotional support was associated with mental health in women only, whereas the provision of emotional and instrumental support was associated with mental health among men and women, but with varying patterns.
37. Tianyuan and Fung (2012) the present study assessed partner discrepancies and marital quality in 56 couples, 20-79 years old. Results indicated that husbands' partner discrepancies, but not wives', were found to mediate the curvilinear age differences in marital quality. The results suggest that adjusting cognition about the partner is essential to the typically higher marital quality in later adulthood. The results also suggest that the level of comparison standards and the specific domain of partner characteristics should be considered in future studies.
38. Dogra and Stathokostas (2012) Sedentary behavior is emerging as an important risk factor for poor health. Physical activity has proven to be important in determining overall successful aging (SA) among older adults; however, no data exists on the influence of sedentary behavior on SA. The purpose of this analysis was to determine whether there is an association between sedentary behavior and successful aging, independent of physical activity levels. 9,478 older (M = 4,245; F = 5,233) and 10,060 middle-aged (M = 4,621; F = 5,439) adults from the Healthy Aging cycle of the Canadian Community Health Survey were analyzed. Among older adults, compared to those who were sedentary (4 hours or more/day), those who were moderately (2-4 hours/day) and least sedentary (<2 hours/day) were 38% (OR: 1.38; CI: 1.12-1.69) and 43% (OR: 1.43; CI: 1.23-1.67) more likely to age successfully, respectively. Among middle-aged adults, those who were least sedentary were 43% (OR: 1.43; CI: 1.25-1.63) more likely to age successfully. These novel findings suggest that sedentary activities are significantly associated with lower odds of SA among middle-aged and older adults, potentially in a dose-dependent manner.

39. Zainah et al. (2012) subjects for this study were 423 married couples the age group between 21-30 years, 31–40 years and 41–50 years. Results indicated significant differences in marital satisfaction based on the length of marriage and income. This study suggests that marriage counseling, with an emphasis on promoting awareness in marital happiness and satisfaction, would be helpful in addressing marital problems in married couples.
40. Hasani et al. (2012) the youngest and the oldest were 32 and 62 years old, the moderately satisfied rate in this study was 68% and the emotional intelligence score was 337. Overall, emotional intelligence and marital satisfaction were not linked to the variables of gender and age. Of many aspects of marital satisfaction, interpersonal and empathy aspects were meaningfully related to the variable of gender, regarding the statistics. Also, of many aspects of emotional intelligence, the one for responsibility between men and women was only meaningfully different, regarding the statistics. Total score of emotional intelligence and marital satisfaction were not meaningfully linked to gender. Generally, all the variables of emotional intelligence and marital satisfaction had a statistical meaningful relationship. 37% of marital satisfaction is predictable by emotional intelligence. Regarding the high relationship between emotional intelligence and marital satisfaction, it is greatly recommended that the related educational organizations of the country pay more attention to teach necessary skills to increase emotional intelligence so that matrimony is improved and family foundation is stronger.
41. Ayalon, Shiovitz-Ezra and Palgi (2013) study evaluated the associations between loneliness and subjective appraisals of marital relationship as well as reciprocal associations of loneliness in married men and women. The Health and Retirement Study is a national survey of older adults over the age of 50, residing in the US. Overall, 2723 couples completed this questionnaire. The model suggested that subjective appraisals of the relationship with spouse play a major role in one's sense of loneliness. In addition, loneliness in men and women shares reciprocal associations. The model explained 24% and 29% of the variability in loneliness reported by married men and women, respectively. Results indicate that capitalizing and enhancing one's social life might also be beneficial for his or her partner. Any intervention to alleviate loneliness in married couples has to take into consideration their perceived marital relationship as well as the reciprocal associations of loneliness in married men and women.
42. Landis et al. (2013) the present study examines the association between coping behavior and their relationship satisfaction in older spousal dyads. Examined N = 132 couples age ranged from 53–84 years (M age = 68 years) and found that their dyadic coping strategies – a prime indicator of functional adaptation to daily stress in marital context – were significantly linked to relationship satisfaction. Our findings suggest that the partner's subjective perception of their spouse's supportive behavior was more strongly linked to their relationship satisfaction than to their self-reported support. Furthermore, individual support perception was more important for marital satisfaction than coping congruency. Overall, the dyadic coping of older adults may serve as an effective tool to stabilize relationship satisfaction when facing the challenges of older age and long-term marriage.

## V. DISCUSSION

Based on the earlier researches on the mid-aged couples, discussed in this paper it is proved that there are several factors like family environment, work condition, social environment, financial status, marital relation etc. which affect married couples' adjustment and life satisfaction. There are several studies conducted on these correlates in different countries and societies. But still there is lacking of a dedicated study on factors affecting mid-aged couple's adjustment and satisfaction in Indian perspective which need to be addressed.

## REFERENCES

- [1] Anderson T. B., McCulloch B. J. (1993). Conjugal support: factor structure for older husbands and wives. *Journals of Gerontology*, 48(3), S133-42.
- [2] Ayalon L., [Shiovitz-Ezra S.](#), [Palgi Y.](#) (2013). Associations of loneliness in older married men and women. *Aging & Mental Health*, 17(1), 33-9.
- [3] Ider, E. S. (2010). *Age, Education Level, and Length of Courtship in Relation to Marital Satisfaction* (Master's thesis, Pacific University, 2010). Retrieved from <http://commons.pacificu.edu/spp/145>.
- [4] Brockmann H. (2009). Why are middle-aged people so depressed? evidence from West Germany. *German Socio-Economic Panel Study (SOEP)* 10117 Berlin, Germany.
- [5] Berg C.A., Schindler I, [Smith T.W.](#), [Skinner M.](#), [Beveridge R.M.](#) (2011). Perceptions of the cognitive compensation and interpersonal enjoyment functions of collaboration among middle-aged and older married couples. *Psychology and Aging*, 26(1), 167-173.
- [6] Bookwala J. (2005). The role of marital quality in physical health during the mature years. *Journal of Aging and Health*, 17(1), 85-104.
- [7] Crohan, S. E., [Antonucci](#), T. C., [Adelmann](#), P. K., [Coleman](#), L. M. (1989). Job characteristics and well-being at midlife ethnic and gender comparisons. *psychology of women quarterly*, 13, 223–235.
- [8] Dogra S. and Stathokostas L. (2012). Sedentary behavior and physical activity are independent predictors of successful aging in middle-aged and older adults. *Journal of Aging Research*, 2012, (2012), Article ID 190654, 8.
- [9] D'Zurilla T. J., Maydeu-Olivares A. and Kant G. L. (1998). Age and gender differences in social problem-solving ability. *Personality and Individual Differences*, 25(2), 241–252.
- [10] DT. J., Maydeu-Olivares A. and Kant G. L. (1998). Age and gender differences in social problem-solving ability. *Personality and Individual Differences*, 25(2), 241–252.

- [11] Fatimah P. L. R. (2012). Improvement on marital satisfaction by using quality approach. *Journal of social sciences and humanities*, 7(1), 133-148.
- [12] [Fiori K.L.](#), [Denckla C.A.](#) (2012). Social Support and Mental Health in Middle-Aged Men and Women A Multidimensional Approach. *Journal of Aging and Health*, 24(3), 407-438.
- [13] Goel S., Narang D. K. (2012). Gender differences in marital adjustment, mental health and frustration reactions during middle age. *IOSR Journal of Humanities and Social Science*, 1(3), 42-49.
- [14] [Henry N. J.](#), [Berg C. A.](#), [Smith T. W.](#), [Florsheim P.](#) (2007). Positive and negative characteristics of marital interaction and their association with marital satisfaction in middle-aged and older couples. *Psychology and Aging*, 22(3), 428-441.
- [15] [Huber C.H.](#), [Navarro R.L.](#), [Womble M.W.](#), [Mumme F.L.](#) (2010). Family Resilience and Midlife Marital Satisfaction. *Sage journals*, 19, 63-72.
- [16] Hansen T., Slagsvold B., Moum T. (2009). Childlessness and psychological well-being in midlife and old age: an examination of parental status effects across a range of outcomes. *Social Indicators Research*, 94(2), 343-362.
- [17] Hasani P. A. M., Mokhtaree M. R., Sayadi A. R., Nazer M. and Mosavi S. A. (2012). Study of emotional intelligence and marital satisfaction in academic members of Rafsanjan University of Medical Sciences. *J Psychol Psychother*, 2(2), 106.
- [18] Heiman, J. R., Long, J. S., Smith, S. N., Fisher, W. A., Sand, M. S., & Rosen, R. C. (2011). Sexual satisfaction and relationship happiness in midlife and older couples in five countries. *Archives of Sexual Behavior*, 40(4), 741-753.
- [19] [Kashiwagi, K.](#), [Hirayama, J.](#) (2003). Marital norm, reality and satisfaction in middle-aged couples: why are wives less satisfied than husbands? *Shinrigaku Kenkyu. [Article in Japanese]*, 74(2), 122-30.
- [20] [Karahar T.F.](#) (2009). The effects of a couple communication program on the conflict resolution skills and active conflict tendencies of Turkish couples. *Journal of Sex & Marital Therapy*, 35(3), 220-9.
- [21] Kouros, C. D., & Cummings, E. M. (2011). Transactional relations between marital functioning and depressive symptoms. *American Journal of Orthopsychiatry*, 81(1), 128-138.
- [22] [Lavalekar A.](#) (2007). Gender-Wise Comparison on Emotional Intelligence and Marital Satisfaction. *Gender and Behaviour*, 5(2), 1388-1405.
- [23] Libman and Eva (1989). Sociocultural and cognitive factors in aging and sexual expression: conceptual and research issues. *Canadian Psychology/Psychologie canadienne*, 30(3), 560-567.
- [24] [Lee J. E.](#), [Zarit S. H.](#), [Rovine M. J.](#), [Birditt K. S.](#), [Fingerman K. L.](#) (2012). Middle-aged couples' exchanges of support with aging parents: patterns and association with marital satisfaction. *Gerontology*, 58(1), 88-96.
- [25] Landis M., Peter-Wight M., Martin M., and Bodenmann G. (2013). Dyadic coping and marital satisfaction of older spouses in long-term marriage. *GeroPsych*, 26(1), 39-47.
- [26] Moosavi S.F. (2012). The comparison of family functioning, marital adjustment and intimacy in middle aged and young spouses. *International Research Journal of Applied and Basic Sciences*, 3(10), 2015-2021.
- [27] Myers, J. E., & Madathil, J. (2005). Marriage satisfaction and wellness in India and the United States: a preliminary comparison of arranged marriages and marriages of choice. *Journal of Counseling & Development*, 83(2), 183-190.
- [28] Pinto M. D. C. & Neto F. (2012). Satisfaction with sex life among middle-aged adults. *International Journal of Developmental and Educational Psychology*, 4(1), 463-470.
- [29] Pasupathi, M., Carstensen, L. L., Levenson, R. W., & Gottman, J. M. (1999). Responsive listening in long- married couples: a psycholinguistic perspective. *Journal of Nonverbal Behavior*, 23( 2), 173-193.
- [30] Rahmani A., Khoei E. M., Gholi L. A. (2009). Sexual Satisfaction and its Relation to Marital Happiness in Iranians. *Iranian Journal of Public Health*, 38(4), 77-82.
- [31] [Shek D. T. L.](#) (1999). Marital quality and health of Chinese couples: a longitudinal study. *Journal of Gender, Culture and Health*, 4(2), 83-96.
- [32] Skowron, Elizabeth A. (2000). The role of differentiation of self in marital adjustment. *Journal of Counseling Psychology*, 47(2), 229-237.
- [33] [Shiota M. N.](#), [Levenson R. W.](#) (2007). Birds of a feather don't always fly farthest: similarity in big five personality predicts more negative marital satisfaction trajectories in long-term marriages. *Psychology and Aging*, 22(4), 666-675.
- [34] Seider, Herschel B. (2011). Discrete emotion sequences and marital satisfaction in middle-aged and older couples. (dissertation [University of California, Berkeley](#), 2011) Retrieved from <http://gradworks.umi.com/34/99/3499356.html>
- [35] Schmitt, M., Kliegel, M., & Shapiro, A. (2007). Marital interaction in middle and old age: a predictor of marital satisfaction? *International Journal of Aging & Human Development*, 65(4), 283-300.
- [36] Story, T. N., Berg, C. A., Smith, T. W., Beveridge, R., Henry, N. J., & Pearce, G. (2007). Age, marital satisfaction, and optimism as predictors of positive sentiment override in middle-aged and older married couples. *Journal Article psychology and aging*, 22(4), 719-727.
- [37] [Seider B. H.](#), [Hirschberger G.](#), [Nelson K. L.](#), [Levenson R. W.](#) (2009). We can work it out: age differences in relational pronouns, physiology, and behavior in marital conflict. *Psychology and Aging*, 24(3), 604-13.
- [38] [Tianvuan L.](#) & [Fung H. H.](#) (2012). [Partner discrepancies and age differences in marital quality: distinguishing the ideal, expected, and perceived partner.](#) *The Journals of Gerontology Series B Psychological Sciences and Social Sciences*, 67(4), 417-22.
- [39] [Windsor, T. D.](#), [Butterworth, P.](#) (2010). [Supportive, aversive, ambivalent, and indifferent partner evaluations in midlife and young-old adulthood.](#) *J Gerontol B Psychol Sci Soc Sci*, 65(3), 287-95.
- [40] White S. D. & Myers J. E. (2006). Women at midlife: an exploration of chronological age, subjective age, wellness, and life satisfaction. *Adultspan Journal*. 5(2), 67-80.
- [41] Yeh, H. C., Lorenz, F. O., Wickrama, K. A., Conger, R. D., Elder, G. H. Jr. (2006). Relationships among sexual satisfaction, marital quality, and marital instability at midlife. *Journal of family psychology*, 20(2), 339-343.
- [42] Zainah, A. Z., Nasir, R., Hashim R.S. & Yusof N.M. (2012). Effects of demographic variables on marital satisfaction. *Asian Social Science*, 8(9).

#### AUTHORS

**First Author** – Shweta Nema, Research Scholar Department of Home Science Banasthali University, [snmprj@gmail.com](mailto:snmprj@gmail.com)

**Second Author** – Prof. Indu Bansal, qualifications Dean Faculty of Home Science Banasthali University, [indubnsl@yahoo.com](mailto:indubnsl@yahoo.com)

**Correspondence Author** – Shweta Nema, Research Scholar Department of Home Science Banasthali University, [snmprj@gmail.com](mailto:snmprj@gmail.com)



# Impact of Corporate Social Responsibilities in Modern Business Environment

Latika Verma

MBA in HR, Research Scholar, Department Of Management, Commerce and Economics, Shri Ramswaroop Memorial University, Lucknow

**Abstract-** Corporate social responsibility has much broader implications for the nation as a whole. It reduces dependency on the government for social change. Most governmental programmers quickly become embroiled in political manipulation, corruption, communal overtones, and bitter infighting. There is a need for evaluation and proper strategy for public-private partnership with well-defined controls and processes for the best use of resources for social change. Social reforms driven by the community will bring people together, turn the attention of the masses to tasks that benefit society, and reinforce peace and harmony. Social responsibility should not be limited to large successful corporations; there should be greater participation from most small, medium, and large businesses. The goodwill firms can generate from acts of social responsibility may, in fact, be worth far more to the businesses than the amounts they give. Corporations collectively can make India a better place for every citizen. Corporate social responsibility is about tradition and culture. It is necessary to create jobs and economic activity in rural communities to uplift the masses. Unless wealthy corporations and individuals spend on goods and services that touch the masses, economic prosperity for most of the population will remain a dream. Firms can institutionalize voluntarism among employees through appropriate incentives and recognition. Internal performance evaluation of employees could recognize community work. Community work can take many forms: teaching in government schools, supporting NGOs financially, empowering women, cleaning parks, planting trees, volunteering in orphanages, protecting the abused. Even if companies do not reward community activities, at least, the idea that the company cares will have a positive impact. Inculcating corporate social responsibility is also about training young minds and helping future generations organize themselves for greater good. Social responsibility needs to be deeply ingrained from childhood. Social responsibility is about leadership, respect for fellow human being and balances.

**Index Terms-** corporate social responsibility, public private partnership, voluntarism.

## I. INTRODUCTION

AS per United Nations and the European Commission, Corporate Social Responsibility (CSR) leads to triple bottom-line: profits, protection of environment and fight for social justice. It is expected that Civil society, activist groups, Government and corporate sectors should work together to create

appropriate means and avenues for the marginalized and bring them to the mainstream. The success of CSR lies in practicing it as a core part of a company's development strategy. It is important for the corporate sector to identify, promote and implement successful policies and practices that achieve triple bottom-line results.

There are many instances where corporate have played a dominant role in addressing issues of education, health, environment and livelihoods through their corporate social responsibility interventions across the country.

## Corporate Social Responsibility

The well accepted definition of CSR is not a common term; MNC's prefers sustainable development or sustainable business while several Indian companies talk about responsible business or Triple P (People, Planet, and Profit). It is important to note that Indian companies and stakeholders give a broader definition of CSR than MNC and stakeholders. According to the Indian Corporate: "Sustainable development implies optimizing financial position while not depleting social and environmental aspects and CSR implies supporting issues related to children, women and environment". These corporate refer in its definition of CSR to community development. In the context of Western community, development is often seen as charity. In the Indian context it is seen as a large responsibility of a corporate, not only by stakeholders but also by the local Indian management. The background of this is that stakeholders see the large western companies as capitalist islands in a developing country. This position gives them a certain responsibility towards the community. Most of the MNC's leave room to their Indian daughter company to develop initiatives in this field; sometimes they have a special fund.

Today, CSR in India has gone beyond merely charity and donations, and is approached in a more organized fashion. It has become an integral part of the corporate strategy. Companies have CSR teams that devise specific policies, strategies and goals for their CSR programs and set aside budgets to support them. These programs, in many cases, are based on a clearly defined social philosophy or are closely aligned with the companies' business expertise.

## Reduced burden of government: a result of Corporate Social Responsibility

Habitat for Humanity is a non-profit organisation of volunteers engaged in building affordable housing for the needy. This paper epitomizes corporate social responsibility, even when the firm's main objective is to increase shareholder value. The

Pariveda executives are great role models for the new recruits. This corporate activism is sustainable, acceptable, and valuable as a change agent, particularly in the context of India.

Corporate social responsibility has much broader implications for the nation as a whole. It reduces dependency on the government for social change. Most governmental programmes quickly become embroiled in political manipulation, corruption, communal overtones, and bitter infighting. There is a need for public-private partnership with well-defined controls and processes for the best use of resources for social change. Social reforms driven by the community will bring people together, turn the attention of the masses to tasks that benefit society, and reinforce peace and harmony.

### **Creating Social and Economic Value through Responsible Business**

- Calculating benefits and costs to make the business case;
- Identifying and managing positive as well as negative impacts;
- Integrating CSR best practices into key business areas;
- Recognising outstanding efforts towards this end.

However, the challenges in India are enormous. Social responsibility should not be limited to large successful corporations; there should be greater participation from most small, medium, and large businesses. The goodwill firms can generate from acts of social responsibility may, in fact, be worth far more to the businesses than the amounts they give. Corporations collectively can make India a better place for every citizen.

Corporate social responsibility is about tradition and culture. Firms can institutionalize voluntarism among employees through appropriate incentives and recognition. Internal performance evaluation of employees could recognize community work. Community work can take many forms: teaching in government schools, supporting NGOs financially, empowering women, cleaning parks, planting trees, volunteering in orphanages, protecting the abused. Many corporations in the U.S. allow employees to write about their community service as part of their annual evaluation report. Even if companies do not reward community activities, at least, the idea that the company cares will have a positive impact.

### **Responsible business cooperation and Civil Society as Good Neighbours**

- Recognizing the links between the welfare of society and that of the company;
- Proactively examining opportunities designed to benefit the organization and the community in terms of the environment, diversity, human rights, social impact, and the economy;
- Facilitating relationship building between NGOs and Corporations as co-actors of development.

### **Public-Private Partnerships make an effective development programs**

The HIV/AIDS public-private partnerships established by USAID in developing countries help not only those affected by

the disease, but also the partners themselves by offering a variety of benefits.

### **Business**

Partnerships fulfill a crucial role in corporate responsibility for a business. They drive the growth of that entity, while increasing the chances of sustainability for the partnership. Many businesses indigenous to host countries have experienced financial setbacks as a result of the AIDS epidemic. Many confront such problems as employee absenteeism, declines in skilled workers, high rates of turnover, and increased training and health care costs. Moreover, HIV/AIDS reduces the demand for consumer goods. When people are ill and unable to work, they do not have resources to spend on consumer goods and services. By entering into partnership with USAID, a business can reduce costs, better protect the health of its employees, or improve conditions for its customers. By partnering with USAID, larger multinational corporations can expand their reach into local host country communities, building relationships with families and networks of local leaders, and, in some cases, offering business opportunities to vulnerable populations.

### **Nongovernmental organization**

In developing countries, many NGOs serve children and adults who have a complex set of needs resulting from HIV infection and other factors, such as poverty, malnutrition, and insufficient sanitation. By participating in a USAID public-private partnership, an NGO is able to avail itself of resources it otherwise might not have and use those resources to strengthen and expand its portfolio of services.

### **Host Government**

Host country governments in developing nations understand the challenges of keeping their citizens healthy, productive, and secure. In many cases, governments have not fully established national systems or the institutional capacity to implement HIV/AIDS programs of sufficient quality and scope. Through public-private partnerships, host governments gain access to varied networks, resources, and knowledge, which they can use to inform and fortify the systems and institutions they have in place. They also can help ensure that joint initiatives are appropriate to the needs and culture of the country. In these ways, governments can participate in the development of services that are effective, enduring, and ultimately owned by the country. Another advantage to HIV/AIDS public-private partnerships is that their effects frequently spill over to influence broader efforts in sustainable development. Public-private partnerships also play a pivotal role in country ownership by creating a bridge between the public and private sectors.

### **Today's leader for corporate social responsibility**

Corporate social responsibility has much broader implications for the nation as a whole. It reduces dependency on the government for social change. Most governmental programmes quickly become embroiled in political manipulation, corruption, communal overtones, and bitter infighting. There is a need for public-private partnership with well-defined controls and processes for the best use of resources for social change. Social reforms driven by the community will bring people

together, turn the attention of the masses to tasks that benefit society, and reinforce peace and harmony.

In recent times, a number of foundations set up by leading Indian firms, including Infosys, Wipro, Tatas, TVS, and Dr. Reddy's Laboratory, have taken a keen interest in corporate activism to improve healthcare, education, and living conditions, and reduce poverty. These foundations support numerous government primary schools and have developed processes and methodologies for effective change. They support hundreds of non-governmental organisations and have built orphanages, hospitals, and schools.

### **CSR Strategies Focusing on Protection rather than Competitive Advantage**

A CSR strategy that is focused on avoiding regulatory liability and maintaining a license to operate in the current business will neither lead to current competitive advantage nor an imagination of future business models. Managing regulations, risk and legitimacy (license to operate) is also reflected in the main capabilities emphasized by the respondents: ethical behaviour, social accountability and stakeholder engagement. In order to leverage its CSR/sustainability strategy for competitive advantage, an organization needs the advanced capabilities of organizational learning and sustainable innovation. These two capabilities are critical for building sustainable business models that will lead to future sustained competitive advantage.

CSR has come a long way in India. From responsive activities to sustainable initiatives, corporate have clearly exhibited their ability to make a significant difference in the society and improve the overall quality of life. In the current social situation in India, it is difficult for one single entity to bring about change, as the scale is enormous. Corporate have the expertise, strategic thinking, manpower and money to facilitate extensive social change. Effective partnerships between corporate, NGOs and the government will place India's social development on a faster track.

In an article on Trust and Corporate Social responsibility: Lessons from India, authors mentioned Spirituality and Corporate Social Responsibility have had a deep-rooted connection in India.

A phenomenon that has preceded the coining of the term 'CSR', the link between the 'karma' as espoused by sacred Indian texts and initiatives anchoring corporate as responsible citizens has been amply evident in India since the early days.

### **Issues & Challenges**

Many companies think that corporate social responsibility is a peripheral issue for their business and customer satisfaction more important for them. They imagine that customer satisfaction is now only about price and service, but they fail to point out on important changes that are taking place worldwide that could blow the business out of the water. The change is named as social responsibility which is an opportunity for the business.

Some of the drivers pushing business towards CSR include:

### **The Shrinking Role of Government**

In the past, governments have relied on legislation and regulation to deliver social and environmental objectives in the

business sector. Shrinking government resources, coupled with a distrust of regulations, has led to the exploration of voluntary and non-regulatory initiatives instead.

### **Demands for Greater Disclosure**

There is a growing demand for corporate disclosure from stakeholders, including customers, suppliers, employees, communities, investors, and activist organizations.

### **Increased Customer Interest**

There is evidence that the ethical conduct of companies exerts a growing influence on the purchasing decisions of customers. In a recent survey by Environics International, more than one in five consumers reported having either rewarded or punished companies based on their perceived social performance.

### **Growing Investor Pressure**

Investors are changing the way they assess companies' performance, and are making decisions based on criteria that include ethical concerns. The Social Investment Forum reports that in the US in 1999, there was more than \$2 trillion worth of assets invested in portfolios that used screens linked to the environment and social responsibility. A separate survey by Environics International revealed that more than a quarter of share-owning Americans took into account ethical considerations when buying and selling stocks. (More on socially responsible investment can be found in the 'Banking and investment' section of the site.)

### **Competitive Labour Markets**

Employees are increasingly looking beyond pay checks and benefits, and seeking out employers whose philosophies and operating practices match their own principles. In order to hire and retain skilled employees, companies are being forced to improve working conditions.

### **Supplier Relations**

As stakeholders are becoming increasingly interested in business affairs, many companies are taking steps to ensure that their partners conduct themselves in a socially responsible manner. Some are introducing codes of conduct for their suppliers, to ensure that other companies' policies or practices do not tarnish their reputation.

The challenges for the Corporate Social responsibility are as follows:

### **Lack of Community Participation in CSR Activities**

There is a lack of interest of the local community in participating and contributing to CSR activities of companies. This is largely attributable to the fact that there exists little or no knowledge about CSR within the local communities as no serious efforts have been made to spread awareness about CSR and instill confidence in the local communities about such initiatives. The situation is further aggravated by a lack of communication between the company and the community at the grassroots.

### **Need to Build Local Capacities**

There is a need for capacity building of the local non-governmental organizations as there is serious dearth of trained and efficient organizations that can effectively contribute to the ongoing CSR activities initiated by companies. This seriously compromises scaling up of CSR initiatives and subsequently limits the scope of such activities.

### **Issues of Transparency**

Lack of transparency is one of the key issues brought forth by the survey. There is an expression by the companies that there exists lack of transparency on the part of the local implementing agencies as they do not make adequate efforts to disclose information on their programs, audit issues, impact assessment and utilization of funds. This reported lack of transparency negatively impacts the process of trust building between companies and local communities, which is a key to the success of any CSR initiative at the local level.

### **Non-availability of Well Organized Non-governmental Organizations**

It is also reported that there is non-availability of well organized nongovernmental organizations in remote and rural areas that can assess and identify real needs of the community and work along with companies to ensure successful implementation of CSR activities. This also builds the case for investing in local communities by way of building their capacities to undertake development projects at local levels.

### **Visibility Factor**

The role of media in highlighting good cases of successful CSR initiatives is welcomed as it spreads good stories and sensitizes the local population about various ongoing CSR initiatives of companies. This apparent influence of gaining visibility and branding exercise often leads many nongovernmental organizations to involve themselves in event-based programs; in the process, they often miss out on meaningful grassroots interventions.

### **Narrow Perception towards CSR Initiatives**

Non-governmental organizations and Government agencies usually possess a narrow outlook towards the CSR initiatives of companies, often defining CSR initiatives more donor-driven than local in approach. As a result, they find it hard to decide whether they should participate in such activities at all in medium and long run.

### **Non-availability of Clear CSR Guidelines**

There are no clear cut statutory guidelines or policy directives to give a definitive direction to CSR initiatives of companies. It is found that the scale of CSR initiatives of companies should depend upon their business size and profile. In other words, the bigger the company, the bigger is its CSR program.

### **Lack of Consensus on Implementing CSR Issues**

There is a lack of consensus amongst local agencies regarding CSR projects. This lack of consensus often results in duplication of activities by corporate houses in areas of their intervention. This results in a competitive spirit between local

implementing agencies rather than building collaborative approaches on issues. This factor limits company's abilities to undertake impact assessment of their initiatives from time to time.

## **II. CONCLUSION**

The concept of corporate social responsibility is now firmly rooted on the global business agenda. But in order to move from theory to concrete action, many obstacles need to be overcome. A key challenge facing business is the need for more reliable indicators of progress in the field of CSR, along with the dissemination of CSR strategies. Transparency and dialogue can help to make a business appear more trustworthy, and push up the standards of other organizations at the same time.

## **REFERENCES**

- [1] Redington Ian (2005). Making CSR Happen: The Contribution of People Management, Chartered Institute of Personnel and Development, retrieved on April 15, 2008 from [www.bitc.org.uk/document.rm?id=5103](http://www.bitc.org.uk/document.rm?id=5103).
- [2] Rupp Deborah E, GanapathiJyoti, Aguilera Ruth V, Williams Cynthia A (2006). Employee Reactions to Corporate Social Responsibility: An Organizational Justice Framework, *Journal of Organizational Behavior*, 27: 537-43.
- [3] Sirota Survey Intelligence (2007) quoted from CSR boosts employee engagement, Social responsibility boosts employee engagement 09 May, <http://www.management-issues.com/2007/5/9/research/social-responsibility-boosts-employee-engagement.asp>
- [4] Murray Norm E (2008). Corporate Social Responsibility is the Number One Criteria for Job Hunters Today, retrieved on March 30, 2008 from <http://normmurray.org/2008/02/18/corporate-social-responsibility-is-the-number-one-criteria-for-job-hunters-today/>
- [5] MeesAdine& Bonham Jamie (2004). Corporate Social Responsibility Belongs with HR, *Canadian HR Reporter*, Vol. 17(7): 11
- [6] Krishnnan K, Sandeep&BalachandranRakesh (2004). Corporate Social Responsibility as a determinant of Market Success: An Exploratory Analysis with Special Reference to MNCs in Emerging Markets, paper presented at IIM K- NASMEI International Conference.
- [7] BeradNilesh R. (2011). Corporate Social Responsibility – Issues and Challenges in India paper presented on International Conference on Technology and Business Management

## **AUTHORS**

**First Author** – Latika Verma, MBA in HR, Research Scholar, Department Of Management, Commerce And Economics, Shri Ramswaroop Memorial University, Lucknow, E-mail address: [latikaverma14@gmail.com](mailto:latikaverma14@gmail.com)

# India's Prime Minister Narendra Modi Visit to Nepal: Renewing Relations.

Tariq Rashid Wani

\*Research Scholar School of studies in Political science Vikram University Ujjain, M.P-India

**Abstract-** This paper attempts to highlight the new beginning of Indo-Nepal relationships which reached its highest peaks during India's Prime Minister Narendra Modi's Visit to Nepal. The paper also attempts to explain the political and economic perspective of Indo-Nepal relations and Mr. Narendra Modi also lays stress upon 4Cs co-operation, connectivity, culture and constitution which may improve bi-lateral ties with Nepal.

**Index Terms-** Indo-Nepal Relation, hydropower, constitution

## I. INTRODUCTION

As close neighbours, India and Nepal share a unique relationship of Friendship and cooperation characterized by open borders and deep-rooted people-to-people contacts of kinship and culture. There has been a long tradition of free movement of people across the borders. Nepal has an area of 147,181 Sq. Kms. and a population of 29 million. It shares a border of over 1850 Kms in the east, south and west with five Indian States - Sikkim, West Bengal, Bihar, Uttar Pradesh and Uttarakhand - and in the north with the Tibet Autonomous Region of the People's Republic of China.

Prime Minister Narendra Modi's two day visit to Nepal, on 3-4 August 2014, marked a new beginning in Indo-Nepal relations. Prime Minister Modi extended support to Nepalese constitution makers and political leaders and "conveyed best wishes of the government and people of India to the Nepalese leadership and people for their commitment to promulgate the new constitution by early next year." Nepal is facing constitutional crisis since the Constituent Assembly was dissolved without drafting a new constitution in 2012. Prime Minister Modi hoped that the Constituent Assembly would draft a constitution to support federal and democratic political structure and promote equality in the country. Assuring the political leaders of Nepal, Prime Minister said "we are ready to extend all necessary helps to bring the constitution on time". His address to the Constituent Assembly of Nepal was appreciated by many Nepalese leaders across the "political spectrum". Interestingly, Pushpa Kumar Dahal or Prachanda, who has been a strong critic of India, praised Prime Minister Modi for touching, inspiring and encouraging speech. Prachanda, chairman of the United Communist Party of Nepal-Maoist (UCPN-M), after the meeting with Prime Minister Modi, expressed confidence that "a new chapter has begun in Indo Nepal relations".

## II. OBJECTIVE

- 1 To study Indo-Nepal relation in the context of Modi's visit.
- 2 To explain Political perspective and Economic and cultural perspective in context of Modi's visit.

## III. RESEARCH METHODOLOGY

For the purpose of the study, both published and unpublished secondary data has been utilized. The data is collected from various magazines, Newspapers, such as the Hindu, Hindustan Times, Times of India

## IV. POLITICAL PROSPECTIVE

India's Prime Minister Narendra Modi has concluded an important visit to Nepal where he tapped all the right nodes of the relations - political, economic and cultural. Modi focussing on 4 C-S co-operation, connectivity, culture and constitution, which may enhance bi-lateral ties with Nepal and is the first prime minister who visited Nepal after 17 years.

Nepal has been unusually united in its embrace of Mr. Modi, the first Indian prime minister in 17 years to make a state visit here. Nepali and Indian flags fluttered throughout a warren of muddy streets in the capital, Katmandu, and large banners were hung across major intersections welcoming him. "Long live Nepal-India friendship," they declared.

Mr. Modi arrived in Nepal a landslide swept down a valley northeast of Katmandu, leaving 150 people missing and at least 17 dead. "We have no hope of finding anyone alive there," said Yadav Prasad Koirala of Nepal's home ministry. Some 8,000 people who had been evacuated from the area after the landslide Saturday have begun to return to their homes, he added.

Modi in a high rhetoric and colourful phrases, he referred that India and Nepal relationship as "older as Himalayas and the Ganga, he also stress on constitutional framework of Nepal. He said to the Nepalese leadership president Ram Baran Yadav and prime minister Sushil Koirala in his quota Narendra Modi said that "you should not think about the party but the country Nepal need a constitution at the earliest".

Modi also assured Nepal that India did not want interfere in its internal affairs "Nepal is a truly sovereign nation we have always believed that it is not our job to interfere in what you do but to support you in the path you decide to take".

He said while addressing the constituent assembly the first time a guest has been invited to address a joint session of the

constituent assembly and parliament in Kathmandu. He gave powerful 45 minutes speech to Nepal law makers. I am eager to take the relation between India & Nepal to new height during my tenure as prime minister.

The Indian prime minister assured the Nepalese prime minister that the on-going peace process in Nepal was entirely a Nepalese matter should be concluded as Nepal's requirement. Modi also met Nepalese soldier's and he walked around him and greeting them. "We have had elation for many years because of political instability and political interference said Rajesh war Thapa On f the people cheering the PM convey "We hope Mr. Modi will change that"

#### V. ECONOMIC AND CULTURAL PROSPECTIVE

India's Prime Minister Modi plans to provide one billion dollars in loans to help build infrastructure in Nepal and tries to regain ground as a power in south Asia. He assured that the work on Pancheswar multipurpose would begin in a year in the presence of two prime ministers the officials signed three agreements Ice Memorandum of the understanding (MOU)-tourism development in Nepal, Goitre, control program in Nepal, and co-operation between the state controlled televisions channels-doorarshan and Nepal television (NTP), They also exchanged reference for on Pancheswar development authority. Modi added that my visit is focussed on development and a new beginning between two countries.

During his two-day visit, Mr. Modi has emphasized the cultural and religious ties between India and Nepal, which are both Hindu-majority nations. A leader with Hindu nationalist roots, Mr. Modi offered prayers at an important Hindu temple in Katmandu on Monday.

Mr. Modi's visit has inspired unusual consensus here that Nepal set aside decades of mistrust and accept Indian offers to help develop Nepal's hydropower and tourism potentials. Such optimism has flowered before here only to be crushed by Indian indifference or Nepal mistrust, but there is real hope that this time will be different. Mr. Modi's campaign messages of economic development and good governance resonated strongly in Nepal, which has been deprived of both for decades. "This is a once-in-a-generation opportunity to begin fresh and build a level of trust that needs to be developed to define relations for the next 50 years," said Sridhar k. Khatri, former executive director of the south Asia Center for policy studies in Katmandu.

A last-minute dispute over the wording of a major hydropower development agreement meant that the two sides signed only minor agreements on Sunday. But there is considerable hope that the power deal will materialize.

Before his speech, some analysts worried that Mr. Modi would urge Nepal to adopt a constitutional provision declaring the country a Hindu state, as royalist factions have advocated. An avowed Hindu nationalist, Mr. Modi is scheduled to visit the Pashupatinath temple, one of Hinduism's holiest places, on Monday, an arrangement made in part to coincide with a religiously auspicious day.

"To avoid any misperception, Modi must clearly support the current draft constitution's identification of Nepal as a 'federal, secular democratic republic, said by Raja Mohan, an Indian foreign affairs analyst.

In his speech, Mr. Modi described Nepal as a "federal democratic republic," dropping the "secular," long a fraught word in Indian politics as well. But he did not call for explicit Hindu identification and said Nepal was "the birth place of Lord Buddha."

All in all, Mr. Modi got high marks. "Modi is giving us a good moment," Bhekh b. Thapa, a former Nepal minister of foreign affairs and finance, said in an interview. "Whether it will yield results, time will tell."

The new Indian administration hopes to use the visit to make progress on a power-trading pact to help India harness Nepal's abundant hydroelectric-power potential, by which Mr. Modi said that he can solve India's power shortage.

"You decide what needs to be done, India will stand by you," he said.

#### VI. CONCLUSION

The visit opened a fresh chapter in Indo- Nepal relations. By giving new idea of "federal and democratic republic", Prime Minister Modi dispelled fears in Nepal that the new government in India might work for the restoration of monarchy. His momentous speech in Nepal's Parliament won the hearts and minds of Nepalese. Both countries endorsed new developmental projects, showed their willingness to improve the peace and security at border, promised to improve border infrastructure, and expressed concern over the slow pace of implementation of many projects. In fact, a momentum has already been generated in Indo- Nepal relations and it must be continued with better follow up and implementations

#### REFERENCES

- [1] Dr. Amity Kumar, Research Fellow at Indian Council of World Affairs, New Delhi.
- [2] [Http.www.Hindustantimes.com](http://www.Hindustantimes.com) 03 to 06 August 2014
- [3] [Http. www .The Hindu.com](http://www.TheHindu.com) 03 to 06 August 2014
- [4] [Http.www .times of india.com](http://www.timesofindia.com) 03 to 06 August 2014
- [5] The Hindu, A new beginning with Nepal 23, July 2014, IST 00; 45
- [6] The Hindu, Modi concludes historical visit to Nepal, 4 August 2014
- [7] The Hindu, Modi offers loans to Nepal, "tries to boost India's regional status, August 4, 2014
- [8] Hindustan times, After Modi's visit, will India China completion over Nepal intensify, 13 July 2014
- [9] [www.indianEmbassy.com](http://www.indianEmbassy.com)

#### AUTHORS

**First Author** – Tariq Rashid Wani, Research Scholar School of studies in Political science Vikram University Ujjain, M.P-India, Email: tariqwani995@gmail.com



# Actual Transaction Behavior of Internet Banking Services among Iraqis Customers Using PLS Approach

<sup>1</sup>Alaa Ahmed Chyad Alkafagi, <sup>2</sup>Ruslan Bin Romli, <sup>3</sup>Ahmad Yusni Bin Bahaudin, <sup>4</sup>Jamal Mohammed Alekam, <sup>5</sup>Anas Abdelsattar Mohammad Salameh

<sup>1,2,3,4,5</sup>School of Technology Management & Logistics, Universiti Utara Malaysia, Kedah, 06010, Malaysia  
<sup>1</sup>Republic of Iraq, Ministry of Industry and Minerals, Al-furat Company for Chemical Industries

**Abstract-** The main purpose of this research is to identify the factors that encourage adopters to take up the Internet banking services in Iraq. This paper is concerned with an empirical investigation of individual factors technology that could predict successful IBSA in Iraq through the applications of planned behavior theory (TPB). This study uses sampling units in a questionnaire survey data of 535 Iraqis public university employees as customers of internet banking services who were using it already. This study applied partial least squares structural equation modeling (PLS-SEM) as the major analysis technique as well as SPSS, since PLS-SEM is a relatively new analytical technique in construction. The findings of this study suggests that attitude and perceived behavior control (PBC) have significant and positively influences IBSA, while Subjective norm (SN) is unsupported. Related to individual factors technology (IFT), in this study there are 5 constructs all of them (technology and Internet literacy, resistance to change, risk of technology, and anxiety of technology, and trust of technology) supported with researcher expectation.

**Index Terms-** TPB, Actual Transaction, Internet Banking, IFT, Republic of Iraq, PLS.

## I. INTRODUCTION

The Internet, and its associated technologies, are the keys to the survival and growth of businesses in today's competitive environment. Web technologies have been instrumental in helping many banks to establish their presence on the Internet, so that they can provide customers with many facilities to perform interactive banking transactions (Al-Somali et al., 2009). Technological developments have availed opportunities for the banks and other service providers alike, to develop and offer customers greater flexibility, and more services, as consumers today are demanding better facilities and services (Tan & Teo, 2000). According to Jalal, Marzooq, & Nabi (2011), Internet banking has been growing significantly, and has a direct impact on the way businesses are conducted.

Despite more and more banks began to provide Internet banking services to their customer, however, recent indicators show that the rate of internet banking service usage in Iraq is only 1% of total clients (Ipbl, 2012; KIB, 2012; Niqash, 2012; International Research & Exchanges Board, 2011; ITU, 2010). This evidence seems to imply that Internet Banking Services (IBS) in Iraq are still at very minimal levels. There is therefore the necessity to have more research to investigate factors

influencing the customers' behavior towards adopting Internet Banking in Iraq (Shendi, 2011; Mohsen, 2010).

However, Internet banking adoption by customers remains a complex, elusive, yet extremely vital phenomenon (Hoehle et al., 2012). Indeed, there is no doubt that internet banking services adoption (IBSA) represents the opportunities for developing nations to leap forward towards greater economic development and growth, where the creation of added value is driven by information, knowledge, and the adoption of ICTs.

Based on the review of past literature related to Internet banking, it shows that several studies focus on intention to use (Tan & Teo, 2000; Shih & Fang, 2004 & Hernandez & Mazzon, 2007) or focus comparison between adopters and non-adopters (Sathye, 1999; Suganthi et al., 2001; Gerrard and Gumingham, 2003; Akinci et al., 2004; Chan & Lu, 2004; Laforet & Li, 2005; Lee et al., 2003; Gerrard et al., 2006; Awamleh & Fernandez, 2006; Polasik & Winsniewski, 2009 & Foon & Fah, 2011), rather than investigating the Internet banking adopters (Hong et al., 2013). However, this study focuses on encourage adopters to take up the Internet banking services. This is because empirical research on this issue is very limited. Therefore, this study aims to fill up this research gap and provides an empirical evidence.

Hence, there should be more researches on the Internet banking adoption be conducted to explore and unearth the underlying contributory factors and to indirectly spur the interest in this area of research. The purpose of this research is to investigate the factors that influence adopters to continue adopt Internet banking.

Prior researches may not have identified all the issues involved in adoption and use and may be limited in other ways. Scholars face challenges researching this area due to fragmented findings and methods over three decades of study (Hoehle et al., 2012, P. 1). There is however a lack of published work which explains the factors supporting IBSA, from customers' perspectives in the context of developing countries in the Middle East in general, and in Arab countries, in particular, Iraq (Mahdi, 2011, p. 5534; Shendi, 2011, P.17; Al-Somali et al., 2009, P.13). IBSA, in previous studies, has shown mixed findings (Al-Majali, & Mat, 2011, p. 2; Ndubisi & Sinti, 2006, p. 16).

This scenario is not unique just for Iraq – in spite of the many benefits that both customers and banks obtain from Internet banking, acceptance of this technology is very varied in all parts of the world (Alnsour & Al-Hyari, 2011, p. 5).

## II. LITERATURE REVIEW

According to Ajzen (1991), TPB consists of actual behavior, behavioral intention, attitude, subjective norm, and PBC. TPB states that behavior is a function of salient beliefs related to that behavior, which are considered as the main determinants of a person's behavioral intentions and actual behavior. TPB postulates that attitude, subjective norm and PBC influence the behavioral intention to use a technology. These are defined as follows:

**Attitudinal beliefs:** influences attitude towards behavior, and is referred to as: "Behavioral belief is the subjective probability that the behavior will produce a given outcome".

**Normative beliefs:** normative beliefs, and the person's motivation to comply with different referents, determine the prevailing subjective norm. Normative beliefs are referred to as: "The perceived behavioral expectations of important influential referent individual or group".

**Control beliefs:** the perceived presence of factors which facilitate or hinder performance of behavior, contributing to PBC, in proportion to the factors present in a given situation. In the context of IS research, these beliefs are defined as: "A perceptions of internal and external constraints on behavior" (Taylor & Todd 1995. p. 149). Furthermore, PBC refers to "the degree to which a person has the skills, resources, and other prerequisites to perform or defend a given behavior" (Ajzen, 1991, p. 188) as shown in Figure 1.

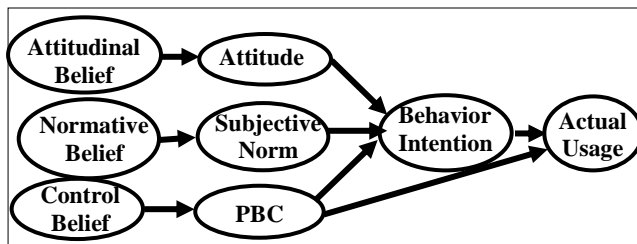


Figure 1: TPB (Ajzen, 1991)

TPB has been applied in various settings of technology acceptance. Furthermore it has been successfully applied in IBSA area in predicting the performance of IBSA. For e.g., in Korea, the study related to IBSA was conducted by Ok and Shon (2010), to find out the factors influencing IBSA. The TPB model has been extended by Shih & Fang (2004) to illustrate the factors affecting behavioral intention to adopt IBS. The finding revealed that although attitude is significantly toward intention, subjective norm and perceived behavior control are not. Beside that, Tan and Teo (2000) and Celik (2008) have used TPB in IBS area, Mathieson (1991) and Taylor & Todd (1995) have used TPB in information systems literature.

Ajzen and Fishbein (1980, p.82) defined Actual Behavior as: "The individual's observable response in a given situation with respect to a given target; behavior is a function of compatible intentions". In addition, IBSA is defined by Kim and Prabhakar (2000, P. 538) as: "The client's usage of multiple services represented in carrying out banking transactions over the Internet, including balance inquiry, account transfer, and many other services that are basically carried out online".

IBS is extremely beneficial to customers: customers can execute their bank transactions or contact their banks faster, at anytime and from anywhere, 24 hours a day. It does not require the physical interaction with the bank, and customers can avoid long queues and restrictive business hours, lower transaction costs, quick responses to complaints, more service variety and improved services quality (Mansumitchai & Chiu, 2012; Alnsour & Al-Hyari, 2011; Nasri, 2011; Al-Somali et al., 2009; Shi et al., 2008; Mattsson & Helmersson, 2005; Pikkarainen et al. 2004). Customers also do not have to be put on hold for telephone banking services; all these benefits make for easier banking (Karjaluo, Mattila & Pento, 2002).

The aim of this study to examine many individual factors of technology (internet technology literacy, resistance to technology, risk technology, anxiety about technology, and information on technology) in IBSA setting generally those could influence on the behavior of customers toward IBSA. This study, therefore, is using these factors to investigate the adoption of Internet banking in Iraq.

Iraqi citizens are unaware of the benefits that technology can bring, and even if they do, they do not have the skills to use the Internet technology and computer effectively (Shendi, 2011). Besides, there is limited empirical study on TPB in Middle East (Al-Majaly, 2011, p. 39), specifically in Arab countries like Iraq.

## III. RESEARCH MODEL

A theoretical framework is a representation of reality; it explains in greater detail those aspects (variables) of the real world the scientists consider to be relevant to the problem being investigated, and clarifies the significant relationship among them (Frankfort-Nachmias & Nachmias, 1996). The research framework proposed in this study is not exactly the same as the TPB model, the researcher have added direct relationships from attitude and subjective norms to IBSA, which is not in TPB original model.

Individuality or Personality refers to "the cognitive and affective structures maintained by individuals to facilitate their adjustments to the events, people and situations encountered in life" (Abushanab et al., 2010; Zmud, 1979). According to Venkatesh et al. (2003), the individual characteristics of the users a strong predictor of actual usage.

The internet technology literacy is, i.e. the previous technology experience with IBS. In other words, when the technology literacy increases among customers, then the rate of adoption of IBS will also increase. When consumers become more familiar with technologies, this will facilitate their appreciation of the added value in a technology. Karjaluo et al. (2002) revealed that previous technological experience, i.e., with the internet and attitudes towards computers, influence attitudes towards online banking and actual behavior. They noted that the lack of computer or internet access is one of the possible factors for delayed adoption of IBS. According to the result of the study that identify the factors which affect the decision of social media to make purchasing in Thailand, the chance of technology adoption will be increased if people with higher knowledge in technology are more likely to possess and understand the issues of a new technology, because the ability to understand and apply

from simple to complex technical knowledge is needed for adoption (Avirutha, 2012).

The second individual technology factor is user resistance to technology; it is the most critical factor that inhibits the adoption of technology. According to Dewan, Lorenzi, and Zheng (2004), user resistance is a factor that prevents technology adoption. Raymond (1985) explained the initiation, adoption, and implementation of technology are correlated with adopters' perception. Customers' resistance to change from traditional ways of banking to IBS has been researched in several studies (Sathye, 1999; Wallis, 1997; Alagheband, 2006; Al-Somali et al. 2009). According to the result of the study that identify the factors which affect the decision of social media to make purchasing in Thailand the user resistant to technology are significantly affected on the adoption of social media (Avirutha, 2012).

The third individual factor is perceived risk of technology. According to Cheah et al. (2011), perceived risk is the "uncertainty about the outcome of the use of the innovation of technology". Featherman and Pavlou (2003) defined perceived risk as the possible troubles faced when pursuing a desired result. In this regard, consumers tend to perceive higher risks in an online environment compared to a physical store situation (Yang et al., 2012; Chang & Tseng, 2011). About 75% of consumer's in China today worries about the transaction risks of using mobile payment services and a customer's this perception of risk reduces their intention to use a mobile payment service (Lu et al., 2011). A study conducted by Luo et al. (2010) found that user's perception of risk is a crucial driver to determine innovative technology acceptance. Based on these and other studies, it is expected that perceived risk will be a significant predictor of IBSA.

The fourth individual factor is perceived anxiety about technology. According to Compeau and Higgins (1995), anxiety refers to "person's emotional reaction when they use particular technology". The term 'anxiety' is most often used to describe an unpleasant emotional state or condition which is characterized by subjective feelings of tension, apprehension, and worry (Abushanab et al., 2010). A study was conducted by Ibrahim (2012) to examine the actual e-filing usage behavior in Malaysia. The results indicated that perceived anxiety is statistically significant as it outperformed the other factors in explaining the actual usage behavior of the e-filing system among Malaysian personal taxpayers. Abushanab et al. (2010) conducted a study to extend UTAUT by adding personality dimensions, toward behavioral intention to use IBS in Jordan. One of these factors was anxiety, and the finding of this study failed to explain a significant amount of variation of behavioral intention. This factor didn't use previously to measure customers' behavior toward IBS.

The last individual technology factor, is trust of technology. Trusting online activities is very important, and is a key to e-commerce development (Abushanab et al., 210; Suh & Han, 2002). According to Alsajjan & Dennis (2006), trust is even more vital for online banking compared to offline. Many researchers concur that trust is more important in online services in general, and in IBS, in particular. This is due to the fact that online banking transactions include sensitive information and users are concerned about access to critical files and information

transferred via the internet (Wang, 2011; Bradley & Stewart 2003; Mukherjee, Nath & Pal, 2003; Suh & Han 2002). Generally, across disciplines, there is agreement that trust only exists in an uncertain and risky environment. Mayer et al. (1995), as cited in Sonja and Ewald (2003), explained that trust is unnecessary if there is total certainty and no risk. Trust in e-service is very important because in a virtual environment, the degree of uncertainty of internet transactions is higher compared to traditional setting (Rotchanakitumnuai & Speece, 2003; Almajaly, 2011).

Based on the above discussion, the following hypotheses related to individual factors on IBSA are presented:

H1: Technology and Internet literacy have a positive influence on customers' adoption of Internet banking.

H2: Resistance to technology has negative influence on customers' adoption of Internet banking.

H3: Risk of technology has negative influence on customers' adoption of Internet banking.

H4: Anxiety of technology has negative influence on customers' adoption of Internet banking.

H5: Trust of internet banking has a positive influence on customers' adoption of Internet banking.

Related to the linkage between an individual's attitude and IBSA, there is very few studies have investigated this linkage in internet banking setting (AL-Majali & Mat, 2010b). However, most prior studies were conducted outside the Middle East countries, and not much was done in Iraq. Therefore, this study intends to fill this gap by examining customer's attitude toward IBSA in TPB theory in the Iraqi context. Given that, the researcher hypothesizes that:

H6: Attitude significantly and positively influences IBSA.

Despite the original TRA, TPB and DTPB models that discussed the relationship between subjective norm and behavioural intention, there are very few empirical studies which examined the relationship between subjective norm and IBSA (Shi et al., 2008; Dauda et al., 2007; Hernandez & Mazoon, 2007). Moreover, It has found mixed results, e.g. AL-Majali and Nik Mat (2010b) found this linkage is significant in Jordan, while Dauda et al. (2007) found that the relationship between subjective norm and IBSA is insignificantly among users in Malaysia. However, there is no study conducted in Iraq related to IBSA settings to examine this linkage. Based Given that, the researcher hypothesizes that:

H7: Subjective norm, significantly and positively influences on IBSA.

According to TPB model, PBC may directly influence the actual usage by intensifying the efforts to help with the achievement of goals (Taylor & Todd, 1995). Actually, few previous studies regarding the relationship between PBC and actual behavior in different areas (Gopi & Ramayah, 2007; Fusilier & Durlabhji, 2005; Pedersen & Nysveen, 2004; George, 2004). Beside, there are very few past studies that were done to examine the relationship between PBC and actual IBSA settings. Furthermore, there is inconsistency in the results revealed in previous studies about PBC and the actual behavior relationship; some previous studies found a significant relationship between PBC and actual behavior (Gopi & Ramayah, 2007; Fusilier & Durlabhji, 2005; George, 2004), while few studies found that there is an insignificant relationship (Pedersen & Nysveen,

2004). Based on this discussion, this study aims to test this linkage in IBSA. The following hypothesis is proposed:

H8: Perceived behavior controlling significantly and positively influences IBSA.

#### IV. METHODOLOGY

This study follows quantitative approach whereby the data is collected through self-administered questionnaire from respondents. Specifically, the population of this study is comprised of staff of public universities in Iraq; since they have bank accounts and are using the IBS (Al-majali & Mat, 2010b; Akinci et al., 2004). The researcher collected the data from the Middle, North, and South of Iraq (Mohesr, 2012). The researcher got back all of the questionnaires except a total of two hundred (200) questionnaires. Thus only six hundred (600) questionnaires were returned. After being returned, the 600 questionnaires were tested manually (Observation) and the researcher found that there are sixty-five (65) questionnaires that were incomplete, so these questionnaires were disregarded. Therefore, only five hundred and thirty five (535) questionnaires were useful for further steps of analysis that mean the response rate was 66% .

The survey measures 9 constructs, which are: Internet technology literacy, resistance to technology, risk of technology, anxiety about technology, trust of technology, attitude, subjective norm, PBC, and IBSA. All these variables are adopted or adapted from previous studies. The following is a summary of the instrument that will be used to measure all variables and its source with the coefficient alpha:

1. IBSA- by four items from Raman et al., (2008), for which the coefficient alpha produced by previous studies was is 0.81.
  2. Attitude- by five items from Nor and Pearson (2008), which had a reliability coefficient alpha of 0.94.
  3. Subjective norm - by five items from Nor and Pearson (2008), which has a coefficient alpha of 0.94.
  4. PBC- by four items from Shih and Fang (2004), which has a coefficient alpha of 0.86.
  5. Internet technology literacy - by five items from Nasri (2011). The coefficient alpha from his previous study for this measure is 0.868.
  6. Resistance to technology - by four items from Al-somail et al. (2009) and the coefficient alpha is 0.766.
  7. Perceived risk of technology - by four items from Grabner-Krauter & Faullant (2008) and Abushanab & Pearson (2010); four items were developed in an IBS area. The coefficient alphas produced by past studies (Grabner-Krauter & Faullant, 2008; Abushanab & Pearson, 2010) are 0.92 and 0.732, respectively.
  8. Anxiety about technology - by four items from past studies by Abushanab and Pearson (2010). The coefficient alpha from their previous study for this measure is 0.886.
  9. Trust - by six items adopted from Suh & Han (2002), which has a coefficient alpha of 0.93.
- Moreover, a seven-point Likert scale ranging from (1) 'strongly disagree to (7) strongly agree were used to assess responses.

#### V. ANALYSIS OF RESULTS

PLS is a second- generation multivariate techniques that helps in construct testing of the psychometric properties of the scales used to estimate the parameters of a structural model, i.e., the strength and direction of the relationships among the model variables (Lohmoller, 1989; Fronell, 1982, 1987). PLS is applicable to small samples in estimation as well as testing and appears to converge quickly even for large models with many variables and constructs (Lohmoller, 1989).

The demographic profile indicated that most of the respondents those participated in the survey were males 62.4%, and only 37.6% of the females. Furthermore, the average age of the sample in this study is divided into four categories. Moreover, at the top category is the one comprising respondents aged 31-40, which also took the highest proportion with 258 respondents, which was 48.2% of the total respondents. This indicates that the majority of the respondents have had considerable working experience. In addition, the majority of the respondents (428) were married, which made up 80%, followed by unmarried respondents, which were 107 in number and made up 20%. The educational level shows that the highest percentage of participation 50.3% was of the respondents that hold Bachelor's degrees, while (24.9%) of them had Masters Degrees, and PhD degrees made up 16%. The proportion of the respondents related to job positions were as follows 32.9%, 30.1%, 28.6, and 8.4% in the as lecture , managerial, technical and others, respectively

The data analysis employed a two-phase approach suggested by Anderson and Gerbing (1988) in order to assess the reliability and validity of the measures before using them in the research model. The first phase includes the analysis of the measurement model, while the second phase tests the structural relationships among latent constructs. The test of the measurement model involves the estimation of internal consistency reliability as well as the convergent and discriminant validity of the research instruments, which indicates the strength measures used to test the proposed model (Fronell, 1982, 1987). As shown in Table 1, all reliability measures were well above the recommended level of 0.70 as an indicator for adequate internal consistency (Hair et al., 1995; Nunnally, 1994).

**Table 1**  
*Convergent Validity Analysis*

Constructs	Items	Load ing	Cronb achs Alpha	Comp osite Reliabi lity	AVE
Trust	TRU1	0.806	0.906	0.926	0.678
	TRU2	0.851			
	TRU3	0.884			
	TRU4	0.797			
	TRU5	0.709			
	TRU6	0.880			
IBSA	IBSA1	0.880	0.748	0.841	0.582
	IBSA2	0.865			

	IBSA3	0.501			
	IBSA4	0.763			
AOT	AOT1	0.789	0.797	0.812	0.528
	AOT2	0.517			
	AOT3	0.648			
	AOT4	0.897			
RTT	RTT1	0.611	0.753	0.761	0.625
	RTT3	0.936			
RT	PRT1	0.792	0.850	0.892	0.674
	PRT2	0.821			
	PRT3	0.876			
	PRT4	0.792			
	RTT4	0.936			
TIL	TIL1	0.716	0.755	0.833	0.556
	TIL2	0.677			
	TIL4	0.823			
	TIL5	0.759			
Attitude	ATT2	0.625	0.727	0.832	0.556
	ATT3	0.726			
	ATT4	0.867			
	ATT5	0.745			
PBC	PBC1	0.758	0.891	0.926	0.757
	PBC2	0.896			
	PBC3	0.915			
	PBC4	0.902			
S N	SN1	0.792	0.859	0.899	0.641
	SN2	0.891			
	SN3	0.842			
	SN4	0.753			
	SN5	0.712			

The results of this analysis is used to accept or reject the hypotheses based on the significance of the standardised path coefficient beta weight( $\beta$ ) which illustrates how strong is the relationships among constructs. The ( $R^2$ ) value, which shows the amount of variance explained by independent variables. Both, ( $R^2$ ) and path coefficients indicate that how well the model is performing. ( $R^2$ ) shows the predictive power of the model and the value should be interpreted in the same way as ( $R^2$ ) in regression analysis. The path coefficients should be significant and consistent with expectations (Chwelos et al., 2001). To be able to conclude whether the path coefficients were statistically significant or not, this study applied the bootstrapping techniques embedded with the SmartPLS2.0.

The standardised path coefficient of 0.345 seems to indicate that attitude have a positive and statistically significant effect on IBSA and at 0.01 level of significance ( $\beta = 0.345$ ,  $t = 6.133$ ,  $p < 0.01$ ) (H6). Related to individual factors technology, there are 5 variables all of them supported with researcher expectation. The

result showed that technology and Internet literacy have a positive influence on customers' adoption of Internet banking at the 0.01 level of significance ( $\beta = 0.466$ ,  $t = 5.672$ ,  $p < 0.01$ ) (H1). Resistance to change has negative influence and significant impact on customers' adoption of Internet banking at the 0.01 level of significance ( $\beta = -0.118$ ,  $t = 2.262$ ,  $p < 0.01$ ) (H2), Risk of technology has negative influence on customers' adoption of Internet banking at the 0.01 level of significance ( $\beta = -0.125$ ,  $t = 3.818$ ,  $p < 0.01$ ) (H3), Anxiety of technology has negative influence on customers' adoption of Internet banking at 0.01 level of significance ( $\beta = -0.172$ ,  $t = 4.821$ ,  $p < 0.01$ ) (H4). Finally, trust of technology positive and statistically significant effect on IBSA at 0.01 level of significance ( $\beta = 0.221$ ,  $t = 6.087$ ,  $p < 0.01$ ) which mean that the H5 is supported.

In this study, there was only one hypotheses unsupported, H7 is explained the relationship between subjective norms and IBSA, this relation appeared significantly and negatively influences depend on ( $\beta = -0.151$ ,  $t$  value = 3.736, and  $p < 0.01$ ). All result of hypotheses shown in table 2.

**Table 2**  
*Assessment of the structural mode*

H	$\beta$	(STERR )	T	P value	Decision
H1: TIL-> IBSA	0.466	0.082	5.672	0.000 ***	SUP
H2: RTT-> IBSA	-0.118	0.052	2.262	0.024 **	SUP
H3: PRT-> IBSA	-0.125	0.033	3.818	0.000 ***	SUP
H4: AOT -> IBSA	-0.172	0.036	4.821	0.000 ***	SUP
H5: TRU-> IBSA	0.221	0.036	6.087	0.000 ***	SUP
H6: ATT-> IBSA	0.617	0.047	12.93	0.000 ***	SUP
H7: SN -> IBSA	-0.151	0.040	3.736	0.000 ***	UNSUP
H8: PBC- > IBSA	0.099	0.034	2.911	0.002 ***	SUP

## VI. DISCUSSION AND CONCLUSION

This study based on TPB model to provide a comprehensive model to understand the potential factors of Internet Banking Adoption in Iraq. This study applied partial least squares structural equation modeling (PLS-SEM) as the major analysis technique as well as SPSS, since PLS SEM is a relatively new analytical technique in construction. As shown in table 2, the

hypotheses (H1, H2,H3,H4,H5,H6,H8) were statistically supported by the findings of the study, while hypotheses of, H7 was not supported. This could be because IBS in Iraq is still in initial stages of implementation. Therefore, referent groups are unable to provide the needed information and recommendations. The aim of this research is to investigate the factors that influence adopters to continue adopt Internet banking in Iraq. 535 questionnaires were used for data analysis.

These findings may help the policy makers and service providers to arrive at better policies and strategies for future development in Internet banking or mobile banking. It also can be a major reason why some bank customers are not willing to adopt Internet banking. Without a clear understanding of internet banking usage, banks need to put more efforts to improve their Internet banking services. It will also help bank executives to formulate new strategies that could significantly affect IBSA among their customers. Higher acceptance should augment their organization's competitiveness in the market. Moreover, after determining these antecedents; the banks could work on developing and improving their relationships with their clients. The researcher expects the findings to help the banks to provide their clients with appropriate IBS, and assist them to make the right decisions by providing what they need so that they become more inclined to adopt IBS.

This study has some limitations which would indeed open opportunities for future research. For example this study focuses on the investigations of the antecedents of IBSA in Iraq; it neglects other aspects, such as the effect of the banks that provide IBS. Finally, this study discusses some antecedents of IBSA but neglects others, such as the cost, motivation, service quality, website features, etc.

#### REFERENCES

- [1] AbuShanab, E., Pearson, J., & Setterstrom, A. (2010). Internet banking and customers' acceptance in Jordan: The unified model's perspective. *Communications of the Association for Information Systems*, 26 (23), 493-524.
- [2] Ajzen, I. (1991). The theory of planned behavior. *Organizational behavior and human decision processes*, 50(2), 179-211.
- [3] Ajzen, I., Fishbein, M. (1980). *Understanding attitudes and predicting social behaviour*: Prentice-Hall Englewood Cliffs, NJ.
- [4] Akinci, S., Aksoy, S. and Atilgan, E. (2004). Adoption of internet banking among sophisticated consumer segments in an advanced developing country, *International Journal of Bank Marketing*, 22(3), 212-32.
- [5] Alagheband, P. (2006). Adoption of electronic banking services by Iranian customers. Master's thesis, Luella University of Technology, Sweden
- [6] Al-majali, M. M., & Mat, N. K. N. (2010b). Applications of planned behavior theory on internet banking services adoption in Jordan: Structural equation modeling approach. *China-USA Business Review*, 9(12), 1-12.
- [7] Al-majali, M., & Mat, N. K. N. (2011). Modeling the antecedents of internet banking service adoption (IBSA) in Jordan: A structural equation modelling (SEM) approach. *Journal of Internet Banking and Commerce*, 16(1), 1-15.
- [8] Al-majali, M. (2011). The Use of Theory Reasoned of Action to Study Information Technology in Jordan. *Journal of Internet Banking and Commerce*, 16(2), 1-11.
- [9] Alnsour, M., & Al-Hyari, K. (2011). Internet Banking and Jordanian Corporate Customers: Issues of Security and Trust. *Journal of Internet Banking and Commerce*, 16(1), 1-14.
- [10] Alsajjan, B., & Dennis, C. (2010). Internet banking acceptance model: cross-market examination. *Journal of Business Research*, 63(9/10), 957-963
- [11] Al-Somali, S. A., Gholami, R., & Clegg, B. (2009). An investigation into the acceptance of online banking in Saudi Arabia. *Technovation*, 29(2), 130-141.
- [12] Anderson, J.C., & Gerbing, D.W. (1988). Structural equation modeling in practice: A review and recommended two-step approach. *Psychological bulletin*, 103(3), 411.
- [13] Avirutha, A.(2012).The Adoption of Social Media to Enhance Performance of Small and medium Businesses in Thailand. *Business and Information, Sapporo*, 3(5)164-182.
- [14] Awamleh, R., & Fernandes, C. (2006). Diffusion of Internet banking amongst educated consumers in high income non-OECD country. *Journal of International Banking and Commerce*, 11(3).
- [15] Bradley, L., & Stewart, K. (2003). The diffusion of online banking. *Journal of Marketing Management*, 19(9-10), 1087-1109.
- [16] Celik, H. (2008). What determines Turkish customers' acceptance of internet banking? *International Journal of Bank Marketing*, 26(5), 353-370.
- [17] Chang, E. C., & Tseng, Y. F. (2011). Research note: E-store image, perceived value and perceived risk. *Journal of Business Research*. 10(6), 1-7.
- [18] Chan, S. C., & Lu, M. T. (2004). Understanding internet banking adoption and use behavior: a Hong Kong perspective. *Journal of Global Information Management (JGIM)*, 12(3), 21-43.
- [19] Cheah, C. M., Teo, A. C., Sim, J. J., Oon, K. H., & Tan, B. I. (2011). Factors affecting Malaysian mobile banking adoption: An empirical analysis. *International Journal of Network and Mobile Technologies*, 2(3), 149-160.
- [20] Chwelos, P., Benbasat, I., & Dexter, A. S. (2001). Research report: empirical test of an EDI adoption model. *Information systems research*, 12(3), 304-321.
- [21] Compeau, D. R., & Higgins, C. A. (1995). Computer self-efficacy: Development of a measure and initial test. *MIS quarterly*, 19(2), 189-211.
- [22] Dauda, Y., Santhapparaj, A., Asirvatham, D., & Raman, M. (2007). The Impact of E commerce Security, and National Environment on Consumer adoption of Internet Banking in Malaysia and Singapore. *Journal of Internet Banking and Commerce*, 12(2), 1-20.
- [23]
- [24] Dewan, N. A., Lorenzi, N. M., & Zheng, S. (2004). Overcoming Resistance to New Technology. *Behavioral Health Management*, 21(1), 28-33.
- [25] Featherman, M. S., & Pavlou, P. A. (2003). Predicting e-services adoption: a perceived risk facets perspective. *International Journal of Human-Computer Studies*, 59(4), 451-474.
- [26] Foon, S. Y., & Fah, Y. C. (2011). Internet banking adoption in Kuala Lumpur: an application of UTAUT model. *International Journal of Business and Management*, 6(4), 161-167.
- [27] Fornell, C. (1982). *A Second Generation of Multivariate Analysis: Measurement and Evaluation (Vol. 2)*: Praeger Publishers.
- [28] Fornell, C., & Wernerfelt, B. (1987). Defensive marketing strategy by customer complaint management: a theoretical analysis. *Journal of Marketing research*, 337-346.
- [29] Frankfort-Nachmias, C. & Nachmias, D. (1996). *Research Methods in the Social Sciences*, 5th ed. St. Martin's Press: London.
- [30] Fusilier, M., & Durlabhji, S. (2005). An exploration of student internet use in India: the technology acceptance model and the theory of planned behaviour. *Campus-Wide Information Systems*, 22(4), 233-246.
- [31] George, J. F. (2004). The theory of planned behavior and Internet purchasing. *Internet research*, 14(3), 198-212.
- [32] Gerrard, P., & Cunningham, B. J. (2003). The diffusion of Internet banking among Singapore consumers. *International Journal of Bank Marketing*, 21(1), 16-28. <http://dx.doi.org/10.1108/02652320310457776>
- [33] Gerrard, P., Cunningham, J., & Devlin, J. (2006). Why consumers are not using internet banking: a qualitative study. *Journal of Services Marketing*, 20(3), 160-168.
- [34] Gopi, M., & Ramayah, T. (2007). Applicability of theory of planned behavior in predicting intention to trade online: some evidence from a developing country. *International Journal of Emerging Markets*, 2(4), 348-360.
- [35] Hair, J. F., Jr., Anderson, R. E., Tatham, R. L. and Black, W. C. (1995) *Multivariate Data Analysis*, 3rd ed, Macmillan Publishing Company, New York.



- [36] Hernandez, J. M. C., & Mazzon, J. A. (2007). Adoption of internet banking: proposition and implementation of an integrated methodology approach. *International Journal of Bank Marketing*, 25(2), 72-88.
- [37] Hoehle, H., Scornavacca, E., & Huff, S. (2012). Three decades of research on consumer adoption and utilization of electronic banking channels: A literature analysis. *Decision Support Systems*, 1-11.
- [38] Hong, Y., Teh, B., Vinayan, G., Soh, C., Khan, N., & Ong, T. (2013). Investigating the Factors Influence Adoption of Internet Banking in Malaysia: Adopters Perspective. *International Journal of Business and Management*; 19(8), 24-31.
- [39] Ibrahim, I. (2012). Factors Underpinning Usage Behavior of an Electronic Filing System: The Case of Malaysian Personal Taxpayers. Australian Tax Teachers Association (ATTA) Conference. Retrieved on sept.2012 from: [http://sydney.edu.au/law/parsons/ATTA/docs\\_pdfs/conference\\_papers/Ibrahim.pdf](http://sydney.edu.au/law/parsons/ATTA/docs_pdfs/conference_papers/Ibrahim.pdf)
- [40] International Research and Exchanges Board. (2011). Bringing banks to the masses by phone. Retrieved on 20/12/2012 from <http://www.marketresearchworld.net/content/view/4432/77/>
- [41] Ipbl.(2012).Iraqi Private Bank league. Electronic banking need to make laws. Retrieved on 1/10/2012 from: <http://ipbl-iraq.org/ArticleShow.aspx?ID=111>
- [42] ITU (2010). Percentage of Individuals [user in Iraq]. Retrieved on 1/2/2012 from: <http://www.itu.int/ITU-D/ict/statistics/>
- [43] Jalal, A., Marzooq, J., & Nabi, H. A. (2011). Evaluating the Impacts of Online Banking Factors on Motivating the Process of E-banking. *Journal of Management and Sustainability*, 1(1), 1-32.
- [44] Karjaluoto, H., Mattila, M., & Pentto, T. (2002). Electronic banking in Finland: consumer beliefs and reactions to a new delivery channel. *Journal of Financial Services Marketing*, 6(4), 346-361.
- [45] KIB (2012). Retrieved on 12/4/2012 from: <http://www.kiitsc.com/ar/index.php>.
- [46] Kim, K., & Prabhakar, B. (2000). Initial trust, perceived risk, and the adoption of internet banking. In Proceedings of the twenty first international conference on Information systems. Association for Information Systems, 537-543.
- [47] Laforet, S., & Li, X. (2005). Consumers' attitudes towards online and mobile banking in China. *International Journal of Bank Marketing*, 23(5), 362-380.
- [48] Lee, J. L., Lee, K. T., & Eastwood, D. (2003). A two-step estimation consumer adoption or technology-based service. *Journal of Consumer Affairs*, 29(2), 256-27. <http://dx.doi.org/10.1111/j.1745-6606.2003.tb00453.x>
- [49] Lohmöller, J.B. (1987). LVPLS program manual, version 1.8, Technical report: Zentral archive für empirische Sozialforschung.
- [50] Lu, Y., Yang, S., Chau, P. Y., & Cao, Y. (2011). Dynamics between the trust transfer process and intention to use mobile payment services: A cross-environment perspective. *Information & Management*, 48(8), 393-403.
- [51] Luo, X., Li, H., Zhang, J., & Shim, J. P. (2010). Examining multi-dimensional trust and multi-faceted risk in initial acceptance of emerging technologies: An empirical study of mobile banking services. *Decision Support Systems*, 49(2), 222-234.
- [52] Mahdi, M. O. S. (2011). Trust and security of electronic banking services in Saudi commercial banks: Saudis versus Non Saudis opinions. *African Journal of Business Management*, 5(14), 5524-5535.
- [53] Mansumittrchai, S & Chiu, C. (2012). Adoption of internet banking in UAE: Factors Underlying Adoption Characteristics. *International Journal of management and marketing Research*, 5(1), 103-115.
- [54] Mattsson, J., & Helmersson, H. (2005). Internet banking: modelling the e-competence of customers with a text-analytic CIT approach. *International Journal of Bank Marketing*, 23(6), 470-483.
- [55] Mayer, R.C; Davis, J.H.; & Schoorman, F.D.(1995). An integrative model of organizational trust. *Academy of Management Review*, 20(3), 709-734.
- [56] Moheer (2012). Minister of higher Education Science and Research. Public Universities. Retrieved on 10/10/2012 from: <http://www.moheer.gov.iq/PageViewer.aspx?id=16>
- [57] Mohsen, A. (2010). Factors influencing the customer's choice of electronic banking, a study in a sample of customers Iraqi banks. Mustansiriyah University, pp.1-16, Available at: <http://www.shatharat.net/vb/showthread.php?t=11857> [accessed 3 July 2011]
- [58] Mukherjee, A., Nath, P., & Pal, M. (2003). Resource, service quality and performance triad: a framework for measuring efficiency of banking services. *Journal of the Operational Research Society*, 54(1), 723-735.
- [59] Nasri, W. (2011). Factors Influencing the Adoption of Internet Banking in Tunisia. *International Journal of Business and Management* 6(8), 143-160.
- [60] Ndubisi, N. O., & Sinti, Q. (2006). Consumer attitudes, system's characteristics and internet banking adoption in Malaysia. *Management Research News*, 29(1/2), 16-27.
- [61] Niqash. (2012). Cash only: why the messy banking sector endangers Iraqi Development. Retrieved on September 8, 2012 from: <http://www.niqash.org/articles/?id=3002&lang=en>
- [62] Nor, K. M., & Pearson, J. M. (2008). An exploratory study into the adoption of internet banking in a developing country: Malaysia. *Journal of Internet Commerce*, 7(1), 29-73.
- [63] Nunnally, J.C., & Bernstein, I.H. (1994). *Psychometric theory*. McGraw, New York.
- [64] Ok, S. J., & Shon, J. H. (2006). The determinant of internet banking usage behavior in Korea: a comparison of two theoretical models. 1-15. <http://citeseerx.ist.psu.edu/viewdoc/download?doi=10.1.1.97.3786&rep=rep1&type=pdf>
- [65] Pedersen, P., & Nysveen, H., (2004). Using the theory of planned behaviour to explain teenagers' adoption of text messaging services. Working Paper, Agder University College, July, 14, 2005, 1-36. Retrieved on 10, March, 2012 from: <http://mdfoo.s3.amazonaws.com/brij Singh/175547709709bb988bf8259830528e25/10.1.1.20.2242.pdf>
- [66] Pikkarainen, T., Pikkarainen, K., Karjaluoto, H., & Pahlila, S. (2004). Consumer acceptance of online banking: an extension of the technology acceptance model. *Internet Research*, 14(3), 224-235.
- [67] Polasik, M., & Wisniewski, P. T. (2009). Empirical analysis of Internet banking in Poland. *International Journal of Bank Marketing*, 27(1), 32-52.
- [68] Raman, M., Stephenaus, R., Alam, N., & Kuppusamy, M. (2008). Information Technology in Malaysia: E-service quality and Uptake of Internet banking. *Journal of Internet Banking and Commerce*, 13(2), 1-18.
- [69] Raymond, L. (1985). Organisational characteristics and MIS success in the context of small business, *Management Information System Quarterly*, 9(1), 37-52.
- [70] Rotchanakitumnuai, S., & Speece, M. (2003). Barriers to internet banking adoption: a qualitative study among corporate customers in Thailand. *International Journal of Bank Marketing*, 21(6/7), 312-323.
- [71] Sathye, M. (1999). Adoption of internet banking by Australian consumers: an empirical investigation. *International Journal of Bank Marketing*, 17(7), 324-334.
- [72] Shendi, A. (2011). Patterns and electronic banking options Acceptance and rejection. College of Business and Economics - University of Wasit, Prof. Dr. Adib Qasim Shendi. Retrieved on 11 March 2012 from: [www.iasj.net/iasj?func=fulltext&aid=53361](http://www.iasj.net/iasj?func=fulltext&aid=53361).
- [73] Shi, W., Shambare, N., & Wang, J. (2008). The adoption of internet banking: An institutional theory perspective. *Journal of Financial Services Marketing*, 12(4), 272-286.
- [74] Shih, Y. Y., & Fang, K. (2004). The use of a decomposed theory of planned behavior to study Internet banking in Taiwan. *Internet Research*, 14(3), 213-223.
- [75] Sonja, G. K., & Ewald A. K. (2003). Empirical Research in Online rust : A review And Critical Assessment. *International Journal of Human-Computer Studies*, 58(6), 783-812.
- [76] Sugathi, B., & Balachandran. (2001). Internet banking patronage: an empirical investigation of Malaysia. *Journal of Internet Banking and Commerce*, 6(1).
- [77] Suh, B., & Han, I. (2002). Effect of trust on customer acceptance of Internet banking. *Electronic Commerce Research and Applications*, 1(2002), 247-263.
- [78] Tan, M., & Teo, T. (2000). Factors influencing the adoption of Internet banking. *Journal of the Association for Information Sciences*, 1(5), 1-42.
- [79] Taylor, S., & Todd, P. A. (1995). Understanding information technology usage: A test of competing models. *Information systems research*, 6(2), 144-176.

- [80] Thompson, Ronald L., Christopher A. Higgins, and Jane M. Howell. Personal computing: toward a conceptual model of utilization. *MIS quarterly* (1991): 125-143.
- [81] Venkatesh, V., Morris, M. G., Davis, G. B., & Davis, F. D. (2003). User acceptance of information technology: toward a unified view. *MIS Quarterly*, 27(3), 425-478.
- [82] Wallis, S. (1997). *Financial System Inquiry final report: overview*. Sydney, Australia: Australian Government Publishing Service.
- [83] Wang, T. L. (2011, June). An effect of trust and attitude in the initial adoption of online shopping: An empirical study. In *Information Society (i-Society), 2011 International Conference IEEE*, 22-26.
- [84] Yang, S., Lu, Y., Gupta, S., Cao, Y., & Zhang, R. (2012). Mobile payment services adoption across time: An empirical study of the effects of behavioral beliefs, social influences, and personal traits. *Computers in Human Behavior*, 28(1), 129-142.
- [85] Zmud, R.W. (1979). Individual differences and MIS success: a review of the empirical literature. *Management Science*, 25(10), 966-979.

#### AUTHORS

**First Author-** Alaa Ahmed Chyad Alkafagi, Universiti Utara Malaysia, School of Technology Management & Logistics  
E-mail: [alaalaco@gmail.com](mailto:alaalaco@gmail.com); [alaco\\_75@yahoo.com](mailto:alaco_75@yahoo.com),

**Second Author-** Ruslan Bin Romli, Universiti Utara Malaysia, School of Technology Management & Logistics

**Third Author-** Ahmad Yusni Bin Bahaudin, Universiti Utara Malaysia, School of Technology Management & Logistics

**Fourth Author-** Jamal Mohammed Alekam, Universiti Utara Malaysia

**Corresponding Author-** Alaa Ahmed Chyad Alkafagi, Universiti Utara Malaysia, School of Technology Management & Logistics., E-mail: [alaco\\_75@yahoo.com](mailto:alaco_75@yahoo.com); [alaalaco@gmail.com](mailto:alaalaco@gmail.com);

## **Appendix: Measurement Scale of Constructs**

### **IBSA:**

- 1- I find internet banking is useful for managing my financial matters.
- 2- I believe internet banking is an easy way to conduct banking activities.
- 3- I find that internet banking is encouraging.
- 4- I feel fast internet access speed is important in internet banking

### **Attitude**

- 1-Using Internet banking is a good idea.
- 2-I like the idea of using internet banking.
- 3-Using internet is a pleasant idea.
- 4-Using internet banking is an appealing idea.
- 5-Using internet banking is an exciting idea.

### **Subjective Norm (SN)**

- 1-People who influence my behavior think that I should use internet banking.
- 2-People who are important to me think that I should use internet banking.
- 3-People whose opinions I value think I should use internet banking.
- 4-People who are close to me think that I should use internet banking.
- 5-People who influence my decisions think that I should use internet banking.

### **Perceived Behavior control (PBC)**

- 1 – I would be able to operate internet banking.
- 2- I have the resources to use internet banking.
- 3- I have the knowledge to use internet banking.
- 4- I have the ability to use internet banking.

### **Internet Technology Literacy(ITL)**

- 1-I feel comfortable when using computers in general.
- 2-I feel comfortable when using the internet technology.
- 3-I am satisfied with my current skills for using the internet
- 4-I believe computer literate keeps me using internet banking services
- 5-I believe Internet literate keeps me using internet banking services

### **Resistant to Technology(RTT)**

- 1- I am interested to hear about new technological developments.
- 2- Technological developments have enhanced our lives.
- 3- I feel comfortable in changing and using internet banking services for my financial activities.
- 4- I like to experiment with new technologies such as Internet banking services

### **Risk of Technology (PRT)**

- 1- I believe that money can be easily stolen while using Internet banking.

- 2- I believe that the decision to transact using IB is risky.
- 3- I believe that the decision to transact using IB is negative.
- 4- I am afraid that other people might get access to information about my Internet banking transactions

### **Anxiety of Technology (AOT)**

- 1-I feel nervous about using Internet banking.
- 2-It scares me to think that I could lose a lot of information using internet banking by hitting the wrong key.
- 3-I hesitate to use internet banking for fear of making mistakes I cannot correct.
- 4-The using of internet banking is somewhat intimidating to me.

### **Trust of Technology(TRU)**

- 1- This Internet banking site is trustworthy.
- 2- I trust in the benefits of the decisions of this Internet banking site.
- 3- This Internet banking site keeps its promises and commitments.
- 4- This Internet banking site keeps customers' best interests in mind.
- 5- This Internet banking site would do the job right even if not monitored.
- 6-I trust this Internet banking site.

# Adenoid Cystic Carcinoma of Nasal Cavity: A Rare Presentation Case Report

Dr P K Purushothaman\*, Dr R Ramakrishnan\*\*, Dr P Sindhu\*\*

\*MS, Professor, Department of ENT, SRM Medical College Hospital and Research Centre

\*\* Post Graduate Resident, Department of ENT, SRM Medical College Hospital and Research Centre,

**Abstract-** Adenoid cystic carcinoma (ACC) is one of the commonest malignant salivary gland tumors, affecting minor salivary glands and rare in the nose and paranasal sinuses. ACC in maxillary sinus usually mimic inflammatory disease and has a poor prognosis. A case report of 37 yr old male with ACC of left nasal cavity who presented with mass in left nasal cavity and swelling in left cheek is presented here. The CT scan showed mass in left nasal cavity and over frontal process of maxilla with bone resorption. Surgical excision was done by Lateral Rhinotomy approach and biopsy revealed ACC. Post op radiotherapy given and regular follow up done. The sinonasal ACC has an overall poor prognosis due to perineural invasion and post-operative radiotherapy is important to address the microscopic disease.

**Index Terms-** Adenoid cystic carcinoma, Nasal cavity, Paranasal sinuses

## I. INTRODUCTION

Adenoid cystic carcinoma (ACC) is a malignant tumor of head and neck region, including trachea, bronchus, lung and mammary gland. It is an epithelial non epidermoid tumor and occurrences in the head and neck region are relatively rare. They arise most commonly in the major salivary gland, oral cavity, and pharynx and paranasal sinus. Clinical features of ACC are different from those of squamous cell carcinoma and thus we must be aware of its characteristics for the diagnosis and treatment.

Adenoid cystic carcinoma most commonly involves the salivary gland tissue and is the second most common tumor of nasal cavity and paranasal sinuses. Sinonasal ACC accounts for 10-25% of all head and neck ACC. Sinonasal tumors are often asymptomatic and mimic inflammatory disorders leading to delay in diagnosis. Many patients present with advanced-stage disease and extensive involvement of surrounding structures including the dura, brain, orbits, carotids, and cranial nerves. In addition, ACC has a propensity for perineural spread and bony invasion, which can lead to significant skull base involvement and intracranial extension. These findings make treating sinonasal ACC challenging and potentially morbid.

ACC was first described by Billroth in 1856. Growth patterns are characterized as cribriform, tubular and solid. As the cribriform pattern of the tumor forms cylindrical accumulations of basal lumina, glycosaminoglycans and stroma, the term cylindroma had been applied in the past. We have reviewed the clinical features, treatments and prognostic factors in a patient

who had undergone the primary treatment for ACC in our institution.

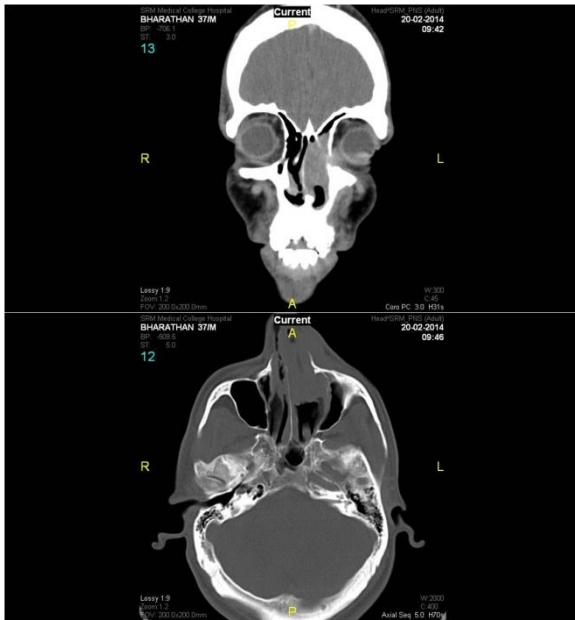
## II. CASE PRESENTATION

A 37 year old male patient presented with complaints of left sided nasal block and left sided blood stained nasal discharge for the past 6 months. He also complained of swelling over left side of cheek along with headache and left sided facial pain for 6 months. Patient had similar complaints in the past for which he was twice operated 2 years ago. There were no associated comorbidities. On local examination, a mass over left maxilla was palpated which was hard and tender measuring about 4x3cms with superior extension up to infraorbital margin. Anterior rhinoscopy showed a mass in the left nasal cavity, which appeared congested. No other extension was noted and no neck nodes were palpable.

On Diagnostic Nasal Endoscopy (DNE), mass was seen between left inferior turbinate and the septum involving the lateral wall of nose. The mass was firm, appeared congested and was bleeding minimally on touch.



CT Paranasal sinus revealed a unilateral soft tissue mass involving left nasal cavity causing expansion of left nasal cavity and thinning of neighboring bone, with extension of mass into medial part of anterior wall of left maxilla with associated bone resorption.



Patient was taken up for elective surgery under general anaesthesia. Tumour was approached by left Lateral Rhinotomy (Moure's incision). The mass was delineated completely. The mass was found involving the lamina papyracea, frontal process of maxilla, medial part of anterior wall of left maxilla below the infraorbital rim. The orbit was lifted and the anterior ethmoid artery was ligated. Periorbita was found intact. The whole mass was removed in toto along with lamina papyracea, eroded frontal process of maxilla, eroded anterior wall of maxilla and sent for histopathological examination (HPE). After removal of the mass, the bony walls were drilled thoroughly.



HPE reported the specimen as Adenoid Cystic Carcinoma. The histological examination revealed malignant neoplasm in cribriform, tubular and focally solid pattern in myxoid and hyalinised stroma. The tumor cells showed hyperchromatic ovoid nuclei and scanty cytoplasm with peripheral pallisading. Spaces in the tubules contained basophilic mucinous material. The tumor was infiltrating into the bone, surrounding adipose tissue, skeletal muscle and focally showed perineural invasion. Rare mitosis was seen. The tumor was staged as a Stage IV tumor (T4N0M0).

The patient was sent for Radiation therapy following surgery after 3 weeks. A total of 30 cycles (60Gy) was given over 6 weeks. After completion of radiotherapy he is on regular follow-up at monthly intervals. Patient is asymptomatic and post

operative DNE shows nasal cavity free from tumor. There were no neck nodes palpable.

### III. DISCUSSION

ACC is a minor salivary gland tumor that can arise in nasal cavity and paranasal sinuses and the second most common malignancy next to squamous cell carcinoma.<sup>1, 2</sup> Maxillary sinus is most common site for ACC followed by nasal cavity.<sup>1, 3, 4</sup> There are studies which indicate that surgery followed by radiotherapy is the most common treatment for patients with sinonasal ACC, which was the treatment given in our case.<sup>5, 6</sup> Though ACC is considered a radiosensitive tumor, it should be always combined with surgery because radiotherapy can give adequate clearance of positive margins left behind after surgery.<sup>8</sup> The recurrence rate after surgery is due to perineural invasion. Overall 5-year survival rates for patients with sinonasal ACC from 50% to 86% have been reported.<sup>1, 4, 9</sup>

Spiro et al observed patients with ACC of maxillary sinus had advanced disease due to tissue and bony invasion.<sup>9</sup> The cause of pain is due to neoplastic cell neurotropism and this was a significant complaint in our patient also.<sup>10</sup> Recurrence and decrease in survival rate is due to intraneural, perineural infiltration and positive margins.<sup>11</sup> Solid variant shows greater aggressiveness.<sup>12</sup> The Prognosis of ACC tumor is influenced by its location with tumors of maxillary region having the worst prognosis.<sup>11</sup>

Recently, numerous studies have shown benefit with locoregional control and long survival for ACC patients when surgery and radiotherapy are combined, especially for those with unfavorable prognosticators such as advanced lesion.<sup>13, 14</sup> Therefore, some authors postulate that postoperative radiation likely delays rather than prevents recurrence.<sup>9, 15</sup> The rate of recurrence for solid tumors is 100% and low grade variants are 59-89%. Irrespective of surgery and radiotherapy, the overall recurrence rate of sinonasal ACC is 65%. The distant metastasis is usually seen in lung and bone, which is around 35-50%. The 10 year survival rate is usually less than 20%.

### CONCLUSION

Thus ACC is a rare tumor and most patients present in a late stage. The prognostic factors are based on site, stage, histopathological subtype of the tumor. Poor prognostic indicators are solid type, grading, skull base and neural invasion. High index of suspicion is required for early diagnosis and optimal management.

### REFERENCES

- [1] Rhee CS, Won TB, Lee CH, et al. Adenoid cystic carcinoma of the sinonasal tract: treatment results. *Laryngoscope*. 2006; 116:982-986.
- [2] Cruz Perez DE, Pires FR, Lopes MA, de Almeida OP, Kowalski LP. Adenoid cystic carcinoma and mucoepidermoid carcinoma of the maxillary sinus: report of a 44-year experience of 25 cases from a single institution. *J Oral Maxillofac Surg*. 2006; 64: 1592-1597.
- [3] Dulguerov P, Jacobsen MS, Allal AS, Lehmann W, Calcaterra T. Nasal and paranasal sinus carcinoma: are we making progress? A series of 220 patients and a systematic review. *Cancer*. 2001;92:3012-3029.

- [4] Myers LL, Nussenbaum B, Bradford CR, Teknos TN, Esclamado RM, Wolf GT. Paranasal sinus malignancies: an 18-year single institution experience. *Laryngoscope*. 2002; 112: 1964–1969.
- [5] Katz TS, Mendenhall WM, Morris CG, Amdur RJ, Hinerman RW, Villaret DB. Malignant tumors of the nasal cavity and paranasal sinuses. *Head Neck*. 2002; 24: 821–829.
- [6] Wiseman SM, Popat SR, Rigual NR, et al. Adenoid cystic carcinoma of the paranasal sinuses or nasal cavity: a 40-year review of 35 cases. *Ear Nose Throat J*. 2002; 81: 510–517.
- [7] Leafstedt SW, Gaeta JF, Sako K, Marchetta FC, Shedd DP. Adenoid cystic carcinoma of major and minor salivary glands. *Am J Surg*. 1971; 122: 756–762.
- [8] Garden AS, Weber RS, Morrison WH, Ang KK, Peters LJ. The influence of positive margins and nerve invasion in adenoid cystic carcinoma of the head and neck treated with surgery and radiation. *Int J Radiat Oncol Biol Phys*. 1995; 32: 619–626.
- [9] Spiro RH. Distant metastasis in adenoid cystic carcinoma of salivary origin. *Am J Surg*. 1997; 174: 495–498.
- [10] Ellis GR, Auclair PL. Atlas of tumor pathology- tumors of the salivary glands [CD-ROM]. Washington D.C.: Armed Forces Institute of Pathology; 1996
- [11] Jones AS, Hamilton JW, Rowley H, Husband D, Helliwell TR. Adenoid cystic carcinoma of the head and neck. *Clin Otolaryngol Allied Sci* 1997;22(5):434-43.
- [12] Chummun S, Mc Lean NR, Kelly CG, Dawes PJD, Meikle D, Fellowst S, et al. Adenoidcystic carcinoma of the head and neck. *Br J Plast Surg* 2001;54(6):476-80.
- [13] Garden AS, Weber RS, Morrison WH, et al. The influence of positive margins and nerve invasion in adenoid cystic carcinoma of the head and neck treated with surgery and radiation. *Int J Radiat Oncol Biol Phys*, 32 (1995), pp. 619–626.
- [14] Mendenhall WM, Morris CG, Amdur RJ, et al. Radiotherapy alone or combined with surgery for adenoid cystic carcinoma of the head and neck. *Head Neck*, 26 (2004), pp. 154–162.
- [15] Katz TS, Mendenhall WM, Morris CG. Malignant tumors of the nasal cavity and Paranasal sinuses. *Head Neck*. 2002;24:821-9.

#### AUTHORS

**First Author :** Dr P KPurushothaman , MS, Professor,  
Department of ENT, SRM Medical College Hospital and  
Research Centre, entpurush@gmail.com.

**Second Author :** Dr R Ramakrishnan , MS, Associate Professor,  
Department of ENT, SRM Medical College Hospital and  
Research Centre, openupramki@gmail.com.

**Third Author :** Dr P Sindhu, Post Graduate Resident,  
Department of ENT, SRM Medical College Hospital and  
Research Centre, [drsindhu2011@gmail.com](mailto:drsindhu2011@gmail.com).

**Correspondence Author :** Dr P KPurushothaman, MS,  
Professor, Department of ENT, SRM Medical College Hospital  
and Research Centre, entpurush@gmail.com, 9840723243.



# GM Food and Sustainable Development

Dr. Afrina Rizvi

Associate Professor, Dept. of Mass Communication, Aligarh Muslim University, Aligarh, UP-202002 India

**Abstract-** Global food production has seen a phenomenal growth of almost three times in the last five decades. Unfortunately, still a sizeable section of people in developing and poor countries remain hungry and malnourished. New strategies are therefore needed to not only feed the hungry in an healthy and nourishing way but also to protect the environment from overuse of chemical pesticides and insecticides, thus maintaining a balance with nature too. Advances in agricultural biotechnology have led to genetically modified varieties of many plants and crops like cotton, maize, soya, tomato, and brinjal etc. In India too, a genetically modified variety of cotton, Bt cotton has been cultivated since 2002, which is said to provide resistance against bollworm. However, commercial use of Bt brinjal, a genetically modified variety of brinjal, has been put on hold. In the present scenario role of mass media become vital. Mass media are important not only for giving the real picture behind the use of a particular technology; they can also provide relevant information necessary to make a judicious choice about the kind of food one wants to have. Keeping this in view, contents of major English dailies are analyzed both quantitatively and qualitatively to find out how recent controversies over genetically modified food and crops are framed by these newspapers.

**Index Terms-** GM Food, Sustainable development, Agricultural Biotechnology, Bt brinjal, English Dailies

## I. INTRODUCTION

Owing to advancement in agricultural science and technology, global food production has almost trebled in the last 50 years. This phenomenal rise has somehow managed to keep pace with growth in human population and with efficient distribution policies of food grains; most of the global population could be covered. However, unfortunately, still a sizeable section of people in developing and poor countries remain hungry and malnourished. New strategies are therefore needed to not only feed the hungry in an healthy and nourishing way but also to protect the environment from overuse of chemical pesticides and insecticides, thus maintaining a balance with nature too. In other words easily affordable, nutritious food produced in a sustainable manner is the need of the hour. At the same time the environmental degradation caused by use of modern agricultural methods has to be reversed, as soil damage, ample and continuous supply of water and energy and overall change in climate continue to pose challenges and uncertainties for the farmers.

Advances in agricultural biotechnology have led to genetically modified varieties of many plants and crops like cotton, maize, soya, tomato, and brinjal etc. The general term used for such genetically manipulated varieties is GMO's or

genetically modified organisms and in most cases an extra gene is added to give resistance from pest and insects to these plants and crops. In India too, a genetically modified variety of cotton, Bt cotton has been cultivated since 2002, which is said to provide resistance against bollworm. However, commercial use of Bt brinjal, a genetically modified variety of brinjal, claimed to provide resistance against pests like Brinjal Fruit and Shoot Borer (BFBS) and fruit borer, has been put on hold.

While environmentalists like Vandana Shiva term GM crops a threat to country's biodiversity and stress upon the need to promote organic farming for sustainable and natural growth of agriculture in the future, a large number of scientists in India and abroad still favour cultivation of GM crops in a controlled manner for an improved yield.

All this makes the field of Agri-biotechnology highly controversial. Undoubtedly this particular field of biotechnology offers immense potentialities not only in terms of developing high yielding varieties but also creating such varieties as Bt Cotton and Bt brinjal which are pest resistant thus likely to yield better crops and benefits to the farmers.

However whether these varieties are sustainable and conducive to the environment remains a million dollar question. The debate gets more heated when it comes to cultivation of genetically modified varieties in developing countries like India. Besides their highly doubtful environmentally sustainable nature GMO's pose other kinds of problems too. When it comes to the interests of the small farmers and their dependence on Multinational Companies for seeds besides high levels of irrigation required for such varieties, no ready solutions seem to be available. Also in the absence of strict regulations of labelling of GMO's in the market, consumers too are likely to feel confused or cheated when it comes to making a choice between buying GMO's, organic or regular varieties of fruits and vegetables.

As evident, the branch of agricultural biotechnology is highly interdisciplinary and industrially oriented and thus enjoys considerable socio-economic and political significance. Biotechnology and genetics as themes have dominated the mass media too for the last 20 years in most of the developed world. In India too recent controversy on Bt Brinjal has brought the theme on the agenda of the mass media. Mass media can be effectively used to make science related issues understandable and thus making the general public aware of such issues having societal importance. An enlightened and aware public can effectively participate in the decision-making on scientific matters having societal impacts. In India, as the reader public is largely dependent on newspapers for information regarding science and technology, this particular mass medium has immense possibilities of making the general people aware on such issues.

In India, Mr Jairam Ramesh, ex Minister of State for Environment and Forests, announced a moratorium on the

environmental release of Bt Brinjal, a genetically modified variety of brinjal, after a series of countrywide consultations. The Ministry of Environment and Forests organized public meetings on Bt brinjal in seven cities between January 13 to February 6, 2010. On February 9, 2010, Mr Jairam Ramesh announced his decision to put the use of Bt brinjal on hold. Brinjal is India's second largest produced vegetable after potato.

It has been established that producing GM food which is highly input intensive produces long-term environmental impact. Such requirements, as very high irrigation puts unsustainable demands on aquifers and damage to aquatic ecosystems. Moreover data suggests that using GM technology has benefited mostly big farmers with large lands and irrigation facilities. There are serious concerns like that of loss of biodiversity too. After green revolution, intensive cultivation of high-yielding varieties resulted in the loss of many wild varieties with higher nutritional levels.

Advances in genetically modified varieties are mostly driven by private multi-national companies and in developing countries too their commercial cultivation are governed by global market laws. Green Revolution on the other hand was financed by public sector bodies.

Out of 1.6 billion hectares of the cultivated land area which is about 12 per cent of world's land area, 80 per cent is dependent on rains for irrigation. This area is responsible for producing 60 per cent of the world's crop. For the rest of crop production there is a very heavy strain on natural sources of water like rivers, lakes and aquifers for irrigation. According to latest estimates, about 70 per cent of all water taken from naturally occurring sources is used for irrigating the crops.

In the present scenario role of mass media become vital. Mass media are important not only for giving the real picture behind the use of a particular technology; they can also provide relevant information necessary to make a judicious choice about the kind of food one wants to have.

Researchers suggest that portrayal of an issue by the mass media also known as framing plays an important role in the formation of public opinion. Media framing could be defined as the ways in which the media choose to portray the issues they cover. Framing analysis has established the fact that the media imparts a certain perspective, or a "spin" to the events that they cover and this in turn might influence public attitude on an issue. Framing analysis has been called the second level of agenda setting.

According to Tankard media frame is a central organizing idea for news content that supplies a context and suggests what the issue is through the use of election, emphasis, exclusion and elaboration. Mass media, it is argued, frame social phenomena 'by ignoring it, blurring the news in the back section, repeating or stressing' thus suggesting what to think about or provide a way of thinking. Another function associated with framing is the assigning of responsibility for social problems. Today issues like stem cells, cloning and GM food and crops remain highly controversial and biotechnology seems to be setting new political agendas worldwide. As mentioned earlier in India Bt cotton is still not viewed favorably by a considerable section of the society and more transparency is demanded into the functioning of Genetic Engineering Approval Committee (GEAC) now renamed Genetic Engineering Appraisal Committee when it comes to

introducing GM food and crops into the market. Doubts and questions have already been raised regarding the safety of GM foods, the labeling of GM consumer products and the environmental impacts of GM crops. The role of MNC's in the agricultural economy remains highly questionable and governmental policies are also under public scanner.

Keeping this in view, contents of major English dailies are analyzed both quantitatively and qualitatively to find out how recent controversies over genetically modified food and crops are framed by these newspapers.

News frames are defined as "conceptual tools which media and individuals rely on to convey, interpret and evaluate information" (Newman et al.1992). Although journalists can use a multitude of ways to frame the news, the literature seems to point to at least four ways in which news is commonly framed (Valkenberg et al, 1999):

By emphasizing conflict between parties or individuals (conflict frame)

By focusing on an individual as an example or by emphasizing emotions (human interest frame)

By attributing responsibility, crediting or blaming certain political institutions (responsibility frame)

By focusing on the economic consequences for the audience (economic consequences frame)

Bucchi and Mazzolini (2007) talk of presence of a marked dualism as far as coverage of science by the daily press between two distinct journalistic genres. They have named these two genres respectively as science-popularization (science-oriented public communication of science) and science-as-news (problem-oriented communication of science). According to them the genre of science popularization depicts science as straightforward, consensual, and as bringing improvements to peoples' lives. The other genre of science-as-news pays closer attention to controversy and to the harmful consequences of the scientific enterprise.

## II. OBJECTIVES

To analyze the coverage of major English dailies both quantitatively and qualitatively on genetically modified food and crops.

To find out the frequency of news on GM food and crops in major English dailies

To find out the placement and sources of news of GM food and crops.

To ascertain in what tones, context and perspectives GM foods and crops are covered by major newspapers in India.

To find out how recent controversy over genetically modified food and crops are framed by these newspapers.

To find out the roles played by different stakeholders during nationwide public consultations on commercialization of Bt brinjal.

To find out the role played by NGOs and social activists in promoting public participation on the issue of commercialization of Bt brinjal.

### III. METHODOLOGY

Content analysis both quantitative and qualitative is used to assess the coverage of debate on GM food and crops in two major English dailies. For this study two English broadsheet dailies, The Times of India and The Hindu are analyzed. These two newspapers are selected because of their high circulation and their different political alignments.

The Times of India with a circulation of 3.43 million is the largest circulated English newspapers in the world across all formats. Aligned as classical liberal, it has a readership of 7.03 million.

The Hindu, with a circulation of 1.46 million, is the second-largest circulated daily English newspaper in India after Times of India. A left of centre newspaper, it enjoys a readership of 2.15 million.

Coverage of recent controversy regarding GM food and crops after the approval of Bt Brinjal for commercial use by Genetic Engineering Approval Committee on October 14, 2009

was followed by countrywide consultations on this issue which finally resulted in the moratorium imposed by Minister of Environment and Forest, Mr Jairam Ramesh.

Contents of the two newspapers were searched and analysed with the help of computer with unit of analysis being words. Online versions of the two newspapers The Times of India and The Hindu were analysed for a period of one year i.e. from October 1, 2009 to September 30, 2010. News stories and editorials were selected on the basis of Headline information. All the news stories as well as editorials having the words “Bt brinjal” in either the headline or lead paragraph were selected.

News content of the two newspapers on Bt Brinjal were also analysed for their frequency, sources and placement. To find out how recent controversy over genetically modified food and crops are framed by these newspapers, news was coded in four commonly used framed by the journalists (conflict, human interest, responsibility and economic consequences).

#### *News Coverage of GM Food and Crops*

	<b>The Hindu (N=49)</b>	<b>The Times of India (N=47)</b>
<b>Front Page</b>	12	06
<b>Editorial</b>	01	06
<b>Source of News</b>		
(a) By-line	18	20
(b) Special Correspondent	14	-
(c) Agencies	03	-
(d) Staff Reporter	13	21
<b>Number of words</b>	15188	25151

*Framing of GM Food and Crops*

	<b>The Hindu (N=49)</b>	<b>The Times of India (N=47)</b>
<b>Conflict</b>	22	19
<b>Human Interest</b>	22	28
<b>Responsibility</b>	01	-
<b>Economic</b>	04	-

IV. FINDINGS AND DISCUSSION

While The Times of India enjoys a better coverage (number of words being much higher) number of stories is almost equal suggesting thus that in case of The Times of India, there are more detailed news items.

However, there are 12 front page news stories in The Hindu against 6 of The Times of India which shows more prominence being given by The Hindu to the coverage of GM food and crops. On the other hand interestingly, The Times of India carries six editorials against one of The Hindu. As far as sources of news are concerned, both the newspapers seem to rely on their own staff and networks, at the same time giving almost equal number of by-lines.

Columns in The Times of India are written by such people as activists, regular columnists and corporate.

Columns in The Times of India are written by such people as activists, regular columnists and corporate.

As far as framing of news on GM food and crops is concerned there is a marked difference. While The Times of India relies heavily on human interest frame with 28 out of its 47 news stories written in this particular frame, The Hindu is presenting news items in mainly two frames; conflict and human interest. Rest of the news stories in The Hindu are presented in responsibility and economic frame.

News stories written in human interest frame in both the newspapers raise such issues as nationalism, reliance on foreign

firm at the cost of indigenous knowledge and loss of biodiversity apart from health concerns.

The Hindu being left of centre also raises the issue of dependence on Monsanto, an American seed giant for cultivation of Bt brinjal. Mahyco, a subsidiary of Monsanto is responsible for distribution of Bt brinjal seeds in India.

News stories written in conflict frame show NGOs, farmers and social activists articulating their views against commercial cultivation of Bt brinjal. Authorities both scientific and political (ministers) are shown pitted against each other.

While the Agriculture Minister Mr. Sharad Pawar is all for Bt brinjal, Minister of Science, Technology and Earth Sciences supports the scientists but would not mind more field trials. Scientists such as Swaminathan, father of Green Revolution and Bhargava are openly against commercial use of Bt brinjal.

V. CONCLUSION

When it comes to covering controversies on science which by their very nature are political newspapers seem to be taking clear stands which become apparent from their editorials. Moreover importance of commercial introduction of Bt brinjal in Indian market has added further scope for debate.

[1] Bucchi M, Mazzolini RG (2007) Big science, little news: Science coverage in the Italian daily press, 1946–1997. In: Bauer M, Bucchi M (eds) Journalism, Science and Society: Science Communication between News and Public Relations. New York: Routledge, pp. 53–70.

- [2] Gamson WA, Modigliani A (1989) Media discourse and public opinion on nuclear power: A constructionist approach. *American Journal of Sociology* 95: 1–37.
- [3] Iyengar S (1991) *Is Anyone Responsible? How Television Frames Political Issues*. Chicago: University of Chicago Press.
- [4] Fjæstad B (2007) Why journalists report science as they do. In: Bauer M, Bucchi M (eds) *Journalism, Science and Society: Science Communication between News and Public Relations*. New York: Routledge, pp. 123–131.
- [5] Goffman E (1974) *Frame Analysis*. New York: Free Press.
- [6] Gitlin T (1980) *The Whole World is Watching*. Berkeley: University of California Press.
- [7] Nisbet MC (2010) Knowledge into action: Framing the debates over climate change and poverty. In: D'Angelo P, Kuypers JA (eds) *Doing News Framing Analysis: Empirical and Theoretical Perspectives*. New York: Routledge, pp. 43–83.
- [8] Nissani M (1999) Media coverage of the greenhouse effect. *Population and Environment* 21 (September): 27–33.
- [9] Gamson WA (1992) *Talking Politics*. New York: Cambridge University Press.
- [10] Newman, W. R., Just, M.R., & Crigler, A. N. (1992). *Common knowledge: News and the construction of political meaning*. Chicago: University of Chicago Press.
- [11] Valkenburg, P. M., Semetko, H. A., & de Vreese, C. H. (1999). The effects of news frames on readers' thoughts and recall. *Communication Research*, 26, 550-569.

#### AUTHORS

**First Author** – Dr. Afrina Rizvi, Associate Professor, Dept. of Mass Communication, Aligarh Muslim University, Aligarh, UP-202002 India

# Analysis of resection margins and lymph node dissection in laparoscopic assisted pancreatico-duodenectomy

KB Galketiya\*, MVG Pinto\*\*

\* Consultant surgeon/ senior lecturer, Faculty of medicine, University of Peradeniya, Sri Lanka

\*\* Consultant anaesthetist/ senior lecturer, Faculty of medicine, University of Peradeniya, Sri Lanka

**Abstract-** Laparoscopic assisted pancreatico-duodenectomy is expected to minimize patient discomfort, blood loss and enable early feeding, mobilization and discharge; thus reducing institutional costs. It has a steep learning curve. We are presenting the adequacy of resection with regards to resection margins and lymph node harvest of our series.

**Index Terms-** laparoscopy, pancreatico-duodenectomy, resection margins, lymph node evaluation

## I. INTRODUCTION

Pancreatico-duodenectomy is the surgical treatment of choice for carcinoma of the peri ampullary region and head of pancreas. The open procedure is associated with considerable morbidity and occasional mortality. The long incision, continuous handling and prolonged use of retractors can result in post operative respiratory inadequacy due to severe pain and ileus. There is often significant blood loss. Laparoscopic assisted pancreatico-duodenectomy is an achievable alternative minimizing post-operative complications, thus facilitating early feeding, mobilization and discharge from hospital(1,2,4,6,9).

Laparoscopic pancreatico-duodenectomy necessitates a steep, stepwise learning curve and literature indicates the need of further studies to recommend its routine use.(4,5,6,7,8,9).

A resection margin free of tumour need to be performed. Prognostic value of the ratio of involved lymph nodes to evaluated lymph nodes is shown in many studies(10,11,12).

We have evaluated the resection margins and lymph node clearance of our series.

## II. PATIENTS AND METHOD

Patients were assessed for co-morbidities and optimized as required. Procedures were carried out under general anaesthesia supplemented by epidural analgesia.

We used five ports. Pneumoperitoneum was created by insufflation of CO<sub>2</sub> at a pressure of 14 mmHg. The gastro-colic ligament was divided to enter the lesser sac. Colon was mobilized from the mid transverse colon to caecum. The duodenum was identified and 'kocherized' and the inferior vena cava was exposed until the left renal vein crossed the abdominal aorta. Duodenal mobilization was continued until division of the ligament of Treitz

Subsequently the portal vein was exposed to the neck of pancreas. Dissection continued until the common bile duct and common hepatic artery were exposed. This was followed by clipping and division of the gastro-duodenal artery. Stomach was transected using staplers and the pancreas was divided in front of the portal vein. The jejunum was transected using staplers.

The gall bladder was separated from the liver bed and division of the common hepatic duct completed the resection.

A mid line laparotomy of not exceeding 10 cm was adequate to retrieve the specimen and perform the anastomoses - pancreatico-jejuno-stomy, hepatico-jejuno-stomy and gastro-jejuno-stomy(9).

The resection margins and lymph node clearance were analyzed.

## III. RESULTS

Twenty patients underwent surgery over two years.

Laparoscopic Dissection done up to	Portal vein dissection	Supra-duodenal dissection	Division of stomach and pancreas	Complete resection
Number of patients	10	05	03	02
Resection margins free of tumour	Yes	yes	Yes	Yes
Lymph node harvested in specimen	8-12	10-14	12-14	10-14

Table -stage performed with laparoscopy, resection margins and lymph node clearance

In all patients irrespective of the stage of conversion the resection margins were free of tumour. There was no difference of lymph node clearance as well.



#### IV. DISCUSSION

Laparoscopic pancreaticoduodenectomy poses a steep and challenging learning curve for a surgeon. The usefulness and progress in laparoscopic pancreaticoduodenectomy with necessity for hand assisted or hybrid adaptations was reviewed by Gagner and Palermo in 2009.

Adaptation to a sequential learning curve requiring conversion to open surgery at varying stages of the procedure due to lack of progress or risk of bleeding was practised for the safety of the patient. Prior experience of the open technique is a necessity (9).

Tumour free resection margins were achieved irrespective of the stage of laparoscopy, facilitated by evaluation of pre-operative imaging. The amount of lymph nodes cleared was also not affected which was comparative to that obtained by open pancreaticoduodenectomies done in our unit. However the median lymph nodes evaluated in published data are higher than in our series (10).

#### V. CONCLUSIONS

Sequential surgical progression towards laparoscopic pancreaticoduodenectomy was practiced to minimize patient discomfort, blood loss and enable early feeding, mobilization and discharge; thus reducing institutional costs. The resection margins were free of tumour with comparable lymph node clearance irrespective of the stage of conversion, just as in open procedure.

Therefore adequate tumour and lymph node clearance were not limiting factors during the learning curve of laparoscopic assisted pancreaticoduodenectomy, in our series.

#### REFERENCES

- [1] Gagner M, Palermo M. Laparoscopic Whipple procedure: review of the literature. *J Hepatobiliary Pancreat Surg.* 2009;16(6):726-30. doi: 10.1007/s00534-009-0142-2. Epub 2009 Jul 28.
- [2] Dulucq JL, Wintringer P, Stabilini C, Feryn T, Perissat J, Mahajna A. Are major laparoscopic pancreatic resections worthwhile? A prospective study of 32 patients in a single institution. *Surg Endosc.* 2005 Aug;19(8):1028-34. Epub 2005 May 26.
- [3] Lee JS, Han JH, Na GH, Choi HJ, Hong TH, You YK, Kim DG. Laparoscopic pancreaticoduodenectomy assisted by mini-laparotomy. *JSLs.* 2013 Jan-Mar;17(1):68-73.
- [4] Lei P, Wei B, Guo W, Wei H. Minimally Invasive Surgical Approach Compared With Open Pancreaticoduodenectomy: A Systematic Review and Meta-analysis on the Feasibility and Safety. *Surg Laparosc Endosc Percutan Tech.* 2014 Apr 16. [Epub ahead of print]
- [5] Tan-Tam C, Chung SW. Minireview on laparoscopic hepatobiliary and pancreatic surgery. *World J Gastrointest Endosc.* 2014 Mar 16;6(3):60-67.
- [6] Nigri G, Petrucciani N, La Torre M, Magistri P, Valabrega S, Aurello P, Ramacciato G. Duodenopancreatectomy: Open or minimally invasive approach? *Surgeon.* 2014 Feb 10. pii: S1479-666X(14)00012-2. doi: 10.1016/j.surge.2014.01.006. [Epub ahead of print]
- [7] Bao PQ, Mazirka PO, Watkins KT. Retrospective Comparison of Robot-Assisted Minimally Invasive Versus Open Pancreaticoduodenectomy for

Periampullary Neoplasms. *J Gastrointest Surg.* 2013 Nov 15. [Epub ahead of print]

- [8] Zenoni SA, Arnoletti JP, de la Fuente SG. Recent developments in surgery: minimally invasive approaches for patients requiring pancreaticoduodenectomy. *JAMA Surg.* 2013 Dec;148(12):1154-7. doi: 10.1001/jamasurg.2013.366.
- [9] KB Galketiya, V Pinto. The sequential pathway to the first laparoscopic resection with mini-laparotomy anastomosis for pancreaticoduodenectomy (Whipple's) in Sri Lanka. *International Journal of Scientific and Research Publications.* 2014;4(12);1-2
- [10] T M. Pawlik, A L Gleisner, J L. Cameron, JM. Winter, L Assumpcao, K D. Lillemoe, C Wolfgang, R H Hruban, R D. Schulick, C J Yeo, M A. Choti. Prognostic relevance of lymph node ratio following pancreaticoduodenectomy for pancreatic cancer. *Surgery.* 141(5); 610-618
- [11] H Riedinger, T Keck, U Wellner, A Hausen, U Adam, UT Hopt, F Makowiec. The lymph node ratio is the strongest prognostic factor after resection of pancreatic cancer. *Journal of gastrointestinal surgery* 2009;13(7); 1337-1344
- [12] TM Pawlik, AL Gleisner, SL Cameron, JM Winter, L Assumpcao, KD Lillemoe, C Wolfgang, RH Hruban, RD Schulick, CJ Yeo, MA Choti. Prognostic relevance of lymph node ratio following pancreaticoduodenectomy for pancreatic cancer. *Surgery* 2007;141(5); 610-118

#### AUTHORS

**First Author** – KB Galketiya, Consultant surgeon/ senior lecturer, Faculty of medicine, University of Peradeniya, Sri Lanka, email: kbgalketiya@yahoo.com, Telephone-0094777884008

**Second Author** – MVG Pinto, Consultant anaesthetist/ senior lecturer, Faculty of medicine, University of Peradeniya, Sri Lanka

# A conceptual linkage between knowledge management, competitive advantage and competitive maneuverings of organizations

Kashif Akram\*, Nasir Mehmood\*\*, Imran Khan\*\*\*

\* PhD scholar at COB,OYABSB,UUM, Malaysia

\*\* MS (MS) Scholar at University of South Asia, Lahore, Lecturer at the department of Management science

\*\*\*The Islamia university of Bahawalpur, Pakistan

**Abstract-** Knowledge management has emerged important field that captured an attention of research scholar in the field of management as KM promulgated important source of competitive advantage. The basic purpose of the study is to explore conceptual linkage between knowledge management and organization's strategy formulation and competitive advantage. Detailed literature is reviewed to find out conceptual linkage between knowledge management, strategy formulation and competitive advantage. We used resources based view approach to link strategy and competitive advantage as a lens. This research would be fruitful for managers to understand strategic importance of knowledge, knowledge management and knowledge strategy to attain sustainable competitive advantage.

## I. INTRODUCTION

Today's companies facing radical and incremental technological advancements, continues changes in customer's taste, preferences, demand and fierce global competition which is creating more turbulence, dynamism and complexity in the world business (Johannessen and Olsen, 2009). The only way to compete and attain distinctive competence to get sustainable competitive advantage is, to more focus on company's strategic planning (Halawi and McCarthy, 2006). Knowledge economy has changed the overall experience of knowledge worker which is more enriched with skills and competencies.

Organizations reconfiguring their Business models to link knowledge management and business strategy. Knowledge acquisition, sharing and application are key sources of competitive advantage (Sheng and chang, 2013). Almost every organization possesses knowledge assets and competing business strategies but often they fail to link both to gain sustainable competitive advantage. Many studies identified knowledge as key source of competitive advantage (Sheng and chang, 2013; Johannessen and Olsen, 2009; Cuganesan and Silvi, 2006; Watanabe and senoo, 2009). Knowledge is latest and important strategy to increase competitiveness of the organization (Bell and Jackson, 2001). Stephen Demming's story about World Bank's transition from large centralized and bureaucratic organization to knowledge management organization is quite impressive. It reveals that what organization has to do to transform itself from conventional centralized and bureaucratic organization to knowledge based or knowledge organization and how overall

business strategy links with knowledge management. Moreover what happens when knowledge based view takes place in the organization whether it is small or large organization (Ruggles and Holtshouse, 1999). Treating knowledge as crucial and valuable asset to gain competitive advantage is getting common (Zack, 1999). Still many people think that knowledge management is only related to IT field. The strong linkage of KM and company's business strategy is lacking. Our basic objective is to identify the linkage between KM and organization's business and competitive strategy, whether or not knowledge management and competitive strategy has link with each other to gain sustainable competitive advantage. We go through from detailed literature on both knowledge management and firm's business or competitive strategy to fit both in order to attain sustainable competitive strategy.

## II. MODELS OF STRATEGY

This section discusses the Porter's five forces model and resource based view of the firm (RBV) (Warnerfelt, 1984).

### Porters' Five forces model:

Strengths, weaknesses, opportunities and threats (SWOT) analysis is dominating for several years over porter's five forces model. Degree of competition in an industry is determined through five forces model. It also tells us about the competitiveness of the industry and favorability for investors, whether or not enter into a particular industry. Porter's five forces include bargaining power of buyer, bargaining power of supplier, Threat of new entrant, Threat of substitution and rivalry among existing players (Porter, 1979). The model helps the organization to formulate their strategies and analyze the forces that are causes of opportunities and threats in external environment of business. Barney (1995) stated that the organization that identify opportunities abstain from threats, identify and exploit strength and overcome weaknesses would gain sustainable competitive advantage than their rivals.

### Firm's Resource Based view

Sustainable competitive advantage is key element in today's hypercompetitive market. Valuable, Rare and inimitable resources are necessary to gain sustainable competitive advantage (Barney, 1991). Resource based view (RBV) has its roots in work of Penrose (1959). Resource based theory delineates that resources and competencies of the firms effect the growth and performance (Penrose, 1959; Barney, 1991;

Mahoney and Pandian, 1992). RBV focuses resources and competencies which are difficult to imitate and pivotal for sustainable competitive advantage (Barney, 1991; Dierickx and coll, 1989; Peteraf, 1993). Firms possess different types of resources broadly tangible and intangible human and non human that help the organization to formulate value enriched organizational strategies (Barney, 1991; Warnerfelt, 1984). Resources that are rare, valuable, inimitable and non substitutable constitute organization's distinctive competencies therefore provided sustainable competitive advantage (Barney, 1991; Prahalad and Hamel, 1990). Intangible knowledge assets provide more sustainable competitive advantage because intangible knowledge assets are difficult to imitate (Hitt, 2001, Akram et al, 2011). Intangible resources like knowledge, tend to add more value to other organization resources and competencies (Hitt, 2011). Barney (1991) asserted that distinctive resources allow firms to formulate and implement their strategies in effective and efficient manner. Furthermore he proposed criteria to analyze, which kind of resources can give sustainable competitive advantage like inimitability, non-substitutability, rarity compared to competition and value delivery for customers. It is understood that knowledge is a vital source to gain competitive advantage (Halawi et al, 2006). Knowledge resources are hard to transfer and imitate, so organization must focus internally to utilize and implement such distinctive resources (Barney, 1991; Prahalad and Hamel, 1990; Mahoney and Pandian, 1992; Collis and Montgomery, 1995; Post, 1997; Markides, 1997). Firm's resource building has greater impact on firm's strategies (Barney, 1996). They guide firms to take effective decisions to gain sustainable competitive advantage (Grant, 1991).

### III. KNOWLEDGE MANAGEMENT

Knowledge is still a vague concept and plethora definitions of knowledge can be found in literature of knowledge management. Davenport and Prusak (1998) defined knowledge as it is mixture of human context and information that enable information more actionable.

Sanchez (1996) defined knowledge as ability to sustain the harmonized utilization of resources and capabilities in a way that assures the accomplishments of strategic objectives.

O'Dell and Grayson (1998) defined as "knowledge to be information in action".

Murray (1998) analyzed that knowledge management strategy turns organizational intellectual assets both talent and recorded information in competitive manner. It creates more competitiveness and value for organizations because it develops skills and competencies among managers and employees. They also learn how to enhance capabilities and skills on individual and collective level.

Knowledge management is multi-disciplinary field ranging from cognitive sciences, artificial intelligence, technology, innovation process, and expert to knowledge based system (Murray, 2000). KM may reveal to convergence of ideas promulgated over the years including RBV theory, core competencies, balance scorecard, information management, dynamic capabilities view, information mapping, learning organizations and intellectual assets (Corrall, 1998). There are

various aspects and methodologies which focus on different beliefs of KM that highlight knowledge is an important aspect to be handled. It focuses on to acquire right knowledge at the right time in the right form and disseminate and share to the right person (Halawai et al, 2006). KM is definitely an organizational process that aims to make centralize knowledge source in the organization that absorb, distribute, assimilate, share, retrieve and reuse the interior and external, explicit and tacit knowledge to bring innovation in the organization such as the product, process and people of organization (Akram et al, 2011). Organizations also need to focus on appropriate KM infrastructure as theory suggests, its process is simple but its implementation is quite complex task. Firms must describe clear policies that direct the implementation of KM infrastructure. Organization should develop supportive culture as well which places value on culture (Shepard, 2000). Finally we need to understand that KM solutions are just 10 to 20 % related to technology efforts but culture and behavioral and managerial efforts are major to it.

### Strategy formulation and KM

Grant (1991) defined strategy as "The match an organization makes between its internal resources and skills, and opportunities, and risk created by external environment".

"Strategy comes from the interaction between firm and its environment as well as knowledge worker and management" (Nurme, 1998).

We can define strategy as long term direction of firm to gain competitive advantage by utilizing its resources and competencies in highly turbulent and dynamic environment.

### The fundamental question is how strategy or strategy formulation and knowledge are linked with each other?

Fahay (1996) asserted that strategy formulation and knowledge both are multifaceted, dynamic and complex concepts. These are not simple concepts to be understood and implemented. A firm's strategy shows the current strategic position and future intent of the organization. Strategy reveals the strategic intent of the organization, whether organization would pursue with the same strategy, resources and competencies in future or it would change everything.

Organization's knowledge strategy includes diverse fields like customers, competitors, bankers, technology, suppliers, financial and marketing intermediaries. Firms should implement its strategy in a way that knowledge could make it thrive. Organization can analyze its strategy in a way that how strategy takes benefits of exiting knowledge assets. Organization must identify and analyze the possibilities of knowledge and strategy linkage to attain sustainable competitive advantage. Zack (1999) suggested that, to exploit the linkage of strategy and knowledge organizations must formulate their strategic plan, identify the knowledge gap and then fill that gap through knowledge strategy fit.

### IV. KM STRATEGIES

The fundamental purpose of knowledge management strategy is knowledge creation, codification, transfer and implementation

of explicit and tacit knowledge within an organization to get right information, at the right, in a right form and to the right person. There are various characteristics of knowledge management strategies

- Develops understanding about organization knowledge assets, where are they reside
- Clearly identify and delineate the role of knowledge in value creation
- Having various integrated projects expanding over time, quick wins and strategic benefits (Du Plessis, 2007).

There are four major strategies to manage knowledge in organization including culture, technology, leadership and measurement (Davenport and prusak, 1998; O'Dell and Grayson, 1998; Davenport, 1999). Knowledge strategy explains the needs, aspects, dimensions and actions to attain objectives. A knowledge strategy is different from a knowledge management strategy, which is a road map of a firm responsible for management of knowledge and various knowledge related issues to enable knowledge management, both are crucial for organization to get sustainable competitive advantage, that is why must be aligned continuously (Hofer-Alfies, 2003). Formulations of KS is relatively easy and simple (clark; 1998) process include , perfect scenario for current and future intense competitive environment, Find with respect to the future profitable, Identify personnel within organization who possess the knowledge or having knowledge acquisition capability and model companies efforts on footsteps of those companies who are conceptually ideal. An organizational KM strategy must reveal its competitive strategy. KM strategy must drive by competitive strategy (Civi, 2000). Mckinsey Quaterly (1998), "the first step in framing a knowledge strategy is to understand

four characteristics specifically: extraordinary leverage and increasing returns since knowledge is not subject to diminishing returns, uncertain value since the value of an investment in knowledge is frequently hard to guess, uncertain value sharing and fragmentation, leakage and the need for refreshment".

Wig (1997) explored five underlying knowledge centered strategies, some organizations practice it as business strategy where main attention is on capturing creation sharing, renewal and implementation in all areas and activities of organization. Some organization takes it as intellectual asset management strategy which include patents customer relationship, organization structural capital and enterprise management level. A third approach personal knowledge strategy. It focuses on to highlight each person liability about knowledge management. Knowledge creation strategy focuses on overall organizational continues learning, research, innovation, learn from past, and acquire fresh and unique knowledge to enhance competitiveness. Knowledge transfer strategy is related to transfer knowledge across the organization and to adopt and acquire best practice. Drew (1999) found that how business managers can use KM into their strategy formulation process. He suggested that organization must build KM in their various activities like, strategy formulation, vision, mission, core competence and environmental scanning. He explores four categories of business knowledge.

- 1). What we know, we know,
- 2). What we know, we don't know.
- 3). What we don't know, we know
- 4). What we don't know, we don't know

**Table 1**

Knowledge awareness/ knowledge content	1. What we know we know	2. What we know we don't know	3. What we don't know we know	4. What we don't know we don't know
Emphasis	Knowledge sharing, access and inventory	Knowledge seeking and creation	Uncovering hidden or tacit knowledge	Discovering key risks, exposures and opportunities
Tools	Benchmarking, communities of practice	R&D, market research, competitive intelligence	Knowledge maps, audits, training and networks	Creative tension, audits, dilemmas, complexity science

Source: Adapted from Drew (1999)

He added that several knowledge initiatives and program are related to the first of these. What we know, we know. It means sharing best practices within the organization. From strategic perspective its fourth type of knowledge what we don't know, we don't know that creates fierce opportunities and threats. When organization manages these four areas and develops knowledge dimensions to use strategy tools, organization take first and important initiative to develop knowledge based strategy where, distinctive knowledge driven factors of competitive advantage can provide inimitability for competitors and deliver value to customer beyond expectations. Broadbent (1998) stated that objective of an organization to be more competitive due to ability, adoptability and innovation of its employs. They can mitigate loss of intellectual capital, decreasing cost by attaining economy of scale through getting information from outside, Control wastage of knowledge based activities, Increase productivity by disseminating and sharing knowledge and above all through KMS organizations want to get competitive advantage in market place (Knapp, 1998).

Zack (1996) stated that, by performing SWOT organization can give support to their knowledge resources while formulating their business strategy. A survey was conducted in 1999 which was conducted on 200 IT managers. Those 94% managers consider KM as a strategic issue for organization (Stahl, 1999). There are six core strategies through organizations use to compete more efficiently and effectively with knowledge by strengthening and promoting in culture of information sharing (APQC, 1999). These strategic factors have greater impact on employee's readiness to share knowledge and ties and connection with core cultural values, business strategy, integration with daily work, role of human networks and role of leadership, reward and resignation. Organization should give incentives to gain competitive advantage (1996). Bierly and Chakrabarty (1996) empirically tested various generic strategies to acquire and develop knowledge focusing on US pharmaceutical industry. Several authors worked on knowledge and strategy integration in recent years.

Author(s)	Category
Jalal, et al. (2013)	Competitive Advantage
Sheng et al. (2013)	Competitive Advantage
Sigalas, et al. (2013)	Competitive Advantage
Kamukama et al. (2011)	Intellectual Capital and CA
Johannessen and Olsen (2009)	Knowledge Management and CA
Watanabe and Senoo (2009)	Knowledge Management and CA
(Jon-Arild, 2009)	

#### V. KNOWLEDGE MANAGEMENT STRATEGY AND CHALLENGES

A knowledge management strategy is critical to successful programs of knowledge management (Kavindri, 2005; KPMG, 2000; Parlbly and Taylor, 2000; Robertson, 2005). Challenges are same for knowledge management strategy and organization strategy in today's competitive world.

Alignment of organization vision, strategic objectives and strategies with organization strategic business units and with individual knowledge workers efforts are major problems. Measurement of key performance indicators includes, top management should clearly formulate the strategic objectives and share with SBU, moreover aligned them with operational level strategies (Clark, 1997). In same manner knowledge should be aligned with business process and decisions making form strategic to operational level (Shaw and Edwards, 2005; Greiner et al. 2007).

Business process is link to organizational business strategies, so it's logical for knowledge management strategy to focus on business process (Duplessis, 2007). Knowledge strategy and business strategy linkage involve various classifications like core, support, and strategic knowledge (Osborne, 2004) exploratory and exploitative (Curado, 2008; Earl 2001) and ephemeral and core (Leseure and Brookes, 2004). Knowledge alignments are not limited to just classification but it goes on further, to focus on strategic knowledge on strategic process, support knowledge on support process and core knowledge on core process (Shaw and Edward 2005).

There are various companies that demonstrated zest and commitment to link knowledge management and their corporate strategy, business processes, organization culture and HR practices hence they reap sustainable competitive advantage in their respective industry and areas like, Siemens, GE, World bank and IBM etc. But among these organization Siemens most successfully linked and aligned their KM strategy and corporate strategy to gain sustain able competitive advantage.

Siemens is diverse multi level and large organization that is possessing verity of products and businesses. Technology adoption and implementation makes Siemens different form its rivals. Siemens adopted knowledge management relatively early as compare to its competitors. Siemens commenced and accomplished various knowledge management projects on groups, regions and global level.

Siemens is facing various challenges related to global knowledge based business and companywide knowledge management solutions to disseminate or share existing knowledge and producing new knowledge (Hofer-Alfeis, 2003). KM includes knowledge strategy sharing, competence building, knowledge creation and implementation in all areas of organization structures culture and linking KM strategy with corporate strategic planning. Siemens transformation from conventional to KM organization is quite impressive. KM implementation at Siemens is quite evident in the form of its decentralized approach, competency building initiatives linkage of knowledge with its strategic planning. Due to these initiatives knowledge has embedded in culture and structure of the company. Siemens products and services are more knowledge based. Siemens was started KMS (knowledge management strategy process) to determine and formulate strategy and action plan.

#### VI. DISCUSSION AND CONCLUSION

Knowledge based economy is very reality of today's world. There are various issues, problems, and challenges regarding implementations and measurement of knowledge management

strategy, but many organizations including small medium and large adopting it. We try to create a conceptual linkage between KM strategy and business strategy of the firm by reviewing literature on KM and business strategy utilizing lens of RBV. As economies have converged from technology driven economies to knowledge driven economies, fundamental resource to be remain in market and get sustainable advantage is knowledge linkage of KM strategy and corporate business strategy.

A company discuss in current study is distinct in implementation and alignment of KMS and business strategy. So company reaping tangible benefits. The linked KM strategy and business strategy in way, it's successfully nurture knowledge sharing, acquisition and implementation culture that drives innovation, competency development, agility, superior performance and consequently became sustainable competitive company. Advance organizations showed formulate and implement strategies in a way that can give sustainable competitive advantage assets of the organization. Many organization fail to understand strategic importance of their knowledge assets in maintain sustainable competitive advantage. They fail to identify strategic aspects of KM. KM must be linked to fundamental or core strategy of the organization. Many organization fail to integrate KM strategy and business strategy due lake of clearly stated business model. Companies must have reliable both practically and theoretically business model to link KM strategy.

#### REFERENCES

- [1] American Productivity and Quality Center (1999a), available at: [www.it-consultancy.com/](http://www.it-consultancy.com/)
- [2] [extern/apge.html](http://extern/apge.html).
- [3] American Productivity and Quality Center (1999b), APQC Benchmarking Study, American
- [4] Productivity and Quality Center, Houston, TX.
- [5] Amit, R.H. and Schoemaker, P.J. (1993), "Strategic assets and organizational rent", *The Resource-Based View of the Firm*, Vol. 14, pp. 33-46.
- [6] Anonymous (1995), "The rise of the knowledge worker", *Civilization*, Vol. 2 No. 1, p. 19.
- [7] Barclay, R.O. (2000), *Leading the Knowledge Enterprise CIOs, CLOs and Beyond*, Corporate
- [8] Education.Biz, LCC, NY, available at: [www.ktic.com/topic6/13\\_LEAD.HTM](http://www.ktic.com/topic6/13_LEAD.HTM).
- [9] Barclay, R.O. and Murray, P.C. (2000), *What is Knowledge Management?*, Available at: [www.media-access.com/whatis.html](http://www.media-access.com/whatis.html).
- [10] Barney, J.B. (1986), "Strategic factor markets: expectations, luck and business strategy",
- [11] *Management Science*, Vol. 32, pp. 1231-41.
- [12] Barney, J.B. (1991), "Firm resources and sustained competitive advantage", *Journal of Management*, Vol. 17 No. 1, pp. 99-120.
- [13] Barney, J.B. (1995), "Looking inside for competitive advantage", *Academy of Management Executive*, Vol. 9 No. 4, pp. 49-61.
- [14] Barney, J.B. (1996), "The resource-based theory of the firm", *Organization Science*, Vol. 7 No. 5, p.469.
- [15] Beckman, T. (1997), *A Methodology for Knowledge Management*, International Association of
- [16] Science and Technology for Development AI and Soft Computing Conference: Banff, Alberta, Canada.13,4
- [17] Bell, D.K. and Jackson, L.A. (2001), "Knowledge management: understanding theory and developing strategy", *Competitiveness Review*, Vol. 11 No. 1, pp. 1-11.
- [18] Bierly, P. and Chakrabarti, A. (1996), "Generic knowledge strategies in the U.S. pharmaceutical industry", *Strategic Management Journal*, Vol. 17, Winter, pp. 123-35.
- [19] Blackler, F. (1995), "Knowledge, knowledge work and organizations: an overview and interpretation", *Organization Studies*, Vol. 16 No. 6, pp. 1021-46.
- [20] Bogner, W.C., Thomas, H. and McGee, J. (1999), "Competence and competitive advantage toward a dynamic model", *British Academy of Management*, Vol. 10, pp. 275-90.
- [21] Broadbent, M. (1998), "The phenomenon of knowledge management: what does it mean to the information profession", *Information Outlook*, Vol. 2 No. 5, pp. 23-31.
- [22] Brown, J.S. and Duguid, P. (1998), "Organizing knowledge", *California Management Review*, Vol. 40 No. 3, pp. 90-111.
- [23] Choi, Y.S. (2000), "An empirical study of factors affecting successful implementation of knowledge management", *Doctoral Dissertation*, Graduate College at the University of Nebraska, University of Nebraska, Lincoln, NB.
- [24] Civi, E. (2000), "Knowledge management as a competitive asset: a review", *Marketing Intelligence & Planning*, Vol. 18 No. 4, pp. 166-74.
- [25] Clarke, P. (1998), "Implementing a knowledge strategy for your firm", *Research Technology Management*, Vol. 41 No. 2, pp. 28-31.
- [26] Collis, D.J. and Montgomery, C.A. (1995), "Competing on resources: strategy in the 1990s", *Harvard Business Review*, July-August, pp. 118-28.
- [27] Conner, K.R. (1991), "A historical comparison of resource-based theory and five schools of thought within industrial organization economics: do we have a new theory of the firm?", *Journal of Management*, Vol. 17 No. 1, pp. 121-54.
- [28] Corral, S. (1998), "Knowledge management: are we in the knowledge management business?", *Ariadne*, No. 18, available at: [www.ariadne.ac.uk/issue18/knowledge-mgt](http://www.ariadne.ac.uk/issue18/knowledge-mgt).
- [29] Clarke, P. (1997), "The balanced scorecard", *Accountancy Ireland*, Vol. 29 No. 3, pp. 25-6.
- [30] Curado, C. (2008), "Perceptions of knowledge management and intellectual capital in the banking industry", *Journal of Knowledge Management*, Vol. 12 No. 3, pp. 141-55.
- [31] Davenport, T.H. (1999), *Some Principles Of Knowledge Management*, McCombs Graduate School of Business, University of Texas, Austin, TX, available at: [www.mcombs.utexas.edu/kman/kmprin.htm](http://www.mcombs.utexas.edu/kman/kmprin.htm).
- [32] Davenport, T.H. and Probst, G.J.B. (2002), *Knowledge Management Case Book*, 2nd ed., John Wiley & Sons, Weinheim.
- [33] Davenport, T.H. and Prusak, L. (1998), *Working Knowledge: How Organizations Manage What They Know*, Harvard Business School Press, Boston, MA.
- [34] Davenport, T.H., De Long, D.W. and Beers, M.C. (1998), "Successful knowledge management projects", *Sloan Management Review*, Vol. 39 No. 2, pp. 43-57.
- [35] Dierickx, I. and Cool, K. (1989), "Asset stock accumulation and sustainability of competitive advantage", *Management Science*, Vol. 35 No. 12, pp. 1504-11.
- [36] Drew, S. (1999), "Building knowledge management into strategy: making sense of a new perspective", *Long Range Planning*, Vol. 32 No. 1, pp. 130-6.
- [37] Du Plessis, M. (2007), "Knowledge management: what makes complex implementations successful?", *Journal of Knowledge Management*, Vol. 11 No. 2, pp. 91-101.
- [38] Fahey, L. (1996), "Putting knowledge into strategy", *Presentation at the Ernst & Young Managing the Knowledge of the Organization Conference*, Phoenix, AZ.
- [39] Grant, R.M. (1991), "The resource based theory of competitive advantage: implications for strategy formulation", *California Management Review*, Vol. 33 No. 3, pp. 114-35.
- [40] Grant, R.M. (1995), "A knowledge-based theory of inter-firm collaboration", *Academy of Management – Best Paper Proceedings*, pp. 17-21.



- [46] Grant, R.M. (1996), "Toward a knowledge-based theory of the firm", *Strategic Management Journal*, Vol. 17, Winter, pp. 109-22.
- [47] Greiner, M., Bohmann, T. and Krcmara, H. (2007), "Strategy for knowledge management", *Knowledge Management Journal*, Vol. 11 No. 6, pp. 3-15.
- [48] Hansen, M.T., Nohria, N. and Tierney, T. (1999), "What's your strategy for managing knowledge?", *Harvard Business Review*, Vol. 77 No. 2, pp. 106-18.
- [49] Hitt, M.A., Bierman, L., Shimizu, K. and Kochhar, R. (2001), "Direct and moderating effects of human capital on strategy and performance in professional service firms: a resource-based perspective", *Academy of Management Journal*, Vol. 44 No. 1, pp. 13-28.
- [50]
- [51] Hofer-Alfeis, J. (2003), "Effective integration of knowledge management into the business starts with a top-down knowledge strategy", *Journal of Universal Computer Science*, Vol. 9 No. 7, pp. 719-28.
- [52] Johannessen, A.J. (2009), "Systematic knowledge processes, innovation and sustainable competitive advantage", *Kybernetes*, Vol. 38 NO3/4 pp. 559-580.
- [53] Knapp, E.M. (1998), "Knowledge management", *Business and Economic Review*, Vol. 44 No.4.
- [54] Kavindri, M. (2005), "Key success factors for knowledge management", available at: [www.knowledgeboard.com/cgi-bin](http://www.knowledgeboard.com/cgi-bin) (accessed 5 April 2006).
- [55] KPMG (2000), "Knowledge management research report 2000", available at: [http://www.providersedge.com/docs/km\\_articles/KPMG\\_KM\\_Research\\_Report\\_2000.pdf](http://www.providersedge.com/docs/km_articles/KPMG_KM_Research_Report_2000.pdf) (accessed 1 February 2012).
- [56] Kamukama, N. and Ahiauzi, A. (2011), "Competitive advantage: mediator of intellectual capital and performance", *Journal of intellectual capital*, Vol. 12 No. 1, pp. 152-164.
- [57] Leseure, M. and Brookes, N. (2004), "Knowledge management benchmarks for project management", *Journal of Knowledge Management*, Vol. 8 No. 1, pp. 103-16.
- [58] McCarthy, R. and Aronson, J.E. (2004), "Knowledge management at GE: a technology transfer case study", working paper.
- [59] McKinsey Quarterly (1998), "Best practice and beyond: knowledge strategies", *McKinsey Quarterly*, Vol. 1, pp. 19-25.
- [60] Mahoney, J.T. and Pandian, J.R. (1992), "The resource-based view within the conversation of strategic management", *Strategic Management Journal*, Vol. 13, pp. 363-80.
- [61] Markides, C. (1997), "Strategic innovation", *Sloan Management Review*, Spring, pp. 9-23.
- [62] Murray, P.C. (1998), *New Language For New Leverage. The Terminology of Knowledge*
- [63] Management, Corporate Education. Biz, LLC, NY, available at: [www.ktic.com/topic6/13\\_term2.htm](http://www.ktic.com/topic6/13_term2.htm).
- [64] Nurmi, R. (1998), "Knowledge-intensive firms", *Business Horizons*, May-June, pp. 26-32.
- [65] O'Dell, C. (1996), "A current review of knowledge management best practice", Conference on
- [66] Knowledge Management and the Transfer of Best Practices, Business Intelligence, London.
- [67] O'Dell, C. and Grayson, C.J. (1998), "If only we knew what we know: identification and transfer of internal best practices", *California Management Review*, Vol. 40 No. 3, pp. 154-74.
- [68] Osborne, M. (2004), "Making the most of the best: formulating a knowledge management strategy for government advisory body", *Australian Journal of Public Administration*, Vol. 63 No. 3, pp. 43-52.
- [69] Parlbly, D. and Taylor, R. (2000), "The power of knowledge: a business guide to knowledge management", available at: [www.kpmgconsulting.com/index.html](http://www.kpmgconsulting.com/index.html).
- [70] Penrose, E.T. (1959), *The Theory of the Growth of the Firm*, Wiley, New York, NY.
- [71] Peteraf, M.A. (1993), "The cornerstones of competitive advantage: a resource-based view", *Strategic Management Journal*, Vol. 14, pp. 179-91.
- [72] Porter, M.E. (1979), "How competitive forces shape strategy", *Harvard Business Review*, Vol. 57 No. 2, pp. 137-45.
- [73] Porter, M.E. (1996), "What is strategy?", *Harvard Business Review*, Vol. 74 No. 6, pp. 61-79.
- [74] Post, H.E. (1997), "Building a strategy on competences", *Long Range Planning*, Vol. 30 No. 5, pp. 733-40.
- [75] Prahalad, C.K. and Hamel, G. (1990), "The core competence of the corporation", *Harvard Business Review*, Vol. 68 No. 3, pp. 79-91.
- [76] Ruggles, R. (1998), "The state of notion: knowledge management in practice", *California Management Review*, Vol. 4 No. 3, pp. 80-9.
- [77] Ruggles, R. and Holtshouse, D. (Eds) (1999), *The Knowledge Advantage*, Capstone Publishing
- [78] Limited. Ernst & Young LLP, Dover, NH.
- [79] Robertson, J. (2005), "Intranets and knowledge sharing", available at: [www.steptwo.com.au/papers/kmc\\_intranetsknowledge/index.html](http://www.steptwo.com.au/papers/kmc_intranetsknowledge/index.html).
- [80] Sanchez, R., Heene, A. and Thomas, H. (1996), *Dynamics of Competence-based Competition*:
- [81] *Theory and Practices in the New Strategic Management*, Elsevier, Oxford.
- [82] Shepard, S. (2000), *Telecommunications Convergence*, McGraw Hill, New York, NY.
- [83] Skyrme, D.J. and Amidon, D.M. (1999), "The knowledge agenda", in Cortada, J.W. and Woods, J.A. (Eds), *The Knowledge Management Yearbook 1999-2000*, Butterworth-Heinemann, Boston, MA, pp. 109-26.
- [84] Stahl, S. (1999), "Knowledge yields impressive returns", *Information Week*, April.
- [85] Shang, L.M. (2013), "Knowledge barriers, knowledge transfer, and innovation competitive advantage in healthcare settings", *Management decision*, Vol. 51 No. 3, pp. 461-478.
- [86] Sigala, C. and Economou, P.V. (2013), "Developing a measure of competitive advantage", *Journal of strategy and management*, Vol. 6 No. 4, pp. 320-342.
- [87] Teece, D.J. (1998), "Capturing value from knowledge assets: the new economy, markets for know-how, and intangible assets", *California Management Review*, Vol. 40 No. 3, pp. 55-79.
- [88] Turban, E., McLean, E. and Wetherbe, J. (2001), *Knowledge Management. Information Technology for Management: Transforming Business in the Digital Economy*, Wiley, New York, NY, pp. 385-432.
- [89] Wernerfelt, B. (1984), "A resource-based view of the firm", *Strategic Management Journal*, Vol. 5, pp. 171-80.
- [90] Wiig, K. (1997a), "Knowledge management: an introduction and perspective", *Journal of Knowledge Management*, Vol. 1 No. 1, pp. 6-14.
- [91] Wiig, K.M. (1997b), "Knowledge management: where did it come from and where will it go?", *Expert Systems with Applications*, Vol. 13 No. 1, pp. 1-14.
- [92] Yu, D. (1999), "Building the knowledge advantage", available at: [www.pwcglobal.com](http://www.pwcglobal.com).
- [93] Zack, M. (1999a), *Knowledge and Strategy*, Butterworth-Heinemann, Boston, MA.
- [94] Zack, M.H. (1999b), "Developing a knowledge strategy", *California Management Review*, Vol. 41 No. 3, pp. 125-45.

#### AUTHORS

**First Author** – Kashif Akram, PhD scholar at COB, OYABSB, UUM, Malaysia

**Second Author** – Nasir Mehmood, MS (MS) Scholar at University of South Asia, Lahore

**Third Author** – Imran Khan, Lecturer at the department of Management science, The Islamia university of Bahawalpur, Pakistan

# Depression Global Etic Findings about Gender, Income-groups and Localities; a Comparative Study

Dr. Naveed Shibli, Hina Majid, Amana Zafar Ahsan, Amana Khalil, Moon Abdul Rauf, Salma Liaqat, Saira Yousaf, Iqbal Mehmood

**Abstract-** Depression is a global common mental disorder, the present study was designed to check the prevalence of etic findings about depression in case of localities, income groups and gender from Faisalabad, findings supported etic findings, regarding localities percentages of prevalence were high in slums as compared with high class localities whereas the presence of depression was more among high class women as compared with women belonging to low income groups.

**Index Terms-** Depression, localities, gender

## I. INTRODUCTION

Depression reflects low mood and aversion to activity and it affects thoughts, behavior and sense of well-being, (Salmans, Sandra 1997). According to European World Health Organization, depression is a “common mental disorder, characterized by sadness, loss of interest or pleasure, feelings of guilt or low self-worth, disturbed sleep or appetite, feelings of tiredness and poor concentration.” A few studies about “depression” in Pakistan reveal that there is an increase in the rate of depression in Pakistan (Rozina, Shanila 2012) moreover, during a lecture Professor Dar observed that 35.7% citizen living in Karachi are subject to depression and overall rate of depression in Pakistani population is 34% as compared with its approximate prevalence in the entire world that to her is 20%. In another gender based study conducted in Karachi 65% women belonging to upper and lower classes studied were subject to depression, (Saima, Zafar, Kazi 2012) Whereas in a past study conducted in the Iceland of Manora Karachi Pakistan among fisherman families only 7.5% women were reported to be subject to depression, (N.Nisar, Biloo, Gadit 2004)

Depression is a global issue and many similar studies are there across the cultures. In an attribution styles study a difference of ‘attribution style was found in different cultures (Craig 1999). In a similar study relationship of attribution with depression was found (Craig and Lynn 1985)

Another aspect of depression that has been widely studied is the relationship of class and depression. In one such study the relationship of socio economic status and depression studied (S. A. Stansfeld, J. Head, M. G. Marmot 1997). There are other multiple studies those studied the relationship of social class and depression. Jain and Aras (2007) in a study founded the relationship of poor socio-economic status and depression. Moreover, Mike (2006) discussed in detail the relationship of social class with depression. In a recent study the relationship of quality of life and depression specially with reference to adolescence discussed (somrongthong, Wongchaes, Loasee 2013) In another study in Indian slums it was studied that how do

depression along with factor contributes into anti social trends ( Ramnath et al 2014). The relationship of low socio economic class and depression also reported in another study (V Lorant et al 2003) (Jennifer et al 2001) determined the cluster of factors those to them are responsible for the social class relation with depression.

There are still a few debates there about depression. Roy (1979) grouped depression into three groups whereas (George and Tirril 1978) are prepared to answer questions regarding their work on depression.

Such importance of the topic of depression in clinical psychological literature specially with reference to social class relationship with depression were the main purpose of present study in order to study etic aspects in the study of depression in third largest urban population of Pakistan, the city of Faisalabad.

## II. METHOD AND PROCEDURE

Four Representative areas of slums and high class localities selected in the city of Faisalabad and total number of 120 adults and adolescents not less than 13 years of age volunteer participants 15 each from 8 selected localities irrespective of gender individually tested in the present study on 21 verbal questions of Beck Depression Inventory (BDI-11) by Aaron, Robert and Gregory in (Aaron et al 1996) to assess and not to diagnose the existence of the presence of symptoms of depression among the participants because of its easy administration within 5 to 10 minutes.

## III. RESULTS

The minimal and mild depression tested among normal subjects and both categories found, percentages reveal both among participants belonging to slums more as compared with high class localities, whereas the gender based comparison revealed the presence of the inclination of high class women to score more as compared with the women belonging to slums.

## IV. CONCLUSION

The study support the presence of etic findings in case of the study conducted in Faisalabad, supporting thereby the use of international mental health classifications like DSM and ICD locally.

## REFERENCES

- [1] Aaron T. Beck, Robert A. Steer, Roberta Ball & William F. Ranieri "Comparison of Beck Depression Inventories-IA and-II in Psychiatric Outpatients" *Journal of Personality Assessment* Volume 67, Issue 3, 1996
- [2] Craig A. Anderson and Lynn H. Arnoult (1985). "Attributional Style and Everyday Problems in Living: Depression, Loneliness, and Shyness. *Social Cognition*." Vol. 3, Special Issue on Depression, pp. 16-35.
- [3] Craig A. Anderson 'Attributional Style, Depression, and Loneliness: A Cross-Cultural Comparison of American and Chinese Students' *Personality and Social Psychology Bulletin* April 1999 vol. 25 no. 4 482-499
- [4] George W. Brown, Tirril Harris, "Social origins of depression: a reply" *Psychological Medicine / Volume 8 / Issue 04 / November 1978*, pp 577-588
- [5] JENNIFER E. B. RITSHER, VIRGINIA WARNER, JEFFREY G. JOHNSON, BRUCE P. DOHRENWEND, "Inter-generational longitudinal study of social class and depression: a test of social causation and social selection models" *The British Journal of Psychiatry* (2001) 178: s84-s90
- [6] Jain RK, Aras RY. "Depression in geriatric population in urban slums of Mumbai." *Indian J Public Health*. 2007 Apr-Jun;51(2):112-3.
- [7] MIKE DAVIS "Planet of Slums" published online: 26 APR 2006 DOI: 10.1111/j.1540-5842.2006.00797.x
- [8] N. Nisar, N. Billoo, A. A. Gadit, 2014, "Prevalence of Depression and the associated Risks Factors among Adult Women in a Fishing Community" *JPMA, Journal of Pakistan Medical Association* 54:51
- [9] Professor Dr. Ahsana Dar: "Depression and its Control" Professor Salimuzzaman Siddique Auditorium , International Centre for Chemical and Biological Sciences Karachi University.
- [10] Ramnath Subbaraman , Laura Nolan, Tejal Shitole, Kiran Sawant, Shrutika Shitole, Kunal Sood, Mahesh Nanarkar, Jess Ghannam, Theresa S. Betancourt, David E. Bloom, Anita Patil-Deshmukha, "The psychological toll of slum living in Mumbai, India: A mixed methods study" *Social Science & Medicine* Volume 119, October 2014, Pages 155–169
- [11] Roy A, "Are there different types of neurotic depression?" *British Journal of Medical Psychology*. 1979 Jun;52(2):147-50
- [12] Rozia Jalaluddin, Shanila Jalaluddin, "Factors Influencing Mental Health Policy Process in Pakistan" *Journal of Nursing* Vol 1 (01): 39-43
- [13] V. Lorant, D. Deliège, W. Eaton, A. Robert, P. Philippot and M. Ansseau, "Socioeconomic Inequalities in Depression: A Meta-Analysis" *American Journal of Epidemiology*. (2003) 157 (2): 98-112.
- [14] Salmans, Sandra (1997). *Depression: Questions You Have – Answers You Need*. People's Medical Society.
- [15] Saima Zainab, Zafar Fatmi, Ambreen Kazi , March 2012, "Risk factors for depression among married women belonging to higher and lower socioeconomic status in Karachi, Pakistan" *JPMA, Journal of Pakistan Medical Association*
- [16] S. A. Stansfeld, J. Head, M. G. Marmot , "Explaining social class differences in depression and well-being" *Social Psychiatry and Psychiatric Epidemiology* December 1997, Volume 33, Issue 1, pp 1-9
- [17] Somrongthong R, Wongchalee S, Laosee O. "Depression among adolescents: a study in a Bangkok slum community." *Scand J Caring Sci*. 2013 Jun;27(2):327-34. doi: 10.1111/j.1471-6712.2012.01037.x. Epub 2012 Jul 15.

## AUTHORS

**First Author** – Dr. Naveed Shibli

**Second Author** – Hina Majid

**Third Author** – Amana Zafar Ahsan

**Fourth Author** – Amana Khalil

**Fifth Author** – Moon Abdul Rauf

# A Study on MSMEs'- Role in Propelling Economic Development of India & a Discussion on current HR issues in MSMEs' in India

Mrs Ashu Katyal \*, Mrs Betsy Xaviour \*\*

\* Assistant Professor-Management Dept., Faculty Of Hospitality Management & Catering Technology(FHMCT), M S Ramaiah University Of Applied Sciences , Bangalore

**Abstract-** MSME (Micro, Small and Medium Enterprises) are the heart of Indian Industry. Their contribution especially to a developing country like India is very valuable. They not only contribute in generating employment but also encourage low skilled level workers to start as entrepreneur level in rural areas. As data given by Economic Times in June 2013, they employ close to 40% of India's workforce. Their main boost is given to Indian Manufacturing industry which is around 45% and export oriented units which are close to 40%. The MSME sector in India is highly heterogeneous in terms of the size of the enterprises, variety of products and services, and levels of technology. It helps in industrialization of rural and backward areas, reducing regional imbalances and assuring more equitable distribution of national income and wealth. MSME complement large industries as ancillary units and contribute enormously to the socioeconomic development of the country. MSME manufacture more than 6,000 products ranging from traditional to high tech items. Even though contributing so much in industrial growth, MSME internal operation is still far behind from the other developed industries. So focus of my paper is the HR operations and systems an MSME should have, a minimalist approach mandates that any business, no matter the scale of operations but should have a clear talent philosophy guiding vital talent management processes like talent acquisition, assessment, development, retention and leadership. Apart from that there are so many other challenges like credit to MSME, access to markets, lack of technological knowledge, lack of proper infrastructure etc. To overcome these challenges govt. Of India also taken some steps like MSME Development Act, 2006 has been enacted to facilitate these units first time and towards fulfilling the Credit needs of MSME various schemes have been introduced like "Credit Linked Capital Subsidy Scheme" (CLCSS). Looking forward for future growth MSME should grab opportunities through Globalization and be a messenger for Indian industrial growth as well as cultural heritage.

**Index Terms-** MSMEs, Economic Development, GDP, Employment, talent management, credit schemes, MSME Act.

## I. INTRODUCTION

Micro, Small and Medium Enterprises (MSME) sector has emerged as a highly vibrant and dynamic sector of the Indian economy over the last five decades. Micro, Small and Medium Enterprises (MSME) contribute nearly 8 percent of the

country's GDP, 45 percent of the manufacturing output and 40 percent of the exports. They provide the largest share of employment after agriculture. MSME not only play crucial role in providing large employment opportunities at comparatively lower capital cost than large industries but also help in industrialization of rural & backward areas, thereby, reducing regional imbalances, assuring more equitable distribution of national income and wealth. MSME are complementary to large industries as ancillary units and this sector contributes enormously to the socio-economic development of the country.

They are the nurseries for entrepreneurship and innovation. They are widely dispersed across the country and produce a diverse range of products and services to meet the needs of the local markets, the global market and the national and international value chains. Entrepreneurship is indispensable to accelerate the industrial growth. Small and Medium enterprises are an effective means for the development of entrepreneurship. This sector is a only solution to the problems of poverty, insecurity, unemployment, over population he modern world. This article attempted at highlighting the significance MSME in economic development of India.

At present firms are acknowledging the efficient management of human resources as a critical factor in their success or failure (e.g., Huselid, Jackson, & Schuler,1997; Paauwe, 2004; Schuler & Jackson, 1999). Does this equally apply to MSME?

As MSME focus more on running the business on a day-to-day basis, they find less time to manage the HR processes which is perceived as non-priority. MSME do not feel like revamping existing organizational structure, especially when they know that the status quo is delivering the output. Competitiveness of MSME can be enhanced through better human resource (HR) practices of recruitment, selection, training and compensation. Indian MSME need to reduce overall cost of products to remain competitive with Chinese manufacturers and exporters. Apart from other functional areas such as production, finance, marketing, inventory and logistics, MSME also need to focus on implementing best HR practices.

## II. DEFINITIONS OF MICRO, SMALL & MEDIUM ENTERPRISES

As MSME focus more on running the business on a day-to-day basis, they find less time to manage the HR processes which is perceived as non-priority. MSME do not feel like revamping

existing organizational structure, especially when they know that the status quo is delivering the output. Competitiveness of MSME can be enhanced through better human resource (HR) practices of recruitment, selection, training and compensation. Indian MSME need to reduce overall cost of products to remain

competitive with Chinese manufacturers and exporters. Apart from other functional areas such as production, finance, marketing, inventory and logistics, MSME also need to focus on implementing best HR practices.

**TABLE 1: MICRO, SMALL AND MEDIUM ENTERPRISE**

Nature of the Enterprise	Micro Enterprise	Small Enterprise	Medium Enterprise
Manufacturing Sector	Investment in initial Fixed assets (plant and Machinery, which Excludes land & Building) does not Exceed Rs. 2.5 million	Investment in initial Fixed assets (plant And machinery, Which excludes land & building) more Than Rs. 2.5 million But does not exceed Rs. 50 million	Investment in initial Fixed assets (plant And machinery, Which excludes land & building) more Than Rs.50 million But does not exceed Rs. 100 million
Service sector	Investment in Equipment does not Exceed Rs. 1.0 Million	Investment in Equipment is more Than Rs. 1.0 million But does not exceed Rs. 20 million	Investment in Equipment more than Rs. 20 million but Does not exceed Rs. 50 million

(Source: Tabulated by Author)

**MSME AS GROWTH DRIVER OF INDIAN ECONOMY**

In India, 95 percent of industrial units (3.4 million) are in small-scale sector with a 40 percent value addition in the manufacturing sector. Enterprises of this type provide the second highest employment level after agriculture and account for the 40 percent of industrial production. These units contribute 35

percent to India’s exports. In this setting, Indian msmeare fundamentally important to the Indian economic system. Their potential to generate employment, bolster exports and bring flexibility into India’s business environment deserves close attention from India’s policy makers and research scholars.

**TABLE 2: GROWTH AND PERFORMANCE OF MSMEs IN INDIA : MSME UNITS, INVESTMENT, PRODUCTION, EMPLOYMENT AND EXPORTS**

YEAR	Total msmes (Lakh)	Fixed Investment (in Rs Cr)	Production (Rs in Cr.)	Employment (Lakhs Persons)	Exports (Rs in Cr.)
2005-2006	123.42	188113	497842	294.91	150242
2006-2007	261.12 (111.57)	500758 (166.20)	709398 (42.49)	595.66 (101.98)	182538 (21.50)
2007-2008	272.79 (4.47)	558190 (11.47)	790759 (11.47)	626.34 (5.15)	202017 (10.67.)
2008 - 2009	285.1 (4.53)	621753 (11.39)	880805 (11.39)	659.35 (5.27)	NA
2009 - 2010 *	298.0 (4.53)	693835 (11.59)	982919 (11.59)	695.38 (5.46)	NA
2010 - 2011 #	311.5 (4.52)	773487 (11.48)	1095758 (11.48)	732.17 (5.29)	NA
2011 - 2012 #	447.7 (43.7)	117699 (52.16)	1834372 (67.40)	1012.59 (38.24)	NA

The figures in brackets ( ) show the percentage growth over the previous year.

\* Provisional

# Projected

Source: Ministry of Micro, Small and Medium Enterprises, Annual Reports 2011-12 and 2012-13

### III. PRODUCT OFFERINGS IN MSME

SSI units produce an amazing variety and type of products. Over 7500 products are known to be manufactured in this sector. Even in a particular product, there would exist a wide range of qualities or specifications catering to different market segments, particularly in consumer/household products. Small Scale sector has emerged as a major supplier of mass consumption like:

#### FOOD PRODUCTS

- Chemical & Chemical Products
- Basic Metal Industries
- Metal Products
- Electrical Machinery & Parts
- Rubber & Plastic Products
- Machinery & Parts Except Electrical goods etc.

### IV. LITERATURE REVIEW

Managing HR presents significant challenges to any firm, but smes face unique challenges that stem largely from their size

(Greening et al., 1996), with regard to the attraction and retention of employees which is clearly linked with the ability to Offer a competitive benefits package (Williams and Dreher, 1992). While larger Organizations face the challenge of retaining and developing talent within their Organizations, smes face the more basic challenge of hiring the right kind of people For themselves. If smes can achieve the right mix of effective leadership, innovative Management, decision-making autonomy, growth opportunity and financial Attractiveness, they would be able to create the much sought after unique employer Brand, enabling them to attract the right talent to deliver on their promises. Leadership, management and performance orientation form the core of the HR Challenges faced by smes, and it is critical that organizations tackle this.4 Because Of smaller workforces, many specialized HR activities are infrequently performed in Smes (Cook, 1999).Sunder and Kumar (2012) have concluded that the absence of HR policy is the root cause of most of the anomalies in the HR spectrum. They found that the mechanism for fixation of compensation for employees is widely varied.

Research shows that managers of small firms lack training in formal personnel management practices and they do not



consider the use of generally accepted HRM practices as essential for improving productivity (mcevoy, 1984; and Amba-Rao and Pendse, 1985). A majority of the published research investigating HRM issues in small businesses is conceptual and has concentrated on diverse HRM topics. Flairfield-Sonn (1987) developed a strategic process model to guide the establishment of small business training and development programs. A study of 347 small midwestern firms identified selection and retention of quality workforce as the most important HRM issue for small firms (Hornsby and Kuratko, 1990). Deshpande and Golhar (1994) observed that many personnel practices of small and large firms are similar. According to Longenecker et al. (1994), HR activities often become the responsibility of general managers in smes.

The lack of 'in place and streamlined' HR functions in these organizations come as a weakness when all the efforts invested in building a team become fruitless because of high attrition rates. There can be several reasons to this such as dissatisfaction with pay, HR policies and practices, lack of hygiene factors, employee loyalty issues, and the like

A competent workforce is perhaps the most important asset for any organisation. Thus it is in the interest of any company irrespective of its size to positively focus on human resource (HR) development & management. However, it is rather sad that the HR activities are often neglected by many Indian MSME. As per a survey conducted by the Confederation of Indian Industries (CII), around 80% from the small enterprises and about 20% of the medium enterprises respondents indicated having no formal HR department. The Indian economy is now the second fastest growing economy of the world. As per the Ministry of Finance, the GDP of India stood at 8.8% in the first quarter of 2010-11 (the overall growth of GDP in 2009-10 was 7.2%); overall growth in the Index of Industrial Production (IIP) was recorded at 13.8% during July 2010 as opposed to 7.2% in July 2009.

Many forms of technological change are accompanied by changes in skill requirements. This is particularly true of the changes associated with the adoption of the new advanced technologies that are being implemented in the manufacturing sector (Doms, Dunne, and Troske, 1997). The contradiction of managing opposing forces, is caused by the attempt to apply a more flexible approach to human resources, and not just apply more flexibility to the individual within the company, and this flexibility seems to be based on both employee as well as employers interests. There is no consensus among researchers regarding the role of HRM in small-firm success (Deshpande and Golhar, 1994). HRM practices may be a leading cause of small business failures (mcevoy, 1984). Inadequate and inefficient HRM in MSME may result in low productivity and high

dissatisfaction and turnover among the staff (Mathis and Jackson, 1991).

## V. RESEARCH OBJECTIVES

1. Identifying the current status of HR operations in MSME.
2. Find out the contribution of msme in economic development of the country.
3. Challenges confronting by MSME.
4. Finding out ways to overcome the challenges in MSME and issues related to HRM.

## SCOPE AND METHODOLOGY OF THE STUDY

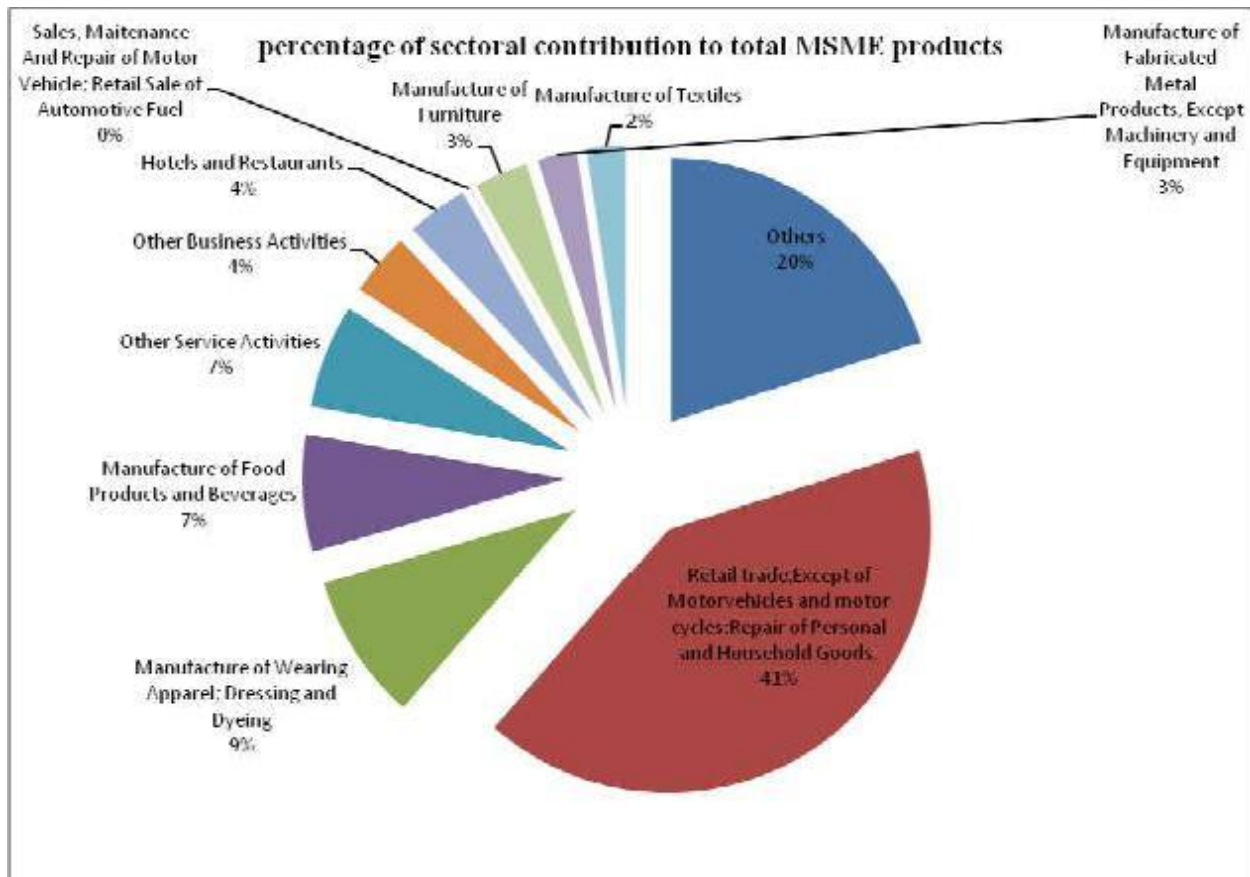
The scope of the present study has been confined to the contributions made by the MSME to the Indian economy and how HR department is making a contribution to the growth and sustainability of MSME. The data for the present study have been collected from various Secondary sources especially from the annual report published by Ministry of Micro, Small And Medium Enterprises for various years.

## ARE MSME THE BACKBONE OF INDIAN ECONOMY?

MSME have great role in the balanced development of the economy. MSME sector presently employs over 100 million people over 44 million units and MSME accounts for 9% of the country's GDP. Annual report of Ministry of MSME states that the sector accounts for about 45% of total export of the country. MSME sectors produce more than 6000 quality products. MSME sector, thus, shows greater opportunity for expansion and diversify its activities in various sectors. It is estimated that there are 1.6 million registered MSME in India and major portion of MSME working in India are not registered. MSME are dominated by micro enterprises with 94.9 percent share followed by small enterprises with 4.9 percent of share. These enterprises deployed throughout India by operating 55 percentages in rural India and rest operating in semi-urban and urban region of India. And hence the MSME contribute a commendable portion to the balanced growth of Indian economy. On the activity basis, if we are exploring, it can be seen that 67.1 percent of total registered units are manufacturing units, 16.8 percent of total registered units are service units and 16.1 percent units of total registered units are repair and maintenance units. From the diagram given below we can get some clearer picture about the distribution of 6000 units of MSME into their respective sectors.

GRAPH1

SOURCE: ANNUAL REPORT FY 12, MINISTRY OF MICRO SMALL AND MEDIUM ENTERPRISES.



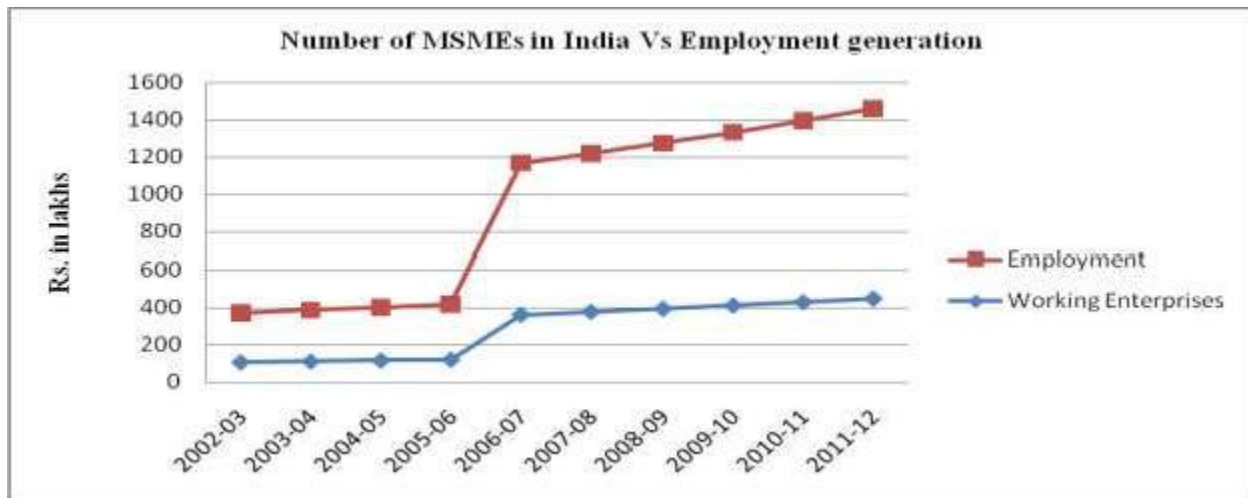
### GENERATING EMPLOYMENT OPPORTUNITIES

Employment opportunities are one among the important variables of economic growth of a country. Now a days, the Arab world is facing the problems created by its unemployed unrest people. No economy can economically sustain unless and until it provide lively hood to its local people. Traditionally the MSME are labour intensive and alleviating unemployment problems to a great extent. Indian MSME sector is the second largest employment generator next to agricultural sector. It employs about 101 million people and creates 4 million employment opportunities a year.

The number of MSME has been increasing steadily. In 1991 there were only 67.87 lakh units, but it increased multi folded by 2011- 2012. This change might be the result of conducive policy environment during the liberalization era. As MSME, generally are labour intensive, employment generation always follows the increase in the number of units. It seems to be a boon to rural people as MSME do not demand highly skilled employees and semi skilled and even unskilled people can be employed in such units.

**GRAPH 2**

**SOURCE: ANNUAL REPORT FY 2012-13, MINISTRY OF MICRO, SMALL AND MEDIUM ENTERPRISES, GOVT. OF INDIA.**



*Note: data up to FY 06 is for small scale industries and subsequently to which data is for MSME.*

The above plotted graph clearly shows that increase in number of units of MSME always followed by an increase in the employment generation.

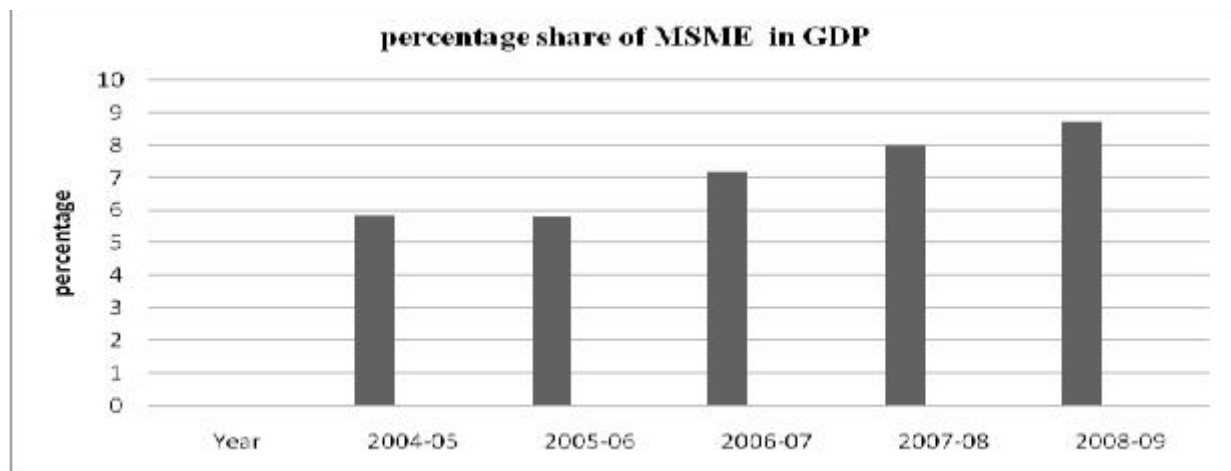
**MAJOR CONTRIBUTOR TO GDP**

MSME sector is a major contributor to nation’s GDP. News about GDP we listen to is alarming now a days. In the fourth quarter of 2012-2013 (January to March 2013) witnessed a slide of GDP to 4.8 percent. MSME sector constitutes an inevitable portion of GDP and hence it needs attention of the policy makers.

The statistics show that the contribution of MSME to GDP is ever increasing. The below given graph delineates the percentage share of MSME in the nation’s GDP over the years. It has managed to increase from 5.8 percent 2004-05 to 8.72 percent in 2008-09

**GRAPH 3**

**SOURCE: ANNUAL REPORT FY 12-13, MINISTRY OF MICRO, SMALL AND MEDIUM ENTERPRISES, GOVT. OF INDIA.**



*Note: Data for the period up to 2005-06 is for SSI and subsequent to 2005-06 is for MSME.*

**CONTRIBUTION TO INDUSTRIAL PRODUCTION AND EXPORT**

MSME are, at present, operating in wide variety of sectors such as manufacturing, trade and services and there by constitute a formidable component of country’s industrial production.

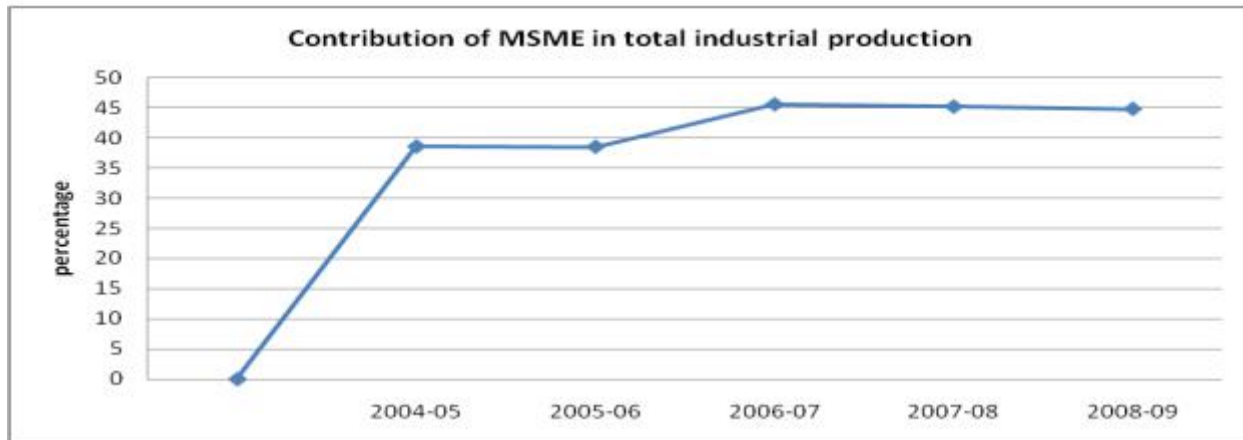
Over the year MSME reached at a level on the optimum utilization of available domestic resources and produces quality products and services. The sector contributes much to the industrial growth of the country. The sector account for more than 90 of the percent Industrial units in India and it has been

increasing impressively for last many years. MSME had an impact on various issues of the economy such as industrial progress, entrepreneurship, job creation, economic empowerment

etc. MSME made possible an inclusive and balanced growth. Around 50% MSME are owned by rural people and hence increases the standard of living of people.

**GRAPH 4**

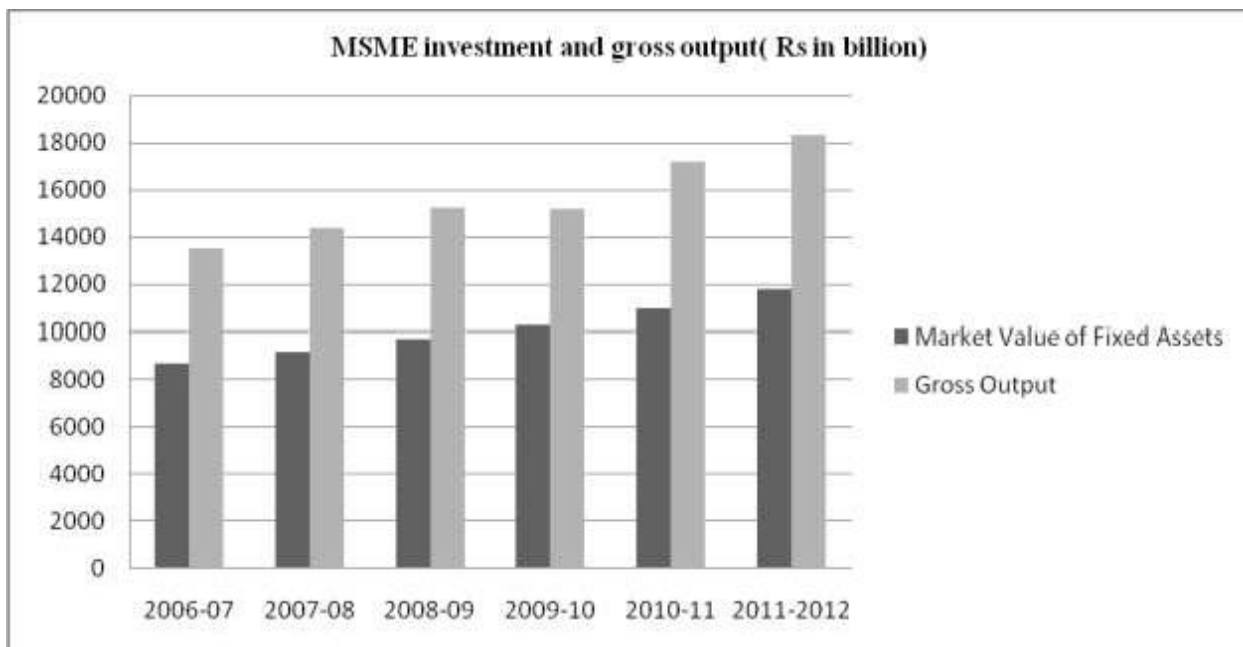
**SOURCE: ANNUAL REPORT FY 12, MINISTRY OF MICRO, SMALL AND MEDIUM ENTERPRISES, GOVT. OF INDIA.**



*Note: Data for the period up to 2005-06 is for SSI and subsequent to 2005-06 is for MSME.*

As per the MSME Annual Report of FY 12 published by Ministry of Micro, Small and Medium Enterprises MSME contribute 45% of the total manufacturing output. MSME experiencing a significant increase in investment flows. The fixed investment in MSME is ever increasing. Graph above shows the contribution of MSME to the total industrial production. It is very clear that around 50 percent of total

industrial production is constituted by MSME. The total production of MSME sector is showing increasing trend. We can read it from the graph given below. The graph depicts that investment in fixed asset has increased from Rs 8685.44 billion in 2006 - 07 to Rs 11769.39 billion in 2011- 12 and total production shows an increase from Rs 13513.83billion in 2006-07 to Rs 18343.32 million in 2011-12.



**Graph 5**

*Source: Annual report FY 2012-13, Ministry of Micro, Small and Medium Enterprises, Govt. Of India.*

When we talk about country's export, it is noticeable that MSME contribute 40 percent of the total export. The current account deficit (CAD) have been subjected to hot debate during the third and fourth quarter of 2012-13 financial year. The alarming decline in the CAD can be, to a great extent, arrested by promoting the MSME sector though CAD is influenced by many other variables like economic downturn. The data show that the MSME always showing an increasing trend in the contribution to the total export of the country. It has an increase from Rs. 71244 crores in 2001-02 to Rs. 202017 crores in 2007-08.

## HR ISSUES IN MSME

### MSME: MAJOR HR CHALLENGES

Main problems of small enterprises related to HR practices are attracting talent, motivating Employees and retaining key employees as small enterprises lack resources to advertise for Positions, pay salaries in the range of large organizations and train employees (Singh & Vohra, 2005). It seems to be the case that MSME have had the view, that HR practices is Unresponsive or not tailored to their needs, and it is considered too costly an activity to carry For a MSME. MSME are generally started by a single entrepreneur or a small group of people, And are often managed by owner- managers (Ritchie, 1993). Their organization structure is Mostly flat.

The survey was conducted on 524 MSME of NCR (National Capital Region) ranging from manufacturing, ancillaries, sales/services and hospitality industries with 10 to 100 employees strength, and the findings are not much surprising. Broadly, HR function stands nowhere in this sector. 70% of the organizations have no formal HR department or exclusive person for this function. Payroll/attendance/statutory compliance are either completely outsourced or part-timers perform record maintenance functions, or the owner himself controls this function.

Most previous studies have identified or examined different types of problems based on the size, age, and/or growth rate of the firm. In which "people" or "human resource" (HR) problems facing firms in various stages that we intend to examine. The human resource "department" for a small business is usually not more than one person—and often only one person who wears many hats. While general people/HRM problems have been identified few studies have focused on specific MSME HRM problems or issues. Consequently, Firms of different sizes do apparently have different HRM problems and practices but five specific HRM areas must be examined: job analysis/job description, recruiting/selection compensation/benefits, retention, job security, training and performance appraisal. It also specifies some strategies to overcome these issues and coming up with Innovative HR strategies. It is therefore important that not only the customers and suppliers, MSME today also need to collaborate closely with their own employees, in order to increase the organizational efficiencies.

## INNOVATIVE HR STRATEGIES

### RECRUITMENT:

In the today's liberalized and globalised economy, the nourishing of any organization depends on the integral growth of employees. Talent crunch can impact any organization's

bottom line and growth. MSME are struggling to fill talent gap, find skilled workers especially at workmen level and middle level positions. Identifying right candidate for a right job with right skill, and aligning their business for getting the quality cost scale balance right, stands as a huge challenge to any MSME's. One more important challenge is to, how they can retain their key talent.

Research has shown that negative outcomes result from an overemphasis on the business Owner's personal values, attitudes and beliefs. Personal values can lead to costly recruitment Mistakes and to discrimination (whether you know it or not) and this can result in legal problems That could terminate the business.

### How to do it (Recruitment in MSME)

- Decide on the skills, knowledge and experience that the business needs to fill a specific job Role.
- Produce a 'job description' and a person specification that outlines the skills and experience needed for the role.
- Check that the job description does not exclude anyone from applying because of racial origin, religious belief, gender, sexual orientation, age or disability.
- Adapt your methods to allow (and encourage) disabled people to apply.
- Avoid 'word of mouth' recruitment processes. Consider a range of advertising methods e.g.: Jobcentre, national, local or 'community' newspapers; schools, colleges or universities.
- State that you welcome applications from all sections of the community.

### RETENTION:

As mentioned earlier, the major challenge for MSME is to retain their talent pool because of lack of competitive salary. The job of the HR personnel increases when the present employees are leaving the organization at the time of crisis. The HR personnel should try to retain the present employees by following some of the efficient strategies which include

- Offering a competitive benefits package that fits the employee needs and expectations
- Using contests and incentives to help keeping workers motivated and feeling rewarded.
- Creating open communication between employees and management develops trust in the employees.
- Fostering employee development and getting managers involved in this activity will give employees a visibility of their own career path.
- The managers need to spend time in coaching employees, helping good performers move to new positions and minimizing poor performance.
- Conduct "Retention interviews", in addition to performing "exit interviews" to learn why employees are leaving, consider asking longer-tenured employees as to what made them to stick to the organization.

As per the Wall Street Journal (2012). In today's competitive world, "MSME must recruit and select the best talent

where they have openings and upgrade talent in areas where it will advantage the business. It is necessary for the MSME to take a step back and evaluate workforce plans, as well as talent acquisition processes and enabling technology and determine a strategy that works for the organization in the retention process”.

#### **MOTIVATION:**

The motivation of employees is one of the key factors that affect the progress of an industry. In MSME the lack of employees’ motivation is a major management deficiency. Keeping employees satisfied on the job is another important human resource activity in the MSME’s. As financial benefits are not competitive as those of larger and more established firms, the human resource manager of the small firm needs to ensure that its employees remain satisfied on the job. For MSME the heart of the motivation process lies in ensuring and maintaining smooth and harmonious working and personal relationships among its employees. Respectful language at work place provides support and encouragement and enables employees to develop good working relationships. Mentoring adds up in the strengthening of harmony in the MSME.

#### **JOB SECURITY:**

Any employee prefers to do a job which is secure for him. The MSME’s should always try to provide the job security for the employees so as to reduce the retention rates. Employees always want to have a „secured job”. Here is how the HR department can add value and definitely make people love the job they do with a psychological satisfaction. The strategies in which HR can create the „Best Job” are as follows:

- HR Manager can create an environment which gives the employees an opportunity to give their 100 percent.
- Think of ways which makes the job more exciting.
- The HR Manager must recognize the employee’s true passions - concepts like knowledge or technology, job functions or skills.
- HR must make a record of tasks where an employee did something best at the workplace.
- HR Manager must make a note of the projects where the employee really enjoyed.
- List down all the accomplishments of the employee and create a mentoring program where employees can talk to people whose advice they value, people who have

worked with them, and who have watched them in action.

- Finally, if an employee is already doing something he/she loves, HR Manager should make it rewarding by aligning them to the goals of the organization, contributing more than what is expected, and giving them every opportunity to learn.

#### **EMPOWERMENT:**

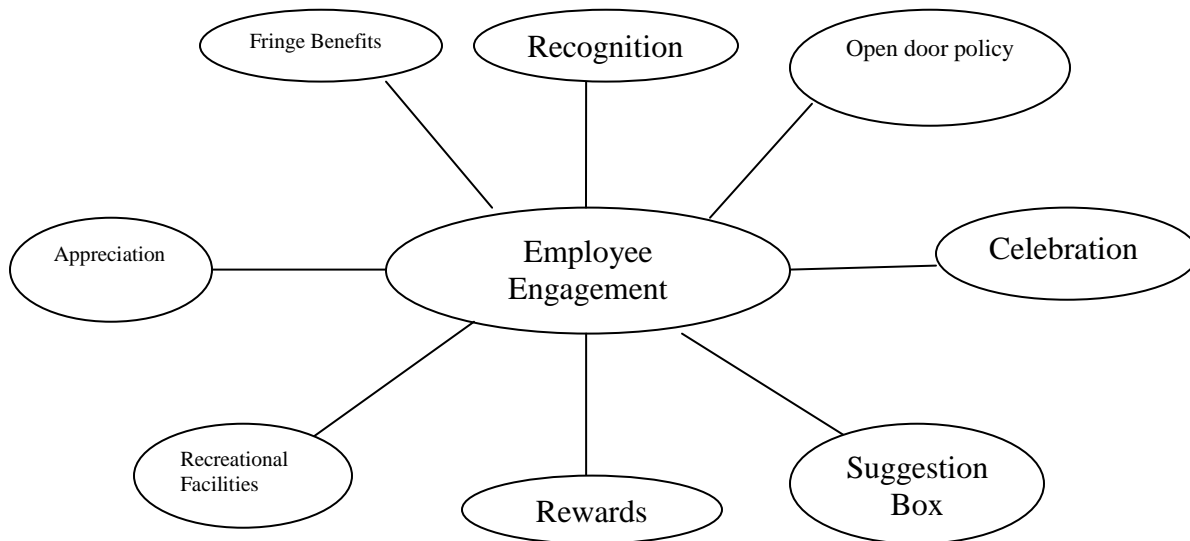
Empowered employees feel they have the ability to make decisions and put them into action. Empowered personnel are expected to act, at least in some small way, like owners of the company rather than just employees. One of the major tasks faced by HR personnel is empowering the employees with certain decision making powers and authority. Every employee feels that he should have certain decision making powers with him to do a particular job. The empowerment of employees can happen when the clear definition of the values and mission of the company is explained and imbibed in them. Secondly, company must help employees in acquiring the relevant skills. Thirdly, employees must be supported in their decision-making, and not criticized or do the constructive criticism, when they try to do something extraordinary. And lastly workers need to be recognized for their efforts. Managers have to understand that empowerment is an important strategic tool. In order to reap the benefits, managers should implement the above practices. Otherwise, talk about empowerment will be perceived as “lip service” by employees, and have no positive effect.

#### **EMPLOYEE ENGAGEMENT:**

Small and medium enterprises (MSME) are worst affected during challenging economic era when resources are scarce, competition is intense and customers are more demanding than ever. Thus for MSME it is even important to have emotionally engaged and passionate employees. They play a critical role in driving innovation and propelling the organization forward. Emotionally engaged employees are generally more willing to recommend the organization to others and commit time and effort to help the organization succeed (Gupta, 2009) In MSME sector, to build a great workplace and increase employee engagement, there are a few innovative practices which can be adopted to leverage the advantage of the companies as explained in the figure below (Caccamese, 2012).



Figure 1



Only 8% of the industries have a formal HR person taking care of HR administration and employee relations. In 91% of the industries, there is no empowerment to this function. All HR/Employee relations policies are owner-driven.

#### WORKFORCE DIVERSITY:

In the highly globalized era, the more interaction among people from diverse cultures, beliefs, and backgrounds than ever before is required. People no longer live and work in an insular marketplace; they are now part of a worldwide economy with competition coming from nearly every continent (Byrne, 2011). Cultural diversity training programs must also be set for all the employees and managers or supervisors concerned. This training will help them be aware of the different cultures and beliefs for a diverse workforce existing in company. In a like manner, a seminar or workshop on team building should be frequently conducted and implemented for cohesiveness and unity amidst the diversity of the work. The HR personnel should educate his employees the benefits they will get by working with diverse work force.

#### TRAINING AND DEVELOPMENT

Training appears to be largely limited to product sales and service training. There is no evidence of any technical or behavioral training that can help augment the skill level of employees in various functions. As the data shows:

- Only 32 % companies offer both on the Job training & Off the job training which is very much required for technical jobs
- 74% of companies are not having development program which gives employees an opportunity for developing knowledge, skills and attitude for the job as well as for company.

#### PERFORMANCE MANAGEMENT

The company has a practice of appraising employees annually. However, the format appears to be different for various divisions. In the various interactions had so far, no evidence of such a concerted performance strategy has been found. Only 47% of companies are having formal performance management system.

#### COMPENSATION & BENEFITS

The company has a practice of following timely payments and provides various employee benefits. However, the manner in which payroll is administered vis-à-vis permanent and temporary employees is not very clear. In most interactions, the policy of granting incentives across various divisions appears to be quite arbitrary leading to employee dissatisfaction. At this stage the linkage between performance and incentive appears to be clear for some divisions but the way in which the incentive scheme/program is administered is not transparent. Majority of Companies (66%) are not following manpower planning which is very much helpful in keeping company lean and thin in today's recession like situation.

#### VI. CONCLUSION

Human Resource is one of the most essential growth indicators for organizations today. There is a lack of formalization in the management of HR issues. This is in contrast to multinational companies operating in India who have adopted structured and formalized HR systems. As the studies showing very less msme have formal HR dept and in new small business units owners only handling the HR practices. So with skill training there should be some procedure to provide basic HR functional training to owners so that initially they can handle HR Functions and understand the importance of HR in organizations. Later on after small units become profit oriented units, they can have formal HR dept to run each HR function systematically.

Second option for msme to outsource their HR functions to some outside authority, which can happen after establishing it a profitable unit. So The business owners or HR managers should ensure good HR practices in their organizations to remain competitive.

#### REFERENCES

- [1] Madhan, P. M. (2012, February 11). SME's as Growth Driver of Indian Economy: Strategic HR Issues and Perspectives. Business Strategies and India's Economic Growth Conference (RBCON - 2012).
- [2] Contribution made by msme at heart of Indian economy. (2013, August 24). New Indian Express .
- [3] India's MSME sector growing faster than overall GDP: Michel Botzung. (2013, December 30). Business Standard.
- [4] Recommendations of the Inter-Ministerial Committee for accelerating Manufacturing in Micro, Small & Medium Enterprises Sector. (2013, september). Retrieved from msme.gov.in: <http://msme.gov.in/Accelerating%20Manufacturing%20in%20the%20MSME%20Sector.pdf>
- [5] Agarwal, H. (2011). HR Issues in Micro, small and Medium Enterprises. International Journal of Research in Finance & Marketing, 1(3), 232-246.
- [6] Data.gov.in. (n.d.). Retrieved from [www.data.gov.in: http://data.gov.in/dataset-group-name/fourth-all-india-census-msme-registered-sector-0](http://data.gov.in/dataset-group-name/fourth-all-india-census-msme-registered-sector-0)
- [7] DR.P.Uma. (2013). Role of SMES in Economic Development of India. Asia Pacific Journal of Marketing & Management Review, 2(6).
- [8] Garg, B. (2014, February). Role of human resource in MSME in india Researchjournal's Journal of Entrepreneurship. Researchjournal's Journal of Entrepreneurship, 2(2).
- [9] Kishore, K., Majumbar, M., & Kiran, V. (2012, July\_Aug). Innovative HR Strategies for smes. IOSR Journal of Business and Management, 2(6), 1-8.
- [10] Naser, A. V. (2013, July). A critical evaluation of the Contributions made by the Micro, Small and medium Enterprises in Indian Economy. International Journal of Marketing, Financial Services and Management Research, 2(7).
- [11] Rajan, A. K., & Pahal, S. (n.d.). Human Resource Outsourcing in SMES - An Exploration of Critical Issues. International Journal of Marketing, Financial Services & Management Research, 1(6).
- [12] Small and Medium Business Development Chamber of India. (n.d.). Retrieved from [www.smechamberofindia.com: http://www.smechamberofindia.com/challenges\\_to\\_sme\\_sector.aspx](http://www.smechamberofindia.com/challenges_to_sme_sector.aspx)
- [13] Sunder, K., & Kumar, A. P. (2012, December). HUMAN RESOURCES MANAGEMENT PRACTICES IN SMALL AND MEDIUM INDUSTRIES – AN INDIAN EXPERIENCE . Spectrum: A Journal of Multidisciplinary Research, 1(9).
- [14] Varghese, S. (2010, September). HR systems & msme: How many is too many? Humancapital, 54-57.
- [15] [www.dcmsme.gov.in](http://www.dcmsme.gov.in). (n.d.). Retrieved from Govt. Of India Development Commissioner (MSME) Ministry of Micro Small Medium Enterprises: [http://www.dcmsme.gov.in/ssiiindia/defination\\_msme.htm](http://www.dcmsme.gov.in/ssiiindia/defination_msme.htm)
- [16] [www.dnb.co.in](http://www.dnb.co.in). (n.d.). Retrieved from D&B: <https://www.dnb.co.in/Nashik2013/PDF/msmesinindia.pdf>

#### AUTHORS

**First Author** – Mrs Ashu Katyal, Assistant Professor- Management Dept. Faculty Of Hospitality Management & Catering Technology (FHMCT), M S Ramaiah University Of Applied Sciences , Bangalore, Email id- [ashu.hr@gmail.com](mailto:ashu.hr@gmail.com), Mobile: 9731938573

**Second Author** – Mrs Betsy Xaviour, Email id = [betsyxaviour07@gmail.com](mailto:betsyxaviour07@gmail.com), Mobile: 9663770967

# Effect of Cash Management on Financial Performance of Deposit Taking SACCOs in Mount Kenya Region

Njeru Mugambi Duncan<sup>1</sup>, Dr. Agnes Njeru<sup>2</sup>, Dr. Florence Member<sup>3</sup>, Ondabu Ibrahim Tirimba<sup>4</sup>

<sup>1</sup>PhD Finance Candidate, Jomo Kenyatta University of Agriculture and Technology

<sup>2</sup>Lecturer, Jomo Kenyatta University of Agriculture and Technology

<sup>3</sup>Lecturer, Jomo Kenyatta University of Agriculture and Technology

<sup>4</sup>Research Fellow and Lecturer Mount Kenya University, Hargeisa Campus

**Abstract-** This study sought to explore the effect of cash management on financial performance of deposit taking SACCOs in Mount Kenya Region. The target population was all the thirty licensed deposit taking SACCOs in Mount Kenya Region, the sampling technique employed was simple random sampling and the sample size was 92 respondents. This study adopted a descriptive survey in soliciting information on effects of liquidity management on financial performance of deposit taking SACCOs in Mount Kenya region. Primary quantitative data was collected by use of self-administered structured questionnaires. The researcher also used secondary data derived from the audited financial statement of the SACCOs and the regulator (SASRA). The data collected was analyzed, with respect to the study objectives, using both descriptive and inferential statistics. The researcher concluded that there is need to introduce cash management controls in the SACCOs, there is need to better strengthen the role of SASRA and increase its awareness, there is need to introduce credit management policy and finally increase the monitoring role of the government through its regulator in the sector since the sector plays a critical role on the achievement of vision 2030 and improved economic development of the members.

## I. INTRODUCTION

### C1.1 Background of the study

Cooperative societies are an autonomous association of persons united voluntarily to meet their common economic and social needs through jointly owned and democratically controlled enterprises, which are organized and operated under the principles of cooperatives (ICA, 2005). They are embodied in the values of self-help, honesty, openness, self-responsibility, social-responsibility, democracy, quality, equity, solidarity, mutual caring, efficiency, transparency and accountability (Okello, 2006; ICA, 2005). Generally, cooperatives are community institutions voluntarily and autonomously established and managed by the communities, and also give services for the local communities.

As Clement (2012) asserts, SACCOs have the ability and opportunity to reach clients in areas that are unattractive to banks, such as rural or poor areas (as cited in Branch, 2005). This has made SACCOs more attractive to customers, thus deeply entrenching themselves in the financial sectors of many countries (as cited in Munyiri, 2006). In Kenya, SACCOs have mobilized over Kshs.200 billion in savings, accounting for over 30% to

National Domestic Saving (Co-operative Bank of Kenya, 2010). Liquidity risk is a failure of SACCOs to honor approved loans due to inadequacy of loanable funds (Fiedler, Brown, & Moloney, 2002). Liquidity risk needs to be monitored as part of an integrated institution wide risk management process taking into account market and credit risk to ensure stability and improvement of loan portfolio in the balance sheet.

As Nyabwanga (2011) asserts, working capital management is a very important component of corporate finance because it directly affects the liquidity, profitability and growth of a business and is important to the financial health of businesses of all sizes as the amounts invested in working capital are often high in proportion to the total assets employed (as cited in Atrill, 2006). As Nyabwanga (2011) asserts, this management of short-term assets is as important as the management of long-term financial assets, since it directly contributes to the maximization of a business's profitability, liquidity and total performance. Consequently, businesses can minimize risk and improve the overall performance by understanding the role and drivers of working capital (as cited in Lamberson, 1995).

As Nyabwanga (2011) asserts, cash management is the process of planning and controlling cash flows into and out of the business, cash flows within the business, and cash balances held by a business at a point in time (as cited in Pandey, 2004). Efficient cash management involves the determination of the optimal cash to hold by considering the trade-off between the opportunity cost of holding too much cash and the trading cost of holding too little (as cited in Ross et al., 2008) and as stressed by Atrill (as cited in 2006), there is need for careful planning and monitoring of cash flows over time so as to determine the optimal cash to hold. As Nyabwanga (2011) asserts, setting up of a cash balance policy ensures prudent cash budgeting and investment of surplus cash (as cited in Kwame, 2007). This finding agree with the findings by (as cited in Kotut, 2003) who established that cash budgeting is useful in planning for shortage and surplus of cash and has an effect on the financial performance of the firms. The assertion by (Ross et al., 2008) that reducing the time cash is tied up in the operating cycle improves a business's profitability and market value furthers the significance of efficient cash management practices in improving business performance.

According to (Sambasivam, 2013), the deposit and loan portfolio in SACCOs amounts to about 34 percent of national savings and about 24 percent of outstanding domestic credit (as cited in CBK Report, 2008). It is undeniable fact that member's

loan demand is very high and incompatible compared with the availability of funds (Sambasivam, 2013). This follows that SACCOs face a risks arising from liquidity shortage and this has been a major cause of failure of many financial cooperatives (Sambasivam, 2013). SACCOs convert immediately available savings deposits into loans with longer maturities. (Nyabwaga et al., 2011) in their study on the effect of working capital management practices on financial performance contend that working capital management routines were low amongst small scale enterprises as majority had not adopted formal working capital management routines and also the study corroborates that there is a positive relationship between working capital management practices and financial performance.

Clement et al., 2012) in their study on financial practice as a determinant of growth of SACCOs wealth content that growth of SACCO wealth depended on financial stewardship, capital structure and funds allocation strategy. Both studies did not address the issue of cash management, loan repayment and investment on non-core activities which the current study tries to address. In Kenya, SACCOs do not have access to the lender of last resort, the Central Bank of Kenya. So in times of market difficulties and constrains they have nowhere to get the asset of cash. This makes them prone to the liquidity shortage, and no matter how small, can cause great damage to a savings institution (Monnie, 2009). It is against this background that a study should be carried out on effects of liquidity management and regulation on financial performance of deposit taking SACCOs in Mount Kenya Region.

The general objective of this study was to determine the effect of cash management on financial performance of deposit taking SACCOs in Mount Kenya Region.

The findings of this study will benefit, policy makers who include the management committees and the managers of the Sacco by providing information on the appropriate cash management techniques to adopt. Also the decision makers on policy in SACCO regulatory authority will benefit in ensuring SACCOs have sufficient cash management tools for their liquidity management.

This study adopted a descriptive survey design. As Hannah, (2013) asserts, research design is the arrangement of condition from collection and analysis of data in a manner that aims to combine relevance to the research purpose with economy in procedure ( as cited in Upagade and Shende, 2012). In Kenya, there are one hundred thirty five (135) registered deposit taking SACCOs, (SASRA, 2014). The target population will be licensed deposit taking SACCOs in Mount Kenya Region (SASRA, 2014). The respondents will be the Chief Executive Office, finance manager, credit Manager and SACCO Treasurer from each Deposit taking SACCO. Hence the target population will be ( $4 \times 30 = 120$ ).

## II. THEORETICAL FRAMEWORK

### 2.1 Introduction

This chapter reviews the existing literatures theories and models related to the variables used in the study, a review of past studies on the area of study.

### 2.2 Theoretical Framework

(Kotler & Gary, 2005) described theoretical framework as a collection of interrelated concepts such as in a theory to guide a research work as it determines the items for measurement and the statistical relationships being studied. A theory is a reasoned statement or group of statements, which are supported evidence meant to explain some phenomena.

#### 2.2.1 Cash Management theory

The purpose of cash management is to determine and achieve the appropriate level and structure of cash, and marketable securities, consistent with the nature of the business's operations and objectives (Brigham, 1999). As Erkki (2004) asserts, Models on cash balance management have been proposed by (as cited in (Baumol, 1952), (Archer, 1966), (Beranek, 1963), (Miller & Orr, 1966), (Pigou, 1970), (Lockyer, 1973), & (Gibbs, 1976)) among others. (as cited in William Baumol,1952) was the first person to provide a formal model of cash management. As Erkki (2004) asserts, this model applied the economic order quantity (EOQ) to cash. Brokerage fees and clerical work form order costs while foregone interest and cash out costs form the costs of holding cash. Baumol's model is however probably the simplest, most striped down and sensible model for determining the optimal cash position (as cited in Ross, 1990). (as cited in Lockyer, 1973) on the other hand modified Baumol's model to incorporate overdraft facilities. According to Lockyer's approach the total annual cash policy cost attributable to the use of overdraft facilities is given by the sum of total annual cash transfer cost, total annual overdraft cost and the total annual holding cost. As Erkki (2004) asserts, Lockyer's model is critiqued for assuming overdraft facilities, which are not automatic especially for firms with poor credit rating. The model also assumes disbursements are even over the planning period.

As Erkki (2004) asserts, the cyclical nature of cash is recognized (as cited in Archer, 1966) who reasons that apart from providing a cash balance for transactional purposes, a cash balance should be provided for precautionary purposes, especially for seasonal activities that are unpredictable. In Archer's approach, costs related to overdraft facilities and capital costs of precautionary balances are compared to determine the optimum. Archer's approach is advantageous for it recognizes the cyclical nature of net cash flows of many firms. As Erkki (2004) asserts, enhances the reasoning (as cited in Archer, 1956). According to Gibbs, the determination of optimal cash balance involves a combination of investment and financial decisions. In Gibbs approach, cases where demand for money is of a cyclical nature a combination of short and long term borrowing should be used to avoid the use of long term funds to cover peaks arising from idle cash balance, during periods of low cash demand. Gibbs contends that, the determination of the amount of buffer money to hold is seen as an investment decision. Gibbs approach emphasizes holding costs, costs of short and costs of long-term borrowing and the costs of investment in marketable securities, (Erkki, 2004).

In order to do this a variety of activities need to be undertaken, because of the integrative nature of cash to the operation of the SACCO. Since most of the SACCO operations revolve around advancement of cash then it is imperative for a considerable minimum level of cash to be maintained. How a SACCO manages cash will definitely have implications on the

liquidity of the SACCO. The theory therefore is of essence on the bases of the policy the SACCOs may have in place with regard to cash retention so as to avoid illiquidity.

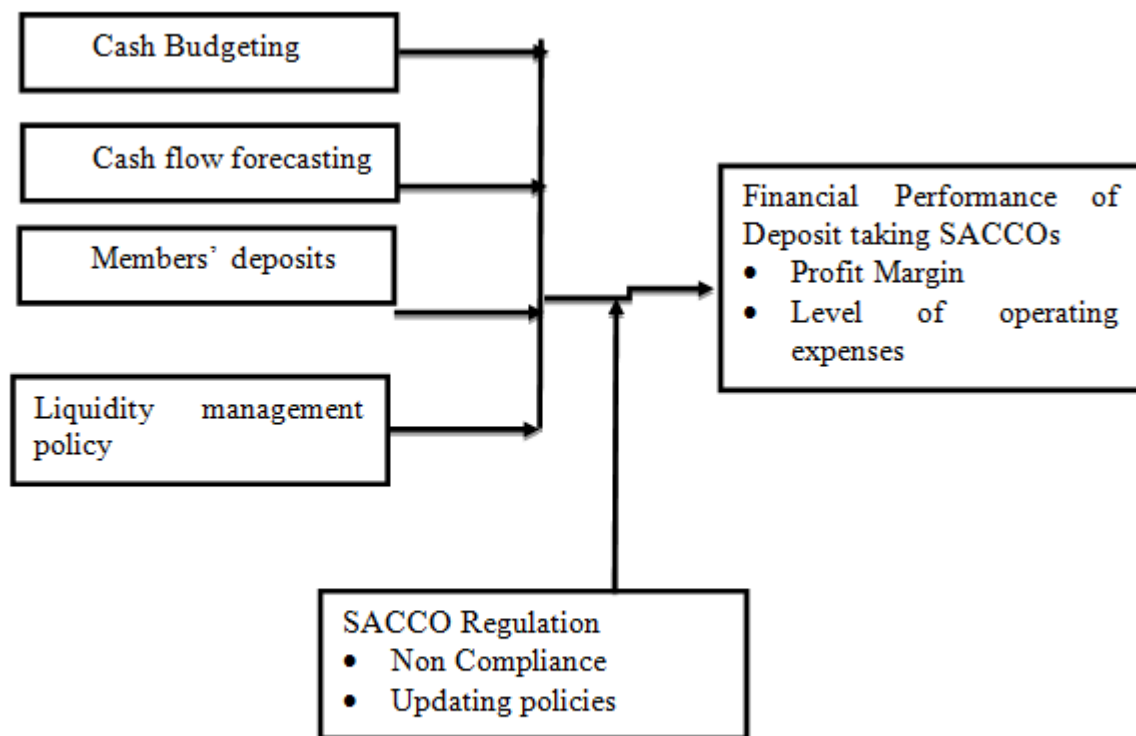
**2.2.2 Free cash flow theory**

As Huseyin (2011) asserts, managers have an incentive to hoard cash to increase the amount of assets under their control and to gain discretionary power over the firm investment decision, (as cited in Jensen, 1986). Having cash available to invest, the manager does not need to raise external funds and to provide capital markets detailed information about the firm’s investment projects (Huseyin, 2011). Hence, managers could undertake investments that have a negative impact on shareholders wealth. Managers of firms with poor investment opportunities are expected to hold more cash to ensure the availability of funds to invest in growth projects, even if the NPV

of these projects is negative(Huseyin,2011). This would lead to destruction of shareholder value and, even if the firm has a large investment programme and a low market-to-book ratio. Thus, using the market-to-book ratio as a proxy, it is likely that the relation between investment opportunity set and cash holdings will be negative. This is critical in management of liquidity in the firm and ensuring there is a balance between meeting the current obligation to mitigate liquidity short fall and investing in the interest of shareholders wealth maximization (Huseyin, 2011).

**2.3 Conceptual framework**

As Sammy (2013) asserts, a conceptual framework refers to a group of concepts that are systematically organized in providing a focus, rationale and a tool for interpretation and integration of information (as cited in Balachander & Soy, 2003). This is usually achieved in pictorial illustrations.



**Independent Variables**

**Moderating Variable**

**Dependent Variable**

**2.4 Empirical Review**

As Nyabwanga (2011) asserts, cash management is the process of planning and controlling cash flows into and out of the business, cash flows within the business, and cash balances held by a business at a point in time (as cited in Pandey, 2004). As Nyabwanga (2011) asserts, efficient cash management involves the determination of the optimal cash to hold by considering the trade-off between the opportunity cost of holding too much cash and the trading cost of holding too little (as cited in Ross et al., 2008) and as stressed by (as cited in Atrill, 2006), there is need for careful planning and

monitoring of cash flows over time so as to determine the optimal cash to hold. A study by (Kwame, 2007) established that the setting up of a cash balance policy ensures prudent cash budgeting and investment of surplus cash. This finding agree with the findings by (Kotut, 2003) who established that cash budgeting is useful in planning for shortage and surplus of cash and has an effect on the financial performance of the firms. The assertion by (Ross et al., 2008) that reducing the time cash is tied up in the operating cycle improves a business’s profitability and market value furthers the

significance of efficient cash management practices in improving business performance.

Erkki (2004) defined cash management as a part of treasury management, which is defined as a part of the main responsibilities of the central finance management team (as cited in Tiegen, 2001). Huseyin (2011) asserts, the specific task of a typical treasury function include cash management, risk management, hedging and insurance management, account receivable management, account payable management, bank relations and investor relations (as cited in Kytönen, 2004). (Huseyin, 2011) thinks that this definition is consistent with the (as cited in Srinivasan & Kim, 1986) classification of cash management areas as cash balance management, cash gathering, cash mobilization and concentration, cash disbursement, and banking system design. Cash balance management includes management of cash position, short-term borrowing, short term investing, cash forecasting. (Huseyin, 2011) opinion is that the classifications of Tiegen's cash management and Srinivasan and Kim's cash balance management are closely related concepts. (Huseyin, 2011) classifies cash management as operating transactions and financial transactions. The operating transactions include accounting ledgers, invoicing, terms of sales - cash collection, cash control and processing, cash forecasting. The financial transactions include optimization of cash, short-term investments, short term borrowing, interest rate risk management, exchange rate risk management, payment systems, information systems and banking investor relations (as cited in Kytönen, 2004).

As Jared (2013) asserts, the cooperative form is therefore regarded as having enormous potential for delivering pro-poor growth that is owned and controlled by poor people themselves. Nevertheless it is recognised that, lacking in capital and business management capacity, cooperatives have had a rather disappointing history in developing countries (as cited in Birchall, 2004). There is an argument then that it is the broader characteristics of cooperative organisation such as social ownership, people-centred objectives and their community base, rather than their precise organisational form should be advocated. According to (Mwaura, 2010) industry statistics in Kenya show that an estimated 60 SACCOs are way below the required minimum capital levels — and are expected to turn to the members for money needed to reach the threshold. Contributing money for the capital build-up will force members to take a portion of their monthly take-home or forego annual dividends in the next four years in support of the initiative. Nation staff SACCO has, for example, asked its members to increase their share capital to Sh 6,000 from the current Sh1, 000 in the next five months beginning August 2010.

As observed by (Steve, 2010) Maisha Bora SACCO had withheld part or whole dividends for the year 2009 and encouraged members to invest in beefing up the core capital in order to meet the SACCO liquidity demands. (Haileselassie, 2003) in his study about cooperatives in Saesi-Tsaeda-Imba, investigated that 78.7 percent of the members became member in cooperatives through mobilization and persuasion by the civil societies such as Farmers, Youth and Women's Associations. As a result, the members' were not aware of the duties and rights they have in the cooperative societies. According to Haileselassie's finding, for example, out of the total respondents

members' participation in the annual meeting was 12.2 per cent and 68.8 per cent of the total respondents had bought only one share. The result of the study revealed that the overall participation of members in co-operatives was weak (Haileselassie, 2003).

As Darek (2012) asserts, the problem of access to capital becomes even more challenging in emerging markets for a variety of reasons (as cited in Benedict and Venter, 2010; Cunningham and Rowley, 2010; Klonowski, 2005; Abor and Biekpe, 2006; Tagoeet al., 2005). First, firms in emerging markets operate in an environment of imperfect legal infrastructure (as cited in Cunningham and Rowley, 2010; Klonowski, 2005). Capital providers must often agree to contractual terms that are suboptimal for them. Second, financial disclosure in emerging markets continues to be relatively poor (as cited in Sami and Zhou, 2008; Zhou, 2007; Klonowski, 2007). As Darek (2012) asserts, many countries report financial results under their own financial standards and regulations, which are different from those seen in international accounting standards; consequently, auditing firms must often recast the financial statements of firms operating in such markets. Third, asymmetry of information and moral hazards are more pronounced in emerging markets (as cited in Klonowski, 2007; Tagoeet al., 2005). Access to information is a greater challenge to obtain, as sources of information on firms, the competitive posture of market players, and market size and growth rates are more difficult to find (as cited in Abor and Biekpe, 2006; Tagoeet al., 2005). Fourth, firms operating within emerging markets have more problems related to corporate governance. The corporate governance concerns are more severe and more difficult to address than those experienced by firms in developed economies (as cited in Black et al., 2010; Klonowski and Golebiowska-Tataj, 2009; Parisiet al., 2009; Klonowski, 2007). Key issues may include the personal use of a firm's assets, unaccounted cash withdrawals, appointment of family members, and so on.

(Ondieki, 2011) in "The effects of external financing on the performance of SACCOs in Kisii District" observed that major challenges inherent in the cooperative movement in Kenya included: poor governance, limited transparency in management of cooperatives, weak capital base and infrastructure weakness including ICT. The same opinion is shared by (Karim, 2012) "African SACCO Regulatory framework" whereby it was observed that leadership or governance of a CFI determines to a large extent how the CFI responds to regulatory issues and how it operates within the regulatory framework. This requires that the BOD members file personal information return with the regulators.

According to (Odhiambo, 2013) in his study on the relationship between working capital management and financial performance of deposit taking savings and credit co-operative societies licensed by SACCO societies regulatory authority in Nairobi county. Interest rate on members' deposits as measure of financial performance was used as the dependent variable. The independent variable (working capital management) was measured by cash conversion cycle, current ratio, debt ratio and turnover growth. The findings indicated that efficient working capital management leads to better financial performance of a



SACCO, hence a positive relationship existed between efficient working capital management and financial performance variable. A study on the role of financial management practices in the performance of public service vehicle savings and credit cooperative societies in Kenya was done by (Kinyua, 2013). The objectives of this study were to, describe the profile of P.S.V SACCOs, investigate the role of financial management practices in the P.S.V SACCOs in Nyeri South district, identify areas of financial management that are influential to performance of P.S.V SACCOs, find out whether public transport SACCOs in Nyeri South District generate cash plans and budgets based on their specific priorities and to ensure that incoming financial resources facilitate the fulfillment of these priorities. The findings show that public service vehicle SACCOs have better financial management practices as showed by the six indicators of better financial management. Members' funds are protected against loan delinquency by setting funds and provision for statutory reserve provided for through cooperative Act. SACCOs have effective financial structure, high rate of return and high Loan Repayment. There are signs of growth indicated by positive change in the levels of profitability, turnover and capital. Better financial management practices have resulted to better performance of the SACCOs. The dividends payout for the members of the SACCOs is fairly high and is expanding, annually. The share capital level of the SACCOs has increased over the years of their existence. With expanding saving members are able to access credit facilities resulting to increased number of vehicles. The public service vehicle SACCOs have therefore continued to exist and grow over the years dominating the public transport sector.

## 2.5 Critique of the existing literature relevant to the study

Research article by (Kifle, 2011) on the management of savings and credit cooperatives from the perspective of outreach & sustainability: evidence from Southern Tigray of Ethiopia, the author did cite literature in relation to the area of study. There is enough buildup of information in relation to the research. The paper lacks theoretical framework on where the author builds up his research on. There is lack of sequential chronological order of literature as per specific objectives. The author describes clearly the area of study, provides the study population of ten SACCOs and states the usage of longitudinal research design with 2007 as the baseline. The researcher stated usage of both primary and secondary data and the way it was presented. The researcher failed to state the sampling technique, computation of the sample size and analysis of primary data. Usage of inferential statistics was not clearly stated and there is lack of econometric model to show the relationship between variables and establish the predictive nature of the information.

## III. FINDINGS

### 4.1 Introduction

This section highlights the analysis of data based on objective, independent variable and Presentation of research findings and discussions of the results.

### 4.2 Response Rate

From the data collected, out of the 92 questionnaires administered, 68 were filled and returned, which represents 74% response rate. This response rate is considered satisfactory to make conclusions for the study.

### 4.3 Cash Management

The research objectives was to find the effect of cash management on financial performance of deposit taking SACCOs in Mount Kenya Region.

From the findings the researcher established that most SACCOs prepare cash budget regularly as indicated by mean of 4.51, this is strong but with level of dispersion of 0.532 shows that less controls are in place to ensure cash budgets are well prepared. Hence the need of the management to ensure stronger controls are in place in preparation of regular cash budget and this will be well represented by a smaller standard deviation.

From the finding the researcher also established that most SACCOs prepare cash flow forecast in order to inform critical decision in relation to financial performance as shown by a mean value of 4.01, this is well represented since the median is 4.00 which shows cash flow forecast is done and taken seriously in the SACCOs. Across the number of SACCOs, the process is not standard since the standard deviation of 0.743 is very high in comparison to preparation of regular cash budget. This reviewed that management is aware of the need of preparation of cash flow forecast and its implication on the financial performance of the SACCOs.

From the findings the researcher also established there was occurrence of both cash surpluses and shortages as indicated by mean of 2.93 and 2.78. The data showed that shortages were greater than surpluses. This raised an alarm in terms of cash management since it greatly affects day to day operation of the institution since cash is the key engine in the operation of the SACCOs. Also the standard deviation is on the higher side namely 0.719 and 0.878 hence the dispersion levels are high. This shows even though SACCOs undertake strict cash flow forecast, there are external variables that can affect cash management which poses a greater risk in the operations of the institutions. Hence the need to critically review in-depth on the factors both in the external environment and internal environment that can affect cash management in the institution and establish mitigating factors.

From the findings the researcher established that the monthly members' contribution was low as indicated by mean of 3.25, and strengthened by median of 3. This raises a great concern in the cash management of the SACCOs since members' contribution provides direct cash in the institution. The management need to find ways to encourage regular contribution of the members since it will affect the financial performance of the institution. Also the researcher established the level of dispersion was very high as reviewed by standard deviation of 1.238 hence it poses a high risk in the management of cash in deposit taking SACCOs. Hence the need of establishing good mechanism to encourage increase in membership contribution to boost financial performance of the SACCOs.

The researcher wished to establish the constraints SACCOs undergo during cash management. The researcher established that the main challenges as per the respondents were: lack of members integrity in relation to liquidity management; lack of

proper channels followed during liquidation process; methods and the techniques of depreciating assets; high level of loan demands and high loan default rate. Hence the advice of the researcher to the SACCO management to address the listed challenges on liquidity management soonest possible since it will result on improved financial performance of the institutions.

#### 4.4 Hypothesis Testing

There is a Strong positive relationship between cash management and Financial Performance of Deposit taking SACCOs in Mount Kenya Region as indicated by correlation of 0.584. The p-Value of 0.000 is less than the acceptable significance level ( $\alpha$ ), hence the null hypothesis that there is no relationship between Cash Management and Financial Performance of Deposit taking SACCOS in Mount Kenya Region is rejected. This shows that the sampled data can be applied to the general population across deposit taking SACCOs at 95% confidence level.

#### 4.5. Summary

Cash management is very critical as a liquidity management tool in deposit taking SACCOs the researcher studies the following parameters namely: preparation of regular cash budget, cash flow forecast, occurrence of cash shortages and surplus and monthly members' contribution. The researcher concluded that deposit taking SACCOs need to address the parameters critically to ensure that there is adequate cash management policy within the institution to ensure optimal financial performance of deposit taking SACCOs since they have a great role on the achievement of vision 2030 and the sector is a great contributor on the financial sector in the Kenyan economy. The management need to ensure there are adequate cash management controls to ensure all the time there is optimal cash where there are strategies to be in place during minimal cash and surplus cash since either of the side will contribute to liquidity risks to the organization.

#### IV. RECOMMENDATION

The following are the recommendation from this research study:

There is need for the regulator to introduce cash management controls that will be applied across all the deposit taking SACCOs. This will go way further towards increased cash management in the sector and contributes towards better financial performance in the sector.

There is need for the regulator to introduce cash ration to be deposited within the SACCO regulator. This will enable control of liquidity in the deposit taking SACCOs and also help on overnight borrowing to assist the SACCOS assess the regulator during cash shortage and release cash surpluses when there is excess funds.

#### REFERENCES

- [1] Clement, O., & Martin, O. (2012) Financial Practice as a Determinant of Growth of Savings and Credit Co-Operative Societies' Wealth. (A Pointer to Overcoming Poverty Challenges in Kenya and the Region). International Journal of Business and Social Science Vol. 3 No. 24 [Special Issue – December 2012].

- [2] Darek, K., (2012) Liquidity gaps in financing the SME sector in an emerging market: evidence from Poland. International Journal of Emerging Markets Vol. 7 No. 3, 2012 pp. 335-355 Emerald Group Publishing Limited 1746-8809 DOI 10.1108/17468801211237072.
- [3] Erkki, K., (2004) Cash Management Behavior of Firms and its Structural Change in an Emerging Money Market. Faculty of Economics and Business Administration, Department of Accounting and Finance, University of Oulu
- [4] Huseyin, Y., (2011) Another Perspective to Corporate Cash Management: A New Model and Definition. International Journal of Humanities and Social Science Vol. 1 No. 11 [Special Issue – August 2011].
- [5] Hannah, K., Gekara, M., & Joseph, M. (2013). Effect of operating costs on the financial performance of SACCOs in the banking sector in Kenya. Prime Journal of Business Administration and Management (BAM) ISSN: 2251-1261. Vol. 4(2), pp. 1359-1363, Retrieved from, www.primejournal.org/BAM
- [6] ICA (International Co-operative Alliance) (2005) Statement on the co-operative Identity. Available from the University of Wisconsin Center for Co-operatives at <http://www.wisc.edu/uwcc/rin-html> viewed may 15th,2012 International co-operative
- [7] Jared, M., Charles, M., & Willy, M. (2013) The Challenges Facing Deposit-Taking Savings and Credit Cooperative Societies' Regulatory Compliance in Kenya. A Case of the Gusii Region. Interdisciplinary Journal of Contemporary Research in Business Institute of Interdisciplinary Business Research 1013 VOL 4, NO 12
- [8] Kifle, T., (2011) Management of Savings and Credit Cooperatives from the Perspective of Outreach and Sustainability: Evidence from Southern Tigray of Ethiopia. Research Journal of Finance and Accounting. ISSN 2222-1697 (Paper) ISSN 2222-2847 (Online) Vol 2, No 7/8, 2011 www.iiste.org.
- [9] Kinyua (2013) Role of financial management practices in the performance of public service vehicle savings and credit co-operative societies in Kenya (Published Masters Thesis) University of Nairobi.
- [10] Nyabwanga, R., Ojera, P., Alphonse, J., & Otieno, S., (2011) Effect of working capital management practices on financial performance: A study of small scale enterprises in Kisii South District, Kenya. African Journal of Business Management Vol. 6(18), pp. 5807-5817, 9 May, 2012 Available online at <http://www.academicjournals.org/AJBM> DOI: 10.5897/AJBM11.1418 ISSN 1993-8233.
- [11] Odhiambo, J., (2013) The relationship between working capital management and financial performance of deposit taking savings and credit co-operative societies licensed by SACCO societies regulatory authority in Nairobi county. (Published Masters Thesis) University of Nairobi. URI: <http://erepository.uonbi.ac.ke:8080/xmlui/handle/123456789/12776>
- [12] Republic of Kenya (2008), The SACCO Societies Act 2008, Nairobi, Government printers.
- [13] Sammy, A., Philemon, B., & Juma., (2013) Analysis of Financial Mismatch in Co-Operative Societies: A Case of Kakamega County, Kenya. International Journal for Management Science and Technology (IJMST). Volume 1; Issue 5 Paper- 4 ISSN: 2321-0362 (Print)
- [14] Sambasivam, Y., & Biruk, A. (2013) Financial Performance analysis of GOHE Co-Operatives Savings and Credit Union in Bure Woreda, Ethiopia. International journal research journal of economics and business studies. Debre Markos University, Debre Markos, Ethiopia. Retrieved from [www.theinternationaljournal.org](http://www.theinternationaljournal.org) > RJEBS: Volume: 02, Number: 06, April-2013

#### AUTHORS

**First Author** – Njeru Mugambi Duncan , PhD Finance Candidate, Jomo Kenyatta University of Agriculture and Technology

**Second Author** – Dr. Agnes Njeru , Lecturer, Jomo Kenyatta University of Agriculture and Technology

**Third Author** – Dr. Florence Member , Lecturer, Jomo Kenyatta University of Agriculture and Technology

**Fourth Author** – Ondabu Ibrahim Tirimba , Research Fellow and Lecturer Mount Kenya University, Hargeisa Campus

# Effects of water stress on yield and some yield components of three selected oil crops; Groundnut (*Arachis hypogea* L.), Sunflower (*Helianthus annus* L.) and Sesame (*Sesamum indicum* L.)

Dahanayake Nilanthi, Alawathugoda CJ and Ranawake AL

Department of Agricultural Biology, Faculty of Agriculture, University of Ruhuna, Mapalana, Kamburupitiya, Sri Lanka.

**Abstract-** Groundnut variety Tissa (*Arachis hypogea* L.), Sunflower variety Terkey (*Helianthus annus* L.) and Sesame variety MI3 (*Sesamum indicum* L.) are sensitive to both excessive and deficit water which leads to decrease yield. We studied the growth and reproduction of above oil crops due to 10 day water stress at different growth stages; vegetative (T2), flowering (T3) and at maturity (T4). The study consisted with a control (T1), with daily water supply throughout all growth stages. Experiments were arranged in Complete Randomized Design (CRD) with five replicates and the experiment was repeated two times.

All measured characters; Plant shoot length, Plant root length, Seed weight, Number of flowers and head diameter of flowers were significantly affected by the water stress. Results showed that water stress was highly significant for seed yield and Biological yield. The highest seed yield was obtained in T1 Groundnut (14.1g/plant), Sunflower (9.79g /plant) and Sesame (9.5g/plant) whereas least seed yield belonged in T3 Groundnut (1.9g/plant), Sunflower 5.75g/plant) and Sesame (3.4g/plant). The mean root length was significantly higher in T2 Groundnut (27.58cm), Sunflower (19 cm) and Sesame (14.5cm) compare to all other treatments. Water stress at vegetative stage induced early flowering than other treatments. The highest shoot length Groundnut (80.15cm), Sunflower (163cm) and Sesame (130cm) was recorded in control whereas least height was recorded in T2 Groundnut (54.1cm), Sunflower (130cm) and Sesame (84cm). Water stress at vegetative stage in Sunflower was significantly increased the number of flowers (8.4 flowers/plant) comparing to the water stress at flowering stage (2.4 flowers/plant) which observed with least number of flowers. Furthermore in Sunflower water stress at flowering stage significantly affected to reduce the head diameter of flowers (11.2cm) and highest head diameter (17.9cm) was recorded in control compared to all other treatments. Finally we confirm that water stress at different growth stages; vegetative, flowering and maturity stage significantly affected to the growth and reproduction of Groundnut, Sunflower and Sesame. Our results indicated that drought at flowering stage should be avoided to increase seed yield of Groundnut, Sunflower and Sesame.

**Index Terms-** Groundnut (*Arachis hypogea* L.), Sunflower (*Helianthus annus* L.), Sesame (*Sesamum indicum* L.), water stress, vegetative stage, flowering stage, maturity stage

## I. INTRODUCTION

Groundnut (*Arachis hypogea* L; Fabaceae), Sunflower (*Helianthus annus* L; Asteraceae) and Sesame (*Sesamum indicum* L. Pedaliaceae) are some major oilseed crop in the world. They are cultivated in highlands under rain fed condition in Maha season and in paddy lands under irrigation during yala season in dry and intermediate zones of Sri Lanka.

The main objective in agriculture production, so far, focused mostly on the increasing of yield and production (Ulusoy, E. 2001). Water stress may be more severe at certain growth stages and if this is known, planting can be timed on the basis of weather forecast. This is important in determining the priority of water supply to the plants during the growing season.

Trung B.C *et al* 1985 found that both mung bean and adzuki bean maintained relatively high yield even under severe water stress whereas for groundnut yield was reduced. The water deficit conditions during the Sunflower growing season, adversely affect its vegetative as well as reproductive growth in addition to deterioration the quality of its oil content (Jones,1984). Drought stress during the yield formation period of sunflower reduced yields when compared to full irrigation but the reduction was much less than when stress occurred during flowering period (Stone *et al*, 1996; Tolga and Lokman, 2003). Sunflower is the most susceptible to soil water deficiency at flowering, fertilization and grain fill, whereas at the start and end of the growing period the sensitivity is not so evident (Jana *et al*, 1982; Unger,1986; Stone *et al*, 1996; Erdem and Delibas, 2002). Hong *et al* (1985) indicated that drought stress during vegetative growth reduced seed yield of sesame from 8.5 to 4.3 t ha<sup>-1</sup>.

Water deficit elicits several morphological responses in crop plants (Jones HG, 2004). Most of these responses are adaptive mechanisms to withstand water deficit or drought and to ensure both survival and reproduction under conditions of water deficit stress. There are three main aspects of plant morphological behaviour in relation to drought: the modulation of root growth (Jackson RB *et al*, 2000), the modulation of leaf size and changes in leaf orientation (Chaves *et al* 2003). A fundamental problem with these adaptive responses is that most are aimed at reducing water use and consequently affect plant function and productivity through reduction in photosynthesis (Ribaut J, 2006).

Little or no literature are available on morphological responses of groundnut variety Tissa, Sunflower variety Terkey and Sesame variety MI3 to short periods of water stress imposed

at different growth and development stages or on the recuperative ability of the species from drought stress. Information on the response pattern of morphological traits to drought imposed at different growth stages might provide a basis for development of strategies to stabilize yields of Groundnut, Sunflower and Sesame in semi- arid environments. Therefore, the objective of this study was to evaluate the effect of water stress imposed at different developmental stages on morphological traits and yield of Groundnut, Sunflower and Sesame.

## II. MATERIALS AND METHODS

Experiment was carried out in a research field of faculty of Agriculture, University of Ruhuna, Mapalana, Kamburupitiya, Sri Lanka in 2012. It belongs to Low country wet zone (WL<sub>2</sub>); the average annual rainfall, temperature and relative humidity (during the growing season) were >1900 mm, 27.5<sup>0</sup>C and 72% respectively. Some selected oil crops; Groundnut variety Tissa, Sunflower variety Terkey and Sesame variety MI3 were used as the test varieties.

Nursery media was sterilized by fungicide (Bathione) to prevent pests and diseases incidence. Seeds were germinated in plastic pots (1.5 ft<sup>3</sup>) containing coir dust/topsoil/cow dung/compost (1:1:1) under greenhouse condition for 3 weeks. Thinning was done to maintain two plants per each pot until harvest. Basal dressing for Groundnut (35 kg/ha Urea, 100 kg/ha TSP and 75 kg/ha MOP and 30 kg/ha of urea at 4 weeks after planting), Sunflower (60 kg/ha Urea, 40 kg/ha TSP, 60 kg/ha MOP) and Sesame ((50 kg/ha Urea, 120 kg/ha TSP, 60 kg/ha MOP and Top dressing Urea 60 kg/ha was applied at 4 weeks after planting) was applied before sowing of seeds on pots/beds according to the recommended by the Department of Agriculture, Sri Lanka.

There were four treatments arranged in Complete Randomized Design (CRD) with five replicates. Experiment was repeated twice. The control (T<sub>1</sub>) was full irrigated daily at all growth stages. The other treatments were; water stress at vegetative growth stage (T<sub>2</sub>), water stress at flowering stage (T<sub>3</sub>), water stress at maturity stage (T<sub>4</sub>). Soil water content was measured before giving the water stress at vegetative stage (80%) and at the end of the vegetative stage (60%). That water percentage difference (20%) maintain in other two stages flowering and maturity. It was observed approximately 10 days and then water cut/stress was done for 10 days period in each stage. After that plants were continuously re-watered until collect the yield. Other all management practices had practiced to the plants according to the recommendations of Department of Agriculture, Sri Lanka. After maturity stage plants from each pot were harvested and measured plant height (shoot length and root length), number of pods/flowers per plant, wet and dry weight of seeds for each treatment at each replicate.

Analysis of variance was carried out with the use of Statistical Analysis Systems (SAS version 9.2) software and Duncan's multiple range tests were applied to compare the treatment means.

## III. RESULTS AND DISCUSSION

In present study water stress at three different growth stages; vegetative, flowering, mature and the control; continuously watered one time in each day during every growth stages, were used to examine the effects of drought stress on Groundnut variety Tissa (*Arachis hypogea* L.), Sunflower variety Terkey (*Helianthus annuus*L.) and Sesame variety MI3 (*Sesamum indicum* L) (Fig. 1). Six different parameters were measured and analysis of variance show traits influenced water stress significantly at different growth stages.

Water stress had a highly significant impact on seed yield and biological yield. The highest seed yield was obtained by T1 Groundnut (14.1g/plant), Sunflower (9.79 g /plant) and Sesame (9.5 g/plant) whereas least seed yield belonged in T3 Groundnut (1.9g/plant), Sunflower 5.75g/plant) and Sesame (3.4g/plant) (Table 1a,b,c) (Fig. 2a,b,c). It seems that Groundnut, Sunflower and Sesame are very sensitive for water stress conditions resulting decreases of yield. Effect of water stress on number of pods per plant was highly significant. The highest number of pods per plant was obtained in T1 Groundnut (12/plant), Sesame (17.9/plant) and the least number of pods per plant was obtained in T3 Groundnut (5.2 /plant) and Sesame (11.2/plant) (Fig. 2a,c). Water stress in Groundnut during flowering period may have resulted in death of pegs before pod initiation. After re-watering, the plants resumed flowering reaching physiological maturity with small pods without mature seeds. Plants stressed during maturity stage had a higher number of seeds per plant compared to other stressed treatments. The plants stressed during the vegetative stage also reduced pod number and seed yield. The reduction in seed yield agrees with previous findings on legumes under water stress such as black beans (Nielson *et al*, 1998); faba beans and bambara groundnuts (Mwale SS *et al*, 2007, European Union FP-5 INCO-DC, 2002) and cereals like oats (Sandha BS *et al*, 1977) and maize (Kamara AY *et al*, 2003).

The mean root length was significantly higher in T2 Groundnut (27.58cm), Sunflower (19cm) and Sesame (14.5cm) compare to all other treatments (Table 1a,b,c). The reason is when water stress at vegetative stage roots may induce and penetrate the deep soil to absorb much water. Water stress at vegetative stage induced flowering little earlier than other treatments.

There was a significant difference between control plants and water stressed plants for average shoot length and plant height (Table 1a,b,c). The highest shoot length Groundnut (80.15cm), Sunflower (163cm) and Sesame (130cm) was recorded in control whereas least height was recorded in T2 Groundnut (54.1cm), Sunflower (130cm) and Sesame (84cm). Same results were observed Riahi (2003) in his experiment on sunflower, Cotton, bean and maize. Higher plant height was obtained from higher irrigation frequency; meaningful irrigation applied at all growth stages (Kaya and Kolsarici, 2011). Water stress reduced plant height in plants stressed during the vegetative and flowering stages. This was attributed to reduction of stem and leaf expansion. Water deficit did not affect plant height during the maturity stage because the plants had ceased growing vegetatively by this time. After re-watering, the plants stressed during the vegetative and flowering stage increased in plant height. This may be attributed to resumption of stem cell division and elongation plus leaf expansion.

In Sunflower plants water stress at vegetative stage was significantly increased the number of flowers (8.4 flowers/plant) comparing to the water stress at flowering stage (2.4 flowers/plant) which observed least number of flowers. Furthermore in Sunflower water stress at flowering stage significantly affected to reduce the head diameter of flowers (11.2cm) and highest head diameter (17.9cm) was recorded in control compared to all other treatments (Fig3).

#### IV. CONCLUSIONS

Water stress at flowering stage was observed as a limiting factor for plant height, number of pods per plant, number of flowers per plant, head diameter of the flower and seed weight per plant which caused to significant reduction of seed yield in Groundnut variety Tissa, Sunflower variety Terkey and Sesame variety MI3.

Plant root length is increased when water stress at early vegetative stage, vegetative stage is comparatively drought tolerant than other growth stages.

Water stress at vegetative stage induces early flowering but not increases the final yield.

#### REFERENCES

- [1] Chaves, M.M., J.P. Maroco and J.S. Pereira, 2003. Understanding plant responses to drought from genes to the whole plant. *Funct. Plant Biol.*, 30: 239-264.
- [2] European Union FP-5 INCO-DC, 2002. Increasing the productivity of bambara groundnut (*Vigna subterranea* (L.) verdc.) for sustainable food production in semi-Arid Africa. Final Report 2, pp: 73.
- [3] Jackson, R.B., J.S. Sperry and T.E. Dawson, 2000. Root water uptake and transport: Using physiological processes in global predictions. *Trends Plant Sci.*, 5: 482-488.
- [4] Jones, H.G., 2004. Irrigation scheduling: Advantages and pitfalls of plant-based methods. *J. Exp. Bot.*, 55: 2427-2436.

- [5] Kamara, A.Y., A. Menkir, B. Badu-Apraku and O. Ibikunle, 2003. The influence of drought stress on growth, yield and yield components of selected maize genotypes. *J. Agric. Sci.*, 141: 43-50.
- [6] Kaya M.D. and Kolsarici O., (2011), Seed yield and oil content of sunflower hybrids irrigated at different growth stages, Faculty of Agriculture, University of Ankara, Turkey.
- [7] Mwale, S.S., S.N. Azam-Ali and F.J. Massawe, 2007. Growth and development of bambara groundnut (*Vigna subterranea*) in response to soil moisture: 2. Resource capture and conversion. *Eur. J. Agron.*, 26: 354-362.
- [8] Nielson, D.W. and N.O. Nelson, 1998. Black bean sensitivity to water stress at various growth stages. *Crop Sci.*, 38: 422-427.
- [9] Ribaut, J., 2006. Drought Adaptation in Cereals. Routledge Taylor and Francis Group, UK., pp: 145.
- [10] Riahi nia, S.H., 2003. Evaluation of water stress in corn, sunflower, cotton and bean. M.Sc. thesis of agronomy, Faculty of Agriculture, Ferdowsi University of Mashhad.
- [11] Sandha, B.S. and M.L. Horton, 1977. Response of oats to water deficit. II. growth and yield characteristics. *Agron. J.*, 69: 361-364. Table heading?????
- [12] Trung, B.C., S. Yohsida and Y. Kobayashi, 1985. Influence of soil moisture stress on the nitrogen and grain productivity of mungbean. *Japan J. Crop Sci.*, 54: 72-8
- [13] Ulusoy, E. (2001). Objectives of agricultural techniques in changing conditions and conceptions in 2000 years. In 20 National Agricultural Mechanization Congress. Sanliurfa, Turkey.

#### AUTHORS

**First Author** – Author name, qualifications, associated institute (if any) and email address.

**Second Author** – Author name, qualifications, associated institute (if any) and email address.

**Third Author** – Author name, qualifications, associated institute (if any) and email address.

**Correspondence Author** – Author name, email address, alternate email address (if any), contact number.

**TABLE 1a: Effect of water stress on different parameters at different growth stages of Ground nut plant.**

	Shoot Length (cm)	Root Length (cm)	Number of pods per plant	Wet weight of pods per plant (g)	Wet weight of seeds per plant (g)	Dry weight of seeds per plant (g)
T1	80.15 a	21.05 b	12.0 a	21.74 a	15.24 a	14.1 a
T2	54.10 b	27.58 a	9.7 b	13.36 b	8.03 b	7.0 b
T3	59.80 b	17.06 b	5.2 c	8.52 c	3.1 0c	1.9 c
T4	75.06 a	20.55 b	7.2 b	15.58 b	9.45 b	8.2 b



**TABLE 1b: Effect of water stress on different parameters at different growth stages of Sunflower.**

	Shoot Length (cm)	Root Length (cm)	Number of flowers per plant	Average head diameter of flower (cm)	Wet weight of seed of per plant (g)	Dry weight of seeds per plant (g)
T1	163 a	13 b	5.4 b	17.9 a	9.79 a	6.8 a
T2	130 b	19 a	8.4 a	17.5 a	7.5 a	4.9 a
T3	129 b	13.5 ab	2.4 c	11.2 b	5.75 b	3.2 b
T4	140 b	12 b	5.0 b	16 a	6.4 ab	4.2 ab

**TABLE 1c: Effect of water stress on different parameters at different growth stages of Sesame plant.**

	Shoot Length (cm)	Root Length (cm)	Number of pods per plant	Wet weight of pods per plant (g)	Dry seed weight per plant (g)
T1	130.5a	11.0 b	48.4 a	9.5 a	8.7 a
T2	113.2 a	14.5 a	28.0 b	7.4 b	6.6 b
T3	84.0 b	9.3 b	14.2 c	3.4 d	2.7 c
T4	110.6 a	11.0 b	33.0 b	6.3 c	5.7 b

*Note: Column values followed by the same letter are not significantly different as determined by Duncan's multiple range test (P=0.05). Values in same column with same letter denoted non- significant difference*



**Fig. 1** Field layout a. Groundnut b. Sunflower c. Sesame



**Fig. 2** (a) Pods of groundnut per plant (b) Seeds per plant in each treatment.



**Fig. 2** (b) Seeds of Sunflower per plant (b) Seed filling of sunflower under water stress condition



**Fig. 2** (c) Number of pods of Sesame per plant (b) Number of seeds per replicate



**Fig. 3** Head diameter of Sunflower flowers

