



MIT Open Access Articles

On optimizing low SNR wireless networks using network coding

The MIT Faculty has made this article openly available. ***Please share*** how this access benefits you. Your story matters.

Citation	Thakur, Mohit and Muriel Medard. "On optimizing low SNR wireless networks using network coding." IEEE Global Communications Conference Exhibition & Industry Forum, 2010, 6-10 December, Miami, Florida, USA.
As Published	http://cms.comsoc.org/eprise/main/SiteGen/Globecom_2010/Content/Home/conf_program.html
Publisher	IEEE-Globecom
Version	Author's final manuscript
Accessed	Mon May 09 21:13:41 EDT 2016
Citable Link	http://hdl.handle.net/1721.1/60544
Terms of Use	Attribution-Noncommercial-Share Alike 3.0 Unported
Detailed Terms	http://creativecommons.org/licenses/by-nc-sa/3.0/

On optimizing low SNR wireless networks using network coding

Mohit Thakur

Institute for communications engineering,
Technische Universität München,
80290, München, Germany.
Email: mohit.thakur@tum.de

Muriel Médard

Research Laboratory for Electronics,
Department of Electrical Engineering
& Computer Science,
MIT, Cambridge, MA, USA.
Email: medard@mit.edu

Abstract—The rate optimization for wireless networks with low SNR is investigated. While the capacity in the limit of disappearing SNR per degree of freedom is known to be linear in SNR for fading and non-fading channels, we study the problem of operating in low SNR wireless network with given node locations that use network coding over flows. The model we develop for low SNR physically degraded broadcast channel and multiple access channel respectively operates in a non-trivial feasible rate region. We show that the problem reduces to the optimization of total network power which can be casted as standard linear multi-commodity min-cost flow program with no inherent combinatorially difficult structure when network coding is used with non integer constraints (which is a reasonable assumption). This is essentially due to the linearity of the capacity with respect to vanishing SNR which helps avoid the effect of interference in a low SNR physically degraded broadcast channel and multiple access environment respectively. We propose a fully decentralized Primal-Dual Subgradient Algorithm for achieving optimal rates on each subgraph (i.e. hyperarcs) of the network to support the set of traffic demands (multicast/unicast connections). *Index Terms* - Low SNR degraded broadcast channel, network coding, rate optimization, Primal-Dual Subgradient Method.

I. INTRODUCTION

Wideband fading channels have been studied since the early 1960's. Kennedy showed that for the Rayleigh fading channel at the infinite bandwidth limit, the capacity is similar to the capacity of the infinite bandwidth AWGN channel with the same average received power [1, 2]. The robustness of this result in the case of with or without channel state information helps us to model generally the low SNR wideband wireless networks. Using it as our underlying information-theoretic model to approximate the capacity over a link, we model the general traffic (network demands) for this network and show that the linearity of vanishing SNR in SNR per degree of freedom makes for the fundamental reason for simplicity in our model. Hence, we claim, it is possible to do networking over such model with simplistic and essentially linear approach.

In the context of wideband multipath relay channel it is shown in [3] that the min-cut could be achieved using a non-coherent peaky frequency binning scheme. In our model the rate tuples belong to a non-trivial feasible region which is made of the convex hull of all tuples, i.e. capacity achieving in the limit of vanishing SNR, for subsequently defined low SNR physically degraded broadcast and multiple access channel.

The traffic model we use is quite general. It is divided into

two classes: unicast and multicast (broadcast is considered as a special case of multicast). Where each pair of source and receiver group in the network form a session for a particular class of traffic. But the problem of successfully establishing multicast connections in wireline or wireless networks has been long thought to be NP-Complete using arbitrary directed and undirected network models. With the advent of network coding (ref., [4], [5], [6]), the breaking of the fluid model for data networks i.e. by performing coding over incoming packets, has been able to intrinsically circumvent the combinatorial hardness of the multicast flow problem. Later, it was shown that minimum cost setting up of multicast connections boils down to optimizing subgraph over coded packet networks [7].

In our problem, since we consider a low SNR wireless network with physically degraded Gaussian broadcast channel (where the number of hyperarcs is equal to n for n receiver nodes, instead of 2^n hyperarcs) to optimize the rates over each hyperarc (subgraph) to meet the network traffic demands (which we later show can be casted as a minimum cost multicommodity flow problem for optimizing power over each hyperarc). Also, we consider intra-session network coding for establishing traffic demand sessions.

This paper is organized as follows. Section II is composed of general problem formulation, where we define and develop our underlying information theoretic set-up. Section III consists of a proposal with decentralized solution. We present our results in section IV that support our theory. Finally, we mention concluding remarks in section IV.

II. SET-UP AND PROBLEM FORMULATION

In this section we introduce a general low SNR channel model (Gaussian) and extend it to physically degraded Gaussian broadcast channel, then addressing the interference issue in multiple access. This approach becomes our underlying model and we further develop it to a simple networking model.

A. Low SNR physically degraded Gaussian broadcast channel.

Consider a general wideband fading channel where the input waveform is \mathbf{x} and the output waveform is \mathbf{y} , the fading coefficient matrix is given by \mathbf{h} and \mathbf{n} is the additive white noise. The channel is given by:

$$\mathbf{y} = \sqrt{SNR} * \mathbf{h}\mathbf{x} + \mathbf{n}. \quad (1)$$

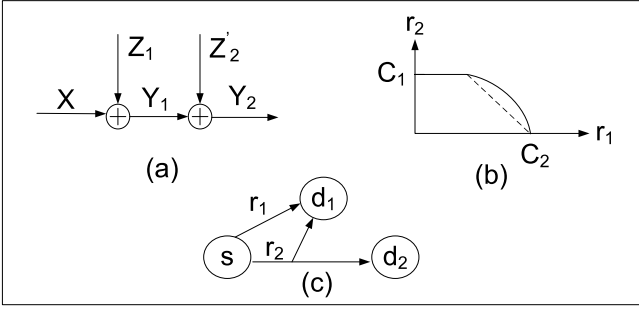

Fig. 1. (a): Two receiver physically degraded Gaussian broadcast channel with $Z_1 \sim \mathcal{N}(0, N_1)$ and $Z_2' \sim \mathcal{N}(0, N_2 - N_1)$. (b): Rate region for the channel in (a), dotted line denotes the flatness of the rate region curve in the limit of vanishing SNR with C_1 and C_2 as max rates for each receiver respectively. (c): Decomposition into hyperarcs $\{(s, (d_1)), (s, (d_1, d_2))\}$ with their common rates for the case in (a) with receivers d_1 and d_2 (corresponding to better and worse respectively).

The capacity of the channel, for both Gaussian channels and fading channels increase sublinearly with the increase in signal to noise ratio (SNR) but in the low SNR regime the capacity in the limit is linear in SNR for fading and non-fading channels:

$$C(\text{SNR}) = \text{SNR} + o(\text{SNR})(\text{nats/s/Hz}). \quad (2)$$

Clearly at low SNR limit, the signal-to-noise ratio per degree of freedom (SNR) approaches unity in the limit [2, 8, 9].

We consider low SNR physically degraded Gaussian broadcast channel, let's look at the standard model of a single sender and 2 receivers with noise variances N_1 and N_2 respectively (ref. Fig 1(a)). The capacity region is given by:

$$r_1 < C\left(\frac{\lambda_1 P}{N_1}\right), r_2 < C\left(\frac{(\lambda_2)P}{\lambda_1 P + N_2}\right). \quad (3)$$

where $C(x) = W(\ln(1+x))$, $\lambda_1 + \lambda_2 = 1$ and P is the total power (ref. Fig. 1(b)). As the channel in consideration is a degraded broadcast channel, the high-resolution receiver (in this case r_1) always get enough information to decode for the second receiver and then cancels it out from the received signal to decode information for itself.

The rate region defined in (3), when looked under the low SNR lens comes across as a rather simpler picture. For the power limited low SNR regime, the effect of the power allocated for the better receiver, as the contribution to the total noise experienced by the worse receiver is negligible (ref. Fig. 1(b), for the rate region for low SNR in the limit). So, for the low SNR physically degraded Gaussian broadcast channel, the rate for the worst receiver can be approximated as

$$r_2 \lesssim C\left(\frac{\lambda_2 P}{N_2}\right). \quad (4)$$

Generalizing the same idea for the case of a given source i with power P_i and n receiver nodes, where the receiver set $J = (1, \dots, n)$ can be broken into n subsets as $J^k = (1, 2, \dots, k)$ for $k \in [1, n]$. The rate region defined for each hyperarc (i, J^k) in the low SNR limit is given as

$$r_{i, J^k} \lesssim C\left(\frac{(\lambda_k)P_i}{N_2}\right), \forall k \in [1, n] \quad (5)$$

$$\approx \frac{(\lambda_k)P_i}{\|L_i - L_k\|_2^{\alpha/2} N_2}, \forall k \in [1, n]. \quad (6)$$

where, $\sum_{k=1}^n \lambda_k \leq 1$, which when combined appropriately gives

the rate region of the set J^k . The equation (6) comes from the fact that the SNR is linear in the limit of disappearing SNR per degree of freedom, where L_i for all $i \in [1, n]$ is the location of the node and α is the path loss exponent. We formalize the above mentioned concepts and motivate our next definition. Let $\lambda_k P_i = P_{i, J^k}, \forall k$.

Definition. 1: For a given sender i with total power P_i and a receiver set $J = [1, K]$ in low SNR physically degraded Gaussian broadcast channel, the set J can be decomposed into K hyperarcs where each hyperarc is defined as the connection from the sender i to the receiver set $J^k = [1, k]$, where $k \subseteq [1, K]$, with individual receiver rates $(r_{i, J^k}, \forall l \in J^k)$ equal to an associated common rate (r_{i, J^k}) of this hyperarc. The rate for each receiver $l \in k$ in the hyperarc is defined as $r_{i, J^k} = r_{i, J^k} = \frac{P_{i, J^k}}{\|L_i - L_l\|_2^{\alpha/2} N_2}$, where, $\sum_k P_{i, J^k} \leq P_i, \forall k \in J$ and the set J^k ranges from best to worst receiver (ref. Fig 1 (c)).

B. Interference issues in multiple access at low SNR.

Now, let's consider the case of multiple access where more than one node tries to access the channel at the given instance. Let there be U nodes in the system at an instance, and $u \subset U$ of them are trying to access the channel at this instance, if node $i \in u$ intends to communicate with node $j \in U$ among others in u , the signal to interference and noise ratio (SINR), denoted as μ_{ij} experienced at node j is given by:

$$\mu_{ij} = \frac{\frac{P_i}{\|L_i - L_j\|^{\alpha/2}}}{2N_0 + \sum_{v \in u, v \neq i} \frac{P_v}{\|L_v - L_j\|^{\alpha/2} 2N_0}}. \quad (7)$$

Note that, since every node in u is interested only in a common receiver, we allocate the whole power of the node over this single hyperarc, so $k = 1$ and $P_{i, J^1} = P_i$ for every transmitter. But as we are operating in the low SNR regime, the intuition suggests that the effect of the interference should be negligible. We straightforwardly include it in our assumption, thus we define the rate (denoted with R) experienced at the receiver j as:

$$R_{ij} = W \ln \left(1 + \frac{\frac{P_i}{\|L_i - L_j\|^{\alpha/2}}}{2N_0 + \sum_{v \in u, v \neq i} \frac{P_v}{\|L_v - L_j\|^{\alpha/2} 2N_0}} \right) \quad (8)$$

$$\approx W \ln \left(1 + \frac{P_i}{\|L_i - L_j\|^{\alpha/2} 2N_0} \right) \quad (9)$$

$$\approx W \left(\frac{P_i}{\|L_i - L_j\|^{\alpha/2} 2N_0} \right). \quad (10)$$

The approximation (9) comes from the fact that the contribution of other signals being transmitted from other sources in the system with low SNR channel to the interference is negligible and the approximation (10) comes from the linearity of SNR in the limit of disappearing SNR per degree of freedom (ref. Fig 2(a) and 2(c)). In Fig. 2(b), we can see that the SNR curve approaches the capacity curve in the limit, corroborating

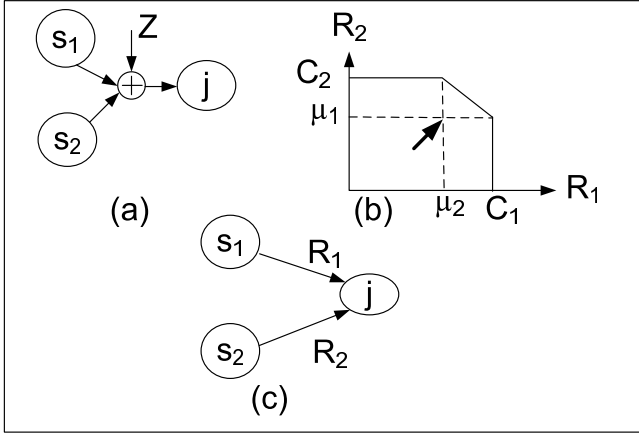

Fig. 2. (a): Two sender case for the low SNR multiple access channel, where $Z \sim \mathcal{N}(0, N)$. (b): Rate region for case in (a), the dotted line denotes the respective SNR's μ_1 and μ_2 for two senders and the arrow shows that in limit of disappearing SNR, the SNR curve touches the capacity curve. (c): As the effect of interference is negligible, the case is (a) can be approximated as individual hyperarcs.

our assumption that the SNR equals capacity in the limit of disappearing SNR per degree of freedom.

We would like to point out here that in [3], it was shown by the authors that with the hyperarc model the non-coherent peaky frequency binning scheme is capacity achieving for the multipath fading relay channel in the limit of large bandwidth for low SNR regime, hence achieving the min-cut.

C. Low SNR network rate optimization.

Let us represent the wireless network as a directed hypergraph $\mathcal{G} = (\mathcal{N}, \mathcal{A})$, where \mathcal{N} is the set of nodes and \mathcal{A} is the set of hyperarcs, where each hyperarc emanates from a node and a terminates at a group of nodes, which we also refer to as the broadcast group of the hyperarc. A hyperarc represents a subgraph which when combined in the appropriate way results in the original hypergraph of the problem. Note that we consider multicast in our multicommodity flow optimization model (as opposed to only unicast), thanks to network coding.

It's important to note that the common rate associated with each hyperarc r_{i,J^k} , is the capacity of the hyperarc, because this is the rate that can be guaranteed to all the receivers for a given transmit power. Also (as defined in the previous subsection), r_{i,J^k} , is a nonnegative function of the transmit power P_{i,J^k} of the hyperarc (i, J^k) . Now that we consider a network with more than one sender, update of notations is required. For a sender $i \in \mathcal{N}$, that is capable of reaching $k_i \in (1, \dots, K_i)$ nodes, where each $k_i \in \mathcal{N} \setminus i$, the K hyperarcs are denoted by $(i, J^{k_i}), \forall k_i \in (1, \dots, K_i)$.

Imagine a set of traffic demands where $m = 1, \dots, M$ sessions need to be established, each with $t_m = 1, \dots, T_m$ set of receivers, in a given wireless network that experiences low SNR channel physically degraded Gaussian broadcast channel and that is represented by the hypergraph $\mathcal{G} = (\mathcal{N}, \mathcal{A})$. We know from the definition of hyperarc that a single node can lie on multiple hyperarcs, therefore, we need a way to carefully count the incoming information and outgoing information to apply the law of flow conservation to the hypergraph and finally be able to cast the problem as a flow optimization

problem. For that, we define another graph $\mathcal{G}' = (\mathcal{N}', \mathcal{A}')$, which is simply the equivalent directed graph of $\mathcal{G} = (\mathcal{N}, \mathcal{A})$ with arcs instead of hyperarcs. This graph can be easily obtained by decomposing the hypergraph appropriately. Let's define the term (ref. [7] for detailed notation explanation):

$$x_{i,J_l^{k_i}} = \sum_{((i, J^{k_i}) \in \mathcal{A} | J^{k_i} \ni l)} x_{i,J^{k_i}}. \quad (11)$$

which simply describes the way to add all the flow entering a node on all incoming hyperarcs, corresponding to the graph $\mathcal{G}' = (\mathcal{N}', \mathcal{A}')$. Notice that $x_{i,J_l^{k_i}}$ is not the same as $r_{i,J_l^{k_i}}$ defined in the previous section, $x_{i,J_l^{k_i}}$ can be interpreted as the flow between i and receiver l of the hyperarc J^{k_i} , and it cannot exceed the common rate ($r_{i,J^{k_i}}$) associated to the hyperarc which is also the hyperarc capacity, for each $l \in k_i$.

Let, $r_{i,J^{k_i}} = \frac{P_{i,J^{k_i}}}{\|L_i - L_{k_i}\|^{\alpha/22N_0}} = \gamma_{i,J^{k_i}} P_{i,J^{k_i}}$. Then, the minimum cost optimization problem for the low SNR network can be formulated as:

$$\text{minimize} \sum_{(i, J^{k_i}) \in \mathcal{A}} P_{i,J^{k_i}} \quad (A)$$

subject to:

$$y_{i,J^{k_i}}(m) \geq \max_{t_m} (x_{i,J^{k_i}}^{t_m}(m)), \forall (i, J^{k_i}) \in \mathcal{A}, \forall m \quad (12)$$

$$z_{i,J^{k_i}} = \sum_{m=1}^M y_{i,J^{k_i}}(m), \forall (i, J^{k_i}) \in \mathcal{A} \quad (13)$$

$$z_{i,J^{k_i}} \leq \gamma_{i,J^{k_i}} P_{i,J^{k_i}}, \forall (i, J^{k_i}) \in \mathcal{A} \quad (14)$$

$$\sum_{k_i=1}^{K_i} P_{i,J^{k_i}} \leq P_i, \forall i \in \mathcal{N}. \quad (15)$$

where P_i is given $\forall i, x_{i,J^k}^{t_m}(m) \in F_{i,J^k}^{t_m}(m)$, and $F_{i,J^k}^{t_m}(m)$ a bounded polyhedron made of flow conservation constraints:

$$\sum_{(J_l^{k_i} | (i, J_l^{k_i}) \in \mathcal{A}')} x_{i,J_l^{k_i}}^{t_m}(m) - \sum_{(J_l^{k_i} | (J_l^{k_i}, i) \in \mathcal{A}')} x_{J_l^{k_i}, i}^{t_m}(m) = s_i(m), \quad (16)$$

$$\forall i \in \mathcal{N}, \forall t_m, \forall m$$

$$x_{i,J_l^{k_i}}^{t_m}(m) = \sum_{(J_l^{k_i} \in J^{k_i} | (i, J_l^{k_i}) \in \mathcal{A})} x_{i,J^{k_i}}^{t_m}(m), \quad (17)$$

$$\forall (i, J_l^{k_i}) \in \mathcal{A}', \forall t_m, \forall m$$

$$x_{i,J_l^{k_i}}^{t_m}(m) \geq 0, \forall (i, J_l^{k_i}) \in \mathcal{A}', \forall m, \forall t_m \in [1, T_m]. \quad (18)$$

As opposed to standard multicommodity flow problem in which flows are simply added over a link, the constraint (12) in fact catches the essence of network coding by taking only the maximum among all the flows of a session (note that we only consider intra-session network coding). Since $F_{i,J^k}^{t_m}(m)$ is the polyhedron formed by the law of flow conservation, constraint (17) translates the flow conservation laws from the underlying directed graph \mathcal{A}' to the hypergraph \mathcal{A} (the wireless network) by adding the flows on all hyperarcs between node i and $J_j^{k_i}$ i.e. flow in $(i, J_j^{k_i}) \in \mathcal{A}'$ is the sum of all the flows on the hyperarcs $(i, J^{k_i}), \forall J^{k_i} \ni J_j^{k_i}$.

As we can see, the above mentioned problem is a convex optimization problem. The only nonlinear constraint is (12), and could be readily replaced by the set of linear inequality constraints $y_{i,J^{k_i}}(m) \geq (x_{i,J^{k_i}}^{t_m}(m)), \forall t_m \in [1, T_m]$. The modified problem results in a standard linear multicommodity flow problem with linear objective and linear constraint set.

$$\text{minimize } \sum_{(i, J^{k_i}) \in \mathcal{A}} P_{i, J^{k_i}}^{k_i} \quad (\text{B})$$

subject to:

$$y_{i, J^{k_i}}(m) \geq (x_{i, J^{k_i}}^{t_m}(m)), \forall t_m, \forall m, \forall (i, J^{k_i}) \in \mathcal{A} \quad (19)$$

$$z_{i, J^{k_i}} = \sum_{m=1}^M y_{i, J^{k_i}}(m), \forall (i, J^{k_i}) \in \mathcal{A} \quad (20)$$

$$z_{i, J^{k_i}} \leq \gamma_{i, J^{k_i}} P_{i, J^{k_i}}^{k_i}, \forall (i, J^{k_i}) \in \mathcal{A} \quad (21)$$

$$\sum_{k_i=1_i}^{K_i} P_{i, J^{k_i}}^{k_i} \leq P_i, \forall i \in \mathcal{N}. \quad (22)$$

where $x_{i, J^{k_i}}^{t_m}(m) \in F_{i, J^{k_i}}^{t_m}(m)$, and $F_{i, J^{k_i}}^{t_m}(m)$ is a bounded polyhedron made of flow conservation constraints. Note that we optimize the power over each hyperarc, to determine the optimal rates for each hyperarc that satisfies the network demands, we simply need to multiply the optimal power with $\gamma_{i, J^{k_i}}$. We will prefer to solve the problem by proposing a decentralized algorithm for generally understood and appreciated reasons.

III. DECENTRALIZED ALGORITHM

For developing a decentralized solution for problem (B) we need to understand the structure of the primal problem first and transform it into a separable form. We know that the objective function is a linear and increasing in its domain and so are the constraints.

Taking the Lagrangian dual of the problem (B) we get the dual optimization problem as:

$$\text{maximize } \left(\sum_{(i, J^{k_i}) \in \mathcal{A}} q_{i, J^{k_i}} + \sum_{i \in \mathcal{N}} \zeta_i P_i \right) \quad (\text{C})$$

$$\text{subject to: } (\lambda, \mu) \geq \mathbf{0} \quad (23)$$

where,

$$\begin{aligned} q_{i, J^{k_i}} &= q_{i, J^{k_i}}(\lambda, \nu, \mu, \zeta, \mathbf{x}, \mathbf{y}, \mathbf{z}, \mathbf{P}) \\ &= \min_{x_{i, J^{k_i}}^{t_m}(m) \in F_{i, J^{k_i}}^{t_m}(m)} \left(P_{i, J^{k_i}}^{k_i} + \right. \\ &\quad \sum_{m=1}^M \sum_{t_m=1}^{T_m} (\lambda_{i, J^{k_i}}^{t_m}(m))(x_{i, J^{k_i}}^{t_m}(m) - y_{i, J^{k_i}}(m)) + \\ &\quad \nu_{i, J^{k_i}} \left(\sum_{m=1}^M y_{i, J^{k_i}}(m) - z_{i, J^{k_i}} \right) + \\ &\quad \left. \mu_{i, J^{k_i}} (z_{i, J^{k_i}} - \gamma_{i, J^{k_i}} P_{i, J^{k_i}}^{k_i}) + \zeta_i P_{i, J^{k_i}}^{k_i} \right). \end{aligned} \quad (24)$$

The dual problem is clearly hyperarc separable and could be solved in a decentralized manner. But the dual problem is not differentiable at all the points in the dual domain, this is due to the fact that there might not be a unique minimizer of $q_{i, J^{k_i}}$ for

every dual point as the objective function is a minimum over sum of linear functions for fixed dual variables. To solve the dual problem (C), we need to solve its subproblem (24). The subproblem (24) (and the dual problem (C)) could be solved with a lot of techniques, [10, Chapters 8-10], [11-Chapters 5-6, 12-Chapters 6] using some subgradient based technique but they do not necessarily yield the primal solution (which is of our interest here). There are however, methods for recovering primal solutions from the dual optimizers.

We will take a different technique than the above mentioned approaches but before lets look into some inter-dependence characteristics of the dual and primal problem structures. Simply having convex primal problem in hand does not guarantee strong duality, but with some constraint qualifications we can assert that strong duality holds or not. One such simple constraint qualification technique is called *Slater's condition*.

In our case it can be easily seen for constraint (12) (or 19) of problem (A) (or (B)), there exist a vector $\{x_{i, J^{k_i}}^{t_m}(m)\}$ for which the inequality can be strict.

Let us represent the set of primal vectors as $\mathbf{p} = \{\mathbf{x}, \mathbf{y}, \mathbf{z}, \mathbf{P}\} \in S_1$ where S_1 is the feasible set for the primal problem, and similarly we can do it for the dual problem, $\mathbf{d} = \{\lambda, \nu, \mu, \zeta\} \in S_2$. As we can see that the primal and dual optimal are equal (thanks to strong duality), we can express our problem in the standard saddle point form $\max_{\mathbf{p} \in S_1} \min_{\mathbf{d} \in S_2} \phi(\mathbf{p}, \mathbf{d}) = \min_{\mathbf{p} \in S_1} \max_{\mathbf{d} \in S_2} \phi(\mathbf{p}, \mathbf{d})$, where function ϕ is the Lagrangian dual of the problem (B). This implies that for (C), we get the hyperarc separable saddle-point form

$$\max_{\mathbf{d} \in S_2} q_{i, J^{k_i}} = \min_{\mathbf{p} \in S_1} \max_{\mathbf{d} \in S_2} \phi(\mathbf{p}, \mathbf{d}). \quad (25)$$

Now we are in the position where we can solve the problem, separable in hyperarcs using any saddle-point optimization method for non-smooth functions. For our problem set up, we propose a Primal-Dual Subgradient Algorithm by Nesterov for nonsmooth optimization [ref. 13]. Nesterov's method generates a subgradient scheme intelligently based on Dual-Averaging method which beats the lower case complexity bound for any black-box subgradient scheme. The algorithm works in both primal and dual spaces, generating a sequence of feasible points, and ultimately squeezing the duality gap to zero by finally approaching the optimal solution. A positive consequence of the Primal-Dual approach is that at each iteration we get a pair of points (\mathbf{p}, \mathbf{d}) which are primal and dual feasible, hence, we get the primal feasible solution with essentially no extra effort. As opposed to many subgradient type methods where there needs to be a method for primal recovery, specially for large and ill-posed problems.

A. Primal-Dual Subgradient Algorithm.

Since the dual function is hyperarc separable, we can optimize the power over each hyperarc separately and add each of the optimal solutions to construct the optimal solution of the dual problem (C), ultimately achieving the primal optimal solution for problem (B). The algorithm is as follows:

- 1) Initialization: Set $s_0 = 0 \in Q$. Choose $\theta > 0$.
- 2) Iteration ($k \geq 0$):

- Compute $g_k = \partial\phi(p_k, d_k)$.
- Choose $\sigma_k > 0$ and set $s_{k+1} = s_k + g_k$.
- Choose $\theta_{k+1} \geq \theta_k$

$$\text{Set } y_{k+1} = \frac{\theta_k}{S_k} \arg \max_{x \in Q} \left(\sum_{i=0}^k \sigma_i \langle g(y_i), y_i - y \rangle \right)$$

where (g_p, g_d) is the set of primal and dual subgradients and σ_k, s_k and S_k are aggregated sequence of points.

IV. SIMULATIONS

We now show the results of our simulations that support the claims of the algorithm presented. We solved the dual problem in a decentralized way by solving it for every hyperarc separately and then adding up the respective solutions to construct the dual optimal solution of the problem (C), which when optimal is the primal optimal solution for problem (A) in our case.

The setup consists of uniformly placed nodes on a chosen area of $a \times a \text{ m}^2$, with given node locations. We start our simulations with smaller networks of only 4 nodes on a $10 \times 10 \text{ m}^2$ area with the area size increasing as the number of nodes in the network increase to keep the node density/area in a controlled range. Each node has a single hyperarc and it can communicate with all the nodes in the network, this is just a simple generalization of our case where a node can communicate with only a subset of total nodes in the network. For each network we randomly choose a set of m multicast sessions and T_m set of receivers for each session respectively with the required rate demand associated with each session that need to be established, but making sure the the traffic demands are \leq the respective min-cut for each session to make the problem feasible.

In Figure 3, we compare the optimal solution approximations of the Primal-Dual Subgradient Method for problem (C) with the standard infeasible path following method for problem (B). It can be seen that the our proposed algorithm gives close approximations of the primal solution of the problem (B). Note that the path following method is directly applied to the primal problem and the Primal-Dual subgradient method is applied to the dual problem, to compute the dual solution of the problem (C), which will be give us the close approximation to the primal solution of problem (A).

V. CONCLUSION

We develop an efficient optimization model that provides an achievable rate region. And we do this by showing that rate optimization for the Low SNR physically degraded broadcast wireless network can be formulated as a standard linear multicommodity flow problem for optimizing power over each hyperarc using network coding. Our model is relieved from interference related issues, this is due to the fact that the capacity of the low SNR wideband channel is essentially linear in SNR per degree of freedom for vanishing SNR in the limit, which relieves the system from interference and related issues. Our model operates in the non-trivial feasible rate region that achieves capacity in the limit of disappearing SNR with appropriate encoding scheme.

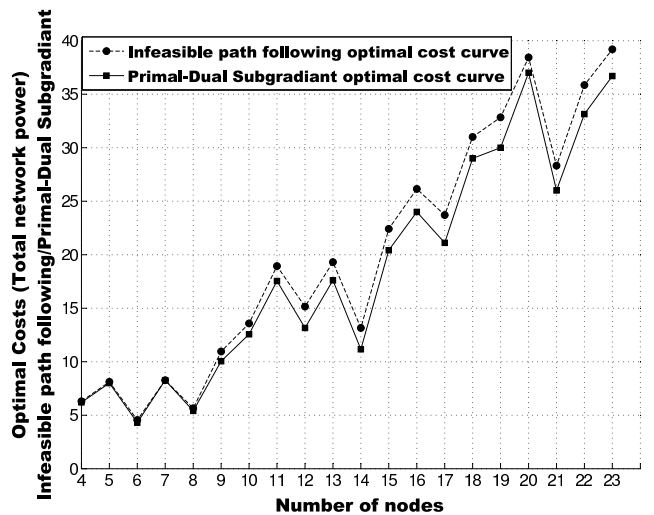

Fig. 3. Y-axis denotes 2 items, optimal primal costs computed using the infeasible path following method when applied directly to primal problem (B) and the optimal cost for the dual (primal optimal solution to (B)) when Primal-Dual Subgradient Algorithm is applied to the dual problem (C).

We use a primal-dual algorithm to construct a decentralized solution for solving the problem, which has apparent advantages for recovering the primal solution than standard projected subgradient methods. In the simulation results shown, we don't present the gains of routing using network coding over simple routing. But there is already a vast literature establishing this fact.

Finally, we believe that realizing low SNR networks is a worthwhile attempt as the linearity of SNR in the limit $\rightarrow 0$ provides a fundamental simplicity for networking to be done. Insights reveal interesting and promising work could be build up and blended with our simple model (e.g. mobility, reliability etc), which remains to be explored in this scenario.

REFERENCES

- [1] R. S. Kennedy, "Fading Dispersive Communication Channels", New York: Wiley-Interscience, 1969.
- [2] E. Telatar, D. N. C. Tse, "Capacity and mutual information of wideband multipath fading channels", IEEE transactions on information theory, vol.46, pp. 1384-1400, July 2000.
- [3] Submitted to ISIT 2010, Nadia Fawaz, Muriel Médard, "On the Non-Coherent Wideband Multipath Fading Relay Channel".
- [4] R. Ahlswede, N. Cai, S.-Y. R. Li, and R. W. Yeung, "Network information flow", IEEE Trans. Inform. Theory, vol. 46, no. 4, pp. 1204-1216, July 2000.
- [5] S.-Y. R. Li, R. W. Yeung, and N. Cai, "Linear network coding", IEEE Trans. Inform. Theory, vol. 49, no. 2, pp. 371-381, Feb. 2003.
- [6] R. Koetter and M. Médard, "An algebraic approach to network coding", IEEE/ACM Trans. Networking, vol. 11, no. 5, pp. 782-795, Oct. 2003.
- [7] D. S. Lun, N. Ratnakar, M. Médard, R. Koetter, D. R. Karger, T. Ho, E. Ahmed, and F. Zhao, "Minimum-cost multicast over coded packet networks", IEEE Trans. Inform. Theory, 52(6):2608-2623, June 2006.
- [8] L. Zheng, D.N.C. Tse, M. Médard, "Channel Coherence in the Low SNR Regime", IEEE International Symposium on Information Theory, June 2004. pg. 416.
- [9] S. Verdú, "Spectral efficiency in the wideband regime", IEEE Trans. Info. Theory, 48(6):1319-1343, June 2002.
- [10] D. P. Bertsekas, *Network Optimization: Continuous and Discrete Models*, Belmont, MA: Athena Scientific, 1998.
- [11] D. P. Bertsekas and R. Gallager, *Data Networks*, 2nd ed. Upper Saddle River, NJ: Prentice Hall, 1992.
- [12] D. P. Bertsekas, *Nonlinear Programming*, Belmont, MA: Athena Scientific, 1995.
- [13] Yu Nesterov, "Primal Dual Subgradient Methods for convex problems", Mathematical Programming, Volume 120, Issue 1 (April 2009).