

\mathcal{W} -CONSTRAINTS FOR THE TOTAL DESCENDANT POTENTIAL OF A SIMPLE SINGULARITY

BOJKO BAKALOV AND TODOR MILANOV

ABSTRACT. Simple, or Kleinian, singularities are classified by Dynkin diagrams of type ADE . Let \mathfrak{g} be the corresponding finite-dimensional Lie algebra, and W its Weyl group. The set of \mathfrak{g} -invariants in the basic representation of the affine Kac–Moody algebra $\hat{\mathfrak{g}}$ is known as a \mathcal{W} -algebra and is a subalgebra of the Heisenberg vertex algebra \mathcal{F} . Using period integrals, we construct an analytic continuation of the twisted representation of \mathcal{F} . Our construction yields a global object, which may be called a W -twisted representation of \mathcal{F} . Our main result is that the total descendant potential of the singularity, introduced by Givental, is a highest weight vector for the \mathcal{W} -algebra.

1. INTRODUCTION

1.1. Motivation from Gromov–Witten theory. Recall that the *Gromov–Witten* (GW) *invariants* of a projective manifold X consist of correlators

$$(1.1) \quad \langle \tau_{k_1}(v_1), \dots, \tau_{k_n}(v_n) \rangle_{g,n,d}$$

where $v_1, \dots, v_n \in H^*(X; \mathbb{C})$ are cohomology classes and the enumerative meaning of the correlator is the following. Let C_1, \dots, C_n be n cycles in X in a sufficiently generic position that are Poincaré dual to v_1, \dots, v_n , respectively. Then the GW invariant (1.1) counts the number of genus- g , degree- d holomorphic curves in X that are tangent (in an appropriate sense) to the cycles C_i with multiplicities k_i . For the precise definition we refer to [103, 75, 8, 83]. After A. Givental [57], we organize the GW invariants in a generating series \mathcal{D}_X called the *total descendant potential* of X and defined as follows. Choose a basis $\{v_i\}_{i=1}^N$ of the vector (super)space $H = H^*(X; \mathbb{C})$ and let $t_k = \sum_{i=1}^N t_k^i v_i \in H$.

Date: March 15, 2012.

2010 Mathematics Subject Classification. Primary 17B69; Secondary 32S30, 53D45, 81R10.

Then

$$\mathcal{D}_X(\mathbf{t}) = \exp\left(\sum_{g,n,d} \frac{Q^d}{n!} \hbar^{g-1} \sum_{k_1, \dots, k_n \geq 0} \langle \tau_{k_1}(t_{k_1}), \dots, \tau_{k_n}(t_{k_n}) \rangle_{g,n,d}\right),$$

where $\mathbf{t} = (t_0, t_1, \dots) = (t_k^i)$ and the definition of the correlator is extended multi-linearly in its arguments. The function \mathcal{D}_X is interpreted as a formal power series in the variables t_k^i with coefficients formal Laurent series in \hbar whose coefficients are elements of the Novikov ring $\mathbb{C}[Q]$.

When X is a point and hence $d = 0$, the potential \mathcal{D}_{pt} (also known as the partition function of pure gravity) is a generating function for certain intersection numbers on the Deligne–Mumford moduli space of Riemann surfaces $\overline{\mathcal{M}}_{g,n}$. It was conjectured by Witten [103] and proved by Kontsevich [74] that \mathcal{D}_{pt} is a tau-function for the *KdV hierarchy* of soliton equations. (We refer to [19, 102] for excellent introductions to soliton equations.) In addition, \mathcal{D}_{pt} satisfies one more constraint called the *string equation*, which together with the KdV hierarchy determines uniquely \mathcal{D}_{pt} (see [103]). It was observed in [22, 54, 69] that the tau-function of KdV satisfying the string equation is characterized as the unique solution of $L_n \mathcal{D}_{\text{pt}} = 0$ for $n \geq -1$, where L_n are certain differential operators representing the *Virasoro algebra*. This means that \mathcal{D}_{pt} is a highest-weight vector for the Virasoro algebra and in addition satisfies the string equation $L_{-1} \mathcal{D}_{\text{pt}} = 0$.

One of the fundamental open questions in Gromov–Witten theory is the Virasoro conjecture suggested by S. Katz and the physicists Eguchi, Hori, Xiong, and Jinzenji (see [33, 34, 30]), which says that \mathcal{D}_X satisfies Virasoro constraints similar to the constraints for \mathcal{D}_{pt} for a certain representation of the Virasoro algebra. The equation $L_n \mathcal{D}_X = 0$ has a simple combinatorial meaning: it gives a rule for simplifying the correlators (1.1) when $v_1 = 1$ and $k_1 = n + 1$.

A natural question is whether the results for $X = \text{pt}$ can be generalized for any projective manifold X . In particular, is there an integrable hierarchy that together with the Virasoro constraints will uniquely characterize the GW invariants of X ? Alternatively, are there other combinatorial rules that will allow us to simplify the correlator (1.1) for any cohomology class v_1 , not only for $v_1 = 1$ (cf. [22, 62])? A representation-theoretic interpretation of such rules is that \mathcal{D}_X is a highest-weight vector for an algebra containing the Virasoro algebra. Answering these questions in general is a very difficult problem. However, there is a class of manifolds for which the problem can be

formulated entirely in the language of differential equations and representation theory.

1.2. Semi-simple Frobenius manifolds and Givental's formula.

Let us denote by (\cdot, \cdot) the Poincaré pairing on $H = H^*(X; \mathbb{C})$. For simplicity of the exposition, we will assume that all non-zero cohomology classes are of even degree only; otherwise one has to view H as a vector superspace (see [76]). The genus-0 GW invariants of X allow one to endow H with a commutative associative product \bullet_t parameterized by $t \in H$, known as the *quantum cup product* [76, 93].

Assuming the basis $\{v_i\}_{i=1}^N$ of H is homogeneous, we also introduce the *Euler vector field* on H :

$$E = \sum_{i=1}^N (1 - d_i) t^i \frac{\partial}{\partial t^i} + \sum_{i=1}^N \rho^i \frac{\partial}{\partial t^i},$$

where $d_i = (1/2) \deg v_i$, and ρ^i and t^i are the coordinates respectively of $c_1(TX)$ and t relative to the basis $\{v_i\}_{i=1}^N$. The Poincaré pairing and the quantum multiplication \bullet_t are homogeneous of degrees respectively $2 - D$ and 1 with respect to E , where $D = \dim_{\mathbb{C}} X$.

One of the key facts in GW theory is that the following system of differential equations is compatible:

$$(1.2) \quad z \partial_{t^i} J(t, z) = v_i \bullet_t J(t, z), \quad 1 \leq i \leq N,$$

$$(1.3) \quad (z \partial_z + E) J(t, z) = \theta J(t, z),$$

where θ is the *Hodge grading operator* defined by $\theta(v_i) = (D/2 - d_i)v_i$.

The quantum multiplication is called *semi-simple* if there are local coordinates u^i on H , known as *canonical coordinates*, in which both the Poincaré pairing and the multiplication assume a diagonal form:

$$\partial/\partial u^i \bullet_t \partial/\partial u^j = \delta_{ij} \partial/\partial u^j, \quad (\partial/\partial u^i, \partial/\partial u^j) = \delta_{ij} / \Delta_j$$

for some non-zero functions Δ_j . Examples of manifolds with semi-simple quantum cohomology include Grassmanians and Fano toric manifolds. It was conjectured by Givental [56] and proved by Teleman [100] that if the quantum multiplication is semi-simple, then \mathcal{D}_X is given by a formula of the following type:

$$(1.4) \quad \mathcal{D}_X(\mathbf{t}) = \widehat{G}_t \prod_{i=1}^N \mathcal{D}_{\text{pt}}(\mathbf{t}^i),$$

where the variables \mathbf{t}^i are the coordinates of \mathbf{t} with respect to the basis $\sqrt{\Delta_i} \partial/\partial u^i$ and \widehat{G}_t is a certain differential operator defined only in terms of the canonical coordinates and certain solutions of the differential equations (1.2) and (1.3) (see Sect. 5 below). Givental's formula (1.4)

implies that \mathcal{D}_X can be reconstructed only from genus-0 GW invariants and the higher-genus theory of the point.

Motivated by GW theory, Dubrovin introduced the notion of a *Frobenius manifold* (see [27, 86]). Locally, this is defined as follows. Let H be a vector space whose tangent spaces $T_t H$ are Frobenius algebras with identity 1, i.e., there exist a non-degenerate bilinear pairing $(\cdot, \cdot)_t$ and a commutative associative multiplication \bullet_t such that $(v \bullet_t w_1, w_2)_t = (w_1, v \bullet_t w_2)_t$. Assume also that the pairing is flat and homogeneous (of degree $2 - D$) with respect to an Euler vector field E . We say that the Frobenius algebras form a *Frobenius structure* of conformal dimension D if the system of equations (1.2), (1.3) is compatible. The notion of semi-simplicity still makes sense in such an abstract setting. Therefore, following Givental [56], we use formula (1.4) to define the *total descendant potential* of the semi-simple Frobenius manifold.

By the results of Givental [57], the Virasoro conjecture holds in the semi-simple case. The construction of integrable hierarchies in the setting of semi-simple Frobenius manifolds was investigated in [27, 29, 31, 55] using the bi-Hamiltonian formalism. The methods of Dubrovin and Zhang are quite remarkable. They have recently confirmed that such an integrable hierarchy exists, provided that a certain conjecture about polynomiality of the Poisson brackets holds [31]. This conjecture was partially proved by Buryak–Posthuma–Shadrin [15, 16] (the polynomiality of the second bracket is still an open problem). Another approach is to derive Hirota’s bilinear equations for the tau-function; see [91, 87, 88, 89, 90, 58, 60, 45].

1.3. Spin curves and the generalized Witten conjecture. Recall from [105, 64] that the moduli space of *h-spin curves* consists of Riemann surfaces C equipped with marked points and a line bundle L together with an isomorphism between $L^{\otimes h}$ and the canonical bundle $K_C(D)$, where D is a divisor supported at the marked points. Different choices of D parameterize connected components of the moduli space. Witten conjectured [105] (see also [64]) that the total descendant potential for *h-spin curves* is a τ -function for the *h*-th Gelfand–Dickey hierarchy. This function is uniquely characterized as the solution that also satisfies the string equation.

Witten’s conjecture can be formulated also in the language of vertex algebras. Let \mathcal{W}_h be the Zamolodchikov–Fateev–Lukyanov *W-algebra* (see Sect. 2.4 below). According to Adler and van Moerbeke [1] there is a unique τ -function for the *h*-th Gelfand–Dickey hierarchy solving the string equation. This unique solution is characterized as a highest weight vector for the vertex algebra \mathcal{W}_h (see also [58, 6]).

On the other hand, the space of miniversal deformations of an A_{h-1} -singularity can be equipped with a semi-simple Frobenius structure (see [97] and Sect. 4.3 below). Givental proved that the corresponding total descendant potential (1.4) is a solution of the h -th Gelfand–Dickey hierarchy satisfying the string equation [58]. Therefore, the proof of Witten’s conjecture was reduced to verifying that the total descendant potential of h -spin invariants coincides with Givental’s function. This was done first by Faber–Shadrin–Zvonkine [37] (now there is a more general approach due to Teleman [100]).

Following a suggestion by Witten, Fan–Jarvis–Ruan [38] generalized the notion of h -spin invariants. They introduced the moduli space of Riemann surfaces equipped with orbifold line bundles satisfying certain algebraic relations, corresponding to a certain class of weighted-homogeneous polynomials. In particular, choosing $f(x) = x^h$ reproduces the h -spin invariants. If the polynomial has an isolated critical point of type $X_N = A_N, D_N, E_6, E_7$ or E_8 (these are the so-called *simple singularities*; see Sect. 4.2 below) the total descendant potential of FJRW-invariants coincides with the total descendant potential of the corresponding singularity.

It was proved by Frenkel–Givental–Milanov [60, 45] that the total descendant potential \mathcal{D}_{X_N} of a simple singularity is a τ -function for the *Kac–Wakimoto hierarchy* of type X_N in the principal realization (see [71]). In the present paper, we will show that \mathcal{D}_{X_N} satisfies suitable *W-constraints*.

1.4. Main result. The Virasoro algebra is a Lie algebra, but the \mathcal{W} -algebras are not because they involve nonlinearities. Instead, they are *vertex algebras* (see [11, 52, 66, 44, 80] and Sect. 2 below). Informally, a vertex algebra is a vector space V endowed with products $a_{(n)}b \in V$ for all $a, b \in V$ and $n \in \mathbb{Z}$. An important example is the *Heisenberg vertex algebra* (or Fock space) \mathcal{F} associated to any vector space \mathfrak{h} equipped with a symmetric bilinear form. We let \mathfrak{h} be the Cartan subalgebra of a finite-dimensional simple Lie algebra \mathfrak{g} of type X_N ($X = A, D, E$), and denote by R the root system.

Following [41, 42, 46], we introduce the *W-algebra* \mathcal{W}_{X_N} as the subalgebra of \mathcal{F} given by the intersection of the kernels of the so-called *screening operators* $e^{\alpha}_{(0)}$ ($\alpha \in R$). Equivalently, \mathcal{W}_{X_N} is the space of \mathfrak{g} -invariants in the basic representation of the affine Kac–Moody algebra $\hat{\mathfrak{g}}$, first considered by I. Frenkel [49]. In particular, \mathcal{W}_{X_N} contains certain Casimirs, the first of which corresponds to the Virasoro algebra. It is also important that \mathcal{W}_{X_N} is invariant under the action of the Weyl group W .

Let $\sigma \in W$ be a Coxeter element. Then the principal realization of the basic representation of $\hat{\mathfrak{g}}$ admits the structure of a σ -twisted representation of \mathcal{F} (see [81, 67, 65] and Sect. 3.4 below). We show that the total descendant potential \mathcal{D}_{X_N} of a simple singularity of type X_N lies in a certain completion of this representation. When restricted to \mathcal{W}_{X_N} , this representation becomes untwisted, and it gives rise to products $a_{(n)}\mathcal{D}_{X_N}$ for every $a \in \mathcal{W}_{X_N}$ and $n \in \mathbb{Z}$. Our main result is the following theorem.

Theorem 1.1. *The total descendant potential \mathcal{D}_{X_N} ($X = A, D, E$) of a simple singularity satisfies the \mathcal{W}_{X_N} -constraints $a_{(n)}\mathcal{D}_{X_N} = 0$ for all $a \in \mathcal{W}_{X_N}$, $n \geq 0$.*

Since \mathcal{W}_{A_N} coincides with \mathcal{W}_{N+1} , the above constraints were previously known for type A_N (see [1, 58, 6]). It was shown by Adler and van Moerbeke [1] that the \mathcal{W} -constraints determine the formal power series \mathcal{D}_{A_N} uniquely. We conjecture that this is true for all simple singularities. For type D_N , we have an explicit form of the \mathcal{W} -constraints, so we expect that one can prove the uniqueness directly as in [1]. It is conceivable that the \mathcal{W} -constraints can be derived from the Kac–Wakimoto hierarchy and the string equation, but we only know how to do this for type A_N (cf. [69, 1, 101]). It will also be interesting to find a matrix model for \mathcal{D}_{X_N} generalizing the Kontsevich model from [74, 1] (cf. [77, 73, 20]).

One may try to define the vertex algebra \mathcal{W}_{X_N} for any isolated singularity by taking R to be the set of *vanishing cycles* (see Sect. 4.1 below). It is easy to see that the Virasoro vertex algebra \mathcal{W}_2 is always contained in \mathcal{W}_{X_N} . One of the problems, however, is to determine whether \mathcal{W}_{X_N} is larger than \mathcal{W}_2 , and to suitably modify the definition of \mathcal{W}_{X_N} so that it is. This will be pursued in a future work.

Let M be a twisted module over a vertex algebra V (see [43, 23] and Sect. 3.1 below). Then for every $a \in V$, there is a formal power series $Y(a, \lambda)$ whose coefficients are linear operators on M . The main idea of the present paper is to construct globally defined operator-valued functions $X(a, \lambda)$ whose Laurent series expansions at $\lambda = \infty$ coincide with $Y(a, \lambda)$. They have the form

$$(1.5) \quad X(a, \lambda) = \sum_K I_a^{(K)}(\lambda) e_K, \quad a \in V,$$

where $\{e_K\}$ is some (graded) basis of $\text{End } M$ and the coefficients $I_a^{(K)}(\lambda)$ are multivalued analytic functions in λ on the extended complex plane $\mathbb{CP}^1 = \mathbb{C} \cup \{\infty\}$ having a finite order pole at finitely many points $u_i \in \mathbb{CP}^1$. The composition of such series and the corresponding operator

product expansion (in the form of Proposition 3.2 below) make sense only locally near each singular point u_i , using the formal $(\lambda - u_i)$ -adic topology. In other words, the n -th product of twisted fields a priori is defined only locally near each singular point. In our case, however, these local n -th products turn out to be global objects: there is a series of the type (1.5) such that its Laurent series expansions at each singular point agree with the given ones.

The above idea is realized here for the Heisenberg vertex algebra \mathcal{F} , giving rise to what may be called a W -twisted representation. It has the property that the monodromy operator associated to a big loop around 0 is given by the action of a Coxeter element $\sigma \in W$, while the monodromy around the other singular points $\lambda = u_i$ is given by simple reflections from W . The construction looks very natural, and it would be interesting to find other examples as well. It is also interesting to compare our approach to other geometric approaches such as [9, 48, 85].

1.5. Organization of the paper. The size of the paper has increased substantially as we tried to make the text accessible to a wider audience. We have included several sections with background material, as well as an extensive list of references (complete only to the best of our knowledge).

Section 2 reviews standard material in the theory of vertex algebras. The main goal is to introduce the notion of a \mathcal{W} -algebra and to construct explicit elements in the \mathcal{W} -algebra (see Proposition 2.3, which is probably new).

In Section 3, we give background material on twisted representations of vertex algebras. We prove a formula for the operator product expansion (see Proposition 3.2), which may be used instead of the Borcherds identity in the definition of a twisted representation. This formula is used later in an essential way in order to extend analytically the twisted fields.

In Section 4, we introduce the main object of our study, the Frobenius manifold structure on the space of miniversal deformations of a germ of a holomorphic function with an isolated critical point. We also recall two important operator series: the calibration \mathcal{S}_t and the formal asymptotical operator R_t , which are used to construct Givental's quantization operator (see (1.4)). Finally, we introduce the period integrals, which are an important ingredient in our construction.

In Section 5, we present Givental's quantization formalism and the definitions of the total descendant and the total ancestor potentials. In particular, we recall how the quantized operators $\widehat{\mathcal{S}}_t$ and \widehat{R}_t act on formal power series.

Section 6 contains the construction of the global twisted operators $X(a, \lambda)$ for all a in the Heisenberg vertex algebra \mathcal{F} (see (1.5)). For $a \in \mathfrak{h} \subset \mathcal{F}$, they are defined using period integrals. All other operators $X(a, \lambda)$ are obtained from the generating ones (with $a \in \mathfrak{h}$) in terms of normally ordered products and propagators, analogously to the Wick formula from conformal field theory. The operators $X(a, \lambda)$ possess remarkable properties. Their monodromy is determined by the action of the Weyl group on \mathcal{F} . Their Laurent series expansions at $\lambda = \infty$ give a σ -twisted representation of \mathcal{F} , while their expansions at the other critical points $\lambda = u_i$ give twisted representations of certain subalgebras of \mathcal{F} . The operators $X(a, \lambda)$ also have nice conjugation properties with respect to $\widehat{\mathcal{S}}_t$ and \widehat{R}_t .

We leave the proof of the properties of the propagators for the next Section 7. There we show that the Laurent expansions of the propagators near ∞ and near the critical points $\lambda = u_i$ agree, i.e., they can be obtained from each other by means of analytic continuation. This is precisely the place where we have to use that the singularity is simple. Our argument relies on the fact that the monodromy group is a finite reflection group and is a quotient of the Artin–Brieskorn braid group by the normal subgroup generated by the squares of the generators (see Lemma 7.3).

In Section 8 we prove Theorem 1.1. We first express the \mathcal{W} -constraints as the condition that the Laurent expansions of $X(a, \lambda)\mathcal{D}_{X_N}$ at $\lambda = \infty$ have no negative powers of λ for $a \in \mathcal{W}_{X_N} \subset \mathcal{F}$. We deduce this from the regularity at each of the critical points $\lambda = u_i$, where the statement reduces to the case of an A_1 -singularity, due to the properties of $X(a, \lambda)$. Then the \mathcal{W} -constraints for \mathcal{D}_{X_N} are reduced to a verification of the Virasoro constraints for $\mathcal{D}_{A_1} = \mathcal{D}_{\text{pt}}$, which are known to be true.

2. VERTEX ALGEBRAS AND \mathcal{W} -ALGEBRAS

The notion of a vertex algebra introduced by Borcherds [11] provides a rigorous algebraic description of two-dimensional chiral conformal field theory (see e.g. [10, 61, 18]). In this section, we briefly recall the definition and several important examples; for more details, see [52, 66, 44, 80].

2.1. Affine Lie algebras. Let \mathfrak{g} be a finite-dimensional Lie algebra equipped with a symmetric invariant bilinear form $(\cdot|\cdot)$, normalized so that the square length of a long root is 2 in the case when \mathfrak{g} is simple. For $\mathfrak{g} = \mathfrak{sl}_{N+1}$ this gives $(a|b) = \text{tr}(ab)$. The *affine Lie algebra*

$\hat{\mathfrak{g}} = \mathfrak{g}[t, t^{-1}] \oplus \mathbb{C}K$ has the Lie brackets

$$(2.1) \quad [a_m, b_n] = [a, b]_{m+n} + m\delta_{m,-n}(a|b)K, \quad a_m = at^m,$$

and K is central (see [65]).

Recall that the generalized *Verma module* $M(\Lambda_0) = \text{Ind}_{\mathfrak{g}[t] \oplus \mathbb{C}K}^{\hat{\mathfrak{g}}} \mathbb{C}$ is defined by letting $\mathfrak{g}[t]$ act trivially on \mathbb{C} and K act as 1. Then K acts as the identity on the whole $M(\Lambda_0)$, so the level is 1. The unique irreducible quotient $V(\Lambda_0)$ of $M(\Lambda_0)$ is known as the *basic representation* (see [65]). Both $V(\Lambda_0)$ and $M(\Lambda_0)$ are highest weight representations with highest weight vectors the image of $1 \in \mathbb{C}$, which we will denote by $\mathbf{1}$. Moreover, due to [53], they both have the structure of a vertex algebra.

2.2. Vertex algebras. A *vertex algebra* [11, 52, 66, 44, 80] is a vector space V (space of states) with a distinguished vector $\mathbf{1} \in V$ (vacuum vector), together with a linear map (state-field correspondence)

$$(2.2) \quad Y(\cdot, \zeta) \cdot : V \otimes V \rightarrow V((\zeta)) := V[[\zeta]][\zeta^{-1}].$$

Thus, for every state $a \in V$, we have the field $Y(a, \zeta) : V \rightarrow V((\zeta))$. This field can be viewed as a formal power series from $(\text{End } V)[[\zeta, \zeta^{-1}]]$, which involves only finitely many negative powers of ζ when applied to any vector. The coefficients in front of powers of ζ in this expansion are known as the *modes* of a :

$$(2.3) \quad Y(a, \zeta) = \sum_{n \in \mathbb{Z}} a_{(n)} \zeta^{-n-1}, \quad a_{(n)} \in \text{End } V.$$

As usual, the *formal residue* Res_ζ of a formal power series is defined as the coefficient of ζ^{-1} . Then

$$(2.4) \quad a_{(n)} = \text{Res}_\zeta \zeta^n Y(a, \zeta).$$

The vacuum vector $\mathbf{1}$ plays the role of an identity in the sense that

$$a_{(-1)}\mathbf{1} = \mathbf{1}_{(-1)}a = a, \quad a_{(n)}\mathbf{1} = 0, \quad n \geq 0.$$

In particular, $Y(a, \zeta)\mathbf{1} \in V[[\zeta]]$ is regular at $\zeta = 0$, and its value at $\zeta = 0$ is equal to a . The main axiom for a vertex algebra is the following *Borcherds identity* (also called Jacobi identity [52]) satisfied by the modes:

$$(2.5) \quad \sum_{j=0}^{\infty} (-1)^j \binom{n}{j} \left(a_{(m+n-j)}(b_{(k+j)}c) - (-1)^n b_{(k+n-j)}(a_{(m+j)}c) \right) \\ = \sum_{j=0}^{\infty} \binom{m}{j} (a_{(n+j)}b)_{(k+m-j)}c,$$

where $a, b, c \in V$. Observe that the above sums are finite, because $a_{(n)}b = 0$ for sufficiently large n .

We say that a vertex algebra V is (strongly) *generated* by a subset $S \subset V$ if V is linearly spanned by the vacuum $\mathbf{1}$ and all elements of the form

$$a_{1(n_1)} \cdots a_{r(n_r)} \mathbf{1}, \quad \text{where } r \geq 1, a_i \in S, n_i < 0.$$

2.3. Lattice vertex algebras. Let Q be an (even) integral lattice with a symmetric nondegenerate bilinear form $(\cdot|\cdot)$. We denote by $\mathfrak{h} = \mathbb{C} \otimes_{\mathbb{Z}} Q$ the corresponding complex vector space considered as an abelian Lie algebra. The affine Lie algebra $\hat{\mathfrak{h}} = \mathfrak{h}[t, t^{-1}] \oplus \mathbb{C}K$ is called the *Heisenberg algebra*. Its irreducible highest weight representation

$$\mathcal{F} := M(\Lambda_0) \cong S(\mathfrak{h}[t^{-1}]t^{-1})$$

is known as the (bosonic) *Fock space*.

Following [50, 11], we consider a certain 2-cocycle $\varepsilon: Q \times Q \rightarrow \{\pm 1\}$ such that

$$(2.6) \quad \varepsilon(\alpha, \alpha) = (-1)^{|\alpha|^2(|\alpha|^2+1)/2}, \quad |\alpha|^2 := (\alpha|\alpha), \quad \alpha \in Q,$$

and the algebra $\mathbb{C}_\varepsilon[Q]$ with a basis $\{e^\alpha\}_{\alpha \in Q}$ and multiplication

$$e^\alpha e^\beta = \varepsilon(\alpha, \beta) e^{\alpha+\beta}.$$

Such a 2-cocycle ε is unique up to equivalence, and can be chosen to be bimultiplicative.

The *lattice vertex algebra* [11, 52, 66, 44, 80] is the tensor product $V_Q = \mathcal{F} \otimes \mathbb{C}_\varepsilon[Q]$, where the vacuum vector is $\mathbf{1} \otimes e^0$. We let the Heisenberg algebra act on V_Q so that

$$a_n e^\beta = \delta_{n,0} (a|\beta) e^\beta, \quad n \geq 0, \quad a \in \mathfrak{h}, \quad a_n = at^n.$$

The state-field correspondence on V_Q is uniquely determined by the generating fields:

$$(2.7) \quad Y(a_{-1}\mathbf{1}, \zeta) = \sum_{n \in \mathbb{Z}} a_n \zeta^{-n-1}, \quad a \in \mathfrak{h},$$

$$(2.8) \quad Y(e^\alpha, \zeta) = e^\alpha \zeta^{\alpha_0} \exp\left(\sum_{n < 0} \alpha_n \frac{\zeta^{-n}}{-n}\right) \exp\left(\sum_{n > 0} \alpha_n \frac{\zeta^{-n}}{-n}\right),$$

where $\zeta^{\alpha_0} e^\beta = \zeta^{(\alpha|\beta)} e^\beta$.

Notice that $\mathcal{F} \subset V_Q$ is a vertex subalgebra, which we call the *Heisenberg vertex algebra*. The map $\mathfrak{h} \rightarrow \mathcal{F}$ given by $a \mapsto a_{-1}\mathbf{1}$ is injective. From now on, we will slightly abuse the notation and identify $a \in \mathfrak{h}$ with $a_{-1}\mathbf{1} \in \mathcal{F}$; then $a_{(n)} = a_n$ for all $n \in \mathbb{Z}$.

2.4. The vertex algebra \mathcal{W}_{X_N} . Let \mathfrak{g} be a finite-dimensional simple Lie algebra of type X_N ($X = A, D, E$). We denote by R and Q the set of roots and the root lattice, respectively. Following [42], we define \mathcal{W}_{X_N} as the intersection of the Fock space $\mathcal{F} \subset V_Q$ and the kernels of all *screening operators*

$$e^\alpha_{(0)} = \text{Res}_\zeta Y(e^\alpha, \zeta), \quad \alpha \in R.$$

In a vertex algebra, any zero mode acts as a derivation of the products $a_{(n)}b$ defined by (2.3), and the kernel of a derivation is a vertex subalgebra (see e.g. [66]). Thus, $\mathcal{W}_{X_N} \subset \mathcal{F}$ is a vertex subalgebra. The vertex algebras \mathcal{W}_{X_N} are examples of non-linear extensions of the Virasoro algebra known as *W-algebras* (see [106, 40, 13, 41, 42, 47, 46, 44, 17] and the references therein).

The algebra \mathcal{W}_{X_N} contains the *Virasoro element*

$$\omega = \frac{1}{2} \sum_{i=1}^N v_{(-1)}^i v_i \in \mathcal{W}_{X_N} \subset \mathcal{F},$$

where $\{v_i\}$ and $\{v^i\}$ are bases of \mathfrak{h} dual with respect to $(\cdot|\cdot)$. The modes $L_n = \omega_{(n+1)}$ satisfy the commutation relations of the Virasoro algebra with central charge N (see e.g. [66]). The operator L_0 provides a grading of V_Q such that $\deg a_n = -n$ and $\deg e^\alpha = |\alpha|^2/2$ for $a \in \mathfrak{h}$, $\alpha \in Q$.

It was proved in [42, 46] that the vertex algebra \mathcal{W}_{X_N} is freely generated by N elements of degrees $m_1 + 1, \dots, m_N + 1$, where m_k are the exponents of \mathfrak{g} . This means that \mathcal{W}_{X_N} has a PBW-type basis (see [17] for more on freely generated vertex algebras). For convenience, the exponents of type *ADE* are listed in Table 1 in Sect. 4.2 below.

Remark 2.1. In the case $\mathfrak{g} = \mathfrak{sl}_{N+1}$, the vertex algebra \mathcal{W}_{A_N} coincides with the Zamolodchikov–Fateev–Lukyanov algebra \mathcal{W}_{N+1} introduced in [106, 40], for central charge N . In particular, $\mathcal{W}_{A_1} = \mathcal{W}_2$ is the Virasoro vertex algebra with central charge 1 (cf. [53]).

The Frenkel–Kac construction of the basic representation $V(\Lambda_0)$ can be interpreted as an isomorphism of vertex algebras $V(\Lambda_0) \cong V_Q$ (see [50, 98, 65, 66]). The Lie algebra \mathfrak{g} is realized in V_Q as the zero modes $a_{(0)} = a_0$ for $a \in \mathfrak{h}$ and $e^\alpha_{(0)}$ for $\alpha \in R$. Hence, \mathcal{W}_{X_N} can be identified with the space of \mathfrak{g} -invariants in the basic representation of $\hat{\mathfrak{g}}$, first considered by I. Frenkel [49]. In particular, all elements of \mathcal{W}_{X_N} are fixed by the Weyl group W of \mathfrak{g} .

Example 2.2. For every $d \geq 1$ we have [49]:

$$(2.9) \quad \omega^d := \sum_{i=1}^N v_{(-d)}^i v_i - \sum_{\alpha \in R} e^{\alpha_{(-d)}} e^{-\alpha} \in \mathcal{W}_{X_N}.$$

Note that $\deg \omega^d = d + 1$, and ω^1 is a scalar multiple of ω by the Sugawara construction (see e.g. [66]).

Another way to construct elements of \mathcal{W}_{X_N} is provided by the next result, which seems new.

Proposition 2.3. *Suppose that $\lambda_0 \in \mathfrak{h}$ is such that $(\lambda_0|\alpha) = 0, \pm 1$ for all $\alpha \in R$. Then*

$$(2.10) \quad \nu^d := \sum_{\lambda \in W\lambda_0} e^{\lambda_{(-d)}} e^{-\lambda} \in \mathcal{W}_{X_N}.$$

Proof. It suffices to check that $e^{\alpha_{(0)}} \nu^d = 0$ for all $\alpha \in R$. Since $e^{\alpha_{(0)}}$ is a derivation, we have

$$e^{\alpha_{(0)}} \nu^d = \sum_{\lambda \in W\lambda_0} (e^{\alpha_{(0)}} e^{\lambda})_{(-d)} e^{-\lambda} + \sum_{\lambda \in W\lambda_0} e^{\lambda_{(-d)}} (e^{\alpha_{(0)}} e^{-\lambda}).$$

By (2.8),

$$e^{\alpha_{(0)}} e^{\lambda} = \text{Res}_{\zeta} Y(e^{\alpha}, \zeta) e^{\lambda} = \text{Res}_{\zeta} \varepsilon(\alpha, \lambda) \zeta^{(\alpha|\lambda)} \exp\left(\sum_{n < 0} \alpha_n \frac{\zeta^{-n}}{-n}\right) e^{\lambda + \alpha}$$

is zero for $(\alpha|\lambda) \geq 0$ and is equal to $\varepsilon(\alpha, \lambda) e^{\lambda + \alpha}$ when $(\alpha|\lambda) = -1$. Now if $(\alpha|\lambda) = -1$ for some $\lambda = w\lambda_0$, then $(\alpha| -r_{\alpha}\lambda) = (\alpha| -\lambda - \alpha) = -1$ as well. Due to (2.6) and bimultiplicativity,

$$\varepsilon(\alpha, -r_{\alpha}\lambda) = \varepsilon(\alpha, \lambda + \alpha) = \varepsilon(\alpha, \lambda) \varepsilon(\alpha, \alpha) = -\varepsilon(\alpha, \lambda).$$

Therefore, the terms with $e^{\lambda_{(-d)}} e^{-\lambda}$ and $e^{r_{\alpha}\lambda_{(-d)}} e^{-r_{\alpha}\lambda}$ cancel. \square

Example 2.4. The roots of type A_N can be realized as $v_i - v_j$ where $\{v_i\}$ is an orthonormal basis for \mathbb{R}^{N+1} . The Weyl group $W = S_{N+1}$ acts by permutations on v_1, \dots, v_{N+1} . Then $\lambda_0 = v_1$ satisfies the condition of Proposition 2.3, and

$$\nu^d = \sum_{i=1}^{N+1} e^{v_i_{(-d)}} e^{-v_i} \quad \text{mod } (v_1 + \dots + v_{N+1}) \in \mathcal{W}_{A_N}.$$

Note that the fields $Y(e^{\pm v_i}, \zeta)$ are the so-called charged free fermions (see e.g. [66]). It follows from the results of [49, 46] that the elements ν^d ($1 \leq d \leq N$) generate \mathcal{W}_{A_N} .

Example 2.5. The roots of type D_N can be realized as $\pm v_i \pm v_j$, where $\{v_i\}$ is an orthonormal basis for \mathbb{R}^N . The Weyl group acts on v_1, \dots, v_N by permutations and an even number of sign changes. Then $\lambda_0 = v_1$ works and

$$\nu^d = \sum_{i=1}^N e^{v_i(-d)} e^{-v_i} + \sum_{i=1}^N e^{-v_i(-d)} e^{v_i} \in \mathcal{W}_{D_N}.$$

It is not hard to check that we also have

$$\pi^N := v_{1(-1)} \cdots v_{N-1(-1)} v_N \in \mathcal{W}_{D_N}.$$

Due to Theorem 14.2 in [72], \mathcal{W}_{D_N} is generated by π^N and ν^d ($d \geq 1$).

Example 2.6. The root system of type E_N ($N = 6, 7$) can be realized in terms of an orthonormal basis $\{v_i\}$ for \mathbb{R}^{N+1} (see e.g. [65], Chapter 6). Then $\lambda_0 = v_1 + v_2$ satisfies the condition of Proposition 2.3. In the case of E_8 such an element λ_0 does not exist.

3. TWISTED REPRESENTATIONS OF VERTEX ALGEBRAS

In this section, we review the notion of a twisted representation of a vertex algebra, and we derive several properties of twisted representations. We also discuss twisted representations of the \mathcal{W} -algebras \mathcal{W}_{X_N} .

3.1. Definition of twisted representation. Let V be a vertex algebra, as in Sect. 2.2. A *representation* (or *module*) of V is a vector space M endowed with a linear map $Y(\cdot, \zeta) \cdot : V \otimes M \rightarrow M((\zeta))$ (cf. (2.2), (2.3)) such that the Borcherds identity (2.5) holds for $a, b \in V$, $c \in M$ (see [44, 80]).

Now let σ be an automorphism of V of a finite order h . Then σ is diagonalizable. In the definition of a σ -*twisted representation* M of V [43, 23], the image of the above map Y is allowed to have nonintegral (rational) powers of ζ . More precisely,

$$(3.1) \quad Y(a, \zeta) = \sum_{n \in p + \mathbb{Z}} a_{(n)} \zeta^{-n-1}, \quad \text{if } \sigma a = e^{-2\pi\sqrt{-1}p} a, \quad p \in \frac{1}{h}\mathbb{Z},$$

where $a_{(n)} \in \text{End } M$. Equivalently, the monodromy around $\zeta = 0$ is given by the action of σ :

$$(3.2) \quad Y(\sigma a, \zeta) = Y(a, e^{2\pi\sqrt{-1}} \zeta), \quad a \in V.$$

The Borcherds identity (2.5) satisfied by the modes remains the same in the twisted case.

The above notion of a twisted representation axiomatizes the properties of the so-called “twisted vertex operators” [68, 78, 51, 79], which

were used in the construction of the “moonshine module” vertex algebra in [52]. When restricted to the σ -invariant subalgebra $V^\sigma \subset V$ (known as an *orbifold*; see [21, 70, 26] among many other works), a σ -twisted representation for V becomes untwisted for V^σ .

3.2. Consequences of the Borcherds identity. For a rational function $f(\zeta_1, \zeta_2)$ with poles only at $\zeta_1 = 0$, $\zeta_2 = 0$ or $\zeta_1 = \zeta_2$, we denote by ι_{ζ_1, ζ_2} (respectively, ι_{ζ_2, ζ_1}) its expansion in the domain $|\zeta_1| > |\zeta_2| > 0$ (respectively, $|\zeta_2| > |\zeta_1| > 0$). Explicitly, we have

$$(3.3) \quad \begin{aligned} \iota_{\zeta_1, \zeta_2} \zeta_{12}^n &= \sum_{j=0}^{\infty} \binom{n}{j} \zeta_1^{n-j} (-\zeta_2)^j, \\ \iota_{\zeta_2, \zeta_1} \zeta_{12}^n &= \sum_{j=0}^{\infty} \binom{n}{j} \zeta_1^j (-\zeta_2)^{n-j}, \quad \text{where } \zeta_{12} = \zeta_1 - \zeta_2. \end{aligned}$$

In particular,

$$(3.4) \quad \delta(\zeta_1, \zeta_2) := (\iota_{\zeta_1, \zeta_2} - \iota_{\zeta_2, \zeta_1}) \zeta_{12}^{-1} = \sum_{j \in \mathbb{Z}} \zeta_1^{-j-1} \zeta_2^j$$

is the formal *delta-function* (see e.g. [66, 80]).

The Borcherds identity (2.5) can be stated equivalently as follows (see [43, 23, 25, 4]).

Lemma 3.1. *The Borcherds identity (2.5) for a σ -twisted representation M of a vertex algebra V is equivalent to:*

$$(3.5) \quad \begin{aligned} &\text{Res}_{\zeta_{12}} Y(Y(a, \zeta_{12})b, \zeta_2)c \iota_{\zeta_2, \zeta_{12}} f(\zeta_1, \zeta_2) \zeta_1^p \\ &= \text{Res}_{\zeta_1} Y(a, \zeta_1) Y(b, \zeta_2)c \iota_{\zeta_1, \zeta_2} f(\zeta_1, \zeta_2) \zeta_1^p \\ &\quad - \text{Res}_{\zeta_1} Y(b, \zeta_2) Y(a, \zeta_1)c \iota_{\zeta_2, \zeta_1} f(\zeta_1, \zeta_2) \zeta_1^p \end{aligned}$$

for $a, b \in V$, $c \in M$ such that $\sigma a = e^{-2\pi\sqrt{-1}p}a$, and every rational function $f(\zeta_1, \zeta_2)$ with poles only at $\zeta_1 = 0$, $\zeta_2 = 0$ or $\zeta_1 = \zeta_2$.

Assume that $\sigma a = e^{-2\pi\sqrt{-1}p}a$ and $\sigma b = e^{-2\pi\sqrt{-1}q}b$ with $p, q \in \frac{1}{h}\mathbb{Z}$. Let N_{ab} be a non-negative integer such that $a_{(n)}b = 0$ for all $n \geq N_{ab}$. Then setting $f(\zeta_1, \zeta_2) = \zeta_1^{m'} \zeta_{12}^{N_{ab}}$ in (3.5) for all $m' \in \mathbb{Z}$, we obtain the *locality* property [24, 82]

$$(3.6) \quad \zeta_{12}^{N_{ab}} Y(a, \zeta_1) Y(b, \zeta_2) = \zeta_{12}^{N_{ab}} Y(b, \zeta_2) Y(a, \zeta_1).$$

An important consequence of (3.6) is that for every $c \in M$

$$\zeta_{12}^{N_{ab}} Y(a, \zeta_1) Y(b, \zeta_2)c \in \zeta_1^{-p} \zeta_2^{-q} M((\zeta_1, \zeta_2)).$$

The elements of this space have the powers of both ζ_1 and ζ_2 bounded from below. Therefore, it makes sense to set $\zeta_1 = \zeta_2$ in such a series,

and the result is an element of $\zeta_2^{-p-q}M((\zeta_2))$. The same is true if we first differentiate the series.

Proposition 3.2. *Let V be a vertex algebra, σ an automorphism of V , and M a σ -twisted representation of V . Then*

$$(3.7) \quad \frac{1}{k!} \partial_{\zeta_1}^k \left(\zeta_{12}^N Y(a, \zeta_1) Y(b, \zeta_2) c \right) \Big|_{\zeta_1 = \zeta_2} = Y(a_{(N-1-k)} b, \zeta_2) c$$

for all $a, b \in V$, $c \in M$, $k \geq 0$, and sufficiently large N , where $\zeta_{12} = \zeta_1 - \zeta_2$. We can take $N = N_{ab}$ where N_{ab} is such that (3.6) holds.

Proof. Without loss of generality, we can suppose again that $\sigma a = e^{-2\pi\sqrt{-1}p}a$ with $p \in \frac{1}{h}\mathbb{Z}$; then (3.1) holds. Using properties of the formal delta function (3.4) and the formal residue (2.4), we find that the left-hand side of (3.7) is equal to

$$\begin{aligned} L &:= \frac{1}{k!} \text{Res}_{\zeta_1} \zeta_1^p \zeta_2^{-p} \delta(\zeta_1, \zeta_2) \partial_{\zeta_1}^k (\zeta_{12}^{N_{ab}} Y(a, \zeta_1) Y(b, \zeta_2) c) \\ &= \frac{1}{k!} \text{Res}_{\zeta_1} (-\partial_{\zeta_1})^k (\zeta_1^p \zeta_2^{-p} \delta(\zeta_1, \zeta_2)) \zeta_{12}^{N_{ab}} Y(a, \zeta_1) Y(b, \zeta_2) c. \end{aligned}$$

By the Leibniz rule and (3.4), we have

$$\frac{1}{k!} (-\partial_{\zeta_1})^k (\zeta_1^p \zeta_2^{-p} \delta(\zeta_1, \zeta_2)) = \sum_{i=0}^k (-1)^i \binom{p}{i} \zeta_1^{p-i} \zeta_2^{-p} (\iota_{\zeta_1, \zeta_2} - \iota_{\zeta_2, \zeta_1}) \zeta_{12}^{-1-k+i}.$$

Then Borchers identity (3.5), combined with locality (3.6), gives that

$$L = \sum_{i=0}^k (-1)^i \binom{p}{i} \text{Res}_{\zeta_{12}} Y(Y(a, \zeta_{12}) b, \zeta_2) c \iota_{\zeta_2, \zeta_{12}} \zeta_1^{p-i} \zeta_2^{-p} \zeta_{12}^{N_{ab}-1-k+i}.$$

Writing explicitly the expansion of $\zeta_1 = \zeta_2 + \zeta_{12}$ as in (3.3), and using (2.4), we obtain

$$L = \sum_{i=0}^k \sum_{j=0}^{\infty} (-1)^i \binom{p}{i} \binom{p-i}{j} \zeta_2^{-i-j} Y(Y(a_{(N_{ab}-1-k+i+j)} b, \zeta_2) c).$$

Notice that the sum over j can be truncated at $j = k - i$, because $a_{(n)} b = 0$ for $n \geq N_{ab}$. Setting $m = i + j$, we get

$$L = \sum_{m=0}^k \sum_{i=0}^m (-1)^i \binom{p}{i} \binom{p-i}{m-i} \zeta_2^{-m} Y(Y(a_{(N_{ab}-1-k+m)} b, \zeta_2) c).$$

Now observe that

$$\sum_{i=0}^m (-1)^i \binom{p}{i} \binom{p-i}{m-i} = \binom{p}{m} \sum_{i=0}^m (-1)^i \binom{m}{i} = \delta_{m,0},$$

completing the proof. \square

Remark 3.3. By reversing the above proof, one can show that, conversely, the product identity (3.7) and locality (3.6) imply the Borcherds identity (3.5). Therefore, they can replace the Borcherds identity in the definition of twisted representation.

Remark 3.4. The above proof simplifies significantly in the case of an untwisted representation M , as then $p = 0$. In the untwisted case, formula (3.7) first appeared in [7] and [5] for vertex algebras and generalized vertex algebras, respectively. It provides a rigorous interpretation of the *operator product expansion* in conformal field theory (cf. [61, 18]).

The following easy consequence of (3.7) will be useful later.

Corollary 3.5. *Assume that $a, b \in V$ and $c \in M$ are such that $Y(a, \zeta)c$ and $Y(b, \zeta)c$ have no negative powers of ζ . Then the same is true for all $Y(a_{(k)}b, \zeta)c$, $k \in \mathbb{Z}$.*

Proof. By locality (3.6), the product $\zeta_{12}^{N_{ab}} Y(a, \zeta_1)Y(b, \zeta_2)$ has no negative powers of ζ_1 and ζ_2 . Then use (3.7). \square

3.3. Twisted Heisenberg algebra. Let \mathfrak{h} be a finite-dimensional vector space equipped with a symmetric nondegenerate bilinear form $(\cdot|\cdot)$, as in Sect. 2.3. Then we have the Heisenberg algebra $\hat{\mathfrak{h}}$ and its highest weight representation, the Fock space \mathcal{F} , which has the structure of a vertex algebra. Every automorphism σ of \mathfrak{h} preserving the bilinear form induces automorphisms of $\hat{\mathfrak{h}}$ and \mathcal{F} , which will be denoted again as σ . As before, assume that σ has a finite order h .

The action of σ can be extended to $\mathfrak{h}[t^{1/h}, t^{-1/h}] \oplus \mathbb{C}K$ by letting

$$\sigma(at^m) = \sigma(a)e^{2\pi\sqrt{-1}m}t^m, \quad \sigma(K) = K, \quad a \in \mathfrak{h}, \quad m \in \frac{1}{h}\mathbb{Z}.$$

The σ -twisted Heisenberg algebra $\hat{\mathfrak{h}}_\sigma$ is defined as the set of all σ -invariant elements (see e.g. [68, 78, 51]). In other words, $\hat{\mathfrak{h}}_\sigma$ is spanned over \mathbb{C} by K and the elements $a_m = at^m$ such that $\sigma a = e^{-2\pi\sqrt{-1}m}a$. This is a Lie algebra with bracket (cf. (2.1))

$$[a_m, b_n] = m\delta_{m,-n}(a|b)K, \quad a, b \in \mathfrak{h}, \quad m, n \in \frac{1}{h}\mathbb{Z}.$$

Let $\hat{\mathfrak{h}}_\sigma^+$ (respectively, $\hat{\mathfrak{h}}_\sigma^-$) be the subalgebra of $\hat{\mathfrak{h}}_\sigma$ spanned by all elements a_m with $m \geq 0$ (respectively, $m < 0$). Elements of $\hat{\mathfrak{h}}_\sigma^+$ are called *annihilation operators*, while elements of $\hat{\mathfrak{h}}_\sigma^-$ *creation operators*.

The σ -twisted Fock space is defined as the generalized Verma module

$$(3.8) \quad \mathcal{F}_\sigma := \text{Ind}_{\hat{\mathfrak{h}}_\sigma^+ \oplus \mathbb{C}K}^{\hat{\mathfrak{h}}_\sigma} \mathbb{C} \cong S(\hat{\mathfrak{h}}_\sigma^-),$$

where $\hat{\mathfrak{h}}_\sigma^+$ acts on \mathbb{C} trivially and K acts as the identity operator. It is an irreducible highest weight representation of $\hat{\mathfrak{h}}_\sigma$. Moreover, \mathcal{F}_σ has the structure of a σ -twisted representation of the vertex algebra \mathcal{F} (see [52, 43, 25]). This structure can be described as follows. We let $Y(\mathbf{1}, \zeta)$ be the identity operator and

$$(3.9) \quad Y(a, \zeta) = \sum_{n \in p + \mathbb{Z}} a_n \zeta^{-n-1}, \quad a \in \mathfrak{h}, \quad \sigma a = e^{-2\pi\sqrt{-1}p} a,$$

where $p \in \frac{1}{h}\mathbb{Z}$ (cf. (3.1)). These satisfy the locality property (3.6) because

$$(3.10) \quad [Y(a, \zeta_1), Y(b, \zeta_2)] = (a|b) \partial_{\zeta_2} (\zeta_1^{-p} \zeta_2^p \delta(\zeta_1, \zeta_2)).$$

The action of Y on other elements of \mathcal{F} is then determined by applying several times the product formula (3.7).

3.4. Twisted representations of lattice vertex algebras. Now let $V = V_Q$ where Q is a root lattice of type X_N ($X = A, D, E$), and let σ be a *Coxeter element* of the corresponding Weyl group (see e.g. [12]). Such an element is a product of simple reflections $\sigma = r_{\alpha_1} \cdots r_{\alpha_N}$ where $\{\alpha_1, \dots, \alpha_N\}$ is a basis of simple roots and $r_\alpha(\beta) = \beta - (\alpha|\beta)\alpha$. All Coxeter elements are conjugate to each other; their order is the *Coxeter number* h . The element σ is diagonalizable on \mathfrak{h} with eigenvalues $e^{2\pi\sqrt{-1}m_k/h}$ where m_k are the exponents of \mathfrak{g} (see Table 1 in Sect. 4.2 below). In particular, σ has no fixed points in \mathfrak{h} .

Example 3.6. For type A_N , one Coxeter element acts as the cyclic permutation $v_1 \mapsto v_2 \mapsto \cdots \mapsto v_{N+1} \mapsto v_1$, in the notation of Example 2.4. For type D_N , in the notation of Example 2.5, one Coxeter element acts as $v_1 \mapsto v_2 \mapsto \cdots \mapsto v_{N-1} \mapsto -v_1, v_N \mapsto -v_N$.

For $\alpha, \beta \in Q$, we define

$$\varepsilon(\alpha, \beta) = (-1)^{L(\alpha, \beta)}, \quad L(\alpha, \beta) := ((1 - \sigma)^{-1} \alpha | \beta).$$

The bilinear form $L(\cdot, \cdot)$ is known in singularity theory as the *Seifert form*, and is integer valued (see e.g. [3, 32]). The bilinearity of L implies that ε is bimultiplicative and so it is a 2-cocycle. Using the σ -invariance of $(\cdot | \cdot)$, one easily checks that $|\alpha|^2 = 2L(\alpha, \alpha)$, which implies (2.6). Observe that ε is σ -invariant:

$$\varepsilon(\sigma\alpha, \sigma\beta) = \varepsilon(\alpha, \beta), \quad \alpha, \beta \in Q.$$

Then σ can be lifted to an automorphism of V_Q of order h :

$$\sigma(a_m) = \sigma(a)_m, \quad \sigma(e^\alpha) = e^{\sigma\alpha}, \quad a \in \mathfrak{h}, \quad \alpha \in Q.$$

Under the above simplifying assumptions, the σ -twisted Fock space \mathcal{F}_σ defined in (3.8) can be endowed with the structure of a σ -twisted representation of V_Q (see [68, 78, 23, 25, 4]). We define $Y(a, \zeta)$ as before (see (3.9)), and we let

$$(3.11) \quad Y(e^\alpha, \zeta) = U_\alpha \zeta^{-|\alpha|^2/2} : \exp \left(\sum_{n \in \frac{1}{h}\mathbb{Z} \setminus \{0\}} \alpha_n \frac{\zeta^{-n}}{-n} \right) :,$$

where U_α are certain nonzero complex numbers. As usual, the colons denote *normal ordering*, which means that we put all annihilation operators (α_n for $n > 0$) to the right of all creation operators (α_n for $n < 0$).

The scalars U_α satisfy

$$U_\alpha U_\beta = \varepsilon(\alpha, \beta) B_{\alpha, \beta}^{-1} U_{\alpha + \beta},$$

where

$$B_{\alpha, \beta} := h^{-(\alpha|\beta)} \prod_{k=1}^{h-1} (1 - e^{2\pi\sqrt{-1}k/h})^{(\sigma^k \alpha|\beta)}.$$

We will also need that the product $Y(e^\alpha, \zeta_1)Y(e^{-\alpha}, \zeta_2)$ on \mathcal{F}_σ is given by (see e.g. [4])

$$(3.12) \quad (-1)^{|\alpha|^2(|\alpha|^2+1)/2} \zeta_1^{-|\alpha|^2/2} \zeta_2^{-|\alpha|^2/2} \iota_{\zeta_1, \zeta_2} f_\alpha(\zeta_1, \zeta_2) E_\alpha(\zeta_1, \zeta_2),$$

where

$$f_\alpha(\zeta_1, \zeta_2) = B_{\alpha, \alpha} \prod_{k=0}^{h-1} (\zeta_1^{1/h} - e^{2\pi\sqrt{-1}k/h} \zeta_2^{1/h})^{-(\sigma^k \alpha|\alpha)},$$

and

$$E_\alpha(\zeta_1, \zeta_2) = : \exp \left(\sum_{n \in \frac{1}{h}\mathbb{Z} \setminus \{0\}} \frac{\alpha_n}{n} (\zeta_2^{-n} - \zeta_1^{-n}) \right) :.$$

3.5. Twisted representations of \mathcal{W}_{X_N} . We will now use the product formula (3.7) to compute the explicit action on \mathcal{F}_σ of the elements of \mathcal{W}_{X_N} given by (2.9) and (2.10). Introduce the *Faà di Bruno polynomials* (see Sect. 6A in [19]):

$$S_n(\alpha, \zeta) = \frac{1}{n!} (\partial_\zeta + \alpha(\zeta))^n \mathbf{1}, \quad \text{where } \alpha(\zeta) = Y(\alpha, \zeta), \quad \alpha \in \mathfrak{h}.$$

More explicitly,

$$S_n(\alpha, \zeta) = : S_n \left(\alpha(\zeta), \frac{1}{2!} \partial_\zeta \alpha(\zeta), \frac{1}{3!} \partial_\zeta^2 \alpha(\zeta), \dots \right) :,$$

where

$$S_n(x_1, x_2, x_3, \dots) = \sum_{\substack{i_1+2i_2+3i_3+\dots=n \\ i_s \in \mathbb{Z}_{\geq 0}}} \frac{x_1^{i_1} x_2^{i_2} x_3^{i_3} \dots}{i_1! i_2! i_3! \dots}$$

are the *elementary Schur polynomials*. When acting on the σ -twisted Fock space \mathcal{F}_σ , the coefficients of $S_n(\alpha, \zeta)$ in front of powers of ζ are represented by differential operators.

Lemma 3.7. *For every $d \geq 1$ and $\alpha \in \mathfrak{h}$ such that $|\alpha|^2 \in \mathbb{Z}$, we have*

$$Y(e^\alpha_{(-d)} e^{-\alpha}, \zeta) = (-1)^{|\alpha|^2(|\alpha|^2+1)/2} \sum_{k=0}^{|\alpha|^2-1+d} c_k^\alpha \zeta^{-k} S_{|\alpha|^2-1+d-k}(\alpha, \zeta)$$

when acting on \mathcal{F}_σ , where c_k^α is the coefficient in front of $(x-1)^k$ in the Taylor expansion of

$$B_{\alpha, \alpha} x^{-|\alpha|^2/2} \prod_{k=1}^{h-1} (x^{1/h} - e^{2\pi\sqrt{-1}k/h})^{((1-\sigma^k)\alpha|\alpha)}$$

around $x = 1$. In particular, $c_0^\alpha = 1$ and $c_k^\alpha = c_k^{-\alpha} = c_k^{\sigma\alpha}$.

Proof. We will apply (3.7) for $a = e^\alpha$, $b = e^{-\alpha}$ and $c \in \mathcal{F}_\sigma$. First, we observe that by (2.8)

$$Y(e^\alpha, \zeta) e^{-\alpha} = \varepsilon(\alpha, -\alpha) \zeta^{-|\alpha|^2} \exp\left(\sum_{n<0} \alpha_n \frac{\zeta^{-n}}{-n}\right) \mathbf{1},$$

so we can take $N_{ab} = |\alpha|^2$. Then on \mathcal{F}_σ the product $Y(e^\alpha, \zeta_1) Y(e^{-\alpha}, \zeta_2)$ is given by (3.12); and

$$\zeta_{12}^{|\alpha|^2} \iota_{\zeta_1, \zeta_2} f_\alpha(\zeta_1, \zeta_2) = B_{\alpha, \alpha} \prod_{k=1}^{h-1} (\zeta_1^{1/h} - e^{2\pi\sqrt{-1}k/h} \zeta_2^{1/h})^{((1-\sigma^k)\alpha|\alpha)}$$

is well defined for $\zeta_1 = \zeta_2$. Now the proof follows from the fact that

$$\frac{1}{n!} \partial_{\zeta_1}^n E_\alpha(\zeta_1, \zeta_2) \Big|_{\zeta_1=\zeta_2} = S_n(\alpha, \zeta_2)$$

(see e.g. [19, 66]). □

Lemma 3.8. *Let $a, b \in \mathfrak{h}$ be such that $\sigma a = e^{-2\pi\sqrt{-1}p} a$ with $p \in \frac{1}{h}\mathbb{Z}$, $0 < p < 1$. Then for every $d \geq 1$, we have*

$$Y(a_{(-d)} b, \zeta) = \frac{1}{(d-1)!} :(\partial_\zeta^{d-1} a(\zeta)) b(\zeta): - d \binom{-p+1}{d+1} (a|b) \zeta^{-d-1}$$

when acting on \mathcal{F}_σ , where $a(\zeta) = Y(a, \zeta)$.

Proof. We will apply (3.7) with $N_{ab} = 2$. It follows from (3.10), (3.9) and (3.4) that

$$(3.13) \quad a(\zeta_1)b(\zeta_2) = :a(\zeta_1)b(\zeta_2): + (a|b) \partial_{\zeta_2} \iota_{\zeta_1, \zeta_2} (\zeta_1^{-p} \zeta_2^p \zeta_{12}^{-1}).$$

The rest of the proof is straightforward, using (3.7). \square

4. SINGULARITIES: ROOT SYSTEMS AND FROBENIUS STRUCTURES

The marvelous interrelations between singularities and root systems were uncovered in the works of Klein, Du Val, Brieskorn, Looijenga, Arnold, Slodowy, Saito and others [14, 84, 2, 99, 94]. We will review only the material needed for the rest of the paper, referring to [3, 32, 63] for more details. Our main goal is to introduce the Frobenius structure on the space of miniversal deformations of a germ of a holomorphic function with an isolated critical point. We also introduce the period integrals, which are an important ingredient in our construction.

4.1. Milnor fibration. Let $f: (\mathbb{C}^{2l+1}, 0) \rightarrow (\mathbb{C}, 0)$ be the germ of a holomorphic function with an isolated critical point of multiplicity N . Denote by

$$H = \mathbb{C}[[x_0, \dots, x_{2l}]] / (\partial_{x_0} f, \dots, \partial_{x_{2l}} f)$$

the *local algebra* of the critical point; then $\dim H = N$.

Definition 4.1. A *miniversal deformation* of f is a germ of a holomorphic function $F: (\mathbb{C}^N \times \mathbb{C}^{2l+1}, 0) \rightarrow (\mathbb{C}, 0)$ satisfying the following two properties:

- (1) F is a deformation of f , i.e., $F(0, x) = f(x)$.
- (2) The partial derivatives $\partial F / \partial t^i$ ($1 \leq i \leq N$) project to a basis in the local algebra

$$\mathcal{O}_{\mathbb{C}^N, 0}[[x_0, \dots, x_{2l}]] / \langle \partial_{x_0} F, \dots, \partial_{x_{2l}} F \rangle.$$

Here we denote by $t = (t^1, \dots, t^N)$ and $x = (x_0, \dots, x_{2l})$ the standard coordinates on \mathbb{C}^N and \mathbb{C}^{2l+1} respectively, and $\mathcal{O}_{\mathbb{C}^N, 0}$ is the algebra of germs at 0 of holomorphic functions on \mathbb{C}^N .

We fix a representative of the holomorphic germ F , which we denote again by F , with a domain X constructed as follows. Let

$$B_\rho^{2l+1} \subset \mathbb{C}^{2l+1}, \quad B = B_\eta^N \subset \mathbb{C}^N, \quad B_\delta^1 \subset \mathbb{C}$$

be balls with centers at 0 and radii ρ, η , and δ , respectively. We set

$$S = B \times B_\delta^1 \subset \mathbb{C}^N \times \mathbb{C}, \quad X = (B \times B_\rho^{2l+1}) \cap \phi^{-1}(S) \subset \mathbb{C}^N \times \mathbb{C}^{2l+1},$$

where

$$\phi: B \times B_\rho^{2l+1} \rightarrow B \times \mathbb{C}, \quad (t, x) \mapsto (t, F(t, x)).$$

This map induces a map $\phi: X \rightarrow S$ and we denote by X_s or $X_{t,\lambda}$ the fiber

$$X_s = X_{t,\lambda} = \{(t, x) \in X \mid F(t, x) = \lambda\}, \quad s = (t, \lambda) \in S.$$

The number ρ is chosen so small that for all r , $0 < r \leq \rho$, the fiber $X_{0,0}$ intersects transversely the boundary ∂B_r^{2l+1} of the ball with radius r . Then we choose the numbers η and δ small enough so that for all $s \in S$ the fiber X_s intersects transversely the boundary ∂B_ρ^{2l+1} . Finally, we can assume without loss of generality that the critical values of F are contained in a disk $B_{\delta_0}^1$ with radius $\delta_0 < 1 < \delta$.

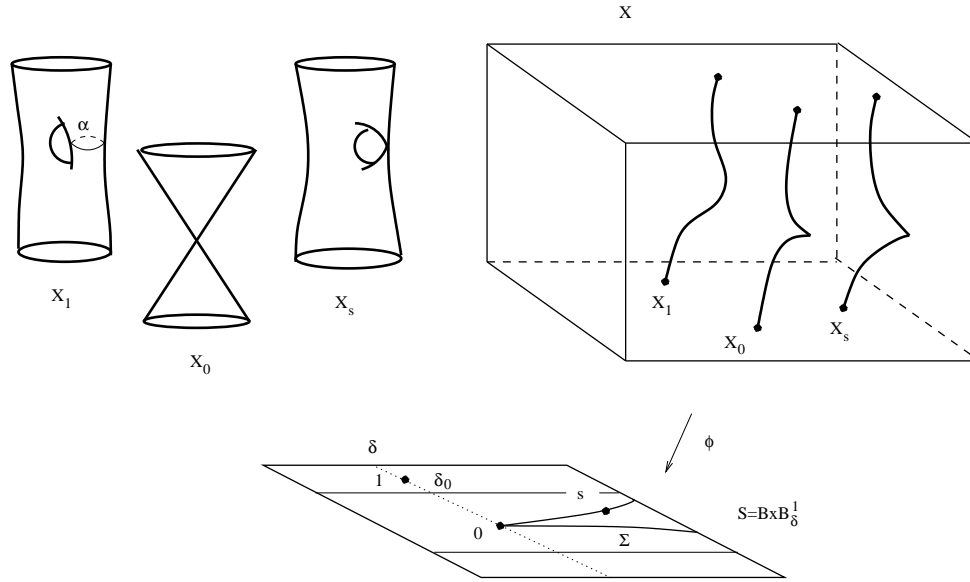

FIGURE 1. Milnor fibration

Let Σ be the *discriminant* of the map ϕ , i.e., the set of all points $s \in S$ such that the fiber X_s is singular. Put

$$S' = S \setminus \Sigma \subset \mathbb{C}^N \times \mathbb{C}, \quad X' = \phi^{-1}(S') \subset X \subset \mathbb{C}^N \times \mathbb{C}^{2l+1}.$$

Then the map $\phi: X' \rightarrow S'$ is a smooth fibration, called the *Milnor fibration*. In particular, all smooth fibers are diffeomorphic to $X_{0,1}$. The middle homology group of the smooth fiber, equipped with the bilinear form $(\cdot|\cdot)$ equal to $(-1)^l$ times the intersection form, is known as the *Milnor lattice* $Q = H_{2l}(X_{0,1}; \mathbb{Z})$.

For a generic point $s \in S$, the singularity of the fiber X_s is Morse. Thus, every choice of a path from $(0, 1)$ to s avoiding Σ leads to a group homomorphism $Q \rightarrow H_{2l}(X_s; \mathbb{Z})$. The kernel of this homomorphism is a free \mathbb{Z} -module of rank 1. A generator $\alpha \in Q$ of the kernel is called a

vanishing cycle if $(\alpha|\alpha) = 2$. We denote by R the set of all vanishing cycles for all possible choices of $s \in \Sigma$ and paths from $(0, 1)$ to s .

The fundamental group $\pi_1(S')$ of the base of the Milnor fibration acts on the homology of the smooth fiber $Q = H_{2l}(X_{0,1}; \mathbb{Z})$ preserving the intersection form. The image of $\pi_1(S')$ in $\text{Aut } Q$ will be called the *monodromy group* and denoted by W . The Picard–Lefschetz formula tells us that the monodromy associated to a small loop around a generic point $s \in \Sigma$ is given by the reflection r_α , where $\alpha \in R$ is a cycle vanishing over s and $r_\alpha(\beta) = \beta - (\alpha|\beta)\alpha$. Furthermore, W is generated by the reflections r_α ($\alpha \in R$). The so-called *classical monodromy* $\sigma \in W$ is the monodromy transformation corresponding to a big loop around Σ .

4.2. Simple singularities. The *simple* singularities are labeled by *ADE* Dynkin diagrams. In this case, we can take $f(x)$ to be a polynomial in three variables, as in Table 1. For further reference, we have also listed the *Coxeter number* h and the *exponents* $m_1 \leq \dots \leq m_N$ of the corresponding Lie algebra (see e.g. [12]).

TABLE 1. Simple singularities

Type	$f(x)$	Exponents	h
A_N	$x_0^{N+1} + x_1^2 + x_2^2$	$1, 2, \dots, N$	$N+1$
D_N	$x_0^{N-1} + x_0x_1^2 + x_2^2$	$1, 3, \dots, 2N-3, N-1$	$2N-2$
E_6	$x_0^4 + x_1^3 + x_2^2$	$1, 4, 5, 7, 8, 11$	12
E_7	$x_0^3x_1 + x_1^3 + x_2^2$	$1, 5, 7, 9, 11, 13, 17$	18
E_8	$x_0^5 + x_1^3 + x_2^2$	$1, 7, 11, 13, 17, 19, 23, 29$	30

For a simple singularity of type X_N ($X = A, D, E$), the Milnor lattice Q is isomorphic to a root lattice of type X_N , while the set R of vanishing cycles is a root system of type X_N . The monodromy group W coincides with the Weyl group, and the classical monodromy is a Coxeter element $\sigma \in W$.

4.3. Frobenius structure. Let \mathcal{T}_B be the sheaf of holomorphic vector fields on B . Condition (2) in Definition 4.1 implies that the map

$$\partial/\partial t^i \mapsto \partial F/\partial t^i \pmod{\langle \partial_{x_0} F, \dots, \partial_{x_{2l}} F \rangle} \quad (1 \leq i \leq N)$$

induces an isomorphism between \mathcal{T}_B and $p_*\mathcal{O}_C$, where $p: X \rightarrow B$ is the natural projection $(t, x) \mapsto t$ and

$$\mathcal{O}_C := \mathcal{O}_X / \langle \partial_{x_0} F, \dots, \partial_{x_{2l}} F \rangle$$

is the structure sheaf of the critical set of F . In particular, since \mathcal{O}_C is an algebra, the sheaf \mathcal{T}_B is equipped with an associative commutative

multiplication, which will be denoted by \bullet . It induces a product \bullet_t on the tangent space of every point $t \in B$. The class of the function F in \mathcal{O}_C defines a vector field $E \in \mathcal{T}_B$, called the *Euler vector field*.

Given a holomorphic volume form ω on $(\mathbb{C}^{2l+1}, 0)$, possibly depending on $t \in B$, we can equip $p_*\mathcal{O}_C$ with the so-called *residue pairing*:

$$(\psi_1(t, x), \psi_2(t, x)) := \left(\frac{1}{2\pi i}\right)^{2l+1} \int_{\Gamma_\epsilon} \frac{\psi_1(t, x) \psi_2(t, x)}{\partial_{x_0} F \cdots \partial_{x_{2l}} F} \omega,$$

where the integration cycle Γ_ϵ is supported on $|\partial_{x_0} F| = \cdots = |\partial_{x_{2l}} F| = \epsilon$. In particular, since $\mathcal{T}_B \cong p_*\mathcal{O}_C$, we get that the residue pairing induces a non-degenerate complex bilinear form $(\ , \)$ on \mathcal{T}_B .

For $t \in B$ and $z \in \mathbb{C}^*$, let $\mathcal{B}_{t,z}$ be a semi-infinite cycle in \mathbb{C}^{2l+1} of the following type:

$$\mathcal{B}_{t,z} \in \lim_{\rho \rightarrow \infty} H_{2l+1}(\mathbb{C}^{2l+1}, \{\operatorname{Re} z^{-1} F(t, x) < -\rho\}; \mathbb{C}) \cong \mathbb{C}^N.$$

The above homology groups form a vector bundle on $B \times \mathbb{C}^*$ equipped naturally with a Gauss–Manin connection, and $\mathcal{B} = \mathcal{B}_{t,z}$ may be viewed as a flat section. According to K. Saito’s theory of *primitive forms* [95, 96] there exists a form ω , called primitive, such that the oscillatory integrals (d^B is the de Rham differential on B)

$$J_{\mathcal{B}}(t, z) := (2\pi z)^{-l-\frac{1}{2}} (z d^B) \int_{\mathcal{B}_{t,z}} e^{z^{-1} F(t,x)} \omega \in \mathcal{T}_B^*$$

are horizontal sections for the following connection:

$$(4.1) \quad \nabla_{\partial/\partial t^i} = \nabla_{\partial/\partial t^i}^{\text{L.C.}} - z^{-1}(\partial_{t^i} \bullet_t), \quad 1 \leq i \leq N$$

$$(4.2) \quad \nabla_{\partial/\partial z} = \partial_z - z^{-1}\theta + z^{-2}E \bullet_t.$$

Here $\nabla^{\text{L.C.}}$ is the Levi–Civita connection associated with the residue pairing and

$$\theta := \nabla^{\text{L.C.}} E - \left(1 - \frac{d}{2}\right) \text{Id},$$

where d is some complex number.

In particular, this means that the residue pairing and the multiplication \bullet form a *Frobenius structure* on B of conformal dimension d with identity 1 and Euler vector field E . For the definition of a Frobenius structure we refer to [27, 86] (see also Sect. 1.2).

Example 4.2. For simple singularities, the standard volume form

$$\omega = dx_0 \wedge dx_1 \wedge \cdots \wedge dx_{2l}$$

is the only primitive form, up to a constant factor.

Assume that a primitive form ω is chosen. Note that the flatness of the Gauss–Manin connection implies that the residue pairing is flat. Denote by (τ^1, \dots, τ^N) a coordinate system on B that is flat with respect to the residue metric, and write ∂_i for the vector field $\partial/\partial\tau^i$. We can further modify the flat coordinate system so that the Euler field is the sum of a constant and linear fields:

$$E = \sum_{i=1}^N (1 - d_i) \tau^i \partial_i + \sum_{i=1}^N \rho_i \partial_i.$$

The constant part represents the class of f in H , and the spectrum of degrees d_1, \dots, d_N ranges from 0 to d . Note that in the flat coordinates τ^i the operator θ (called sometimes the *Hodge grading operator*) assumes diagonal form:

$$\theta(\partial_i) = \left(\frac{d}{2} - d_i\right) \partial_i, \quad 1 \leq i \leq N.$$

4.4. Period integrals. Given a middle homology class $\alpha \in H_{2l}(X_{0,1}; \mathbb{C})$, we denote by $\alpha_{t,\lambda}$ its parallel transport to the Milnor fiber $X_{t,\lambda}$. Let $d^{-1}\omega$ be any $2l$ -form whose differential is ω . We can integrate $d^{-1}\omega$ over $\alpha_{t,\lambda}$ and obtain multivalued functions of λ and t ramified around the discriminant in S (over which the Milnor fibers become singular).

Definition 4.3. To $\alpha \in \mathfrak{h} = H_{2l}(X_{0,1}; \mathbb{C})$, we associate the *period vectors* $I_\alpha^{(k)}(t, \lambda) \in H$ ($k \in \mathbb{Z}$) defined by

$$(4.3) \quad (I_\alpha^{(k)}(t, \lambda), \partial_i) := -(2\pi)^{-l} \partial_\lambda^{l+k} \partial_i \int_{\alpha_{t,\lambda}} d^{-1}\omega, \quad 1 \leq i \leq N.$$

Note that this definition is consistent with the operation of stabilization of singularities. Namely, adding the squares of two new variables does not change the right-hand side, since it is offset by an extra differentiation $(2\pi)^{-1} \partial_\lambda$. In particular, this defines the period vector for a negative value of $k \geq -l$ with l as large as one wishes. Note that, by definition, we have

$$\partial_\lambda I_\alpha^{(k)}(t, \lambda) = I_\alpha^{(k+1)}(t, \lambda), \quad \alpha \in \mathfrak{h}, \quad k \in \mathbb{Z}.$$

The following lemma is due to A. Givental [56].

Lemma 4.4. *The period vectors (4.3) satisfy the differential equations*

$$(4.4) \quad \partial_i I^{(k)} = -\partial_i \bullet_t (\partial_\lambda I^{(k)}), \quad 1 \leq i \leq N,$$

$$(4.5) \quad (\lambda - E \bullet_t) \partial_\lambda I^{(k)} = \left(\theta - k - \frac{1}{2}\right) I^{(k)}.$$

Using equation (4.5), we analytically extend the period vectors to all $|\lambda| > \delta$. It follows from (4.4) that the period vectors have the symmetry

$$(4.6) \quad I_\alpha^{(k)}(t, \lambda) = I_\alpha^{(k)}(t - \lambda \mathbf{1}, 0),$$

where $t \mapsto t - \lambda \mathbf{1}$ denotes the time- λ translation in the direction of the flat vector field $\mathbf{1}$ obtained from $1 \in H$. (The latter represents identity elements for all the products \bullet_t .)

An important consequence of Lemma 4.4 is the following formula due to K. Saito [95].

Corollary 4.5. *For all $\alpha, \beta \in H_{2l}(X_{0,1}; \mathbb{C})$, we have*

$$(\alpha|\beta) = -(I_\alpha^{(0)}(t, 0), E \bullet_t I_\beta^{(0)}(t, 0)).$$

Proof. According to Lemma 4.4, the right-hand side is independent of t . It is also monodromy invariant, therefore, up to a constant it must coincide with the intersection pairing. It remains only to verify that the proportionality coefficients is 1, which may be reduced to the case of an A_1 -singularity by letting t approach a generic point on the discriminant. \square

Now we will compute explicitly the period integrals $I_\alpha^{(k)}(0, \lambda)$ in the case of simple singularities. In this case, we may choose $l = 1$ and we can assign uniquely a degree χ_i to x_i , so that the polynomial $f(x)$ is *weighted homogeneous* of degree 1 (see Table 1 in Sect. 4.2). Furthermore, we can fix the flat coordinates in such a way that if we set $\deg \tau^i = 1 - d_i$ then $F(t, x)$ is still weighted homogeneous of degree 1. In particular, the polynomials $\partial_i F(t, x)$ are weighted homogeneous of degree d_i .

Then the integral (4.3) for $k = t = 0$ assumes the form

$$(4.7) \quad (I_\alpha^{(0)}(0, \lambda), \partial_i) = \lambda^{s_i} \langle v^i, \alpha \rangle,$$

where

$$s_i = d_i - \frac{d}{2} - \frac{1}{2}, \quad d = \sum_{i=0}^{2l} (1 - 2\chi_i) = 1 - \frac{2}{h},$$

and v^i are some constant sections of the middle cohomology bundle (see (4.8) below).

By definition, the analytic continuation in λ along a counter-clockwise loop around $\lambda = 0$ is equivalent to the parallel transport of α along that loop, i.e.,

$$e^{2\pi\sqrt{-1}s_i} \lambda^{s_i} \langle v^i, \alpha \rangle = \lambda^{s_i} \langle v^i, \sigma(\alpha) \rangle.$$

We obtain that v^i are eigenvectors of the classical monodromy σ , which according to Corollary 4.5 satisfy the following orthogonality relations:

$$\sigma(v^i) = e^{-2\pi\sqrt{-1}s_i}v^i, \quad (v^i|v^j) = (\partial_i, \partial_j).$$

In particular, $s_i = -m_i/h$, where m_i are the exponents of the corresponding simple Lie algebra. In other words, the period mapping

$$(4.8) \quad \partial_i \mapsto v^i := (2\pi)^{-l} \left(\partial_\lambda^l \int \partial_i F \frac{\omega}{dF} \right) \Big|_{(t,\lambda)=(0,1)}$$

is an isomorphism between the space of flat vector fields and \mathfrak{h}^* , i.e.,

$$\Gamma(B, \mathcal{T}_B)^\nabla \cong H^{2l}(X_{0,1}; \mathbb{C}),$$

which identifies the residue pairing with the intersection pairing.

4.5. Stationary phase asymptotic and calibration. Let $u_i(t)$ ($1 \leq i \leq N$) be the critical values of $F(t, \cdot)$. For a generic t , they form a local coordinate system on B in which the Frobenius multiplication and the residue pairing are diagonal. Namely,

$$\partial/\partial u_i \bullet_t \partial/\partial u_j = \delta_{ij} \partial/\partial u_j, \quad (\partial/\partial u_i, \partial/\partial u_j) = \delta_{ij} / \Delta_i,$$

where Δ_i is the Hessian of F with respect to the volume form ω at the critical point corresponding to the critical value u_i . Therefore, the Frobenius structure is *semi-simple*.

We denote by Ψ_t the following linear isomorphism

$$\Psi_t: \mathbb{C}^N \rightarrow T_t B, \quad e_i \mapsto \sqrt{\Delta_i} \partial/\partial u_i,$$

where $\{e_1, \dots, e_N\}$ is the standard basis for \mathbb{C}^N . Let U_t be the diagonal matrix with entries $u_1(t), \dots, u_N(t)$.

According to Givental [56], the system of differential equations (cf. (4.1), (4.2))

$$(4.9) \quad z \partial_i J(t, z) = \partial_i \bullet_t J(t, z), \quad 1 \leq i \leq N,$$

$$(4.10) \quad z \partial_z J(t, z) = (\theta - z^{-1} E \bullet_t) J(t, z)$$

has a unique formal asymptotic solution of the form $\Psi_t R_t(z) e^{U_t/z}$, where

$$R_t(z) = 1 + R_1(t)z + R_2(t)z^2 + \dots,$$

and $R_k(t)$ are linear operators on \mathbb{C}^N uniquely determined from the differential equations (4.9) and (4.10).

Introduce the formal series

$$(4.11) \quad \mathbf{f}_\alpha(t, \lambda, z) = \sum_{k \in \mathbb{Z}} I_\alpha^{(k)}(t, \lambda) (-z)^k, \quad \alpha \in \mathfrak{h}.$$

Then equations (4.4), (4.5) imply:

$$(4.12) \quad \partial_i \mathbf{f}_\alpha(t, \lambda, z) = -\partial_i \bullet_t (\partial_\lambda \mathbf{f}_\alpha(t, \lambda, z)), \quad 1 \leq i \leq N,$$

$$(4.13) \quad \lambda \partial_\lambda \mathbf{f}_\alpha(t, \lambda, z) = \left(-z \partial_z - z^{-1} E \bullet_t + \theta - \frac{1}{2} \right) \mathbf{f}_\alpha(t, \lambda, z).$$

The following result is due to Givental [58].

Proposition 4.6. *Let $t \in B$ be generic and β be a vanishing cycle vanishing over the point $(t, u_i(t)) \in \Sigma$. Then for all λ near $u_i(t)$, we have*

$$\mathbf{f}_\beta(t, \lambda, z) = \Psi_t R_t(z) \sum_{k \in \mathbb{Z}} (-z \partial_\lambda)^k \frac{2e_i}{\sqrt{2(\lambda - u_i(t))}}.$$

One can think of the connection operator in (4.1) as an isomonodromic family of connection operators ∇_t over $\mathbb{C} \setminus \{0\}$, parameterized by $t \in B$. We introduce a gauge transformation $\mathcal{S}_t(z)$ of the form

$$(4.14) \quad \mathcal{S}_t(z) = 1 + S_1(t)z^{-1} + S_2(t)z^{-2} + \dots, \quad S_k(t) \in \text{End } H$$

that satisfies the differential equations (4.9) and conjugates ∇_t and ∇_0 :

$$\nabla_t = \mathcal{S}_t \nabla_0 \mathcal{S}_t^{-1}, \quad \nabla_0 = \partial_z - z^{-1} \theta + z^{-2} \rho,$$

where $\rho = E \bullet_0$ is the constant part of the Euler vector field. In general, such a gauge transformation is not uniquely determined. However, it is not hard to see that if we impose the initial condition $\mathcal{S}_t(z)|_{t=0} = 1$ then such a gauge transformation exists and is unique.

Proposition 4.7. *We have $\mathcal{S}_t(z) \mathbf{f}_\alpha(0, \lambda, z) = \mathbf{f}_\alpha(t, \lambda, z)$ for λ in a neighborhood of ∞ .*

Proof. This follows from the differential equations (4.9), (4.12). \square

5. SYMPLECTIC LOOP SPACE FORMALISM

The goal of this section is to introduce Givental's quantization formalism (see [57]) and use it to define the higher genus potentials in singularity theory. We continue using the notation of Sect. 4.

5.1. Symplectic structure and quantization. As in Sect. 4, let H be the space of flat vector fields on B . The space $\mathcal{H} := H((z^{-1}))$ of formal Laurent series in z^{-1} with coefficients in H is equipped with the following *symplectic form*:

$$\Omega(\phi_1, \phi_2) := \text{Res}_z (\phi_1(-z), \phi_2(z)), \quad \phi_1, \phi_2 \in \mathcal{H},$$

where, as before, $(,)$ denotes the residue pairing on H and the formal residue Res_z gives the coefficient in front of z^{-1} .

Let $\{\partial_i\}_{i=1}^N$ and $\{\partial^i\}_{i=1}^N$ be dual bases of H with respect to the residue pairing. Then

$$\Omega(\partial^i(-z)^{-k-1}, \partial_j z^l) = \delta_{ij} \delta_{kl}.$$

Hence, a Darboux coordinate system is provided by the linear functions $q_k^i, p_{k,i}$ on \mathcal{H} given by:

$$q_k^i = \Omega(\partial^i(-z)^{-k-1}, \cdot), \quad p_{k,i} = \Omega(\cdot, \partial_i z^k).$$

In other words,

$$\phi(z) = \sum_{k=0}^{\infty} \sum_{i=1}^N q_k^i(\phi) \partial_i z^k + \sum_{k=0}^{\infty} \sum_{i=1}^N p_{k,i}(\phi) \partial^i(-z)^{-k-1}, \quad \phi \in \mathcal{H}.$$

The first of the above sums will be denoted $\phi(z)_+$ and the second $\phi(z)_-$.

The *quantization* of linear functions on \mathcal{H} is given by the rules:

$$\widehat{q}_k^i = \hbar^{-1/2} q_k^i, \quad \widehat{p}_{k,i} = \hbar^{1/2} \frac{\partial}{\partial q_k^i}.$$

Here and further, \hbar is a formal variable. We will denote by \mathbb{C}_\hbar the field $\mathbb{C}((\hbar^{1/2}))$.

Every $\phi(z) \in \mathcal{H}$ gives rise to the linear function $\Omega(\phi, \cdot)$ on \mathcal{H} , so we can define the quantization $\widehat{\phi}$. Explicitly,

$$(5.1) \quad \widehat{\phi} = -\hbar^{1/2} \sum_{k=0}^{\infty} \sum_{i=1}^N q_k^i(\phi) \frac{\partial}{\partial q_k^i} + \hbar^{-1/2} \sum_{k=0}^{\infty} \sum_{i=1}^N p_{k,i}(\phi) q_k^i.$$

The above formula makes sense also for $\phi(z) \in H[[z, z^{-1}]]$ if we interpret $\widehat{\phi}$ as a formal differential operator in the variables q_k^i with coefficients in \mathbb{C}_\hbar .

Lemma 5.1. *For all $\phi_1, \phi_2 \in \mathcal{H}$, we have $[\widehat{\phi}_1, \widehat{\phi}_2] = \Omega(\phi_1, \phi_2)$.*

Proof. It is enough to check this for the basis vectors $\partial^i(-z)^{-k-1}, \partial_i z^k$, in which case it is true by definition. \square

5.2. Quantization of quadratic Hamiltonians. It is known that both series $\mathcal{S}_t(z)$ and

$$\mathcal{R}_t(z) := \Psi_t R_t(z) \Psi_t^{-1}$$

(see Sect. 4.5) are symplectic transformations. Moreover, they both have the form $e^{A(z)}$, where $A(z)$ is an infinitesimal symplectic transformation.

A linear operator $A(z)$ on $\mathcal{H} := H((z^{-1}))$ is infinitesimal symplectic if and only if the map $\phi \in \mathcal{H} \mapsto A\phi \in \mathcal{H}$ is a Hamiltonian vector field with a Hamiltonian given by the quadratic function $h_A(\phi) = \frac{1}{2} \Omega(A\phi, \phi)$. By

definition, the *quantization* of $e^{A(z)}$ is given by the differential operator $e^{\widehat{h}A}$, where the quadratic Hamiltonians are quantized according to the following rules:

$$(p_{k,i}p_{l,j})^\wedge = \hbar \frac{\partial^2}{\partial q_k^i \partial q_l^j}, \quad (p_{k,i}q_l^j)^\wedge = (q_l^j p_{k,i})^\wedge = q_l^j \frac{\partial}{\partial q_k^i}, \quad (q_k^i q_l^j)^\wedge = \frac{1}{\hbar} q_k^i q_l^j.$$

5.3. Total descendant potential. Let us make the following convention. Given a vector

$$\mathbf{q}(z) = \sum_{k=0}^{\infty} q_k z^k \in H[z], \quad q_k = \sum_{i=1}^N q_k^i \partial_i \in H,$$

its coefficients give rise to a vector sequence q_0, q_1, \dots . By definition, a *formal function* on $H[z]$, defined in the formal neighborhood of a given point $c(z) \in H[z]$, is a formal power series in $q_0 - c_0, q_1 - c_1, \dots$. Note that every operator acting on $H[z]$ continuously in the appropriate formal sense induces an operator acting on formal functions.

Example 5.2. The *Witten–Kontsevich tau-function* is the following generating series:

$$(5.2) \quad \mathcal{D}_{\text{pt}}(\hbar; Q(z)) = \exp \left(\sum_{g,n} \frac{1}{n!} \hbar^{g-1} \int_{\mathcal{M}_{g,n}} \prod_{i=1}^n (Q(\psi_i) + \psi_i) \right),$$

where Q_0, Q_1, \dots are formal variables, and ψ_i ($1 \leq i \leq n$) are the first Chern classes of the cotangent line bundles on $\mathcal{M}_{g,n}$ (see [103, 74]). It is interpreted as a formal function of $Q(z) = \sum_{k=0}^{\infty} Q_k z^k \in \mathbb{C}[z]$, defined in the formal neighborhood of $-z$. In other words, \mathcal{D}_{pt} is a formal power series in $Q_0, Q_1 + 1, Q_2, Q_3, \dots$ with coefficients in $\mathbb{C}(\hbar)$.

Let $t \in B$ be a *semi-simple* point, so that the critical values $u_i(t)$ ($1 \leq i \leq N$) of $F(t, \cdot)$ form a coordinate system. Recall also the flat coordinates $\tau = (\tau^1(t), \dots, \tau^N(t))$ of t . We now introduce the main object of our study.

Definition 5.3. The *total descendant potential* of a singularity of type X_N is the following formal function on $H[z]$ defined in the formal neighborhood of $\tau - \mathbf{1}z$:

$$(5.3) \quad \mathcal{D}_{X_N}(\mathbf{q}(z)) = e^{F^{(1)}(t)} \widehat{\mathcal{S}}_t^{-1} \widehat{\Psi}_t \widehat{R}_t e^{\widehat{U}_t/z} \prod_{i=1}^N \mathcal{D}_{\text{pt}}(\hbar \Delta_i; \sqrt{\Delta_i} Q^i(z)),$$

where the factor $F^{(1)}(t)$ (called the genus-1 potential) is chosen so that it makes the formula independent of t .

As we discussed in Sect. 1.2, equation (5.3) is Givental's formula, which we now take as a definition. Let us examine more carefully the quantized action of the operators in this formula.

5.4. The action of the asymptotical operator. The operator \widehat{U}_t/z is known to annihilate the Witten–Kontsevich tau-function. Therefore, $e^{\widehat{U}_t/z}$ is redundant and it can be dropped from the formula. By definition, $\widehat{\Psi}_t$ is the following change of variables:

$$\mathbf{q}(z) = \Psi_t \sum_{i=1}^N Q^i(z) e_i, \quad \text{i.e.,} \quad \sqrt{\Delta_i} Q_k^i = \sum_{j=1}^N (\partial_j u_i) q_k^j.$$

Put $\widehat{\mathcal{R}}_t = \widehat{\Psi}_t \widehat{R}_t \widehat{\Psi}_t^{-1}$ and

$${}^i \mathbf{q}(z) = \sum_{k=0}^{\infty} \sum_{j=1}^N q_k^j (\partial_j u_i) z^k.$$

Then the total descendant potential assumes the form:

$$(5.4) \quad \mathcal{D}_{X_N}(\mathbf{q}(z)) = e^{F^{(1)}(t)} \widehat{\mathcal{S}}_t^{-1} \mathcal{A}_t(\mathbf{q}(z)),$$

where

$$(5.5) \quad \mathcal{A}_t(\mathbf{q}(z)) = \widehat{\mathcal{R}}_t \prod_{i=1}^N \mathcal{D}_{\text{pt}}(\hbar \Delta_i; {}^i \mathbf{q}(z)) \in \mathbb{C}_\hbar[[q_0, q_1 + \mathbf{1}, q_2 \dots]]$$

is the so-called *total ancestor potential* of the singularity. As before, $\mathbb{C}_\hbar := \mathbb{C}((\hbar^{1/2}))$.

The action of the operator $\widehat{\mathcal{R}}_t$ on formal functions, whenever it makes sense, is given as follows.

Lemma 5.4 (Givental [57]). *We have*

$$\widehat{\mathcal{R}}_t F(\mathbf{q}) = \left(e^{\frac{\hbar}{2} V \partial^2} F(\mathbf{q}) \right) \Big|_{\mathbf{q} \mapsto \mathcal{R}_t^{-1} \mathbf{q}},$$

where $V \partial^2$ is the quadratic differential operator

$$V \partial^2 = \sum_{k,l=0}^{\infty} \sum_{i,j=1}^N (\partial^i, V_{kl} \partial^j) \frac{\partial^2}{\partial q_k^i \partial q_l^j}$$

whose coefficients V_{kl} are given by

$$\sum_{k,l=0}^{\infty} (-1)^{k+l} V_{kl}(t) z^k w^l = \frac{{}^T R_t(z) R_t(w) - 1}{z + w}$$

and ${}^T R_t(z)$ denotes the transpose of $R_t(z)$.

The substitution $\mathbf{q} \mapsto \mathcal{R}_t^{-1}\mathbf{q}$ can be written more explicitly as follows:

$$q_0 \mapsto q_0, \quad q_1 \mapsto \overline{R}_1(t)q_0 + q_1, \quad q_2 \mapsto \overline{R}_2(t)q_0 + \overline{R}_1(t)q_1 + q_2, \dots$$

where

$$\mathcal{R}_t^{-1}(z) = 1 + \overline{R}_1(t)z + \overline{R}_2(t)z^2 + \dots.$$

Note that this substitution is not a well-defined operation on the space of formal functions. This complication, however, is offset by a certain property of the Witten–Kontsevich tau-function, which we will now explain.

By definition, an *asymptotical function* is a formal function of the type:

$$\mathcal{A}(\mathbf{q}) = \exp\left(\sum_{g=0}^{\infty} F^{(g)}(\mathbf{q})\hbar^{g-1}\right).$$

Such a function is called *tame* if the following $(3g-3+r)$ -jet constraints are satisfied:

$$\left. \frac{\partial^r F^{(g)}}{\partial q_{k_1}^{i_1} \dots \partial q_{k_r}^{i_r}} \right|_{\mathbf{q}=0} = 0 \quad \text{if} \quad k_1 + \dots + k_r > 3g - 3 + r.$$

The Witten–Kontsevich tau-function (up to the shift $q_1 \mapsto q_1 + 1$) is tame for dimensional reasons, since $\dim \mathcal{M}_{g,r} = 3g - 3 + r$.

Due to Givental [57], the action of the operator $\widehat{\mathcal{R}}_t$ on tame functions is well defined. Moreover, the resulting series is also a tame asymptotical function. In particular, the total ancestor potential \mathcal{A}_t is a tame asymptotical function.

5.5. The action of the calibration. The quantized symplectic transformation $\widehat{\mathcal{S}}_t^{-1}$ acts on formal functions as follows.

Lemma 5.5 (Givental [57]). *We have*

$$(5.6) \quad \widehat{\mathcal{S}}_t^{-1} F(\mathbf{q}) = e^{\frac{1}{2\hbar}W\mathbf{q}^2} F((\mathcal{S}_t\mathbf{q})_+),$$

where $W\mathbf{q}^2$ is the quadratic form

$$W\mathbf{q}^2 = \sum_{k,l=0}^{\infty} (W_{kl}q_l, q_k)$$

whose coefficients are defined by

$$\sum_{k,l=0}^{\infty} W_{kl}(t)z^{-k}w^{-l} = \frac{{}^T\mathcal{S}_t(z)\mathcal{S}_t(w) - 1}{z^{-1} + w^{-1}}.$$

The + sign in (5.6) means truncation of all negative powers of z , i.e., in $F(\mathbf{q})$ we have to substitute (cf. (4.14)):

$$q_k \mapsto q_k + S_1(t)q_{k+1} + S_2(t)q_{k+2} + \cdots, \quad k = 0, 1, 2, \dots$$

This operation is well defined on the space of formal power series.

Lemma 5.6. *We have an isomorphism*

$$\widehat{\mathcal{S}}_t^{-1}: \mathbb{C}_h[[q_0, q_1 + \mathbf{1}, q_2, \dots]] \rightarrow \mathbb{C}_h[[q_0 - \tau, q_1 + \mathbf{1}, q_2, \dots]].$$

Proof. We only need to check that $S_1(t)\mathbf{1} = \tau(t)$, which can be proved as follows. Since $\mathcal{S}_t(z)$ satisfies the differential equations $z\partial_i\mathcal{S}_t = \partial_i\bullet_t\mathcal{S}_t$, by comparing the coefficients in front of z^0 , we get $\partial_i(S_1(t)\mathbf{1}) = \partial_i$. Hence, $S_1(t)\mathbf{1} = \tau$ up to additive constants. But the constants must be 0 because $S_1(0) = 0$, since $\mathcal{S}_t(z)|_{t=0} = 1$. \square

6. ANALYTIC CONTINUATION OF THE VERTEX ALGEBRA REPRESENTATION

In this section, we construct an analytic continuation of the representation of the vertex algebra \mathcal{F} on the twisted Fock space. More precisely, we will construct formal differential operators $X_t(a, \lambda)$ for $a \in \mathcal{F}$, whose coefficients are multivalued analytic functions of $(t, \lambda) \in (B \times \mathbb{C}) \setminus \Sigma$ branching along the discriminant Σ . These operators possess remarkable properties and will be crucial for the proof of our main theorem.

6.1. Twisted Fock space. As in Sect. 4.2, consider a simple singularity of type X_N ($X = A, D, E$) with a Milnor lattice $Q = H_{2l}(X_{0,1}; \mathbb{Z})$. Then Q is a root lattice of type X_N and the set $R \subset Q$ of vanishing cycles is the corresponding root system. The bilinear form $(\cdot|\cdot)$, equal $(-1)^l$ times the intersection form, is such that $|\alpha|^2 = (\alpha|\alpha) = 2$ for $\alpha \in R$. The monodromy group W coincides with the Weyl group, and the classical monodromy is a Coxeter element $\sigma \in W$.

Let $\{v_j\}_{j=1}^N$ be a basis for $\mathfrak{h} = \mathbb{C} \otimes_{\mathbb{Z}} Q = H_{2l}(X_{0,1}; \mathbb{C})$ consisting of eigenvectors of σ :

$$\sigma(v_j) = e^{2\pi\sqrt{-1}m_j/h}v_j, \quad j = 1, \dots, N$$

(see Table 1 in Sect. 4.2). Since $(\cdot|\cdot)$ is W -invariant, we have $(v_i|v_j) = 0$ unless $m_i + m_j = h$, which is equivalent to $i + j = N + 1$. Hence, the dual basis $\{v^j\}_{j=1}^N$ can be chosen $v^j = v_{N+1-j}$.

The σ -twisted Heisenberg algebra $\widehat{\mathfrak{h}}_\sigma$ from Sect. 3.3 has a basis $\{K, v_{j(k-m_j/h)}\}_{k \in \mathbb{Z}, 1 \leq j \leq N}$. Its irreducible highest weight representation,

the σ -twisted Fock space \mathcal{F}_σ can be identified with the space of polynomials in $v_{j(-k-m_j/h)}$ where $k = 0, 1, \dots$ and $1 \leq j \leq N$. We will slightly modify this representation. Introduce

$$(6.1) \quad \mathcal{F}_\hbar := \mathbb{C}_\hbar \otimes_{\mathbb{C}} \mathcal{F}_\sigma \cong \mathbb{C}_\hbar[\mathbf{q}] \quad \text{where} \quad \mathbf{q} = \{q_k^j\}_{k=0,1,2,\dots}^{j=1,\dots,N}.$$

Then $\hat{\mathfrak{h}}_\sigma$ acts on \mathcal{F}_\hbar as follows:

$$(6.2) \quad \begin{aligned} v_{j(-k-m_j/h)} &= \frac{\hbar^{-1/2} q_k^j}{(m_j/h)_k}, \\ v_{j(k+m_j/h)}^j &= (m_j/h)_{k+1} \hbar^{1/2} \frac{\partial}{\partial q_k^j}, \end{aligned}$$

for $k = 0, 1, 2, \dots$ and $1 \leq j \leq N$, where

$$(x)_k := x(x+1) \cdots (x+k-1), \quad (x)_0 := 1.$$

As in Sect. 3.3, \mathcal{F}_\hbar is a σ -twisted representation of the vertex algebra \mathcal{F} , with generating fields given by (3.9):

$$(6.3) \quad Y(v^j, \zeta) = \sum_{k \in \mathbb{Z}} v_{(k+m_j/h)}^j \zeta^{-k-1-m_j/h}.$$

6.2. Period representation. For $\alpha \in \mathfrak{h}$, we let

$$X_t(\alpha, \lambda) = \partial_\lambda \hat{\mathbf{f}}_\alpha(t, \lambda) = \partial_\lambda \hat{\mathbf{f}}_\alpha(t, \lambda)_+ + \partial_\lambda \hat{\mathbf{f}}_\alpha(t, \lambda)_-$$

be the quantization of $\partial_\lambda \mathbf{f}_\alpha(t, \lambda, z)$ (see (4.11) and Sect. 5.1). More explicitly, due to (5.1), we have:

$$(6.4) \quad \partial_\lambda \hat{\mathbf{f}}_\alpha(t, \lambda)_+ = \sum_{k=0}^{\infty} \sum_{i=1}^N (-1)^{k+1} (I_\alpha^{(k+1)}(t, \lambda), \partial^i) \hbar^{1/2} \frac{\partial}{\partial q_k^i},$$

$$(6.5) \quad \partial_\lambda \hat{\mathbf{f}}_\alpha(t, \lambda)_- = \sum_{k=0}^{\infty} \sum_{i=1}^N (I_\alpha^{(-k)}(t, \lambda), \partial_i) \hbar^{-1/2} q_k^i,$$

where $\{\partial^i\}$ and $\{\partial_i\}$ are dual bases for H with respect to the residue pairing $(,)$. Using the period isomorphism (4.8), we may further arrange, by changing the basis of flat vector fields if necessary, that $\partial_i = v^i$ and $\partial^i = v_i$. By (4.7), we get that near $\lambda = \infty$

$$(I_{v^j}^{(k+1)}(0, \lambda), \partial^i) = \delta_{ij} \partial_\lambda^{k+1} \lambda^{-m_j/h} = \delta_{ij} (-1)^{k+1} (m_j/h)_{k+1} \lambda^{-k-1-m_j/h}$$

and

$$(I_{v^j}^{(-k)}(0, \lambda), \partial_i) = \delta_{ij} \partial_\lambda^{-k} \lambda^{-1+m_j/h} = \frac{\delta_{ij} \lambda^{k-1+m_j/h}}{(m_j/h)_k}$$

for all $k \geq 0$. Comparing with (6.2), (6.3), we obtain the following.

Lemma 6.1. *For $\alpha \in \mathfrak{h}$ and λ close to ∞ , $X_0(\alpha, \lambda)$ coincides with $Y(\alpha, \lambda)$ acting on \mathcal{F}_\hbar .*

As a consequence, the coefficients of the Laurent expansions near $\lambda = \infty$ of $X_0(\alpha, \lambda)$ for $\alpha \in \mathfrak{h}$ satisfy the commutation relations of the σ -twisted Heisenberg algebra $\hat{\mathfrak{h}}_\sigma$. On the other hand, by Lemma 5.1, we have

$$[X_t(\alpha, \lambda), X_t(\beta, \mu)] = \Omega(\partial_\lambda \mathbf{f}_\alpha(t, \lambda, z), \partial_\mu \mathbf{f}_\beta(t, \mu, z)).$$

Since $\mathbf{f}_\alpha(t, \lambda, z) = \mathcal{S}_t(z)\mathbf{f}_\alpha(0, \lambda, z)$ and $\mathcal{S}_t(z)$ is a symplectic transformation, the above Lie bracket is independent of t . Let us denote by $Y_t^\infty(\alpha, \lambda)$ the Laurent series expansion of $X_t(\alpha, \lambda)$ near $\lambda = \infty$.

Corollary 6.2. *For all $t \in B$, the operator series $Y_t^\infty(\alpha, \lambda)$ generate a σ -twisted representation of the vertex algebra \mathcal{F} on \mathcal{F}_\hbar .*

Our next goal is to express the operator series $Y_t^\infty(a, \lambda)$, $a \in \mathcal{F}$ in terms of normally ordered products of the generating fields and certain functions, which we call propagators.

6.3. Propagators and normally ordered product. We define the *normally ordered product* of formal differential operators D_1, \dots, D_r in \mathfrak{q} by putting all partial derivatives to the right of all variables, and we use the notation $:D_1 \cdots D_r:$. By definition, $:D_1 \cdots D_r:$ remains the same if we permute the factors.

In order to define the propagators, let us look at the identity

$$Y_t^\infty(\alpha, \mu)Y_t^\infty(\beta, \lambda) = :Y_t^\infty(\alpha, \mu)Y_t^\infty(\beta, \lambda): + P_{\alpha, \beta}^\infty(t, \mu, \lambda),$$

where $\alpha, \beta \in \mathfrak{h}$ and $P_{\alpha, \beta}^\infty(t, \mu, \lambda)$ is the Laurent expansion at $\lambda = \infty$ and $\mu = \infty$ of the following series

$$(6.6) \quad [\partial_\mu \widehat{\mathbf{f}}_\alpha(t, \mu)_+, \partial_\lambda \widehat{\mathbf{f}}_\beta(t, \lambda)_-] = \sum_{k=0}^{\infty} (-1)^{k+1} (I_\alpha^{(k+1)}(t, \mu), I_\beta^{(-k)}(t, \lambda)).$$

Note that the above series is convergent in the formal μ^{-1} -adic topology.

Since $Y_t^\infty(\alpha, \mu)$ and $Y_t^\infty(\beta, \lambda)$ satisfy the commutation relations of the σ -twisted Heisenberg algebra (cf. (3.10)), we have

$$(\mu - \lambda)^2 P_{\alpha, \beta}^\infty(t, \mu, \lambda) \in \mathbb{C}_\hbar((\lambda^{-1}, \mu^{-1})).$$

This implies that

$$P_{\alpha, \beta}^\infty(t, \mu, \lambda) = \iota_{\mu, \lambda} \left((\alpha|\beta)(\mu - \lambda)^{-2} + \sum_{k=0}^{\infty} P_{\alpha, \beta}^{\infty, k}(t, \lambda)(\mu - \lambda)^k \right),$$

where $\iota_{\mu,\lambda}$ denotes the expansion for $|\mu| > |\lambda|$ (cf. (3.3)) and $P_{\alpha,\beta}^{\infty,k}(t, \lambda)$ are some formal Laurent series in λ^{-1} . The next result is reminiscent of the well-known Wick formula (see e.g. [66], Theorem 3.3).

Proposition 6.3. *For $a \in \mathcal{F}$ of the form*

$$a = \alpha_{(-k_1-1)}^1 \cdots \alpha_{(-k_r-1)}^r \mathbf{1}, \quad r \geq 1, \alpha^i \in \mathfrak{h}, k_i \geq 0,$$

we have

$$(6.7) \quad Y_t^\infty(a, \lambda) = \sum_J \left(\prod_{(i,j) \in J} \partial_\lambda^{(k_j)} P_{\alpha^i, \alpha^j}^{\infty, k_i}(t, \lambda) \right) : \left(\prod_{l \in J'} \partial_\lambda^{(k_l)} Y_t^\infty(\alpha^l, \lambda) \right) :,$$

where the sum is over all collections J of disjoint ordered pairs $(i_1, j_1), \dots, (i_s, j_s) \subset \{1, \dots, r\}$ such that $i_1 < \dots < i_s$ and $i_l < j_l$ for all l , and $J' = \{1, \dots, r\} \setminus \{i_1, \dots, i_s, j_1, \dots, j_s\}$.

In the above formula, $J = \emptyset$ is allowed, an empty product is considered equal to 1, and here and further we use the divided-powers notation $\partial_\lambda^{(k)} := \partial_\lambda^k / k!$.

Proof. Let us prove the proposition only for $r = 2$. The general case follows easily by induction on r . Put $\alpha^1 := \alpha$, $\alpha^2 := \beta$, $k_1 := k$, and $k_2 := 0$. By Proposition 3.2, we have for $v \in \mathcal{F}_\mathfrak{h}$

$$Y_t^\infty(\alpha_{(-k-1)}\beta, \lambda)v = \partial_\mu^{(k+2)} \left((\mu - \lambda)^2 Y_t^\infty(\alpha, \mu) Y_t^\infty(\beta, \lambda)v \right) \Big|_{\mu=\lambda}.$$

Using the expansion of $P_{\alpha,\beta}^\infty$ in the powers of $\mu - \lambda$, we get

$$: (\partial_\lambda^{(k)} Y_t^\infty(\alpha, \lambda)) Y_t^\infty(\beta, \lambda) : v + P_{\alpha,\beta}^{\infty,k}(t, \lambda)v,$$

as claimed. \square

Let $F_{\alpha^1, \dots, \alpha^r}(t, \lambda)$ be a *multivalued analytic* function of $(t, \lambda) \in (B \times \mathbb{C}) \setminus \Sigma$ depending on $\alpha^1, \dots, \alpha^r \in \mathfrak{h}$, i.e., this is a function holomorphic in a neighborhood of some reference point, say $(0, 1)$, which can be extended analytically along any path $C \subset (B \times \mathbb{C}) \setminus \Sigma$.

Definition 6.4. We say that a multivalued analytic function $F_{\alpha^1, \dots, \alpha^r}(t, \lambda)$ has *monodromy* W if its analytic continuation along a loop C is $F_{w\alpha^1, \dots, w\alpha^r}(t, \lambda)$ where $w \in W$ is the monodromy operator induced by C (see Sect. 4.1).

Note that by definition $X_t(\alpha, \lambda)$, $\alpha \in \mathfrak{h}$, is a formal differential operator whose coefficients are multivalued analytic functions with monodromy W . We will prove in Sect. 7 below the following theorem.

Theorem 6.5. *For all $\alpha, \beta \in \mathfrak{h}$ the Laurent series $P_{\alpha,\beta}^{\infty,k}(t, \lambda)$ are convergent and give rise to multivalued analytic functions $P_{\alpha,\beta}^k(t, \lambda)$ with monodromy W .*

We will show in Sect. 7 that, in fact, the series

$$(6.8) \quad P_{\alpha,\beta}(t, \lambda; \xi) = (\alpha|\beta)\xi^{-2} + P_{\alpha,\beta}^0(t, \lambda)\xi^0 + P_{\alpha,\beta}^1(t, \lambda)\xi^1 + \dots$$

is convergent for sufficiently small $|\xi| > 0$, but this will not be needed here. We call $P_{\alpha,\beta}(t, \lambda; \xi)$ the *propagator* from α to β .

Example 6.6. For $\alpha, \beta \in \mathfrak{h}$ such that $\sigma(\alpha) = e^{-2\pi\sqrt{-1}p}\alpha$ ($p \in \frac{1}{h}\mathbb{Z}$), we have

$$(6.9) \quad \begin{aligned} [\partial_\mu \widehat{\mathbf{f}}_\alpha(0, \mu)_+, \partial_\lambda \widehat{\mathbf{f}}_\beta(0, \lambda)_-] &= (\alpha|\beta) \partial_\lambda \iota_{\mu, \lambda} \frac{\lambda^p \mu^{-p}}{\mu - \lambda} \\ &= (\alpha|\beta) \sum_{k=0}^{\infty} (p+k) \lambda^{p+k-1} \mu^{-p-k-1}. \end{aligned}$$

This follows from Lemma 6.1 and (3.13) or, alternatively, from (6.6) and (4.7). For $|\mu| > |\lambda| > 0$, the above series converges to a multivalued analytic function of (λ, μ) with a pole of order at most 2 at $\mu = \lambda$.

Let us denote by ι_λ the Laurent expansion near $\lambda = \infty$. Formula (6.7) and Theorem 6.5 imply that

$$(6.10) \quad Y_t^\infty(a, \lambda) = \iota_\lambda X_t(a, \lambda), \quad a \in \mathcal{F},$$

where $X_t(a, \lambda)$ is a formal differential operator in \mathfrak{q} whose coefficients are polynomial expressions of the periods and the propagators. Namely, assuming the same notation and conventions as in Proposition 6.3, we have

$$(6.11) \quad X_t(a, \lambda) = \sum_J \left(\prod_{(i,j) \in J} \partial_\lambda^{(k_j)} P_{\alpha^i, \alpha^j}^{k_i}(t, \lambda) \right) : \left(\prod_{l \in J'} \partial_\lambda^{(k_l)} X_t(\alpha^l, \lambda) \right) :$$

Remark 6.7. The operators $X_t(a, \lambda)$ can be defined for all $a \in V_Q$, but this will not be needed here. In particular, $X_t(a, \lambda)$ for $a \in \mathfrak{h}$ and $a = e^\alpha$ ($\alpha \in R$) provide a realization of the basic representation of the affine Kac–Moody algebra $\widehat{\mathfrak{g}}$ (cf. [45]). The operators $X_t(e^\alpha, \lambda)$ are defined in terms of the so-called *vertex operators* (cf. (3.11)):

$$(6.12) \quad \Gamma_\alpha(t, \lambda) = : \exp \widehat{\mathbf{f}}_\alpha(t, \lambda) : = \exp(\widehat{\mathbf{f}}_\alpha(t, \lambda)_-) \exp(\widehat{\mathbf{f}}_\alpha(t, \lambda)_+).$$

6.4. Behavior near a critical point. Our next goal is to understand the behavior of $X_t(a, \lambda)$ near a generic point $(t, u_i(t))$ on the discriminant. We will write $u = u_i(t)$ for short, and will fix a cycle $\beta \in \mathfrak{h}$ vanishing over (t, u) . Denote by $\iota_{\lambda-u}$ the operation of Laurent expansion near $\lambda = u$, and let

$$Y_t^u(a, \lambda) := \iota_{\lambda-u} X_t(a, \lambda), \quad a \in \mathcal{F}.$$

The following properties of the propagators will be proved in Sect. 7 below.

Theorem 6.8. *The following statements hold:*

- (a) *If $(\alpha'|\beta) = (\alpha''|\beta) = 0$, then the Taylor coefficients $P_{\alpha',\alpha''}^k(t, \lambda)$ of the propagator are analytic near $\lambda = u$.*
- (b) *There exists $r_i(t) > 0$ such that for all $\alpha \in \mathfrak{h}$ the Laurent expansion of $P_{\alpha,\beta}(t, \lambda; \mu - \lambda)$ in the domain $r_i(t) > |\mu - u| > |\lambda - u| > 0$ is equal to*

$$(6.13) \quad \sum_{k=0}^{\infty} (-1)^{k+1} (\iota_{\mu-u} I_{\alpha}^{(k+1)}(t, \mu), \iota_{\lambda-u} I_{\beta}^{(-k)}(t, \lambda)).$$

Let $\mathcal{F}_{\beta} \subset \mathcal{F}$ be the vertex subalgebra generated by β . Then

$$(6.14) \quad \mathcal{F}_{\beta} \cong \mathbb{C}[\beta_{-1}, \beta_{-2}, \beta_{-3}, \dots]$$

is just the Fock space for the Heisenberg algebra $\widehat{\mathbb{C}\beta}$. Similarly, let

$$(6.15) \quad \mathcal{F}_{\beta}^{\perp} = \{a \in \mathcal{F} \mid \beta_{(n)}a = 0, \quad n \geq 0\}$$

be the Fock space for the Heisenberg algebra $(\widehat{\mathbb{C}\beta})^{\perp}$, which is a subalgebra of \mathcal{F} commuting with \mathcal{F}_{β} . Note that we have an isomorphism

$$(6.16) \quad \mathcal{F}_{\beta}^{\perp} \otimes \mathcal{F}_{\beta} \cong \mathcal{F}, \quad a \otimes b \mapsto a_{(-1)}b.$$

Recall that, by the Picard–Lefschetz formula (see Sect. 4.1), the monodromy operator associated to a small loop around (t, u) is the reflection $r_{\beta} \in W$.

Theorem 6.9. *The following statements hold:*

- (a) *For $a \in \mathcal{F}_{\beta}^{\perp}$, the coefficients of $X_t(a, \lambda)$ are holomorphic functions of (t, λ) in a neighborhood of (t, u) .*
- (b) *The map $b \in \mathcal{F}_{\beta} \mapsto Y_t^u(b, \lambda)$ is an r_{β} -twisted representation of the vertex algebra \mathcal{F}_{β} on $\mathcal{F}_{\mathfrak{h}}$.*
- (c) *For $a \in \mathcal{F}_{\beta}^{\perp}$, $b \in \mathcal{F}_{\beta}$, we have*

$$Y_t^u(a_{(-1)}b, \lambda) = Y_t^u(a, \lambda)Y_t^u(b, \lambda).$$

Proof. (a) If $\alpha \in \mathfrak{h}$ is such that $(\alpha|\beta) = 0$, the coefficients of $X_t(\alpha, \lambda)$ are invariant with respect to the local monodromy r_{β} , so they must be holomorphic functions of (t, λ) in a neighborhood of (t, u) . The statement for $a \in \mathcal{F}$ then follows from the definition (6.11) of $X_t(a, \lambda)$ and Theorem 6.8 (a).

(b) Note that

$$[Y_t^u(\beta, \mu), Y_t^u(\beta, \lambda)] = \iota_{\mu-u}\iota_{\lambda-u} \Omega(\partial_{\mu}\mathbf{f}^{A_1}(u, \mu, z), \partial_{\lambda}\mathbf{f}^{A_1}(u, \lambda, z)),$$

where we used Lemma 5.1 and Proposition 4.6 and we denoted by

$$(6.17) \quad \mathbf{f}^{A_1}(u, \lambda, z) = \pm 2 \sum_{k \in \mathbb{Z}} (-z\partial_{\lambda})^k (2(\lambda - u))^{-1/2}$$

the period series for an A_1 -singularity. It follows that the coefficients of $Y_t^u(\beta, \lambda)$ satisfy the r_β -twisted Heisenberg relations. Let us denote by

$$b \mapsto \tilde{Y}_t^u(b, \lambda), \quad b \in \mathcal{F}_\beta$$

the r_β -twisted representation generated by $Y_t^u(\beta, \lambda)$. By the same argument as in the proof of Proposition 6.3, we can express $\tilde{Y}_t^u(b, \lambda)$ in terms of the generating fields $Y_t^u(\beta, \lambda)$ and some propagators $P_{\beta, \beta}^{u, k}(t, \lambda)$. According to Theorem 6.8 (b), we have

$$P_{\beta, \beta}^{u, k}(t, \lambda) = \iota_{\lambda-u} P_{\beta, \beta}^k(t, \lambda),$$

which implies that

$$\tilde{Y}_t^u(b, \lambda) = \iota_{\lambda-u} X_t(b, \lambda) = Y_t^u(b, \lambda).$$

(c) We can assume that

$$\begin{aligned} a &= \alpha_{(-k_1-1)}^1 \cdots \alpha_{(-k_r-1)}^r \mathbf{1}, & r \geq 1, \alpha^i \in (\mathbb{C}\beta)^\perp, k_i \geq 0, \\ b &= \beta_{(-m_1-1)} \cdots \beta_{(-m_p-1)} \mathbf{1}, & p \geq 1, m_i \geq 0. \end{aligned}$$

Then, by (6.16),

$$a_{(-1)} b = \alpha_{(-k_1-1)}^1 \cdots \alpha_{(-k_r-1)}^r \beta_{(-m_1-1)} \cdots \beta_{(-m_p-1)} \mathbf{1}.$$

Using (6.11), one can express $Y_t^u(a, \lambda)$, $Y_t^u(b, \lambda)$ and $Y_t^u(a_{(-1)} b, \lambda)$ in terms of normally ordered products and propagators.

Then to compute $Y_t^u(a, \lambda) Y_t^u(b, \lambda)$, it is enough to compute all products of the type $A_{J'}(\lambda) B_{J''}(\lambda)$, where

$$A_{J'}(\lambda) = : \left(\prod_{i \in J'} \partial_\lambda^{(k_i)} Y_t^u(\alpha^i, \lambda) \right) :, \quad B_{J''}(\lambda) = : \left(\prod_{j \in J''} \partial_\lambda^{(m_j)} Y_t^u(\beta, \lambda) \right) :$$

for

$$J' \subset \{1, \dots, r\}, \quad J'' \subset \{1, \dots, p\}.$$

The product $A_{J'}(\lambda) B_{J''}(\lambda)$ is computed using the Wick formula (see e.g. [66], Theorem 3.3) and Theorem 6.8 (b):

$$A_{J'}(\lambda) B_{J''}(\lambda) = \sum_I \left(\prod_{(i, j) \in I} \partial_\lambda^{(m_j)} \iota_{\lambda-u} P_{\alpha^i, \beta}^{k_i}(t, \lambda) \right) C_I(\lambda).$$

Here the sum is over all collections I of disjoint ordered pairs (i, j) such that $i \in J'$, $j \in J''$, and

$$C_I(\lambda) = : \left(\prod_{l \in I'} \partial_\lambda^{(k_l)} Y_t^u(\alpha^l, \lambda) \prod_{n \in I''} \partial_\lambda^{(m_n)} Y_t^u(\beta, \lambda) \right) :,$$

where

$$I' = J' \setminus \{i \mid (i, j) \in I\}, \quad I'' = J'' \setminus \{j \mid (i, j) \in I\}.$$

It is not hard to see that the combinatorics of the Wick formula and formula (6.11) produce exactly the identity we claim. \square

Remark 6.10. It is not true that the Laurent expansions of all $X_t(a, \lambda)$ near $\lambda = u$ give a twisted representation of \mathcal{F} . Indeed, for $\alpha, \alpha' \in \mathfrak{h}$ such that $(\alpha|\beta) = (\alpha'|\beta) = 0$, the Laurent expansions of $X_t(\alpha, \lambda)$ and $X_t(\alpha', \lambda)$ have only non-negative powers of $\lambda - u$. Thus, they cannot satisfy the commutation relations of the Heisenberg algebra (cf. (3.10)).

6.5. Action on tame vectors. So far we have considered the action of $X_t(a, \lambda)$ on elements of \mathcal{F}_\hbar , i.e., on polynomials in \mathbf{q} (see (6.1)). Now we want to consider a certain completion of \mathcal{F}_\hbar . Note that for an arbitrary formal power series $v \in \mathbb{C}_\hbar[[\mathbf{q}]]$, the series $X_t(a, \lambda)v$ has divergent coefficients in general. We claim that if v is a tame asymptotical function (cf. Sect. 5.4), then $X_t(a, \lambda)v$ is a formal power series whose coefficients are formal Laurent series in $\hbar^{1/2}$ with coefficients finite linear combinations of the coefficients of $X_t(a, \lambda)$.

Using the natural multi-index notations, we can write

$$(6.18) \quad v(\hbar, \mathbf{q}) = \sum_{g, I} v_I^{(g)} \hbar^{g-1} \mathbf{q}^I, \quad I = \{i_k^l\}_{k=0,1,2,\dots}^{l=1,\dots,N}.$$

By definition, v is *tame* if $3g - 3 + \ell(I) < \ell_z(I)$ implies that $v_I^{(g)} = 0$, where

$$\ell(I) := \sum_{k=0}^{\infty} \sum_{l=1}^N i_k^l, \quad \ell_z(I) := \sum_{k=0}^{\infty} \sum_{l=1}^N k i_k^l.$$

If we write

$$(6.19) \quad X_t(a, \lambda) = \sum_{I, J} \hbar^{(\ell(J) - \ell(I))/2} a_{I, J}(t, \lambda) \mathbf{q}^I \partial_{\mathbf{q}}^J,$$

then $X_t(a, \lambda)v$ is a formal series of the type (6.18) whose coefficients $\tilde{v}_I^{(g)}$ are given by

$$\sum_{I', I'' : I' + I'' = I} \left(\sum_J C_J^{I', I''} a_{I', J}(t, \lambda) v_{I'' + J}^{(g'')} \right),$$

where

$$g'' + \frac{1}{2}(\ell(J) - \ell(I')) = g$$

and the precise values of the combinatorial coefficients $C_J^{I', I''} \in \mathbb{Z}$ are irrelevant. The first sum is always finite for a fixed I , while in the second one the non-zero terms are parameterized by J such that

$$3g'' - 3 + \ell(I'') + \ell(J) \geq \ell_z(I'') + \ell_z(J),$$

i.e.,

$$\frac{1}{2}\ell(J) + \ell_z(J) \leq 3g - 3 + \frac{3}{2}\ell(I') + \ell(I'') - \ell_z(I'').$$

For fixed g and I , there are only finitely many J satisfying the above inequality, which proves our claim.

Finally, let us point out that the formal composition of two operators $X_t(a, \mu)$ and $X_t(b, \lambda)$ is a formal differential operator whose coefficient in front of $\hbar^{\ell(J)-\ell(I)}/2 \mathbf{q}^I \partial_{\mathbf{q}}^J$ is

$$(6.20) \quad \sum_{I'+I''=I} \sum_{J'+J''=J} \left(\sum_K C_K^{I', I'', J', J''} a_{I', J'+K}(t, \mu) b_{I''+K, J''}(t, \lambda) \right)$$

for some $C_K^{I', I'', J', J''} \in \mathbb{Z}$. The first two sums are always finite for fixed I and J . However, the sum over K is infinite and so the product can be defined only if the series is convergent in an appropriate sense. As we saw in Sect. 6.3 and 6.4, this can be done if we use the Laurent series expansions at ∞ or $u = u_i(t)$.

Indeed, near ∞ , the sum over K in (6.20) is convergent in the μ^{-1} -adic topology, since $a_{I, J}(t, \mu) \rightarrow 0$ uniformly as $J \rightarrow \infty$. This is because $I_\alpha^{(k)}(t, \mu) \rightarrow 0$ as $k \rightarrow +\infty$.

Similarly, we will say that $b \in \mathcal{F}$ is *singular at $\lambda = u$* if $b_{I, J}(t, \lambda) \rightarrow 0$ uniformly in the $(\lambda - u)$ -adic topology as $I \rightarrow \infty$. Then (6.20) is convergent in the $(\lambda - u)$ -adic topology. By Theorem 6.9 (a) and Proposition 4.6, $\alpha \in \mathfrak{h} \subset \mathcal{F}$ is singular at $\lambda = u$ if and only if $\alpha \in \mathbb{C}\beta$, where β is a cycle vanishing over (t, u) . It follows from (6.11) and Theorem 6.8 (b) that all $b \in \mathcal{F}_\beta$ are singular at $\lambda = u$.

6.6. Intertwining operators. Recall that the calibration operator \mathcal{S}_t of the singularity gives an isomorphism between two different completions of the Fock space $\mathcal{F}_\hbar = \mathbb{C}_\hbar[\mathbf{q}]$ (see Sect. 5.5):

$$\widehat{\mathcal{S}}_t^{-1}: \mathbb{C}_\hbar[[q_0, q_1 + \mathbf{1}, q_2, \dots]] \rightarrow \mathbb{C}_\hbar[[q_0 - \tau, q_1 + \mathbf{1}, q_2, \dots]].$$

Using the operator series

$$Y(a, \lambda) = \iota_\lambda X_0(a, \lambda) = Y_0^\infty(a, \lambda), \quad a \in \mathcal{F},$$

we put the structure of a σ -twisted \mathcal{F} -module on the completion $\mathbb{C}_\hbar[[q_0 - \tau, q_1 + \mathbf{1}, q_2, \dots]]$. The other completion is equipped with the structure of a σ -twisted \mathcal{F} -module via the operator series $Y_t^\infty(a, \lambda)$, $a \in \mathcal{F}$.

Lemma 6.11. *The map $\widehat{\mathcal{S}}_t$ is a homomorphism of σ -twisted \mathcal{F} -modules, i.e.,*

$$Y_t^\infty(a, \lambda) = \widehat{\mathcal{S}}_t Y(a, \lambda) \widehat{\mathcal{S}}_t^{-1}, \quad a \in \mathcal{F}.$$

Proof. Using Lemma 5.5 and Proposition 4.7, we see that the above equation holds for all $a = \alpha \in \mathfrak{h} \subset \mathcal{F}$. Therefore, due to the construction via the Wick formula (see Proposition 6.3), it is enough to compare the propagators. The propagator of $\widehat{\mathcal{S}}_t Y(\alpha, \mu) \widehat{\mathcal{S}}_t^{-1}$ and $\widehat{\mathcal{S}}_t Y(\beta, \lambda) \widehat{\mathcal{S}}_t^{-1}$ is

$$\partial_\lambda \partial_\mu \Omega((\mathcal{S}_t(z) \mathbf{f}_\alpha(0, \mu, z))_+, (\mathcal{S}_t(z) \mathbf{f}_\beta(0, \lambda, z))_-).$$

By Proposition 4.7, this is precisely $P_{\alpha, \beta}^\infty(t, \mu, \lambda)$. \square

Now let $\mathcal{F}_h^{\text{tame}}$ be the space of *tame* series in $\mathbb{C}_h[[q_0, q_1 + \mathbf{1}, q_2, \dots]]$, as defined in Sect. 5.4 and 6.5. Then the asymptotical operator $\widehat{\Psi}_t \widehat{R}_t$ gives an injection (see Sect. 5.4)

$$(6.21) \quad \widehat{\Psi}_t \widehat{R}_t: \mathbb{C}_h[[Q_0, Q_1 + (1, \dots, 1), Q_2, \dots]]^{\text{tame}} \rightarrow \mathcal{F}_h^{\text{tame}}.$$

Let us assume that $t \in B$ is generic, λ is close to one of the critical values $u := u_i(t)$, and β is a cycle vanishing over (t, u) . By Theorem 6.9 (b), the space $\mathcal{F}_h^{\text{tame}}$ of tame vectors is an r_β -twisted \mathcal{F}_β -module.

On the other hand, applying our construction from Sect. 6.2 in the case of an A_1 -singularity, we get that the operator series

$$Y_u^{A_1}(\beta, \lambda) = \mathbf{f}^{A_1}(u, \lambda, z)^\wedge$$

(see (6.17)) induces the structure of an r_β -twisted \mathcal{F}_β -module on the space $\mathbb{C}_h[[Q_0^i, Q_1^i + 1, Q_2^i, \dots]]^{\text{tame}}$.

Lemma 6.12. *The operator (6.21) is a homomorphism of r_β -twisted \mathcal{F}_β -modules, i.e.,*

$$\widehat{\Psi}_t \widehat{R}_t Y_u^{A_1}(b, \lambda) = Y_t^u(b, \lambda) \widehat{\Psi}_t \widehat{R}_t, \quad b \in \mathcal{F}_\beta.$$

Proof. Due to Lemma 5.4 and Proposition 4.7, the above identity holds for $b = \beta$, which is the generator of \mathcal{F}_β . According to the Wick formula (see Proposition 6.3), it is enough to compare the propagators of the two modules. The propagator of $\widehat{\Psi}_t \widehat{R}_t Y_u^{A_1}(\beta, \mu) (\widehat{\Psi}_t \widehat{R}_t)^{-1}$ and $\widehat{\Psi}_t \widehat{R}_t Y_u^{A_1}(\beta, \lambda) (\widehat{\Psi}_t \widehat{R}_t)^{-1}$ is

$$\partial_\lambda \partial_\mu \Omega((\Psi_t R_t(z) \mathbf{f}^{A_1}(u, \mu, z))_+, (\Psi_t R_t(z) \mathbf{f}^{A_1}(u, \lambda, z))_-).$$

But

$$\Psi_t R_t(z) \mathbf{f}^{A_1}(u, \lambda, z) = \mathbf{f}_\beta(t, \lambda, z)$$

thanks to Proposition 4.6. \square

7. ANALYTIC CONTINUATION OF THE PROPAGATORS

The goal of this section is to prove Theorem 6.5 and Theorem 6.8. The idea is to express the phase factors via certain integrals. The latter were already used in [45], but we need to establish some further properties, which will allow us to extend analytically the phase factors and the corresponding propagators.

7.1. Integral representation of the phase factors. Let us denote by

$$\Gamma_\alpha^\infty(t, \lambda) = \iota_\lambda \Gamma_\alpha(t, \lambda), \quad \alpha \in Q,$$

the Laurent series expansion at $\lambda = \infty$ of the vertex operators (6.12). Due to Lemma 5.1, the product of two vertex operators is given by

$$(7.1) \quad \Gamma_\alpha^\infty(t, \mu) \Gamma_\beta^\infty(t, \lambda) = B_{\alpha, \beta}^\infty(t, \mu, \lambda) : \Gamma_\alpha^\infty(t, \mu) \Gamma_\beta^\infty(t, \lambda) :,$$

where

$$B_{\alpha, \beta}^\infty(t, \mu, \lambda) = \iota_\mu \iota_\lambda \exp \Omega(\mathbf{f}_\alpha(t, \mu, z)_+, \mathbf{f}_\beta(t, \lambda, z)_-)$$

is the so-called *phase factor*. Then, by definition (see (6.6)),

$$P_{\alpha, \beta}^\infty(t, \mu, \lambda) = \partial_\mu \partial_\lambda \log B_{\alpha, \beta}^\infty(t, \mu, \lambda).$$

The goal in this section will be to prove Theorem 6.5. In fact, we will prove a slightly stronger statement, namely that the phase factors are multivalued analytic functions with monodromy W .

We will make use of line integrals in B , whose integrands are 1-forms defined in terms of the period vectors $I_\alpha^{(k)}(t, \lambda)$. It is convenient to embed $B \subset B \times \mathbb{C}$, $t \mapsto (t, 0)$ and restrict the Milnor fibration and the corresponding middle homology bundle to B . The restriction of the discriminant $\Sigma \subset B \times \mathbb{C}$ to B will be called again the discriminant and its complement in B will be denoted by B' . In particular, the period vectors

$$(7.2) \quad I_\alpha^{(k)}(t, \lambda) = I_\alpha^{(k)}(t - \lambda \mathbf{1}, 0)$$

may be singular only at points (t, λ) such that $t - \lambda \mathbf{1}$ belongs to the discriminant.

Using the differential equations from Lemma 4.4, we get

$$(7.3) \quad d^B \Omega(\mathbf{f}_\alpha(t, \mu, z)_+, \mathbf{f}_\beta(t, \lambda, z)_-) = I_\alpha^{(0)}(t, \mu) \bullet_t I_\beta^{(0)}(t, \lambda),$$

where d^B denotes the de Rham differential on B . Motivated by this identity, let us consider the following family of improper integrals depending on parameters t, λ , and ξ :

$$(7.4) \quad B_{\alpha,\beta}(t, \lambda; \xi) = \lim_{\varepsilon \rightarrow 0} \exp \left(\int_{-\varepsilon \mathbf{1}}^{t-\lambda \mathbf{1}} I_{\alpha}^{(0)}(t', \xi) \bullet_{t'} I_{\beta}^{(0)}(t', 0) \right),$$

where the integration is along a path $C: [0, 1] \rightarrow B$, such that the strip

$$C_{\xi}: [0, 1] \times [0, 1] \rightarrow B, \quad C_{\xi}(s_1, s_2) = C(s_1) - s_2 \xi \mathbf{1}$$

does not intersect the discriminant. A path C with this property will be called a ξ -*path*. The integrand is a multivalued 1-form. In order to specify its values along the strip C_{ξ} , it is enough to assume that the integration path passes through a reference point, say $-\mathbf{1} \in B$, where the branches of the periods are fixed in advance. Note that for given $(t, \lambda) \notin \Sigma$, the integral in (7.4) is well defined for all sufficiently small ξ .

Using the translation invariance of the periods (see (7.2)) and the fact that $\mathbf{f}_{\beta}(t, \lambda, z)_-$ vanishes at $t = \lambda \mathbf{1}$, we get

$$(7.5) \quad B_{\alpha,\beta}^{\infty}(t, \mu, \lambda) = \iota_{\lambda} \iota_{\mu, \lambda} B_{\alpha,\beta}(t, \lambda; \mu - \lambda),$$

where $\iota_{\mu, \lambda}$ is the Laurent series expansion in the region $|\mu| > |\lambda| \gg 0$. In particular, the limit in (7.4) exists. Indeed, let us split the integration path in (7.4) into two parts (see parts *I* and *II* in Fig. 2 below):

$$\int_{-\varepsilon \mathbf{1}}^{-\lambda \mathbf{1}} + \int_{-\lambda \mathbf{1}}^{t-\lambda \mathbf{1}}.$$

The second integral depends holomorphically on λ and ξ , because the integration path and the corresponding ξ -strip do not intersect the discriminant, which means that the integrand is analytic.

The first integral is by (7.3) the logarithm of the phase factor for the product of $\Gamma_{\alpha}^{\infty}(0, \mu)$ and $\Gamma_{\beta}^{\infty}(0, \lambda)$, where $\mu = \lambda + \xi$. Recall from Remark 6.7 that these vertex operators provide the principal realization of the affine Lie algebra (see [45]). It is an easy exercise to compute these phase factors explicitly (see e.g. [4, 45] and Sect. 3.4). The answer is

$$(7.6) \quad B_{\alpha,\beta}^{\infty}(0, \mu, \lambda) = \prod_{k=0}^{h-1} \left(\mu^{1/h} - e^{2\pi\sqrt{-1}k/h} \lambda^{1/h} \right)^{(\sigma^k \alpha | \beta)}.$$

As in the proof of Lemma 3.7, one can see that for $\mu = \lambda + \xi$ the above function has the form

$$(7.7) \quad \xi^{(\alpha|\beta)} (1 + \dots),$$

where the dots stand for some function that depends analytically on ξ .

Now to prove Theorem 6.5, it is enough to set

$$P_{\alpha,\beta}(t, \lambda; \mu - \lambda) = \partial_\lambda \partial_\mu \log B_{\alpha,\beta}(t, \lambda; \mu - \lambda);$$

then the integral (7.4) provides an analytic continuation in (t, λ) along any path avoiding the discriminant, while formula (7.7) implies that the propagator has the required expansion (6.8). It remains only to prove that the phase factors have monodromy W , i.e., if $C \subset B$ is a closed loop based at $t - \lambda \mathbf{1}$ (avoiding the discriminant) and $w \in W$ is the corresponding monodromy transformation (on vanishing homology) then the analytic continuation of $B_{\alpha,\beta}(t, \lambda; \xi)$ along C is the same as $B_{w\alpha, w\beta}(t, \lambda; \xi)$.

Lemma 7.1. *Assume that $B_{\alpha,\beta}(t, \lambda; \xi)$ is invariant under the analytic continuation along any loop C such that the corresponding monodromy transformation w leaves both α and β invariant. Then $B_{\alpha,\beta}(t, \lambda; \xi)$ has monodromy W .*

Proof. Let $w \in W$ be any monodromy transformation. We may assume that the path in the definition of the phase factor (7.4) passes through a point $t_0 - \lambda_0 \mathbf{1}$ such that λ_0 is sufficiently large. Then

$$B_{\alpha,\beta}(t, \lambda; \xi) = A_{C_2}(B_{\alpha,\beta}(t_0, \lambda_0; \xi)),$$

where C_2 is the portion of the path from $t_0 - \lambda_0 \mathbf{1}$ to $t - \lambda \mathbf{1}$ and A_{C_2} denotes analytic continuation along C_2 . If C_0 is a loop based at $t_0 - \lambda_0 \mathbf{1}$ such that the corresponding monodromy transformation is w , then

$$(7.8) \quad A_{C_0}(B_{\alpha,\beta}(t_0, \lambda_0; \xi)) = B_{w\alpha, w\beta}(t_0, \lambda_0; \xi),$$

because both sides are given by an integral whose Laurent series expansion $\iota_{\lambda_0} \iota_{\mu_0, \lambda_0}$ with $\mu_0 = \xi + \lambda_0$ is $B_{w\alpha, w\beta}^\infty(t_0, \mu_0, \lambda_0)$.

Now let C_1 be a loop based at $t - \lambda \mathbf{1}$ whose monodromy transformation is w ; then

$$\frac{A_{C_1}(B_{\alpha,\beta}(t, \lambda; \xi))}{B_{w\alpha, w\beta}(t, \lambda; \xi)} = \frac{A_{C_1 \circ C_2}(B_{\alpha,\beta}(t_0, \lambda_0; \xi))}{A_{C_2}(B_{w\alpha, w\beta}(t_0, \lambda_0; \xi))}.$$

Using (7.8), we get that the above ratio is precisely

$$\exp \left(\oint_C I_\alpha^{(0)}(t', \xi) \bullet_{t'} I_\beta^{(0)}(t', 0) \right) = \frac{A_C(B_{\alpha,\beta}(t_0, \lambda_0; \xi))}{B_{\alpha,\beta}(t_0, \lambda_0; \xi)},$$

where

$$C = C_0^{-1} \circ C_2^{-1} \circ C_1 \circ C_2.$$

Both α and β are fixed by the monodromy transformation along C ; hence the above ratio is equal to 1. \square

Therefore, we need to prove that the phase factors satisfy the condition in Lemma 7.1. The proof follows essentially the ideas of Givental [58] and consists of two steps, which are formulated in the next two lemmas.

Lemma 7.2. *If C is a small ξ -loop that goes twice around a generic point on the discriminant, then*

$$\oint_C I_\alpha^{(0)}(t', \xi) \bullet_{t'} I_\beta^{(0)}(t', 0)$$

is an integer multiple of $2\pi\sqrt{-1}$.

Proof. For homotopy reasons, we may assume that C lies on the complex line through the generic point t_0 on the discriminant parallel to $\mathbf{C1}$. Then the integral can be written as

$$(7.9) \quad \oint_C (I_\alpha^{(0)}(t_0, \xi - u), I_\beta^{(0)}(t_0, -u)) du,$$

where $u = u_i(t)$ is the critical value that gives locally near t_0 the equation of the discriminant: $u(t) = 0$.

If α is invariant with respect to the local monodromy around t_0 , then $I_\alpha^{(0)}(t', \xi)$ is analytic for all t' sufficiently close to t_0 and the integral vanishes identically. The same also applies to β . Decomposing α and β into invariant and anti-invariant cycles with respect to the local monodromy, we get

$$\alpha = \alpha' + (\alpha|\gamma)\gamma/2, \quad \beta = \beta' + (\beta|\gamma)\gamma/2,$$

where γ is the cycle vanishing over t_0 . Since only the anti-invariant parts contribute to the integral, we may assume that $\alpha = \beta = \gamma$ are vanishing over t_0 and will have to prove that the integral is an integer multiple of $8\pi\sqrt{-1}$.

In this case, the period $I_\beta^{(0)}(t_0, \xi - u)$ has the following expansion:

$$I_\beta^{(0)}(t_0, \xi - u) = \Psi_{t_0} \sum_{k=0}^{\infty} R_k(t_0) \partial_\xi^{-k} I_{A_1}^{(0)}(u, \xi) e_i$$

(see Sect. 4.5), where

$$I_{A_1}^{(0)}(u, \xi) = \frac{\pm 2}{\sqrt{2(\xi - u)}}$$

is the period of A_1 -singularity. Substituting this expansion in formula (7.9) and using that Ψ_{t_0} is an isometry, we obtain

$$\sum_{k,l=0}^{\infty} \oint_C (R_k(t_0)(-\partial_u)^{-k} I_{A_1}^{(0)}(u, \xi), R_l(t_0)(-\partial_u)^{-l} I_{A_1}^{(0)}(u, 0)) du.$$

Since $R_{t_0}(z)$ is a symplectic transformation, we have

$$\sum_{k+l=n} (-1)^k {}^T R_l(t_0) R_k(t_0) = \delta_{n,0}.$$

Using integration by parts, we find that only the terms with $k = l = 0$ contribute to the integral, i.e., we get

$$\oint_C (I_{A_1}^{(0)}(u, \xi), I_{A_1}^{(0)}(u, 0)) du.$$

The argument is in fact slightly more subtle, because $R_t(z)$ is in general a divergent power series. The integral operator $\sum_{k \geq n} R_k(t_0) (-\partial_u)^{-k}$, however, when applied to the period $I_{A_1}^{(0)}(u, \xi)$ produces a convergent series and increases the order of the zero at $u = \xi$ by n . Therefore, by induction on n we see that modulo the term with $k = l = 0$ the remaining part of the integrand has an infinite order of vanishing at $u = \xi$, so it must be 0.

It remains only to compute the integral

$$\oint_C \frac{2}{\sqrt{(\xi - u)(-u)}} du,$$

where C is a closed contour going twice around $u = 0$ and $u = \xi$. The integral is easily seen to be $\pm 8\pi\sqrt{-1}$, which completes the proof. \square

Lemma 7.3. *Assume that C is a ξ -loop in B' such that the cycles α and β are invariant under the parallel transport along C . Then*

$$\oint_C I_\alpha^{(0)}(t', \xi) \bullet_{t'} I_\beta^{(0)}(t', 0)$$

is an integer multiple of $2\pi\sqrt{-1}$.

Proof. Since the monodromy group is a finite reflection group, any monodromy transformation w that fixes α and β can be written as a composition of reflections with respect to hyperplanes containing both α and β (see [12], Chapter V, Section 3.3, Proposition 2). On the other hand, the monodromy group is the quotient of the Artin–Brieskorn braid group $\pi_1(B')$ by the normal subgroup generated by the loops going twice around generic points on the discriminant (see [3, 32]).

It follows that our path C is homotopic to the composition of several paths C'_i along which α and β are invariant, and several paths C''_j that are simple loops going twice around generic points on the discriminant. Clearly, we may choose C'_i and C''_j to be ξ -loops.

The integral over C can be written as a sum of integrals over the loops C'_i and C''_j . Since both periods are invariant along C'_i , they must be holomorphic in a disk containing C'_i , which implies that the integrals

along C'_i vanish. By Lemma 7.2, the integrals along C''_j contribute only integer multiples of $2\pi\sqrt{-1}$, which completes the proof. \square

7.2. The phase factors near a critical value. Let us assume now that $t_0 \in B$ is a generic point on the discriminant and that the phase factor $B_{\alpha,\beta}(t, \lambda; \mu - \lambda)$ is analytically extended along some path for (t, λ, μ) such that $t - \lambda \mathbf{1}$ is close to t_0 and β coincides with the cycle vanishing over t_0 . The critical values $(u_1(t), \dots, u_N(t))$ of $F(t, \cdot)$ form a coordinate system for t near t_0 and the local equation of the discriminant has the form $\{u_i(t) = 0\}$ for some i .

Introduce the notation

$$\Gamma_\alpha^{u_i}(t, \lambda) = \iota_{\lambda - u_i} \Gamma_\alpha(t, \lambda), \quad \alpha \in Q.$$

The vertex operator product (7.1) is well defined in the $(\lambda - u_i)$ -adic topology, and we have

$$\Gamma_\alpha^{u_i}(t, \mu) \Gamma_\beta^{u_i}(t, \lambda) = B_{\alpha,\beta}^{u_i}(t, \mu, \lambda) : \Gamma_\alpha^{u_i}(t, \mu) \Gamma_\beta^{u_i}(t, \lambda) :,$$

where the phase factor can be identified (for the same reason we used to derive (7.5)) with the Laurent series expansion

$$\iota_{\lambda - u_i} \iota_{\mu - u_i, \lambda - u_i} \tilde{B}_{\alpha,\beta}(t, \lambda; \mu - \lambda).$$

Here

$$(7.10) \quad \tilde{B}_{\alpha,\beta}(t, \lambda; \xi) = \lim_{\varepsilon \rightarrow 0} \exp \left(\int_{t_0 - \varepsilon \mathbf{1}}^{t - \lambda \mathbf{1}} I_\alpha^{(0)}(t', \xi) \bullet_{t'} I_\beta^{(0)}(t', 0) \right),$$

where the integration is along a ξ -path C such that β vanishes as $t' \rightarrow t_0$, and the limit is along a straight segment such that the line segment $[\lambda + \varepsilon, \mu + \varepsilon]$ does not intersect 0 as ε moves toward 0. Such a path exists provided $\xi := \mu - \lambda$ is sufficiently small.

Theorem 7.4. *For every $\alpha \in Q$ and every cycle β vanishing over t_0 , we have*

$$B_{\alpha,\beta}(t, \lambda; \xi) = c_{\alpha,\beta} \tilde{B}_{\alpha,\beta}(t, \lambda; \xi),$$

where $c_{\alpha,\beta}$ is a constant independent of t, λ and μ .

Note that Theorem 7.4 implies Theorem 6.8 (b), because after taking log of both sides of the above identity and differentiating $\partial_\lambda \partial_\mu$, the left-hand side becomes the analytic continuation of the propagator $P_{\alpha,\beta}(t, \lambda; \mu - \lambda)$ while the Laurent series expansion of the right-hand side is (6.13). The proof of Theorem 6.8 (a) was already obtained in the previous subsection. Indeed, if α' and α'' are cycles invariant with respect to the local monodromy, then the periods $I_{\alpha'}^{(0)}(t', \xi)$ and $I_{\alpha''}^{(0)}(t', 0)$

are analytic for all t' in a neighborhood of t_0 , which implies that the integral (7.4) is analytic in (t, λ) .

Let us denote the ratio $B_{\alpha,\beta}(t, \lambda; \xi)/\tilde{B}_{\alpha,\beta}(t, \lambda; \xi)$ by

$$(7.11) \quad f_{\alpha,\beta}(t_0, \xi) := \lim_{(\varepsilon', \varepsilon'') \rightarrow 0} \exp \left(\int_{-\varepsilon' \mathbf{1}}^{t_0 - \varepsilon'' \mathbf{1}} I_{\alpha}^{(0)}(t', \xi) \bullet_{t'} I_{\beta}^{(0)}(t', 0) \right).$$

We will prove that $f_{\alpha,\beta}(t_0, \xi)$ is analytic in a neighborhood of $\xi = 0$ and is locally constant with respect to t_0 . Finally, we will check that the function is homogeneous of degree 0, so it must be a constant independent of ξ .

7.3. Analyticity at $\xi = 0$. Let us fix the following notation. The space of miniversal deformations will be presented as $B = B_{N-1} \times \mathbb{C}$, where \mathbb{C} is the coordinate line through $\mathbf{1}$, the so called *primitive direction*, and B_{N-1} is the $(N-1)$ -dimensional space spanned by the remaining coordinate axes. Given $t \in B$, we put $'t \in B_{N-1}$ for the projection of t on the first factor. Let us point out that $u_i(t) = u_i('t) + t_N$, therefore the points on the discriminant are precisely the points of the form $t_0 = 't_0 - u_i('t_0)\mathbf{1}$ for some critical value u_i .

Assume now that $'t_0 \in B_{N-1}$ is generic, so that the corresponding critical values are pairwise distinct. Note that the radius of convergence of the Laurent series expansion near $\lambda = u_i('t_0)$ of the period $I_{\alpha}^{(0)}('t_0, \lambda)$, viewed as a function of λ only, is

$$\rho_i := \rho_i('t_0) := \min_j |u_j('t_0) - u_i('t_0)|.$$

Let us put $x_i := \rho_i/2 - u_i('t_0)$ and fix $'t_0 + x_i\mathbf{1}$ as a local reference point in the corresponding disk of convergence $D(u_i('t_0), \rho_i)$. Here we have used the following notation:

$$D(u, r) = \{ 't_0 + (x - u)\mathbf{1} \mid |x| < r \}.$$

Given a positive number $\rho = \rho('t_0)$ we construct the following sets of disks (see Fig. 2):

$$(7.12) \quad D(u_i('t_0), \rho), \quad 1 \leq i \leq N$$

and

$$(7.13) \quad D(x_i, \rho), \quad 1 \leq i \leq N.$$

We pick $\rho > 0$ such that the disks (7.12) and (7.13) are pairwise disjoint and such that $D(x_i, \rho)$ is contained in the domain of convergence $D(u_i('t_0), \rho_i)$. For example, if we set

$$\rho('t_0) = \min_{1 \leq i \leq N} \rho_i/4,$$

then all these requirements are satisfied.

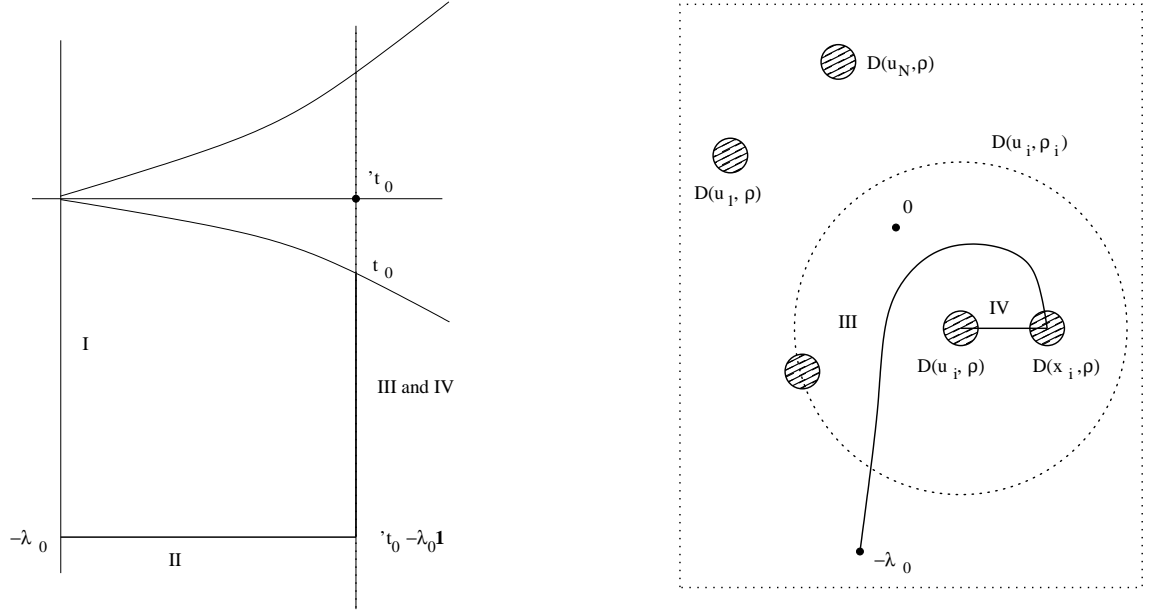

FIGURE 2. Integration path

Lemma 7.5. *Let $t_0 = 't_0 - u_i('t_0)\mathbf{1}$ be a generic point on the discriminant. Then $f_{\alpha,\beta}(t_0, \xi)$ extends analytically inside the disk $|\xi| < \rho$.*

Proof. Let us split the integration path in (7.11) into four pieces (see Fig. 2):

$$(7.14) \quad \int_{-\varepsilon'\mathbf{1}}^{-\lambda_0\mathbf{1}} + \int_{-\lambda_0\mathbf{1}}^{t_0-\lambda_0\mathbf{1}} + \int_{t_0-\lambda_0\mathbf{1}}^{t_0+(\rho_i/2)\mathbf{1}} + \int_{t_0+(\rho_i/2)\mathbf{1}}^{t_0-\varepsilon''\mathbf{1}},$$

where λ_0 can be chosen as large as we wish. The first two integrals were already analyzed at the end of Sect. 7.1. Namely, their contribution after passing to the limit $\varepsilon' \rightarrow 0$ is

$$(7.15) \quad \log B_{\alpha,\beta}(t_0, \lambda_0; \xi) = (\alpha|\beta) \log \xi + \dots,$$

where the dots stand for some function that depends analytically on ξ .

Note that in the third integral the path can be deformed homotopically so that it does not intersect the disks (7.12). In this case, the distance between a point t' on the integration path and a point $'t_0 - u_j('t_0)\mathbf{1}$ ($1 \leq j \leq N$) is more than ρ . The singularities of the period $I^{(0)}(t', \xi)$ are precisely at the points

$$t' - \xi\mathbf{1} = 't_0 - u_j('t_0)\mathbf{1}, \quad 1 \leq j \leq N,$$

which means that as long as $|\xi| < \rho$ the period will be analytic in ξ . In other words, the third integral is analytic for $|\xi| < \rho$.

It remains only to analyze the last integral. Let us make the substitution

$$t' = t_0 + x\mathbf{1} \quad \Rightarrow \quad u_i(t') = x;$$

then the integral becomes

$$\int_{\rho_i/2}^{-\varepsilon''} (I_\alpha^{(0)}(t_0, \xi - x), I_\beta^{(0)}(t_0, -x)) dx.$$

Since the integration path and the corresponding ξ -strip (for $|\xi| < \rho$) are entirely in the disk of convergence, we can compute the above integral via its Laurent series expansion

$$I_\beta^{(0)}(t_0, \xi - x) = \frac{\pm 2}{\sqrt{2(\xi - x)}} \left(e_i + \sum_{m=1}^{\infty} a_m(t_0) (2(\xi - x))^m \right),$$

where (see Proposition 4.6)

$$(7.16) \quad a_m(t_0) = \frac{\pm 2 \Psi_{t_0} R_m(t_0) e_i}{(2m-1)!!}, \quad m \geq 0.$$

Let us decompose $\alpha = \alpha' + (\alpha|\beta)\beta/2$, where α' is invariant with respect to the local monodromy. Then $I_{\alpha'}^{(0)}(t', \xi)$ is analytic in ξ , which implies that its contribution to the integral is analytic, i.e., we may replace α by $(\alpha|\beta)\beta/2$.

Multiplying out the Laurent series and integrating term by term we get

$$(\alpha|\beta) \int_{\rho_i/2}^{-\varepsilon''} \frac{dx}{\sqrt{(\xi - x)(-x)}} + O(\xi) \log(\sqrt{\xi + \varepsilon''} + \sqrt{\varepsilon''}),$$

up to terms that depend analytically on ξ or have order $O(\sqrt{\varepsilon''})$. The second term must vanish, because if we let ε'' go twice around 0, then according to Lemma 7.2 our integral should change by a constant, while the second term changes by a function proportional to ξ . Of course, we can check the vanishing directly (by using (7.16)), but then we would have to repeat the proof of Lemma 7.2. The first integral is straightforward to compute, namely it is

$$-2(\alpha|\beta) \log(\sqrt{\xi - x} + \sqrt{-x}) \Big|_{\rho_i/2}^{\varepsilon''} = -2(\alpha|\beta) \log(\sqrt{\xi + \varepsilon''} + \sqrt{\varepsilon''}) + \dots,$$

where the dots indicate a function analytic in the disk $|\xi| < \rho$. Passing to the limit we see that our integral up to analytic terms is $-(\alpha|\beta) \log \xi$. This singularity cancels, up to an integer multiple of $2\pi\sqrt{-1}$, with the

singularity (7.15) of the first two integrals (7.14). Finally, note that if ε' or ε'' makes a small loop around 0, then the integral gains an integer multiple of $\pm 2\pi\sqrt{-1}$. This proves that the limit $(\varepsilon', \varepsilon'') \rightarrow 0$ exists and it depends analytically on ξ as claimed. \square

Lemma 7.6. *The function $f_{\alpha,\beta}(t_0, \xi)$ is locally constant with respect to t_0 .*

Proof. Let us take a small neighborhood U of t_0 in B ; then $u_j = u_j(t)$, $1 \leq j \leq N$ are local coordinates in U and the local equation of the discriminant in these coordinates is given by $u_i = 0$. In other words, the critical values $(u_1, \dots, \hat{u}_i, \dots, u_N)$ are local coordinates on the discriminant near t_0 . In the integral representation (7.14) only the last two integrals depend on t_0 , so let us look at them more carefully. We have an improper integral on the complex plane with $N - 1$ punctures:

$$\mathbb{C} \setminus \{u_1(t_0), \dots, \widehat{u_i(t_0)}, \dots, u_N(t_0)\}, \quad \mathbb{C} \equiv \{t_0\} \times \mathbb{C}.$$

For homotopy reasons, we may think that varying t_0 along the discriminant is equivalent to still integrating along the same path but changing the positions of the punctures $u_j(t_0)$, $j \neq i$. However, thanks to Lemma 7.3 the integral does not depend on the position of the punctures. \square

7.4. Proof of Theorem 7.4. In order to prove that $f_{\alpha,\beta}$ is a constant, let us see how the integral changes under rescaling $\xi \mapsto c\xi$, where c is a positive constant sufficiently close to 1. Recall that the flat coordinates were assigned degrees $1 - d_i = \deg(\tau_i)$, where d_i is the weighted-homogeneous degree of the corresponding polynomial $\partial_i f$ (see Sect. 4). It follows that the structure constants $C_{ij}^k(\tau)$ of the Frobenius multiplication, defined by

$$\partial_i \bullet_{\tau} \partial_j = \sum_{k=1}^N C_{ij}^k(\tau) \partial_k$$

are homogeneous of degree $d_i + d_j - d_k$.

Let us look at the integrand of $f_{\alpha,\beta}(\xi)$,

$$I_{\beta}^{(0)}(t, \xi) \bullet_t I_{\beta}^{(0)}(t, 0) = \sum_{i,j,k=1}^N (I_{\beta}^{(0)}(t, \xi), \partial_k) C_{ij}^k(\tau) (I_{\beta}^{(0)}(t, 0), d\tau_j) d\tau_i.$$

Since the periods satisfy the homogeneity equation (cf. (4.4), (4.5)):

$$(\lambda \partial_{\lambda} + E) I_{\beta}^{(0)}(t, \lambda) = (\theta - 1/2) I_{\beta}^{(0)}(t, \lambda)$$

and

$$\theta(\partial_k) = (d/2 - d_k) \partial_k, \quad \theta(d\tau_j) = (d_j - d/2) d\tau_j, \quad {}^T \theta = -\theta,$$

we see that $(I_\beta^{(0)}(t, \xi), \partial_k)$ and $(I_\beta^{(0)}(t, 0), d\tau_j)$ are homogeneous of degrees $d_k - (d+1)/2$ and $-d_j + (d-1)/2$, respectively. It follows that the degree of the integrand is

$$d_k - (d+1)/2 + d_i + d_j - d_k - d_j + (d-1)/2 + (1-d_i) = 0.$$

This means that our function $f_{\alpha,\beta}(\xi)$ is homogeneous of degree 0, i.e., $f_{\alpha,\beta}(c\xi) = f_{\alpha,\beta}(\xi)$ for all c sufficiently close to 1. Therefore, only the constant term in the Taylor series expansion of $f_{\alpha,\beta}(\xi)$ at $\xi = 0$ could be non-zero. This completes the proof of Theorem 7.4.

8. \mathcal{W} -CONSTRAINTS

In this section we prove our main result, Theorem 1.1. The proof consists of several simple steps.

8.1. Reduction to analyticity at the critical values. Recall that for each $t \in B$, the operator series $Y_t^\infty(a, \lambda)$ defined in Sect. 6.2 provide a σ -twisted representation of the vertex algebra \mathcal{F} on the twisted Fock space \mathcal{F}_h . Let us complete \mathcal{F}_h with respect to the formal topology near $\mathbf{q} = -\mathbf{1}z$, i.e., define

$$\overline{\mathcal{F}}_h = \mathbb{C}_h[[q_0, q_1 + \mathbf{1}, q_2, \dots]].$$

Then the action of $Y_t^\infty(a, \lambda)$ on elements of $\overline{\mathcal{F}}_h$ still makes sense, since the operator series are given by the Wick formula (6.7) and the periods $I_\alpha^{(n)}(t, \lambda) \rightarrow 0$ in the formal λ^{-1} -adic topology as $n \rightarrow \infty$.

By definition, the total descendant potential is an element of yet another completion of the twisted Fock space, namely

$$\mathcal{D}_{X_N} \in \mathbb{C}_h[[q_0 - \tau, q_1 + \mathbf{1}, q_2, \dots]] = \widehat{\mathcal{S}}_t^{-1} \overline{\mathcal{F}}_h$$

(see (5.4), (5.5) and Lemma 5.6). The latter is equipped with the structure of a σ -twisted \mathcal{F} -module via the operator series

$$Y(a, \lambda) := Y_0^\infty(a, \lambda), \quad a \in \mathcal{F}.$$

If $a \in \mathcal{W}_{X_N}$, then due to the σ -invariance, $Y(a, \lambda)$ has only integral powers of λ . Theorem 1.1 is equivalent to the statement that $Y(a, \lambda)\mathcal{D}_{X_N}$ has no negative powers of λ for all $a \in \mathcal{W}_{X_N}$.

Let us assume that $a \in \mathcal{W}_{X_N}$, $t \in B$ is generic and $|\lambda|$ is sufficiently large, so that the Laurent series expansions are convergent. By Lemma 6.11, we have

$$Y(a, \lambda) \widehat{\mathcal{S}}_t^{-1} = \widehat{\mathcal{S}}_t^{-1} Y_t^\infty(a, \lambda),$$

which together with (5.4) gives

$$Y(a, \lambda)\mathcal{D}_{X_N} = e^{F^{(1)}(t)} \widehat{\mathcal{S}}_t^{-1} Y_t^\infty(a, \lambda) \mathcal{A}_t,$$

where \mathcal{A}_t is the ancestor potential (5.5). Thus, $Y(a, \lambda)\mathcal{D}_{X_N}$ has no negative powers of λ if and only if $Y_t^\infty(a, \lambda)\mathcal{A}_t$ has the same property.

Since \mathcal{A}_t is tame, the coefficients of $X_t(a, \lambda)\mathcal{A}_t$ are polynomial expressions in the coefficients of $X_t(a, \lambda)$, i.e., $Y_t^\infty(a, \lambda)\mathcal{A}_t$ is the Laurent series expansion of $X_t(a, \lambda)\mathcal{A}_t$ at $\lambda = \infty$. We want to show that all coefficients of the series $X_t(a, \lambda)\mathcal{A}_t$ are polynomials in λ . Since $X_t(a, \lambda)\mathcal{A}_t$ is monodromy invariant and has singularities only at the critical values, this is equivalent to the condition that $X_t(a, \lambda)\mathcal{A}_t$ does not have poles at the critical values $\lambda = u_i(t)$ for $1 \leq i \leq N$.

8.2. Reduction to the case of Virasoro constraints of an A_1 -singularity. For $a \in \mathcal{W}_{X_N}$, we analytically continue $X_t(a, \lambda)$ to a neighborhood of $\lambda = u_i(t)$. The vanishing cycle over the point $(t, u_i(t)) \in \Sigma$ will be denoted by β .

Recall that $\mathcal{F}_\beta \subset \mathcal{F}$ is the subalgebra generated by β , and \mathcal{F}_β^\perp is the subalgebra generated by all $\alpha \in \mathfrak{h}$ such that $(\alpha|\beta) = 0$ (see (6.14), (6.15)). Then, according to (6.16), for every $a \in \mathcal{F}$ we can write

$$a = \sum_k a_{(-1)}^k b^k, \quad a^k \in \mathcal{F}_\beta^\perp, \quad b^k \in \mathcal{F}_\beta.$$

Lemma 8.1. *Assume that $a \in \mathcal{F}$ is written as above with linearly independent a^k . Then $e^{\beta}_{(0)}a = 0$ if and only if all b^k lie in the Virasoro vertex algebra generated by $\omega_\beta := \beta_{(-1)}\beta/4$.*

Proof. Since $e^{\beta}_{(0)}$ is a derivation of the (-1) -st product and $e^{\beta}_{(0)}a^k = 0$, we see that $e^{\beta}_{(0)}a = 0$ if and only if $e^{\beta}_{(0)}b^k = 0$ for all k . This means that b^k lie in the \mathcal{W}_{A_1} -algebra corresponding to the lattice $\mathbb{Z}\beta$, which is just the Virasoro vertex algebra (cf. Remark 2.1). \square

By Theorem 6.9 (a) and (c), the operators $X_t(a^k, \lambda)$ are regular at $\lambda = u_i$ and

$$Y_t^{u_i}(a, \lambda)\mathcal{A}_t = \sum_k Y_t^{u_i}(a^k, \lambda) Y_t^{u_i}(b^k, \lambda)\mathcal{A}_t,$$

where $Y_t^{u_i}(a, \lambda)$ denotes the Laurent series expansion at $\lambda = u_i$ of $X_t(a, \lambda)$. If we prove that $Y_t^{u_i}(b^k, \lambda)\mathcal{A}_t$ does not have a pole at $\lambda = u_i$, then the above expression does not have a pole as well.

Due to Lemma 6.12,

$$Y_t^{u_i}(b, \lambda) \widehat{\Psi}_t \widehat{R}_t = \widehat{\Psi}_t \widehat{R}_t Y_{u_i}^{A_1}(b, \lambda), \quad b \in \mathcal{F}_\beta,$$

where the operator series $Y_{u_i}^{A_1}(b, \lambda)$ provide an r_β -twisted representation of the vertex algebra \mathcal{F}_β on $\mathcal{F}_\mathfrak{h}^{\text{tame}}$ (see the discussion before Lemma

6.12). Then (5.5) implies that for $b \in \mathcal{F}_\beta$,

$$Y_t^{u_i}(b, \lambda) \mathcal{A}_t(\mathbf{q}) = \widehat{\mathcal{R}}_t Y_{u_i}^{A_1}(b, \lambda) \prod_{j=1}^N \mathcal{D}_{\text{pt}}(\hbar \Delta_j; j \mathbf{q}),$$

where $Y_{u_i}^{A_1}(b, \lambda)$ is acting on the i -th factor in the product.

When b is in the Virasoro vertex algebra generated by ω_β , the operators $Y_{u_i}^{A_1}(b, \lambda)$ give an untwisted representation. By Corollary 3.5, the regularity of $Y_{u_i}^{A_1}(b, \lambda)$ at $\lambda = u_i$ follows from the regularity of the generating field $Y_{u_i}^{A_1}(\omega_\beta, \lambda)$. Therefore, we only need to verify that the Virasoro constraints for an A_1 -singularity coincide with the usual Virasoro constraints for the Witten–Kontsevich tau-function \mathcal{D}_{pt} .

8.3. Virasoro constraints for an A_1 -singularity. Let us assume now that $F(t, x) = x^2/2 + t$ is the miniversal deformation of an A_1 -singularity. Then the period has the form

$$I_\beta^{(0)}(t, \lambda) = \frac{2}{\sqrt{2(\lambda - t)}},$$

where the vanishing cycle over the point $(t, \lambda) \in B \times \mathbb{C}$ is the 0-dimensional cycle

$$\beta = [x_+(t, \lambda)] - [x_-(t, \lambda)], \quad x_\pm(t, \lambda) = \pm \sqrt{2(\lambda - t)}.$$

From here we find for $k \geq 0$

$$\begin{aligned} (-1)^{k+1} I_\beta^{(k+1)}(t, \lambda) &= (-\partial_\lambda)^{k+1} I_\beta^{(0)}(t, \lambda) = 2^{-k-\frac{1}{2}} (2k+1)!! (\lambda - t)^{-k-\frac{3}{2}}, \\ I_\beta^{(-k)}(t, \lambda) &= (\partial_\lambda)^{-k} I_\beta^{(0)}(t, \lambda) = \frac{2^{k+\frac{1}{2}}}{(2k-1)!!} (\lambda - t)^{k-\frac{1}{2}}, \end{aligned}$$

where $(-1)!! := 1$. After quantization (see (6.4), (6.5)), we obtain the differential operator

$$X_t(\beta, \lambda) = \partial_\lambda \widehat{\mathbf{f}}_\beta(t, \lambda) = \sum_{n:\text{odd}} J_n (\lambda - t)^{-\frac{n}{2}-1},$$

where for $k = 0, 1, 2, \dots$

$$J_{2k+1} = 2^{-k-\frac{1}{2}} (2k+1)!! \hbar^{1/2} \frac{\partial}{\partial q_k}, \quad J_{-2k-1} = \frac{2^{k+\frac{1}{2}}}{(2k-1)!!} \hbar^{-1/2} q_k.$$

The formula for the propagator (6.6), (6.13) assumes the form

$$\begin{aligned} P_{\beta, \beta}(t, \lambda; \mu - \lambda) &= \sum_{k=0}^{\infty} (2k+1) (\mu - t)^{-k-\frac{3}{2}} (\lambda - t)^{k-\frac{1}{2}} \\ &= -2\mu_{\mu-t, \lambda-t} \partial_\mu \left((\mu - \lambda)^{-1} (\mu - t)^{1/2} (\lambda - t)^{-1/2} \right). \end{aligned}$$

On the other hand, we have

$$X_t(\omega_\beta, \lambda) = \frac{1}{4}X_t(\beta_{(-1)}\beta, \lambda) = \frac{1}{4}:X_t(\beta, \lambda)X_t(\beta, \lambda): + \frac{1}{4}P_{\beta, \beta}^0(t, \lambda).$$

After a short computation, we find $P_{\beta, \beta}^0(t, \lambda) = (\lambda - t)^{-2}/4$, which implies

$$X_t(\omega_\beta, \lambda) = \sum_{m \in \mathbb{Z}} L_m (\lambda - t)^{-m-2},$$

where the Virasoro operators are

$$L_m = \frac{1}{16}\delta_{m,0} + \frac{1}{4} \sum_{k \in \mathbb{Z}} :J_{2(k+m)+1}J_{-2k-1}:$$

For example, the first few operators are as follows:

$$\begin{aligned} L_{-1} &= \frac{1}{2\hbar}q_0^2 + \sum_{k=0}^{\infty} q_{k+1} \frac{\partial}{\partial q_k}, \\ L_0 &= \frac{1}{16} + \frac{1}{2} \sum_{k=0}^{\infty} (2k+1)q_k \frac{\partial}{\partial q_k}, \\ L_1 &= \frac{\hbar}{8} \frac{\partial^2}{\partial q_0^2} + \frac{1}{4} \sum_{k=0}^{\infty} (2k+3)(2k+1)q_k \frac{\partial}{\partial q_{k+1}}, \\ L_2 &= \frac{3\hbar}{8} \frac{\partial^2}{\partial q_0 \partial q_1} + \frac{1}{8} \sum_{k=0}^{\infty} (2k+5)(2k+3)(2k+1)q_k \frac{\partial}{\partial q_{k+2}}. \end{aligned}$$

After setting $\hbar = 1$, these become precisely the Virasoro operators that characterize the Witten–Kontsevich tau-function (see [104]).

Finally, let us point out that the total descendant potential is obtained from a product of formal power series that are obtained from the Witten–Kontsevich tau-function by rescaling:

$$\mathcal{D}_{\text{pt}}(\hbar, \mathbf{q}) \mapsto \mathcal{D}_{\text{pt}}(\hbar\Delta_i, \mathbf{q}\sqrt{\Delta_i}).$$

Since the above Virasoro operators are invariant under such a rescaling, the rescaled potentials still satisfy the same Virasoro constraints.

This completes the proof of Theorem 1.1.

ACKNOWLEDGEMENTS

The authors benefited from attending the AIM workshop “Integrable systems in Gromov–Witten and symplectic field theory” (January 30 – February 3, 2012) and, in particular, from discussions with B. Dubrovin and S. Shadrin. The second author benefited from conversations with E. Frenkel, A. Givental, and K. Saito. The first author is supported in

part by NSF and NSA grants and the second author is supported in part by a JSPS Grant-In-Aid.

REFERENCES

- [1] M. Adler and P. van Moerbeke, *A matrix integral solution to two-dimensional W_p -gravity*. *Comm. Math. Phys.* **147** (1992), 25–56.
- [2] V.I. Arnol'd, *Critical points of smooth functions, and their normal forms* (Russian). *Uspehi Mat. Nauk* **30** (1975), 3–65. *English translation*, *Russian Math. Surveys* **30** (1975), 1–75.
- [3] V.I. Arnol'd, S.M. Gusein-Zade, and A.N. Varchenko, *Singularities of differentiable maps. Vol. II. Monodromy and asymptotics of integrals*. *Monographs in Mathematics*, 83. Birkhäuser Boston, Inc., Boston, MA, 1988.
- [4] B. Bakalov and V.G. Kac, *Twisted modules over lattice vertex algebras*. In: “Lie theory and its applications in physics V,” 3–26, World Sci. Publishing, River Edge, NJ, 2004; <http://arxiv.org/abs/math.QA/0402315>.
- [5] B. Bakalov and V.G. Kac, *Generalized vertex algebras*. In: “Lie theory and its applications in physics VI,” 3–25, Heron Press, Sofia, 2006; <http://arxiv.org/abs/math.QA/0602072>.
- [6] B. Bakalov and T. Milanov, *\mathcal{W}_{N+1} -constraints for singularities of type A_N* . Preprint (2008); <http://arxiv.org/abs/0811.1965>.
- [7] B. Bakalov and N.M. Nikolov, *Jacobi identity for vertex algebras in higher dimensions*. *J. Math. Phys.* **47** (2006), no. 5, 053505, 30 pp.
- [8] K. Behrend, *Gromov–Witten invariants in algebraic geometry*. *Invent. Math.* **127** (1997), 601–617.
- [9] A. Beilinson and V. Drinfeld, *Chiral algebras*. *Amer. Math. Soc. Colloquium Pub.*, 51, Amer. Math. Soc., Providence, RI, 2004.
- [10] A.A. Belavin, A.M. Polyakov, and A.B. Zamolodchikov, *Infinite conformal symmetry in two-dimensional quantum field theory*. *Nuclear Phys. B* **241** (1984), 333–380.
- [11] R.E. Borcherds, *Vertex algebras, Kac–Moody algebras, and the Monster*. *Proc. Nat. Acad. Sci. USA* **83** (1986), 3068–3071.
- [12] N. Bourbaki, *Lie groups and Lie algebras*. Chapters 4–6. *Elements of Mathematics* (Berlin). Springer-Verlag, Berlin, 2002.
- [13] P. Bouwknegt, K. Schoutens, eds., *\mathcal{W} -symmetry*. *Adv. Ser. in Math. Phys.*, vol. 22, World Scientific, River Edge, NJ, 1995.
- [14] E. Brieskorn, *Singular elements of semi-simple algebraic groups*. In: *Proc. ICM, Vol. II (French)* (Nice, 1970), 279–284, Gauthier-Villars, Paris, 1971.
- [15] A. Buryak, H. Posthuma, and S. Shadrin, *A polynomial bracket for the Dubrovin–Zhang hierarchies*. Preprint (2010); <http://arxiv.org/abs/1009.5351>.
- [16] A. Buryak, H. Posthuma, and S. Shadrin, *On deformations of quasi-Miura transformations and the Dubrovin–Zhang bracket*. Preprint (2011); <http://arxiv.org/abs/1104.2722>.
- [17] A. De Sole and V.G. Kac, *Finite vs affine W -algebras*. *Japanese J. Math.* **1** (2006), 137–261.
- [18] P. Di Francesco, P. Mathieu, and D. Sénéchal, *Conformal field theory*. *Graduate Texts in Contemporary Physics*, Springer-Verlag, New York, 1997.

- [19] L.A. Dickey, *Soliton equations and Hamiltonian systems*. Second edition. Adv. Ser. in Math. Phys., vol. 26. World Scientific, River Edge, NJ, 2003.
- [20] R. Dijkgraaf and C. Vafa, *On geometry and matrix models*. Nuclear Phys. B **644** (2002), 21-39.
- [21] R. Dijkgraaf, C. Vafa, E. Verlinde and H. Verlinde, *The operator algebra of orbifold models*. Comm. Math. Phys. **123** (1989), 485–526.
- [22] R. Dijkgraaf, H. Verlinde, and E. Verlinde, *Loop equations and Virasoro constraints in nonperturbative two-dimensional quantum gravity*. Nuclear Phys. B **348** (1991), 435–456.
- [23] C. Dong, *Twisted modules for vertex algebras associated with even lattices*. J. Algebra **165** (1994), 91–112.
- [24] C. Dong and J. Lepowsky, *Generalized vertex algebras and relative vertex operators*. Progress in Math., vol. 112, Birkhäuser Boston, 1993.
- [25] C. Dong and J. Lepowsky, *The algebraic structure of relative twisted vertex operators*. J. Pure Appl. Algebra **110** (1996), 259-295.
- [26] C. Dong, H. Li and G. Mason, *Modular-invariance of trace functions in orbifold theory and generalized Moonshine*. Comm. Math. Phys. **214** (2000), 1–56.
- [27] B. Dubrovin, *Geometry of 2D topological field theories*. In: “Integrable systems and quantum groups” (Montecatini Terme, 1993), 120–348, Lecture Notes in Math., 1620, Springer, Berlin, 1996.
- [28] B. Dubrovin, S.-Q. Liu, and Y. Zhang, *Hamiltonian perturbations of hyperbolic systems of conservation laws. I. Quasi-triviality of bi-hamiltonian perturbations*. Comm. Pure Appl. Math. **59** (2006), 559–615.
- [29] B. Dubrovin and Y. Zhang, *Bi-Hamiltonian hierarchies in 2D topological field theory at one-loop approximation*. Comm. Math. Phys. **198** (1998), 311–361.
- [30] B. Dubrovin and Y. Zhang, *Frobenius manifolds and Virasoro constraints*. Selecta Math. (N.S.) **5** (1999), 423–466.
- [31] B. Dubrovin and Y. Zhang, *Normal forms of hierarchies of integrable PDEs, Frobenius manifolds and Gromov-Witten invariants*, a new 2005 version of arXiv:math/0108160v1, 295 pp.
- [32] W. Ebeling, *Functions of several complex variables and their singularities*. Graduate Studies in Math., 83. Amer. Math. Soc., Providence, RI, 2007.
- [33] T. Eguchi, K. Hori, and C.-S. Xiong, *Quantum cohomology and Virasoro algebra*. Phys. Lett. B **402** (1997), 71–80.
- [34] T. Eguchi, M. Jinzenji, and C.-S. Xiong, *Quantum cohomology and free-field representation*. Nucl. Phys. B **510** (1998), 608–622.
- [35] T. Eguchi and C.-S. Xiong, *Quantum cohomology at higher genus: Topological recursion relations and Virasoro conditions*. Adv. Theor. Math. Phys. **2** (1998), 219-229.
- [36] T. Eguchi and S.-K. Yang, *The topological $\mathbb{C}P^1$ -model and the large- N matrix integral*. Mod. Phys. Lett. A **9** (1994), 2893–2902.
- [37] C. Faber, S. Shadrin, and D. Zvonkine, *Tautological relations and the r -spin Witten conjecture*. Ann. Sci. Éc. Norm. Supér. (4) **43** (2010), no. 4, 621-658.
- [38] H. Fan, T. Jarvis, and Y. Ruan, *Geometry and analysis of spin equations*. Comm. Pure Appl. Math. **61** (2008), 745–788.

- [39] H. Fan, T. Jarvis, and Y. Ruan, *The Witten equation and its virtual fundamental cycle*. arXiv: math/0712.4025
- [40] V.A. Fateev and S.L. Lukyanov, *The models of two-dimensional conformal quantum field theory with Z_n symmetry*. Internat. J. Modern Phys. A **3** (1988), 507–520.
- [41] B. Feigin and E. Frenkel, *Quantization of the Drinfeld–Sokolov reduction*. Phys. Lett. B **246** (1990), 75–81.
- [42] B. Feigin and E. Frenkel, *Integrals of motion and quantum groups*. In: “Integrable systems and quantum groups” (Montecatini Terme, 1993), 349–418, Lecture Notes in Math., 1620, Springer, Berlin, 1996.
- [43] A.J. Feingold, I.B. Frenkel, and J.F.X. Ries, *Spinor construction of vertex operator algebras, triality, and $E_8^{(1)}$* . Contemporary Math., 121, Amer. Math. Soc., Providence, RI, 1991.
- [44] E. Frenkel and D. Ben-Zvi, *Vertex algebras and algebraic curves*. Math. Surveys and Monographs, vol. 88, Amer. Math. Soc., Providence, RI, 2001; 2nd ed., 2004.
- [45] E. Frenkel, A. Givental, and T. Milanov, *Soliton equations, vertex operators, and simple singularities*. Funct. Anal. Other Math., DOI 10.1007/s11853-010-0035-6
- [46] E. Frenkel, V. Kac, A. Radul, and W. Wang, $\mathcal{W}_{1+\infty}$ and $\mathcal{W}(\mathfrak{gl}_N)$ with central charge N . Comm. Math. Phys. **170** (1995), 337–357.
- [47] E. Frenkel, V. Kac, and M. Wakimoto, *Characters and fusion rules for W -algebras via quantized Drinfeld–Sokolov reduction*. Comm. Math. Phys. **147** (1992), 295–328.
- [48] E. Frenkel and M. Szczesny, *Twisted modules over vertex algebras on algebraic curves*. Adv. Math. **187** (2004), 195–227.
- [49] I.B. Frenkel, *Representations of Kac–Moody algebras and dual resonance models*. In: “Applications of group theory in physics and mathematical physics” (Chicago, 1982), 325–353, Lect. in Appl. Math., 21, Amer. Math. Soc., Providence, RI, 1985.
- [50] I.B. Frenkel and V.G. Kac, *Basic representations of affine Lie algebras and dual resonance models*. Invent. Math. **62** (1980), 23–66.
- [51] I. B. Frenkel, J. Lepowsky, and A. Meurman, *Vertex operator calculus*, in “Mathematical aspects of string theory,” Adv. Ser. Math. Phys., Vol. 1, World Sci. Publishing, Singapore, 1987, pp. 150–188.
- [52] I. B. Frenkel, J. Lepowsky, and A. Meurman, “Vertex operator algebras and the Monster,” Pure and Appl. Math., Vol. 134, Academic Press, Boston, 1988.
- [53] I.B. Frenkel and Y. Zhu, *Vertex operator algebras associated to representations of affine and Virasoro algebras*. Duke Math. J. **66** (1992), 123–168.
- [54] M. Fukuma, H. Kawai, R. Nakayama, *Continuum Schwinger–Dyson equations and universal structures in two-dimensional quantum gravity*. Internat. J. Modern Phys. A **6** (1991), 1385–1406.
- [55] E. Getzler, *A Darboux theorem for Hamiltonian operators in the formal calculus of variations*. Duke Math. J. **111** (2002), 535–560.
- [56] A. Givental, *Semisimple Frobenius structures at higher genus*. Internat. Math. Res. Notices **2001**, no. 23, 1265–1286.

- [57] A. Givental, *Gromov–Witten invariants and quantization of quadratic Hamiltonians*. Mosc. Math. J. **1** (2001), 551–568.
- [58] A. Givental, *A_{n-1} singularities and n KdV Hierarchies*. Mosc. Math. J. **3** (2003), 475–505.
- [59] A. Givental, *Symplectic geometry of Frobenius structures*. In: “Frobenius manifolds,” 91–112, Aspects Math., E36, Vieweg, Wiesbaden, 2004.
- [60] A. Givental and T. Milanov, *Simple singularities and integrable hierarchies*. In: “The breadth of symplectic and Poisson geometry,” 173–201, Progr. Math., 232, Birkhäuser Boston, Boston, MA, 2005.
- [61] P. Goddard, *Meromorphic conformal field theory*. In: “Infinite-dimensional Lie algebras and groups” (Luminy–Marseille, 1988), 556–587, Adv. Ser. Math. Phys., vol. 7, World Sci. Publishing, Teaneck, NJ, 1989.
- [62] J. Goeree, *W-constraints in 2D quantum gravity*. Nuclear Phys. B **358** (1991), 737–757.
- [63] C. Hertling, *Frobenius manifolds and moduli spaces for singularities*. Cambridge Tracts in Math., 151, Cambridge Univ. Press, Cambridge, 2002.
- [64] T. Jarvis, T. Kimura, and A. Vaintrob, *Moduli spaces of higher spin curves and integrable hierarchies*. Compositio Math. **126** (2001), 157–212.
- [65] V.G. Kac, *Infinite-dimensional Lie algebras*. 3rd ed., Cambridge Univ. Press, Cambridge, 1990.
- [66] V.G. Kac, *Vertex algebras for beginners*. University Lecture Series, vol. 10, Amer. Math. Soc., Providence, RI, 1996; 2nd ed., 1998.
- [67] V.G. Kac, D.A. Kazhdan, J. Lepowsky, and R.L. Wilson, *Realization of the basic representations of the Euclidean Lie algebras*. Adv. in Math. **42** (1981), 83–112.
- [68] V.G. Kac and D.H. Peterson, *112 constructions of the basic representation of the loop group of E_8* . In: “Symposium on anomalies, geometry, topology” (Chicago, Ill., 1985), 276–298, World Sci. Publ., Singapore, 1985.
- [69] V. Kac and A. Schwarz, *Geometric interpretation of the partition function of 2D gravity*. Phys. Lett. B **257** (1991), 329–334.
- [70] V.G. Kac and I.T. Todorov, *Affine orbifolds and rational conformal field theory extensions of $W_{1+\infty}$* . Comm. Math. Phys. **190** (1997), 57–111.
- [71] V.G. Kac and M. Wakimoto, *Exceptional hierarchies of soliton equations*. In: “Theta functions—Bowdoin 1987” (Brunswick, ME, 1987), 191–237, Proc. Sympos. Pure Math., 49, Part 1, Amer. Math. Soc., Providence, RI, 1989.
- [72] V.G. Kac, W. Wang, and C.H. Yan, *Quasifinite representations of classical Lie subalgebras of $W_{1+\infty}$* . Adv. in Math. **139** (1998), 56–140.
- [73] S. Kharchev, A. Marshakov, A. Mironov, A. Morozov, and S. Pakuliak, *Conformal matrix models as an alternative to conventional multi-matrix models*. Nuclear Phys. B **404** (1993), 717–750.
- [74] M. Kontsevich, *Intersection theory on the moduli space of curves and the matrix Airy function*. Comm. Math. Phys. **147** (1992), 1–23.
- [75] M. Kontsevich, *Enumeration of rational curves via toric actions*. In: “The moduli space of curves,” 335–368, Progr. in Math., 129, Birkhäuser Boston, Boston, MA, 1995.

- [76] M. Kontsevich and Yu. Manin, *Gromov–Witten classes, quantum cohomology, and enumerative geometry*. *Comm. Math. Phys.* **164** (1994), 525–562.
- [77] I.K. Kostov, *Gauge invariant matrix model for the \hat{A} - \hat{D} - \hat{E} closed strings*. *Phys. Lett. B* **297** (1992), 74–81.
- [78] J. Lepowsky, *Calculus of twisted vertex operators*, *Proc. Nat. Acad. Sci. USA* **82** (1985), 8295–8299.
- [79] J. Lepowsky, *Perspectives on vertex operators and the Monster*. In: “The mathematical heritage of Hermann Weyl,” *Proc. Sympos. Pure Math.*, Vol. 48, Amer. Math. Soc., Providence, RI, 1988, pp. 181–197.
- [80] J. Lepowsky and H. Li, *Introduction to vertex operator algebras and their representations*. *Progress in Math.*, 227, Birkhäuser Boston, Boston, MA, 2004.
- [81] J. Lepowsky and R.L. Wilson, *Construction of the affine Lie algebra $A_1^{(1)}$* . *Comm. Math. Phys.* **62** (1978), 43–53.
- [82] H. Li, *Local systems of twisted vertex operators, vertex operator superalgebras and twisted modules*. In: “Moonshine, the Monster, and related topics,” 203–236, *Contemp. Math.*, 193, Amer. Math. Soc., Providence, RI, 1996.
- [83] J. Li and G. Tian, *Virtual moduli cycles and Gromov–Witten invariants in general symplectic manifolds*. In: “Topics in symplectic 4-manifolds” (Irvine, CA, 1996), 47–83, *First Int. Press Lect. Ser. I*, Internat. Press, Cambridge, MA, 1998.
- [84] E. Looijenga, *A period mapping for certain semi-universal deformations*. *Compositio Math.* **30** (1975), 299–316.
- [85] F. Malikov, V. Schechtman, and A. Vaintrob, *Chiral de Rham complex*. *Comm. Math. Phys.* **204** (1999), 439–473.
- [86] Yu.I. Manin, *Frobenius manifolds, quantum cohomology, and moduli spaces*. *Amer. Math. Soc. Colloquium Pub.*, 47, Amer. Math. Soc., Providence, RI, 1999.
- [87] T. Milanov, *Gromov–Witten theory of $\mathbb{C}P^1$ and integrable hierarchies*. arXiv:math-ph/0605001.
- [88] T. Milanov, *The equivariant Gromov–Witten theory of $\mathbb{C}P^1$ and integrable hierarchies*. *Int. Math. Res. Not. IMRN* **2008**, Art. ID rnn 073, 21 pp.
- [89] T. Milanov and H.-H. Tseng, *The spaces of Laurent polynomials, Gromov–Witten theory of \mathbb{P}^1 -orbifolds, and integrable hierarchies*. *J. Reine Angew. Math.* **622** (2008), 189–235.
- [90] T. Milanov and H.-H. Tseng, *Equivariant orbifold structures on the projective line and integrable hierarchies*. *Adv. Math.* **226** (2011), 641–672.
- [91] A. Okounkov and R. Pandharipande, *The equivariant Gromov–Witten theory of \mathbb{P}^1* . *Ann. of Math. (2)* **163** (2006), 561–605.
- [92] P. Rossi, *Gromov–Witten theory of orbicurves, the space of tri-polynomials and symplectic field theory of Seifert fibrations*. *Math. Ann.* **348** (2010), 265–287.
- [93] Y. Ruan and G. Tian, *A mathematical theory of quantum cohomology*. *J. Differential Geom.* **42** (1995), 259–367.
- [94] K. Saito, *Extended affine root systems I. Coxeter transformations*. *Publ. RIMS, Kyoto Univ.* **21** (1985), 75–179.

- [95] K. Saito, *On periods of primitive integrals, I*. Preprint RIMS (1982).
- [96] M. Saito, *On the structure of Brieskorn lattice*. Ann. Inst. Fourier **39** (1989), 27–72.
- [97] K. Saito and A. Takahashi, *From primitive forms to Frobenius manifolds. From Hodge theory to integrability and TQFT tt^* -geometry*. Proc. Sympos. Pure Math. **78** (2008), 31–48.
- [98] G. Segal, *Unitary representations of some infinite-dimensional groups*. Comm. Math. Phys. **80** (1981), 301–342.
- [99] P. Slodowy, *Simple singularities and simple algebraic groups*. Lecture Notes in Math., 815, Springer, Berlin, 1980.
- [100] C. Teleman, *The structure of 2D semi-simple field theories*. arXiv:0712.0160 (2007).
- [101] J. van de Leur, *The n th reduced BKP hierarchy, the string equation and $BW_{1+\infty}$ -constraints*. Acta Appl. Math. **44** (1996), 185–206.
- [102] P. van Moerbeke, *Integrable foundations of string theory*. In: “Lectures on integrable systems” (Sophia-Antipolis, 1991), 163–267, World Sci. Publ., River Edge, NJ, 1994.
- [103] E. Witten, *Two-dimensional gravity and intersection theory on moduli space*. In: “Surveys in differential geometry,” 243–310, Lehigh Univ., Bethlehem, PA, 1991.
- [104] E. Witten, *On the Kontsevich model and other models of two-dimensional gravity*. In Proc. XXth Intern. Conf. on Differential Geometric Methods in Theoretical Physics, Vol. 1, 2 (New York, 1991), 176–216, World Sci. Publ., River Edge, NJ, 1992.
- [105] E. Witten, *Algebraic geometry associated with matrix models of two-dimensional gravity*. In: “Topological models in modern mathematics,” 235–269, Publish or Perish, Houston, TX, 1993.
- [106] A.B. Zamolodchikov, *Infinite extra symmetries in two-dimensional conformal quantum field theory* (Russian), Teoret. Mat. Fiz. **65** (1985), 347–359. *English translation*, Theoret. and Math. Phys. **65** (1985), 1205–1213.

DEPARTMENT OF MATHEMATICS, NORTH CAROLINA STATE UNIVERSITY, RALEIGH,
NC 27695, USA

E-mail address: bojko_bakalov@ncsu.edu

KAVLI IPMU, UNIVERSITY OF TOKYO (WPI), JAPAN

E-mail address: todor.milanov@ipmu.jp