

STABILITY OF HYBRID SYSTEMS

Michael S. Branicky, Electrical Engineering and Computer Science Department, Case Western Reserve University, USA

Keywords: Hybrid systems, Lyapunov stability, Multiple Lyapunov functions, Schur, State space.

Contents

1. Background and Motivation
 - 1.1. What is a Hybrid System?
 - 1.2. Why a Different Theory for Hybrid Systems?
 2. Early Results
 3. Stability via Multiple Lyapunov Functions
 4. Further Results
 - 4.1. Applications
- Bibliography

Glossary

- Asymptotic stability:** A definition of stability wherein small changes in initial condition are diminished as time progresses.
- Autonomous system:** A system whose dynamics are not explicitly dependent on time or external inputs.
- Continuous dynamics:** Equations governing the behavior of variables that continuously change value as a function of time.
- Continuous variable:** A variable whose values lie in a continuum, such as the real numbers.
- Controlled system:** A system whose dynamics is explicitly dependent on external inputs, which usually may be specified by a designer.
- Discrete dynamics:** Equations governing the behavior of variables that are immediately reset to new values over time.
- Discrete variable:** A variable whose values take on only a countable number of values.
- Dynamical system:** A set of equations describing how a set of variables change values over time.
- Equilibrium point:** A point that remains unchanged as a function of the dynamics of a system; if the system is placed there exactly, it will remain there forever.
- Global asymptotic stability:** A definition of stability wherein any perturbations in initial condition (no matter how large) are diminished as time progresses.
- Hybrid system:** A dynamical system possessing discrete and continuous variables and dynamics.
- Impulse:** A discontinuous change in a continuous variable's value.
- Jacobian matrix:** A matrix of partial derivatives relating changes in one vector of variables to changes in another, functionally dependent vector of variables.
- Lyapunov function:** An energy function associated with a dynamical system that decreases over time.
- Lyapunov stability:** A definition of stability based on the notion that small changes in initial condition lead to small changes in system behavior.
- Multiple Lyapunov functions:** A stability technique for hybrid systems in which a decreasing energy function is associated with each discrete state.

Sampled-data system: A dynamical system wherein continuous variables are updated at discrete, usually equally spaced, instants of time.

Schur: A matrix whose eigenvalues all have magnitude less than one.

State space: The space in which the variables of interest of a dynamical system take their values.

Switched system: A hybrid system formed by switching among different dynamical equations governing the system's behavior.

Summary

This section collects work on the general stability analysis of hybrid systems. The hybrid systems considered are those that combine continuous dynamics—represented by differential or difference equations—with finite dynamics—usually thought of as being a finite automaton. We present some general background on stability analysis, and then work on the stability analysis of hybrid control systems. Specifically, we review *multiple Lyapunov functions* as a tool for analyzing Lyapunov stability. Other stability notions and other analysis tools are discussed in the subsection *Going Further*. Specializing to hybrid systems with linear dynamics in each constituent mode and linear jump operators, we review some key theorems for impulsive systems and give corollaries encompassing several recently-derived “stability by first approximation” theorems in the literature.

1. Background and Motivation

Suppose we are given a dynamical system in R^n specified by a differential (respectively, difference) equation:

$$\Sigma: \quad \dot{x}(t) = f(x(t)) \quad (\text{respectively, } x(t+1) = f(x(t))). \quad (1)$$

An important concept when analyzing such systems is stability. We give a taste of stability theory below and refer the reader to the excellent introduction by Luenberger for further details and more advanced references.

Stability means that small changes in operating conditions, such as differences in initial data, lead to small changes in behavior. Specifically, let $x(t)$ and $z(t)$ be solutions of Σ when the initial conditions are x_0 and z_0 , respectively. Further, let $\|\cdot\|$ denote the Euclidean distance between vectors, $\|z - x\| = [\sum_{i=1}^n (z_i - x_i)^2]^{1/2}$.

Definition 1 (Lyapunov Stability of Solution) *A solution $x(t)$ of Σ is Lyapunov stable if for any $\varepsilon > 0$, there exists a $\delta(\varepsilon) > 0$ such that all solutions of Σ with $\|z(0) - x(0)\| < \delta$ are such that $\|z(t) - x(t)\| < \varepsilon$ for all $t > 0$.* △

An *equilibrium point* of Σ is one which remains unchanged under the dynamics, namely a point \bar{x} where $f(\bar{x}) = 0$ (respectively, $f(\bar{x}) = \bar{x}$). Since the equilibrium point \bar{x} is a particular kind of solution (namely, one where $x(t) \equiv \bar{x}$ for all t), we may talk of the Lyapunov stability of equilibrium points. Instead of simply repeating the definition for this specific case, though, it is convenient to introduce

some new notation. Let $B(\bar{x}, R)$ denote the ball of radius R about \bar{x} , that is, all the points y in the state space such that $\|\bar{x} - y\| < R$.

Definition 2 (Lyapunov Stability of Equilibrium Point) *An equilibrium point \bar{x} of Σ is Lyapunov stable if for any $R > 0$, there exists an r , $0 < r < R$, such that if z_0 is inside $B(\bar{x}, r)$, then $z(t)$ is inside $B(\bar{x}, R)$ for all $t > 0$.* \triangle

For an illustration of the concept, see Figure 1, which depicts two stable trajectories in continuous time. Other notions are defined in terms of this primitive concept. For instance, an equilibrium point is *asymptotically stable* if it is stable and there is a $A > 0$ such that if the system is initiated inside $B(\bar{x}, A)$ the trajectory is attracted to \bar{x} as time increases; it is *exponentially stable* if it is attracted to \bar{x} at an exponential rate, i.e., $\|x(t) - \bar{x}\| \leq ce^{-\mu t}$, $c, \mu > 0$; it is *globally asymptotically stable* if A may be taken arbitrarily large; it is *unstable* if it is not stable.

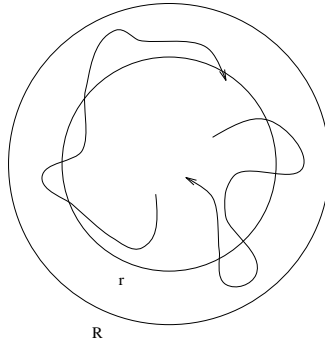

Figure 1: Lyapunov stability.

Besides introducing the notion of stability above, Lyapunov devised two methods for testing the stability of an equilibrium point, which have come to be known as (1) Lyapunov's indirect method, and (2) Lyapunov's direct method. The indirect method involves examining the stability of a linearized version of the function f . Specifically, one examines the *Jacobian matrix*, the $n \times n$ matrix of first derivatives of f with respect to x , evaluated at the equilibrium point:

$$F = \begin{bmatrix} \frac{\partial f_1}{\partial x_1} & \frac{\partial f_1}{\partial x_2} & \cdots & \frac{\partial f_1}{\partial x_n} \\ \frac{\partial f_2}{\partial x_1} & \frac{\partial f_2}{\partial x_2} & \cdots & \frac{\partial f_2}{\partial x_n} \\ \vdots & \vdots & \ddots & \vdots \\ \frac{\partial f_n}{\partial x_1} & \frac{\partial f_n}{\partial x_2} & \cdots & \frac{\partial f_n}{\partial x_n} \end{bmatrix}_{x=\bar{x}} \quad (2)$$

To first order near the equilibrium point,

$$f(\bar{x} + y) \approx f(\bar{x}) + Fy = Fy, \quad (\text{respectively, } \dot{y} = Fy) \quad (3)$$

so that

$$\dot{y}(t) = Fy(t) \quad (\text{respectively, } y(t+1) = Fy(t)) \quad (4)$$

gives a linear approximation of the perturbations to the solution of Σ near \bar{x} . In some cases, the stability properties of the system in Σ can be inferred from those of the linear system in Equation (4). In particular, if all the eigenvalues of F have strictly negative real parts (respectively, magnitude strictly less than one), then \bar{x} is an asymptotically stable equilibrium point of Σ . If any eigenvalue has a positive real part (respectively, magnitude greater than one), it is unstable. If all have non-positive real parts but some have zero real parts (respectively, have magnitude less than or equal to one but some have unity magnitude), then nothing can be concluded about stability from this indirect method alone.

Lyapunov's other, direct method for verifying stability works directly with the nonlinear system rather than its linearized version. The basic idea is to seek a type of "energy function" that "decreases along trajectories of the system." Next, we make these notions precise. Suppose that \bar{x} is an equilibrium point of a given dynamic system.

Definition 3 (Lyapunov Function) *A candidate Lyapunov function for the system Σ and the equilibrium point \bar{x} is a real-valued function V , which is defined over a region Ω of the state space that contains \bar{x} , and satisfies the two requirements:*

- *Continuity. V is continuous and, in the case of a continuous-time system, V has continuous derivative.*
- *Positive Definiteness. $V(x)$ has a unique minimum at \bar{x} with respect to all other points in Ω . Without loss of generality, we henceforth assume $V(\bar{x}) = 0$.*

A Lyapunov function for the system Σ and the equilibrium point \bar{x} is a candidate Lyapunov function V which also satisfies the requirement:

- *Non-increasing. Along any trajectory of the system contained in Ω the value of V never increases. That is, for a continuous-time system, the function $\dot{V}(x) = \nabla V(x)f(x) \leq 0$ for all x in Ω ;¹ for a discrete-time system, the function $\Delta V(x) = V(f(x)) - V(x) \leq 0$ for all x in Ω . \triangle*

With these definitions, we may state the following important theorem (see Luenberger's book, or our Theorem 16 in the case $N = 1$, for continuous- and discrete-time proofs).

Theorem 4 (Lyapunov Theorem) *If there exists a Lyapunov function $V(x)$ in the region $B(\bar{x}, R)$, $R > 0$, then the equilibrium point \bar{x} is Lyapunov stable.*

Summarizing, to use Lyapunov's direct method (in continuous time, for example) you

1. After examining your system, pick a Lyapunov function candidate V ;
2. Compute \dot{V} (respectively, ΔV);

¹ $\nabla V(x)$ is the gradient vector

$$\left[\frac{\partial V(x)}{\partial x_1}, \frac{\partial V(x)}{\partial x_2}, \dots, \frac{\partial V(x)}{\partial x_n} \right]. \tag{5}$$

3. Draw conclusions about the system Σ in Equation (1).

See Figure 2, which depicts these steps. Also, some important things to note are

- Engineering insight is used to pick V , e.g., in mechanical and electrical problems, V can often be chosen as the total (kinetic plus potential) energy of the system.
- The above Lyapunov theorem has a converse, but its sufficiency form stated above is often useful as a design tool (e.g., in adaptive control, where one chooses a candidate Lyapunov function and then a parameter update rule that will result in its being non-increasing over trajectories).

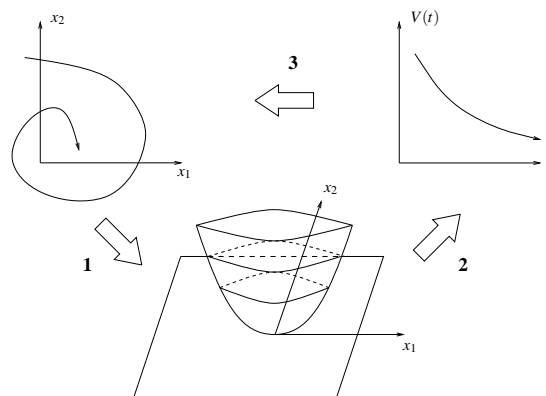

Figure 2: Systems analysis cycle for Lyapunov's direct method.

Given the above, whole books may be written—and many have—on the qualitative theory of dynamical systems, extending to theorems on asymptotic stability and instability, global and uniform versions, etc. For one example,

Theorem 5 (Luenberger) *Suppose V is a Lyapunov function for a dynamic system and an equilibrium point \bar{x} . Suppose in addition that*

- V is defined on the entire state space.
- $\dot{V}(x) < 0$ (respectively, $\Delta V(x) < 0$) for all $x \neq \bar{x}$.
- $V(x)$ goes to infinity as $\|x - \bar{x}\|$ goes to infinity.

Then \bar{x} is globally asymptotically stable.

1.1. What is a Hybrid System?

The simplest hybrid system is a *switched system*:

$$\dot{x}(t) = f_q(x(t)), \quad q \in \{1, \dots, N\}, \quad (6)$$

where $x(t) \in \mathbb{R}^n$. We add the following assumptions. (1) Each f_q is globally Lipschitz continuous. (2) The q 's are picked in such a way that there are finite switches in finite time.

Such systems are of “variable structure” or “multi-modal”; they are a simple model of (the continuous portion) of hybrid systems. We explain this below. The particular q at any given time may be chosen by some “higher process,” such as a controller, computer, or human operator, in which case we say that the system is *controlled*. It may also be a function of time or state or both, in which case we say that the system is *autonomous*. In the latter case, we may really just arrive at a single (albeit complicated) nonlinear, time-varying equation. However, one might gain some leverage in the analysis of such systems by considering them to be amalgams of simpler systems.

A real-world example of a switched system is one that arises in the control of the longitudinal dynamics of an aircraft. See Figure 3. It is desired that there is good tracking of pilot’s input, n_z , without violating angle-of-attack constraint. To accomplish this, engineers build a good tracking controller and a good safety control (which regulates about the maximum angle of attack) and combine them using simple logic. The resulting Max Controller is shown in Figure 4. It achieves the stated objectives.

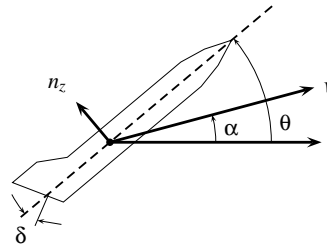

Figure 3: Longitudinal Aircraft View.

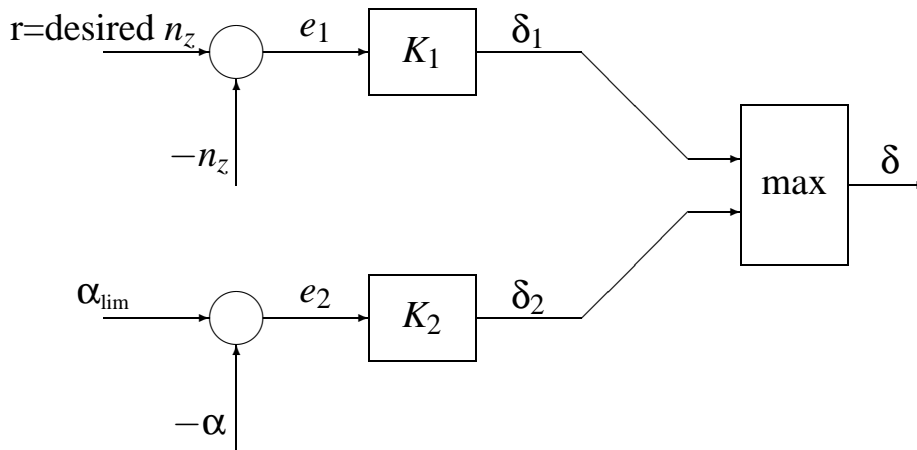

Figure 4: The Max Controller.

A particular case of of interest for Equation (6) is the case of *switched linear systems*, where each of the f_q is a linear system:

$$\dot{x}(t) = A_q(x(t)), \quad q \in \{1, \dots, N\}, \quad (7)$$

where $x(t) \in \mathbb{R}^n$.

In addition to the switching phenomenon discussed above, so-called *systems with impulse effect* often add the possibility of the state's jumping (also known as “resets”) when certain boundaries are crossed. In general, these boundaries are subsets of the space, M , but they may be given explicit representation in terms of the zeros of one or more functions.

$$\dot{z}(t) = f(z(t)), \quad (z,t) \notin M_t, \tag{8}$$

$$z(t^+) = J(z(t)), \quad (z,t) \in M_t \tag{9}$$

The interpretation of the above is that the dynamics evolves according to the differential equation while (z,t) is in the complement of $M_t \subset Z \times I$, but that the state is immediately reset according to the map J upon the (z,t) 's hitting the set M_t . See Bainov and Simeonov's book and Branicky's thesis for more details and conditions on when the dynamics is well-defined. There are three main cases of interest:

- Fixed Instants of Impulse Effect. The sets M_t are hyperplanes at fixed instants of $t = \tau_1, \tau_2, \dots$
- Mobile Instants of Impulse Effect. The sets M_t are a sequence of hypersurfaces $\sigma_k = \tau_k(x)$.
- Autonomous Impulse Effect. The sets M_t are constraints on the state space, i.e., they are of the form $M \times I, M \subset Z$.

As an example of a hybrid system consider Pait's two-state stabilizer for the simple harmonic oscillator (S.H.O.). See Figure 5. Here, the hybrid state consists of values for the continuous variables x and y , plus a location (discrete state) in the automaton. The dynamics of this flavor of hybrid system are such that it stays in a location for T seconds (as defined in that location) and then follows the transition arrow which is active (determined by conditions on the values of the continuous variables) to the next location. The system begins in State 2 (left) and stays there for $3\pi/4$ seconds. Example dynamics are shown in Figure 6.

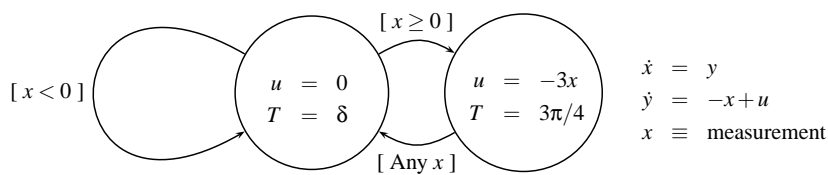

Figure 5: Pait's two-state hybrid S.H.O. stabilizer and S.H.O. equations.

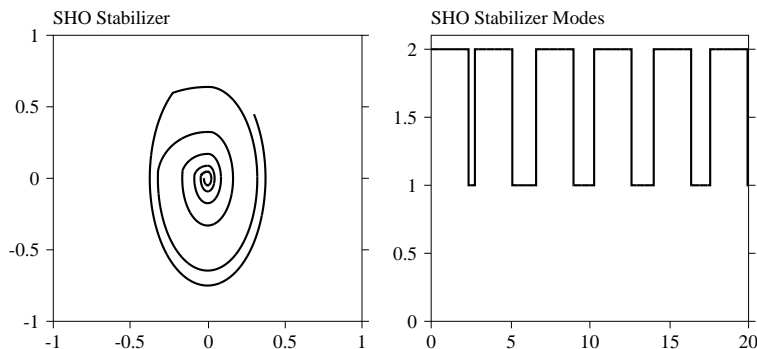

Figure 6: Phase Portrait and Mode Switchings for Pait's S.H.O. Stabilizer

A *hybrid dynamical system* is simply an indexed collection of dynamical systems plus rules for switching among them “jumping” among them (switching dynamical system and/or resetting the state). See Figure 7. This jumping occurs whenever the state satisfies certain conditions, given by its membership in a specified subset of the state space. Hence, the entire system can be thought of as a sequential patching together of dynamical systems with initial and final states, the jumps performing a reset to a (generally different) initial state of a (generally different) dynamical system whenever a final state is reached.

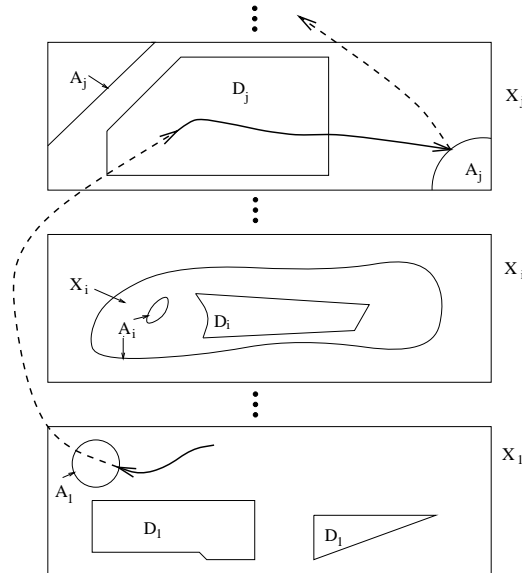

Figure 7: Example hybrid dynamical system.

1.2. Why a Different Theory for Hybrid Systems?

Imagine now that we want to analyze the (Lyapunov) stability of (an equilibrium point of) a hybrid system.

Why is a different theory needed for hybrid systems? The main reason is that stability of a hybrid system depends on (1) the dynamics of its constituent parts, and (2) the transition map, or “switching rules.”

Example 6 Consider $f_i(x) = A_i x$ where

$$A_1 = \begin{bmatrix} -1 & 10 \\ -100 & -1 \end{bmatrix}, \quad A_2 = \begin{bmatrix} -1 & 100 \\ -10 & -1 \end{bmatrix}. \quad (10)$$

Then one may check that each system $\dot{x} = f_i(x)$ is globally exponentially stable for $i = 1, 2$. See Figures 8 and 9, which plot one second of trajectories for f_1 and f_2 starting from $(1, 0)$, $(0, 1)$, respectively. Hence, the trivial switching rules “always use f_i ,” $i = 1, 2$, are stable. Another switching rule that is stable is one which uses f_2 in the second and fourth quadrants and f_1 in the first and third quadrants.

◇

However, it is easy to combine the above two globally asymptotically stable systems with a switching scheme that sends all trajectories to infinity:

Example 7 *The switched system using f_1 in the second and fourth quadrants and f_2 in the first and third quadrants is unstable. See Figure 10, which plots one second of the trajectory starting from $(10^{-6}, 10^{-6})$.* \diamond

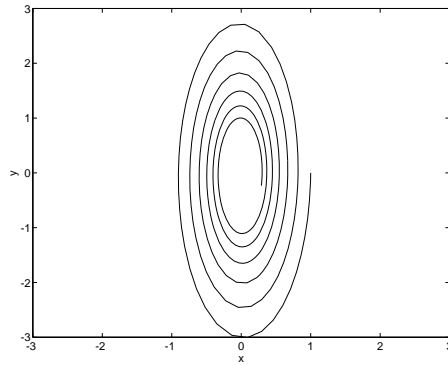

Figure 8: Trajectory of f_1 . Motion is clockwise.

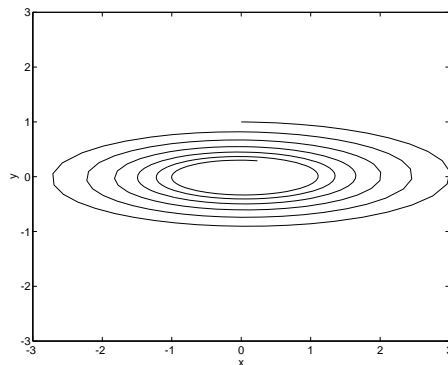

Figure 9: Trajectory of f_2 . Motion is clockwise.

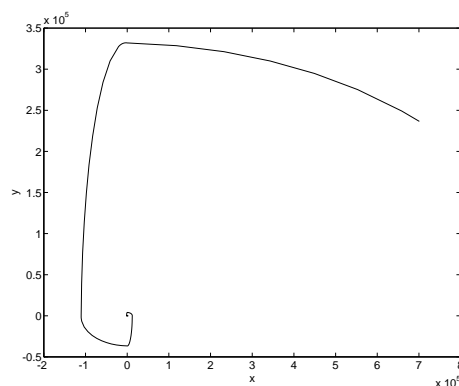

Figure 10: Trajectory of switched system. Motion is clockwise.

Such examples appear to be classical (cf. Åström). A similar example, producing a stable system by appropriately switching between two unstable ones is due to Utkin. The bottom line: even if we have Lyapunov functions for each system f_i individually, we need to impose restrictions on switching to guarantee stability.

There are other reasons why a different theory is needed. Sometimes, a single Lyapunov function might not exist. We will see this below. Another reason a new theory is needed is that finding

Lyapunov functions is a hard business even in the case of a single dynamical system. When one allows switching, the situation only worsens. However, if we can use our engineering insight about each sub-system to pick a Lyapunov function that decreases for it, and then check to see if some conditions for switching are satisfied, there is hope for proving the stability of hybrid systems. We will also see an example of this below.

2. Early Results

Models like Equation (7) have been studied for stability by many authors, including Ezzine and Haddad, Peleties and DeCarlo, Wicks *et al.*, and Feron. The former reference mainly considered switched systems where the sequence of matrices—and the times they are each applied—are periodic. They study stability, reachability, and observability of these periodic hybrid systems, and subsequently relax some results to the aperiodic case. As for aperiodic stability under some constraints, they give a sufficient condition based on estimates arising from the *matrix measure* (cf. Vidyasagar) of the constituent matrices. In particular,

Theorem 8 (Theorem 1, Ezzine and Haddad) *If matrix A_i is active for a fraction of time $p_i = \delta t_i/T$ in each time period of length T , then the hybrid system (7) is uniformly asymptotically stable if*

$$\sum_i \mu(A_i) p_i < 0, \quad (11)$$

where $\mu(A)$ is a matrix measure, that is, $\mu(A) = \lim_{\varepsilon \rightarrow 0^+} (\|I + \varepsilon A\| - 1)/\varepsilon$.

The theorem relies on the fact that over periods of time of length T , the system's fundamental matrix of solutions is a contraction. Another way to show stability is to use Lyapunov functions, to which we now turn.

In the papers by Peleties and DeCarlo, Wicks *et al.*, and Feron, the question of stabilization of systems as in Equation (7) is studied. We follow Feron in summarizing their results.

Definition 9 *The system (7) is quadratically stabilizable via state-feedback if and only if there exists a positive definite function $V(x) = x^T P x$, $\varepsilon > 0$, and a switching rule $q(x, t)$ such that*

$$\frac{d}{dt} V(x) < -\varepsilon x^T x \quad (12)$$

for all trajectories of the system (7).

Theorem 10 (Wicks *et al.*) *The system (7) is quadratically stabilizable if there exists a convex combination of the A_i that is asymptotically stable.*

Theorem 11 (Theorem 2.2, Feron) *Assume $N = 2$. The system (7) is quadratically stabilizable if and only if there exists a convex combination of A_1 and A_2 that is asymptotically stable.*

In Bainov and Simeonov's book and Pavlidis' work, more general hybrid systems are considered. The constituent systems considered need not be linear and impulsive jumps may occur. Most of the results for the former reference are in the case of fixed and mobile instants of impulse effects, but there is a section on stability of autonomous systems with impulse effect. Pavlidis considers systems in which there are "pulse firings" which impulsively reset the state. We merely wish to set the stage for multiple Lyapunov functions, discussed next. Hence, instead of giving full theoretical conditions (which are lengthy), we suffice to say that the *character* of these stability results is given by the following "theorem":

Theorem 12 *If there exists a Lyapunov function that is non-increasing along continuous actions and non-increasing over each impulse, then the system is stable.*

The same idea, in the case of linear systems was used in Peleties and DeCarlo. We touch on these in the next section.

Example 13 *As an example of this theory, consider the hybrid system with impulse effect that arises from the dynamics of a bouncing ball:*

$$\ddot{x} = -mg, \quad x > 0, \quad (13)$$

$$v^+ = -\rho v, \quad x = 0, \quad (14)$$

where x measures the ball's height above the ground, $v \equiv \dot{x}$ is its velocity, m its mass, g is the gravitational constant, and $0 \leq \rho \leq 1$ is the coefficient of restitution. Choose total energy as Lyapunov function:

$$V = \frac{1}{2}v^2 + mgx. \quad (15)$$

Then while the ball is in the air, $\dot{V} = 0$. At the bounce times, $V^+ = \frac{1}{2}(\rho^2 - 1)v^2 \leq 0$. Hence, the system is stable.

3. Stability via Multiple Lyapunov Functions

In this section, we discuss Lyapunov stability of switched systems via "multiple Lyapunov functions." The idea here is that even if we have Lyapunov functions for each system f_q individually, we need to impose restrictions on switching to guarantee stability. Indeed, it is easy to construct examples of two globally exponentially stable systems and a switching scheme that sends all trajectories to infinity as we saw earlier.

Below, we impose restrictions on switching sufficient to guarantee stability. We will make rigorous the following "theorem":

Theorem 14 (Multiple Lyapunov Method) *Given N dynamical systems, $\Sigma_1, \dots, \Sigma_N$, each with equilibrium point at the origin, and N candidate Lyapunov functions, V_1, \dots, V_N .*

notation. The switching sequence, along with Equation (6), completely describes the trajectory of the system according to the following rule: (q_k, t_k) means that the system evolves according to $\dot{x}(t) = f_{q_k}(x(t), t)$ for $t_k \leq t < t_{k+1}$. We denote this trajectory by $x_S(\cdot)$. Throughout, we assume that the switching sequence is *minimal* in the sense that $q_j \neq q_{j+1}$, $j \in \mathbb{Z}^+$.

We can take projections of this sequence onto its first and second coordinates, yielding the sequence of indices, $\pi_1(S) = x_0; q_0, q_1, \dots, q_N, \dots$, and the sequence of switching times, $\pi_2(S) = x_0; t_0, t_1, \dots, t_N, \dots$, respectively. Suppose S is a switching sequence as in Equation (18). We will denote by $S|q$ the sequence of switching times whose corresponding index is q . The *interval completion* $I(T)$ of a strictly increasing sequence of times $T = t_0, t_1, \dots, t_N, \dots$, is the set

$$\bigcup_{j \in \mathbb{Z}^+} (t_{2j}, t_{2j+1}). \quad (19)$$

Finally, let $\mathcal{E}(T)$ denote the *even sequence* of T : t_0, t_2, t_4, \dots .

Below, we say that V is a *candidate Lyapunov function* if V is a continuous, positive definite function (about the origin, 0) with continuous partial derivatives. Note this assumes $V(0) = 0$. We also use

Definition 15 (Lyapunov-like) *Given a strictly increasing sequence of times T in \mathbb{R} , we say that V is a Lyapunov-like function for function f and trajectory $x(\cdot)$ over T if*

- $\dot{V}(x(t)) \leq 0$ for all $t \in I(T)$,
- V is monotonically nonincreasing on $\mathcal{E}(T)$.

The second condition ensures that energy function V is not increasing at each time it is “switched in.”

Theorem 16 *Suppose we have candidate Lyapunov functions V_q , $q = 1, \dots, N$, and vector fields $\dot{x} = f_q(x)$ with $f_q(0) = 0$, for all q . Let S be the set of all switching sequences associated with the system.*

If for each $S \in \mathcal{S}$ we have that for all q , V_q is Lyapunov-like for f_q and $x_S(\cdot)$ over $S|q$, then the system is stable in the sense of Lyapunov.

Proof In each case, we do the proofs only for $N = 2$.

- *Continuous-time:* Let $R > 0$ be arbitrary. Let $m_i(\alpha)$ denote the minimum value of V_i on $S(\alpha)$. Pick $r_i < R$ such that in $B(r_i)$ we have $V_i < m_i(R)$. This choice is possible via the continuity of V_i . Let $r = \min(r_i)$. With this choice, if we start in $B(r)$, either vector field alone will stay within $B(R)$.

Now, pick $\rho_i < r$ such that in $B(\rho_i)$ we have $V_i < m_i(r)$. Set $\rho = \min(\rho_i)$. Thus, if we start in $B(\rho)$, either vector field alone will stay in $B(r)$. Therefore, whenever the other is first switched on we have $V_i(x(t_1)) < m_i(R)$, so that we will stay within $B(R)$. See Figures 12 and 11.

- *Discrete-time:* Let $R > 0$ be arbitrary. Let $m_i(\alpha, \beta)$ denote the minimum value of V_i on the closed annulus $\overline{B(\beta)} - B(\alpha)$. Pick $R_0 < R$ so that none of the f_i can jump out of $B(R)$ in one step. Pick $r_i < R_0$ such that in $B(r_i)$ we have $V_i < m_i(R_0, R)$. This choice is possible via the continuity of V_i . Let $r = \min(r_i)$. With this choice, if we start in $B(r)$, either equation alone will stay within $B(R)$.

Pick $r_0 < r$ so that none of the f_i can jump out of $B(r)$ in one step. Now, pick $\rho_i < r_0$ such that in $B(\rho_i)$ we have $V_i < m_i(r_0, r)$. Set $\rho = \min(\rho_i)$. Thus, if we start in $B(\rho)$, either equation alone will stay in $B(r_0)$, and hence $B(r)$. Therefore, whenever the other is first switched on we have $V_i(x(t_1)) < m_i(R_0, R)$, so that we will stay within $B(R_0)$, and hence $B(R)$.

The proofs for general N require N sets of concentric circles constructed as the two were in each case above. ■

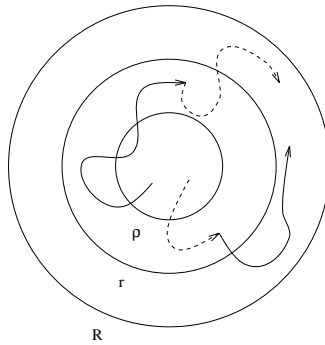

Figure 12: Multiple Lyapunov stability, $N = 2$.

Some remarks are in order:

- The case $N = 1$ is the usual theorem for Lyapunov stability (cf. Luenberger). Also, compare Figures 1 and 12, both of which depict the continuous-time case. Also, compare Figures 2 and 11 which depict a Lyapunov function (upper right) and multiple Lyapunov functions over time, respectively.
- The theorem also holds if the f_q are time-varying.
- It is easy to see that the theorem does not hold if $N = \infty$, and we leave it to the reader to construct examples.
- It is not hard to generalize our MLF theory to the case of different equilibria, which is generally the case in hybrid systems. For example, under a Lyapunov-like switching rule, after all controllers have been switched in at level α_i , the set $\bigcup_i V_i^{-1}(\alpha_i)$ is invariant.
- It is not hard to extend the presented theorems to consider variations such as (1) relaxing *the first part* of our Lyapunov-like definition by allowing the Lyapunov functions to increase in each active region if the gain from “switch in” to “switch out” is given by a positive definite function (as in Ye *et al.*), or, more provocatively, (2) allowing increases over energy V_i at its switching times with a similar constraint from initial value to final limit.
- The result above generalizes some theorems in the literature, including those of Peleties-DeCarlo (see below) and Pavlidis. In the latter, Pavlidis concludes stability of differential equations containing impulses by introducing a positive definite function which decreases during the occurrence of an impulse and remains constant or decreases during the “free motion” of the system. Hence, it is a special case of our results.

- The stabilization strategies proposed by Malmberg *et al.*, e.g., choosing at each time the minimum of several Lyapunov functions, clearly satisfies our switching condition.
- It is possible that some types of sliding mode behavior may be taken care of in this way by defining each sliding mode and its associated sliding dynamics as an additional system to which we can switch. We then merely check the conditions as before.
- In proving stability, we can use more Lyapunov functions than constituent systems (see Pettersson and Lennartson for an example where this is necessary) by simply introducing new discrete sub-states with the same continuous dynamics but different Lyapunov functions.
- When the dynamics are piecewise affine, computational tests may be used to compute appropriate switching conditions (Peleties and DeCarlo's eigenvalue analysis) or to find Multiple Lyapunov functions that prove stability (using LMIs).

Example 17 Pick any line through the origin. Going back to Example 7 and choosing to use f_1 above the line and f_2 below it, the resulting system is globally asymptotically stable. See Figure 13, which plots one second of a trajectory for the switched system starting from (1,1). While stability may be clear from the figure, we can prove it using our theorem. The reason is that each system is an asymptotically stable linear system and hence diminishes $V_i = x^T P_i x$ for some $P_i > 0$ (cf. Luenberger). However, since switchings occur on a line through the origin, we are assured that on switches to system i , V_i is at a lower energy than when it was last switched out. Why? Assume we switch from f_j to f_i at the point y . At that point, $V_i(y) = y^T P_i y$ and $V_j(y) = y^T P_j y$. At the next switch point, z , we go from f_j to f_i . There, since V_j is Lyapunov-like for f_j , we have

$$V_j(z) = z^T P_j z < y^T P_j y = V_j(y). \quad (20)$$

However, since the switching line is the origin, $z = \alpha y$. Further, from Equation (20), we know that $\alpha^2 < 1$. Thus, we have that

$$V_i(z) = z^T P_i z = \alpha^2 y^T P_i y < y^T P_i y = V_i(y), \quad (21)$$

which satisfies our theorem. ◇

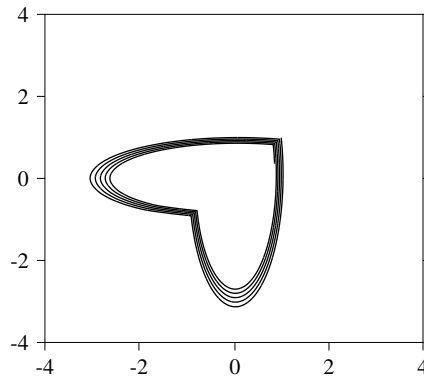

Figure 13: Switching on a line through the origin. Motion is clockwise.

Example 18 Consider the following system, inspired from one by Pettersson and Lennartson: $\dot{x}(t) = A_{i(t)}x(t)$ with

$$A_1 = \begin{bmatrix} -1 & -100 \\ 10 & -1 \end{bmatrix}, \quad A_2 = \begin{bmatrix} 1 & 10 \\ -100 & 1 \end{bmatrix}. \quad (22)$$

with the switching rule that we go from system i to j on hitting the sets $c_{i,j}^T x(t) = 0$ in the second and fourth quadrants where

$$c_{1,2} = [4, 3], \quad c_{2,1} = [3, 4]. \quad (23)$$

An example trajectory is shown in Figure 14. There, the dynamics alternate between going counter-clockwise along a short, fat ellipse and then clockwise along a tall, skinny one.

It is clear that the conic switching region (1) is attractive, (2) leads to a hybrid system, and (3) admits no single Lyapunov function (depending only on the continuous state) that can be used to show stability (because the system's trajectories intersect themselves).

However, it is also easy to see that energy is decreasing at switching times (just consider the switching lines through the origin and note we get closer). Multiple Lyapunov functions showing this may be computed using LMIs which encode the conditions of our theorem above (cf. Johansson and Rantzer). \diamond

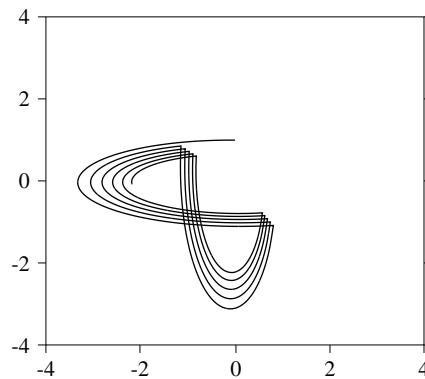

Figure 14: A switching system requiring hybrid states and MLFs. Motion is counter-clockwise.

It is possible to use different conditions on the V_q to ensure stability. For instance, consider the following

Definition 19 If there are candidate Lyapunov functions V_q corresponding to f_q for all q , we say they satisfy the sequence nonincreasing condition for a trajectory $x(\cdot)$ if

$$V_{q_{j+1}}(x(t_{j+1})) < V_{q_j}(x(t_j)). \quad (24)$$

This is a stronger notion than the Lyapunov-like condition used above.

The sequence nonincreasing condition is used in the stability (version of the asymptotic stability) theorem of Peleties and DeCarlo. Thus that theorem is a special case of the continuous-time version of Theorem 16 above. Moreover, the proof of asymptotic stability in Peleties and DeCarlo is flawed since it only proves state convergence and not state convergence plus stability, as required. It can be fixed using our theorem.

Now, consider the case where the index set is an arbitrary compact set:

$$\dot{x} = f(x, \lambda), \quad \lambda \in K, \text{ compact.} \quad (25)$$

Here, $x \in R^n$ and f is globally Lipschitz in x , continuous in λ . For brevity, we only consider the continuous-time case. Again, we assume finite switches in finite time.

As above, we may define a switching sequence $S = x_0; (\lambda_0, t_0), (\lambda_1, t_1), \dots, (\lambda_N, t_N), \dots$ with its associated projection sequences.

Theorem 20 *Suppose we have candidate Lyapunov functions $V_\lambda \equiv V(\cdot, \lambda)$ and vector fields as in Equation (25) with $f(0, \lambda) = 0$, for each $\lambda \in K$. Also, $V : R^n \times K \rightarrow R^+$ is continuous. Let S be the set of all switching sequences associated with the system.*

If for each $S \in \mathcal{S}$ we have that for all q , V_λ is Lyapunov-like function for f_λ and $x_S(\cdot)$ over $S|\lambda$, and the V_λ satisfy the sequence nonincreasing condition for $x_S(\cdot)$, then the system is stable in the sense of Lyapunov.

This theorem is a different generalization of the aforementioned theorem in Peleties and DeCarlo.

4. Further Results

The multiple Lyapunov method of the previous section can be used to prove the correctness of hybrid stabilization schemes discussed in the literature, such as those due to Artstein and Malmberg *et al.* In particular, the stabilization strategies proposed of Malmberg *et al.*, e.g., choosing at each time the minimum of several Lyapunov functions, clearly satisfies our switching condition. Theoretical extensions follow: (1) In proving stability, it is sometimes necessary to use more Lyapunov functions than constituent systems (cf. Pettersson and Lennartson). This extension is covered by the theorems above, however, by simply introducing new discrete sub-states with the same continuous dynamics but different Lyapunov functions. (2) In Ye *et al.*, the *character* of the theorems is to effectively relax the first part of our Lyapunov-like definition by allowing the Lyapunov functions to increase in each active region if the gain from “switch in” to “switch out” is given by a positive definite function. This is certainly allowed as the definition of Lyapunov stability allows one to pick a strictly smaller neighborhood of initial conditions in staying within a given one. More provocatively, then, one may formulate relaxations allowing increases over energy V_q at switching times with a similar constraint from initial value to final limit.

We now go to the case of hybrid systems with fixed instants of impulse effect. We review some theorems of Barabanov and Starozhilov and give some corollaries encompassing results of Hou *et*

al. and Rui *et al.*. Barabanov and Starozhilov consider the stability of class of “continuous-discrete systems.” To be specific, these are systems with fixed instants of impulse effect, as described in the Introduction. Focusing on systems with linear dynamics, linear impulses, and periodic instants of impulse effect, they prove several stability results, including a necessary and sufficient Lyapunov (second method) theorem. With this in hand, they turn to consider stability and instability by first approximation. In particular, they consider the system of equations

$$\begin{aligned}\dot{z} &= A_1 z + f(z, t), & t \in I/\Theta, \\ z(t^+) &= A_2 z(t) + \phi(z(t), t), & t \in \Theta,\end{aligned}\tag{26}$$

where $z \in R^n$, A_1 and A_2 are constant $n \times n$ matrices, $\Theta = \{t_k \mid t_k = kh, h > 0, k = 1, 2, \dots\}$, and the function $f(z, t) : \Omega_0 \times I \rightarrow R^n$ is continuous in z in the region Ω_0 for any $t \in \Theta$. Furthermore, $f(0, t) = 0, t \in I, \phi(0, t) = 0, t \in \Theta$ and for $z', z'' \in \Omega_0$, the conditions

$$\|f(z', t) - f(z'', t)\| \leq L_1 \|z' - z''\|^{1+\alpha}; L_1, \alpha > 0, t \in I,\tag{27}$$

$$\|\phi(z', t) - \phi(z'', t)\| \leq L_2 \|z' - z''\|^{1+\alpha}; L_2, \alpha > 0, t \in \Theta,\tag{28}$$

hold. Finally, they define

$$P = A_2 \exp\{A_1 h\}.\tag{29}$$

Using inequalities and lemmas derived in their paper, they conclude the following

Theorem 21 (Theorem 5, Barabanov and Starozhilov) *If P is Schur (i.e., the eigenvalues of the matrix P are such that $|\lambda_i(P)| < 1, i = 1, \dots, n$), then the zeroth solution of Equation (26) is asymptotically stable.*

Theorem 22 (Theorem 6, Barabanov and Starozhilov) *If P is strictly not Schur (i.e., $|\lambda_i(P)| > 1$ for even one eigenvalue of the matrix P), then the zeroth solution of Equation (26) is unstable.*

Now suppose we want to apply the above theorems in the case of hybrid systems of the following form,

$$\begin{aligned}\dot{x} &= Ax + Bq + f(x, q), & t \in [kT, (k+1)T) \\ q(t^+) &= Cx + Dq + \phi(x(t), q), & t \in kT, k = 0, 1, 2, \dots\end{aligned}\tag{30}$$

where f, ϕ have properties as defined above and all unspecified variables are evaluated at time t . Comparing to the foregoing, we may simply compute for this special case:

$$z = \begin{bmatrix} x \\ q \end{bmatrix},\tag{31}$$

$$A_1 = \begin{bmatrix} A & B \\ 0 & 0 \end{bmatrix},\tag{32}$$

$$A_2 = \begin{bmatrix} I & 0 \\ C & D \end{bmatrix}.\tag{33}$$

In this case, the matrix P defined above computes to

$$P = \begin{bmatrix} e^{AT} & \tilde{B} \\ Ce^{AT} & C\tilde{B} + D \end{bmatrix} \equiv H, \quad (34)$$

where $\tilde{B} = \int_0^T e^{A(T-\tau)} d\tau B \equiv E(T)B$.

Corollary 23 *If H is Schur, then the zeroth solution of Equation (30) is asymptotically stable.*

Corollary 24 *If H is strictly not Schur, then the zeroth solution of Equation (30) is unstable.*

4.1. Applications

Let us now consider the following *nonlinear sampled-data system*, as defined in Hou *et al.*:

$$\begin{aligned} \dot{x} &= f(x(t)) + Bu(k), & t \in [k, k+1), \\ u(k+1) &= \tilde{C}u(k) + \tilde{D}x(k), & k = 0, 1, 2, \dots \end{aligned} \quad (35)$$

where $f(0) = 0$. First, let A denote the Jacobian of f evaluated at $x = 0$, $T = 1$, and $q(k) = u(k)$. Thus, converting to the form of Equation (30) above, the nonlinear sampled-data system becomes

$$\begin{aligned} \dot{x} &= Ax + Bq + \tilde{f}(x), & t \in [k, k+1), \\ q(k) &= \tilde{C}q(k-1) + \tilde{D}x(k-1), & k = 0, 1, 2, \dots \end{aligned} \quad (36)$$

But, we may compute from the first of these equations that

$$x(k-1) = e^{-A}x(k) - e^{-A}E(1)Bq(k-1). \quad (37)$$

where $E(1) = \int_0^1 e^{A(1-\tau)} d\tau$. Hence, the shift of time and matrix notation means we can convert this into a special case of Equation (30) with

$$C = \tilde{D}e^{-A}, \quad (38)$$

$$D = \tilde{C} - \tilde{D}e^{-A}E(1)B. \quad (39)$$

By our corollaries above, stability of Equation (35) comes down to examining Schur-ness of

$$H = \begin{bmatrix} e^A & E(1)B \\ \tilde{D} & \tilde{C} \end{bmatrix}. \quad (40)$$

This is exactly the matrix in Equation (6) of Hou *et al.*. Hence, one sees that Corollaries 23 and 24 encompass Theorems 1 and 2 of Hou *et al.* as special cases.

As another application of the corollaries above, we consider the following *general hybrid system*, as defined by Rui *et al.*:

$$\dot{x} = g(x(t), x(kT)), \quad t \in [kT, (k+1)T), \quad (41)$$

where $g : R^{2n} \rightarrow R$ is continuously differentiable with $g(0, 0) = 0$. Hence we may represent g as

$$g(x, z) = Ax + Bz + \tilde{g}(x, z), \quad (42)$$

where A and B are the Jacobian matrices at $(0, 0)$ with respect to x and z , respectively. Thus, setting $q(kT) = x(kT)$, we have a special case of Equation (30) with

$$C = I, \quad (43)$$

$$D = 0. \quad (44)$$

So, H of our corollaries reduces in this case to

$$\begin{bmatrix} e^{AT} & \tilde{B} \\ e^{AT} & \tilde{B} \end{bmatrix}, \quad (45)$$

which is Schur if $e^{AT} + \tilde{B}$ is Schur. Thus, Theorem 1 of Rui *et al.* is also a special case of the Corollary 23.

Notes and Acknowledgments

The reader is directed to the review papers by Branicky, DeCarlo *et al.*, and Liberzon for more details and references on the topic of stability of hybrid systems. An alternative approaches for hybrid systems stability may be found in Goncalves *et al.* The author is grateful to the reviewers for helpful comments and to Prof. H. Unbehauen for the opportunity to contribute to the EOLSS.

Bibliography

Alur R., Henzinger T.A., and Sontag E.D., Eds. (1996). *Hybrid Systems III*. Springer, NY. [A volume of hybrid systems papers.]

Artstein Z. (1996). Examples of stabilization with hybrid feedback. In , 173–185. [The article that introduced the hybrid automaton model depicted in Figure 5.]

Åström K.J. (1968). Course notes on nonlinear systems. Lund Institute of Technology. [An early volume that mentions switching.]

- Bainov D.D. and Simeonov P.S. (1989). *Systems with Impulse Effect*. Chichester, England: Ellis Horwood. [A complete book, replete with rigorous stability results for continuous systems that are also subject to impulses.]
- Barabanov A.T. and Starozhilov Y.F. (1988), Investigation of the stability of continuous discrete systems by Lyapunov's second method. *Sov. J. Autom. Inf. Sci.*, 21(6):35–41. [An article containing linearization results for hybrid systems.]
- Branicky M.S. (1994). Stability of switched and hybrid systems. *Proc. IEEE Conf. on Decision and Control*, pp. 3498–3503, Lake Buena Vista, FL. [The article that introduced Multiple Lyapunov functions.]
- Branicky M.S. (1995). *Studies in Hybrid Systems: Modeling, Analysis, and Control*. Sc.D. thesis. EECS Dept., M.I.T., Cambridge, MA. [A thesis devoted to hybrid systems.]
- Branicky M.S. (1998). Multiple Lyapunov functions and other analysis tools for switched and hybrid systems. *IEEE Trans. Automatic Control*, 43(4):475–482. [A journal article on Multiple Lyapunov functions.]
- Branicky M.S. (1997). Stability of hybrid systems: State of the art. *Proc. IEEE Conf. on Decision and Control*, pp. 120-125, San Diego, CA, Dec. 1997. [An early article surveying stability tools for hybrid systems.]
- DeCarlo R., Branicky M.S., Pettersson S., and Lennartson B. (2000). Perspectives and results on the stability and stabilizability of hybrid systems. *Proceedings of the IEEE*, 88(2):1069–1082. [A wide-ranging article surveying stability results and computational tools for hybrid systems.]
- Ezzine J. and Haddad A.H. (1989). Controllability and observability of hybrid systems. *International Journal of Control*, 49(6):2045–2055. [An article giving sufficient conditions for the stability of switched linear systems.]
- Feron E. (1995). Quadratic stabilizability of switched systems via state and output feedback. Technical report CICS-P-468, Center for Intelligent Control Systems, Mass. Inst. of Tech. [An article giving necessary and sufficient conditions for the stability of switching among two linear systems.]
- Goncalves J., Megretski A., and Dahleh M. (2000). Global stability of relay feedback systems. *IEEE Transactions on Automatic Control*, 46(4): 550-562. [An article presenting a complimentary approach to hybrid systems stability, based on Poincare return maps.]
- Hou L., Michel A.N., and Hui Y. (1996). Some qualitative properties of sampled-data control systems. In *Proc. IEEE Conf. on Decision and Control*, pp. 911–916, Kobe, Japan. [An article giving sufficient conditions for the stability of sampled-date controllers.]
- Johansson M. and Rantzer A. (1998). Computation of piecewise quadratic Lyapunov functions for hybrid systems. *IEEE Transactions on Automatic Control*, 43(4):555–559. [An article presenting a computational tool for analyzing the stability of switched linear systems.]
- Liberzon D. and Morse A.S. (1999). Basic problems in stability and design of switched systems. *IEEE Control Systems Magazine*, 19(5):59–70. [An article surveying results for switched systems.]
- Luenberger D.G. (1979). *Introduction to Dynamic Systems*. New York: Wiley and Sons. [A general dynamical systems text, covering Lyapunov stability.]
- Malmberg J., Bernhardsson B., and Åström K.J. (1996). A stabilizing switching scheme for multi-controller systems. In *Proc. IFAC World Congress*, San Francisco. [An article that presented an algorithm for switching among systems in order to achieve stability.]

- Pavlidis T. (1967). Stability of systems described by differential equations containing impulses. *IEEE Trans. Automatic Control*, T-AC-12(1): 43–45. [An early article dealing with stability of systems with impulses.]
- Peleties P. and DeCarlo R. (1991). Asymptotic stability of m -switched systems using Lyapunov-like functions. In *Proc. American Control Conf.*, pp. 1679–1684, Boston. [An article that presented an algorithm for switching among linear systems in order to achieve stability.]
- Pettersson S. and Lennartson B. (1996). Modelling, analysis, and synthesis of hybrid systems. In *Preprints of the Reglermöte*, Lulea, Sweden. [An article that presents some illustrative switching systems.]
- Rui C., Kolmanovsky I., and McClamroch N.H. (1997). Hybrid control for stabilization of a class of cascade nonlinear systems. In *Proc. American Control Conf.*, pp. 2800–2804, Albuquerque, NM. [An article giving sufficient conditions for the stability of sampled-date controllers.]
- Utkin V.I. (1977). Variable structure systems with sliding modes. *IEEE Trans. Automatic Control*, 22(2):212–222. [An early article on switched systems.]
- Vidyasagar M. (1993). *Nonlinear Systems Analysis*. Englewood Cliffs, NJ: Prentice Hall. Second edition. [A general nonlinear systems text, covering Lyapunov stability.]
- Wicks M.A., Peleties P., and DeCarlo R.A. (1994). Construction of piecewise Lyapunov functions for stabilizing switched systems. In *Proc. IEEE Conf. Decision and Control*, pp. 3492–3497, Lake Buena Vista, FL. [An article that presented linear algebraic tools to compute switching among linear systems that achieve stability.]
- Ye H., Michel A., and Wang K. (1995). Stability theory for hybrid dynamical systems. In *Proc. IEEE Conf. Decision and Control*, New Orleans. [An article presenting a generic stability theory for a very general class of hybrid systems.]