

Comparative Study of OFCDM and MC-DS-CDMA with MMSE MUD and Iterative Decoding

Akram J. Awad, Timothy O'Farrell

Institute of Integrated Information Systems (I3S)

School of Electronic and Electrical Engineering, University of Leeds, LS2 9JT, UK

eenajma@leeds.ac.uk

Abstract - In this contribution we study and compare the performance of orthogonal frequency code division multiplexing (OFCDM) and multi-carrier direct-sequence code division multiple access (MC-DS-CDMA) based on MMSE multi-user detection (MUD) for the forward link of a cellular mobile system with the use of turbo channel coding and iterative decoding. The BER and PER results for both systems show better performance for MC-DS-CDMA when no channel coding is used or when the number of decoding iterations is low, while the performance of both systems converge at a higher number of decoding iterations.

1. Introduction

Extensive research is currently ongoing with the goal of fulfilling the requirements of the next or fourth generation (4G) mobile communications systems. From the literature, the strongest candidates for the physical layer of the system are a combination of orthogonal frequency division multiplexing (OFDM) and code division multiple access (CDMA). Multi-carrier CDMA (MC-CDMA), Multi-carrier Direct-Sequence CDMA (MD-DS-CDMA) and Orthogonal Frequency Code Division Multiplexing (OFCDM) are among these proposed combinations [1-2].

MC-CDMA spreads the chips of one symbol over different subcarriers in the frequency domain, either adjacent to each other or interleaved throughout the whole system bandwidth [3]. Chip interleaving maximises the frequency domain diversity exploitation at the expense of multiple-access interference (MAI), while bit interleaving achieves low MAI levels at the expense of frequency diversity. MC-DS-CDMA is more generalised as it employs both time and frequency spreading (called TF-domain spreading) [4,5]. Time-domain spreading is invoked to increase the achievable processing gain associated with each subcarrier signal, while the frequency domain spreading across several subcarriers is employed to further increase the total attainable processing gain.

Although orthogonal frequency and code division multiplexing (OFCDM) was first introduced as solely based on MC-CDMA where the spreading of chips takes place in the frequency domain, the concept was taken further in [2] to include time domain spreading. In [6-8], Variable-Spreading Factor OFCDM (VSF-OFCDM) was investigated as the core technology for the 4G's downlink interface.

In this paper, both systems, OFCDM and MC-DS-CDMA, are studied in a single-cell simulation environment for the downlink. The performance of both systems with and without turbo channel coding is presented and discussed. The rest of the paper is outlined as follows: in section 2 system models for both OFCDM and MC-DS-CDMA are described. Section 3 describes the system configurations and the channel model used. The simulation results are presented and discussed in Section 4, and finally Section 5 concludes the paper.

2. System Description

2.1 OFCDM

As shown in figure (1), which illustrates the OFCDM downlink's transmitter and receiver structure, after channel encoding, bit interleaving and mapping are applied, N_c symbols are serial-to-parallel (S/P) converted. The new symbol duration after conversion is $T_c = T_s \times N_c$, where T_s is the original symbol period before S/P conversion and N_c is the number of subcarriers. Each symbol is then duplicated into SF serial copies, where SF is the spreading factor in the time domain, and each of these copies is multiplied by one of the SF chips of the spreading code assigned for the user. After multiplexing the symbols of C_{max} users, the resultant N_c parallel sequences are converted into an OFCDM frame using the Inverse Fast Fourier Transform (IFFT) and followed by the insertion of the guard interval of period T_g after every chip. The chip duration is now equal to T_c and the new symbol duration becomes $T = T_c' \times SF$, where $T_c' = T_c + T_g$. The output is then transmitted over the corresponding N_c subcarriers.

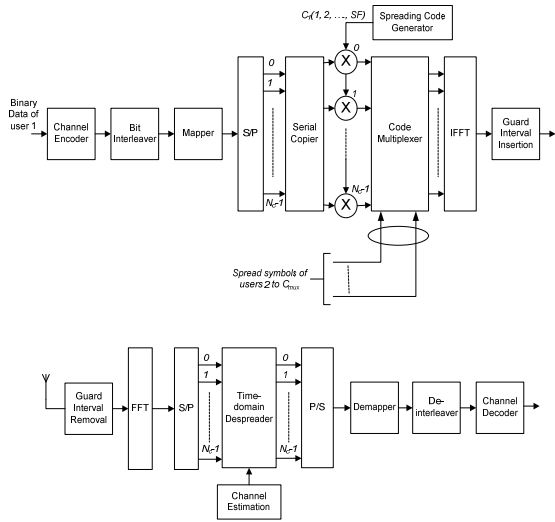

Figure 1 OFCDM system model

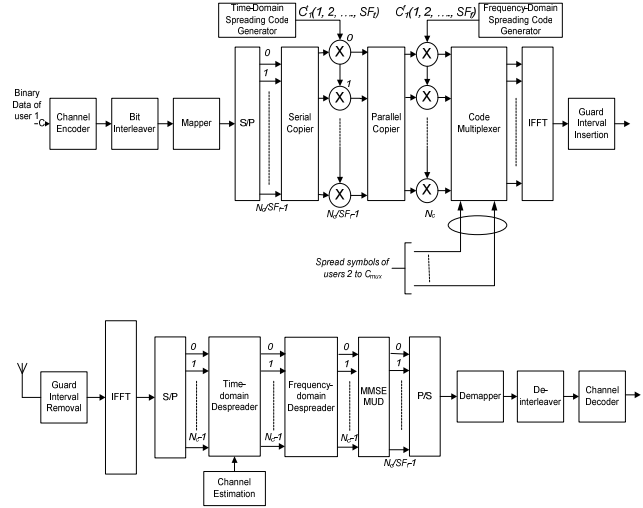

Figure 2 MC-DS-CDMA system model

The subcarrier bandwidth in OFCDM is narrow enough to ensure that every subcarrier is affected by flat fading even in the worse delay conditions. Thus at the receiver, the received signal after FFT can be expressed in the frequency domain as:

$$R_g = C^T B H + N \quad (1)$$

where C is a $C_{max} \times SF$ matrix containing the spreading codes in use. B is the $C_{max} \times N_c$ matrix of the data symbols corresponding to all active users and transmitted in one OFCDM frame, and it is given by:

$$B = \begin{bmatrix} b_{1,1} & \dots & \dots & \dots & b_{1,N_c} \\ \vdots & \ddots & & & \vdots \\ \vdots & & \ddots & & \vdots \\ \vdots & & & \ddots & \vdots \\ b_{c_{max},1} & \dots & \dots & \dots & b_{c_{max},N_c} \end{bmatrix} \quad (2)$$

where $b_{n,k}$ is the symbol corresponding to the n -th user and k -th subcarrier. The term X^T denotes the non-conjugate transpose function. H is the diagonal channel matrix for the received signal and N is the $SF \times N_c$ Additive White Gaussian Noise (AWGN) matrix with zero mean and double-sided power spectral density of $\frac{N_0}{2}$.

The signal is multiplied by the conjugate of the channel response at each subcarrier to correct its phase and weight the signal according to its signal-to-noise ratio (SNR). As the channel is assumed to be fixed over at least one symbol period T , there will be no MAI amongst users when orthogonal spreading codes are used; therefore despreading and combining do not need any further equalisation or weighting. The resultant can then be sent to the modulation demapper from which soft output values are fed to the deinterleaver and iteratively decoded by the turbo decoder to get an estimation of the transmitted bits.

2.2 MC-DS-CDMA

As shown in figure (2), in MC-DS-CDMA $\frac{N_c}{SF_f}$ data symbols are S/P converted, where SF_f is the spreading factor in the frequency domain. Every symbol is then spread in the time domain using the user-assigned spreading code with spreading factor SF_f . Thus the total bandwidth of every subcarrier is expanded and the chip duration is now $T_c = \frac{T_s}{SF_f}$ where T_s is the symbol duration. Each of the spread symbols is copied SF_f times so that the total number of symbol copies available to modulate the subcarriers is equal to N_c . The next step is to multiply each of the spread symbol copies corresponding to one symbol, or the relative symbols, by one chip of another code with length SF_f assigned to the users. The copies of every symbol are interleaved across the frequency domain so that the maximum possible distance is assumed between any two relevant symbol copies. With these settings the subcarriers corresponding to one symbol are much less likely to have any correlation in their fading characteristics. All symbols transmitted in parallel are multiplied with the same code; in other words,

the code is used $\frac{N_c}{SF_f}$ times in every frame. After multiplying the data of all users, the new N_c chipped symbols transmitted in parallel form one MC-DS-CDMA frame using the IFFT where every symbol is carried on one subcarrier.

Similar to OFCDM, the subcarrier bandwidth and spacing in MC-DS-CDMA are set such that no ISI affects the subcarriers. The same assumption that all the chips on one subcarrier within a frame are faded simultaneously is also valid here. At the receiver, the received signal corresponding to the l -th transmitted symbol can be represented as:

$$R_l = X_l H_l + N_l \quad l=1,2,\dots,\frac{N_c}{SF_f} \quad (3)$$

where X_l is an $SF_l \times SF_f$ matrix representing the symbols spread over the l -th group of subcarriers in the frequency domain and over SF_l chips in the time domain, and is given by:

$$X_l = \begin{bmatrix} X_l[1,1] & \dots & \dots & \dots & X_l[1,SF_f] \\ \vdots & \ddots & & & \vdots \\ \vdots & & \ddots & & \vdots \\ \vdots & & & \ddots & \vdots \\ X_l[SF_l,1] & \dots & \dots & \dots & X_l[SF_l,SF_f] \end{bmatrix} \quad (4)$$

and

$$X_l[m,k] = \sum_{n=1}^{C_{max}} C_n^t[m] C_n^f[k] b_{n,l} \quad (5)$$

where $b_{n,l}$ is the data symbol corresponding to user n and transmitted over the l -th group of subcarriers. $C_n^t[m]$ and $C_n^f[k]$ are the m -th chip of the time-domain spreading code and the k -th chip of the frequency domain spreading code, respectively, assigned to user n . H_l is the diagonal channel matrix for the signal received on subcarrier group l , and N_l is the $SF_l \times SF_f$ Additive White Gaussian Noise (AWGN) matrix with zero mean and double-sided power spectral density of $\frac{N_0}{2}$.

Similar to OFCDM, the signal is multiplied by the conjugate of H_l for phase correction and SNR weighting. As the channel is assumed to be stationary during one symbol period, i.e. throughout the time-domain code period, the weight of the signal will not affect the time-domain despreading. The codes in use have zero cross correlation and thus despreading the signal in the time domain will eliminate all the interference from users that do not share the same time-domain spreading code with the wanted user signal.

The signal is then despread in the frequency domain where the orthogonality between codes is broken due to the frequency selective fading across the code chips. The despreading is first done by multiplying the signal with the frequency-domain code matrix. The next step is to detect the wanted user signal using MMSE multiuser detection (MUD) which provides a trade-off between MAI and noise amplification. After despreading in both the time and frequency domains, the resultant can be sent to the demapper; soft outputs are deinterleaved and forwarded to the turbo channel decoder to estimate the actual transmitted data bits.

3. System Configuration

The channel model used is similar to that suggested in [8] which is a 24-path Rayleigh-faded channel with an exponential decay of the paths' average power levels. In the simulation results presented in this paper, a fixed delay of 0.3 μ sec was used. The guard interval is set so that it is always longer than the delay of the channel. The main parameters of the two systems under investigation are summarised in table (1).

4. Simulation Results

Figures (3) and (4) present the BER and PER simulation results for OFCDM and MC-DS-CDMA in a single-cell environment with spreading factors (time x frequency) of (8x1) and (1x8), respectively. The figures show the performance of both coded and uncoded systems with the number of decoding iterations = 1,2 and 6. It can be seen from results that because OFCDM has no frequency diversity to exploit, its performance is highly dependent on the existence of channel coding to improve its performance. When the number of decoding iterations exceeds 2 the performance of both OFCDM and MC-DS-CDMA does not improve considerably. The trend of OFCDM's performance shows that the BER and PER decrease at a slower rate compared with the fast improvement of MC-DS-CDMA at high SNR values.

	OFCDM	MC-DS-CDMA
Bandwidth	101.5 MHz	100.5 MHz
Subcarrier Spacing	131.836 kHz	500 KHz
Guard Interval	1.674 μ Sec.	0.500 μ Sec.
Number of Subcarriers (N_c)	768	200
Spreading Code	Walsh-Hadamard	
Scrambling Code	Pseudo random	
Spreading Factor	$SF_{time}=8, SF_{Frequency}=1$	$SF_{time}=1, SF_{Frequency}=8$
Modulation	QPSK	
Coding/Decoding	Turbo coding (R=1/2, K=4, generator polynomials g0=13 and g1=15 (in octal)) Max-Log-MAP decoding	
Interleaving	Bit Interleaving	Bit+Subcarrier Interleaving
User Detection	Single	MUD (MMSE)

Table 1 Simulation system parameters

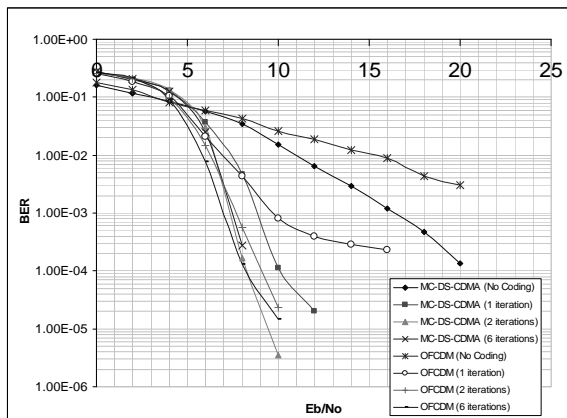

Figure 3 BER performance of MC-DS-CDMA and OFCDM

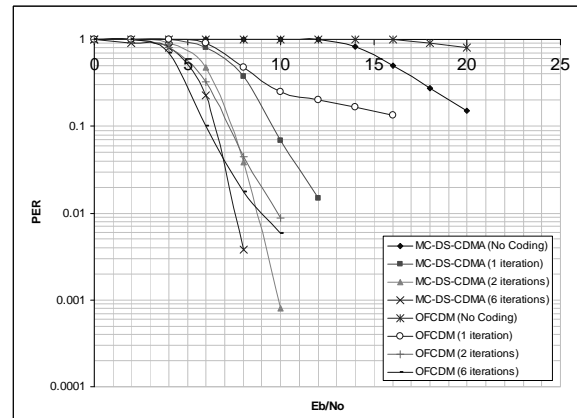

Figure 4 PER performance of MC-DS-CDMA and OFCDM

5. Conclusions

In this work the performance of OFCDM and the 2-dimensional MC-DS-CDMA were studied and compared in the single-cell environment as candidates for the next generation mobile communications system. It can be concluded that MC-DS-CDMA performs better than OFCDM in uncoded systems. Furthermore, MC-DS-CDMA is superior to OFCDM in channel-coded systems although the difference between their performances decreases as the number of decoding iterations exceeds 2 iterations.

References

- [1] R. V. Nee and R. Prasad, *OFDM for Wireless Multimedia Communications*: Artech House Publishers, 2000.
- [2] A. Matsumoto, K. Miyoshi, M. Uesugi, and O. Kato, "A study on time domain spreading for OFCDM," presented at Wireless Personal Multimedia Communications, 2002. The 5th International Symposium on, 2002.
- [3] N. Maeda, H. Atarashi, and M. Sawahashi, "Performance Comparison of channel interleaving methods in frequency domain for VSF-OFCDM broadband wireless access in forward link," *IEICE Trans. Communications*, vol. E86-B, pp. 300-313, 2003.
- [4] H. Matsutani and M. Nakagawa, "Multi-carrier DS-CDMA using frequency spread coding," presented at Personal Wireless Communication, 1999 IEEE International Conference on, 1999.
- [5] L.-L. Yang, W. Hua, and L. Hanzo, "Multiuser detection in multicarrier CDMA systems employing both time-domain and frequency-domain spreading," presented at Personal, Indoor and Mobile Radio Communications, 2003. PIMRC 2003. 14th IEEE Proceedings on, 2003.
- [6] S. Abeta, H. Atarashi, and M. Sawahashi, "Broadband packet wireless access incorporating high-speed IP packet transmission," presented at Vehicular Technology Conference, 2002. Proceedings. VTC 2002-Fall. 2002 IEEE 56th, 2002.
- [7] N. Maeda, Y. Kishiyama, H. Atarashi, and M. Sawahashi, "Variable spreading factor-OFCDM with two dimensional spreading that prioritizes time domain spreading for forward link broadband wireless access," presented at Vehicular Technology Conference, 2003. VTC 2003-Spring. The 57th IEEE Semiannual, 2003.
- [8] H. Atarashi and M. Sawahashi, "Investigation of Inter-Carrier Interference due to Doppler Spread in OFCDM Broadband Packet Wireless Access," *IEICE Trans. Communications*, vol. E85-B, pp. 2684-2693, 2002.