

Investigation on Automation of Lathe Machine

Prakash N. Parmar¹, Prof. N. C. Mehta², Prof. Manish V. Trivedi³

¹Student of M.E. (CAD/CAM), ²Head of Department, Professor³, Department of Mechanical Engineering, Noble Engineering College, Junagadh, Gujarat, INDIA.

Abstract— Now a days, products can be produced by modern technology, which uses computer software, hardware and firm ware in industries. It is needed to use CNC lathe machine to get more accurate dimensions and irregular shape. So, CNC machines are becoming more and more important in modernized industrialization. There are many conventional lathe machines in our country. To build a new modern developed country, it is required to convert these conventional lathe machines into semi-automatic control lathe machine by retrofitting. Developing and changing into semi-automatic control lathe machine, there are three required portions, namely, mechanical electronics and hydraulic. In this project we convert the convention lathes which have 5ft bed length in to the semi-automatic lathe.

In mechanical side we replace the ball screw in place of lead screw for better accuracy and remove some unnecessary component like gears for providing space for motors. We add an extra plates or structure for installation of motors. Also provides a hydraulic circuit for coolant. In electronic side we used a servo/ stepper motor for both Z and X axis and provide controller for the efficient operation.

Keywords—Automation, Retrofitting, CNC Turning Center

I. INTRODUCTION

Retrofitting refers to the addition of new technology or features to older systems this definition gives an almost all information about the word retrofitting. When we say that retrofitting related to some component that mean we try to upgrade that component and improve their efficacy through a present technology.

But here we only talks about the retrofitting in lathe machine at time Retrofitting is the process of replacing the CNC, servo and spindle systems on an otherwise mechanically sound machine tool to extend its useful life. Rebuilding and remanufacturing typically include a CNC retrofit. The anticipated benefits include a lower cost investment than purchasing a new machine and an improvement in uptime and availability. But there are often other unanticipated benefits to retrofitting including lower energy costs, higher performance and a new level of manufacturing data accessibility.

Assuming the machine tool is generally in good shape mechanically, CNC retrofitting is typically the lowest cost solution to improve the overall performance of an older machine tool.

Though some electrical subassembly is often performed at the retrofitter's business location, most of the work can be completed at the machine site, avoiding costly machine rigging and transportation costs, and minimizing the time that the machine is out of commission.

Rebuilding typically includes the repair or replacement of some worn mechanical components such as ball screws, lubrication pumps, safety interlocks, guards, hoses, belts and electrical wiring. The rebuild is typically performed at the rebuilder's facility, so there may be additional transportation and rigging costs.

Remanufacturing goes a step further to repair or replace mechanical components to the original, as new, factory specification. It is likely that the machine will be completely disassembled, cleaned, inspected, repaired and painted. All pneumatic, hydraulic and electrical systems will be updated. The machine may also be modified or have mechanical accessories added to re-purpose it for a new application. Practically without exception, remanufacturing will take place at the remanufacturer's site.

The main objective of the retrofitting in lathe machine is to improve the existing conventional lathe machine to provide it features of CNC machine with very lower cost than the new CNC machine.

Rather than above main objective there also several objectives of the retrofitting which is given below

- To Increased productivity and improved control of machine.
- Far superior repeatability.
- To reduced machine downtime.
- Fast machining cycles.
- High accuracy, high feed-rate.
- To increased accuracy and part finished due to controller.
- User friendly programming and simulation software enables 3D graphic representation of job with automatic generation of G-Code.
- Eliminate additional tooling cost.
- The Up-gradation Package is less expensive and more readily justifiable.

II. LITERATURE REVIEW

In 1984, Department of Mechanical Engineering, IIT, New Delhi^[1], has taken a research topic named as “Machine tool failure data analysis for condition monitoring application”. With the development of modern manufacturing technology, Flexible Manufacturing Systems have become key equipment in factory automation. Machine tool is heart of the Flexible Manufacturing Systems. Ex example Lathe machine is the general type of machine tool used by almost all the FMSs. During the operation of this machine tool, different kinds of failures are faced by the industry. A systematic study of such failures can help in identifying the critical sub-system of these machine tools. This will be useful for identifying the condition monitoring needs of the machine tools. This deals with the identification of critical sub-system based on the failure data analysis for different type of machine tools.

Initially lathe has been classified into various sub-systems as shown in Figure. In the frequency of failures for each sub-system and failure modes have been considered for finding out the weakest sub-system. In analysis, failure frequency and downtime have been taken into consideration for deciding critical sub-systems of machine tools. It can be observed that the maximum failures took place in headstock and carriage sub-systems. These sub-systems face failures in components like gear, gearbox bearing, spindle bearing, clutch and cross-slide jib. Here it could be observed that the bearing failures cause longer downtime.

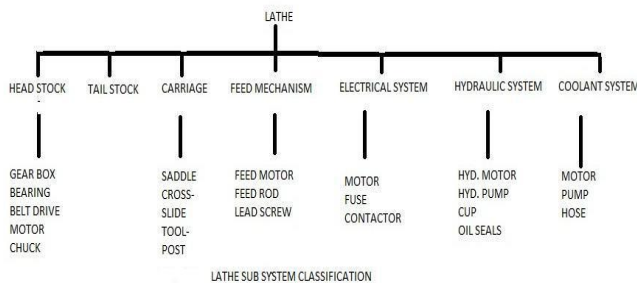

Wearing Parts of Conventional lathe

On histogram different failure modes and their relative failure frequencies have been grouped into four-failure modes, component damage, fuse burnt, circuit fault and looseness. It can be observed that the dominant failure mode is because of component damage. The components are electrical, electronics and of mechanical categories.

In 2013, V. Roy & S. Kumar^[2] from J institute Engineering, India published development of Lathe machine attachment for CNC machine.

He has developed attachment for an existing CNC machine. The CNC machine operates on mechatronic controls and a computer interface called CAMSOFT, and is used as a CNC Lathe after installing the respective attachment to it. He has design the attachment using CAD software & fabricated different model. He has successfully design & fabricated the model. The working of the CNC Lathe attachment is tested & checked by making proper machining operation like turning and thread cutting. The machining operations are successfully done. The CNC machine becomes multifunctional with the presently developed lathe attachment and can be used accordingly by installing the respective attachment to it. The CNC machine is useful for research work in both the fields, when installed with the proper attachment. The figure of developed attachment is shown below,



Fig. 1 Developed attachment

Developed design is successfully implemented in the proposed work for the development of the lathe attachment including headstock, tailstock and tool post. The work shows the process of the conceptual design and use of proper process planning for the development of the different components of the lathe attachment. The previously attachment and developed lathe attachment make the CNC machine multifunctional. Thus further research can be carried out in both the fields respectively. The CNC machine is based on the mechatronic controls and the computer interface CAMSOFT. Various lathe operations like plain turning, step turning, taper turning, arc turning, threading operations and manufacturing of a bolt are successfully performed on the CNC machine, when installed with lathe attachment. The successful development of the lathe attachment for the CNC machine is done.

In 2013, Karl-Heinz Schumacher^[3] is invented about Multi Spindle Lathe.

Multi spindle lathe comprising a machine frame as spindle drum which is arranged in the machine frame is rotatable about a spindle drum axis and is made up at least partially of segments which are cut out from flat material in a stacking direction parallel to the spindle drum axis and extend in stacking planes transverse to the stacking direction these segments having receiving cutouts and cooling channel cutouts which overlap with one another such that the spindle drum has spindle motor receptacles for spindle motors and a cooling channel system separated there from by wall webs characterized in that the cooling channel system has several channel subsystems for a liquid cooling medium which are fed in parallel.

In 2013, M. Moses & Dr. Denis Ashok^[4] M. Tech, Mechatronic from School of Mechanical and Building Science, VIT University, Vellore, India published titled as Development of a new machining setup for energy efficient turning process. In the production unit, lathe is one of the important production machines. This paper focuses on producing a quality product in lathe machine with less power consumption. In order to achieve that, a special setup is developed in the lathe machine for turning and finishing of the components, to achieve quality product and also to improve the productivity. As a result of this new approach, profuse amount of energy can be saved, quality product can be obtained and tool life can be increased. The study aimed at evaluating the best process environment which could simultaneously satisfy requirements of both quality and as well as productivity. By conducting many experiments it was found that this special setup process improves the quality and also reduces the power consumption as compared with the existing process.

Figure of developed attachment as shown below,

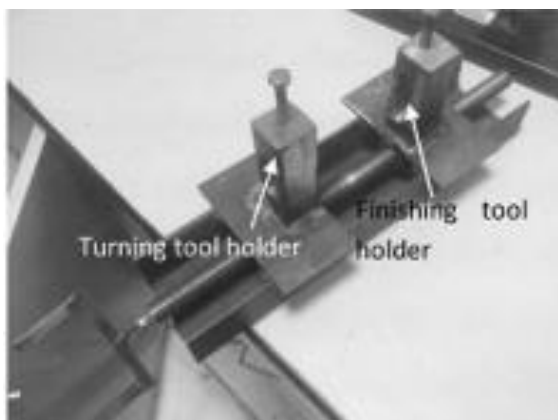

Fig. 2 Machine set up

He has concluded that the addition of surface finish tool in turning process helps to improve the surface finish and this setup increases the tool life of the turning tool. From the experimental results, it is confirmed that there is no change of power consumption even after the additional usage of surface finish tool. Hence, the set up will be helpful in improving the quality product, with lesser load and power consumption.

III. RETROFITTING PROCEDURE

Here I have divided the complete construction procedure into five steps. In which I have developed the complete Retrofitted lathe machine from conventional lathe machine. These all steps are listed below,

Step 1:- Purchasing of electronic parts

I have purchased electronic parts like stepper motor, stepper drive, spindle drive, proximity switch and control panel.

Step 2:- Disassemble some parts from conventional lathe machine

As per definition of retrofitting process, I have to remove non-used parts from conventional lathe machine. So I have removed Head stock gearing mechanism, Apron, Lead screw, Lead screw mounting bracket, Hand wheel, etc.

For decreasing friction on the slide and increasing such a part life I have used turcide which is made from poly tetra fluoro ethylene (PTFE) and bronze.

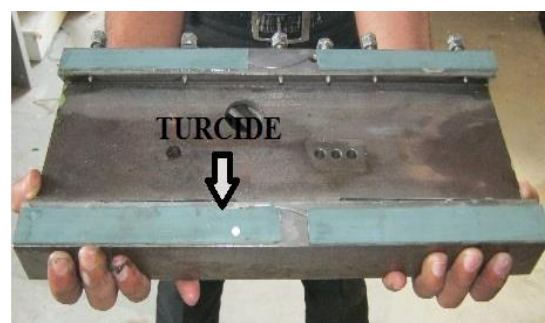

Fig. 3 Turcide on sliding portion

Step 3:- Dimensionally Design and fabrication of required mechanical parts

I have dimensionally design some parts which are required for retrofitting & fabricated and/or manufactured. Some of parts design are shown below,

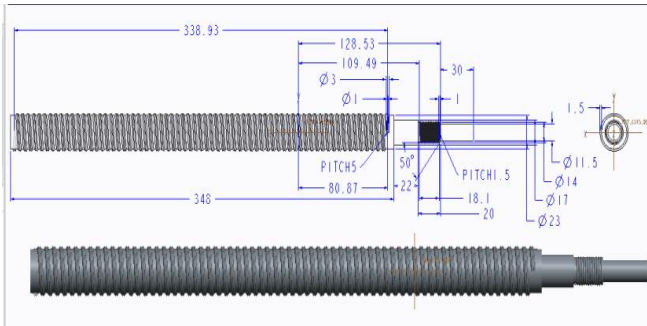

Fig. 4 Dimensionally design X-axis ball screw

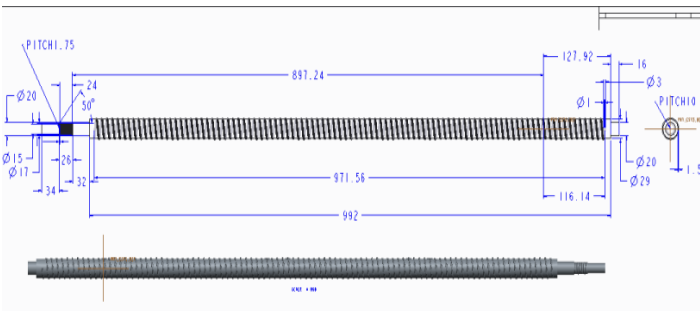

Fig. 5 Dimensionally design Z-axis ball screw

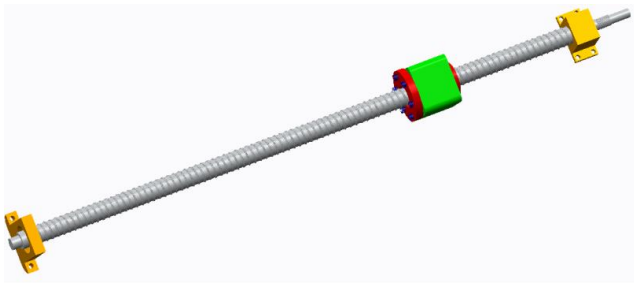

Fig. 6 Assembly of Z-axis ball screw with bracket

Step 4:- Assemble all manufactured parts & electronics parts at desired place

After manufacturing and/or fabricating all required parts, assembly procedure carried out. All the mechanical & electronics parts are attached to their desired place. Some of parts are shown below,

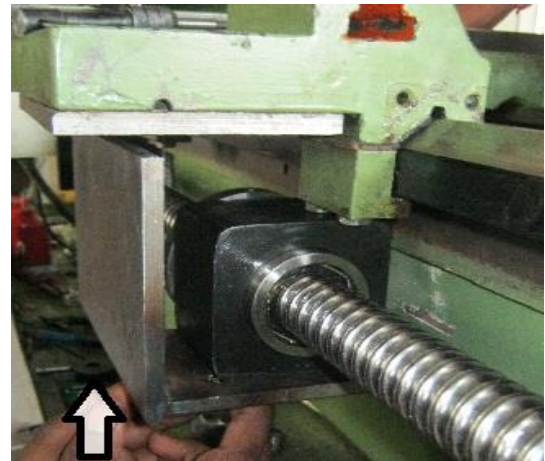

Fig. 7 Z-axis ball screw attached on main slide

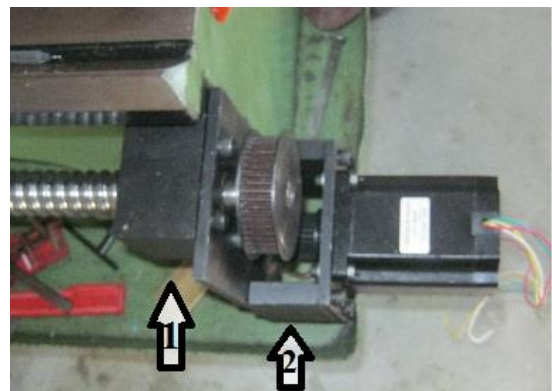

Fig. 8 Z-axis Mounting bracket & Stepper motor



Fig. 9 X-axis mounting & stepper motor



Fig. 10 Proximity switch



Fig. 12 Developed retrofitted lathe machine

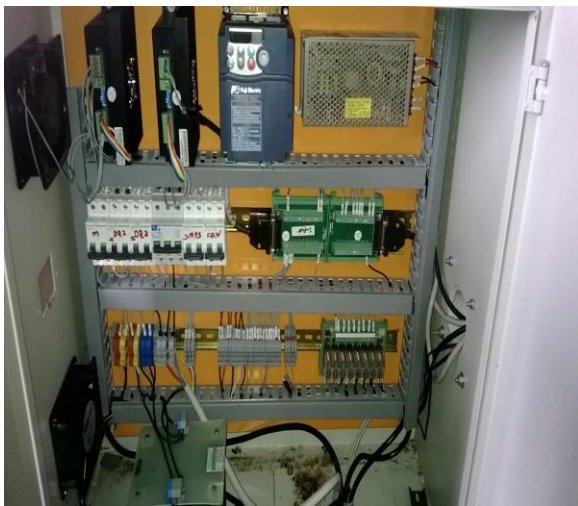

Fig. 11 Control panel

Step 5:- Inspection & testing of new developed Retrofitted Lathe Machine

In this step I have checked all components are properly fitted with machine body and alignment of both ball screws. Also checked both slide working properly by stepper.

Then I have manufactured job on developed retrofitted lathe machine by using turning operation program which is from manual part program method. And checked surface finishing of the job.

IV. COMPARISON

For comparison I have compare job manufactured on conventional lathe machine & job manufactured on developed retrofitted lathe machine.

And I have concluded that surface roughness, production rate, dimension stability, one time set up cost is high in retrofitted lathe machine while machining time, machine slide wear is too much low.

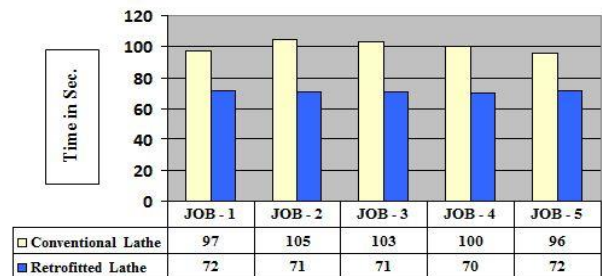

Fig. 13 Comparison of machining time between job manufactured on proposed & existing lathe

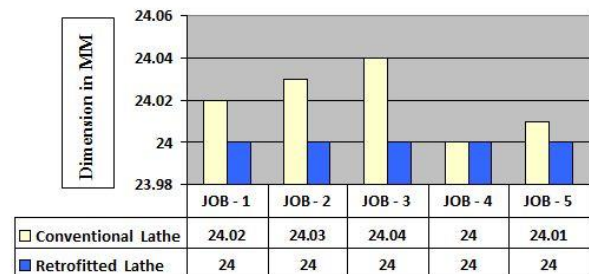

Fig. 14 Comparison of job dimension between proposed & existing lathe machine

Also I have tested three samples (2 samples from retrofitted lathe & 1 sample from conventional lathe) for surface roughness in Tirth Agro P. Ltd.

The job manufactured on both the machine are shown below,



Fig. 15 Job Sample

The certificate of surface roughness is shown below,

SHAKTIMAN TIRTH AGRO TECHNOLOGY PVT LTD INSPECTION REPORT SHAKTIMAN				
Inspection Parameter : Diameter Ovality, Taper & Surface Roughness				
Inspection Method : Digital Micro Meter & Surface Roughness Tester				
Note : All Dimensions are in mm rather than roughness value				
Sample No.	Diameter Taper	Diameter Ovality	Roughness Value (Micron)	Diameter Size
Sample - P	0.04	0.006	1.441	22.91
Sample - R	0.024	0.004	1.106	23.965
Sample - L	0.02	0.01	1.743	23.01

Inspection by : Imran Dela Verify By : Nilesh Joshi

Date : 29.03.2014 Date : 29.03.2014

Comments : For Sample P & R Roughness value and Diameter ovality ok as compare to Sample L. Taper is not set in sample P & R.

Fig. 16 Certificate for surface quality

V. CONCLUSION

By developing automation in conventional lathe machine by retrofitting stepper based method, the machine works as CNC trainer for teaching, learning of the student subject. Also Cost of machine is minimizes approximate 4 times below the original CNC trainer.

As automation new developed retrofitted lathe is done by replacing or removing the components from conventional lathe machine, therefore setup cost is high as compare with standard lathe machine but production rate is too much high. So it is very useful for mass production.

The accuracy of the job manufactured in retrofitted lathe machine is also high so repeatability and dimensional stability of manufactured part is achieved. At last some complex job which is not manufactured in conventional lathe machine can be manufactured in new developed retrofitted lathe machine.

REFERENCES

- [1] Machine Tool Failure Data Analysis for Condition Monitoring Application, Department of Mechanical Engineering, Indian Institute of Technology, New Delhi. K. S. R. L., On-line Machine and Process Diagnostics, Annals of the CIRP. , 32(2), 469-473, 1984.
- [2] V. Roy • S. Kumar from Inst. Eng. India Ser. C(April-June 2013) 94(2):187-195 DOI: 10.1007/s40032-013-0064-2
- [3] Karl-Heinz Schumacher (2013), Multispindle Lathe. US patent # 2013008702/2013
- [4] In 2013, M. Moses & Dr. Denis Ashok M. Tech, Mechatronic from School of Mechanical and Building Science, VIT University, Vellore, India 978-1-4673-6150-7/13/\$31.00 ©2013 IEEE
- [5] We have also used following links,
http://en.wikipedia.org/wiki/Numerical_control
<http://en.wikipedia.org/wiki/Lathe>
<http://www.epa.gov/ozone/title6/609/technicians/retrguid.html>